











Digitized by the Internet Archive  
in 2014

<https://archive.org/details/canadianforest1891donm>





C. C. CLEVELAND. G. F. CLEVELAND.

**J. L. GOODHUE & CO.,**

MANUFACTURERS OF

**Leather Belting**

AND

**Lace Leather.**

DANVILLE - - QUEBEC.

THIS SPACE FOR SALE

RAILROAD, BANK & OFFICE

**DESKS**

TEES & CO.,

300 ST. JAMES STREET, MONTREAL.

**STORAGE OF LUMBER.**

We are prepared to receive any quantity of Lumber for storage. Freight and money will be advanced on same. Also, Warehouse Receipts issued, which can be hypothecated to banks and others. Storage charges easy. For further particulars apply to

**W. LEAK & CO.**

Lumber, Coal and Wood.

DUNDAS STREET, - - TORONTO.

**GOODDAY, BENSON & CO.**

QUEBEC, P. Q.

**General Lumber AND Timber Merchants.**

Correspondence is solicited from parties having choice stocks of Hardwood and Pine to offer, either in the log or in sawn lumber.

**JOHN BERTRAM & SONS,**

CANADA • TOOL • WORKS

DUNDAS, ONTARIO.

MANUFACTURERS OF

**WOOD-WORKING MACHINERY**

MACHINE TOOLS, ETC.

Write for Prices and Catalogues

**Packing Cases in Shooks.**

Any Saw mill in Canada able to undertake large orders for Case Boards is requested to communicate with

**W. & C. PANTIN**

147 Upper Thames Street,

LONDON, - - - - - ENC.

**GEO. CORMACK**

Wholesale and Retail Dealer in

All kinds of LUMBER.

Lumber Shipped to all parts by Rail or Vessel.

WHITBY, - - - - - ONTARIO

**COPPERINE** The Millwrights and Engineers Safeguard.



Engineers' SAFEGUARD.

No Hot Boxes. Stands any weight or motion. Best and cheapest metal known for Machinery Journal Bearings. Reliable Machinists use no other. To be had at every enterprising Hardware store in the Dominion.

ALONZO W. SPOONER, Patentee and Manufacturer, PORT HOPE, ONT

**A. T. ANDERSON & CO.,**

CONTRACTORS FOR

**ELECTRICAL AND GENERAL MACHINERY.**

Complete instalations of Steam and Hydraulic Power, Electric Light and Power Plants, Wiring and Construction for Arc and Incandescent Lighting. Agents for the celebrated "C. & C." Electric Motors.

75 Adelaide Street East,  
Toronto, Ont., Canada.

Estimates furnished and every information cheerfully given to intending purchasers.

N. B.—Only first-class work on which a full guarantee will be given.

**THE RATHBUN COMPANY,**

DESERONTO, - - ONTARIO,

MANUFACTURERS OF

**Doors, Sash, Blinds, Stairs**

AND ALL KINDS OF WOODEN HOUSE FINISHING MATERIALS.

CEDAR OIL FOR PURGING BOILERS.

CORRESPONDENCE SOLICITED

Wood Working Machinery for Sale

- 1 20 H.P. engine, boiler and smoke stack.
- 1 No. 3 planer and matcher.
- 1 No. 1 shaper.
- 1 Scroll saw.
- 1 Rip saw bench,
- 1 Moulding machine to mould 4 sides.
- 1 Iron frame tenoning machine.
- 1 Morticing machine.
- 1 Swing sawing machine.
- 1 Blind slat tenoning machine.
- 1 Double acting hand wiring machine.
- 1 Swing iron sand-papering machine.
- 1 Turning lathe.

And also a large quantity of Belting, Shafting and Pulleys.

The above machinery is almost new.

Apply to

LUMBER

TRUCK \* WHEELS.

**The Montreal \***

**\* Car Wheel Co.**

MANUFACTURERS OF

**THE MONARCH BOILER**

(PATENTED) **AND HERCULES ENGINE.**



Portable from 6 to 70 horse power. Surpass portable steam power heretofore produced for strength, durability, compactness, and the ease with which they can be moved.

The 70 horse power can be taken over the roughest roads, or into the forest, and set up as easily and quickly as an ordinary 20 horse power portable engine, and as firm as a brick-set stationary engine. Engines and boilers of every size and description. Rotary Saw Mills, Shingle and Lath machines, Law Grinders, Planers, etc. Mill machinery and supplies of every description. Every boiler insured against explosion by the Boiler Insurance & Inspection Co. of Canada. Write for circulars.

A. ROBB & SONS, Amherst Foundry and Amherst, N. S. Machine works.

ESTABLISHED OVER 40 YEARS.

**THE BALL ELECTRIC LIGHT CO. LD.**

MANUFACTURERS OF



**ELECTRIC LIGHTING APPARATUS**

57, ADELAIDE ST. W. TORONTO ONT.

**T. SHORTISS,**

DEALER IN

**PINE & MINERAL LANDS**

9 Toronto Street, TORONTO, ONT.

CORRESPONDENCE SOLICITED.

P. WHITE, - - - - - Pembroke, Ont.

**MARK H. IRISH**

Broker and Commission Agent.

Special attention given to buying and selling

Saw Mills, Timber Limits and Mineral Lands

In the United States and Canada.

NO SALE NO COMMISSION.

Room 12 Mail Building, Toronto, Ont.

CORRESPONDENCE SOLICITED.

CHARCOAL IRON CHILLED

**RAILROAD WHEELS**

Offices: New York Life Insurance Building, Montreal.

Works: Lachine, Quebec.

WE make a Specialty of Wheels suitable for the requirements of Lumbermen and Street Car Service, and can supply them B Finished and Balanced.

CORRESPONDENCE SOLICITED

TAPER TOOTH.

**Burns**

**&**

**Thomas**

MANUFACTURERS  
OF

LANCE TOOTH.



TELEPHONE 5120.

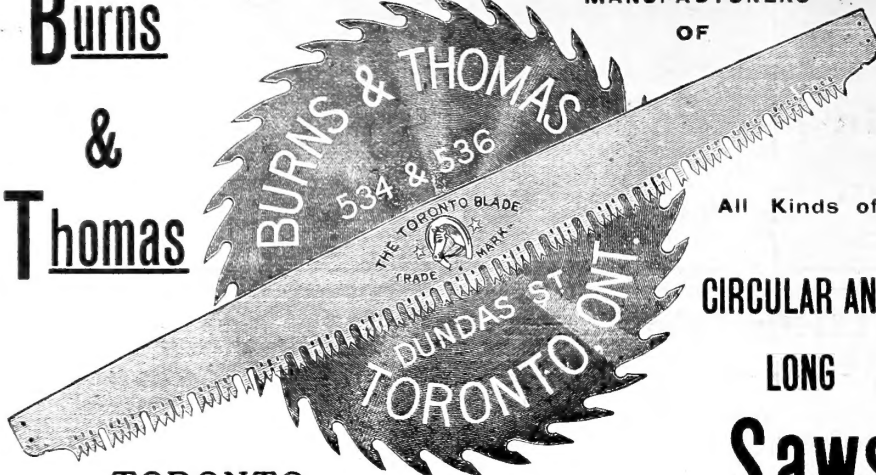

TORONTO.

All Kinds of  
CIRCULAR AND  
LONG  
**Saws**



WORKS AT PARKDALE.

# The Dodge Patent System of ROPE TRANSMISSION OF POWER.

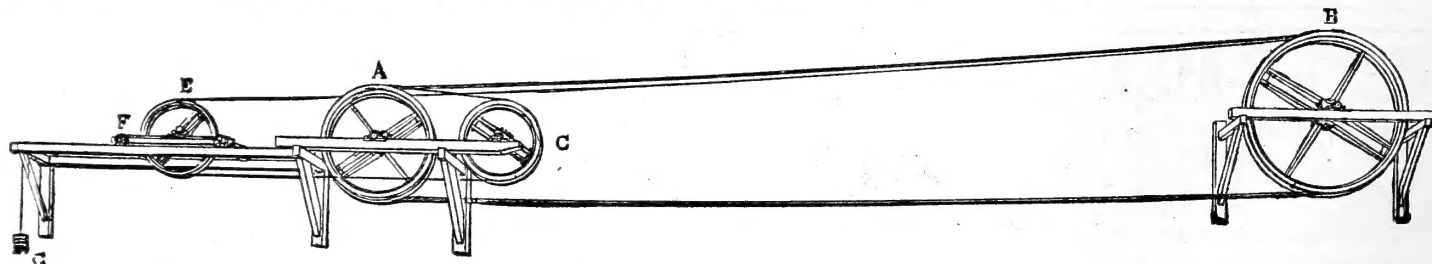

The above cut represents a simple Drive from one shaft to another, and can be applied in any case, or to any distance, in or out of doors. The ordinary space between centres being limited, to say, 100 feet, after which additional Carriers can be added to any distance. For full information and particulars, apply to

## \* Dodge Wood Split Pulley Co. \*

City Office, 83 King St., W.

TORONTO.

TELEPHONE 2080.

## THE "LEADER"

The Finest Tempered, Fastest Cutting and Best Saw made on the Continent.



Manufactured of Triple Refined Silver Steel, Rolled specially for us from Superior Ingots.

THE KING OF CROSS-CUT SAWS.

R. H. SMITH COMPANY, LTD., ST. CATARINES, ONT.  
Sole Manufacturers



**THE CANADA LUMBERMAN**

PUBLISHED MONTHLY BY

**ARTHUR G. MORTIMER,**

OFFICE :

75 CANADA LIFE ASSURANCE BUILDING,  
TORONTO, ONTARIO.

TERMS OF SUBSCRIPTION :

One Copy one Year, in Advance, - - - - - \$1.00  
One Copy six months, in Advance, - - - - - 50

Advertising Rates Furnished on Application.



OUR NEW QUARTERS.

The Offices of THE CANADA LUMBERMAN have been removed to the

CANADA LIFE BUILDING,

King Street, West, Toronto.

TO VISITING LUMBERMEN.

LUMBERMEN visiting Toronto are invited to use the office of the LUMBERMAN as their own. We shall take pleasure in supplying them with every convenience for receiving and answering their correspondence, and hold ourselves at their service in any other way that they may desire.

THE TIMBER TRADE OF QUEBEC.

Messrs J. Bell Forsyth & Co. Review the Timber Trade of the Past Twelve Months.

At the close of another season we beg to lay before you the usual trade returns comprising the supply, export and stock of timber, deals, &c., at this port, together with comparative statements, &c.

The arrivals of ocean steamers show a larger amount of tonnage than last year, while there is a falling off in the list of sailing vessels from sea, and a steady increase in the number of craft coming from the lower provinces. This statement compiled by Mr. F. Johnson shows that 250 vessels, 238,162 tons, cleared at this port laden with timber, deals, &c., against 275 vessels, 240,892 tons in 1889.

At the time of writing our annual circular a year ago, the markets in Great Britain were firm and consumption comparatively large, while many anticipated that the requirements for the coming year would exceed that of the past. In this market the prices of all woods had advanced and contracts were freely entered into with the manufacturers at the enhanced rates for this season's delivery. The high prices then current had the result of stimulating the manufacture especially of white pine, while unfortunately the demand fell far short of what had been reckoned on as the probable shipment. The result has been on the whole a heavier supply than usual, a very moderate export, and a wintering stock considerably over that of late years.

WHITE PINE.—From the opening of the season to the close there has been an utter absence of demand,

and a striking feature and one worth noticing is, that apart from some Ottawa timber delivered on contract, only four rafts changed hands throughout the entire season.

The supply of waney, as well as square, has been excessive; the export light and the stock wintering heavier than it has been since the year 1886. The usual quantity of good and choice timber is included in the supply which has come to market and been laid up in coves without any attempt being made to sell, so dull and depressed has our market been. In the face of such heavy stocks it would be well could we state that no timber was being manufactured this winter, still we learn that the estimated quantity on the Ottawa is unprecedentedly small, while in the Georgian Bay, Michigan and elsewhere it will be exceedingly light. A very large proportion of the timber wintering is held on manufacturers' account. The local requirements have not absorbed as much of the common and inferior wood as usual.

	Supply.	Export.	Stock.
1890 { Square ..	5,082,772	5,498,380	4,799,633
{ Waney ..	3,694,742		3,528,209
1889 { Square ..	4,224,426		3,146,676
{ Waney ..	3,770,782	6,872,960	1,914,001

RED PINE.—The supply has been light, barely half of the previous year, while the stock wintering is above the present average, though far short of some years ago when this wood was in greater request, especially for the Irish markets. The manufacture this year will be almost nil.

	Supply.	Export.	Stock.
1890.....	324,702	355,520	612,918
1889.....	739,435	397,680	653,918

OAK.—The quantity measured shows a slight diminution with a considerable decline in shipments, and a larger wintering stock than in 1889. Prices have been fairly maintained during the season, and closed at firm rates; the impression prevailing that the production this winter will be light. The quantity remaining over at Garden Island is smaller than usual.

	Supply.	Export.	Stock.
1890.....	1,227,982	1,119,160	753,566
1889.....	1,359,660	1,538,080	596,399

E.L.M.—The demand has been sluggish, and while there is a falling off both in supply and shipments, the quantity now in the coves is almost double that of last year. The manufacture has, we believe, almost ceased for the present, the wintering stock being considered ample for next year's requirements.

	Supply.	Export.	Stock.
1890.....	611,582	530,260	459,501
1889.....	750,559	791,800	238,735

ASH—Has been in very limited request, while the stock wintering is extremely light. The figures received from the Customs as to the export are manifestly incorrect as regards both birch and ash.

	Supply.	Export.	Stock.
1890.....	142,450	15,280	99,385
1889.....	250,558	335,360	127,001

BIRCH—Has been dull of sale with a moderate enquiry at times for prime fresh wood. The export figures give a heavier shipment than has actually taken place.

	Supply.	Export.	Stock.
1890.....	224,652	493,740	13,752
1889.....	355,550	479,280	38,784

STAVES.—There is little to report in this branch of our trade, the receipt and shipment of staves having almost ceased at this port. Our quotations are nominal.

	Supply.	Export.	Stock.
1890 { Pipe	11	77	34
{ Punccheon	8	142	21
1889 { Pipe	79	72	41
{ Punccheon	125	116	122

DEALS—PINE.—There is a considerable decrease as will be seen by the statements, in the amount of business usually carried on in pine deals. Not only has the supply and export been small in comparison to years gone by, but the stock now on hand is unusually light. The quantity held over at Ottawa and Montreal is also reported to be less than usual. There has been a fair demand all season for the lower grades, but firsts

and seconds have been difficult to dispose of at current rates. Large shipments have been made as usual from the port of Montreal.

	Supply.	Export.	Stock.
1890.....	878,810	1,075,992	246,015
1889.....	1,389,869	1,307,842	693,197

Do.—SPRUCE—Have been dull and neglected all season, prices have declined, and at the present time it is very difficult to effect sales. We believe the production will be small unless higher figures can be procured in Great Britain, which seems doubtful at present owing to the low prices of North Europe woods.

	Supply.	Export.	Stock.
1890.....	3,839,914	3,975,576	774,020
1889.....	3,684,468	3,584,468	1,159,682

SAWN LUMBER.—Throughout the season the market has been much depressed for shipment to the United Kingdom, but the American market has continued fair, and the demand for Canadian goods is an increasing one.

The South American trade has been very dull indeed, and present prospects are not encouraging.

We quote pine at \$15 to \$18 per thousand feet b. m. and spruce at \$10.50 to \$12, according to quality, size, &c.

Freights opened at 25s. for timber, and 60s. to 62s. 6d. for deals, closed at 16s. for timber and 40s. to 42s. 6d. for deals.

The following are the arrival and tonnage at the port of Quebec for the five years from 1886 to 1890, inclusive.

SAILING VESSELS FROM SEA.					
	1886	1887	1888	1889	1890
Vessels....	432	393	318	392	381
Tons.....	331,568	295,912	260,301	326,706	320,093

OCEAN STEAMSHIPS.					
	1886	1887	1888	1889	1890
Steamships	285	287	244	324	341
Tons.....	528,950	541,324	484,449	596,598	642,874

LOWER PROVINCES.					
	1886	1887	1888	1889	1890
Vessels....	348	425	447	371	442
Tons.....	145,189	193,136	231,518	196,269	241,242

COMPARATIVE STATEMENT of sailing vessels cleared at the port of Quebec, for sea, (Lumber laden) 1877 to 1890, from the opening to the close of navigation.

(Compiled by Mr. F. Johnston, Quebec Exchange.)

Year	Vessels	Tons
1877.	796	670,627
1878.	476	399,833
1879.	433	364,628
1880.	634	555,451
1881.	459	380,186
1882.	426	359,025
1883.	487	416,169
1884.	366	291,398
1885.	369	294,789
1886.	325	250,635
1887.	271	206,172
1888.	227	195,928
1889.	275	240,892
1890.	250	238,162

RULE FOR ESTIMATING STANDING TIMBER.

Following is a rule for estimating standing timber, prepared by George Bonsfield, of London, England:—

"When a tree stands so that a length of its shadow can be measured, its length can be readily ascertained by setting a stick upright, and as the length of the shadow of stick is to its height, so is the length of the shadow of the tree to the height of the tree: or, multiply the length of the shadow of the tree by the height of the stick and divide by the length of the shadow of the stick.

Example—Supposing the height of the stick be 5 feet and its shadow 6 feet, and the length of the shadow of the tree 25 feet, what is the height of the tree?

$$6 : 5 :: 25 : \\ \hline 5 \\ \hline 6125 \\ \hline 20 \text{ ft. } 10 \text{ in. height of tree :}$$

But when there is no shadow to assist you in your calculations it would be advisable, in the absence of a rod or short ladder, to screeve the tree, say at 6 feet, and walking backwards take a full view of the tree and judge the number of 6 feet lengths there are in it.

But after a little practice in this way it will be seen that shadow, rod and ladder can all be dispensed with (except in special cases), and your eye becomes then your sure guide."

### WOODS FOR FURNITURE.

A writer in a New York paper says: "The styles furniture now-a-days change nearly as often as those in women's bonnets or men's scarfs, and like these are continually reverting to modes that found favor in the days of our forefathers. Manufacturers have not yet exhausted their powers of invention as far as finishes are concerned, but they are busy puzzling their heads trying to ascertain what kind of woods will supercede the American white oak now so extensively used in the manufacture of furniture.

Several years ago black walnut was very popular, and an enormous quantity of stock made up from that wood was sold. After walnut came cherry stained black, or "ebonized," as it was then called. Its forbidding appearance ruined it in the minds of buyers, and it did not last long. Then came cherry stained to imitate mahogany, or "mahoganized." This proved a good venture, and is still popular. Oak is finished in every conceivable way. The latest is in imitation of an antique and Louis XVI. designs.

The cost of furniture to-day averages ten per cent. more than a year ago. Oak has advanced from twenty to thirty per cent. owing to its growing scarcity, while the trade is paying from ten to thirty per cent. more for mirrors, tacks, brass and bronze finishes than they did this time last year. Two years ago there was a craze for heavily carved furniture, and it ran to such an extreme that good taste was ignored. To-day the care is expended in finding fine-grained woods. The percentage of very fine furniture manufactured is small. The medium and cheaper grades constitute the greater part of the manufacturer's outfit.

To summarize: The woods used in making furniture are rosewood, mahogany, walnut, cherry, oak, cedar, ash, sycamore, birch, maple, beech, poplar, white-wood and pine. Rosewood is the most valuable, mahogany follows, and the others in the order named. Ebony, satin, tulip and olive woods are also used, but to a very slight extent.

Four qualities are bought by manufacturers. The first grade timber is entirely free from knots. The second contains a few knots. Rejected seconds rank next, and are almost as good as seconds. Culls which contain many knots and checks comprise the lowest grades.

Rosewood is no longer in great demand. It has been used in all styles, and, like mahogany, is always considered in good taste.

Walnut comes principally from the Southern and Western States.

Southern and Western walnut differs from that grown in the East in that it is softer, more easily worked, and warps less. It is much preferable for cabinet use. A small quantity is imported from France and called Circassian walnut. It is dark and smooth-grained. Both the domestic and foreign grades can be handsomely polished. The butts, or roots, which formerly were used in manufacturing gun-stocks only, have of late entered into fine grades of furniture. When finished naturally they show beautiful mottled figures.

Walnut is imitated, but not to a great extent, by white woods—maple, birch, and even poplar. The imitations are easily made. Maple is used in the west for this purpose and is difficult to detect. Cherry finished smooth is also brought into play at times, but the difference in price is so small that it does not pay. Walnut ranges in prices from forty to one hundred and forty dollars per thousand feet.

Two kinds of oak, plain and quarter-sawed, are the woods now demanded by manufacturers. Quarter-sawed oak is made by cutting a log in quarters, and then "slicing" off the boards with the grain. When finished naturally it has a grain and brown mottle of uncommon finish. When used for bureau tops it ranks with marble or agate. The grain is very hard to imitate.

The "antique" oak furniture sold nowadays is an imitation of English Brown oak. It is made from American oak, which is lighter in color. It is stained in order to obtain the dark brown and white mottle of the genuine. "Tinkering with any wood," an expert says, "destroys its beauty." This seems especially true of oak. Bleached oak is the latest thing in fin-

ishes. The plain oak is subjected to a treatment which brings it out white. The oak supply comes from West Virginia, Tennessee, Arkansas, Missouri and Indian Territory.

English brown oak is imported in comparatively small quantities; it is sold at fifty cents per foot. Owing to the large waste in finishing, it becomes nearly as expensive as rosewood. Only the oak trees are valuable. They are cut down just previous to the period of decay, so that the two shades of brown can be obtained. Dealers in valuable woods say that individual trees only are purchased. Cherry is one of the finer domestic woods, lighter in color than mahogany and having less character in the grain. It is used largely for its own good qualities and as an imitation. It can be and is imitated by poplar, birch and maple, but takes a better polish than any of these. New York State supplies considerable cherry to the trade. Pennsylvania also supplies a great deal. The balance comes from the Southwest and West. It is sold in grades ranging from forty dollars to one hundred and twenty dollars per thousand feet.

Cedar is used in making wardrobes, chests, etc. It is knotty, and difficult to obtain clear. A clear log is very seldom found. It comes principally from South America. This country grows considerable cedar, which is not used to any extent. In color it is a light red, which is hard to imitate. Cedar has a peculiar smell not possessed by any other wood. Owing to this bogus cedar can easily be detected. Only about one tenth of the cedar sold by dealers is used in the manufacture of furniture. It is principally made up in cigar boxes and lead pencils. In prices it ranges from ten to thirty cents per foot.

Ash is one of the domestic woods found in large quantities. It can be imitated by painting and grain-ing birch and whitewood; but owing to its cheapness, this is not done by many manufacturers. This applies also to sycamore, birch, maple, beech and poplar.

Ebony, satin, tulip and olive woods are used principally in making small fancy cabinet work. Ebony can be obtained only in small logs. Those which are ten inches in diameter are considered of good size. It comes chiefly from Ceylon and Madagascar. It is notable for its hardness. Importers sell it at eight cents per pound. Satin wood is grown on the Island of San Domingo and in Porto Rico. It is one of the beautiful woods, and is described as a "canary yellow." It is scarce, and is now considered a rare wood. In the log it sells at seventy-five cents a foot.

### SAW MILL EVOLUTION.

[SOUTHERN LUMBERMAN.]

From the primitive hand saw to the modern circular saw was a long step in the path of mechanical progress, and the band saw now coming fast into general use, bids fair to signalize a more important advance still in woodworking industries. Just as coal gas eclipsed the tallow dip of our grandfathers, and the incandescent and arc electric lights in turn eclipsed the gaslight as an illuminant, so does the band saw threaten to consign the service of the circular saw to the limbo of the lost arts. That it is destined ultimately to supercede the circular saw for most purposes of wood manufacture we do not entertain a doubt. The chief obstacle to its perfect success at present seems to be the lack of skilled band sawyers. But it is maintained by the advocates of the band saw process, that the circular saw in its inception encountered a like obstacle and experienced the same ordeal which the band saw is now experiencing. It is a matter of history that at one time many circular saw-mill experiments were practically abandoned by reason of the fact that operators were not sufficiently expert in the management of them.

In the introduction of the band saw it was found that many of the parts were too light, the wheels too small, and the saws too thin and narrow, and when it was attempted to run at the same feed as the circular, the saw ran "snaky," in the sawyer's vernacular, and when strained sufficiently to avoid that they were broken. Experience has demonstrated that the band saw must have sufficient strength to sustain it against the feed required; the saws must be wider and thicker;

the wheels of greater diameter, and the whole machinery heavier. New devices are now being supplied with improved methods for supporting the wheels, improved construction of saw guides and band wheels and a superior system of straining the saw. A Cincinnati machine, much favored, has a cast-iron lower wheel, much heavier than the upper wheel, so that its inertia, together with that of the heavy driving pulley will "carry on" when the saw enters a cut and lead the top wheel even should the lack of sufficient power permit a slight slackening of speed in the cut. With this arrangement it is claimed there can be no trouble from crooks at the commencement of the cut or from dished boards. It is further claimed that these band mills can be made to run so that the travel of the saw will be 10,000 feet per minute, which is from 1,500 to 2,000 feet more than is accomplished by other forms. The output, however, depends not less on improvements in the machinery than upon the training and skill of the operator. A sawyer may be a first-class operator of the circular saw, and yet a very indifferent band saw operator, until he has become an expert by training. Very likely as the band saw comes into more general use, apprentices will be specially trained for their manipulation, just as printers are being trained to operate the new type-setting machines. Doubtless there will be much "snaky" wood turned out, and many saws broken before the band saw process reaches the perfection that will enable it to successfully compete with the circular saw. Band saw mills are being erected in various parts of the South, and a Chicago firm will try one in Mississippi on yellow pine. That success will attend their efforts is devoutly to be wished.

### INSERTED TOOTH SAWS

By J. H. MINER.

The inserted tooth saw is the best saw in its place. The question is, how is the mill man to know this? Many men have failed in the business when if they had had a good inserted tooth saw they would have made money. Then this subject is a matter of interest, that is for mills of small capacity.

I will now explain the advantages of a good inserted tooth saw. Some are not worth buying. If the mill man is sawyer, filer, engineer, yard clerk, etc., the inserted tooth saw is much the best saw. This is with a man who may understand fairly well about gumming and filing. The principal difference comes in the saving of time. If a mill man's time is worth more attending to customers, belts, engines and machinery at odd times than it is to be buying emery wheels and files, losing time filing and gumming, to say nothing of saw growing smaller and requiring hammering, then there is no question about the inserted not being the best saw. In small mills, from four to eight thousand capacity only, I have noticed that the owner or sawyer attended very nearly to all the machinery, looking after the water. On the other hand, if mill is to be run regular and the sawyer knows his business, has an engineer and has time to file his saw and gum it, and does it right, the solid saw may be used, but then there is an inclination to favor a good inserted tooth unless mill goes above fifteen thousand capacity. The great trouble about solid tooth saws is, as I have stated already, they get too many teeth in them. It is a fact that with too many teeth and light power the best man in the world could not run a saw successfully, especially in hard wood. The inserted tooth overcomes this in that the makers do not and cannot put in so many teeth. The inserted tooth requires less hammering, which is an advantage to small mills, and many inserted tooth saws are run one to two years without regumming or hammering.

The same mill with the solid would stand a good chance of not only having saw hammered several times, but would probably have hammered into a new saw. Why? Because a man that cannot file or swage a solid saw soon ruins it. With the inserted there is some retort, viz: Put in a set of sharp teeth; hence a new saw every time. Inserted teeth saws are generally not abused half as much as the solid, and I have had many to ask why, in the same hands, this is plainly seen. With the solid saw running bad, what is done? Cannot stop and file, as saw has just been filed and



swaged. That would not help the case. What is done in many cases? Saw is cooled off with water dashed on it, which only adds to its ruin. The inserted is not treated so. Why? Because the sawyer knows that it will run with sharp teeth, stops and puts them in. The filer might stop and file the solid, but only to make it worse. There are plenty of men running saws who know practically nothing about them. This is not saying anything against them, as it certainly could not be expected that all men could be experts. The inserted tooth for edger saws in large mills is becoming a favorite and gives good results, and maintaining another important item, viz: Attains their size. Inserted teeth saws of reputable makes maintain their tension for a long while because the teeth and rings are milled to a gauge, the rim is not stretched more in one place than another by teeth not exactly the same size. If rivets or keys are used a very light blow gives all an equal strain. Such saws are hammered as the solid, but with less tension, as centrifugal force does not act as much on them.

**TRANS-ATLANTIC LUMBER SHIPMENTS.**

The lumber shipments from Miramichi to the United Kingdom, Continent, Australia, etc., for the season just closed, were as follows:—

Names of shippers.	No. of Vessels.	Tons.	Sup. feet Deals, scantling, boards, etc.	Palings, etc.
J. B. Snowball	47	28,371	23,971,126	2,531,150
W. M. McKay	30	20,877	20,044,505	
D. & J. Ritchie & Co.	22	11,770	11,016,349	87,100
N. B. Trading Co.	19	10,885	9,326,493	
F. Hutchison	15	9,321	8,827,352	139,096
Geo. K. McLeod	13	7,495	6,787,197	
G. Burchall & Sons	10	6,445	6,143,000	13,550
Muirhead & Co.	3	1,851	1,517,264	
	159	97,015	87,638,256	2,771,499

In addition to the above Mr. Snowball shipped 14 tons of birch timber and 33,000 laths to U. K.

Miramichi shipped 22,000,000 s. f. less than last year.

The trans-Atlantic shipments, for the season, from Richibucto, together with those from Buctouche, to July 1st, were as follows:—

Name of Shipper.	No. of Vessels.	Tons.	Sawn Lumber, sup. ft.
J. & T. Jardine	9	5,168	4,731,746
Geo. McLeod	14	4,969	4,090,000
Edwd. Walker	7	2,048	2,120,411
Henry Irving	2	678	570,733
John B. Wright	1	282	312,400
Total.	33	12,736	11,825,287

Under the head of miscellaneous wood goods, Geo. McLeod & Co. shipped 150,000 s. f.; J. & T. Jardine 97,974 and H. Irving 89,797 s. f. hardwood.

Following are the total shipments of wood goods from the port of Bathurst to trans-Atlantic ports during the season of 1890:—

Name of shipper.	No. of Vessels	Register Tonnage	Total sup. ft. Deals, scantling, boards and ends.	Birch Deals sup. ft.
K. F. Burns & Co.	2	966	906,915	
St. L. Lumber Co. (ld.)	16	8,422	7,460,750	198,000
W. M. McKay	2	1,679	1,646,498	
Total	20	10,767	10,014,163	198,000

Bathurst shipped fifty per cent. less lumber to trans-Atlantic ports this year than last.

The trans-Atlantic lumber shipments of Dalhousie, for the season of 1890, were as follows:—

Shippers	No. of Vessels.	Tonnage	Sawn lumber sup. ft.
Geo. Moffatt & Co.	14	6,604	5,724,000
Geo. K. McLeod	5	3,744	3,297,720
Goolday, Benson & Co.	2	2,360	1,849,854
King Bros.	3	1,540	1,426,958
N. McNair	4	1,114	1,115,951
G. Dutch & S. Laughlin	2	619	593,000
Dutch, Laughlin & McNair	1	466	263,000
Henry O'Leary	1	439	383,000
Total.	32	16,832	14,633,488

Geo. Moffatt & Co. shipped also 540, and N. McNair 48 tons timber.

The shipments of Campbellton were:—

Shippers	No. of Vessels.	Tonnage	Sawn lumber sup. ft.
W. M. McKay	7	4,869	4,263,454
W. M. McKay & H. O'Leary	1	380	367,000
Henry O'Leary	2	1,190	1,149,684
L. D. Sowerby	3	1,491	1,387,802
J. P. Mowat	1	556	312,842
Total	14	8,486	7,481,782

The North Shore shipments may be put, in round numbers, at 132,000,000 s. f. for 1890, against 162,000,000 last year, a falling off of 30,000,000 s. f.

St. John's shipments up to 1st December this year

were 132,608,516 s. f. against 80,167,488 s. f. for the corresponding period last year—a falling off this year of 47,558,972 s. f.

**THE RELATION OF BANKS TO BUSINESS INTERESTS.**

[NORTHWESTERN LUMBERMAN.]

Business methods are continually changing: on the part of banks it has been towards unification, and has resulted in concentration of power, which, if not used wisely, can break business men at will, or, if that sensitive thing called capital takes fright, can smash things generally. The time of greatest need on the part of general business interests is at that critical period when banks become conservative and call in more or less of their money. Business interests have been drifting in a direction which naturally, under present banking conditions places them at the mercy of banks. In the manufacturing and mercantile line at least 75 per cent. of the volume of business is represented by time paper, making necessary large discount lines at banks. The more extensive the business the larger the discount line required. The fact that a business house transacts business at any particular bank becomes well known to other local banks, so that any attempt at enlarging discount lines by opening an account at another local bank is almost certain to be looked upon with suspicion, and in most cases will result in starting a line of investigation which will find weakness, if any exists.

If an attempt be made to open an account at a bank in a town other than that in which the business man may have extensive local interests—visible assets—the applicant will be met with a polite refusal.

It has been demonstrated time and again that quantity of assets and size of surplus, in excess of liabilities, will not prevent failure when the bank closes or unreasonably shortens the discount line, such action by the bank being certain just at the time of the greatest need on the part of the borrower. In fact, a bank can break almost any extensive business interest, and if it becomes alarmed, whether justly so or not, and it can get first security, a crash is sure to follow: and when it comes, assets, which, with time, manipulated in conformity to the general policy of those who originated and controlled the business, would pay every cent of liability and leave a competency, but by reason of changed conditions, shrinks 25, 50 or a still larger per cent. In hopes to "pull through," or tide over a present difficulty, a chattel mortgage or other preference is given in most cases. This is the beginning of complications which quickly make an end of the business.

On general principles, preferences of any kind are wrong, and the making of such places power in the hands of the holder or holders, which sooner or later proves to be uncontrollable by the giver. The preferred interests will take no chances.

When a crisis arises in the affairs of a business house, the wise course is to keep all creditors on the same basis, then a satisfactory compromise and extension is possible. If fewer bank preferences were given there would be fewer failures.

**THE IMPORT DUTY ON CEDAR.**

[NORTHWESTERN LUMBERMAN.]

After March 1, 1891, as provided by the new tariff bill, cedar paving, posts, railroad ties and poles imported from Canada will become subject to a duty of 20 per cent. ad valorem. A great deal of complaint has been heard in the past, from Minnesota and Michigan especially, regarding the disadvantages at which producers of cedar in some portions of those states were placed on account of the facilities enjoyed by Canadians for marketing cedar in the United States, and a memorial from farmers who were injuriously affected in that way was sent to congress, asking that a duty be placed upon cedar. This request was heeded, although complaints were heard on the other side of the question.

Certain Michigan operators have claimed that the lack of a tariff on cedar was not what ailed the market, but that the large Chicago concerns that controlled the cedar business were responsible for the poor returns to those engaged in getting the wood out. One operator in particular, who publishes a paper at Rogers

City, Mich., gave the Chicago cedar men a severe roasting some time ago. His paper went on to say that the Chicago cedar syndicate had killed the goose that laid the golden egg; that the influx of Canadian cedar had not choked off home production, but that it had been done by the infamous inspection meted out at Chicago to home shippers, and the refusal to give home inspection; that there was a large amount of cedar timber still standing in Michigan; that the industry, once the largest in the world, Michigan and Wisconsin, had died an unnatural death, and that operators had said that the cedar might not where it stood, or Canada supply the demand, or else Chicago handlers gave home inspection, fair prices and a square deal.

It is well enough known that a few large operators have controlled the cedar business, and that competition has not been of such a nature as to prevent them from making good profits. Inspection, however, is rigid largely because the railroad-paving men and others insist on it, and the contractor must also have it. That the cedar business of northern Michigan and Wisconsin is really dead is emphatically denied, while the practicability of allowing home inspection is not admitted. Michigan and Wisconsin railroads have taken a great deal of cedar at remunerative prices, outside of the agency of the contractors of this city.

A great deal can, of course, be said on both sides of the question, but, so far as cedar imports are concerned, there are many operators who have not suffered from Chicago inspection, but who have been knocked out by Canadian cedar. A Toronto exchange reports that hundreds of car loads of telegraph poles are shipped yearly from different points in Ontario, principally from Dundalk, Romney, Buckhorn and Kingsville to Buffalo, Pittsburg, Syracuse, Cleveland and other points in the United States, while the tie trade of Romney, Buckhorn and Kingsville keeps many Canadian vessels constantly employed. The McKinley Bill, it was thought, would entail a great financial loss upon those who are engaged in shipping this class of products, many contractors having entered into engagements for a year at stated prices, but the date on which the duty should go into effect was postponed in order to help such contractors out to a reasonable extent.

**A FIGHT FOR LIFE.**

The Ottawa *Free Press* publishes a sensational account of an encounter between four shantymen, who belong to Ottawa, and a pack of ravenous wolves in the woods in the vicinity of Gordon creek, on the Kippewa river. John and James Barrett, Peter Murphy and John McManus are working in a shanty near Bois Frane depot on the limits of Messrs. Booth and Gordon. All four had quit work in the evening and started to return to their camp. The Barrett brothers, who were ahead, verged a little from the brush road in order to examine a trap which they had set in the woods to catch marten. Their two companions went on ahead, but had not proceeded more than ten minutes when they heard loud shouting mingled with the barking of wolves. They hurried back along the path and soon discovered the cause of this terrible uproar. A short distance off the road at the foot of a big pine tree the Barretts were standing, their backs to the tree, desperately defending themselves their axes against 15 of the ravenous animals. Murphy and McManus ran to the rescue, and not a minute too soon, for one large animal had torn the trousers off James Barrett and inflicted a wound on his leg with its sharp teeth. The four men then laid about them and were appalled to see that the pack of wolves was growing larger, being reinforced by a number of equally desperate animals. After fully ten minutes of this fighting for their lives, seven of the wolves had been killed, which had an effect upon their companions, for they turned tail and fled. All the men were bleeding from the legs and side, where they had been bitten, and when they met foreman Charles O'Neil and his men a short time afterwards their blanched faces showed plainly what they had undergone. No doubt remained in the camp that if the Barretts had been left to fight it out alone they would have lost their lives. All four men are well known and have relatives living in Lower Town.

## EDITORIAL NOTES.

STATEMENTS prepared by Government Statistician Johnson go to show that while Canada only sent \$1,100,000 worth of lumber and other products of the forest last year to the West Indies and South Central America the United States sent \$7,000,000. There is a big market for lumber to the south of us, outside of the United States, and to that market it would be well if our lumbermen would direct their attention as well as to the West Indies.

CANADA has fifty-six paper and pulp mills now in operation, employing 2,250 hands. The manufacture of pulp is fast becoming a special industry, and it is probable that before long wood pulp will form a special item of export. The best wood fibre is made from spruce and poplar, of which the country produces unlimited quantities, particularly in Quebec and New Brunswick, and the conditions for manufacture in those provinces are very favorable.

SINCE the Dominion log export duty matter has been disposed of, says the *Northwestern Lumberman*, American lumbermen feel better and Canadian lumbermen, excepting the spruce men, are highly encouraged. To have the differences between the two countries settled has been a beneficial result all around, and there is no danger that either country will suffer by the arrangement. While the matter was pending imagined evils appeared worse than the actual trouble itself. It is to be hoped that both governments will take pains to prevent future difficulty from a like cause.

REGARDING the good points of cypress, an architect says: "It has more nearly the qualities of white pine than any other wood and yet it is firmer and stronger; it shrinks less, it warps less, and it expands less. It holds paint better than pine. It partakes of the highest polish. It finishes beautifully in oil. It is easily worked. It is as cheap as pine. It has no pitch and hence is less inflammable than pine. It makes the best tanks, vats, etc. It is insect proof. It is the most durable wood in the world."

THE total exports from Canada for the year ending June 30th, 1890, amounted to \$96,749,149, of which \$27,289,264, or twenty-nine per cent. of the whole were products of the forest. As regards the exports of lumber, etc., an increase of \$2,820,008 is shown as compared with the corresponding period of 1889. Next to lumber the exports under the heading of animals and their products stand first on the list, amounting to \$26,630,672 in value. In the previous year the exports under this heading exceeded lumber shipments. Of the products of the mine, the value exported amounted to \$5,126,131; the fisheries \$8,524,508; agricultural products \$17,245,575; manufactures \$6,388,064; miscellaneous articles \$183,081.

At the present time a project is under contemplation which is the revival of an old scheme, for the completion of a water route for large vessels between Chicago and Europe by the construction of a ship canal between the Georgian Bay and Lake Ontario, and the deepening of the St. Lawrence channels above Montreal. Only sixty odd miles of canal are needed to unite the waters of the Georgian Bay with those of Lake Ontario, and competent engineers pronounce the scheme perfectly feasible. It is entirely within the bounds of possibility, and it is very probable that the next decade may witness the completion of such a canal or ship railway to serve a similar purpose, and in that event, who shall put a limit on the commercial benefit to be derived from it.

CHANCELLOR BOYD recently delivered judgment in this city in the suit of Thompson vs. Hurdman & Co., of Ottawa. In this case Messrs. Thompson sued Messrs. Hurdman for \$123,000, a balance claimed from them to plaintiffs on the purchase of the water power on the Chaudiere, both where their mills stand and the

table rock power. This property Messrs. Thompson sold under a charter granted Christopher Wright by the province of Lower Canada, 3rd January, 1806. As a defence Messrs. Hurdman claimed that the power was not included in the grant or charter, but was the property of the Quebec government, from whom it was leased by their Mr. W. G. Hurdman. Chancellor Boyd, in his judgment, holds that the original charter includes all the power, and gives judgment in full for the plaintiff.

The importance of the lumber trade of the Dominion may be estimated from the fact that in no other branch of her export trade did the figures reach those representing the value of lumber and forest products exported to other countries.

A MAN at Apple River, N. S., has contracted to pick 600 lbs of spruce gum this winter, to be delivered packed in six pound boxes at Parrsboro.—*Exchange*. What a gratification it is to know that Canada can at least realize something from its spruce forests. It now devolves upon the U. S. government to pass an act prohibiting the removal of gum from spruce logs taken into that country.

JOSEPH B. ABBOTT, chief salesman and confidential clerk of the lumber firm of H. W. Sage & Co., of Albany, N. Y., committed suicide in that city on the 3rd ult. Mr. Abbott was practically manager of the concern, and although drawing a salary of \$5,000 per annum, he turns out to be a defaulter of from \$80,000 to \$100,000. Extravagant living and gambling are said to be the cause of his defalcation.

THE exploring expedition, appointed by the United States government, which went to the northern boundary of Minnesota to look into alleged timber depredations by Canadians, returned lately and reported that the thieving, if any, was of less consequence than had been supposed. The result happens to be just what was predicted by THE LUMBERMAN some months ago.

MAJOR HIGH is the name of the personage who has charge of sending out special agents to catch thieves on United States government timber lands, and he is said to be very reticent about the far-famed Rainy Lake expedition sent out a short time ago to catch alleged timber thieves, and bring back from over the border the thousands of feet of stolen timber. Four special agents were detailed for this purpose, and since their return *rum* has been the word, and so far neither the timber nor the thieves have been forthcoming. A Washington correspondent of the *Mississippi Valley Lumberman* undertakes to throw some little light on the affair. He says "they had a row among themselves, over some question of authority or management of the expedition, and when the expedition completed its summer outing they no longer spoke as they passed by one another. Whatever they did with their unusually large outfit of tin kettles and other picnic paraphernalia, I don't know, and there is no trace of them in the accounts of the department. They may be heard from later. But the four special agents in charge are yet to be heard from. They were not on sufficiently good terms to unite on a report, so each one went in for himself. Four reports were made out, and all will in good time come to Major High. It is hinted that when the agents come to headquarters to settle up finally, there will be four different kinds of music in the air."

THE bill respecting the protection of public interests in rivers, streams and creeks, introduced by Hon. Mr. Duhamel, is of considerable importance to lumbermen and those whose lands are traversed by lumbering streams. This act does not apply to the St. Lawrence, nor the Ottawa rivers, nor to rivers or streams in which salmon, trout, ouananiche, touladi, black bass or perch do not abound. Neither does it apply to dams, weirs or bridges on such rivers. Nothing in the act shall affect the right of joint stock companies for the transmission of timber down rivers and streams. The ob-

ject of the measure is to allow any person, firm or company, during spring, summer and autumn freshets, to float and transmit timber, rafts and crafts down all rivers, streams and creeks in the Province, subject to regulations set forth in the act. These regulations provide for the payment of tolls for the using of improvements made on these waterways by private persons, the protection of such works from injury, the manner of collection of tolls and prosecutions for injuries. The act also provides a system of fines and penalties for dumping refuse of mills and other obstructions into rivers and streams. It is similar in its provisions to the Ontario Act on the same subject, and will obviate disputes and difficulties regarding the rights of lumbermen such as gave rise to the famous lawsuit between the Dominion and the Province of Ontario concerning jurisdiction over rivers and streams.

WHILE the great staple of Newfoundland is her fisheries, there is growing evidence that at no distant day the colony is bound to become a timber centre, if not a strong competitor for trade in the English market. There are now 55 mills at work in the great Bay of Notre Dame, or Green Bay, where there is some excellent forest timber, consisting principally of birch, pine, spruce and fir, or as it is called in Canada, balsam. The pine board obtained is closer grained and much wider than what is generally obtained from the neighboring colonies. It is estimated that in Green Bay there are 720 square miles of pine and spruce timber, which if manufactured into lumber, would be worth millions of dollars. Newfoundland is rich in minerals as well as timber, and as capital is seeking investment in that direction, there is no doubt that in the near future these resources will be developed to a considerable extent, as they are in close proximity to desirable markets.

TWO movements of great moment are being pushed by Philadelphia business men. One is that of rapid transit, the other the establishment of a "Bourse," or a place for the transaction of general business. The idea was suggested to Mr. Bartol while on a visit to the continent of Europe. On his return home the matter impressed him to such a degree that he called together representatives of nearly all the commercial exchanges in the Board of Trade rooms, where the matter was thoroughly discussed and a committee appointed to investigate. The proposition is to secure from the city a plot of ground known as "Washington Square," located in the heart of the city, at 7th and Walnut Sts., and now used as a public park containing a number of acres. Here it is proposed to build a general exchange building, where business men will congregate, where buyer and seller can barter, and the two great classes, the purchaser and the purchasee, can transact as much business in an hour as they ordinarily could in an entire day. Here it is proposed to put up apartments for sample rooms and the various offices and departments incident to a work of this character. The committee is hard at work on preliminary arrangements. The plan is growing in favor. The idea of concentration is strongly urged by Mr. Bartol, who goes on to say: "Every person who desires to be considered a man of business, either of Hamburg or any of the adjacent towns, must not only be a member of the exchange, but must be represented there daily. Prior to the opening hour members may be seen arriving from all quarters and passing at once into the surrounding corridors, where the statistical information of the world is before them. In a few moments all can acquaint themselves with those matters which are of interest to them in their own fields of operation, so that on the striking of the gong all are ready to assemble on the large central floor for business. There are no calls of the different articles handled that I was able to learn of. All meet for actual business and trade directly with each other, with the result that the volume of business transacted in the limited space of time mentioned is marvellous. It will readily be seen that an immense business can be done under the circumstances, when all parties necessary to a transaction are within touch of each other."

THE reduction in the export duty on lumber has occasioned a considerable stir in lumber shipments from the Parry Sound district to the United States. Large stocks had accumulated in the different mill yards in anticipation of the change in the tariff, and it is safe to surmise that the holders have not lost anything by refusing to sell until the new tariff came into force.

A CHARTER of incorporation has been granted by the Ontario Government to Messrs. Cant, Galt, Ont., under the title of "The Cant Bros. Co., of Galt, Limited." The company will continue the manufacture of wood-working machinery, which has received two gold medals at the Toronto and London exhibitions, and also iron tools. The amount of capital stock is \$40,000.

A CORRESPONDENT writing from Portland, Me., says that it would be well for some of the Canadian mill men to turn their attention more to local trade. Many of them, he says, saw too many boards, while if their logs were cut into dimension lumber they would get a better price, as many shippers from Canada do not grade their boards well enough to pass inspection on the Boston or other American markets.

ONE of our Barrie subscribers, on renewing his subscription to THE LUMBERMAN for 1891, voices his sentiments in the following complimentary style: "I take pleasure in congratulating you upon having reached the position which enables you to secure one of the most beautiful, convenient and best business situations in Toronto. You may not be aware of it, but I have watched the progress of THE LUMBERMAN from the little acorn to the tall oak." Thanks.

WITH this issue of THE LUMBERMAN we again enclose statements of subscription accounts, many of which are long past due, while others are for the current year. In balancing our books for the year we find—and the fact is much to be regretted—that upwards of \$2,000 is outstanding on our subscription books. We very much dislike "dunning" our readers for these small amounts, but the aggregate is so large that we have no other recourse but to urge payment. If all who find a statement enclosed in their paper would pay off the old score, and forward an additional dollar for the year 1891 the editor would be made happy and subscribers generally would benefit in proportion.

MAJOR-GENERAL STRANGE's article in the *United Service Magazine* on the Canadian Pacific Railway is of an eminently practical character. He is not content, as so many travellers have been, to expatiate on the beauties of Canadian scenery or confine himself to grandiloquent predictions. He tells us what the goods are which are lying in Canada and in Australasia awaiting a steam service to effect their exchange. "I saw on the wharves of Tasmania," he writes, "pine lumber from Norway and the Baltic shores. Fourteen thousand miles across two oceans it had been carried, while at about one-third the distance the gigantic pines of British Columbia wave in millions waiting to be felled; while the magnificent hard woods of Australasia would find a ready market in Western Canada, where literally for 1,300 miles no hardwood grows from which you could cut an axe-handle." As for the present illogical constitution of the British Empire, General Strange can hardly restrain his contempt for "the mischievous and wasteful pranks of the Lords of Misrule in the British Disunited States." Here is one instance: he was refused a money order from Tasmania to his son in Canada "because the only arrangements for postal communications between Australasia and Canada were through the United States Post Office."

THE *Miramichi Advance*, in a recent issue, takes the *London Timber Trades Journal* to task for statements concerning the St. John harbor and the effect the severe cold has upon shipments from that port. The *New Brunswick Journal* says that St. John is never for

a moment, at any time of the year, closed by ice, and navigation is never stopped. The reason why St. John deals do not go forward in winter, as in summer, is because it does not pay, save in exceptional cases, to either saw or handle spruce for shipment there in winter. Very few of the spruce-cutting mills are operated in winter, because they are located on the river above the Falls and open port of St. John, and their booms, by reason of the ice, can neither be supplied with logs nor kept open, so that they can be handled. The output of these mills can be shipped during the summer and few of them winter any appreciable portion of their cut. Some of the smaller mills on the railway lines running to St. John take advantage of low freight rates in winter to send their deals to St. John for shipment; but, as a rule, it does not pay to ship spruce deals anywhere in New Brunswick in winter, and no possible displacement of sailing tonnage by steam can materially increase the transatlantic winter wood trade of St. John or any other port of this province. If prices in the transatlantic markets were considerably better than they are, we might load quite a fleet of steamers at that port with Miramichi and other North Shore deals, but there do not seem to be any other conditions under which the spruce trade of St. John can be maintained during the winter months at anything approaching its summer volume.

#### SPLINTERS.

THE LUMBERMAN has again the pleasure of wishing its many readers a happy and prosperous New Year.

LEWIS D. SANBORNE, of the lumber firm of Brown & Sanborne, has disappeared from Saginaw, Mich. It is said that he is involved to the extent of \$50,000.

A TRUST has been formed by all the leading lumber concerns of Georgia to control the world's supply of long leaf-pine. It is said to be an immense concern, involving millions of dollars.

THE second annual convention of the Northwestern Lumbermen's Association will be held at Minneapolis, Minn., beginning Wednesday, Jan. 28th, 1891, and continuing three days.

"THE box shoo and spruce men of Canada are as blue as a streak of sap. Things seem to be a little against them.—*N. W. Lumberman*. Yes, the big American hog has been snorting around again and picking up feed.

It is claimed that American lumbermen have made more money the last season than for some three or four years past. The recent heavy failures in the lumber line have not been taken as an evidence that the lumber trade is not prosperous.

THE recent snowfall throughout the country has proved very beneficial to the lumber trade so far. Logging operations are progressing favorably, and from present indications the cut of logs will be successfully hauled to water.

THE Marine Department has just published two charts based on Commander Boulton's hydrographical survey in the Georgian Bay last year. One chart covers St. Joseph's Channel, the other that portion of Byng Inlet from Collins' Inlet to McCoy Island.

AT a meeting of the local Board of Works, held December 16th, the following tenders were accepted: W. Leak & Co., lumber, gang sawn, two inches thick, \$12.57 per 1,000 feet, board measure; scantling for sleepers, \$12.57 per 1,000 feet. A. W. Godson, cedar paving posts, per cord \$5.95; cedar plank, as per specification, \$13 per 1,000.

A Lumberman found a bottle containing \$1,000 in gold dust near Sly Park, El Dorado County, Cal. He could not imagine what the saw could be striking in the middle of a tree three feet thick. After the tree was cut down and an examination made, a bottle containing \$1,000 in gold dust was found in the centre of the tree. It was probably put there by some old miner.

WE beg to draw attention to the advertisement in another column of J. Bell Forsyth & Co., Quebec, who are offering 300 miles of virgin pine limits to the public. This block, though apparently lower down on the Ottawa, is bordering on the territory lately explored by the Quebec Government. The pine is said to be of choice quality and large growth.

#### NEW BRUNSWICK MATTERS.

From Our Own Contributor.

The notice given in the last issue of THE LUMBERMAN regarding the remarks of a Baltimore correspondent, on the subject of the recent change in the tariff on lumber, has been carefully noted. The correspondent referred to says: "I am surprised at the quiet position of the lumber press regarding the change in the tariff heretofore existing between the United States and Canada. We may as well acknowledge that we have been out-generated, or that in diplomacy that the Canadians are our superiors," etc., etc. No doubt the Dominion Government will swallow such flattery without seasoning; but those who know the facts, and understand the consequences, will say the lumber press has only been showing its good sense in keeping comparatively silent on this subject. It is only those who can see the true inwardness of the situation that can realize how our government has been duped by removing the export duty on all our lumber in consideration of the paltry reduction of \$1 import duty on Canadian pine. The correspondent above referred to evidently well understands the importance of any country protecting its manufacturing interests. He says: "If crown lands could be bought with no restrictions as to where the logs should be manufactured into lumber, Americans could then continue to furnish employment for American laborers at home." All of which goes to show that this particular writer is looking after selfish interests without regard to the claims of others on his consideration. He would take possession of the virgin wealth of our forests and allow our native labor to lie dormant, and permit those who depend upon the work in our forests for sustenance to starve or steal. So far as the Dominion Government is concerned, its recent legislation on the import duty question is calculated solely to encourage the removal of our spruce and other woods for manufacture in American mills, thus encouraging foreign capital, labor and consumption instead of our own. Such legislation requires no comment, but should be looked upon with disgust and contempt by all patriotic men.

If the Dominion Government would devote more attention to subsidizing manufacturers of our woods into articles of practical utility for export to all nations, instead of giving all to railways, it would hold twenty of our citizens where the railways will not hold one. Railway navvies and others are naturally shiftless, while mechanics are permanent, and materially assist in building up a prosperous community.

At the time this letter is being written we are having by far the most severe storm of the season. It is blowing a gale and the roads are fast being blocked for traffic. The depth of snow is beginning to threaten a great drawback in lumbering operations. Ever should the season prove favorable for work in the woods, we may count on a falling off of about fifty per cent. on the production of previous seasons.

The employees of Miller & Woodman, mill owners, at St. John, have gone out on strike. Their mill is situated at Milford, on the west side of the river. It employs nearly 150 men and boys. The strike is in the shingle mill. The cause of the men's refusal to go to work is a ten per cent. reduction which was made in their wages. The owners say they will shut down the mill until the men return to work.

The lumber shipments from the northern portion of New Brunswick during the season show a falling off as compared with 1889. The present year the shipments amounted to 132,000,000 superficial feet as against 162,000,000 feet the previous year—a falling off of 30,000,000 feet. Baie Verte sent in round numbers 11,000,900 superficial feet to the United Kingdom, and Parrsboro' 32,566,186 feet.



## THE NEWS.

### ONTARIO.

—Messrs. Vigars Bros. have opened a lumber office at Fort William.

—Owen Brothers have started a shingle mill on the Lee farm, not far from Warminster.

—The Waubaushene box factory is running full time and doing all the work it is capable of doing.

—Mr. N. A. Beach, of Georgeville, proposes building a saw mill at Magog in the spring.

—A future city of importance is predicted on the Rainy River at Fort Francis, where there is a fine water power.

—It is reported that there is not likely to be much lumbering done in the Penetanguishene district during the present winter.

—Bronson & Weston are operating on their limits on the Rockliffe river, and Perley & Pattee are operating on the Black River.

—Taylor & Lount, saw millers, of Whitevale, Ont., have failed. The mill, it is said, has been a losing concern since its inception.

—The Victoria Harbor Lumber Co are placing a planing machine in one of their mills which, together with the shingle machine, is to run during the winter.

—A. Lumsden's saw mill, at Gordon Creek, has shut down for the season. He has a small gang getting out logs for next summer's cut, but does not intend taking out any for sale.

—Mr. Daniel Baker has completed arrangements for building another saw mill at Uthhoff. This will make four mills at Uthhoff, and all intend stocking to their full capacity this winter.

—A boom of logs brought to Midland by Mr. Nickerson from Victoria Harbor broke loose near Peters & Cain's mill and half went adrift. Men had to go out with a tug to save the balance.

—The snow is reported by lumbermen fully two feet deep in the line adjacent to South Bolton. If the weather is propitious there will be more logs drawn to the river in the vicinity of South Bolton than for several years past.

—Owing to the scarcity of work around the Chaudiere, Messrs. Bronson & Weston have opened up a couple of shanties on the Schyan river, principally for the benefit of their mill hands whom they have employed during the summer.

—W. C. Edwards & Co. are carrying on lumbering operations on the Gatineau quite extensively this winter. They have six camps of men at work and are about to start another shanty. The pine on that river is, however, becoming rapidly exhausted.

—A new branch of the Knights of Labor has been formed in Ottawa. It already numbers 56 men, and they expect to largely increase that number, and are contriving to extend the movement so as to include the men in the shanties on the Upper Ottawa.

—Messrs. McClymont & Co. have sent no men into the woods this winter, and will close down for next summer. Mr. McClymont says there has been so much stocking done this year it is only destroying the woods without there being sufficient remuneration and the stock remains unsold.

—The weather has been splendid for timber operations around Sturgeon Bay, and log cutting has been going on in good style. Shields' men having finished cutting near the mill, have moved up into their winter quarters to finish cutting next summer's stock of logs.

—The cedar mill at Deseronto, after a splendid run, closed down on Dec. 31st, for several weeks in order to make the annual repairs which will be more extensive than usual this year. After these repairs are effected this establishment will probably run all winter.

—Messrs. Boyle & McCracken, of Ottawa, have sent a sufficient number of men to the woods to take out three rafts of square pine timber and one of cedar on the Desert and Gatineau. They say that heavy frost has been favorable to lumber operations, as the swamps are now completely frozen over.

—The youngest son of the late David Moore, of Ottawa, having recently attained his majority, the lumbering business carried on by the deceased, and later by his eldest son as trustee, will now be wound up. The estate consists of valuable timber limits and real estate, and is estimated to be worth half a million dollars.

—Mr. Alex. Carswell, of Renfrew, a well-known lumberman in the Upper Ottawa, says that the present season is one

of the dullest he can recollect in the trade. On the Madawaska he has as many men at work as he had last winter, but other firms have decreased their operations by one-half and some are not doing anything. On the Petewawa, where Carswell, Thistle & McKay had three shanties last winter, they have only one this year, with about one-third of the number of men employed.

—Mr. Alexander Lalonde, owner of a saw mill in the 10th concession of Roxborough, county Grey, committed suicide December 6th by hanging himself in the upper story of his house. Deceased was an honest, upright man, who had been greatly depressed by financial reverses, and it is thought his troubles had affected his reason.

—Lumbermen's wages started out very low at the beginning of the season, but have slightly advanced during the past month. In the Ottawa district choppers get from \$18 to \$22, teamsters from \$15 to \$17, and road makers from \$13 to \$15. Little square timber will be gotten out, owing to a dull market and large stocks on hand.

—The big mill at Deseronto commenced cutting on April 7th, and has made a magnificent record during the season. The mill closed down on December 1st, and had the weather allowed it to cut for a few days longer this great establishment would have completed a long season of eight months.

—Reports from the Black River district state that this fall has been a most favorable one for bush work. Mr. Booth has two shanties in operation at his Couvreau depot, and the other lumber firms have about the same number as during the past two winters.

—Douglas C. Cameron, Walter Ross, Hugh Wm. Kennedy, Matthew Brown and Richard Hall, lumbermen of the town of Kat Portage, are applying for incorporation as the Rat Portage Improvement Company, for power to acquire, construct, maintain and operate slides, dams, booms and other improvements to render possible and to facilitate the passage of timber and logs down the Whitefish and other rivers.

—J. G. Bryson, of Fort Coulonge, has recently purchased the Grand Lac limits, on the Ottawa, owned by P. Fitzpatrick, of Allumette island. These limits were sold to Mr. Fitzpatrick at the provincial sale at Quebec, January 9th last, the price then paid being \$58,600. It is not stated what the Messrs. Bryson now pay but it is a substantial increase on the above figures.

—Mr. J. R. Booth has torn down his old mill on the Chaudiere, and now has about 76 men at work taking out the machinery. The erection of the new mill will be commenced as soon as the ground is cleared, and it will be fitted with the latest improved machinery throughout. The new machinery is being manufactured by Messrs. E. L. Perkins & Son, of Ottawa, and will keep a number of men busy day and night during a large part of the winter. The whole cost of the alterations is estimated to be in the neighborhood of \$250,000.

—Mr. Hebron Harris states that this season he has rushed ties into the United States, and now is busy shipping by rail all that he can get cars for so as to have as many in as possible when the duty comes in force on March 1st. He is also rushing supplies of ties for the C. P. Ry. He states this winter he has one hundred jobbers, employing in all some two thousand men in the bush in the Ottawa district getting out ties and hop poles largely for the States.

—Gradually the lumber traffic through this port, says an Owen Sound paper, has been working up, notwithstanding that during the early part of the season the traffic was practically barred, owing to lack of room, and in fact the shipments did not really begin to arrive until August. But during the entire season there were 36 vessel loads received, bringing in their cargoes about 5,200,000 feet for through shipment—3,000,000 feet of which is now in the C.P.R. yard. We learn from Mr. William Foster, who has handled all of this lumber, that if there had been room at least 7,000,000 feet more could have been handled. Now, however, that the C.P.R. have expressed their determination to have the lumber traffic, we can have little fear but that provision will be made for all that can come this way, even if they have to construct another slip to the north of their present lumber yards. In addition to the lumber received for through shipment, fully 2,000,000 feet have been received for Messrs. Maitland, Rixon & Co., John Harrison and H. Lymburner; 2,000,000 lath also came to this port, half of which was for through shipment. Then there arrived 16 vessel loads of paving timber, making in all 70,000 pieces, the greater part of which was sawn here and shipped through to Toronto. The value of such traffic to Owen Sound must necessarily be very great, because of the number of men employed, and the consequent amount of money put in circulation. In addition to this, the supplies to these vessels and their crews is an important item, while four of the vessels in the trade have made

this port their winter quarters, and their fitting out in the spring will be worth something to the town. Yet, when the C.P.R. consider that their traffic through this port in lumber is so little known that the management ask the co-operation of the Town Council and the Board of Trade in inducing dealers to ship via this port, it is but reasonable to conclude that we are on the eve of something gigantic, and as our harbor leads everything on the lake, so will our traffic in every department.

### NEW BRUNSWICK.

—James D. Leary, the raft man, has been at Ottawa seeking Government aid for a proposed wharf and elevator on his property on the west side of St. John harbor.

—Mr. D. F. George recently brought down 2,000,000 lath from Gibson, opposite Fredericton, to St. John in scows, a vessel not being obtainable.

—Deals for the English market that are sawed at Fredericton and on the Nashwoak, which joins the main river at Gibson, are taken to St. John in woodboat schooners.

—The Victoria mills, at Fredericton, have closed for the winter. During the season about 7,000,000 feet of lumber were cut for the English and United States markets, principally the latter.

—The north shore lumber exports for this season amount to 132,000,000 feet, a falling off of 30,000,000 feet as compared with last year. St. John's shipments are 180,000,000 feet, a decline of 47,000,000.

—During the season just ended 10,014,103 superficial feet of deals, etc., were sent forward to transatlantic ports from Bathurst, N.B. This total does not include 198,000 feet of birch deals shipped by the St. Lawrence Lumber Company.

—F. Moore & Son, of Woodstock, have about completed a new mill to take the place of the one destroyed by fire last summer. The mill is two storeys, and for the present three shingle mills will be in operation, to be increased to five in a short time.

—Of recent years several operators from York county have gone up into Quebec province and cut logs. One of these, John Kilburn, of Fredericton, left with a second gang this week. They go to St. Vallier by rail and then drive about 40 miles. He has, all told, 100 men and 20 horses.

—The woodboat men are now considerably excited over a rumor that Alex. Gibson, the great Nashwoak operator, proposes to build large lighters to carry his deals to St. John hereafter, the lighters to be towed both to and from the place of loading. Gibson's cut goes almost wholly to the British market.

—The lumber cut in Westmoreland county is considerably less this year than that of last year, and operators have been receiving 20 per cent. less for their lumber. The outlook does not indicate improvement for 1891.

—It is stated that lumbermen's supplies around the Bay of Fundy are 20 to 30 per cent. higher this year than last. Oats, for instance, that could be bought last year for 37 cents, cost 47 to 48 cents this year, owing to the failure in that crop throughout New Brunswick.

—C. M. & J. J. Bostwick have purchased the real estate which belonged to the late William Davidson, of St. John, paying therefor the sum of one hundred thousand dollars cash. The property consists of timber lands and two mills on Big Salmon River, St. John county, and other lands and mills at Martin's Head, with three buildings and lots in the city, and some small properties in other parts of the province.

—At the inquiry touching the explosion of the boilers of the South Bay mill, Mr. Jewett, a former owner, testified that the boilers had not been tested for seven years or more, and that the engineers did not have certificates. Public attention has now been directed to these facts, and an agitation is quietly going on for a Dominion act compelling periodical inspection and competent engineers in all saw mills.

—The Maine Labor Commissioner's next report will contain an article showing, among other things, that the total amount of logs rafted into the St. John river from Maine streams and cut by mills in New Brunswick the past year has been 106,080,994 feet. The mills are those situated at St. John, and which are controlled by Americans. The article gives some particulars regarding the amount stated. From Aroostook there came 31,430,331 feet, consisting of 1,753,990 feet of cedar, 1,596,973 pine and 28,079,368 spruce; from Meduxnekeag river, through Woodstock, 13,487,649 feet, consisting of 1,157,673 cedar, 33,830 pine, 12,067,285 spruce and 222,861 hemlock, while Three Brooks, Bridgewater and other places contributed 2,169,014 feet of spruce, and from the headwaters of the St. John river itself, about 59,000,000 feet pine, spruce and cedar. Other tributary streams contributed the balance.



—The large trade done in New Brunswick birch has almost entirely fallen off.

—An item of correspondence from Shenstone, a small village in Albert county in this province, shows to what an extent small mills are operated in some localities where there are not facilities for extensive operations. It says that within a radius of three miles there are two steam mills and eight water-power mills. In the aggregate the cut of all of them makes a respectable showing.

—Notice is given that application will be made for the incorporation of the Lawton Saw Company. The object for which its incorporation is sought is the manufacture and sale of saws of all kinds. The chief place of business will be at St. John, N.B. The capital stock will be \$20,000, divided into 1,000 shares of \$20 each. The names of the applicants are William Henry Thorne, Arthur T. Thorne, T. Carleton Lee, J. Frederick Lawton and Thomas Bell.

—Clarke Bros., at Bear river, N.S., just across the Bay of Fundy from St. John (Bear river emptying into Annapolis basin), will have about 100 men in the woods this winter, and operations there will be quite extensive. Large shipments of lumber are now being made from there to the West Indies. Clarke Bros. last year shipped to foreign ports upwards of 4,000,000 feet of lumber, besides four or five cargoes of pulp wood and a lot of logs and piling.

—There are at present 11,000 men in the lumber woods of New Brunswick. These men spend about six months of the year far removed from settlements and the ministrations of clergymen, and almost entirely without Christian literature. The British American Book and Tract Society has granted \$500 for the purpose of supplying these men with Christian literature. Two men have been employed by the society to visit the various camps and distribute a Bible or Testament, hymn books, a few story books, devotional books, illustrated papers and tracts.

#### NOVA SCOTIA.

—E. Gibson & Sons, who ran a planing mill at Halifax, have assigned.

—Gold River Lumber Co., Gold river, registered partnership: Alex. Chisholm, A. H. Zwicker, James Ernst and C. W. Anderson.

—One hundred and fifty cargoes of grind-stones, piling, etc., were shipped from the Joggins this season, and 32,000,000 superficial feet of deals were exported from Parrsboro' in 41 vessels of 36,000 tons.

#### QUEBEC.

—The Quebec *Telegraph*, a paper noted for its sensational statements, says that the timber trade of that city is on the eve of a crisis, and that some of the banks are loaded to the chimney pots with lumbermen's paper.

—*Hull Despatch*: "Hon. Mr. Duhamel, the Quebec Commissioner of Crown Lands, had a conference with the Bushrangers of this district yesterday. Doubtless the Government are putting up another job on the lumbermen. They must have money, you know, at Quebec.

—The lumber shipments from the port of Montreal to the United Kingdom in the past season were 160,650,426 feet board measure, and from Pierreville 10,427,863 feet, a total of 171,078,289 feet. From Montreal to the River Platte, 3,862,699 feet were shipped, and from Lower St. Lawrence to the same destination 3,798,000 feet, making a grand total of 178,738,983 feet.

—The following amounts of timber from the United States were rafted from July 1st to December 1st, this year, by the Calvin Company, Garden Island, for Quebec: Oak, 13,060 pieces; white wood, 263 pieces; longitudinals, 1,045,478 feet; pipe staves, 12,822 pieces; ash, 11 pieces; poplar, 4 pieces; walnut, 53 pieces; e'm, 320 pieces; West-Indian staves, 19,030 pieces.

#### MANITOBA AND NORTH-WEST.

—Mr. W. H. Atkinson has bought out W. J. Mathers' lumber yard at Deloraine.

—Losee & Morrison, saw-mill proprietors, Shawnigan, contemplate admitting a partner.

#### BRITISH COLUMBIA.

—E. Buse, of Vancouver, has made arrangements with A. H. Van Eiten, lumber dealer, Winnipeg, to handle as his agent all kinds of British Columbia lumber, especially cedar, manufactured at the Buse mill.

—The German steamer *Remus*, which recently sailed from Nanaimo, had on board the largest cargo of timber that ever left British Columbia by steamer for Australia. The cargo was loaded at Moodyville, and consisted of 1,600,000 feet of timber. The *Remus* is the first steam vessel to take a cargo of British Columbia timber or coal to the colonies.

—An unusual activity is reported in all the logging camps around Vancouver this fall. None of the camps have closed down for the winter yet, and possibly they will continue operations all winter. The season is undoubtedly the busiest Vancouver has ever seen.

—The Royal City Planing Mills, and the Brunette Saw Mills, at New Westminster, are now engaged in getting out 5,000 ties each for the Westminster Southern Railway. The railway company has been unable to get its ties down from up the river, where it has many thousands.

—Mr. James Corcoran, a well-known capitalist of Stratford, Ont., who has recently been visiting British Columbia, has decided to build a saw mill in close proximity to New Westminster. He has made arrangements for the acquisition of large timber limits, and he will return to Westminster in the spring to begin operations.

—A new electric plant has just been put in the Brunette Saw Mills at New Westminster. The yard will be illuminated with four large arc lamps, and in the interior of the several buildings some 236 incandescent lights have been fixed. The plant is operated by a 36-horse power engine which has been put in specially for the purpose.

—The Westminster *Columbian* of recent date says: "A large scowload of choice hard timber arrived round from Howe Sound this morning, consigned to Messrs. Wintemute Bros., of this city. The timber consists of maple, birch, ash and other hard woods, and among the maple there is some which is extraordinary in its way. This consists of a number of planks of bird's-eye maple, many of the planks measuring as much as 24 inches across, and from 20 to 28 feet long. This timber is beautifully marked and will make up into magnificent furniture and interior decorations. The fact of bird's-eye maple growing in this country will no doubt surprise many who imagine that this species of the genus *acer* is indigenous to Eastern Canada. Some experts who have seen the timber say it is quite equal to the best they have seen in the East."

#### AMERICAN.

—Hemlock has advanced fifty cents per thousand in Buffalo and Tonawanda.

—Minneapolis saw mills beat the record in 1890 by sawing 344,574,362 feet of long lumber.

—There are only 20,000,000 feet of lumber on the Muskegon docks this year, as against six times that amount the corresponding time last year.

—A trust has been formed by the leading lumber firms of Georgia to control the world's supply of long leaf pine. Millions of dollars are involved.

—The Boston *Herald* is responsible for the statement that preparations are being made for lumbering this winter in Maine upon a more extensive scale than heretofore.

—The lumber cut in Minnesota will exceed that of last year by several million feet. The estimates placed it at 325,000,000 feet and not more than 350,000,000 feet.

—There are thirty lumber dealers in Tonawanda, N.Y., twenty of them having lumber yards. All have nice offices and some exceedingly handsome places of business.

—Of the \$400,000,000 worth of pine now standing in the forests of Georgia, \$160,000,000 worth has already been killed by the turpentine farmers, most of it within the last ten years.

—A mill containing two gangs and a rotary with an annual capacity of 30,000,000 feet is to be built at Trenton Falls, N.Y. The lumber supply for this mill will come from the Adirondacks' country.

—Night sawing has been rather more general this year among the Wisconsin and Minnesota saw mills than heretofore, and the demand for labor has consequently been greater than it usually is.

—The Detroit Lumber Company expects to bank 34,000,000 feet of logs this winter. This firm shipped 41,000,000 feet of lumber the past season. Out of that amount 29,500,000 feet was sawed this year.

—The report of the collector of the port of Tonawanda shows that 313,569,621 feet of lumber, 13,186,000 shingles and 1,258,604 cubic feet of timber were shipped by the canal at that point. This is an increase of 23,366,229 feet over what was shipped last year.

—A discovery has recently been made of a grove of giant redwood trees in Pierce county, Wash., similar in character to those of the Yosemite National Park in California. Some of the trees are said to be 400 feet high and 13 feet in diameter. The people of Tacoma are agitating the subject of having a flag pole made of one of the tallest trees and sending it to Chicago as one of the contributions of the State of Washington to the World's Exposition.

It is estimated that 7,765,000 poles are required to carry the telegraph lines in the United States. This figure does not include the poles used for telephone, electric light, fire alarm and district messenger lines, etc. The poles used are chiefly cedar.

—One Buffalo firm, at least, benefited by the tariff law. They bought a load of pine intending to pay the old tariff rate and it came in under the new tariff, which saved them \$350. Now the Canadian dealers have put up their price which leaves it the same as before.

—Wages in the woods in the American north-west continue to be reported higher than have ruled for several seasons. In the Menominee district and around Green Bay lumbermen are paying \$26 where formerly they paid \$16 and \$18, and \$30 and \$35 where they paid \$26.

—The lumber storage shed is a feature of New England. In the West a specially enterprising lumberman may put his dry as well as dressed lumber under roof, but down East about all of a stock is so protected. The sheds at Boston, Portland and other cities would make a Southerner or Westerner open his eyes. Think of a shed holding 6,000,000 feet of lumber! And yet a Portland exporter has such an affair standing on his dock, and is merely somewhat complacent in its possession and not at all elated.

—The business of transporting Canadian logs to American points having become of great importance since the removal of the Dominion log export duty, the Michigan Log Towing Company has been incorporated, with a capital stock of \$75,000, by Emery Bros., of Bay City, R. A. Loveland, R. E. Loveland, R. H. Roys and D. L. White, jr., of Saginaw, Nelson Holland, of Buffalo, and others, to tow logs from Georgian Bay to Michigan mills. The company now owns two steamers. The affairs of the Loveland Transportation Company, Saginaw, will be wound up.

#### CASUALTIES.

Clarence Wright, a boy employed in a lumber camp at Newburg, was instantly killed by a falling tree some days ago.

Two shantymen named Thomas Mulligan and Jos. Leroux, working in a shanty on the Madawaska, were recently crushed by a falling tree. Both of whom sustained internal injuries.

Murdoch McLeod, whose home was in the township of Kinloss, Bruce county, Ont., had his leg broken in the Michigan lumber woods a short time ago, from which he lost his life. He was brought home for burial.

S. Ott, a workman in the employ of A. Harris, Son & Co., of Brantford, Ont., while tending a circular saw, had his right hand drawn in and two fingers taken off.

Edward Doonan, of Tyendinago, Ont., while chopping in the woods, was struck by a falling branch and so injured that he died.

William Patterson, employed at the stove mill, at Essex Centre, Ont., got his arm caught between a belt and the pulley which drives one of the saws, and was drawn upon the saw. But for the timely pulling of his head to one side by one of the men, it would have been severed from his body. As it was the saw shaved off part of the skull, and his left arm was badly smashed.

Andrew Daly, working in the woods on J. R. Booth's limits north of Ottawa, fell on his axe and inflicted such a wound on his left leg that when he attempted to get back to the shanty the bone snapped. He had to make a journey of 150 miles in a sleigh to the nearest station on the Canadian Pacific Railway before he could get the assistance of a surgeon.

Louis Leblanc, of Hull, Que., a mill hand in the employ of Mr. J. R. Booth, was killed by a dynamite explosion in the mill on December 13th. A big hole, several feet round, was blown clean through the six-inch floor of the new flume, and the dynamite house and contents were scattered in all directions. Leblanc was in the dynamite house at the time of the explosion.

AN exchange thinks that when shingles are honestly and intelligently branded and counted, when flooring is manufactured everywhere according to a uniform gauge, when retail dealers make as good grades as they buy, and when the mill men of different regions cease asserting that the wood they saw is superior to any other, then a lumber millennium may be regarded at hand.

## HOME AND FOREIGN TRADE REVIEW.

Office of CANADA LUMBERMAN,  
Jan. 1st, 1891.

The holiday season has come and gone since the last issue of THE LUMBERMAN, and, as is usual at that period of the year, trade in lumber, as in everything else, becomes practically *nil*.

Local trade may be said to be at a stand-still, and the depression during the holidays is perhaps felt even more keenly this year than heretofore on account of the preceding sluggishness of trade. Most of the lumber-consuming establishments have been holding back their orders, in order to reduce their stocks and facilitate stock-taking, in which they are now busily engaged. The prospects cannot be said to be any too bright, though many of the dealers are looking forward to a fairly brisk spring trade when the factories begin to stock up, and it is to be hoped that their expectations may be fully realized. The Grand Trunk Railway, on the urgent requests of the lumber trade, and with a view to meet special adverse conditions of the trade, has reduced its charges on lumber to the United States, and also increased the allowance on the local trade from 2,000 to 3,000 pounds for shipment on flat cars during the winter season. The dealers have been notified that unless advantage is taken of these concessions, it will be impossible to obtain a renewal of them in future winters.

Trade in the West has not suffered to the same extent from the holidays as the Toronto trade, yet there has been a noticeable falling off of shipments, and it will take some little time before it will recover its usual activity.

Shipments of hard woods to the United States have gradually fallen off, until at present only an occasional car is being moved. This is due principally to the exhaustion of dry stocks. Mill men are making the best of the scanty sleighing, however, in getting their logs to the mills, and there will soon be a fair showing of new stock if no serious change in the weather occurs, and we feel safe in predicting a good opening for hard woods in the early spring, as enquiries are abundant. In this connection we would suggest to mill men that they would do well to pay special attention to the manufacture of basswood and maple. By sawing their logs while the frost is in them they obtain a class of lumber that is always in demand, and at better prices than the ordinary stock will bring.

Cars can be readily obtained at present for all local shipments, and foreign cars are fairly plentiful. There is very little lumber in Toronto yards at present.

There is a better feeling existing among lumbermen in the Ottawa district than for some time past, and most of the mill owners express the belief that the present season will make up for the dullness of 1890, and that business will be brisk in the spring. The feeling seems general that a brighter opening of trade may be looked for with the United States. As regards the English trade it is generally conceded that it cannot be any worse than it was during the year just closed, and there are chances that it may be better, stocks having run pretty low. With respect to the South American trade, though matters are more settled, it is generally admitted that the present high value of gold will prevent an early revival, as lumbermen will not accept so depreciated a currency and will not give credit on it.

The operators in spruce, both in Quebec and New Brunswick, are strongly protesting against the removal of the export duty on logs of all descriptions to meet the requirements of the McKinley bill. They contend that they are placed at a disadvantage as they cannot now pay \$2 duty on spruce and ship to the United States, while pine goes in at \$1 duty. The McKinley bill has made matters worse for the operators in the lower provinces by laying a duty of 20 per cent. *ad valorem* on cedar railroad ties and telegraph poles, which goes into effect March 1st next. Last year Quebec sent to the States ties to the value of \$78,000, while the shipments from New Brunswick footed up to \$77,000.

Across the lines reports go to show that the lumber trade is in a very satisfactory condition. Despite the continued stringency in the money market, the move-

ment of lumber during the month of December has held up stronger than during the same month in any corresponding year. The month will round out a year during which the consumption of lumber has been phenomenally large from start to finish. The prospects are exceedingly bright for the opening up of a good spring trade. As the figures are made up they go to show that at no point is there an excess of stock. It is generally thought that should trade in the spring start with vigor, there is no reason why prices should not advance to some extent. Prices for southern lumber have advanced sharply, and it is believed that unless the money stringency shall upset present calculations, that a further advance will not only be possible, but quite probable.

At Tonawanda the full reports are not in for the season's business, so no estimate can be made with any accuracy as to the season's trade. The canal business has probably fallen off some. It has however, gone away ahead in lumber and timber. Shingles have fallen off. Lumber shipments show 23,369,229 feet over last year. The shipments this year for boards and scantling were 313,569,621 feet, shingles 13,186,000, timber 1,258,604 cubic feet, and 425 cords of wood.

Albany dealers are now in their winter quarters taking inventory of stock on hand. From all indications there is a good assortment of all grades excepting 1¼ inch and 1x12 inch, and thick uppers, which are a scarce article in the market now. The bulk of the shipments was disposed of before the closing of navigation, and the dealers are now prepared to fill orders for car shipment.

Taking it as a whole, the lumber trade at Boston can look back upon a generally favorable season. There has been a very good demand nearly all the time for all desirable stock, and prices are well maintained. The season has been characterized as one remarkably free from financial troubles of all kinds, in spite of the disturbed state, for some time past, of the stock and money markets of the world. The spring season promises to open well; supplies are not excessive, and the prospects are for a good distribution throughout the coming year.

In New York, at this season of the year, trade is very quiet. In the main, assortments are in good shape. There is room for considerable first quality spruce and hemlock.

There is a great scarcity of good lumber in Buffalo. The supply from Michigan is diminishing more and more every year, and stocks must soon come from elsewhere. Reports from the Pennsylvania lumber district indicate a sharp competition for all good timber lands, many of which have lately changed hands. With these things in their minds, lumbermen are looking more than ever toward Canadian forests as a solution of the present problem.

The trade at other American lumber points in which Canada is particularly interested show signs of considerable activity for this season of the year, and the prospects seem good for a heavy demand for Canadian stocks on opening of navigation.

The *Timber Trades Journal*, speaking of the timber trade throughout Britain, says: "Everyone is complaining of bad trade, but is looking forward to better things next year (they could hardly be worse), but we do not think there will be any immediate advance in prices of anything until people see how business goes, and that will not be till well into the new year. The large stocks of pine and spruce will ensure plenty of those descriptions being represented in the public sales of next year, as there are so many inferior parcels in the docks which it will not pay to hold, but the really dry stuff we anticipate will make fair value. The year now passing away must have been most unsatisfactory to the generality of the trade, as very few can have made anything out of it, and when merchants come to take stock at the present low values, as every one must, to be fair in his balance sheet, we expect they will all pull long faces at the result. However, it is no use looking at the black side; let us hope, with the examples afforded in the past, that the trade will adopt a system which will keep them on the right side in the future, and that the losses of 1890 will be more than counterbalanced by the profits of 1891."

## CORRESPONDENCE.

Editor Canada Lumberman:

DEAR SIR,—Would you kindly give me your opinion, or the opinion of any authority, on the following questions:—

Do you think it practicable for a planing mill in this locality (Huron county), manufacturing sash and doors, to expect a profitable trade with Toronto in these goods? In the three locations for a factory which would you recommend. (1st) In Muskoka, where pine could be bought at first cost, but would be subject to higher freight charges in the manufactured goods (sash and doors) to Toronto; (2nd) Huron county, where the pine shipped in the rough from Muskoka would consequently have a less sum to pay on the manufactured articles to Toronto, because of a closer proximity; (3rd) Toronto, where the pine would come in the rough straight from Muskoka, and no excessive freight charges or extra haulage would need to be paid for?

The Huron county location has the advantage of cheap labor, and chances of a good local trade being done, where higher prices are feasible and living cheaper, perhaps.

The expensiveness of operating in Toronto, where wages, rents, etc., are high, must militate against Toronto sash and door men.

Now, the above statements may betray an ignorance of the true relative positions, and a want of "grasp" of the subject in charge, but as you will have an idea of what I am driving at, it would be a great favor to me if you were to give me any authoritative opinion on the matter.

There is one more question, and it is in the lines of one very prominent before the people of Canada today, namely: Granted that we had reciprocity with the United States, would our chances for selling sash and doors not be equally as good in Buffalo as in Toronto? Any information or light thrown on any of the above matters will be thankfully received by me.

THOS. GIBSON, JR.

Wroxeter, Dec. 10th, 1890. (of Gibson Bros.)

[The manufacture of sash and doors, and in fact all varieties of builders' material, has, for several years, been considerably overdone. Especially is this the case in the city of Toronto, where but few, if any, of the numerous factories can find sufficient orders to keep them running at a reasonable capacity the year round. The best location for a factory of this kind is undoubtedly where a local trade can be secured, and where a respectable price for the product can be obtained. Our correspondent mentions Muskoka, in connection with Toronto and Huron county, as a likely point for the establishment of a factory. Taking it for granted that the raw material could there be purchased at first cost, there are two very important reasons why Muskoka would not prove a desirable location. The first of these is the lack of proper shipping facilities, and, second, the prejudice which undoubtedly exists among consumers in favor of goods manufactured in large centers of trade. Then again, the man who understands how to buy can purchase lumber in Toronto almost as cheap as at the point of manufacture. There would certainly not be the difference of the cost of freight. The choice, therefore, rests between Toronto and Huron county, and after a careful survey of the situation we would advise that, if our correspondent already has a reasonably good local trade, that he had better stay where he is; and with the advantage of an already established trade, lower cost of production and reasonable shipping facilities, start out with the object of pushing his goods into outside markets. If the quality of manufacture is up to the mark, there is no reason why goods manufactured at Brussels and other points in western Ontario should not find a market in Toronto and other important centres. Price and quality will tell every time. Referring to the question of reciprocity with the United States, while we do not favor such a measure on general principles, there can be no doubt but that it would open out a very profitable market for those engaged in the manufacture of builders' material.—Ed.]

THE largest bridge now in the North-West is that spanning the Souris river at Milford. Its length is 3,300 feet and it contains one Howe truss of 105 feet. The quantity of material used is 1,300,000 feet board measure. This immense structure was erected in five weeks.

**PUBLICATIONS.**

The subscription price of that well-edited journal, *The Canadian Manufacturer*, has been reduced from \$2 to \$1 a year. THE LUMBERMAN extends its best wishes for its continued success.

We are in receipt of the Christmas number of *The Youth's Companion*, an illustrated weekly paper of eight pages. It is printed on good paper, gotten up in fine style, and contains much that is pleasing and instructive to young people in general. It is issued from the office of *The Youth's Companion*, 41 Temple Place, Boston, Mass. Price, \$1.75 a year.

The revised 1891 edition of the New York *Lumber Trade Journal's* "Directory and Inspection of Eastern Lumber Centers" has been presented to the readers of that journal. In extending to the publishers our thanks for the sample forwarded to this office, we can pronounce it a valuable guide to all who are interested in the eastern lumber markets.

The entire good will and subscription list of *The Mechanical and Milling News* having recently been sold to Mr. A. G. Mortimer, the name is being changed to *The Canadian Miller*, the first number of which is announced to appear on the 15th inst. There can be no doubt but that the change will prove desirable in every way, as the millers and grain trade will now have a journal devoted exclusively to their own interests. The subscription price remains at one dollar a year, and the office of publication is in connection with that of THE LUMBERMAN.

*The Canadian Electrical News* is the title of a new publication, the first issue of which is announced to appear the first of the new year. The rapid advancement of electrical science, and the different uses to which it is being put in this country, has undoubtedly opened a broad field of usefulness for a journal of the character referred to. Steam engineering will also be embodied in the new publication. Mr. C. H. Mortimer, 14 King Street, west, is the publisher, and we wish him every success in his new venture.

The most beautiful frontispiece ever produced in an American magazine, appears in the January number of the COSMOPOLITAN. It is a reproduction in colors of Francois Flameng's famous picture "The Cake Seller," and can scarcely be distinguished from the imported photogravure which is exhibited in the dealers windows, at the price of \$7 a copy. It is one of the most charming of subjects, and is well worth framing and preservation. The COSMOPOLITAN has become noted of late for its frontispieces and this very much excels its previous efforts. The COSMOPOLITAN ran up from a 16,000 edition at the close of 1888, to 100,000 copies December 1890. This remarkable increase has kept pace with the change in the character of the names which appeared upon its table of contents. Among those for January are Mrs. Van Rensselaer Cruger, Frank Dempster Sherman, Henry George, William H. Rideing, Hjalmar Hjorth Boyeson, Edward Everett Hale, Gertrude Franklin Atherton, Murat Halstead, John J. a'Becket, Col. Charles W. Larned, F. O. C. Darley (posthumous), Elizabeth Bisland, probably as strong a collection of names as ever appeared in any number of an illustrated magazine in the U. S. The number contains the 1st of two parts of Mrs. Van Rensselaer Cruger's new novel, *Mademoiselle Reseda*, pronounced by critics who have read it the best of her work. Mrs. Cruger is a woman who is intimately acquainted with fashionable circles both in this country and abroad. She writes in a realistic manner, without any of the offensiveness of the average realism. The next article in importance is from the pen of Miss Bisland, describing a visit to the People's Palace in London. A most interesting posthumous paper by F. O. C. Darley, with his own illustrations, is also given. a'Becket's clever story, *Don Gracias*, is illustrated in a novel manner, the well-known actors, Sothern and Miss Harned, having consented to pose for the situations of the novel, the result being reproduced in photogravure.

**Trade Notes**

A. W. Spooner, of Port Hope, Ont., made a large shipment of his celebrated "Copperine" to Messrs. Goldie & McCulloch, of Galt, a few days ago. This habbitt metal remains as popular as ever in public favor, and hot boxes are difficult to find where it is in use.

Attention is directed to the advertisement in another column of the Cant Bros. Co. (Ltd.), of Galt. The firm

of Cant Bros. & Co., manufacturers of wood-working machinery, has been long and favorably known throughout Canada, and now that new life is being infused into the business, and the work of incorporating the company has been successfully carried out, we have no doubt but that the business will be largely augmented.

In the last issue of THE LUMBERMAN appeared an extended sketch of Petrie's new machinery depot, which is situated near the Union Station in this city. The present issue contains a full page display by Mr. Petrie, and our readers will find it to their interest to watch the page from month to month, and secure some of the bargains in machinery offered.

Messrs. Robin & Sadler, manufacturers of leather belting, Montreal and Toronto, are also manufacturing a belt dressing, regarding which they say: "Having long felt the necessity of supplying our customers with a proper belt dressing, we have studied the matter from time to time, and with our knowledge and experience in the manufacture of belt leather, have succeeded in preparing a grease that we can confidently offer to users of leather belting. The majority of belt oils in the market cause a belt to become sticky and spongy by penetrating and destroying the fibre of the leather, while most of the belt grease for sale is of a sticky resinous nature, that gums upon the surface of the belt, and is very injurious. Our dressing is free from all these objections, for, while making the belt pliable and smooth on the surface, so as to come into close contact with the pulley, it will not saturate or gum the leather, and as a very small quantity is required to produce good results, it will be found twenty-five per cent. cheaper than any other preparation. Especially do we recommend this dressing for use on all belts that are run at a high rate of speed—such as electric dynamo belts, etc." This dressing is put up in cans holding from five to fifty pounds each. Messrs. Robin & Sadler are also offering to belt users Snow's Soft Steel Belt Fastener, which they say is the acme of perfection, and the safest fastener which can be applied for fastening a belt. The excellent quality of soft steel used in its manufacture will readily be recognized by mechanics as far superior to most other fastenings now in use.

**HOW TO TEST BELTING.**

A London journal says to test the quality of belting, a sure method is to take a piece, say 8x2 inches, and cut it down four inches into two strips, each one inch wide, and submit the leather to a tearing strain: if of the best grade with respect to quality of hide, and quality of tanning and currying, it will have great power of resistance; but if torn, then most of the fibres will not pull out, but will break, because they are thoroughly united to each other by gummy oil—and if, in the tearing strain, the fibres pull out to a great extent, that is an indication of imperfect or incomplete currying, though the original quality of the tanned leather may have been good, for a poor piece of leather tears easily, and a majority of the fibres break short off. A final and conclusive evidence consists in testing the fibres themselves, by seizing them with the fingers at the place of rupture and subjecting them to a breaking strain. In a piece of material which is of really poor quality the fibres have little strength, and this is easily perceptible.

**THE WINTER'S LUMBERING OPERATIONS.**

The Fredericton *Gleaner* gives a very correct idea of the winter's lumbering operations throughout the province when it says they will be small. It says:—"Last season the logs that had been held over in the streams the past winter came into market, on account of the high water, and the increased stream driving facilities. In fact many logs came down the rivers that had been on the bars and islands for four or five years. The market was flooded, and when the sawing season was over, there was a very small demand for this product. Again, besides the market being flooded, there has been an advance in wages, men being hard to get and also an advance in prices of farm supplies, especially in grain. The operator sees no inducement to cause him to go into the business,

especially, from these and other reasons, very few comparatively have gone into business. Old logging grounds, during deep snow, where much land had to be gone over to fill the contracts, will be shunned this year, and the reserve blocks will be held until there is a better prospect of higher prices. A poor winter, cut of course affects the coming summer mill business, but there may be a chance for the latter before the season closes. This winter so far has been a good one for hauling, but the snow is getting quite deep, for there is a great risk during the best seasons that the snow may impede all operations, and this season being now about three feet on an average, and our greatest snow fall is the next two months. More attention will have to be given to farming, and then the prosperity of the province will not be so much affected by the decline in the lumber market. Many of the lumbermen of this vicinity have given up the business, and remained at home this winter and those who have accepted contracts have gone far below their usual quantity. With the approach of spring, and the opening up of the rivers and starting of the mills a brighter outlook will be presented than at the present time."

It may be added that we are now realizing the effect of operators on New Brunswick waters being obliged to pay over one hundred per cent. more stumpage on spruce logs than is paid in any other province. The result of this drawback did not, at first, appear to an extent sufficient to attract general notice, but they are now manifest. New Brunswick operators cannot go on in the face of low prices and the competition of Quebec and Nova Scotia, where the trade has to pay less than half the stumpage exacted in this Province. It is, therefore, not a matter of wonder that New Brunswick is losing its trade in spruce deals, while both Quebec and Nova Scotia are increasing theirs. This is the most potent reason why our lumber operations, as well as our lumber shipments in New Brunswick are falling off.

**Timber and Deal Shipments from Montreal During Season 1890.**

	Deals Ptg. Stds.	Timber Loads.
Dobell, Beckett & Co....	24,000	7,800
John Burstall & Co.....	19,000	1,770
R. M. Cox & Co.....	11,500	—
Smith Wade & Co.....	5,300	—
W. C. Edwards & Co....	5,200	—
W. & G. Sharples.....	5,000	—
Watson & Todd.....	3,200	—
Robert Reford & Co....	1,600	—
Sundries.....	2,500	—
Total.....	77,500	9,570

**Quebec Stocks Wintering 1890-91.**

Article	1888.	1889.	1890.	Average of 5 1885-9.
Oak . . . . . cub. ft.	824,283	596,399	750,000	848,823
Elm . . . . . "	241,571	238,735	450,000	490,064
Sq W Pine " "	2,580,591	3,146,676	4,800,000	4,649,277
Wy W Pine " "	1,226,900	1,914,001	3,500,000	2,289,200
Red Pine " "	464,691	653,918	600,000	450,554
Pine dls. Q stds	711,170	693,197	250,000	765,813
Spruce " "	1,248,674	1,159,682	750,000	1,101,932

The stock of Birch may be taken as *nil*, and of Ash, that there are only two small lots wintering.

—O. S. Laycock has leased his dock and large yard at Black Rock, N. Y., for a term of years to the Proctor Lumber Company, which is a new concern made up of dealers in Toronto, Ottawa and Ogdensburg, which is already in the field for a charter from the state, and bidding for business. W. H. Proctor, of Ogdensburg, will be resident manager of the concern, which will handle lumber from the Georgian Bay district, where some of the members are largely interested. Laycock will retain some stock in the company and assist in the management. The Laycock Lumber Company is not affected by the lease, and will continue as before in the timber business, O. S. Laycock opened this yard last spring for handling pine, but concluded that he would do quite as well to confine most of his attention to the old company, though he sold a large amount of lumber at the new yard.



### SUCCESSFUL MILL MANAGEMENT.

The portable saw mill, as is often alleged, is not altogether responsible for all the poorly manufactured hardwoods thrown upon the market. While much inferior lumber may, says an exchange, and probably does emanate from that source, it is equally true that some of the largest and best-equipped mills in operation are turning out lumber that is far from perfect. There are various reasons for this. One is a policy of forcing a mill to saw to its utmost capacity, sacrificing quality to quantity. It does not require much common sense to perceive that it is far better to saw 75,000 feet of lumber a day, and have it perfect in thickness and intelligently graded, than to produce 100,000 feet and obtain mis-cuts and low grades generally.

Again, there are large mills where may be found a theorist in the office, a practical foreman in the yard and a bum sawyer at the lever. Between the office and the foreman there is a constant variance of opinion, while the sawyer is butchering logs and drawing his wages. The sawyer knows that, while his superior is capable of grading and piling lumber, he cannot take the lever and illustrate the proper manner of sawing a log. The remedy in such cases is to employ a mill foreman capable of operating every machine in the mill. It requires brains to fill such a position, and brains of any account can not be had for a song. If low priced sawyers are employed, a first-class foreman by all means should be had, but it is better and cheaper in the end, to employ good sawyers, filers and foreman, and permit them to follow the dictates of judgment gained by years of practical experience. There are good mills and first-class foreman and sawyers struggling to do themselves justice, simply because the powers that be are forcing them to follow theoretical lines.

The foreman should be a man who, in a pinch, can run a band or circular saw, edger or any other machine used. He should be able to direct the turning and sawing of a log so as to get the largest amount of good lumber out of it, and, following the boards and plank to the edger, prevent an operator from spoiling lumber by idiotic ripping. All this can be brought about by the employment of good mill hands and sawing not over 60 per cent, of the forced capacity of the mill.

### ABOUT CIRCULAR SAWS.

TIMBERMAN.

The successful working of machinery at all times depends much upon the conditions under which it is used and the care bestowed upon it. If the manufacturer were always sure that his machine would fall into the hands of expert and skilful men, who thoroughly understands the conditions required in order to obtain the best results, there would be less anxiety on his part and less occasion for fault finding on the part of the purchaser. Probably no class of manufacturers are subjected to more annoyance from these causes than the manufacturers of circular mill saw. No two mills will be found where the working conditions under which the saw is required to perform its work are alike, and it is impossible for the saw maker to always know just what those conditions are.

It is true that if the saw maker is informed just what speed the saw is to run, the kind of lumber to be sawed and the rate of feed required, he may adjust the tension of the saw approximately to those conditions so that if everything else is favorable, a saw may start off and perform its work in a satisfactory manner. But there are so many other things that may operate against it, that when taken into consideration, it is a wonder that so many start off satisfactorily and fulfill the conditions required of them.

While imperfect collars and a carriage out of square with the mandrel are important factors that are frequently met with, often preventing the new saw from working in a satisfactory manner, yet these are matters that may be easily remedied by an experienced sawyer. But the principal difficulty in most cases is in the tension. A saw maker may give the saw a proper tension for a certain speed, but what assurance has he that that same speed will always be kept up? Any experienced sawyer knows that a saw hammered to the proper tension to run six hundred revolutions per

minute, everything else being equal, will work well if that speed is maintained, but if he attempts to run the same saw with the same tension at a speed of four hundred revolutions per minute he will find the conditions entirely changed and the chances are that it would not work at all.

And just here is where much of the trouble with mill saws originates. Hundreds of mills all over the country may be found where the power is inadequate to maintain a uniform speed at all times and under all conditions, especially so with a class of mills that are operated by water power. The speed is irregular and cannot be depended upon. It may be all right when the saw is running idle or it may be kept up in small sized logs, but when a large log is being sawed the speed may run down one-half before the saw is half way through the log.

Now how can a saw be expected to stand up to its work under such conditions? The only practical remedy that can be suggested in cases of this kind where the power cannot be increased, is to decrease the feed or have a variable one that may be adapted to the size of the log, but by all means keep the saw up to its regular speed. Finding fault and writing ugly letters to the saw maker will not help the matter one particle, for it should be understood that no saw maker can adjust a saw to a tension that will work well under a speed varying from four to six hundred revolutions per minute.

The practice of stopping the feed entirely to allow the saw to recover its speed and then slashing it into the log and slacking it down again is a bad one, no matter how well it is practiced. It is much better to adapt the feed to the power so as to allow the saw to run at all times at its regular speed.

### BRITISH COLUMBIA LETTER.

NEW WESTMINSTER, Dec. 23rd, 1890.

The lumber business continues brisk, all the mills running full time and having orders for a long time ahead.

The Brunette Saw Mill Co., of this city, keep in the line of progress and improvement. This week they have lighted the greater part of their yard and all their buildings with electric light made on the premises. This is the first used in this city. Their plant consists of a "Compton" of four arc and 182 incandescent lights. The mill and remainder of the yard will be lit also next week. The fine new mills of the company continue to turn out excellent work, and are fast earning a reputation for accuracy and finish that was impossible to produce with their old mill.

It is likely that a new company, to be known as the Canadian Pacific Lumber Co., will build a mill in close proximity to the Brunette Saw Mill Co. Mr. Andrew McLaughlin, who has been connected with the management of the Royal City Mills for some years, will assume the management of the new company. Early in January Mr. McLaughlin will leave for the East, to purchase machinery for the new mills. The company have secured some valuable timber limits, and before spring will be on a good footing in this respect.

Messrs. James Harris & Co., of St. John, N.B., the extensive car builders, are about closing negotiations with the Royal City Planing Mills Co. for their supply of car sills, etc. This will be the greatest distance the British Columbia fir is shipped in Canada. The Barney-Smith Car Mfg. Co., of Dayton, Ohio, continue to receive consignments of it from this firm. The McKinley duty has seemingly not affected this article so seriously as to prevent its being shipped as before.

Mr. J. W. McRae, of Ottawa, well known in Eastern lumber circles, has just paid British Columbia a visit. He expressed the opinion that the fine fir, spruce and cedar of this coast would soon make a name for themselves in any market, and predicts a good future for the lumber trade of this province in general. He was delighted with New Westminister, and its favorable situation seemed to impress him very much, and rightly so.

The building of Messrs. Dixon & Purdy's mill, near

Mission Station on the line of the C.P.R., is making good progress.

The McLaren-Ross Lumber Co. have been sawing pretty steadily lately, but not to their full capacity. They are still erecting dwellings for their employees.

The employees of the Royal City Planing Mills Co. have formed a debating club and reading room. The rooms will be comfortably furnished and debates held weekly.

The work of laying tracks for the electric street railway in this city began on the 15th inst., and is progressing rapidly. The Trail of 35 pounds per yard is strongly objected to by the City Council, and it is not yet known what decision will be come to in the matter, as the railway company contend it is up to all the requirements of the times.

The shipments of lumber from Burrard Inlet, B.C., during the month of November were 1,591,344 feet to Melbourne, Australia.

The machinery for a shingle mill has been brought in by R. Cunningham for a mill on the Skena river.

The Davies-Sayward Mill Company, on Kootenay Lake, has let a contract for 5,000,000 feet of logs, to be delivered at the company's sawmill at Pilot Bay. McLean & Flager will undertake the work.

G. F. Slater, of the Vancouver Shingle Mill, is putting in saw mill machinery on a more extensive scale, for the manufacture of all kinds of lumber. Heretofore attention was directed only to the manufacture of shingles and fine cedar lumber.

The Vancouver *World* says: "Phillip Kelly and Duncan Box, timber rangers for the Canadian Pacific Lumber Company, returned on Saturday from an extended trip up the coast and inland, locating claims for that company. They met with good success, and a party of surveyors will leave in a day or two for that part of the province. The company propose to erect a large saw mill at the mouth of the Amacon river, down which the logs will be floated to the mill yard. Ships can load in these waters.

A. St. Geo. Hamersley, a prominent barrister of Vancouver, is now at Ottawa in conference with some English capitalists there in reference to an extensive dry dock and harbor scheme at Vancouver, which will involve an expenditure of a sum in the millions. This has been under consideration for some time and seems to be just now taking a shape which augurs for its success.

Grading on the Mission branch of the C. P. R. is almost completed to the boundary. The border town sites, Huntingdon, on this side of the line, and Sumas City, immediately opposite, are experiencing something of a boom in consequence of railway construction, and some improvements are going on in both places. The Huntingdon Mill Company are working on an order of 300,000 feet of lumber for planking streets in the "twin cities."

We notice that the CANADA LUMBERMAN has again changed the location of its offices, which are now situated in one of the finest buildings in Canada. We wish you the compliments of the season and a prosperous New Year.

H.G.R.

### A "GOLDEN" RULE FOR ADVERTISERS.

Said a gentleman, the managing man of a concern, "The only rule I have for determining whether or not a paper is a desirable one for our house to use as an advertising medium is to ascertain if the paper, upon examination, has interest for me as a reader. I go through its columns carefully, and consider what is being presented from month to month to its subscribers and readers, and then attempt to conceive of the kind of people who are likely to take the paper in order to obtain such information or such reading matter. I believe," he continued, "that this rule enables me to weed out many papers which have only a free circulation, and some of those also which do not employ editors, or which do not make any real attempt to take high rank as periodicals. When I find a paper that I think I could afford to pay for as a subscriber on account of the matter it contains, I am impressed with the idea that it circulates among a class that I can afford to pay for to reach with my advertisement."



TRADE REVIEW.

Toronto, Ont.

TORONTO, Dec. 31, 1890.

CAR OR CARGO LOTS.

Table listing lumber prices for Toronto, Ontario, including items like 1 1/2 inch clear pickets, 1 1/2 inch thicker, three uppers, etc.

YARD QUOTATIONS.

Table listing yard quotations for Toronto, Ontario, including items like Mill cull boards & scantling, Dressing stocks, Shipping cull boards, etc.

Hamilton, Ont.

HAMILTON, Dec. 31, 1890.

Table listing lumber prices for Hamilton, Ontario, including items like Mill cull boards and scantlings, Shipping cull boards, etc.

Ottawa, Ont.

OTTAWA, Dec. 31, 1890.

Table listing lumber prices for Ottawa, Ontario, including items like Pine, 1st qual., 2nd, shipping culls, etc.

Montréal, Que.

MONTRÉAL, Dec. 31, 1890.

Table listing lumber prices for Montréal, Quebec, including items like Pine, 1st quality, 2nd, shipping culls, etc.

St. John, N. B.

ST. JOHN, Dec. 31, 1890.

Table listing lumber prices for St. John, New Brunswick, including items like Spruce gear, Pine, Deal ends, etc.

Vancouver and New Westminster, B.C.

NEW WESTMINSTER, Dec. 31, 1890.

Table listing lumber prices for Vancouver and New Westminster, British Columbia, including items like Carload and ship rates, Bridge and Wharf Plank and Timber, etc.

Albany, N. Y.

ALBANY, N. Y., Dec. 31, 1890.

Table listing lumber prices for Albany, New York, including items like Boards, 1x10 in. each, Joist 4x6, etc.

Buffalo and Tonawanda, N. Y.

BUFFALO, Dec. 31, 1890.

Table listing lumber prices for Buffalo and Tonawanda, New York, including items like Clear, 1 in. & clear, Dressing, 1 to 2 in. all widths, etc.

Saginaw, Mich.

EAST SAGINAW, Dec. 31, 1890.

Table listing lumber prices for Saginaw, Michigan, including items like Uppers, Common, Shipping Culls, Mill Culls, etc.

New York City

NEW YORK, Dec. 31, 1890.

Table listing lumber prices for New York City, including items like 1/2 in. clear, 1 and 1 1/2 inches, 1 1/2 and thicker, etc.

Boston, Mass.

BOSTON, Dec. 31, 1890.

Table listing lumber prices for Boston, Massachusetts, including items like Uppers, 1 in. & 2 in., 3 & 4 in., etc.

Oswego, N. Y.

OSWEGO, Dec. 31, 1890.

Table listing lumber prices for Oswego, New York, including items like Three uppers, 1 1/2, 1 1/2 & 2 inch, Pickets, 1 1/2, 1 1/2 & 2 in., etc.

## GENERAL NEWS NOTES.

Miller & Jamieson have again commenced operating their custom saw mill at Cornell, Ont.

The lumber trade in the Upper Ottawa is reported as being very dull.

Very large quantities of cedar posts are being cut in and around Plotterville this winter.

The cedar trade on the Manitoulin Island is as brisk as usual this winter.

Very little shipping of lumber has been going on at Sturgeon Bay recently, owing to a scarcity of cars.

The Rathbun Co., of Deseronto, Ont., are going to make a large exhibit at the Jamaica Exhibition.

Lumber was exported from Peterboro', Ont., during the quarter ending Sept. 30th, amounting to \$26,599.

James Playfair & Co., Sturgeon Bay, Ont., took out a large quantity of telegraph poles last fall.

The Cottage Planing Mills at Huntingdon, P.Q., have been destroyed by fire.

Two mills at Severn Bridge, Ont., have finished their cut for the season. Mr. Rainey's mill ran until the river became frozen.

Lumbermen report a very slight improvement in the number of cars obtained for their trade, the last month.

It is understood that with duty on pine lumber at \$1 a thousand, there will be considerable shipped to Chicago from Algoma mills.

The E. B. Eddy Mfg. Co.'s old "Corroy" limit on the Madawaska river, and the Clyde limits, have been sold to T. McGuire & Co. for \$30,000.

Malkin Bros., of Hfracombe, Ont., are preparing to do quite a timber business at Axe Lake this season, and are paying good prices for pine.

The Rathbun Company will cut a large number of logs on the Moira river this year, and operations will be about the same on the Trent waters.

The whistle at the lumber yard at Ogdensburg, N.Y., which blows for fires, can be plainly heard at Prescott, Ont., 22 miles away.

The Longford Lumber Co., of Orillia, Ont., has paid out about \$500 per week for basswood bolts since the snow came.

Very little work is being done in the woods east of Winnipeg this winter. Wood and tie contractors say it is the dulllest season they have ever experienced.

Canadian, English and American capitalists are constantly on the look-out for desirable timber limits throughout British Columbia.

Bear river and Weymouth river, N.S., are still open to navigation. The lumber trade at these places is brisk, and several vessels are being loaded for the West Indies.

The Georgian Bay Lumber Company, Waubashene, Ont., last year ran sixteen camps. This year they will run only four and will employ none but married men.

The Pacific coast lumbermen say that last year they cut over 2,000,000,000 feet of lumber; during 1891 they expect to largely exceed this quantity.

During the present winter the Collins' Bay Rafting Co. will build a tug-boat to take the place of the steamer McArthur, burned a short time ago. The new boat will cost \$25,000, and be composed principally of steel.

It is said that the negotiations which have been going on for some time between the Rathbun Co., of Deseronto, and the Gilmour Co., of Trenton, for the purchase of the latter's mills and limits, are almost concluded.

Saginaw parties who are interested in lumber production at Duluth, report the past season's output at that point the largest in its history, being 282,987,159 feet, or 52,919,150 feet more than in 1889.

The shingle mill on Vancouver Road, owned by Simons, Burpee Elkin & Smith, will soon be operating. If the production of shingles proves as extensive as the name of the firm the output will be very large.

Mr. H. B. Beeton, representing the British Columbia Government in London, Eng., is engaged in collecting all possible data regarding lumber, timber limits, saw mills and their outputs, etc., for Whitaker's almanac.

The Vancouver News Advertiser understands that the large saw mill owners on Puget Sound are about to form a combination to close down the small mills. Some time ago the small mills proved that they could cut lumber cheaper than their larger rivals

during dull seasons, and this is the reason for this latest scheme.

The propeller Missouri, which was burned a Sandwich, Ont., recently, was an old timer. She was built in Buffalo in 1857 and has traded with Buffalo and other Lake Erie ports ever since she came out, carrying lumber. She was owned by Capt. Baker, of Detroit, and was insured for \$7,000 against fire.

Mr. George B. Campbell, agent for J. & G. Bryson, who has been travelling limits for the past four months in the new country lately sold by the Quebec Government, reports plenty of good timber on some of the limits. It is his opinion when that country is opened up that the Black River road, by Caldwell and Cavreau depots, will be the shortest and best route to reach it. There is now a first-class level land road to the headquarters of the Dumoine, and it will cost very little to carry it through from there.

The lumber business at Quebec has been very unsatisfactory this year. Dealers paid higher prices to manufacturers than were justified by the state of the markets in which the product must be sold. Apathy among buyers in the United States was sorely felt, and English markets were likewise sluggish. Local financial complications and demoralization also had injurious effect. It is said that only four rafts of Ottawa white pine changed hands at Quebec during the whole season. Excessive stocks will be held over this winter, and woods operations will be curtailed.

## FIRE RECORD.

The Osgoode shingle mill, owned by Mr. Joseph Larose, of Hull, was burned to the ground on the 13th Dec. The loss is estimated at \$4,000, and the fire will throw 15 men out of employment. Mr. Larose is partly covered by insurance in a local company.

William Dunlop's large saw mill at Thorndale, Ont., together with a considerable quantity of lumber, were destroyed by fire on Dec. 21st.

The Dixon lumber and shingle mill, at Kimmount, Ont., lately purchased by R. J. Mills, was burned Dec. 21st. The mill was just ready to start operations. No insurance. The losses are:—R. J. Mills, on mill, boiler and machinery, \$3,000; W. T. Craig, shingle mill and saws, \$500; Mansfield Wood, \$100.

## PERSONALS.

Mr. J. D. Shier, Bracebridge, was among the callers at this office during the month. He reports the lumber business in his locality picking up, especially in the line of shingles.

Mr. P. J. Shannon, of the Rathbun Co. agency, before leaving Brockville for Seattle, was presented with an elegant souvenir in the shape of a handsomely wrought C. M. B. A. emblem and a flattering address from the members of the board of trade of that town.

Mr. R. J. S. Drinkwater, of the firm of Drinkwater Bros., Orillia, favored the LUMBERMAN with a call during the month. He reports the lumber business quiet in his section, but makes no serious complaints.

Mr. R. Heaton, of Heaton Bros., Cayuga, the well known planing mill men, dropped in on us during the month and "squared up" for another year.

## THE WOODMAN.

Far removed from noise and smoke,  
Hark! I hear the woodman's stroke,  
Who dreams not, as he fells the oak,  
What mischief dire he brews.

How art shall shape his falling trees,  
In aid of luxury and ease,  
He weighs not matters such as these,  
But sings, and hacks, and hews.

Perhaps, now felled by this bold man,  
That tree shall form the spruce sedan,  
Or wheel-barrow, where oyster Nan  
So runs her vulgar rig;  
The stage, where boxers crowd in flocks;  
Or else a quack's, perhaps the stocks,  
Or posts for signs, or barber's blocks,  
Where smiles the parson's wig.

Thou mak'st, bold peasant, oh! what grief  
The gibbet, on which hangs the thief;  
The seat, where sits the great lord chief,  
The throne,—the cobbler's stall;  
Thou pamp'rest life in every stage,  
Mak'st Folly's whims, Pride's equipage,  
For children toys, crutches for age,  
And coffins for us all.

Yet justice let us still afford,  
Those chairs, and this convivial board,  
The bin, that holds great Bacchus's hoard,  
Confess the woodman's stroke;  
He made the press, that bleeds the vine;  
The butt, that holds the gen'rous wine;  
The hall itself, where tipplers join  
To crack the mirthful joke.

—DIBDIN.

# The Galt Bros. Co., Johnston, & Watson

(LIMITED.)  
GALT, ONT.

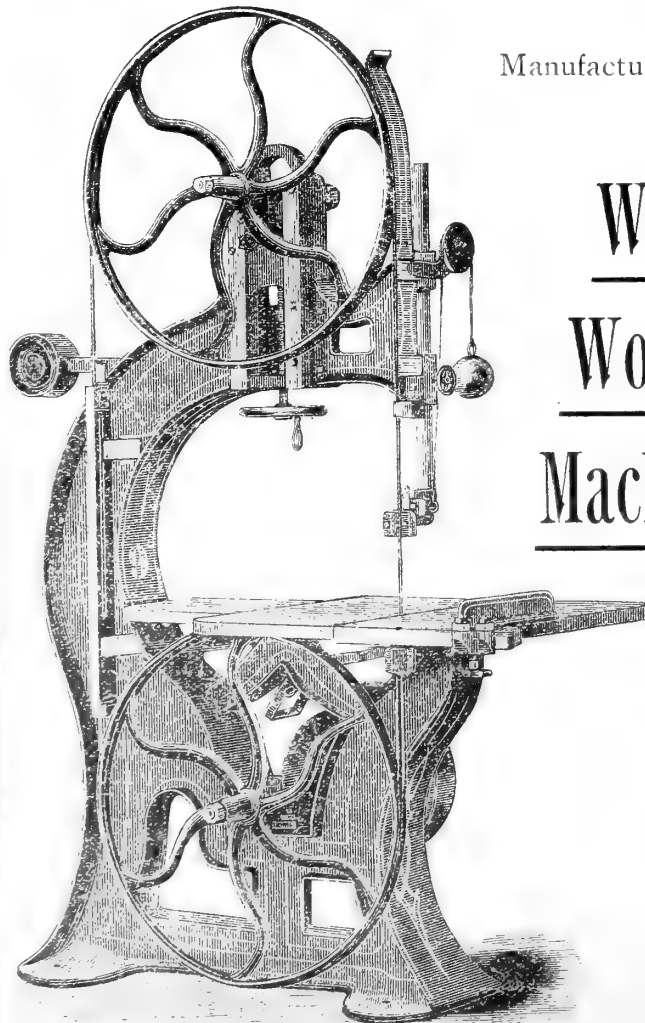

Manufacturers of all kinds

of

Wood

Working

Machinery.

# Johnston, & Watson

THE

ART

PRINTERS

67 Adelaide St. W.

TORONTO.

Fine Power Presses and  
the Latest Designs in Type.

Book, Municipal, Commer-  
cial, Law and

## General Job Printing

of every description.

## Lumbermen

and Manufacturers generally  
order from us.

Our facilities and practical  
knowledge of the business are  
such as to execute any Job in  
in the Printing line in the  
finest style of the Art.

Call or write us for prices  
before ordering elsewhere.

CORRESPONDENCE

SOLICITED.

**WANTED AND FOR SALE.**

Advertisements will be inserted in this department at the rate of 15 cents per line each insertion. When four or more consecutive insertions are ordered a discount of 25 per cent. will be allowed. This notice shows the width of the line, and is set in Nonpareil type. Advertisements must be received not later than the 27th of each month to insure insertion in the following issue.

**HARDWOOD** lumber, bought, sold or received on consignment, **TUCKER DAVID**, lumber commission merchant, 313 Eleventh Ave., N.Y.

**WANTED—TO BUY.**

**GOOD** Canadian Timber Limits and Georgian Bay saw logs. Address, **BEN BIRDSALL**, Whitney Building, Detroit, Mich.

**CAPITAL WANTED.**

**WANTED**—A partner with about \$12,000 capital, to take half interest in a well established lumber and shingle business in British Columbia. Timber Limits now secured to run mill 5 to 7 years. For particulars address, **H. H. S.**, BOX 297, Vancouver, B. C.

**WANTED—PARTNER**

**WITH** \$50,000 to \$75,000 capital to invest in timber limit and saw mills on line of C.P.R. in British Columbia, with three practical men. Best thing on line of C.P.R. Address **BOX 276**, Trenton, Ont., Canada.

**TAMARACK TIMBER.**

**THE UNDERSIGNED** wishes to purchase a large quantity of Tamarack Logs, from 8 to 20 feet long, the smallest to be not less than 13 in. at the top. A good price will be paid, delivered at Shelburne, Melancthon, Corbeton and Riverview mills. **A. F. SPEARING**, Shelburne or Riverview.

**FOR SALE** in the village of South River, a first-class saw and shingle mill, in good running order; situated on the bank of South river, Farry Sound district. For particulars apply to **C. W. Burns, jr.**, South River, Ont.

**FOR SALE**—Steam saw mill and bush lot in the township of Egremont. Apply to **Adam Watson**, Durham.

**STEAM MILL**—for sale, in the village of Cremona, with a good lumber and log yard; cutting capacity good; terms reasonable. For particulars apply to **J. D. Greenless**, Alliston, Ontario.

**MUST BE SOLD** at any sacrifice, heavy saw-mill machinery; first-class site; good stock of logs, and 200 acres of land; at junction of G.T.R. with C.P.R. Apply **E. GARROW**, Nipissing Junction P.O., Ont.

**WANTED**—Competent man to run saw mill in British Columbia, at a rate per M. Must be proficient in all branches of the lumber business. Man with family preferred. Address **A. JONES**, LUMBERMAN Office, Toronto.

**WANTED—FOR CASH—HARDWOOD**

**HARDWOOD LUMBER** Squares and Dimension Stock, principally walnut squares, 14 to 7 in. thick, 12 in. and upward long. Apply for specifications and prices. State full particulars of stock on hand. **P. O. BOX 1,144**, New York.

**UNDERSIGNED** wants to buy or lease saw mill where good business can be done. *Advertiser*, Leith, Ont.

**RAILS AND CARS FOR SALE.**

Light Steel Rail, for Tramways; good order. Cars for lumber, cheap.

**JOHN J. GARTSHORE**,  
49 Front St. West,  
Toronto.

**WANTED.**

**QUEBEC BIRCH**—Those who can furnish choice lumber are invited to correspond with

**JOHN S. MASON & CO.**,  
246 Eleventh Avenue,  
New York City.

*Pine Timber Limits*  
**FOR SALE**

On Upper Ottawa running back from Birch Lake, Main Ottawa river, 300 miles—selected years ago—well timbered, good streams for driving.

Terms of payment easy

Apply to

**J. BELL FORSYTH & CO.**

QUEBEC.

**TIMBER \* LANDS FOR SALE**

**5000 Acres of Timber Lands on the Manitoulin Island,**

Patented and unpatented, are offered at the Low Price of

**\$5.00 PER ACRE.**

Some of the lots have timber on them worth \$20 per acre, and the land is of fair quality for farming when cleared.

The Dominion Government having recently taken off the Export Duty on Telegraph Poles, Railway Ties, Shingle Bolts and Saw Logs, the value of the timber on the island is doubled, owing to its great facilities for shipment to Detroit, Chicago, Toledo, Buffalo, Cleveland and all Lake ports.

The late owners, Messrs. Wm. and Robert Henry, are both deceased, and there being no one to carry on their business, these lands will be sold low, in Block to close out the estate. Tenders solicited and purchases liberally dealt with. All necessary information can be obtained from the trustee and Solicitors.

Messrs. **FRANCIS & WARDROP**,

Barristers, &c.,

**JAMES MCGEE**, Trustee, Toronto.

**ESTABLISHED 1888.**

**THE INDUSTRIAL REVIEW**

**Thos. E. Powell & Co., Publishers.**

**MEMPHIS, TENN.**

The Most Widely Circulated Commercial, Financial and Industrial Journal in the South.

**THE INDUSTRIAL REVIEW**

Is a Monthly Journal devoted to Trades and Manufacturers.

**IT GIVES SPECIAL ATTENTION**

To the mining interest, the milling interest, the railroad interest, the steel and iron interest, the textile manufacturing interest, the lumber and wood manufacturing interest, the hardware and machinery trade, and is an authority on

Southern Industrial Development.

**TERMS OF SUBSCRIPTION:**

One copy, one year, \$1. Advertising rates on application.



**W. J. KRAMER**  
FINE \*  
**WOOD ENGRAVER**  
21 MELINDA ST. TORONTO.

**COWPER & GREGORY.**  
**RECEIVERS** and Forwarders of Lumber, Lath, Shingles, &c. Unexcelled facilities for shipping by canal or rail. Tonawanda, N. Y.

**A. M. DODGE & CO.**  
**MANUFACTURERS** of and Wholesale dealers in all kinds of Lumber, Lath and Shingles. Tonawanda, N. Y.

**E. & B. HOLMES.**  
**WHOLESALE** dealers in Lumber and Timber. Office, Michigan and Canal Streets, Buffalo, N. Y.

**CHEESMAN DODGE**  
**TIMBER** and Lumber Merchants. Ship and Boat stock, Railroad Ties, &c. Office, 16 West Seneca Street, Buffalo.

**EMMET FLEMING**  
**INSPECTOR** and Commission dealer in Lumber. Office, 251 Louisiana Street, Buffalo, N. Y.

**LAYCOCK LUMBER CO.**  
**MANUFACTURERS** of Pine, Hemlock and Oak Timber up to 35 feet in length. Saw Mills: Ackley, Pa., Black Rock, N. Y., Gravenhurst, Ont. Office, corner Main and Seneca Sts., Buffalo, N. Y.

**J. & T. CHARLTON**  
**WHOLESALE** dealers in Masts and Spars, Canada Round Pine, &c. Tonawanda, N. Y.

**WILLARD W. BROWN.**  
**202** Michigan Street, Buffalo, N. Y.  
**A. P. & W. E. KELLEY CO.**  
**WHOLESALE** Lumber and Timber. Office, 100 Michigan Street, Buffalo, N. Y.

**C. P. HAZARD.**  
**WHOLESALE** dealer in Lumber, Shingles, Lath and Fence Posts. Commission dealer invited from the C. P. R. Office, 100 Michigan Street, Buffalo, N. Y.

**L. A. KELSEY LUMBER CO., Ltd.**  
**MANUFACTURERS** and dealers in Hardwood Lumber of all kinds. Office, 100 Michigan Street, Buffalo, N. Y.

**BOVEE & HOWDEN**  
**MANUFACTURERS** and Wholesale dealers in Hard and Soft Wood Lumber. Holders of Canadian stocks are invited to write for quotations. Offices at Tonawanda and Le Roy, N. Y.

**THE TONAWANDA LUMBER CO.**  
**MILLS** at East Tawas, Mich. Office, 106 Main Street, opposite N. Y. C. P. R. Station, North Tonawanda, N. Y.

**J. J. TURNER,**  
**Sail, Tent and Awning Maker.**  
251 GEORGE AND 154 KING STREETS, PETERBOROUGH.  
Canoe, Yacht and Boat Sails made to order. Perfect Fits guaranteed.  
Every description of Lumber, Shingles, Lath and Waterproof Clothing.

**Fawcett & Co.**  
**MERCHANT \* TAILORS,**  
269 Queen St. E., Opp. Seaton St., Toronto.

First-Class Goods and Trimmings. Workmanship and Fit Guaranteed. All Orders Punctually Executed.

**HERBERT G. ROSS.** Box 278. **REGINALD C. BLAKER**  
**N. G. ROSS & CO.**

*Real Estate, Fire and Life Insurance, Shipping and General Commission Agents.*

Timber Limits and Farming Lands a Specialty.

A.B.C. Code, Cable address, "Ross."

**NEW WESTMINSTER, - - B. C.**  
CORRESPONDENCE SOLICITED.

**The American Lumber Yard**  
**HAMBURG, GERMANY,**

Offers the best facilities for Yarding and Selling all kinds of  
**American Wood Goods.**

Address:  
**ROSENBACHER & CO.,** **CARL GARTNER, Agent,**  
BANKERS, Hamburg. Hamburg

**GEORGE McWILLIAMS**

(Successor to Wm. Forsyth.)

MANUFACTURER OF

**TAPER PIKE POLES,**

**PEEVEY STOCKS, CANT HOOK AND GAFF HOOK HANDLES.**

The only Successful Taper Pike Pole Manufactured.

Peterborough, = = = Ontario.

**Menasha Hickory Pulleys**  
We make the only hardwood bent rim spoke arm split pulley, only small split pulley, only wooden hangers in the market. Send for discounts & circulars.  
**Menasha Wood Split Pulley Co.**  
MENASHA, WISCONSIN.



# The Only Successful Kiln for Drying Oak and other Hardwoods

**"THE ANDREWS"**

NEW LUMBER

## DRY-KILN

It is not only the only kiln that duplicates nature in drying, but also the only one that requires no special attention, nor does it waste heat by a special chimney. The air circulates through the lumber, and the moisture absorbed from it is extracted from the air by natural methods. You can not afford to be without it.

Our Process Duplicates Nature.

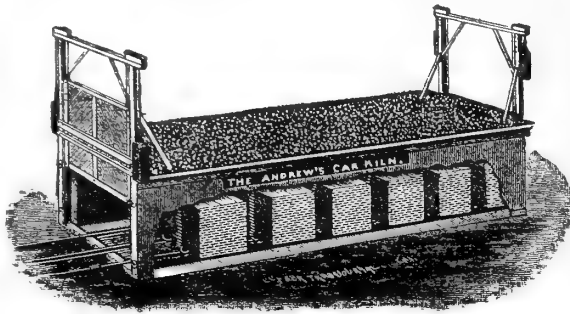

Outside View of the Andrews Kiln.

The following well-known furniture manufacturers have recently purchased the "ANDREWS KILN."

- Estey Manufacturing Co., - - - Owasa, Mich.
- East Shore Furniture Co., - - - Manistee, Mich.
- Universal Tripod Co., - - - Grand Rapids, Mich.
- Grand Rapids School Furniture Co., Grand Rapids, M.
- New England Furniture Co., - Grand Rapids, Mich.
- Milwaukee Chair Co., - - - Milwaukee, Wis.
- Oshkosh Furniture Co., - - - Oshkosh, Wis.
- Skandia Furniture Co., - - - Rockford, Ill.
- Story & Clark Organ Co., - - - Chicago, Ill.
- Rock Falls Manufacturing Co., - - - Sterling, Ill.
- Courey & Birely Table Co., - - - Shelbyville, Ind.
- Southern Spring Bed Co., - - - Atlanta, Ga.
- Sidney School Furniture Co., - - - Sidney, Ohio.
- New Richmond Church Furniture Co., N. Richmond, O.

## A. H. Andrews & Co., Proprietors and Manufacturers

215, 217, 219, 221 Wabash Ave., CHICAGO, ILL.

## The Casselman Lumber Co.

CASSELMAN, ONT. Successors to FLATT & BRADLEY.

ESPECIAL GOOD FACILITIES FOR SHIPPING.

HEMLOCK BILL STUFF OF EXCELLENT QUALITY.

ALSO MANUFACTURERS OF

PINE, SPRUCE, ASH, MAPLE AND OTHER HARDWOODS.

CORRESPONDENCE SOLICITED.

J. W. MAITLAND  
H. RIXON

J. G. AINSLIE  
W. STODART

## Maitland, Rixon & Co.,

Owen Sound, Ont.

## Saw Millers AND Lumber Dealers

All kinds of Building Material kept in stock.

WE MAKE A SPECIALTY OF

LONG BILL STUFF IN ROCK ELM, PINE, CEDAR AND HEWLOCK.

QUOTATIONS FURNISHED ON APPLICATION.

## F. J. DRAKE,

PATENTEE AND MANUFACTURER OF

## SAW, SHINGLE AND LATH MACHINERY

Belleville, Ontario.

### DRAKE'S PATENT DAUNTLESS SHINGLE AND HEADING MACHINE

Capacity from 25,000 to 50,000 per day.

The frame of iron throughout, very heavy and rigid, strongly bolted and braced; carriage very light and strong, made of forged cast steel saw plate, running on steel ways or tracks; will take in a block 18 inches wide and 19 inches long, adjustable for 16 inch or 18 inch shingles.

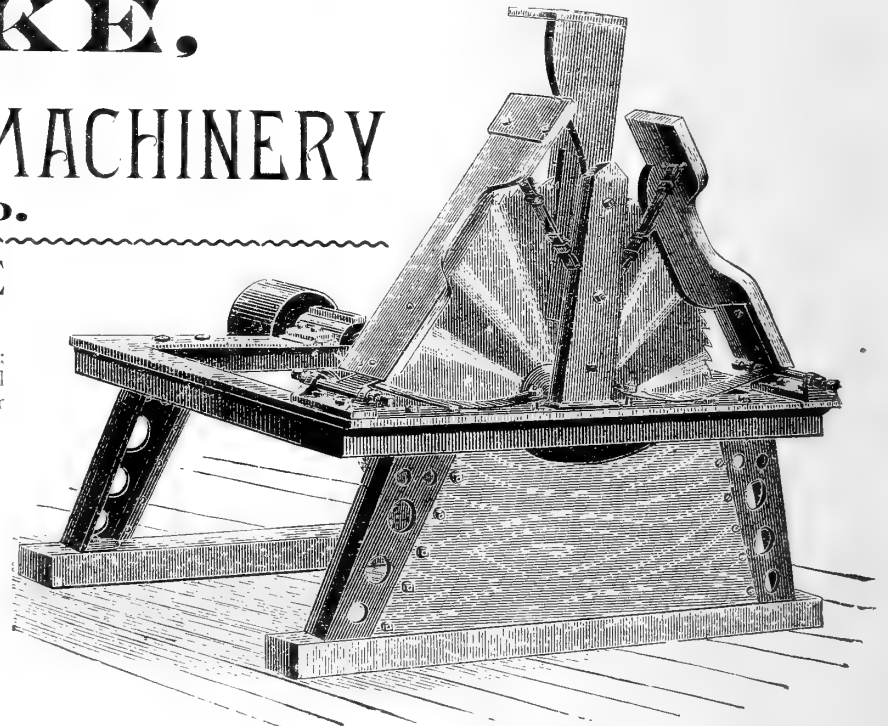
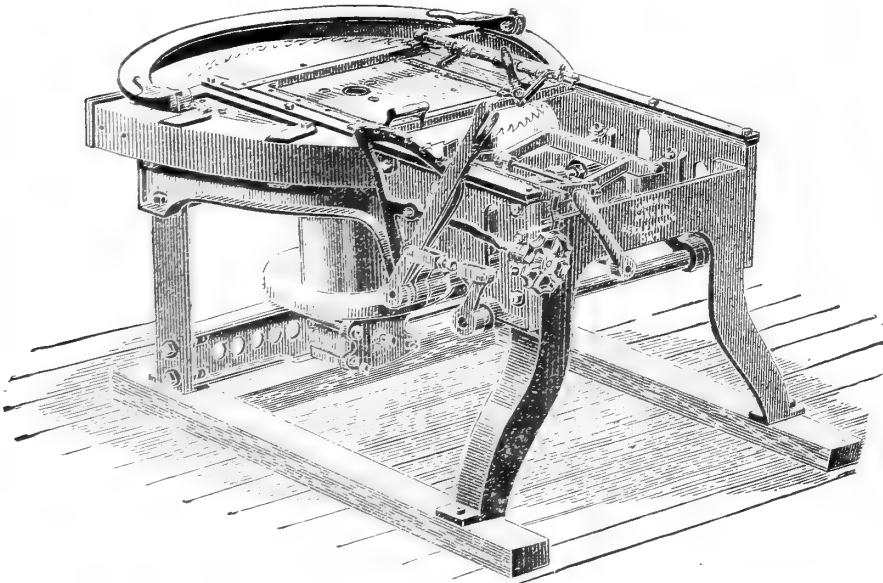

## Drake's Improved Shingle Edger.

With 40 inch saw will make more No. 1 Shingles from the same quantity of timber than any Wheel Jointer in existence.

It has a heavy iron frame made for two operators, two inch steel saw arbor, with extra long bearings; driving pulley 8 inches diameter, 7 inch face, saw 40 inches diameter, 16 gauge, speed, 1,600 per minute.

Mill men who have once used this machine will not use any other. For capacity, removing sap-knots, rot or any other imperfections, for making parallel shingles and economy of stock, it is superior to any other.

Also manufactures other kinds of Shingle Jointers, both self-acting and hand-feed Shingle Machines, Packing Boxes, Drag Saw Machines, Bolters, Stationary and Portable Saw Mills, Table Edgers, Single Edgers, Slab Saw Rigs, Bull Wheel Rigs, Lath Machines, Lath Bolters, in fact a general line of Mill Machinery, with Pulleys, Shafting, &c. Satisfaction guaranteed in all cases. Send for estimates on anything required, and the same will receive immediate attention.



# Friction Pulley Board.

The Best Materials ever used  
for Frictions of all  
\* kinds \*

MANUFACTURED BY

Asbestos  
Mill  
Board.

The **DOMINION LEATHER BOARD COMPANY,**  
Montreal, Quebec.

Steam  
Packing.

SAMPLES FURNISHED.

PLEASE MENTION THIS PAPER.

CORRESPONDENCE SOLICITED

TO MILL OWNERS, MANUFACTURERS

AND ALL WHO ARE USING

*Leather \* Belting*

IF YOU WANT BELTING

Which will Run Straight on the Pulleys,  
Which is Thoroughly Well Stretched,  
Which will not Tear at the Lace Holes,  
Which will give Complete Satisfaction,

— SEND TO —

**F. E. DIXON & Co.**

MANUFACTURERS OF

PATENT LAP-JOINT STAR RIVET

\* LEATHER \* BELTING \*

70 King Street East, Toronto.

Sole Agents in Canada for the

CELEBRATED PHOENIX OIL

The Only Perfect Belt Dressing.

All our Belting is sold at the Canadian price list. Please compare before purchasing. Send for Discounts and our Pamphlet on Belting.

Galt \* Machine \* Knife \* Works.



PETER HAY, - - - GALT, ONT.

THE RATHBUN COMPANY,  
DESERONTO, ONT.,

MANUFACTURERS OF

\* TERRA \* COTTA \* FIRE-PROOFING \*

For Use in Old and New Buildings.

Endorsed by Leading Architects. Absolutely Fire-proof. About as Cheap as Wood or Brick. Weight One-Third that of Brick. Does not Crack on application of Heat or Water. Deadens Noise. Gives Warmth in Winter; Coolness in Summer.

NAPANEE CEMENT COMPANY  
(LIMITED.)

— MANUFACTURERS OF —

**Hydraulic Cement**

PARTICULARLY adapted for Dams, Smoke Stacks, Foundations, Culverts, Cisterns, Cellars, etc.

ENDORSED BY LEADING RAILWAYS AND CONTRACTORS.

ROACH + LIME,

For Building, Plastering, Gas Purifying, Paper Making, &c.

*B. F. Sturtevant's Patent Progressive Lumber Dry Kiln.*

RELIABLE RAPID! CHEAP!

GUARANTEED  
TO DRY

— IN —

Best Manner Possible

ALL KINDS OF  
HARD and SOFT  
WOOD LUMBER.

WRITE FOR CATALOGUE.

91 LIBERTY STREET  
NEW YORK.

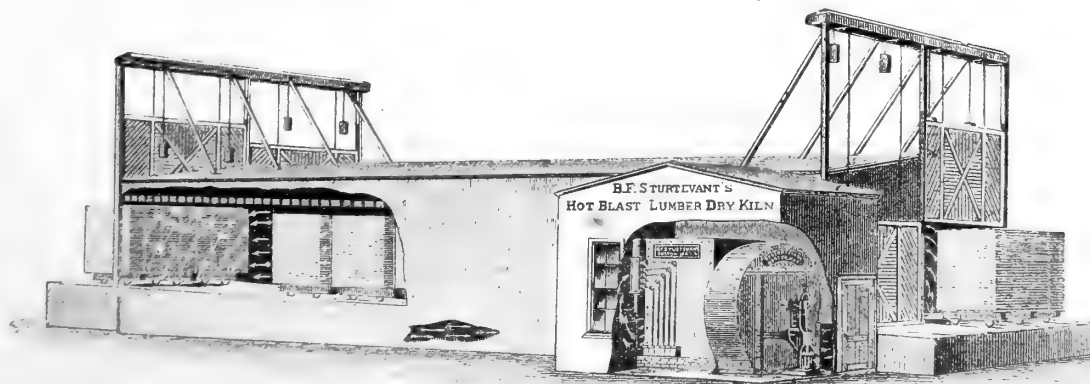

NO WARPING  
CHECKING  
AND BLUEING

— WITH THE

STURTEVANT

Patent Hot Blast

Steam Heating

Apparatus.

31 N. CANAL STREET  
CHICAGO.

B. F. STURTEVANT, Patentee and Sole Manufacturer, 34 Oliver Street, (corner of Franklin street) BOSTON, MASS., U. S. A.  
A. R. Williams, Soho Machine Works, Toronto, General Agent for the Dominion.

# The Best is the Cheapest

This is true. Especially in Machinery.

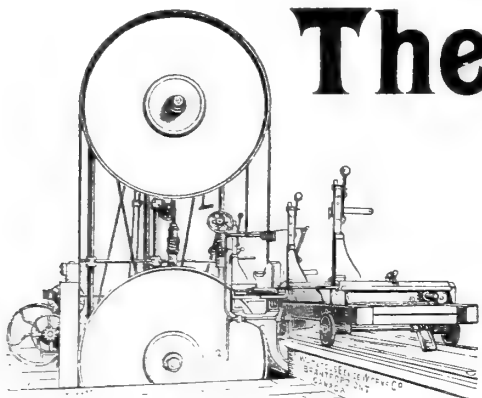

1844

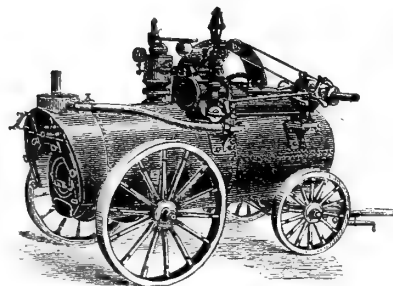

1890

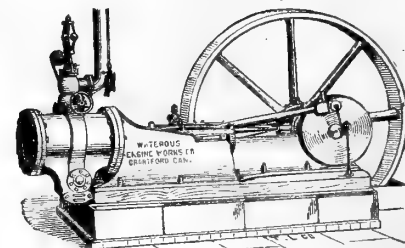

## OUR SPECIALTY

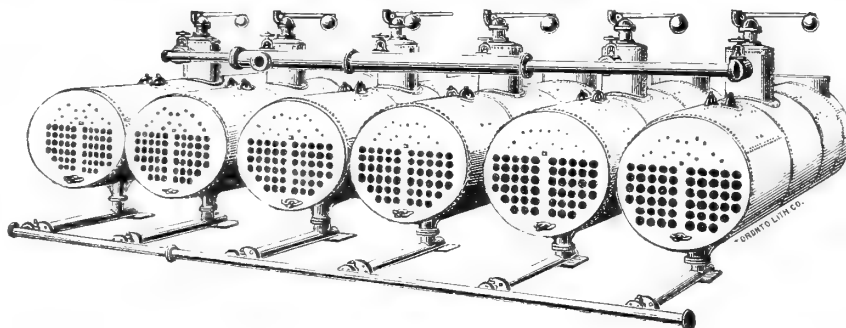
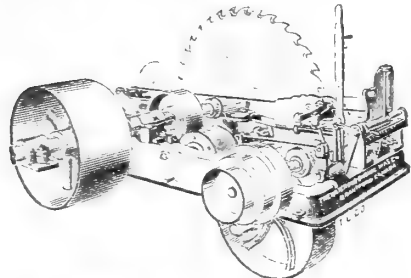

Portable Engines. 6 to 50 h. p. All descriptions of boiler work, burners, tanks, &c.

## SAW MILL Machinery

**BAND, Circular and Upright**

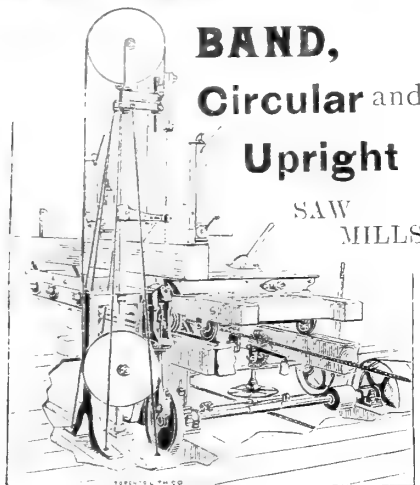

**Shingle and Lath Mills.**

Our maxims have been "Nothing can be too well made." "Make the machinery as it should be in every part and then set the price at a fair profit considering the cost." "Never cut the price and then cheapen the production to suit the price." "That mill men and people generally can and do appreciate a good article and will generally buy it, even if first taken in with some cheap machine said to answer as well," After forty years of successful business life on the same premises, conducted on these lines, we have no reason to regret having started out with this standard before us. It has given us a reputation we are proud of, one that we cannot afford to injure ; and one that has kept us in full operation during these years, when many shops have been closed and others run short handed or on short time.

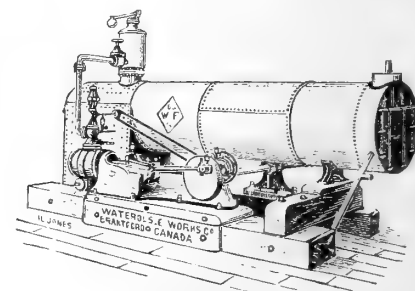

Friction Grip Pulleys.

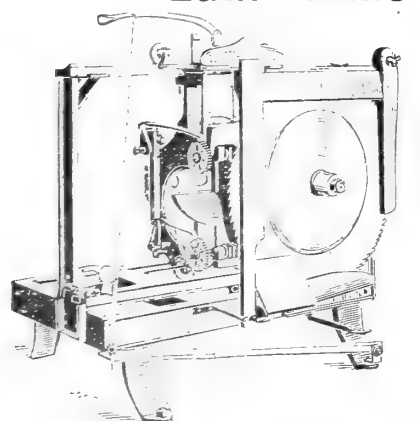

Several Sizes Combined **PLANERS.**

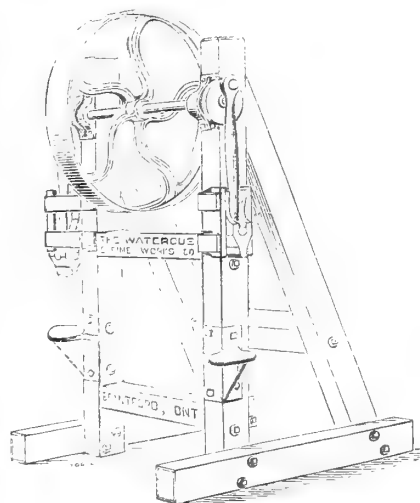

**WOODYARD OUTFITS.**

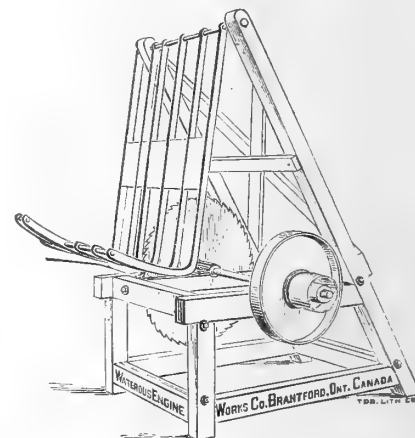

**Ewart Link Belting.**  
The Great Conveying Medium.

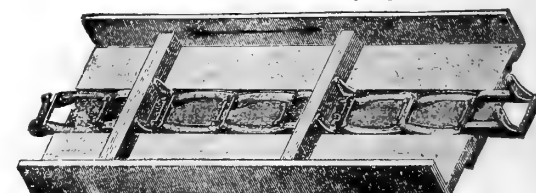
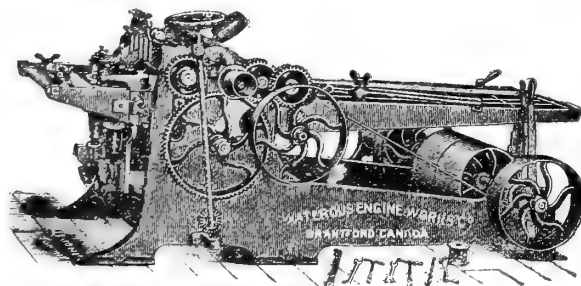
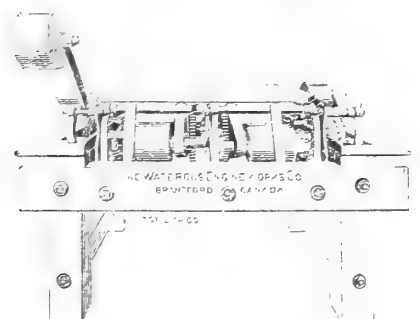

# WATEROUS ENGINE WORKS CO., Brantford, CANADA.



# PETRIE'S MACHINERY DEPOT.

Special Bargains  
this month.

## ANNOUNCEMENT.

HERE'S A CHANCE—And such a chance as comes but once in a lifetime. Having erected a large warehouse at Toronto, with a view of centralizing my business interests, I will sell for the next two or three months the stock of machinery and tools now stowed in my Brantford depot at reduced prices, in order to save cost of reshipment. Manufacturers and others who contemplate the purchase of machinery of any description whatsoever will find it greatly to their advantage to communicate with me without delay. The following list comprises only a very small portion of my stock:—

**NEW MACHINE TOOLS**—of Bertram & Sons' build—lathes, sharpeners, planes, drills, milling machines, bolt cutters, gear cutters, steam hammers, punch and shears, bending rolls, etc., etc.

**NO. 6 steel double exhaust fan**—Detroit Blower Co. make.

**SEVERAL** small size fans and blowers.

**ENGINES**—horizontal—following size cylinders—10x12, pair 5x7, 6x12, 8x12, 8½x14, 8x16, 8½x14, 6x12, 6½x12, 5x10, 5½x14, 4½x7, 3x6½, 3½x1½, 2x3½, 2½x5.

**UPRIGHT ENGINES** from 3 to 15 horse-power—full particulars on application.

**PORTABLE ENGINES** on wheels and skids from 3 to 20 horse-power.

**MARINE ENGINES** and boilers—3 to 15 horse-power.

**NEW steam yacht**—60 feet long and 9 feet beam. Send for full particulars.

**OSCILLATING ENGINE**—4½ x 8 inch—Beckett builder.

**ROTARY engines**—several sizes and makes.

**FINE** 100 horse-power boiler to build in brick—other sizes down to 2 horse-power.

**ONE** steam-heating plant—with radiators, etc. Full description on application.

**CONDENSER**—Watrous make—suitable for engine 100 horse-power.

**LARGE** stock feed water pumps, heaters, injectors, and engine governors—new and second-hand large stock.

**STEAM** pumps—several sizes and by different makers—also new of every size.

**HAND** fire engine—Seneca Falls build—a special bargain offered in this.

**FOUR** second-hand saw mills at very low price—one new 3-block mill, "Eclipse" make.

**LARGE** lot of lumber and log cars, drag saws, bull wheel rigs, edgers, butting saw rigs, and other saw mill requisites.

**18** SHINGLE mills and jointers by different makers.

**TWO** Watrous self-feed lathe mills, and one bolter.

**TWO** stone cutters, 2-foot stone jointers, Greenwood bolter and equalizing saws.

**BAND SAWS**—36 inch wheel—also several small sizes, both new and second-hand.

**6** JIG or scroll saws—from \$15 up.

**PLANERS** and matchers, surface planers, pony planers, buzz planers, etc.; large stock.

**MOULDERS**, shapers, tenoning machines, mortisers, boring machines, saw tables, blind machines, wood lathes, etc., in great variety.

**CIRCULAR** saws—from 72-inch down—saw arbours, a large assortment.

**LEATHER** and rubber belting, hose, lace leather, belt fasteners, etc.

**LARGE** lot of pulleys, fly-wheels, hangers, boxes, shafting, gearing, etc.

**WATER-WHEELS**—from 60-inch down to 12-inch diameter.

**GRIST** MILL machinery, "BUHR" stones, chopping mills, corn and cob mills, feed mills, smutters, centrifugal reels, elevators, stone dressers, etc.

FULL description in detail will be sent of any machine in above list, on application. Address H. W. PETRIE, adjoining Union station Toronto.



It is with a considerable degree of satisfaction that I can now announce to my extensive circle of patrons and the public generally that a few weeks hence I will have finished one of the most complete warehouses for my line of trade in the Dominion. Realizing to the fullest extent the present and future demands of the trade, I am sparing neither trouble nor expense in fitting up a place of business that will meet all requirements. With a substantial four-story building, having an aggregate floor space of 20,000 square feet, fitted with French plate front on main floor and equally well lighted on every flat, equipped with two of the most approved steam elevators, for passengers and freight, the latter having a lifting capacity of 12,000 pounds, heated by steam throughout and lighted by electricity, with vaults of latest design, while the offices are finished with a degree of elegance, more suggestive perhaps than any department of the solidity of the business I am doing. With all these advantages, I can, with confidence, claim an establishment which will be modern right up to date and well calculated to meet the requirements of many years to come. Nor will my stock fall short of my equipment. I shall make it a fixed rule that no customer entering my warehouse in search of any article whatever in the machinery or supply line, whether it be a complete saw-mill rig or a steam guage, a fully equipped planing mill, or a belt lace; in fact anything that is made and can be procured will be placed at the disposal of my customers. I can also with satisfaction look back over the events that have led up to the present development. Nearly 15 years ago I commenced business on a limited scale in the busy and prosperous little city of Brantford, and year by year I have seen my field of operation spreading, until I now ship goods to the farthest limits of this broad Dominion, and none but the best facilities, such as are afforded by the leading city of Canada, will meet the demands of my trade. Hence my removal to Toronto, where not only will I have superior advantages for advancing my business interests, but I am placing myself within easy reach of customers at all points; in fact with Toronto's railway facilities I am now in touch with all Canada. I wish particularly to impress on the public my location which has been selected rather with a view to the convenience of my customers than my own special accommodation. I am only 40 yards from the Union station, and have arranged for a broad plank walk from the centre arch-way of the station building up through my premises, giving the public a short cut to Front street and the street railway lines entering there and my customers the benefit of being able to do business in my wareroom up to the very moment their train starts. Also when time is limited, one minute after leaving the train they can be within the walls of my building, which advantage I am sure will be greatly appreciated. I extend to everyone, whether intending customers or others, a cordial invitation to call and see me. I will with pleasure show them over the entire building, with its many floors well filled with the productions of manufacturers from all over Canada and many points in the United States, while in the basement will be seen our work shops, where we repair and refit whatever stands in need of the machinists craft. Come and feel welcome to Canada's most complete machinery depot. Yours very truly,

W. H. PETRIE.

TORONTO AND BRANTFORD.

**H. W. PETRIE** PROPRIETOR 141 TO 145 FRONT ST. WEST. **TORONTO, ONT.**



GEO. HASTINGS.

JOHN GRAY.

H. HANCOCK.

# GEO. HASTINGS & CO.

**Lumber Merchants**

TRUST BUILDING CHAMBERS,  
Cor. Yonge and Colborne Streets.

TORONTO.

All Kinds of Pine and Hardwood Lumber.

BILL STUFF CUT TO ORDER A SPECIALTY.

# TORONTO HARDWOOD LUMBER CO.

Wholesale Dealers and Shippers in all kinds of



## HARDWOOD \* LUMBER

83 Front Street West, Corner Lorne Street, - TORONTO.

OFFICES Hamilton, Toronto Windsor	TELEPHONE No. 1046	MILLS Gravenhurst, Huntsville Katrine.
---	-----------------------	--

# ROBERT THOMSON & CO.

DEALERS IN

**Pine and Hardwood**

## LUMBER \* TIMBER

Mills Operating all the year round. Correspondence Solicited.

TORONTO OFFICE  
LONDON CANADIAN CHAMBERS 103 BAY STREET,  
THOMAS MEANEY, REPRESENTIVE. **TORONTO.**

# DONOGH & OLIVER,

Wholesale Dealers in

# LUMBER

OFFICE:

Nos. 16 and 17 Imperial Bank Buildings,

WELLINGTON STREET EAST.

TORONTO, ONT.

DALTON McCARTHY, President.

J. H. EYER, Manager

# Toronto and Midland Mf'g Co.

(INCORPORATED.)

## Wholesale \* Lumber \* Dealers

AND MANUFACTURERS OF

### DRESSED LUMBER, FLOORING

Ceiling, Sheeting, Siding, Shelving, Mouldings of all Descriptions.

Office and Yard:

FOOT OF SPADINA AVE., - TORONTO.

Planing Mills: MIDLAND, ONT.

# PORTER, ROBERTSON & CO.

STOCKS  
STRIPS  
SIDINGS  
BILLSTUFF

WHOLESALE

# LUMBER

DEALERS

HARDWOODS  
HEMLOCK  
SHINGLES  
LATH, ETC.

Millichamp's Buildings,

35 \* Adelaide \* Street \* East,  
TORONTO.

YARD: NORTHERN DOCK, FOOT OF BATHURST STREET.

Established 1849.

Incorporated 1884.

# Detroit Saw Works

MANUFACTURERS OF

## Circular, Gang, Mulay, Drag and Cross-Cut Saws.

MOLDING AND PLANING KNIVES,



We use nothing but W. I. & Sons' English Steel in our saws and the name speaks for itself.

French Band Saws, Emery Wheels and General Mill Supplies.

66, 68, 70 and 72 Fort St. East, DETROIT, MICH.



C. C. CLEVELAND. G. F. CLEVELAND.

**J. L. GOODHUE & CO.,**  
MANUFACTURERS OF  
**Leather Belting**  
AND  
**Lace Leather.**  
DANVILLE - - QUEBEC.

One of the greatest chances in America  
For a Profitable Wholesale Wood-working Industry. One of the best located plants in Tonawanda may be leased, covering seven hundred feet docked water front on the Harbor; with ground five hundred feet in depth; large factory building, two hundred by one hundred and twenty five, with basement; brick boiler and fuel rooms detached, suitable for sash, doors, blinds, boxes, and custom planing combined. Tonawanda although carrying three hundred millions of lumber in stock has yet no large industry such as proposed. Will sell or lease for term of years. Moderate rent, cheap labor, low taxes, lowest insurance.  
**SMITH, FASSETT & CO., Tonawanda, N. Y.**

RAILROAD, BANK & OFFICE  
**DESKS**  
TEES & CO.,  
300 ST. JAMES STREET, MONTREAL.

**STORAGE OF LUMBER.**  
We are prepared to receive any quantity of Lumber for storage. Freight and money will be advanced on same. Also, Warehouse Receipts issued, which can be hypothecated to banks and others. Storage charges easy. For further particulars apply to  
**W. LEAK & CO.**  
Lumber, Coal and Wood.  
DUNDAS STREET, - - TORONTO.

**GOODDAY, BENSON & CO**  
QUEBEC, P. Q.  
**General Lumber & Timber Merchants.**  
Correspondence is solicited from parties having choice stocks of Hardwood and Pine to offer, either in the log or in sawn lumber.

**JOHN BERTRAM & SONS,**  
CANADA TOOL WORKS  
DUNDAS, ONTARIO.  
MANUFACTURERS OF  
**WOOD-WORKING MACHINERY**  
MACHINE TOOLS, ETC.  
Write for Prices and Catalogues

**Packing Cases in Shooks.**  
Any Saw mill in Canada able to undertake large orders for Case Boards is requested to communicate with  
**W. & C. PANTIN**  
147 Upper Thames Street,  
LONDON, - - - - - ENC.

**GEO. CORMACK**  
Wholesale and Retail Dealer in  
*All kinds of LUMBER.*  
Lumber Shipped to all parts by Rail or Vessel.  
WHITBY, - - - - - ONTARIO

**COPPERINE** The Millwrights and Engineers Safeguard.  
Engineers'  Safeguard.  
No Hot Boxes. Stands any weight or motion. Best and cheapest metal known for Machinery Journal Bearings. Reliable Machinists use no other. To be had at every enterprising Hardware store in the Dominion.  
*ALONZO W. SPOONER, Patentee and Manufacturer, PORT HOPE, ONT*

**A. T. ANDERSON & CO.,**  
CONTRACTORS FOR  
**ELECTRICAL AND GENERAL MACHINERY.**  
Complete instalations of team and Hydraulic Power, Electric Light and Power Plants, Wiring and Construction for Arc and Incandescent Lighting. Agents for the celebrated "C. & C." Electric Motors.  
75 Adelaide Street East,  
Toronto, Ont., Canada.  
Estimates furnished and every information cheerfully given to intending purchasers.  
N. B.—Only first-class work on which a full guarantee will be given.

**THE RATHBUN COMPANY,**  
DESERONTO, - - ONTARIO,  
MANUFACTURERS OF  
**Doors, Sash, Blinds, Stairs**  
AND ALL KINDS OF WOODEN HOUSE FINISHING MATERIALS.  
CEDAR OIL FOR PURGING BOILERS.  
CORRESPONDENCE SOLICITED

**THE MONARCH BOILER (PATENTED) AND HERCULES ENGINE.**  
**A. ROBB & SONS** CELEBRATED ROTARY SAW MILL  
  
Guaranteed to Saw Lumber Perfectly Smooth and Even in thickness.  
Portable from 6 to 70 horse power. Surpass portable steam power heretofore produced for strength, durability, compactness, and the ease with which they can be moved.  
The 70 horse power can be taken over the roughest roads, or into the forest, and set up as easily and quickly as an ordinary 20 horse power portable engine, and as firm as a brick-set stationary engine. Engines and boilers of every size and description. Rotary Saw Mills, Shingle and Lath machines, Law Grinders, Planers, etc. Mill machinery and supplies of every description. Every boiler insured against explosion by the Boiler Insurance & Inspection Co. of Canada. Write for circulars.  
A. ROBB & SONS, Amherst Foundry and Amherst, N.S. Machine works.  
ESTABLISHED OVER 40 YEARS.

**LUMBER TRUCK \* WHEELS.**  
\*\*\*\*\*  
**The Montreal \* Car Wheel Co.**  
MANUFACTURERS OF  
CHARCOAL IRON CHILLED

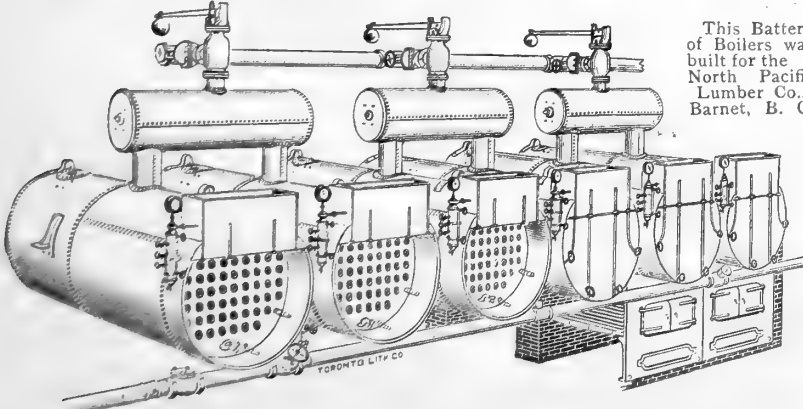
**Boiler and Burner Work**  
  
This Battery of Boilers was built for the North Pacific Lumber Co., Barnet, B. C.  
Send for Estimates  
**Waterous Engine Works Co., Brantford, Canada**

**Menasha Hickory Pulleys**  
We make the only hardwood bent rim spoke arm split pulley, only small split pulley, only wooden hangers in the market. Send for discounts & circulars.  
Menasha Wood Split Pulley Co.  
MENASHA, WISCONSIN.  
**T. SHORTISS,**  
DEALER IN  
**PINE & MINERAL LANDS**  
9 Toronto Street,  
TORONTO, - - - - - ONT.  
CORRESPONDENCE SOLICITED.

**RAILROAD WHEELS**  
Offices: New York Life Insurance Building, Montreal.  
Works: Lachine, Quebec.  
\*\*\*\*\*  
WE make a Specialty of Wheels suitable for the requirements of Lumbermen and Street Car Service, and can supply them Bored, Finished and Balanced.  
CORRESPONDENCE SOLICITED

TAPER TOOTH.



TELEPHONE 5120.

**Burns & Thomas**

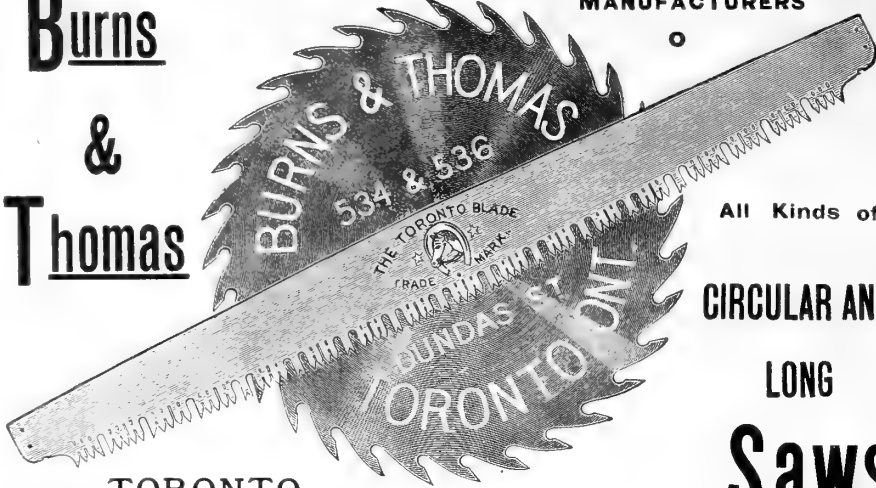

MANUFACTURERS

TORONTO.

LANCE TOOTH.



WORKS AT PARKDALE.

All Kinds of  
CIRCULAR AND  
LONG  
**Saws**

# The Dodge Patent System of ROPE TRANSMISSION OF POWER.

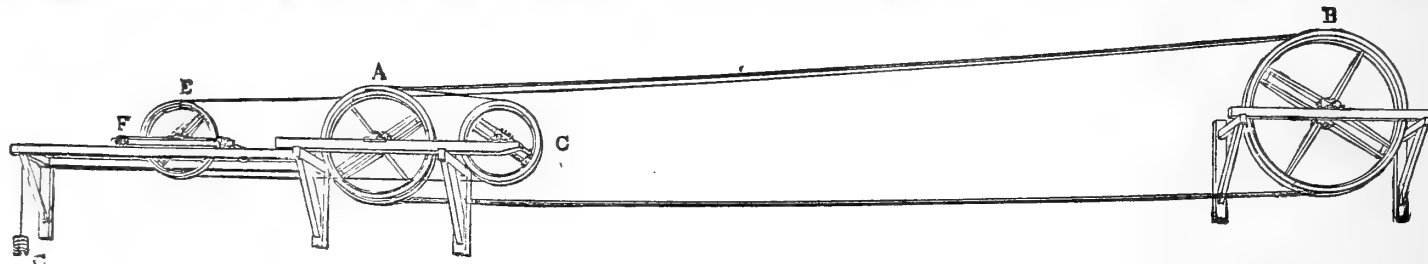

The above cut represents a simple Drive from one shaft to another, and can be applied in any case, or to any distance, in or out of doors. The ordinary space between centres being limited, to say, 100 feet, after which additional Carriers can be added to any distance. For full information and particulars, apply to

## \* Dodge Wood Split Pulley Co. \*

City Office, 83 King St., W.

TORONTO.

TELEPHONE 2080.

## THE "LEADER"

The Finest Tempered, Fastest Cutting and Best Saw made on the Continent.



Manufactured of Triple Refined Silver Steel, Rolled specially for us from Superior Ingots.

THE KING OF CROSS-CUT SAWS.

R. H. SMITH COMPANY, LTD., ST. CATHARINES, ONT.

Sole Manufacturers

# THE CANADA LUMBERMAN.

VOLUME XII }  
NUMBER 2 }

TORONTO, ONT., FEBRUARY, 1891.

TERMS \$1.00 PER YEAR.  
7 SINGLE COPIES, 10 CENTS.

## THE CANADA LUMBERMAN

PUBLISHED MONTHLY BY

ARTHUR G. MORTIMER,

OFFICE:

75 CANADA LIFE ASSURANCE BUILDING,  
TORONTO, ONTARIO.

### TERMS OF SUBSCRIPTION:

One Copy one Year, in Advance, - - - - \$1.00  
One Copy six months, in Advance, - - - - 50

Advertising Rates Furnished on Application.

THE CANADA LUMBERMAN is published in the interest of the lumber trade and of allied industries throughout the Dominion being the only representative in Canada of this foremost branch of the commerce of this country. It aims at giving full and timely information on all subjects touching these interests, discussing these topics editorially and inviting free discussion of them by others.

Especial pains are taken to secure the latest and most trustworthy market quotations from various points throughout the world so as to afford to the trade in Canada information upon which it can rely in its operations.

Special correspondents in localities of importance present accurate report not only of prices and the condition of the market but, also of other matters specially interesting to our readers. But correspondence is not only welcome but is invited from all who have any information to communicate or subjects to discuss relating to the trade or in any way effecting it. Even when we may not be able to agree with the writers we will give them a fair opportunity for free discussion as the best means of eliciting the truth. Any items of interest are particularly requested for even if not of great importance individually they contribute to a fund of information from which general results are obtained.

Advertisers will receive careful attention and liberal treatment. We need not point out that for many the CANADA LUMBERMAN with its special class of readers is not only an exceptionally good medium for securing publicity but is indispensable for those who would bring themselves before the notice of that class. Special attention is directed to "WANTED" and "FOR SALE" advertisements which will be inserted in a conspicuous position at the uniform price of 15 cents per line for each insertion. Announcements of this character will be subject to a discount of 25 per cent. if ordered for three successive issues or longer.

Subscribers will find the small amount they pay for the CANADA LUMBERMAN quite insignificant as compared with its value to them. There is not an individual in the trade or specially interested in it, who should not be on our list thus obtaining the present benefit and aiding and encouraging us to render it even more complete.

### TO VISITING LUMBERMEN.

LUMBERMEN visiting Toronto are invited to use the office of the LUMBERMAN as their own. We shall take pleasure in supplying them with every convenience for receiving and answering their correspondence, and hold ourselves at their service in any other way that they may desire.

THE E. B. Eddy Manufacturing Company, limited, will apply to the Parliament of Canada at its next session for an act empowering said company to reduce the capital stock to three hundred thousand dollars and otherwise to amend its act of incorporation.

A TRACK cutter for logging roads was patented in Nov., 1890 by Mr. E. R. Week, of Stevens Point, Wis. The device is intended to true up the bed of the logging road, and consists of two bob sleds carrying a frame, having their runners arranged to give a long sled base; a pair of adjustable cutters are supported by the frame between the sleds, in line with, but separate from the runners.

AT the preliminary trial of the prisoners arrested for robbing the stores of the Muskoka Mill & Lumber Co. last Nov., no evidence was produced sufficient to connect the Perraults with the burglary. Geo. Perrault was sentenced to four months in jail with hard labor for carrying a revolver, and disorderly conduct in Nov. last. "Jim" Landrigan, who from the evidence undoubtedly committed the crime, was sent up for trial, bail being refused.

It is argued that oak will continue as the fashionable wood for furniture and house finish because there is nothing to take its place. There is a good deal in that. But there are other and better reasons why it will continue in favor. Its endurance, richness and beauty will always keep it in high favor for certain uses. It would certainly have been just as popular years ago as it is now, had we known as well how to bring out its beauty and richness.

A SHAFT coupling was patented in Canada last fall by Mr. David Boorman, of Altoona, Penn. It is a device whereby a pair of shafts may be readily tightened, loosened, coupled or uncoupled, and consists of a collar having key seats or recesses therein and an opening through it to receive the ends of the shafts to be coupled; wedged shaped keys adapted to fit in the recesses in the ends of the shafts and the collar secured by nuts securely couple the two ends together.

STATEMENTS prepared by Government Statistician Johnson go to show that while Canada only sent \$1,100,000 worth of lumber and other products of the forest last year to the West Indies and South Central America the United States sent \$7,000,000. There is a big market for lumber to the south of us, outside of the United States, and to that market it would be well if our lumbermen would direct their attention as well as to the West Indies.

THE experiment of transporting lumber on barges instead of by raft, is to be tried on a large scale on the Mississippi river next season by Capt. Sam Vansant, a well known raftsman of Winona, Minn. It is claimed that it can be moved cheaper in this way than by the time honored method of rafting, as much will be saved in handling, aside from the advantage of having the lumber kept dry while on the way. It is computed that 2,500,000 feet can be transported in a tow of eight barges and that the saving on this quantity over the old method would be \$800.

THE *Australasian and South American*, a trade paper devoted to the interests of our foreign trade, thinks that the governments of the United States and Canada should unite in some course of action with regard to the Leary rafts. As it is, it says, these immense floating islands of timber creep along the coast in the track of vessels going in all directions over the same track. The greatest danger is incurred, according to the same authority, in the liability of the sections of the raft to drift derelict about the ocean, after abandonment in a storm; or, in the shape of scattered logs, dispersed over a wide area, they may prove a constant menace to shipping.

APPLICATION will be made to the Parliament of the Dominion of Canada, at the next session thereof, for an act to incorporate a company to be called "The Pembroke Lumber Company," with power to carry on the business of manufacturers of timber, saw logs and sawed lumber, and the buying, selling, mortgaging, or pledging the same and dealing therein, and to become parties to promissory notes, drafts and bills of exchange, and to borrow money, and to carry on the business of wharfingers and warehousemen, and to acquire and hold lands and Crown timber limits for the purpose of said business in Canada; and to buy and sell, mortgage or pledge the same, and to do all other acts incident to said business in Canada or elsewhere.

A MAHOGANY tree lately cut in Honduras made three logs, which were sold in Europe and brought \$11,000. The mahogany tree ranges from one to seven feet in diameter, is often sixty feet to the first branches and frequently exceeds ninety feet in height. The Honduras mahogany comes to market in logs from two to four feet square and twelve to fourteen feet long, planks sometimes being obtained that are seven feet wide. The weight of a cubic foot of mahogany varies from thirty-five to fifty-three pounds. As compared with oak, which is called 100 per cent., the strength of mahogany is 67 and 96, its stiffness is from 73 to 93, and its toughness from 61 to 99 per cent. The government engineer of Honduras estimates the total value of the trees, such as are regarded fit to be cut, at \$200,000,000 while the smaller trees, not ready to cut, are also worth a large amount.

SUB-CLAUSE c. of Section 2 of the Timber Regulations approved by the Order-in-Council of the 17th day of September, 1889, establishing regulations affecting Timber on Dominion Lands, chapter 98 of the consolidated Orders-in-Council of Canada, has been amended and now reads: Licensees shall have the option of either paying the royalty of five per cent. therein specified, on the value of the lumber in the log, or at the period at which the lumber, when manufactured is sold; and that if the dues are paid at the former period, the royalty shall be on the average price received for lumber during the three months next previous to the date upon which the dues are paid. Section 20 of the Regulations in question, which provides for a drawback or rebate of the dues paid upon timber which has been exported beyond the limits of Canada, has been repealed.

SAMPLES consisting of various kinds of maple, alder, cottonwood, cedar, spruce and fir were sent by the Brunette Sawmill Co., New Westminster, B. C., to Mr. J. W. McRae, of the firm of Murphy & McRae, forwarders. This is the firm who recently shipped 17 car loads of fir to Toronto, the freight on which was \$4,000. They are cutting the timber for the new vessel being built for the Hudson Bay Co.—one stick is 82 feet long and another is 5x18—and filling an order for 150,000 feet dimension stuff for a cannery. The invention in the shape of endless chains alternated with stationary timbers sloping to the lower part of the mill, for the safe transfer of trimmed lumber is working very satisfactorily. The lumber is pushed on to a system of hooks attached to the chains after coming from the saws, and is gently and continuously deposited to where it is transferred to the waiting trucks by the men in attendance. The Brunette Mills were the first in the province to take advantage of this way of carefully handling the lighter class of lumber from the upper floors of the mill to the ground.

MR. J. W. TODD, of the firm of Watson & Todd, lumber merchants, of Liverpool, Eng., was in Ottawa towards the end of last month and on being questioned by a reporter from the *Ottawa Journal* at to the British prospects said: "The probability is, that the English market will improve as the new year advances, and this is a pretty reliable prediction if only from the fact that it cannot possibly grow worse." Speaking of the past year's trade, Mr. Todd said it was a very calamitous year, being one of almost constant disappointment and loss. The importations had been excessive and were followed by hampered financial stress, and the market became to a certain extent de-



moralized. There were other reasons for the falling off in the timber trade. Every market is, of course, regulated by the law of supply and demand, and though their operation may be retarded or temporarily rendered ineffective, these laws must ultimately assert themselves and they have done so in the English market. The supply has been greater than the demand, and if the year just closed has suffered most it was, in his opinion, because the climax had been reached.

THE failure of the J. E. Potts Salt and Lumber Co., of Potts, Mich., reported in our January issue, has proven a calamity. Over 1,000 men were thrown out of employment. The village is dead. Twenty two new locomotives, over four hundred cars and sixty eight teams of horses are idle. The mill cut during the season 98,399,466 feet of lumber, said to be the largest season's output of any mill in the world. To saw this it ran continuously 207 days and 201 nights. Enough logs are at the mill or in the limits to keep the mill running for a year, and the company's own railroad runs up to the tract of land on which there stands uncut over 350,000,000 feet of pine.

WE received an invitation from the Buffalo Lumber Exchange to attend a dinner on the 31st ult. at the Genesee, Buffalo. It was our intention to be present at the gathering, and we regret that other business engagements prevented us from partaking of the hospitality of our Buffalo friends. We wish the guests an enjoyable evening, even if they have to protract the time into "the wee sma oors." They can do this in Buffalo without being molested. In Toronto "the good" lumbermen enjoying themselves early on Sunday morning would have to extract comfort from the soft side of a pine plank in a cooler.

IT is a peculiar fact that forest trees do not, as a rule, succeed their kinds. In several parts of Western Ontario where ridges or plateaus of pine once flourished there are young forests of maple, beech and other hard wood. There is a natural law governing the succession of timber. Hemlock is succeeded by poplar, particularly in swales, oak by hickory, ash and beech. The rule would seem to be that other timber than the original takes its place very likely from the fact that wood, like grain, flourished for a period until they have robbed the soil of the elements necessary for their existence, and left untouched the compounds necessary to feed some other kind.

OUR list of accidents and fatalities is unusually long this month. The occupation of a chopper, hewer or logger, is very hazardous, and when injured, the distance to cover before reaching medical assistance frequently puts the unfortunate beyond human aid. Shanty men go into the woods in gangs in the fall; they are deprived of the most of creature comforts; exposed to inclement weather from daylight to dark, and bunk in a log shelter at night, far from palatial. If the owner of the limit, or the foreman of any shanty, will send the addresses and the name of the nearest post office where mail matter can be delivered the LUMBERMAN will be glad to send copies of its issue free of charge, and if any foreman finds that his employees take an interest in the news items and the various topics discussed in the journal we will mail him some of our exchanges.

MR. SAMUEL PLIMSOLL, that gentleman with a "mission," the sailor's friend, is after the scalp of the deal and sawn lumber shipper of eastern Canada. As soon as he has been presented with an address and a gold medal by the "Bovines" for whom he is to provide Pullman and Wagner stalls, his attention will be directed to vessels employed in the deal and sawn lumber trade. Somebody has told him, or he has found out by accident or enquiry, that many vessels are employed in the trade positively useless to carry any other cargo and unfit even to carry deals; that the deck-loads are carelessly piled, and so high that in foul weather limbs and life are endangered: that vessels flounder about in mid-ocean uncontrolled by

sail or helm from being greatly overloaded and that many partially controlled are weeks behind on their trip. The old gentleman, if he gets an idea into his cranium, pushes it with bull-dog tenacity, takes little notice of the opinions of others and ferrets around until he snuffs out by his own efforts the truth or the falsehood of the reports. If there is anything in the reports, —look out for squalls, Eastern shipper

THE lumber section of the Toronto, Ont., Board of Trade held its annual meeting January 22nd, and elected the following committees: Executive, Joseph Oliver, (chairman), A. A. Scott, William Leak, George Gall, James Tennant. Arbitration, A. R. Christie, J. B. Christie, John Donogh. Inspection, A. R. Riches, George Gall, James Tennant. Edgar A. Willis was re-elected secretary and treasurer. The main item of business was the question of representation on the Council of the Board of Trade. Mr. John Donogh of the wholesale lumber firm of Donogh & Oliver, received the appointment, no opposition being offered. At the annual meeting of the Board of Trade held the same day Mr. Donogh's name was added to the Council as the representative of the lumber section. In the selection of the appointee the lumbermen, who for the first time will have a voice in the deliberations of the Council, chose one of the strongest men from amongst their membership and their interest cannot but be safe in Mr. Donogh's hands.

THE different lumbermen's organizations have been busy during the past month holding their annual, bi-annual, or quarterly meetings. The first to meet at Toledo, Ohio, on the 19th ult., was the Union Association of Retail Lumber Dealers of Ohio. The Michigan Retail Lumber Dealers met at Kalamazoo; the Illinois Retail Dealers at Springfield, Ill.; and the Wholesale Sash, Door and Blind Manufacturing Association of the Northwest met at Chicago on the 21st ult. The Chicago Wholesale Dealers met in their rooms in the Chamber of Commerce and issued a new schedule of prices. The old price list of Oct. 22nd, 1890, was revised and in the new list adopted prices were raised 50c. to \$2 per M on everything except pickets and battens. The Kansas and Missouri Lumber Dealers met on the 27th ult., at Kansas City, and the Northwestern Lumbermen's Association at Minneapolis on the 28th. The present month, February, the following Associations meet:—The Teche and Gulf Coast Cypress Lumber and Shingle Association, New Iberia, La., Monday, February 2. The Georgia Sawmill Association, Atlanta, Ga., February 9. The Southern Cypress Lumber and Shingle Association, New Orleans, La., February 11. The Southern Lumber Manufacturers' Association, at Memphis, Tenn., February 18.

A BILL has been brought before the Imperial Parliament which proposes to amend the law respecting timber deck loads in winter. The attention of the Minister of Marine was directed to the fact that the correspondence relating to deck loads of lumber, *re* the said bill, was not yet complete. A copy of Mr. Samuel Plimsoll's letters on the subject was brought to Mr. Tupper's notice, and also Lord Knutsford's despatch to the Governor General, requesting him to state if the Canadian Government was prepared to initiate legislation of the same nature as the Imperial House of Commons. In the opinion of Mr. Plimsoll Canada should prohibit the exportation of deck loads of timber in winter. The letter of Mr. Plimsoll, referred to in the despatch from the Colonial Office, stated that while some Canadian ship owners might press for retaining the present three feet limit of deck loads, they did not represent Canada in this respect, but that the Dominion as a whole co-operated with those in England who were agitating to prohibit the carrying of timber on deck in winter. In support of his statement, Mr. Plimsoll instanced alleged facts to show the great danger to shipping and to sailors by allowing winter deck loads. "These statements," said Mr. Tupper, "were most important, for, if true, the legislation asked for ought to be passed. My report to council showed that so far as these statements were made applicable to Canada they had no foundation in

fact; in other words, that Canadian shipping had produced no such record as Mr. Plimsoll alleged. When Mr. Plimsoll was in Canada he admitted that he had not looked particularly into the statistics of Canada shipping and the deck load law; that his statistics were based on the general tonnage of vessels sailing from different ports and carrying winter deck loads. Mr. Plimsoll further acknowledged that he did not apply his statements directly to Canada; that, in fact, he had not the Dominion in his mind at the time, but he supposed they applied to Canada, as to other portions of the empire."

WE had almost concluded that the crass ignorance existing some years ago in the mother country regarding Canada had died a natural death. We know for a fact that we are no longer looked upon as a species of white savage clad in furs for six months prowling round after wild animals, or else being drawn over six feet of snow by a dog team, yet we were unprepared for the "Gulliver" we stumbled across in the London, England *Timber Trades Journal*. A letter appears in that publication from a Liverpool timber merchant who states regarding the export of deals from Halifax, N. S., and St. John, N. B., during the winter months "That he is aware those ports are open so far as the water is concerned, but that the deals are mostly away from the port and are frozen so hard that it is impossible to ship them; and it is very exceptional to hear of a cargo being shipped from St. John." The *Timber Trades Journal* comes to the rescue of the befogged merchant with the following choice tit-bit of information:

"We always thought that the reason for the supply ceasing from countries far north was not that the commodities were frozen, but that the ships could not get away en voyage when the goods were put on board in consequence of the ports being icebound. Admitted that St. John is open on the 1st of January, we should like the Liverpool firm to give a fuller explanation of the difficulties that lie in the way of loading a steamer that is ready to receive cargo on the date and at the place mentioned. We are quite aware there are seasons when the cold is so intense as almost to stop labor of any kind, but these are exceptional, and when they do happen St. John is closed by ice and navigation is stopped."

The St. John *Evening Gazette* supplies these statistics. Winter months 1883-84, 44 vessels, 9 of which were steamers left St. John for Great Britain with cargoes of deals. Winter months of 1887-88, 33 vessels cleared, 10 of which were steamers. Winter months of 1888-89, 47 vessels including 9 steamers sailed from that port. On Christmas day of 1890 there were five large vessels in the port of St. John loading with deals for France and one for South America, four other such vessels being then expected to arrive there to load deals for Europe, two of them steamers.

The *Gazette* closes its remarks on the question by giving the *Timber Trades Journal* so much knowledge on the St. John timber trade that forever it should be an authority on that particular section of Canada. It says:—

"It is rather pitiful to find such a paper as the *Timber Trades Journal* showing such dense ignorance as to say that there are seasons when St. John is closed with ice, and navigation stopped, and gravely informing its readers that vessels sailing in the Bay of Fundy in winter are in danger of encountering huge icebergs. What sort of an atlas does the *Timber Trades Journal* consult when it describes St. John as a port "far north," the fact being that St. John is six degrees or 360 geographical miles further south than London and eight degrees or 480 geographical miles further south than Liverpool. If such absurd blunders had appeared in any other English paper but one devoted to the timber trade they might have been forgiven, but in such a journal they are to us altogether incomprehensible. Let the *Timber Trades Journal* understand once for all, and let him and all other British editors paste in their hats the following paragraph, which contains the facts of the case with regard to St. John:—The port of St. John is open all the year round; it is never obstructed by ice to the slightest degree, and there is no more difficulty in a vessel loading deals or any other cargo at St. John in mid-winter than there is in a vessel taking in a cargo at Liverpool or London."

#### TRADE NOTES.

Among the machinery lately added to Mr. Petrie's new and commodious warehouse, on Front Street West, are several planers, including a "Defiance" planer, shapers, saw tables, lathes, band saws, sandpaperers, tenoning, mitering, morticing blind, and re-sawing machine, a band saw filer and a band saw setter, amongst them being several of new pattern, all manufactured by the Cant Bros. Co., of Galt, Limited, of whose various and well known woodworking machines Mr. Petrie intends making a specialty.

TRADE REVIEW.

Toronto, Ont.

TORONTO, Jan. 31, 1891.

CAR OR CARGO LOTS.

Table listing lumber prices for Toronto, Ontario, including items like cut up and better, 1x10 & 12 dressing and better, etc.

YARD QUOTATIONS.

Table listing yard quotations for Toronto, Ontario, including mill cull boards, shipping cull boards, etc.

Hamilton, Ont.

HAMILTON, Jan. 31, 1891.

Table listing lumber prices for Hamilton, Ontario, including mill cull boards and scantlings, shipping cull boards, etc.

Ottawa, Ont.

OTTAWA, Jan. 31, 1891.

Table listing lumber prices for Ottawa, Ontario, including pine, 1st qual., 2nd, etc.

Montreal, Que.

MONTREAL, Jan. 31, 1891.

Table listing lumber prices for Montreal, Quebec, including pine, 1st quality, 2nd, etc.

St. John, N. B.

ST. JOHN, Jan. 31, 1891.

Table listing lumber prices for St. John, New Brunswick, including spruce deals, pine, etc.

Vancouver and New Westminster, B.C.

NEW WESTMINSTER, Jan. 31, 1891.

Table listing lumber prices for Vancouver and New Westminster, British Columbia, including car load and ship rates, bridge and wharf plank, etc.

Albany, N. Y.

ALBANY, N. Y., Jan. 31, 1891.

Table listing lumber prices for Albany, New York, including boards, joists, pine, etc.

Buffalo and Tonawanda, N. Y.

BUFFALO, Jan. 31, 1891.

Table listing lumber prices for Buffalo and Tonawanda, New York, including clear, 1 in. & clear, etc.

Saginaw, Mich.

EAST SAGINAW, Jan. 31, 1891.

Table listing lumber prices for Saginaw, Michigan, including cargo lots, yard quotations, etc.

New York City

NEW YORK, Jan. 31, 1891.

Table listing lumber prices for New York City, including back walnut, poplar or white wood, etc.

Boston, Mass.

BOSTON, Jan. 31, 1891.

Table listing lumber prices for Boston, Massachusetts, including western pine, eastern pine, etc.

Table listing lumber prices for Boston, Massachusetts, including spruce by cargo, shingles, etc.

## GIANTS OF THE FOREST.

WE publish a letter from Mr. G. C. Hinton, of the Royal City Saw and Planing Mills, New Westminster, B. C.:

Mr. Hinton was raised in Ottawa and from experience is fitted to make a just comparison between eastern Canada's timber and the Pacific coast's.

NEW WESTMINSTER, B. C., Dec. 20.—The lumber industry of British Columbia is advancing so rapidly that it is only a matter of a few years when the Douglas fir and cedar will be introduced into the principal commercial centres of the world.

Already the mills of this province have the sawing capacity taxed to its utmost in supplying the rapidly and ever increasing demand for the celebrated Douglas fir, which is exported to Australia, China and South America. The great superiority of the fir in building structures where strength is required is simply proven by the admiralty test which places this wood second only to oak, where immense strength or breaking strain are desired, and in some places where lasting and weatherproof qualities are required, fully on a par with that valuable wood. It will thus be seen that the fir will naturally command an extensive market, and owing to the inexhaustible supply to be procured and its being much cheaper than hardwood, it will supplant hardwood in many industries where that is at present being used. The fir is already used extensively by the leading railway and car builders of both the United States and Canada for the construction of freight and passenger coaches and in the erection of pier, wharf and bridge structures. Its great length commends it to ship builders for masts, deck-planking and general work. It has to some extent been used by both the British and American governments in the construction of vessels for their service.

## THE SIZE OF THE TIMBER.

A general idea may be formed of the immense size of the timber when sticks upwards of 100 feet in length and from 18 to 24 inches square are frequently seen around the saw mills. Probably the two largest sticks ever transported through Canada by rail were the two sawn on Burrard Inlet and used on the Montreal harbor improvements last season. The sticks were alike, 60 feet in length and 3 feet square, containing 6,480 feet, b.m. each, their combined weight being a fraction over 25½ tons.

Owing to the necessarily high cost of transporting such huge timber across the continent by rail it is expected that cargoes from here for the Eastern States and Canada will go by vessel via Cape Horn considerably cheaper, and we have on record an instance in which this way of shipping was highly successful, in the case of a cargo taken from Washington Territory to the United States navy yards, on the Atlantic, during the last season.

## IMMENSE RED CEDAR.

The red cedar, which is a valuable commercial wood is noted for its immense size and not altogether unlike the far famed California redwood. Trees are frequently met with upwards of 200 feet in height and over 20 feet in diameter at the trunk. The supply is, practically speaking, unlimited. Owing to the beautiful grain and fine polish this wood is susceptible of, it is invaluable for all kinds of finish and fittings for residences and public and commercial buildings. Recently quite a demand has sprung up for sash and doors made from this wood as it is superior to any other for this class of work. We have a record of not a few shipments that have gone east as far as Nova Scotia. It is also used extensively in the building of steam launches, for which it is second to none, owing to its weight and ability to withstand decay against the sun and water.

## SPRUCE, PINE, ETC.

The spruce found in this province, while not so valuable commercially as fir and cedar, is used very extensively in the manufacture of fruit boxes and cases for the great salmon industry.

White pine is found to some extent but owing to the scarcity and the purposes for which it is used commands better prices at home than either cedar or fir does in the log. It is not, however, exported to any

great extent as it does not differ much from the eastern article of the same name.

Alder, maple, yew, cottonwood and cypress are to be found in considerable quantities in places and are principally used in all kinds of factory work, such as fancy panelling for doors, stairs, furniture and turned work, the two former having the preference owing to the superior finish they are capable of taking.

## NEW MILLS BUILDING.

The great natural advantages the province offers the lumber industry have attracted the attention of quite a few eastern lumbermen and capitalists of late years and several new mills are now under construction on Burrard Inlet and the Fraser river, which is the fresh water port of the province and possesses a fine harbor for the accommodation of the largest ships engaged in trade with foreign countries. The mills are being constructed on the most improved pattern and on a sufficiently large scale to facilitate the sawing of the gigantic timbers of these forests.

GEORGE C. HINTON.

## CALIFORNIA FORESTS.

WILLIAM S. Lyon, chief forester of the State Board of Forestry, arrived in San Francisco last month from the State nurseries near Santa Monica, Los Angeles county. "It is not generally known," said he to a *Wood and Iron* reporter, "that the common black oak used for tanning purposes, is becoming scarcer each year, and to take its place we have been looking around for a suitable tree, and have found it in the black wattle. Since we made the discovery of which tree was best adapted to the State and for the purpose wanted, the State Board has been hard at work introducing into California the black wattle from Victoria, Australia. As long ago as 1872 the University of California imported red wattle and golden wattle from South Australia, and a species known as the black wattle. This last has turned out to be a spurious tree, absolutely worthless for the purpose for which it was designed. We have at last found the genuine article, the black wattle of Victoria, and we propose to plant these seeds throughout the State as soon as possible. My forthcoming biennial report deals largely with this important subject. The report will have thirty-two full page illustrations dealing with the growing of barks for tannery purposes. The coast supply of common black oak will in time become exhausted, and the black wattle is the only tree to take its place.

Another important work we are commencing is the distribution of the cluster pine, made necessary to State interest from the fact that our pine forests do not yield terebinthine products, such as turpentine, tar, pitch and resin, in sufficient quality or quantity. The cluster pine is the best for the purpose, and it does not take a lifetime for it to yield paying returns."

## HOW CLOTHES-PINS ARE MADE.

IF there is one article that is an absolute necessity to a housekeeper it is a clothes-pin, and the following facts in regard to that useful article are interesting:

Canadian clothes-pins are made at Newmarket, Ont., Eastman, Que., and Rundhill N. B. They are usually of white ash, but we have them of beech, birch, and maple. The wood is taken to the factory in logs, and cut into lengths of thirty-one inches by circular saws. These are then cut into blocks which are reduced to sticks, then placed under another saw and reduced to clothes-pin lengths. Next the turner takes a hand at them, and from him they go to the slitting machine. They are placed in troughs by the operator, the machine picking them up and slatting them. Then they are placed in a revolving pipe drier, going thence to the polishing cylinder. Each pin passes through eight hands.

"A single plant consists of a board saw, gang splitter, gang chunker, turning lathe, drying house and polisher, and costs from \$10,000 to \$19,000. The little blocks of wood, five and one half inches long, are placed on an endless belt, which feeds the blocks automatically into the lathe. As the lathe is turned the pin is taken automatically from the spindle and placed on a turn-table and carried to a circular saw, which whittles out the

slat into a pin. It is then finished and thrown out of the turn-table by the same appliance that puts the pins on the table.

"Falling, they are caught in a basket or barrel, and are taken to the drying house to remain twelve hours or until dry. The polishing cylinder holds from twenty to forty bushels. This is run at a slow speed, about thirty turns a minute, and by simple friction and contact they become polished. They are sold to the trade at a little over \$1 a bushel, and are packed in boxes of four to the bushel. The industry is an increasing one, and almost \$50,000 worth of pins were manufactured in 1890."

## "THE SCOW BUSS UP ON LAC ST. PIERRE."

'T WAS one dark night on Lac St. Pierre,  
De wind was "blow," "blow," "blow."  
When the crew of the wood scow JULE LA PLANT  
Get scare and run below.

For de wind she's blows like hurricane.

Bimeby she's blow some more,  
Whert de scow buss up on Lac St. Pierre,  
One half mile from de shore.

De captain she's walk on de front deck,  
She's walk on de hind deck too,  
She's call de crew from up de hole,  
She call de cook, also.

De Cook he's name was Rosa,  
He's come from Moreal,  
Was chambermaid on lumber barge,  
On dat big Lachine Canal.

De wind she's blow from Nor, Eass, Wess,  
De Sou's wind she's blow too,  
When Rosa say, my God, captain,  
Whatever shall I do.

De captain she' throw the hank,  
But still dat skow she drift.  
For de crew he pass on dat shore  
Because he loose dat skiff.

De night was dark, like one black cat,  
De waves run high and fass.  
When de captain take poor Rosa,  
And lash her to the mass.

When de captain put on de life preserve  
And he jump on de Lac.  
And he say good-bye, my Rosa, dear,  
I go down for your sake.

Next morning very early,  
About half-past two, three, four,  
De captain's cook and wood scow  
Lay corpses on de shore.

For de wind he's blow like hurricane,  
Pretty soon she's blow some more,  
For dat skow buss up on Lac St. Pierre,  
One-half mile from de shore.

## MORAL.

Now all good skow sailor man's,  
Take warning by dat storm,  
And go and marry one nice French girl,  
And live on one good farm.

Den de wind she may blow like hurricane.  
And 'spose she blow some more,  
You shant be drowned on Lac St. Pierre,  
So long you stop on shore.

## TIMBER FOUR THOUSAND YEARS OLD.

PROBABLY the oldest timber in the world which has been subjected to the use of man is found in the ancient temple of Egypt, in connection with stone-work, which is known to be at least four thousand years old. This is the only wood used in the construction of the temple, and is in the form of ties, holding the end of one stone to another. When two blocks were laid in place an excavation about an inch deep was made in each block, in which one of these wooden ties, shaped like an hour-glass was driven. It is therefore very difficult to force a stone from its position. These ancient ties are made of tamarisk or shittim wood, the same as that from which the ark was constructed.

MELBOURNE, N. S. W., Australia, imported from Canada during Nov. 1889, 11,586 pieces deals and 1,079,635 feet lineal tongued and grooved flooring.



## THE NEWS.

## ONTARIO.

—Cordwood and cedar poles are Fesserton currency just now.

—There is good sleighing at Sturgeon Bay and log drawing is all the go.

—John Fraser has his new planing mill in Amherstburg in running order.

—A gang of lumbermen is at present busily engaged taking out timber at Honeywood.

—Reports from Glenfarrow state that farmers are busy hauling logs to the mills.

—Messrs. J. Moore and Abner Ball have a large saw logging contract for Mr. Hudden.

—The Holbert Grass Valley, Burk's Falls, steam saw mill is in full swing cutting shingles.

—Mr. Edmondson's saw mill at Uthoff will start in a few days and enliven things pretty well.

—Mr. McBrady's shingle mill at Washago is turning out shingles with lightning speed.

—Mr. Ainslie and Mr. Fields are cutting steadily in the woods and in their mills at Staples.

—The Waubashene box factory is running full time and doing all the work it is capable of doing.

—The Blytheswood saw mill yards are being filled with logs, advantage being taken of the snow fall.

—Bush fires were prevalent north of Deseronto during January, the reflection being plainly seen.

—Four hundred men have been engaged in cutting logs, timber, ties and posts, near Ormsby, in North Hastings.

—Mr. D. Miller's shingle mill, Washago, started again last week. This is the first in the field in this vicinity.

—McLean & Son, Wingham, are receiving on an average seventy-five sleigh loads of saw-logs per day at their mill.

—Logs are scarce in the Ashfield mill yards. Owing to lack of snow lumbering has been far from active this winter.

—Mr. John Knight, Medonte, is buying all the saw logs offered and is contracting for all that can be cut this season.

—Mr. Henry Bush, foreman for the Rathbun Co., Deseronto, is running a cordwood shanty in the McCarney swamp.

—Mr. Harry Pedwell, a prominent mill owner of Keppel, purchased from private holders, Eastnor, some 600 acres of timber lands.

—The lumber exports from the Ottawa Consular Agency for the last three months of 1890 reached \$701,301.04, a slight increase.

—The new saw mill at Gorrie will start this month and will try to cut sufficient logs to make room in the yard to give farmers a chance to unload.

—Mr. Archie McTavish, of the 7th con. Luther, is erecting a shingle mill, and expects to have it in running order about the end of January.

—Business is booming at South River. Shingle bolts and pulpwood are being piled up in all directions, owing to the scarcity of cars.

—J. R. Selkirk, W. James, of Cottam, and Mr. Biers, of Detroit, have purchased a tract of timber land in Missouri, containing 1,560 acres.

—About 500,000 feet of timber came into Edgar's Station after the slight fall of snow, in the beginning of last week, much of it for M. Barrett.

The Rathbun Company are now getting out a large number of logs at O'Neil's spur, near Stoco, an average of fifteen cars per day being shipped from Stoco to Deseronto.

—Thos. Rosewarne, of Olinda, will soon have everything ready for sawing lumber. His mill will be situated on the corner of concession seven and the sideroad.

—Mr. John Raney, of North Fredericksburg, has been buying oak timber around Solmerville and at present has quite a force of men banking it near Telegraph Light.

—The Victoria Harbor Lumber Co. are placing a planing machine in one of their mills, which, together with the shingle machine, is to run during the winter.

—The Huntsville Forester says:—The price of pulp wood has assumed its nominal figure, ranging from \$2.25 to \$2.50, and it is thought that it will now remain steady throughout the season. The fight for first place in securing the wood did not last long, as both parties could not afford to pay the high figures of last week. Shipments are kept up and the money for wood delivered is forth coming. A good winters income to our farmers.

—The Walton saw mill commenced running last month.

—During the past few days five men have been obliged to return from the shanties of W. C. Edwards, Rockland and Smith's Falls, suffering from la grippe.

—John R. Selkirk, of the firm of Selkirk Bros., Blytheswood, accompanied W. James, of Cottam, to Missouri; to examine a tract of timber land, with a view of purchasing.

—Taylor Bros. from near Belgrave have purchased the standing timber on the 6th concession township Morris, Huron Co., belonging to R. Irvine and are cutting it into saw-logs.

—The Utterson Lumber Company are busy drawing logs to their mill, and lumber from their Port Sydney mill to the R. R. station. They have altogether about 20 teams at work.

—John Hall, of Orillia, is at Sturgeon Bay shipping telegraph poles. He has about three thousand poles to load. They are all going to be shipped to Black Rock for the present and stored there.

—Mr. McArthur, of the 8th con., Luther, has sold his portable saw mill, and the purchaser, who owns considerable timber land near the Luther marsh, has removed the same and cutting will commence soon.

—The opinion of one well versed in the lumber business in the Ottawa Valley is that about one million dollars less have been placed in circulation by the lumber merchants of this city this season than last.

—Some Toronto capitalists are going to erect a saw and planing mill at Nickle City in the spring. Their agent leaves in a few days to choose a site and make other arrangements to put the building up.

—The Ridgetown Plaindealer\* says:—"Geo. Middleditch has purchased from the Federal Bank, the building and site of the Ontario Planing mill and lumber yard, and is using them for storage of implements.

—The Thos. B. Tait steam shingle mill, just south of Burk's Falls is already at work and a good cutting this season is expected. From present appearances this fine mill will be a lively spot throughout the summer.

—"Loo" Forbes an axeman in Howry's Manitoulin camp fell on Friday last with his axe, and the bit coming down on his hand severed two fingers. His hand was dressed by Dr. Carruthers and is now doing well.

—The Case of Woods vs. Bissennette, in which the plaintiff claims \$15,000 for the loss of both hands in the defendant's saw mill at Bradshaw, will be tried at the spring assizes at Sarnia. Messrs. Lister & Cowan are attorneys for the plaintiff.

—Mr. P. Creary, Cooksville, the saw-mill man, has made an assignment for the benefit of his creditors. At a meeting of the latter on Saturday last, Mr. Creary offered to pay ten cents on the dollar but the creditors wanted sixty-two cents. The meeting was adjourned for one week.

—Mr. Thomas O'Connor, Ottawa, who is lumbering at Little Current, several hundred miles up the C.P.R., reports that the lumber camps will have to be broken up pretty soon at the present rate of going, as there are only six inches of snow covering the ground, making hauling operations difficult.

—Mr. W. S. Hay, of Falkenburg, Muskoka, is behind Shaver & Co., who have a contract from Flatt & Bradley for two million feet of hemlock. Upwards of 100 men and 20 teams are in the woods cutting and skidding logs. Mr. Hay handles some 200,000 ties and 4,000 cords of hemlock bark annually.

—When Mr. A. Dreany was again brought before His Honor Judge Deacon, on the charge of cutting and stealing eight pine trees on J. R. Booth's limits in the township of Ferris, the Crown Attorney did not offer any evidence and Mr. Dreany was acquitted. It is said that an action for false arrest will be taken by Mr. Dreany.

—Mr. Terrence Maguire, of Ottawa, has sold out his interest in the timber limit recently purchased by a syndicate from the E. B. Eddy manufacturing company of that city. The consideration is said to be \$9,000, which represents a clean profit. The syndicate is now composed of Messrs. McRae, Ottawa; Powell, of the Rathbun Lumber Company, Ottawa; and W. Bell, of Pembroke.

—Early last November the stores of the Muskoka Mill and Lumber Co., were burglarized and a quantity of flour, cheese, tobacco, &c. stolen. Suspicion was at once directed towards a gang that have of late years acquired an unenviable notoriety. These suspicions appear to have been confirmed. Jas. Landrigan, Edward Perrault and three of his sons, George, John, and Joseph, the parties suspected were arrested. Bill Perrault the big brother cut and run for it and escaped the arrest.

—Mr. Wm. Rankin, of Toronto, has purchased the old Hobson & Wilson saw mill at the Huntsville locks. He is advertising for a quantity of different kinds of timber.

—The Cartwright mills formerly run by Mackenzie Bros. are being thoroughly renovated by Cook & Co., of Toronto, who will carry on both a flouring and planing business on a large scale.

—The Shannon Shingle Co., of Toronto, imported the first 10 block shingle machine ever shipped into Canada. It was purchased through Perkins & Co. of Minneapolis. The Dominion Government charged the Shingle Co. \$500 duty for their enterprise and pluck.

—Reeve Hughes of Oliver has caused the issue of posters calling a public meeting at Murillo, Algoma District, for the purpose of considering the advisability of granting a bonus of \$3000, to apply towards the erection of a saw mill in that municipality. Evidently Oliver township is bound to keep up its end towards bringing industries into the district.

—Pulp wood is all the rush at Novar. Mr. Huckins is getting out about one hundred cords, J. Keef about the same amount. Barney Wickett has bought the timber on A. Fisher's lots and will take out a lot, and Mr. Durham is taking pine off the same lots. Mr. Bruce is taking out 800 ties, and altogether business is pretty brisk.

—On the 3rd Jan., Alexander Dreany tax collector of the township of Ferris, was charged before Judge Doran of North Bay, with having feloniously stolen and destroyed eight pine trees on one of J. R. Booth's limits, on the 15th of December last. The prisoner was committed to stand his trial. On being brought before His Honor Judge Deacon on Saturday, Dreany elected to be tried by the Judge, pled not guilty and said he was ready for trial. Mr. J. H. Metcalf asked an adjournment, as the crown had to bring witnesses from North Bay. The Judge adjourned the case.

—The extensive alterations at Mr. J. R. Booth's mills, Ottawa, are progressing rapidly, and a large number of men are engaged. The work involves the lengthening of Mr. Booth's flume and construction of an entirely new mill in the place of the one known as the "small mill." This mill will be equipped with eight band saws of American and Canadian make run altogether by rope transmission instead of rubber belting, as is generally used. In Mr. Booth's stone mill, a pair of circular saws will be placed, and a wick' gate in the place of one of the old ones.

—Mr. O'Neil, foreman at Messrs. Booth & Gordon's shanties on Kaskan lake, has arrived in Ottawa for a few days. He states that there is snow to the depth of 28 inches between Kaskan and Boisfrance. The ice took well enough but the heavy snowstorms have made it very rough. There are fifty-eight men altogether employed at Booth & Gordon's shanties and cutting is going on very briskly. Up to now about 40,000 logs, principally white pine, have been cut. The weather just now is delightful and very favorable for hauling. Mr. O'Neil says they do not expect navigation to open until 12th or 13th May.

—Mr. John White and Mrs. White, of Wisawasa, Nipissing district, with their infant daughter passed through Ottawa last month on their way to Grenville, their former home. Mr. White is captain of the steamer J. R. Booth, plying between Wisawasa and Sturgeon Falls. All the little villages on the lake are, he says, growing rapidly though the depression in the lumber trade has temporarily checked their prosperity. At Wisawasa, Mr. J. R. Booth is erecting a large lumber mill and that village is sure of a boom next summer. There are a good many Ottawa people in the district and are all doing well.

—Judgment in action brought by James Haw, of Orillia, against Peter Shaw, of Novar, and tried at the Barrie assizes. Action for damages for standing timber cut by the defendant upon lots 22 and 23, in the 5th concession, and lots 23, 24, and 25 in the 6th concession of the township of Perry, the plaintiff claiming the sole right to cut timber therefrom under a purchase from one J. H. O'Neil and an indenture dated 29th April, 1890. The defendant also claimed the right under a purchase from the same man and a memorandum in writing dated 23rd January, 1889. The learned Judge comes to the conclusion that the sale to the defendant by O'Neil, having regard to time within which the timber was to be taken off and other circumstances, was not a sale of interest in land, and also that it does not come within the operation of the Bills of Sale and Chattel Mortgage Act. Action dismissed with costs. If the interim injunction order provides for damages to be paid by plaintiff to defendant, there will be a reference to ascertain them to the local registrar at Barrie. Proceedings stayed till after the second day of the next sittings of the Division Court. McCosh & Gunn, Orillia, for plaintiff; Adair, Bracebridge, for defendant.

—Mr. Spearing is getting out knees for the Maine market around Foxmead.

—The influx of camp men during past week into Burk's Falls indicates that log cutting is nearly at an end for the season.

—Large quantities of ship knees are being shipped from Uthhoff to the State of Maine. Standing timber around Uthhoff must be worth seeing if the measurements of the following knee are any index to the general cut. Stock, 8 feet long, from heel to toe, seven feet six inches, sided down to eighteen inches, with a face of forty-six inches.

—Mr. Denis Dewney, who owns extensive farms up the Gatineau, and Michael Hayes, of the township of Wright, Ottawa County, Que., returned last month from lumbering in Wisconsin. They state that operations are suspended in the woods of that State owing to the absence of snow, throwing 6,000 men out of employment, fully one-third of the shanty-men being Canadians.

—Mr. Pierce, of Pierce & Co., has returned to Ottawa from England, whither he went on business. From January 1st, Price & Pierce's Liverpool branch ceased to exist. Thos. B. Neale, who has been their Liverpool manager since that branch was opened, has taken over the offices and is now carrying on the business in Liverpool in conjunction with Frank Harrison, under the style of Neale, Harrison & Co. They will act as the Liverpool agents for Price & Pierce and several other lumber firms.

—J. J. Birdsey, representing the cooperage stock house of Sullivan, Innes & Co. at Chatham, Ontario, was in Minneapolis during the week. This firm ships some barrel stock to Minneapolis, notwithstanding the duty thereon which amounts to \$30 per car, and the comparatively high freight rates between their mills and this point. Mr. Birdsey says the outlook is for a light crop this winter in that section as well as in Wisconsin and Minnesota. His company owns four factories of its own and is said to control thirteen more, thus giving it practically a monopoly on the business of the territory in which it operates.

#### QUEBEC.

—Alfred Trotter, saw mill, Victoriaville, has assigned.

—Mr. D. N. Morgan intends starting his saw-mill at Bronie Corner in a few days.

—Millmen in the Lake St. John district, say they will get out about 300,000 saw logs this winter.

—A gang of men will leave Hull for British Columbia to work in the shanties for the Cohen Bros., Feb. 1st.

—It was reported that Smith, Wade & Co., Quebec lumber merchants, were going to assign, with liabilities of \$162,000.

—Wesley Coates of Brookburg has moved to Dunswell; where he and his brothers have a big job lumbering for Milan Bishop.

—Several lumber firms in Quebec will lose by the failure of the well known timber house of Potsman, London, one to the extent of \$10,000, and the other about \$12,000.

—The purchase of ties at St. John's, mainly tamarac, by Mr. Supt. Futvoye, for the C. V. R., means the payment to our farmers and foresters, etc., of some \$40,000 this winter.

—Notwithstanding the statement that the best pine in Gatineau township has been exhausted and the business long since abandoned, James McGuire may be seen passing every day with some fine timbers which he sells to James McLaren, of New Edingburgh.

—Mr. McWalour, of Plummer, has purchased a tract of pine containing 8,000,000 feet from Quebec parties, and is now engaged in manufacturing the same into marketable logs. There is a spur being built for his accommodation, from the line recently completed to Lynch's Landing.

—The report of the building inspector shows that there were 937 buildings erected in Montreal last year, valued at \$3,308,606, as compared with 1,033 buildings, valued at \$3,608,500, in 1889, a decrease of \$299,894. The tenements included in these 937 buildings numbered 676, and stores 126.

—There is a probable settlement being consummated very shortly in connection with the failure of P. Whorton, lumber merchant, England, when it is expected that ten shillings in the pound will be paid the creditors. Messrs. John Burstall & Co. and Messrs. Dobell, Beckett & Co., of Quebec are creditors, the former for \$8,000 and the latter \$4,000.

—The lumber shipments from the port of Montreal to the United Kingdom in the past season were 160,650,526 feet board measure, and from Pierreville 10,427,863 feet, a total of 171,078,289 feet. From Montreal to the River Platte, 3,862,699 feet were shipped, and from Lower St. Lawrence to the same destination 3,798,000 feet, making a grand total of 178,738,988. The lumber exports from Montreal for '89 amounted to 179,306,860 feet against 136,767,264 feet in '88.

—The report appended is from William Westby, 426 Commercial St., Portland Me., correspondent of the *Sherbrooke Examiner*:—The past two or three weeks have been uneventful in lumber circles, for which state of things the season and weather are largely responsible. Most of the winter mills are now sawing and prices seem to be hanging in a balance awaiting the demands, and then probably output of the mills. Salesmen made one round before the holidays, amongst their customers, and report orders scarce, yard stocks low and dealers unwilling to buy, and collections hard to make. Beyond a few sales of frame and random very little is doing. The receipts of birch, maple, &c., are as limited as the price; very little demand and very little offering. In fact the market is so dull that every one has ample time to enjoy the holidays without interfering with their business. Exporters received an electric shock last week in the information that one of the more fortunate had sold a cargo of Spruce for Buenos Ayers, and the rumor was confirmed by the sudden appearance of the vessel to load. This actually makes two vessels loading with spruce for River Platte. But the price—well, there is silence on that point, and there is little use of guessing. There is no demand at all, and when there is no price except the nominal. At this season and time for closing books and stock-taking the prices will show on the stock books as follows:—Scantling \$12.50 to \$13.00; Seconds \$11.00; Rails \$15.00 to \$15.50; Seconds \$12.00; Boards and Plank, 10, 11, or 12 inch., \$15.00 to \$16.00; Seconds \$12.00 to \$13.00, for the South American trade. Spruce frames for the Boston market, \$15.00 for ordinary, and \$16.00 for heavy; random and yard orders \$13.75 to \$14.00. The heavy fall of snow has greatly retarded business and premium on gold at Buenos Ayers still holds at 200 per cent.

#### NOVA SCOTIA.

—Some State of Maine lumbermen have just purchased 60,000 acres of lumber lands on the Koswick river, York Co., N. S., and its branches. They will cut for the American market.

—M. G. Wall, who is cutting lumber for the Shulee Lumber Co., cut one day this week 35,000 feet of deals and boards with his mill, which is one of A. Robb & Sons heavy portables consisting of 50 h. p. Hercules engine, and 60 h. p. Monarch boiler, medium heavy stay and gang edge. Mr. Wall expects to cut 2,000,000 feet this winter.

—Farnsworth & Jardine, of Liverpool, reported that arrivals from British North America during the past month have been 21 vessels, 14,001 tons, against 19 vessels, 14,774 tons, during the corresponding month last year, and the aggregate tonnage to this date from all places during 1888, 1889 and 1890, has been 410,424,538,531 and 456,166 tons respectively. They report imports of New Brunswick and Nova Scotia spruce deals, although less than the same month during the past two years, were more than ample, the consumption being small, and the present stock too heavy. Recent sales have been at the lowest point recorded during the season. Birch logs were imported moderately, and maintain their value, and the stock moderate. Planks were not imported, there being more inquiry, and the prices show a slight improvement, but the stock is sufficient.

—The following is a comparative statement of the shipments of deals from West Bay, N. S., to the United Kingdom:

Shippers.	1889.		1890.	
	Deals, etc., s. ft.		Deals, etc., s. ft.	
W. Malcolm McKay.....	16,997,331		15,978,837	
George McKean.....	6,794,372		11,384,599	
B. Young & Son.....	3,537,853		4,872,868	
Farnsworth & Jardine.....	3,869,893		329,882	
Total.....	31,198,949		32,566,185	

The tonnage engaged in last year's shipments was as follows:

Shippers.	No. of vessels.	Tons.
W. Malcolm McKay.....	18	17,325
George McLean.....	16	12,792
B. Young & Son.....	6	5,429
Farnsworth & Jardine.....	1	412
Total.....	41	35,958

#### NEW BRUNSWICK.

—Morrison's mill, at Fredericksburg, began sawing last month.

—The large trade done in New Brunswick birch has almost entirely fallen off.

—Mr. W. M. McKay shipped 106,360,460 s. ft. of deals, &c., from New Brunswick ports to the British and Continental markets during the season just closed.

—During the season just ended 10,014,103 superficial feet of deals, etc., were sent forward to transatlantic ports from Bathurst. This total does not include 198,000 feet of birch deals shipped by the St. Lawrence Lumber Company.

—The demand for shingles at Boston has given an increased impetus to the business in Fredericton. One shingle mill, which closed down for the season, has resumed operations owing to the increased demand. These shingles are sent direct to Boston over the Canadian and Maine railways, and are proving a profitable business to the people interested in Fredericton.

—The lumber shipments from the northern portion of New Brunswick during the season show a falling off as compared with 1889. The present year the shipments amounted to 132,000,000 superficial feet against 162,000,000 feet the previous year, a falling off of 30,000,000 feet. Baie Verte sent in round numbers 11,000,000 superficial feet to the United Kingdom and Parrsboro 32,566,168 feet.

—There is at present about three feet of snow in the Miramichi woods, and yarding is about finished. Lynch, Richards and other extensive lumbermen are now taking on more teams to haul in to the streams. Wm. McCluskey of Boisetown, has some hundreds of cords of hemlock bark piled beside the railway waiting for shipment to the States. Some loggers are talking about leaving the forest as snow is getting deep, and the prices of food for men and horses getting too high.

#### MANITOBA AND THE NORTH-WEST.

—Dean & Heathcote are starting a sawmill south of McGregor.

—Robinson & Co., lumber manufacturers, of Selkirk, have opened a branch of their lumber business in Winnipeg.

—The rumor has been revived that the Keewatin Milling Company will dispose of their business to an English syndicate of capitalists.

—The Messrs. Hedley and Mr. Geo. Patterson are hauling in lumber from Deloraine to Cardville preparatory to building new houses in the spring.

—The Lake Winnipeg Lumber, Trading & Transportation Company is in financial difficulties and will probably go into liquidation.

—Some 25,000 railway ties lying at Tyndall station, the property of A. C. Bryson, Winnipeg, have been seized by the sheriff.

—McArthur & McRae, who have a saw mill north of Shoal Lake, have cut a road to Shoal Lake, and will open a lumber yard there.

—The "Messiah Craze" found its way up to Onion Lake, but Mr. Agent Mann had too much work on hand to give his Indians time to dance. He set them saw-logging.

—Owing to the difficulty in obtaining a suitable building or lumber required to build a new rink, the committee appointed to organize a curling club at Emerson have thought it better to abandon the idea this winter.

#### BRITISH COLUMBIA.

—Mr. R. Cunningham is building a shingle mill on the Skeena River.

—The Simmons, Burpee, Elkin & Smith shingle mill on Vancouver road will shortly be under way.

—Mr. G. F. Slater, proprietor of the Vancouver Shingle Mills, is enlarging his plant and introducing additional machinery for the manufacture of all kinds of lumber.

—The Canadian Pacific Lumber Company, of Vancouver, propose to erect a large saw mill at the mouth of the Amacon river, down which logs will be floated to the mill yard. Ships can load in these waters.

—The McLaren-Ross Milling Co. are now exploring a road from the Mission to their extensive limits on Stave Lake, as it is understood they have large timber contracts with the railroad people.

—A double car of sill lumber was shipped from the Royal City Planing Mills, New Westminster, for the Barney-Smith Car Manufacturing Company, of Dayton, Ohio, last month.

—The Columbia River Lumber Company are operating two saw mills at Beaver, near Donald. There is considerable valuable timber in that region.

—Mr. Angus Fraser has just finished a large contract for getting out logs for the Cowichan Mill Company, and is going to start at once on another one for the same company.

—The first shipment of lumber consisting of seven carloads, from British Columbia for the Boston market, passed through Ottawa recently via the Canadian Pacific railway.

—A new shingle mill is in course of erection at Westminster for Elmer Ward, a young man from Fredericton, N. B. The capacity of the new mill will be about 30,000 shingles per day.

—The Davies-Sayward saw mill at Pilot bay, on the east side of Kootenay lake, is now near completion. The mill owners have called for tenders for delivering 500,000 feet of logs at the mill this year and 3,000,000 feet next year.

—Mr. N. Slaght, manager for the firm of Michigan lumbermen who intend building a saw mill at Steveston, has arrived at Victoria from the east. Mr. Slaght brought the news that he had instructions to build the mill with a capacity of 200,000 feet per day, instead of 150,000 feet as first intended.

—The ships Titan and Ellen A. Reid have arrived in the Royal roads to load lumber at the Hastings mill. Both ships report a very rough passage, two or three cyclones being encountered, which carried away or split sails and otherwise played havoc with the rigging. No lives were lost.

—A large force of men is employed at the Vancouver mills, owned by Webster & Edmunds, and the concern is certain to become one of the most important in the province. The North Pacific mills, at Burnett, are being rushed to completion, and will be among the largest in the country.

—T. W. Clark is about starting a store on Gambier island in connection with his saw mill. There is a constantly growing trade up there among logging camps, settlers and Indians, who will, no doubt, find this departure of Mr. Clark's a boon, as it will save the expense of going into town on any occasion when grub runs short. The saw mill has a capacity of 40,000 per day and most of the timber is sold down in Victoria.

—The Brunette saw mills, Sapperton, are closed down for repairs, but the establishment will be running full blast again in a week or two. Taking advantage of the mills being closed, the company is having a massive bridge constructed over the Brunette river, which, when completed will be crossed by a spur from the Canadian Pacific railway. This will permit of cars being taken to any part of the company's yards for loading.

—The Royal City mill has a capacity of 45,000 feet of lumber, 40,000 lath, 30,000 shingles and 150 doors in 10 hours. In addition molding, sash, turned wood work and all kinds of house furnishings are executed. A specialty is made of fine mantels from native woods. Employment is given 95 men and \$5,500 paid monthly in wages. The market for the production of this mill is principally local. But considerable is shipped abroad, especially to China and Japan.

—The saw mill of Mr. Andrew Haslam, at Nanaimo, is one of the most complete in the country, and has the newest and most improved machinery. Its equipment comprises the following: Three boilers of about 130-horse power; five steam engines; one pair of circular saws, with patent blocks; one fifty-inch gang edger, with six saws; one gang of counter-balanced compensating saws; Trimmers' lath and picket machine, etc.; one fast feed heavy flooring machine; one planer and matcher; one automatic filer, and all the necessary tools found in a complete modern mill. Besides the saw mill, Mr. Haslam runs a large sash and door factory, with all the modern and most improved machines and tools. He does a large business in this line, and both establishments together give employment to forty-five men.

—The new saw mill being erected on Burrard Inlet near Port Moody will be a very large establishment. The main building will be 300 feet and its height two stories. The capacity of the mill will be 100,000 feet per day, besides shingles and lath. A mammoth new burner to consume the refuse will also be erected, 22 feet in diameter and 120 feet high, with double iron casing and many new improvements. The mill will be driven by two large engines, 600-horse power, and six boilers. The company own some 120 acres of land at the mill, besides large timber limits in different parts of the province; and from the mill lumber can be shipped by rail and vessel to any part of the world. Next spring a large dock will be built, 100 feet wide and 3,000 feet long, the whole length of the mill on the north where the largest ship can load. It is expected that the mill will be completed and running early next spring. Mr. James B. McLaren, formerly of Ottawa, is the business manager and part owner.

—The excelsior mill at Popcum is a grand success, and the proprietors, Messrs. Knight Bros., are delighted with the result of the venture. Through the general agents for the output of this mill, Messrs. Campbell & Anderson, of this city, orders have been received so rapidly that they cannot be filled as promptly as could be desired, and the result of the first two weeks manufacturing has determined Messrs. Knight Bros. to immediately double the capacity of the establishment. With this end in view an order has been sent forward for another excelsior manufacturing machine, and it is expected to be in operation by March 15th. Orders are now on hand which will keep the mill busy for the rest of

the winter, and when the new machine is in, the factory will be able to cope successfully with the spring trade. Samples of the excelsior have been sent to Manitoba and the Western Territories, and some large orders from that direction are sure to follow. The American manufacture will soon be excluded from the Province by the home made goods.

—Several lumbermen from Ottawa are looking towards British Columbia as likely to be one of the most profitable fields for operations in the near future. A considerable quantity of lumber from the Pacific coast is now being shipped to the eastern markets, and in that direction a fairly remunerative business is being built up. J. W. McKay, of this city has received an order from Boston houses for a shipment of six carloads assorted lumber from the Burnett mills at New Westminster, for which he is the eastern agent. He states that a large quantity of Douglas fir is now being used in car building, where oak was formerly used, it having been found that this wood does not have the same deteriorating effect upon the iron work of cars, as has oak. With regard to the output of the Burrard Inlet mills for 1890, it may be said that the Hastings mill produced during the past year 14,600,000 superficial feet of lumber, valued at \$175,000. Shipments to foreign markets were 11,000,000 feet. Fourteen sailing vessels were loaded with a tonnage of 16,863. The number of men employed at the mills was 150 and at the logging camp 150. The wages paid by the company will average \$150,000 yearly. Owing to certain alterations and repairs being made, the mill has only been in active operation about six months this season.

### PERSONAL.

Mr. E. W. Rathbun, of Deseronto, was in Toronto recently.

James Hector McLean, city editor of the Toronto *World* died of heart failure on the 27th ult.

Mr. G. A. R. Simpson, of the Hull & Dacey Lumber Co., of Minneapolis, U.S., was in the city in January.

Mr. C. H. Clark, of Burton Bros., lumber merchants, Barrie, paid us a flying visit. Their mill at Byng Inlet, with one circular and one gang, cut 15,000,000 feet last season. The firm disposed of 17,000,000 feet of sawn lumber.

A. McLaughlin has been presented with a gold headed cane by the employees of the Royal City Planing mills, New Westminster, B.C., on his retirement from the position of foreman to take an interest in a new milling enterprise.

Mr. W. J. Conroy, who was elected Mayor of the town of Aylmer by acclamation, for 1891, is a member of the lumber firm of R. & W. J. Conroy, who own and operate extensive saw mills at the Duchesne.

J. E. Davidson, Toronto, has been about ten years in a planing mill. In June, 1888, his affairs were found badly mixed, and an assignment was made. This year he made another assignment.

A well known and wealthy lumberman of New Brunswick, Mr. S. T. King, died recently, aged 80 years, in Chicago, of paralysis. He was for a time business partner of Alexander Gibson, the millionaire lumberman.

Terence McGuire, a lumberman of Ottawa, is the relator in *Reg. ex rel. McGuire vs. Birkett*. The case is an attempt to upset Birkett, the Mayor elect of Ottawa.

Reid & Co., the well known wholesale and retail lumber merchants on Esplanade street, at the foot of Berkeley street, although twelve years in the trade, are getting badly mixed up with a new firm in the city doing business under the name and title of Read & Co.

Mr. T. W. Dobbie, of Toronto, is in British Columbia, where he owns several large tracts of timberland. Mr. Dobbie says that St. Paul, Chicago and New York capitalists are buying up all the timber limits they can secure in B. C.

Visitors at the office of the CANADA LUMBERMAN, during the past month: F. H. Dobbin, manager *Review* Pub. Co., Peterborough; G. V. Stocking, manager Georgian Bay Lumber Co.; T. S. McCool, late of Toronto, now associated with an Albany lumber firm; C. H. Clarke, Barrie, Georgian Bay Lumber Co.; F. J. Drake, Belleville; Gibson Collenson, Aberdeen; Jas. Crawford, Durham.

John A. Howe, jr., Albany, N.Y., for years closely identified with the lumber trade, has made a new departure. His connection with the business will not cease, but in future additional worry and care will furrow his brow through the interest he has assumed in the cereal industry. Rice, we believe, will receive his special attention. John will be an authority on kindling wood. Bad kindling wood is a great disturber of domestic peace. He will be able to select the proper "birch" for the nursery and lastly—and this is the key to success in married life—he

ought to be an adept in throwing "saw dust" in his letter half's eyes. May pleasure, comfort, happiness attend you John A. through the coming years.

Enquiry justifies us in saying that Reid & Co. and Read & Co. are distinctly and entirely independent and separate firms. The latter is about six weeks or two months old, and is managed by Mr. Jno. Eyer, at one time with the Toronto and Midland Mfg. Co. Millmen and others interested, for the prevention of confusion, are respectfully asked to make a note of this.

E. G. Thomas, Woodstock, manufacturer of the *T* organ died on the 28th ult. The deceased was born in Toronto in 1853, was manager of the Toronto Organ and Piano Mfg. Co., went to Woodstock in 1875, served as alderman and member of the County Council, identified himself prominently with the Oddfellows and Freemasons, and was highly esteemed.

About a year ago Wm. E. Sherman, of Buffalo, got considerable notoriety in Toronto owing to an attempt to extradite him, which finally failed. A report from Buffalo now announces that his brother, Stephen F. Sherman, has been sentenced to five years there for grand larceny, at hard labor. The brothers composed the firm of Sherman Bros. & Co., grain dealers, and they did up the community to a large amount on fraudulent deals. Both came to Toronto, but Stephen returned to Buffalo, and was arrested, while William successfully resisted extradition.

A half tone portrait of Robert Dollar, Esq., of San Francisco, with a short biographical sketch of his life, appears in one of the January numbers of the *Northwestern Lumberman* published in Chicago. Some Canadian papers have since published sketches but the *N. W. Lumberman* covers all the ground. Mr. Dollar was born in Falkirk, Scotland, 46 years ago, but emigrated to Ottawa with his parents at the age of 13. Like many other boys raised in Ottawa, the vast lumber industries of the Chaudiere left their influence, and Mr. Dollar took to lumbering and followed the branch of the trade known as a "logger." Muskoka and Georgian Bay were the districts operated in Canada until 1890, when he removed to North Michigan and engaged in the square timber output. He founded Dollarville with its saw mill and made his home at Marquette temporarily.

### BRITISH COLUMBIA MATTERS.

NEW WESTMINSTER, B.C., Jan. 21st, 1891.

Our weather keeps very fine and mild and shows no signs of changing. It is not likely we will have any ice this winter. Our fish exporters are greatly troubled over this, and are laying plans to go 250 miles up the C.P.R. to Kamloops lake and bring the ice down by C.P.R.

Two ships are due shortly to load bridge timber at Messrs. Webster & Edmunds mill on Burrard Inlet, for South Africa. A good sea going tug is badly needed on the Inlet.

Messrs. Morse Bros. recently loaded a ship in Coal Harbor bound for Chili. This necessitated a much longer transport by lighters, but was deemed better than lying in English Bay, at the outlet of False Creek, on which Morse's mill is situated.

Messrs. Purdy & Dixon have only just received the necessary permission to cut timber for their new mill near Mission. It was not recognized by the Dominion Government as a timber claim, and still the settlers had no right to dispose of it before obtaining their patents, hence the delay.

Many of the logging camps are still at work, and may not stop this winter unless it turns cold. The mills are kept busy cutting and are looking forward to a very busy season during 1891.

The tug Alert of Victoria left Slater's mill, Vancouver, recently with a scow loaded with 600,000 shingles consigned to Richardson & Heathorn, of Victoria. The Victoria firm is going extensively into the lumber trade, and is handling the cut of the West Bay Saw Mill, Gambier Island.

J. H. McLean purposes establishing a sash, door and blind factory at Revelstoke, and has ordered the necessary machinery from Galt, Ont.

Very heavy rains two and three weeks ago helped stream driving very much and brought down logs that were only expected to reach the mills in May or June next. It also caused considerable damage in carrying away booms, logs, bridges and fences. Greater loss of property occurred on the island than on the mainland.

Hasting's mill is closed down for repairs, amongst which will be the putting in of a new carriage and saw rig.

I have been trying to obtain the cut of all mills in British Columbia for 1890, but have received only two or three so far. I hope to have all in for my next letter.

H. G. R.



### THE CARRYING TRADE.

PERHAPS in no branch of our progressive civilization has greater strides been made than in the carrying trade. Within the memory of many now living a distance which formerly required weeks to travel may now be passed over in a few hours; and weights which we could not then carry may now be tossed about as of little or no account. The wagon roads, except for the convenience of the farmer or the pleasure of those in easy circumstances, are little used. The railroads are almost entirely used by passengers and by forwarders of perishable and light commodities, while the water-ways afford such satisfactory facilities for the removal of heavy freights that it is an object of the shipper to try and reach them.

To our young country, of sparse population and immense distances, no question is of such paramount importance as speedy, safe and cheap transportation. Not only has this been the case in the past but it is so to-day, and will continue to be so even to a greater extent in the future. As the water-ways are open to all and cannot be monopolized by any one, let us first glance at the lake trade and its effects on the charges for forwarding freight. Of late lake shipping has greatly increased and improved. A few years ago the greater part of the carrying was done by sailing vessels; now the greater part is carried by steam, and the tendency is progressing so that before long, except for very special purposes, steam will have superseded sail almost entirely. Again, the harbors are being enlarged and the obstructions removed, and the capacity of the vessels is greatly increased. As the trade is in the hands of so many, reliable returns were difficult to obtain. Mr. C. H. Keep, the secretary of the Lake Carriers Association, has lately presented a case to the Congress of the United States, setting forth forcibly and clearly the lake trade and its marked development in the last five years. He shows that the lake trade is now greater than that of the Atlantic coast trade of the United States.

During the past year (1890) the lake fleet engaged in business, no way connected with the government, consists of 2,055 vessels of 826,360 net registered tons, of the value of \$58,128,500. Of these the steam vessels are 1,153, with a registered tonnage of 523,702 tons, valued at \$48,434,350. The sailing vessels are 902, with a registered tonnage of 302,658 tons, valued at \$9,694,150. 232 steamers have a net register of over 1,000 tons, and 110 have register of over 1,500 tons. The value of the fleet has nearly doubled in the last five years, while its capacity, speed and safety have immensely improved. In 1886 there were 21 steamers that registered upwards of 1,500 tons; last season there were 110. In 1886 only six of the vessels on the lakes were steel, valued at \$694,000, while last season there were 68, valued at \$11,964,500. According to the last United States census, though there are grave doubts as to the accuracy of the returns, the volume of freight carried on the great lakes reached 27,417,598 tons. It is said that 36,000,000 tons passed Detroit, and according to the report just issued by the superintendent of the Sault Ste. Marie canal, 9,041,000 tons passed through the lock on the American side. Careful returns might therefore show the lake freights to exceed 40,000,000 tons. In the absence of more reliable figures for the last season we may take the figures of 1889. In that year there passed through the "Soo" canal 7,650,455 tons, valued at \$83,732,527.15. On the same basis the total value of the freight carried would be \$305,432,044.72 for 1889, while the amount would be greatly increased for the season just closed if we could find the figures, which, however, are not yet made up. In the absence of a better standard the trade has endeavored to ascertain the average charges for carrying one ton one mile. The unit is found by reducing the entire freight carried for all distances, to the number of tons carried one mile and dividing it into the entire freight charges collected. Results will more nearly approach perfection as returns become more accurate. This supplies a means more or less accurate of reaching and comparing results. The volume of freight would thus be 5,940,646,352 mile tons, on which was collected

\$8,634,246.63, making the average charge per ton per mile on the lakes one mill and a-half. This average rate must continue to fall as the waterways are improved and the capacity of the vessels increased. Frequently the ocean rates do not equal one mill per mile. Of course lake freights must always continue higher than ocean rates. Mr. Poor is a standard authority on railroads in the United States, and he gives his figures to show that the average cost on the railroad for 1887 is a shade over one cent and one mill per ton per mile. In the last issue of his manual it is a shade less than a cent, and Mr. Adams the statistician associated with the Inter-State Commerce Commission of the United States, gives the average at 9 mills and 22 hundredths of a cent. The average by rail is therefore fluctuating round a cent per ton per mile. This difference is an ever varying quantity, but as the large freight railway car has reached about its greatest capacity, and the vessels are daily improving, the change must be in favor of water rates. We may therefore for the present estimate the rates by water at three and by land at 20, or the water rates at nearly one-seventh of the land rates. Before a great time expires it may be found to be as one to ten, as dimes by water to dollars by land. We have endeavored to make this mode of comparison as clear as possible, as it is generally employed for the purpose of roughly ascertaining results.

Without further enlarging on the lake trade, its importance is clearly shown by the statement that though the volume of freight on the lakes does not reach one-fourth of that carried in the United States, the saving to those interested on last year's trade reached not less than \$120,000,000. While the shipping on the lakes has increased by leaps and bounds, the railroads have been steadily progressing. The road-beds have been improved, and the rolling stock increased. These improvements have also lowered charges to some extent. Every effort has been made to meet the wants of the people, and much has been accomplished, but with all the efforts made to supply the demands of the public, the carrying trade is to-day more congested than it ever was before. Why is this? It is quite apparent that it arises from the increased and ever increasing population settling within the carrying influences of the lakes.

The Northern Pacific in four years increased its gross earnings from \$12,000,000 to \$24,000,000, and the Canadian Pacific has made equally marvellous gains. So, indeed, with most of the Trunk lines; their receipts have passed all expectations. Notwithstanding every improvement, the cry is for greater facilities. The merchants, through the Boards of Trade and otherwise, have brought the greatest pressure they could on the carriers to increase their facilities, but the demands have not been satisfied. The plain truth is that with all the improvements, both by water and land, the carrying capacities are not equal to the demands of the trade. What is to be the remedy? Increased water or rail accommodation, or both; or by some new plan combining both. This subject we may be able to examine in a future number.—*Canadian Miller.*

### MY GHOSTLY GUIDE—A LUMBER MERCHANT'S STORY.

IN January 1853 I was engaged as assistant clerk in a large lumbering camp in the woods about a hundred miles north of the Ottawa river. Our main shanty was by the side of an outlet of Red Pine lake about two miles from the south side of the lake itself, a sheet of water of oblong shape, about a mile and a half wide and five miles long. There was a fairly good road from the edge of the lake to the shanty, and from the north or opposite side of the lake, a road had been made for some miles through the forest, to a point where a smaller camp had been established, and where a number of our men were engaged in making timber. From the main shanty to the smaller one was probably twenty miles. One day my chief, Mr. Simpson, sent me off with some instructions to the foreman in charge of what we called the Crooked Creek camp. I started with my snowshoes on my back and moccasins on my feet, at a brisk pace. It was a bright clear day. The road to the lake had

been well worn by teams, and as there had been a thaw covered with frost, the ice on the lake was hard and smooth. The road from the lake to the Crooked Creek camp was rather rough and narrow, and a stranger might have difficulty in following it. However, I knew the route well, and arrived at my destination in good time, just as the men were returning from their work, with axes on their shoulders. I spent the night in the camp, being asked innumerable questions, and hearing all the petty gossip the men had to relate. It must be remembered that these shantymen go into the woods in October or November and excepting in rare instances hear nothing whatever from the outside world until they come out in the spring. Next morning I executed my commission and about ten o'clock started back for the main camp. I had not travelled more than half the distance when a snowstorm set in. In the woods the flakes fell down steadily, and I had no difficulty in keeping the road. It was about sun-down when I reached the edge of the lake. The snow had covered the track across the ice and there was nothing to guide me to the entrance to the road to our main camp on the opposite shore. Out on the lake the storm was blinding, but I did not doubt my ability to reach the other side and find the road. So I started across the lake. When less than half a mile from the edge of the woods the snow was so thick that I could see neither shore. Moreover it was getting dark and exceedingly cold. If I should lose my way on the lake and have to spend the night there I would certainly perish. What was to be done? I turned in my tracks and managed to reach the north shore again, stepping in the shelter of some bushes to recover my breath. Should I stay there all night? To tramp back to Crooked Lake camp was my first decision, but on reflection I remembered that any person travelling that road at night was liable to be attacked and eaten by wolves. Moreover I was hungry and fatigued. While I was thus communing with myself, jumping up and down and slapping my hands to keep myself warm, I saw a man dressed in a grey suit with a tuke on his head and a scarf around his waist, about 200 yards out on the lake, beckoning to me to follow him. I at once jumped to the conclusion that Mr. Limpson had sent one of the axe-men to meet me and guide me across the lake. So I ran with all my might towards him, calling to him at the same time. When I came close to the spot where he had stood, I looked around. He was not there, but a lull in the drift showed him some distance further on, still beckoning me to follow. No reply came to my calls to the man to wait for me, but every few moments he would appear some distance ahead beckoning me towards him. I could not tell what to make of the man's eccentric behaviour, but thought possibly he was angry over being sent out to look me up, and was taking this method of evincing his displeasure. At last I saw him on the shore, pointing towards the woods, and reaching the spot where he had been standing I found myself at the point where the road to our camp left the lake. The road was easy to follow, and I hurried forward, still somewhat puzzled over the refusal of my guide to wait for me; and wondering also why he had not brought a horse and sled. I reached the camp just as the men had finished their supper, and everybody was surprised at my return. Mr. Simpson said he supposed that even if I had started from Crooked Creek camp in the morning I would have turned back when the snow storm came on. Somewhat bewildered I asked which of the men it was that guided me across the lake and pointed out the road to the camp, "Why did he not wait for me?" I asked in a rather injured tone. The men looked at one another in amazement. Not a man had been out of the camp that evening. Every man had returned from work at the usual time and remained in camp until my arrival. We were nearly seventy miles from the nearest settlement and there was no camp nearer than the one at Crooked Creek. Every person in the camp became restless and nervous. That man who guided me across Red Pine lake was not a being of flesh and blood, was the general conclusion of the shantymen and my description of his disappearances and reappearances tended to strengthen their theory. The experience was such an inexplicable one that very few of the inmates of our camp slept that night. I was grateful for my rescue, and it was evidently that whoever my guide was it was not my destiny to be eaten by wolves or frozen to death in attempting to cross Red Pine lake in a snow storm

**UNITED STATES LUMBERMAN'S DIRECTORY.**

A LUMBERMAN'S directory is in course of publication for the United States by Rand, McNally & Co., of Chicago. This advertising firm have wide experience with works of this nature, and their issue which is promised in April will no doubt be accurate and comprehensive, but it seems rather peculiar that a firm of advertisers of such pretensions should tread right on the heels of the efforts of the *Northwestern Lumberman* who published weekly instalments during 1890 in that journal of the lumber manufacturers and dealers of the United States. It seems peculiar we repeat, that this firm should undertake the publication of a directory at this opportune moment.

There would be very little to add to the *Northwestern Lumberman's* weekly installments and information to make it a hand book of useful information to the lumber trade.

That journal says before giving a synopsis of the results obtained during the year's work :

"In many sections of the country there are general mills which ordinarily do grinding of feed or grain, but which have a saw mill attachment, as it were, which is used on occasion. There are many thousands of other mills which are of no commercial importance. These the *Lumberman* has always omitted from its lists. To thus separate the mills of the country and decide what were and what were not worthy of representation in these columns has been a task fulfilled with as much care as possible, but with no hope that all would be satisfied with the discrimination used. It has been the aim to furnish a list that would be of practical value to our readers, whether those who wished to use them be lumber merchants or manufacturers of machinery and supplies, and at the same time to keep the list within such limits that it would not be unwieldy. This we believe, has been accomplished with reasonably satisfactory results."

States.	Saw Mills.	Shingle Mills.	Planing Mills.	Band Mills.
Michigan.....	877	396	533	100
Wisconsin.....	478	204	304	92
Minnesota.....	105	66	122	14
West Virginia.....	220	15	108	12
Kentucky.....	334	34	134	15
Tennessee.....	442	29	169	31
Missouri.....	223	14	125	5
Arkansas.....	318	55	144	6
Alabama.....	150	21	103	2
Mississippi.....	165	13	85	3
Louisiana.....	109	29	80	5
Texas.....	151	30	141	...
Ohio.....	684	30	596	19
Indiana.....	689	32	356	24
Illinois.....	153	8	248	6
Maryland.....	46	5	60	1
Virginia.....	155	31	103	6
North Carolina.....	160	26	111	8
South Carolina.....	87	9	65	1
Georgia.....	160	57	112	2
Florida.....	132	48	115	...
Iowa.....	48	20	58	15
Kansas.....	...	...	31	...
Nebraska.....	4	...	18	...
South Dakota.....	20	14	22	...
North Dakota.....	...	...	...	...
Colorado.....	51	29	43	5
California.....	762	64	217	9
Oregon.....	192	26	172	...
Washington.....	191	82	195	5
Nevada.....	6	2	4	...
Wyoming.....	10	7	7	...
Idaho.....	46	20	32	...
Utah.....	36	9	22	...
Arizona.....	11	2	5	...
New Mexico.....	16	8	13	...
Indian Territory.....	17	1	6	...
Montana.....	27	11	19	...
Oklahoma.....	...	1	...	...
Maine.....	358	289	295	6
New Hampshire.....	277	160	243	6
Vermont.....	368	129	307	4
Massachusetts.....	304	80	287	6
Connecticut.....	62	22	48	...
Rhode Island.....	12	6	21	...
New York.....	783	259	732	5
New Jersey.....	73	10	92	...
Pennsylvania.....	982	269	815	28
Delaware.....	49	2	29	1
Total for 1890.....	9919	2739	7607	342
Total for 1889.....	9485	2528	7721	330

**LUMBERING IN NEWFOUNDLAND.**

WHILE the great staple of Newfoundland is her fisheries, there is growing evidence that at no distant day the colony is bound to become a timber centre, if not a strong competitor for trade in the English market. There are now 55 mills at work in the great Bay of Notre Dame, or Green Bay, where there is some excellent forest timber, consisting principally of birch, pine, spruce and fir, or as it is called in Canada, balsam. The pine board obtained is closer grained and much wider than what is generally obtained from the neighboring colonies. It is estimated that in Green Bay there 720 square miles of pine and spruce timber, which

if manufactured into lumber, would be worth millions of dollars. Newfoundland is rich in minerals as well as timber, and as capital is seeking investment in that direction, there is no doubt that in the near future these resources will be developed to a considerable extent, as they are in the close proximity to desirable markets.

**FRICITION CLUTCH PULLEYS.**

FRICITION clutch pulleys are designed to supersede tight and loose pulleys, drop tightners, etc., and to avoid the unnecessary work and consequent wear imposed by them upon belts while the machinery is idle. They are extensively used in electric lighting and are very desirable when frequent or abrupt stoppage of machinery is necessary. They are being very extensively adopted in mills and factories of every description, and are especially suitable for high speed service and heavy work. The friction rim only is keyed to the shaft; the pulley and grip mechanism is free or loose thereon. Therefore, when not "in grip," the driving pulley remains motionless, while the shaft revolves freely in the babbled pulley sleeve. Immediately upon being gripped the power is transmitted to the pulley through the grip jaws and ring. When the grip is attached to the driven pulley (located on machine or counter shaft) the pulley revolves freely upon the shaft until the clutch engages with it and causes it to drive the shaft.

The accompanying cut shows a friction clutch pulley made by the Watrous Engine Works Company, of Brantford, Ontario, whose reputation as builders of fine machinery is world wide. It is not only simple, compact and durable beyond all other contrivances,

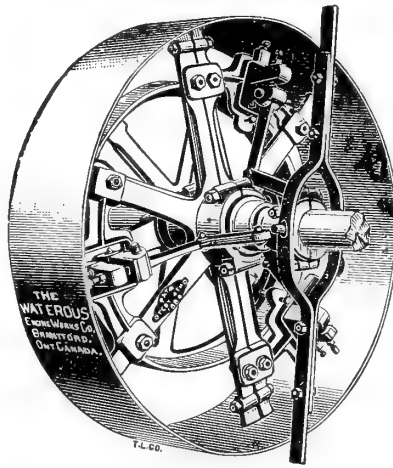

but it engages and disengages gradually, thereby preventing any possible injury. Its final grip however, is more firm and positive than that of any other clutch. The operation of this friction grip pulley and friction grip cut off coupling will be understood from the following description.

The grip ring or rim, instead of being cast to the arms of the pulley, as in ordinary clutch pulleys, is a pulley by itself, securely keyed or fastened with set screws to the shaft transmitting the power, or in the case of a driven pulley, to which the power is transmitted. The grip mechanism is fastened to the arms of the pulley or coupling. In the case of a pulley, the friction rim is made about half the diameter of the pulley. In operating the pulley or coupling, this grip mechanism stands motionless when the pulley is not driving or when the connected shaft is cut off. To bring it into work, the sliding sleeve on the shaft "D" is forced with a lever toward the friction pulley rim, and readily passes beyond the diametrical centre or grip arms, which cause two, four or six sets of friction grips to grasp the rim with an irresistible, vise-like grip.

From the peculiar mechanism of the grips it will be readily seen that the pressure of the inside and outside jaws upon the friction rim is always exactly equal. When desired the power may be applied by degrees and the pulley started gradually, or the sliding sleeve can be thrust in instantly by a quick movement of the shifter, when the pulley or coupling immediately starts at full speed. The friction grips are adjustable. The end of lever is of cast steel, tempered, and engages a small block of cast steel, tempered, let into the under

side of top grip arm. This steel block is adjustable, being hung from the inner end and adjusted by a set screw working from the upper side of grip arm. By this means, any strain desired can be put on the frictions to take up the wear of the friction shoes. The friction shoes are shod with thoroughly seasoned maple, set end on to their work, and will wear many years. The maple is easily renewable, and requires no oiling. When the sliding sleeve is withdrawn the point of lever engaging the steel block in grip arm at once works into a recess formed in the steel block to receive it and permits top grip arm to leave pulley, releasing immediately the grip from the friction rim. All parts subject to wear are renewable at a very slight expense, and without trouble or loss of time, it being unnecessary to remove the pulley from the shaft in order to renew or adjust any worn parts. There is absolutely no contact or frictional surfaces when not in grip. Owing to the short travel of the sliding sleeve, and the fact that it passes the diametrical centre of grip arms, the operation of gripping and releasing is so easy that it can be readily accomplished, and when once the sleeve is thrown into position there is no strain upon it whatever, nor can it possibly get out of grip without being forced by the lever. When desired, these friction grip pulleys and cut-off coupling can be promptly brought to a standstill, even when running at a high rate of speed. This in case of accident may prevent much damage or perhaps loss of life. For further particulars address the manufacturers.

**WE HAVE THEM IN CANADA, BUT NOT REPRESENTING "THE LUMBERMAN."**

THIS is a great month for Bowling Alley Johnson. Mr. Johnson is the young man with the Spanish cast of countenance and raven ringlets who writes B. A. before his name instead of after it, and who goes up and down the country accompanied by a trunk and a small hand bag, in the interest of the *Lumber Trade Journal* of Chicago, telling possum and other stories. The boys call him Bowling Alley instead of B. Arthur, which is the Anglicised form of his proper name. Johnston has one or two peculiarities. One of these is that he never goes anywhere without a certain lean, but eminently proper trunk. It is even reported that if he goes from the south side, in Chicago, to the west side, to spend an evening, he invariably takes his trunk. Certain it is that whenever Johnston is outside of Chicago there is that trunk also. Private levees are given at which the trunk is exhibited to wondering lumbermen and confiding newspaper men who may and may not be connected with the lumber trade press. The trunk has a companion in its travels in the shape of a certain small hand bag that never entirely escapes from the range of the dark eyes of Signor Don Leonardo Bowling Alley Johnson. He obtrudes it into meetings, dumps it on the reporter's table and resents any intimation that it might be checked and left to the tender mercies of the Senegambian in the coat room. But this is wandering. I started out to say that this was a great time for Johnson. There are no less than eight lumber conventions scheduled for the current month and Johnson and the trunk are engaged in a frantic effort to cover them, jumping from the soft breeze and mid-winter salubrious climate of New Orleans and Atlantic to the blizzard belt in Minnesota. Johnson stands it pretty well but if the indications are worth anything at all it is very hard on the trunk, which is lean, attenuated and hungry, while its owner and companion is rotund, happy, and to all appearances well fed at the innumerable banquets which he covers. The Signor will be with us on the 28th and so will the trunk.—*Minneapolis Lumberman.*

One thing, says a writer in the *American Machinist*, which spoils many leather belts is a habit indulged in by some who claim to be mechanics, of when a belt slips putting on powdered resin, or running for a cake of soap and hold that on the belt—either one spoils the belt. When a belt slips take it up; then if it slips put on a wider belt, and in the end it is money in your pocket.

HOME AND FOREIGN TRADE REVIEW.

Office of CANADA LUMBERMAN, }  
Jan. 31st, 1891.

In answer to the usual question "How's trade?" the Toronto lumber dealer simply says "there is no trade." This is the month when all properly managed concerns usually take stock or have completed the job and have ascertained their position.

So far no lumberman has been seen who has confessed to unbounded satisfaction with the results of the year's business.

With that high regard for the truth which is characteristic of the men who wield the board rule, we unite in declaring that the year 1890 cannot by any stretch of the imagination be considered a "boom" year.

In the city and suburb districts there has not been anything in the way of building to compare with previous years. Speculative building received a decided check at the very beginning of the year and for this a variety of causes are responsible. It became apparent early in 1890 that house building had been overdone. On outlying streets whole terraces stood vacant, and rents declined to figures which left very little margin of profit to the proprietor. The loan companies advanced the rate of interest and scrutinized progress loans so rigidly that there was no inducement to builders to enter upon speculation. Added to these was the masons' and bricklayers' strike which delayed work already in progress, enhanced the cost of building and frightened off investors who might have had work under consideration.

The lumber trade of Toronto has depended largely upon the extension of house building. Large public works such as Court House, Parliament Buildings, Board of Trade, &c., use up comparatively little lumber or timber and do not materially affect the lumber trade in any way.

That the past has been a slow year is evidenced by the number of failures that have taken place among small builders, who having been unable to sell their houses or carry them have had to unload upon their unfortunate creditors, the lumber dealer and the hardware man. During the year two well known wholesale firms have passed out of business under circumstances which have led many saw-millers to mourn the instability of the credit system.

In Western Ontario the spring opened up with but a dull demand, owing to the large stocks on hand in the yards after a winter of bad weather, bad roads and consequently slow collections and no sales.

During the summer and fall, however, an active business was done, and it may be said of this branch of the trade, in which Toronto dealers are largely interested, that it is in a fairly healthy condition.

The South American trade was completely blockaded by the political and financial convulsions in Brazil and the Argentine Republic, and this hitherto profitable branch of the business seems likely to remain in a state of stagnation for some time to come.

The scarcity of cars during the year 1890 was one of the crying evils of the trade. The lumber section of the Board of Trade took the matter up, and backed by the council of the Board of Trade and the leading lumber manufacturers, pressed their claims for redress against the Grand Trunk Railway Co. so vigorously that the management of that road made earnest endeavors to meet the difficulty.

The unexpected development of the ice traffic, the double track construction, and the shortage of engine power are all blamed for the scanty supply of cars. Added to this the needless and vexatious delays of shipments in transit made the lumber dealer's business life anything but a happy one.

After many interviews the Grand Trunk Railway Co., for the purpose of encouraging and facilitating winter shipments of lumber, have conceded a 3000 lb. allowance on flat cars instead of 2000 lbs. as formerly, and have given reduced winter rates on shipments to Western Ontario and the United States.

By the passage of the McKinley bill the tariff on sawn pine lumber was reduced to \$1.00 per M feet, and this combined with low freight rates should enable lumbermen to move off during the winter a consider-

able quantity of stock which heretofore has been held over until the opening of navigation.

The stock of logs put into the mills last winter was considerably short of previous seasons and as a consequence prices were pretty well maintained during the year. Bill stuff has if anything been slightly advanced especially on the lengths over 18 ft. In the fall, just before the close of navigation, there was an active demand from the U. S. for good lumber which for nearly a year had been a drug in the market. All kinds of hardwood have been in fair demand and prices are firm at the published quotations.

The stock that is being carried over is comparatively light. The Georgian Bay mills were pretty well shipped out before the close of navigation, and at rail points there is no large surplus of lumber on hand.

The present has been, speaking generally, a favourable winter for getting out logs, and there is every prospect of a full average cut for next season.

It does not seem probable that the local trade next season will be very much of an improvement upon the year 1890, and although the business atmosphere should be clear after the demise of a large number of weak houses, yet discreet business men will hold in credit with a firm hand and buy with caution.

There is nothing in prospect that will warrant the spreading of sail during the coming season.

Indiscriminate selling to weak buyers on long terms of credit have been the ruin of many lumber houses in Toronto in the past and it will be well if the survivors will take heed to the lesson.

Ottawa exchanges and correspondents report great activity in rail shipments both on the C.P.R. and C.A. division of the G.T.R. Most of the shipments are billed for the U.S. and it is presumed that an impetus has been given to the Chaudiere trade by the reduction of \$1 per M in the import tariff of that country.

The past year on the whole is looked upon by the manufacturers and shippers as exceedingly dull and its effect will be marked on the cut of logs for the winter.

Some limits are being operated with as large gangs of men as last year, others have reduced the number, while quite a few are reported as doing nothing.

J. B. Snowball, of Chatham, N.B., has published his annual timber trade circular. It is reliable. Nova Scotia exceeded her output for 1890 by 7,000,000 ft., New Brunswick decreased hers by 63,000,000 ft.

PORTS.	1889.	1890.
Miramichi .....	109,669,913	87,633,256
St. John .....	180,167,488	132,608,516
Bathurst .....	15,578,454	10,204,103
Dalhousie .....	23,502,348	22,114,275
Richibuctoo .....	13,084,798	14,915,707
Shediac .....	12,176,273	11,780,071
Sackville .....	14,852,000	14,174,000
Totals .....	369,031,274	293,364,928

Tons timber 93,329 in 1889 and 6,229 in 1890. The trans-Atlantic shipments from the province of New Brunswick for the past ten years were:

1881.....	394	Millions.
1882.....	376	"
1883.....	411	"
1884.....	333	"
1885.....	292	"
1886.....	276	"
1887.....	250	"
1888.....	277	"
1889.....	369	"
1890.....	293	"

The shipments of deals from Nova Scotia to trans-Atlantic ports have been as follows:

1882.....	88,752,000	feet.
1883.....	77,918,000	"
1884.....	69,159,000	"
1885.....	79,647,765	"
1886.....	87,280,125	"
1887.....	82,959,589	"
1888.....	85,070,005	"
1889.....	92,605,488	"
1890.....	99,512,924	"

The Nova Scotia shipments were from the following ports:

	No. Vessels.	Tons.	Sup. Feet.
Amherst outports.....	46	25,478	18,131,900
Halifax .....	81	40,595	35,278,875
Jordan River.....	1	644	566,233
Parrsboro.....	41	35,958	32,560,186
Pictou.....	10	6,120	2,104,000
St. Margaret's Bay.....	7	2,963	2,769,937
Sheet Harbor.....	11	6,257	5,507,572
Ship Harbor.....	1	725	665,507
St. Mary's River.....	4	1,551	1,380,043
Yarmouth.....	1	590	542,611
Totals.....	203	120,890	39,512,924

Nova Scotia also exported 4,608 tons of birch timber, viz: 1,172 tons from Halifax, and 3,496 tons from Pictou.

The cause of the decline in New Brunswick exports was the sluggish United Kingdom markets and the low prices offered.

The cut of logs this winter so far is less than the corresponding time for 1890, and no doubt the fact that from 15,000,000 to 20,000,000 feet of deals was carried over influenced the logger when the winter opened.

Moving westward the Keewatin District demands some attention. The three centres of the lumber trade sawed a total of 60,000,000 feet. Norman cut 24,000,000 feet, Keewatin 21,750,000 and Rat Portage 15,550,000. Trade was active all the year.

Winnipeg did considerable with small mills, all the cut being used for local consumption. Several sections postponed building public and private buildings because lumber could not be secured.

If the Keewatin district does not make an effort to get hold of a slice of this trade British Columbia will cater for it and get it.

The new year's issue of the Vancouver *Telegram* and the New Westminster *Columbian* each devoted considerable space describing the industries of the country.

Boiled down, the state of trade for 1890 was that invested capital in lumbering doubled itself during the year. Attention has been drawn from Eastern Canada and some of the United States to the British Columbia woods admirably suited for interior decoration. The Royal City Planing Mills Co. shipped 325 carloads of Douglas fir to the Barney & Smith Car Mfg. Co., of Dayton, Ohio, in addition to smaller quantities. The mill doubled its output during 1888 and 1889 and increased it 30 per cent. over 1889 in 1890. The cut for the year being 20,000,000 feet of lumber 15,000,000 shingles and 5,000,000 lath.

Two new mills were built, the North Pacific Lumbering Co. (McLaren, Ross & Co.) at Barnett, capacity 100,000 ft. daily and the Mechanic's Mill Co. which cost \$35,000,000, and when in full blast will employ 600 men. The Brunette Saw Mills Co. spent \$90,000 on their mill. The Moodyville Saw Mill Co. was thoroughly overhauled and repaired. Hastings Saw Mill was largely rebuilt, and its capacity doubled. Both the Vancouver Lumber Co.'s mill and the Fader Bros.' mill have been placed on a sound financial basis, considerably extended and repaired, and are doing a prosperous business. Cassidy's sash and door factory, and Slater's shingle mill, the Manufacturing and Trading Co., and Morse & Boggs, have each been doing a good business. The Manufacturing and Trading Co.'s business is one of the industries belonging to the past year, and enters into the manufacture of furniture, cooperage and a general line of the manufacture of woods.

The lumber mills alone would suffice to make Westminster a town of great importance, and, consequently the growth of these establishments means growth to the city. The present combined possible output of the mills is over 500,000 feet daily, and an enterprise has lately been successfully floated for the erection of another large mill in the east end, which, when completed, will give a total capacity of about 750,000 feet daily.

Since the above was written the London, Eng. *Timber* has come to hand. It contains a long report on the state of Quebec and the lower provincial lumber trade. It is so full of items of interest that we publish it in full.

FOREIGN.

THE QUEBEC SEASON—The Canadian imports having closed, we propose to glance rapidly at the leading features in connection therewith during the past year. The result generally has been unsatisfactory for both sellers and buyers, and the season has probably been the most uncertain and disastrous one to shippers and importers for many years. The early part of 1890 found sellers with very firm ideas, and high figures in particular were quoted for any prime shipments of pine and oak. Freights opened steadily on the basis of 60s per std. for deals and boards, at which a fair amount of tonnage was booked. The annual visit of Quebec merchants did not result in anything like the usual amount of forward contracting, a general feeling being predominant, that prices were too high, and would either become easier, or that it would be impossible to re-sell purchases with any reasonable margin of profit. The business transacted consisted principally of small special lines, or particular and exceptional averages and sizes of timber and deals, for which high prices were undoubtedly paid. The demand for red pine deals was active, and a few contracts were placed at good figures. It soon became evident that an enormous stock had been got out, and was being manufactured on the other side, and that lumbermen, of all sorts and conditions, were vying with each other to secure the golden harvest, which a large margin on existing inflated figures seemed to have in store for them. We know for certainty now, that several years prior to 1890, left enormous profits to owners of Canadian timber limits, and large sums of money were made, especially among those connected with any form



of the pine industry. As the year wore on, owing to the accession of so much steam tonnage, freights began to fall, but few, if any, of those engaged in the trade, anticipated at the time, that they would recede to 36s 3d before the end of the year. The early summer brought vividly to light the financial weakness of several Quebec exporting houses, and the immense responsibilities they would be compelled to face, in the form of a falling market, and the burden of large and accumulating stocks. Some relief to the business difficulties of Messrs. Smith, Wade & Co., Messrs. J. S. Murphy & Co., and the unfortunate Davies complications, was found in the arrival of numerous sailing vessels at Quebec, ready and willing to accept almost any freights that could be secured. From this time forward, until the close of the season, numerous vessels were chartered by shippers, and extensive consignments of almost every kind of Quebec woods sent forward to various British ports, the larger quantity coming to Liverpool. Of these, the principal feature has been the largely increased quantities of birch, much exceeding anything we have received for many years. The quality generally was good, and the various parcels received were sold at so low a figure, as to compete successfully with other ports which have long held supremacy, mainly on account of cheaper values. Ash has also been freely consigned, and reduced prices helped the consumption a little. This wood, however, having gone largely out of use, owing to the greater adoption of walnut and oak, we are left with a large stock and the poorest possible demand. Elm has come forward in moderate quantities, the quality has been neither so clean nor fresh as usual, and the wintering stock is large. While this new movement possibly did much to slacken the financial tension of Quebec, it caused a heavy decline in selling values here. It also left early summer importers, who had failed to sell their holdings at a profit ex quay, in the unpleasant position of having to contemplate disastrous losses ex yard. The bulk of the autumn log arrivals were handled by Messrs. Holme, Wainwright & Co., who promptly distributed nearly the whole among firms in the trade, at the best available, but greatly reduced prices. The weakest feature in this connection was seen when some of these were re-distributed several times over, to other merchants, with little or no apparent profit on each individual transaction. The heaviest decline will be found in oak and waney pine, both of which have fallen from 6d to 9d per ft., according to quality and average. The drop in pine deals and boards, red pine and spruce deals is fairly represented by the reduction in freights. As ship owners will not be able to entertain, for some time at least, the present unremunerative rates, the position of all these articles may slightly improve during the next few months, although the stock is exceedingly heavy and much will depend upon the spring demand. Apart from the losses sustained by shrinkage in prices, it must not be forgotten that the wintering stock in Quebec is a heavy one, and that there are several uncomfortable items in the returns just issued as to what is being held here. For instance, we possess at the present time about 350,000 feet of oak logs, including, of course, Canadian and United States wood. Owing to the enormously increased arrivals and demand for the United States planks and dimensioned scantlings, the ordinary consumption of logs is rapidly falling away, probably never to return. The existing stock of logs is therefore out of all proportion to any probable real requirements, and must inevitably remain a drug if importation continue at anything like the figures of last year. The same influence is also at work with respect to waney and square board pine, the stock of which is now nearly 650,000 ft. Canada and the United States are sending such enormous quantities of cut up stuff, in the shape of pine deals, boards, sidings and scantlings that the former demand for logs must inevitably grow less and less, and the old condition of things, as regards the export log trade of Quebec be greatly changed. One has only to visit regularly the discharging berths of well known and almost weekly trading steamers to notice what is quickly taking place in the form and nature of imports. Special dimensions in every useful thickness, of excellent quality and manufacture, may be observed in many new descriptions of woods. Buyers are also being supplied with their exact lengths, widths and thicknesses, and deliveries made, not only at stated intervals throughout the year, but from numerous ports which had no shipping existence for such goods within the past year or two. These are factors which are fully apparent to all on this side and should be carefully considered by every seller and exporter in the vast Canadian timber trade.

**NEW BRUNSWICK TRADE**—At the commencement of the year freights were moderately high, with a firm tendency. Buyers, who had contracted for spruce deals the previous season, on f.o.b. terms, and had suffered through stiff advances during the latter months of 1889, began to buy largely, for the new season's supplies, on c.i.f. terms, and a fair all round business was done at good prices. Few of the early spring shipments had arrived before the downward tendency of the freight market began to manifest itself, and it was

not long ere sellers found it impossible to place their imports at anything approaching a profit. Spruce deal prices fell rapidly directly the first pressure of supplies was felt. St. John cargoes soon failed to realize the low value of £6 10s per standard, and many large shipments were yarded, either failing buyers, or in the effort to prevent a further decline. With a reduction in freights to the unprecedented figure of 35s per standard, the lowest point touched at the close of the year, and a fine cargo of Dalhousie deals was sold at £5 15s, the boards only realizing £5 per standard, in both cases ex quay, and thus free from any landing charges. Although the demand has been fairly steady until the last two months, most sellers have done badly, especially those who contracted early at c.i.f. prices. The high values and pleasant profits of 1889 have not only entirely disappeared, but resulted in a re-action, leaving the market in a low and weak state as regards prices, and the large stock of nearly 22,000 standards. As this does not include the additional quantities held by Liverpool firms at other West Coast ports, it is evident that the season has closed with possibly the largest stock on record. In its entirety it is probably one of the worst seasons experienced by the trade for years. Very few cargoes have been sold by auction, and the spruce deal business has settled down to one of private treaty. Until the present stock assumes a much healthier appearance and the demand again rises to a higher level, it will be worse than folly for shippers to consign market cargoes here, unless they are satisfied to do so at a heavy loss to themselves. Spruce boards have been in active demand throughout the year, owing, principally, to the requirements of ship canal contractors, and prices have been relatively good. St. John birch logs have come forward in reasonable and well arranged deliveries. The great bulk have been handled by Messrs. A. F. and D. Mackay in a most satisfactory manner to all concerned. The market has been steadily controlled, and a profitable outlet found for shipments in most cases on arrival. The existing stock is 86,000 feet; but with a regular consumption of nearly half this amount the position is a sound one. The import of Halifax and Prince Edward Island wood has been moderate, the quality excellent, and the bulk of arrivals have promptly found buyers at firm values. A large shipment of Satamagouche wood should have arrived last month for Messrs. Ellison, Murphy & Co. and is now so much overdue that fears are entertained as to the safety of the vessel. St. John and Lower Port birch planks have been sent forward in enormous quantities without the slightest regard to consumption. In face of these facts values have fallen much below anything that could have been anticipated, and far beyond the difference represented by the decline in freights. Towards the end of the year several parcels changed hands on the basis of about £6 per standard, but prices have since somewhat improved. The stock remains heavy, but thanks to an excellent demand in November and December it has got down to 164,000 feet and it appears likely that sellers will shortly obtain improved figures on their holdings. Several parcels of St. John pine timber have been imported, and the last consignment of the year is on the quay ex *Nettie Murphy*. It has mostly been prime, fresh wood of excellent quality and has been so far rapidly passed into consumption, as usual, by Messrs. Holme, Wainwright & Co., who have generally handled the whole of these shipments which have proved so useful for the best machine purposes.

**PITCH PINE TRADE**—The general consumption has been large, and sawn wood general in demand. The enormous requirements of the ship canal contractor have been steady and continuous for the past two years, and from any reliable information obtained, seems likely to remain so for some time to come. The season opened with a light stock especially in hewn wood. Prices were satisfactory to sellers and buyers, and, with anticipated excellent demand, the prospect was bright. The sudden arrivals of several steamer cargoes of sawn wood, which were promptly offered by auction on shippers' account, began to weaken the market. For a time, owing to the uneasy feeling created by the knowledge that further supplies were on the way, it was impossible to dispose of fresh arrivals except by this method. Values were quickly forced down 2d to 3d per ft., and large sales were made by dealers for medium sizes at 12½d to 13½d per foot. This left little or no margin of profit on the most favorable purchases, and any competitive business continued in this unsatisfactory state nearly the whole of the year. The decline in the import and a large consumption brought about considerable improvement during the last three months, and the stock is a satisfactory one, being only 417,000 ft. Hewn timber, which was leaving an excellent profit to importers in the early months soon became a glut, and the excellent results it was yielding rapidly vanished. The demand considerably abated and was reduced last month to 15,000 ft. With the excessive stock of 534,000 ft., hopes of improvement are more or less remote, and the present holdings must remain a drug for some considerable period of this year. Special sized logs in both hewn and sawn wood have

left better results and helped materially to improve the returns on any large averaged cargoes. Particular shipments, such as very prime consignments of the Sullivan Timber Co., have done better and yielded 2s to 3s per load over ordinary prices. Much of the consignment timber, especially in sawn wood, has been of a middling to inferior character. Many contracts have been fulfilled with too large a portion of sappy logs, and in the inevitable arbitrations which have followed large awards have been made to buyers for this defect. The principal feature of the year has been seen in the extended importation of sawn boards in many new sizes. These are now being manufactured not only in the usual narrow widths, for ordinary flooring purposes, but also in a variety of dimensions up to 16 in. wide, and suitable for the many wants of retail dealers. Several parcels lately arrived have been of exceedingly clean and prime quality, perfectly free from sap on the face side, and of highly improved sawing and general condition. In sympathy with the movement in other directions, pitch pine must ere long witness the same transition already extended more largely to other woods. Some large contracts have been made for these particular sizes, for the coming season and if shippers will faithfully carry out their promises and pay due regard to their culling, an increasing demand for such useful goods will become permanently established. The total stock in the port at the close of the year was rather over 1,000,000 ft., which is exclusive of that held by local firms having depots at other West Coast places.

#### UNITED STATES.

Just as we go to press a heavy fall of snow is reported from Northern Wisconsin and the lake Superior countries. This means thousands of dollars to the lumbering interests, the lack of snow having caused great inactivity.

Still, the open winter during December and January, and the absence of snow will have an influence on prices. Cutting logs ceased in many sections during the month, the logger being afraid that those on the skids would never reach the streams, no snow being in the woods.

The usual number of salesmen have not been on the road either in the east, the west or north-west, and the retail lumbermen of no less than a dozen states have indulged in gatherings during the month, in most cases revising their price lists and shoving up quotations. On the whole 1891 looks rosy.

The quietness existing during the holiday season still prevades the markets of the United States in which Canadian lumbermen have special interest. At Boston the bulk of orders booked are for spring deliveries, and the turn over of stocks in the yards and wharfs exceedingly inactive. Trade has fallen off somewhat since our last reports.

Freights from Gulf ports, and the Atlantic coast to the south, are lower than they have been for years, and many vessels have tied up sooner than accept the rate offered.

The market is glutted and the car lot receipts for January exceeded the demand.

As spring approaches the conditions will change and dealers confidently assert that the outlook is promising.

In Albany, N. Y., the weather during January was too severe to allow building operations to be carried on with any degree of comfort or at a profit. The local demand was constantly light. Dealers are enquiring after purchases for the coming season and report Canadian stocks, especially at Ottawa, stiff, quotations having advanced \$1.00 per M on all grades of pine.

Complaints were rife at the close of the year and during stock taking, amongst lumber dealers in Buffalo and Oswego, about the hard season's business. Statistics for the year as far as receipts and shipments are concerned, contradict the grumbling. If trade has been individually unsatisfactory, dealers must have sold at a small margin or a loss. They cannot attribute losses to a lack of trade, for Buffalo has never made such a good showing in volume as she made in 1890, and Oswego held her own with former years. Buffalo is increasing rapidly in population. Contracts for building requiring large quantities of lumber are let for the coming season, and the local trade as a consequence will be brisk. Stocks are not heavy and buyers are feeling the Pennsylvania, New York, and Canadian manufacturers.

Tonawanda has taken things complacently during the month, buying nothing except when compelled to fill particular orders. Prospects seem fair and developments must certainly fulfill the expectations of the best posted dealers, who believe that the present quietness is but a natural feature of the trade.

Canadian lumbermen and vessel men will be delighted to hear that the government has decided to remove the obstructions to navigation in the Niagara River at the inlet pier and at Strawberry Island. A contract has been let for the removal of the rocks at those places, and when the work will be completed the channel will be 18 feet deep, instead of 12½, as it now is. The obstructions have been responsible for a good many wrecks in the river, and the removal will be a great benefit to navigation. It will allow vessels to come to port with full loads that last year were compelled to lighten part of their cargoes in order to pass over the rocks.

**WANTED AND FOR SALE.**

Advertisements will be inserted in this department at the rate of 15 cents per line each insertion. When four or more consecutive insertions are ordered a discount of 25 per cent. will be allowed. This notice shows the width of the line, and is set in Nonpareil type. Advertisements must be received not later than the 27th of each month to insure insertion in the following issue.

**HARDWOOD** lumber, bought, sold or received on consignment, **TUCKER DAVID**, lumber commission merchant, 202 Eleventh Ave., N.Y.

**WANTED—TO BUY.**

**GOOD** Canadian Timber Limits and Georgian Bay saw logs. Address, **BEN BIRDSALL**, Whitney Building, Detroit, Mich.

**CAPITAL WANTED.**

**WANTED** A partner with about \$12,000 capital, to take half interest in a well established lumber and shingle business in British Columbia. Timber Limits now secured to run mill 5 to 7 years. For particulars address, **H. H. S., BOX 297, Vancouver, B. C.**

**WANTED—PARTNER**

**WITH** \$50,000 to \$75,000 capital to invest in timber limit and saw mills on line of C.P.R. in British Columbia, with three practical men. Best thing on line of C.P.R. Address **BOX 276, Trenton, Ont., Canada.**

**TAMARACK TIMBER.**

**THE UNDERSIGNED** wishes to purchase a large quantity of Tamarack Logs, from 8 to 20 feet long, the smallest to be not less than 13 in. at the top. A good price will be paid, delivered at Shelburne, Melancthon, Corbetton and River-view mills. **A. F. SPEARING**, Shelburne or River-view.

**FOR SALE** in the village of South River,—a first-class saw and shingle mill, in good running order: situated on the bank of South river, Farry Sound district. For particulars apply to **C. W. Burns, jr., South River, Ont.**

**FOR SALE**—Steam saw mill and bush lot in the township of Egremont. Apply to **Adam Watson, Durham.**

**MUST BE SOLD** at any sacrifice, heavy saw-mill machinery; first-class site: good stock of logs, and 200 acres of land; at junction of G.T.R. with C.P.R. Apply **E. GARROW**, Nipissing Junction P.O., Ont.

**WANTED IN 1891.**

**ANY QUANTITY OF CEDAR TELEGRAPH POLES** at shipping points. Terms cash. Apply to **J. HARRISON HARVEY**, Cobonk, Ont., purchaser for **H. D. McCAFFREY**, Engineer and Contractor of Telegraph lines, Oswego, N.Y.

**FOR SALE.**

**PAIR TWIN ENGINES**, 6x6, with link motion, suitable for rope feed, in order, **J. HADDON**, Foxmead Ont.

**PARTNER WANTED** in a Steam Saw Mill; good location; abundant supply of logs to purchase or saw by the M. Capacity with circular 25 to 30 M daily, which can be increased to 50 or 60 M by addition of gang, for which mill is suitable. Capital required to invest, sawing by the M, not over \$5,000. Man capable of taking full control of the business preferred. Address **PARTNER**, care of CANADA LUMBERMAN.

**WANTED—FOR CASH—HARDWOOD**

**HARDWOOD** Lumber Squares and Dimension Stock, principally wa'nut squares, 1 1/2 to 7 in. thick 12 in. and upward long. Apply for specifications and prices. State full particulars of stock on hand. **P. O. BOX 1,144, New York.**

**RAILS AND CARS FOR SALE.**

Light Steel Rails for Tramways; good order. Cars for lumber, cheap.

**JOHN J. GARTSHORE**,  
49 Front St. West,  
Toronto.

**WANTED.**

**QUEBEC BIRCH**—Those who can furnish choice lumber are invited to correspond with **JOHN S. MASON & CO.**,  
240 Eleventh Avenue,  
New York City.

*Pine Timber Limits*  
**FOR SALE**

On Upper Ottawa running back from Birch Lake. Main Ottawa river. 300 miles—selected years ago—well timbered, good streams for driving. Terms of payment easy.

Apply to  
**J. BELL FORSYTH & CO.**  
QUEBEC.

**TIMBER \* LANDS FOR SALE**

**5000 Acres of Timber Lands on the Manitoulin Island,**

Patented and unpatented, are offered at the Low Price of  
**\$5.00 PER ACRE.**

Some of the lots have timber on them worth \$20 per acre, and the land is of fair quality for farming when cleared.

The Dominion Government having recently taken off the Export Duty on Telegraph Poles, Railway Ties, Shingle Bolts and Saw Logs, the value of the timber on the Island is doubled, owing to its great facilities for shipment to Detroit, Chicago, Toledo, Buffalo, Cleveland and all Lake ports.

The late owners, Messrs. Wm. and Robert Henry, are both deceased, and there being no one to carry on their business, these lands will be sold low, in Block to close out the estate. Tenders solicited and purchases liberally dealt with. All necessary information can be obtained from the trustee and Solicitors,

Messrs. **FRANCIS & WARDROP**,  
Barristers, &c.,  
**JAMES MCGEE**, Trustee,  
Toronto.

**PROTECT your MILLS**

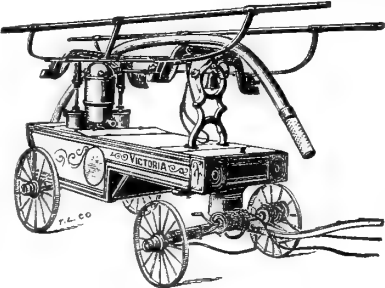

**GIANT HAND FIRE ENGINES.**  
From \$200 to \$700

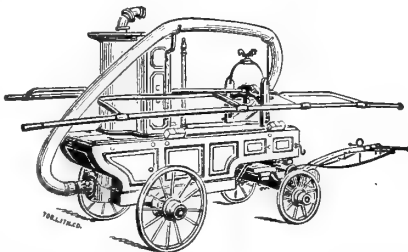

**800 Feet Second-Hand 2 in. Fire Hose Cheap.**

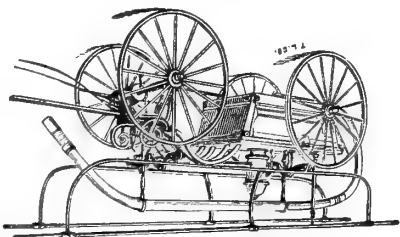

**Waterous Engine Works Co.,**  
Brantford, Canada.



**COWPER & GREGORY.**

**RECEIVERS** and Forwarders of Lumber, Lath, Shingles, &c. Unexcelled facilities for shipping by canal or rail. Tonawanda, N. Y.

**A. M. DODGE & CO.**

**MANUFACTURERS** of and Wholesale dealers in all kinds of Lumber, Lath and Shingles. Tonawanda, N. Y.

**E. & B. HOLMES.**

**WHOLESALE** dealers in Lumber and Timber. Office, Michigan and Canal Streets, Buffalo, N. Y.

**CHEESMAN DODGE**

**TIMBER** and Lumber Merchants. Ship and Boat stock, Railroad Ties, &c. Office, 16 West Seneca Street, Buffalo.

**Buffalo Hardwood Lumber Co.**

**OFFICE** and yard, 175 Louisiana Street, Buffalo. Holders of Hardwood stocks are invited to correspond.

**EMMET FLEMING**

**INSPECTOR** and Commission dealer in Lumber. Office, 251 Louisiana Street, Buffalo, N. Y.

**LAYCOCK LUMBER CO.**

**MANUFACTURERS** of Pine, Hemlock and Oak Timber up to 35 feet in length. Saw Mills: Ackley, Pa., Black Rock, N. Y., Gravenhurst, Ont. Office, corner Main and Seneca Sts, Buffalo, N. Y.

**J. & T. CHARLTON**

**WHOLESALE** dealers in Masts and Spars, Canada Round Pine, &c. Tonawanda, N. Y.

**WILLARD W. BROWN.**

**202** Main Street, Buffalo, handles all kinds of Hard Woods.

**A. P. & W. E. KELLEY CO.**

**WHOLESALE** Lumber dealers. Yards at Tonawanda and Chicago. Correspondence invited.

**C. P. HAZARD.**

**WHOLESALE** dealer in Lumber, Shingles, Lath and Fence Posts. Correspondence invited from the Canadian trade. No 92 River Street, Buffalo, N. Y.

**L. A. KELSEY LUMBER CO., (Ltd.)**

**MANUFACTURERS** and dealers in Hardwood Lumber of all kinds. Describe stock and write for prices. Office Tonawanda, N. Y.

**BOVEE & HOWDEN**

**MANUFACTURERS** and Wholesale dealers in Hard and Soft Wood Lumber. Holders of Canadian stocks are invited to write for quotations. Offices at Tonawanda and Le Roy, N. Y.

**THE TONAWANDA LUMBER CO.**

**MILLS** at East Tawas, Mich.; office 106 Main Street, opposite N. Y. C. and H. R. R. Station, North Tonawanda, N. Y.

**J. J. TURNER,**

**Sail, Tent and Awning Maker.**

251 GEORGE AND 154 KING STREETS.

PETERBOROUGH.

Canoe, Yacht and Boat Sails made to order. Perfect Fits guaranteed.

Every description of Lumbermen's Supplies and Waterproof Clothing.

**Fawcett & Co.**

**MERCHANT \* TAILORS,**

269 Queen St. E., Opp. Seaton St., Toronto.

First-Class Goods and Trimmings. Workmanship and Fit Guaranteed. All Orders Punctually Executed.

HERBERT G. ROSS. Box 273. REGINALD C. BLAKER

**H. G. ROSS & CO.**

*Real Estate, Fire and Life Insurance, Shipping and General Commission Agents.*

Timber Limits and Farming Lands a Specialty.

A.B.C. Code, Cable address, "Ross."

**NEW WESTMINSTER. - - B. C.**

CORRESPONDENCE SOLICITED.

**The American Lumber Yard HAMBURG, GERMANY,**

Offers the best facilities for Yarding and Selling all kinds of

**American Wood Goods.**

Address :

**ROSENBACHER & CO.,** **CARL GARTNER, Agent,**  
BANKERS, Hamburg. Hamburg

**GEORGE McWILLIAMS**

(Successor to Wm. Forsyth.)

MANUFACTURER OF

**TAPER PIKE POLES,**

**PEEVEY STOCKS, CANT HOOK AND GAFF HOOK HANDLES.**

The only Successful Taper Pike Pole Manufactured.

Peterborough, = = Ontario.

GEO. HASTINGS.

JOHN GRAY.

H. HANCOCK.

# GEO. HASTINGS & CO.

## Lumber Merchants

TRUST BUILDING CHAMBERS,  
Cor. Yonge and Colborne Streets.

TORONTO.

All Kinds of Pine and Hardwood Lumber.

BILL STUFF CUT TO ORDER A SPECIALTY.

# TORONTO HARDWOOD LUMBER CO.

Wholesale Dealers and Shippers in all kinds of



83 Front Street West, Corner Lorne Street, - TORONTO.

OFFICES  
Hamilton, Toronto  
Windsor

TELEPHONE  
No. 1046

MILLS  
Gravenhurst, Huntsville  
Katrine.

# ROBERT THOMSON & CO.

DEALERS IN

## Pine and Hardwood



Mills Operating all the year round. Correspondence Solicited.

TORONTO OFFICE  
LONDON CANADIAN CHAMBERS 103 BAY STREET,

THOMAS MEANEY,  
REPRESENTATIVE.

TORONTO.

# DONOGH & OLIVER,

Wholesale Dealers in

# LUMBER

OFFICE:

Nos. 16 and 17 Imperial Bank Buildings,

WELLINGTON STREET EAST.

TORONTO, ONT.

DALTON McCARTHY, President.

J. H. EYER, Manager

# Toronto and Midland Mfg Co.

(INCORPORATED.)

# Wholesale \* Lumber \* Dealers

AND MANUFACTURERS OF

# DRESSED LUMBER, FLOORING

Ceiling, Sheeting, Siding, Shelving, Mouldings of all Descriptions.

Office and Yard:

FOOT OF SPADINA AVE., - TORONTO.

Planing Mills: MIDLAND, ONT.

# PORTER, ROBERTSON & CO.

STOCKS  
STRIPS  
SIDINGS  
BILLSTUFF

WHOLESALE

# LUMBER

DEALERS

HARDWOODS  
HEMLOCK  
SHINGLES  
LATH, ETC.

Millichamp's Buildings,

35 \* Adelaide \* Street \* East,  
TORONTO.

YARD: NORTHERN DOCK, FOOT OF BATHURST STREET.

Established 1849.

Incorporated 1884.

# Detroit Saw Works

MANUFACTURERS OF

# Circular, Gang, Mulay, Drag and Cross-Cut Saws.

MOLDING AND PLANING KNIVES,

We use nothing but W. J. & Sons' English Steel in our saws and the name speaks for itself.

French Band Saws, Emery Wheels and General Mill Supplies.

66, 68, 70 and 72 Fort St. East, DETROIT, MICH.





**AN IMPROVED SAW SWAGE.**

Palmiter, Empey & Co., of Galt, Ont., advertise in another column their new Improved Saw Swage. Without an exception their patrons express themselves as more than satisfied with its workings. If enquiries are the criteria of future sales the firm's capacity will be over-taxed.

**FIRES AND CASUALTIES.**

Recently, while Charles Robinson was working in his father's saw mill, in West Garafraxa, he was caught in the machinery with the usual result that one leg was broken and the ankle shattered.

The Joshua Jarvis, who was killed in an accident on the Vermont Central road, on which he was employed, worked last year in Eddy's pulp mill, Hull, Que.

A young man named John Linton, who was chopping wood in the McGladery camp at Birch & Linnett's bush, six miles from Fergus, was killed by a falling tree.

Mr. Laban Walter, son of Mr. Richard Walter, of East Wawanosh, met with an accident. He was taking out some saw logs from the swamp when a log fell on his leg, breaking one of the small bones and putting the ankle out of joint.

A fire in Aldred & Sons' Foundry, of Glencoe, made such headway before it was extinguished that \$8,000 loss was occasioned.

Hyacinthe Beaulier, working in the camp of Napoleon Charlebois, a foreman for the C. Beck Manufacturing Co., of Penetanguishene, lost his life in the township of Tiny, county Simcoe, by a tree falling on his head. He leaves a widow and six children.

Mr. William Hay, of Dornoch, has returned from Marquet, Mich., lumber woods. He having been injured while employed there. A younger brother has been so unfortunate as to cut off one of his great toes.

A man named Carruthers, who was in charge of Fotheringham's mill at Rat Portage, has been either murdered or committed suicide. He was found in his house with a bullet in his head, and it is said his wife was in the house at the time of the occurrence.

Richard Gregory, cabinet-maker, of Kingsville, was running a buzz saw, when his right hand came in contact with it and the points of two fingers are now missing and a third is badly cut.

Mr. H. B. Coward, Cardville, N. W. T., met with a very serious accident a week ago. Whilst carrying a log on his shoulder he tripped and fell, the log falling on his back, injuring him very severely. He has not been able to leave his bed since.

A man named Wentzel, belonging to New Canada, and working in the employ of Messrs. Davidson & Sons, Halifax, N. S., as a chopper in the woods, was seriously injured by a falling tree on Saturday last. Dr. Primrose was sent for and arrived at the camps on Saturday afternoon, and he pronounced the wounds of such a serious nature as to determine the unfortunate man not to be removed least fatal results might follow.

Patrick Mulvey of Vinton, Que., aged 29, employed in M. Shannon's shanty on Black River at log-cutting, received a wound in the knee from an ax used by his nephew (who was working with him), flying off the handle. The injured man was brought home from the woods, and on the way had the wound dressed, which it seems was not properly done, causing blood-poisoning. Three doctors decided that the leg would have to be taken off, but the sufferer would not agree to have this done, the consequence was that death resulted.

**Cash for Hardwood Lumber**

We are open to purchase all kinds of Hardwood Lumber. Cash F.O.B. cars. Write us for prices and sizes to cut.

W. N. McEachren & Co.,

No. 3 Dock. TORONTO.

# Do You Stop Your Saw

by lifting a tightner, throwing off the heavy belt, or stopping the engine ; All these methods are objectionable.

We have patented a Friction Grip Pulley. Compact, Simple, Durable, Large Frictional Area, Ample clearance when out of engagement, Powerful gripping mechanism.

We guarantee this Pulley to work satisfactorily, and to be thoroughly reliable.

Made Split when required. And with 2, 3, 4 and 6 grips for any class of work. Also a Cut-off Coupling of the same design.



SEND FOR CIRCULARS AND PRICES

## The Waterous Engine Works Co., Brantford, Canada

### NAPANEE CEMENT COMPANY (LIMITED.)

— MANUFACTURERS OF —

### Hydraulic Cement

PARTICULARLY adapted for Dams, Smoke Stacks, Foundations, Culverts, Cisterns, Cellars, etc.

ENDORSED BY LEADING RAILWAYS AND CONTRACTORS.

### ROACH \* LIME,

For Building, Plastering, Gas Purifying, Paper Making, &c.

### THE RATHBUN COMP'Y, DESERONTO, ONT.,

MANUFACTURERS OF

### \*TERRA \*COTTA \*FIRE-PROOFING \*

For Use in Old and New Buildings.

Endorsed by Leading Architects. Absolutely Fire-proof. About as Cheap as Wood or Brick. Weight One-Third that of Brick. Does not Crack on application of Heat or Water.

Deadens Noise. Gives Warmth in Winter; Coolness in Summer.

### Galt \* Machine \* Knife \* Works.



### MACHINE KNIVES

OF EVERY DESCRIPTION FOR

Planing, Moulding & Stave Cutting.

SEND FOR PRICE LIST

PETER HAY, - - - GALT, ONT.

## MILL MACHINERY

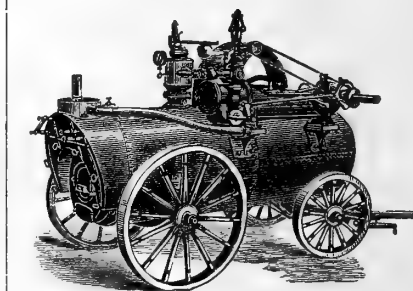
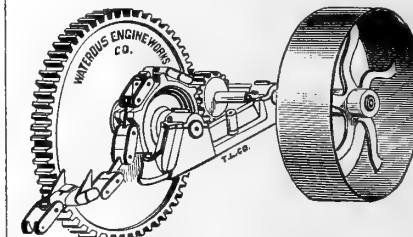
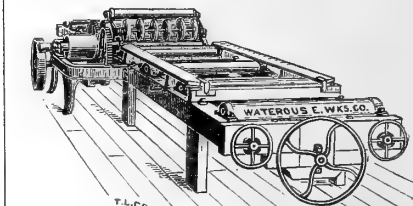
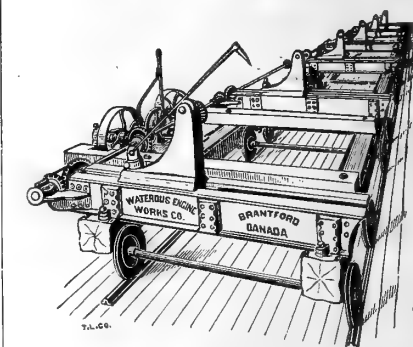
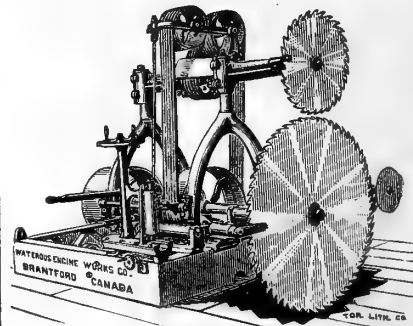
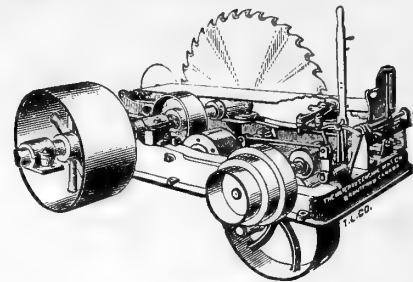

### Link Belting

Sawdust and Refuse Carriers. Line Rolls.



All products into, through, and out of mill.

Send for Catalogue and Prices.

**Waterous Engine Works Co.,  
Brantford, Canada.**

A. ALLAN, Pres.

J. O. GRAVEL, Sec-Treas.

F. SCHOLLES, Man. Director.

# Canadian Rubber Company OF MONTREAL.

SOLE AGENTS AND MANUFACTURERS

OF THE

## Forsyth (Boston Belting Co.,)

### Patent Seamless

# RUBBER BELTING

For the Dominion of Canada



----- Capital \$2,000,000. -----

### Our Rubber Belting is Unequaled in America.

All kinds of Rubber Packings, Rubber Engine, Hydrant, Suction, Steam, Brewers' and Fire Hose; Rubber Valves, Car Springs, &c., &c.

*Mould Goods of Every Description.*

Superior Quality Rubber Goods.

HEAD OFFICE AND FACTORY, MONTREAL, J. J. McGill, Manager.

WESTERN BRANCH:

## Corner Yonge and Front Streets, - TORONTO.

J. H. WALKER, Manager.

# Rhodes' Improved Swage for Circular and Gang Saws.

== PATENTED JULY 2, 1889. ==

THE MOST PERFECT MACHINE FOR THE PURPOSE EVER INTRODUCED.

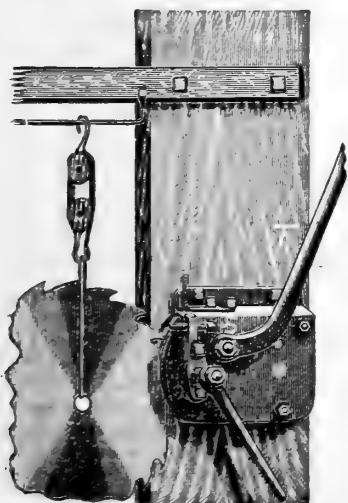

SWAGE IN OPERATION.

It will swage the hardest as well as the softest saws. Never pulls the points of the teeth off, as the swaging is done by direct and steady pressure, and not by rolling pressure.

Swaging done with this machine will stand longer than when swaged with any other machine or by hand.

It makes the swage the heaviest on the under side of the tooth, and leaves the face of the tooth perfectly straight.

It does not shorten the tooth as done by upsetting. It has a positive clamp so a saw cannot slip while being swaged, therefore every tooth is an exact duplicate of the other.

Corners never drop off if swaged with this machine, as it does not injure the steel, therefore the teeth can all be kept of a length.

It is very simply constructed; nothing to break or wear out. Easily adjusted. Any ordinary man can swage a circular saw in from 10 to 12 minutes. Is thoroughly constructed of the best material, all the parts requiring it are made of steel of the best quality. Every swage is thoroughly tested before leaving the shop.

We positively guarantee the swage to do all we claim for it in this circular.

Full and complete instructions for adjusting and operating accompany the swage.

SEND FOR PRICE LIST OF

RHODES' IMPROVED

Automatic Band Saw Swages, Circular Saw Swages, Gang Saw Swages, Shingle Saw Swages.

—MANUFACTURED EXCLUSIVELY BY—

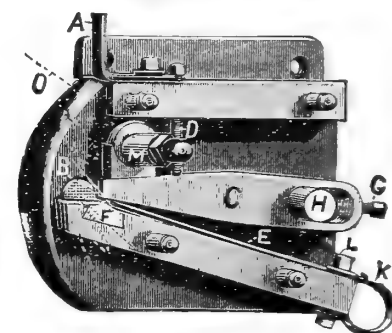

SECTIONAL VIEW.

P. O. BOX 430.

## Palmiter, Empey & Co., Galt, Ont.

Gold Medal, Toronto, 1883

# The Galt Bros. Co., Limited.

Gold Medal, London, 1883

Manufacturers of

Planers

Moulders

Tenoners

Shapers

Rip Saws

Band Saws

Band Re-Saws

Panel Raisers

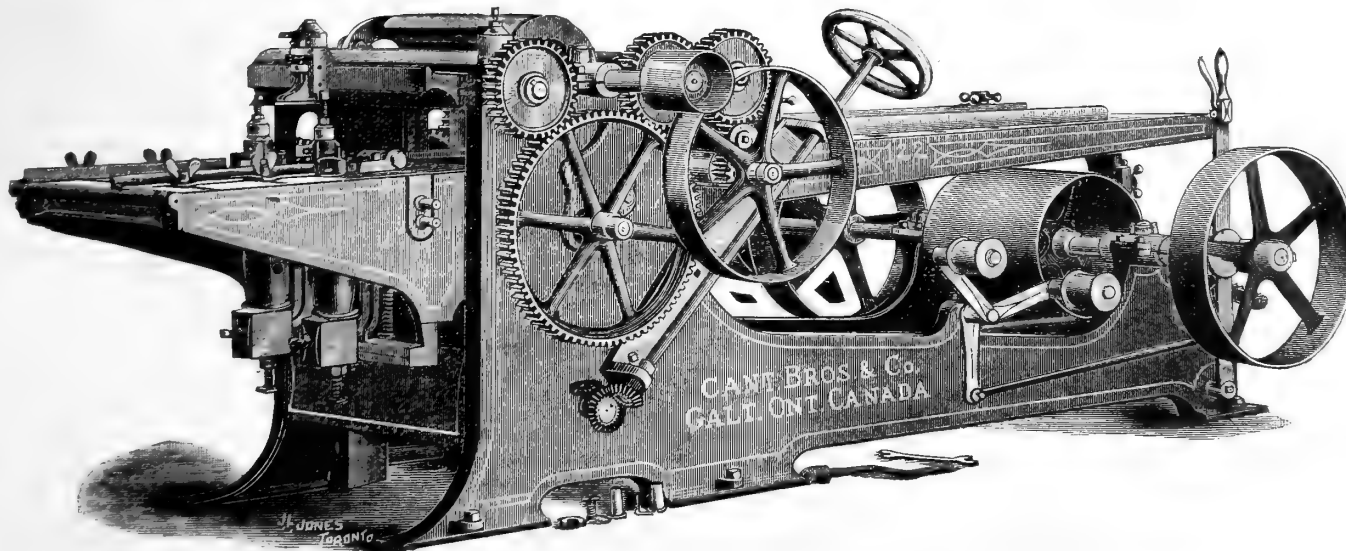

Manufacturers of

Swing Saws

Jointers

Buzz Planers

Morticers

Blind Machinery

Band Saw Filer

Band Saw Setter

Etc., Etc.

The "DEFIANCE" PLANER AND MATCHER for

Planing Mills, Sash Door and Furniture Factories.

Correspondence Solicited.

GALT, ONTARIO.

# The Only Successful Kiln for Drying Oak and other Hardwoods

**"THE ANDREWS"**

NEW LUMBER

## DRY-KILN

Its remarkable efficiency depends upon its peculiar mode of applying heat to, and eliminating moisture from, the air used in drying. We use no costly fan, engine or other device that requires constant attention, nor do we waste heat by a special chimney. The air circulates through the lumber, and the moisture absorbed from it is extracted from the air by natural methods. You can not afford to be without it.

Our Process Duplicates Nature.

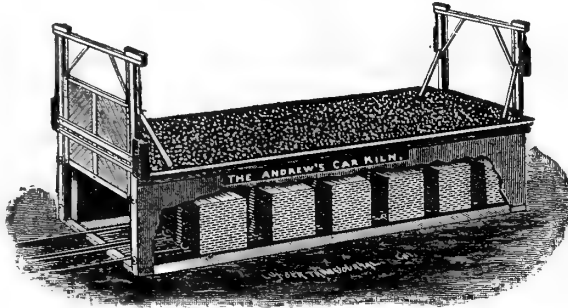

Outside View of the Andrews Kiln.

The following well-known furniture manufacturers have recently purchased the "ANDREWS KILN."

- Estey Manufacturing Co., - - - Owasa, Mich.
- East Shore Furniture Co., - - - Manistee, Mich.
- Universal Tripod Co., - - - Grand Rapids, Mich.
- Grand Rapids School Furniture Co., Grand Rapids, M.
- New England Furniture Co., - Grand Rapids, Mich.
- Milwaukee Chair Co., - - - Milwaukee, Wis.
- Oshkosh Furniture Co., - - - Oshkosh, Wis.
- Skandia Furniture Co., - - - Rockfork, Ill.
- Story & Clark Organ Co., - - - Chicago, Ill.
- Rock Falls Manufacturing Co., - - - Sterling, Ill.
- Courey & Birely Table Co., - - - Shelbyville, Ind.
- Southern Spring Bed Co., - - - Atlanta, Ga.
- Sidney School Furniture Co., - - - Sidney, Ohio.
- New Richmond Church Furniture Co., N. Richmond, O.

## A. N. Andrews & Co., Proprietors and Manufacturers

215, 217, 219, 221 Wabash Ave., CHICAGO, ILL.

## The Casselman Lumber Co.

CASSEMAN, ONT. Successors to FLATT & BRADLEY.

ESPECIAL GOOD FACILITIES FOR SHIPPING.

HEMLOCK BILL STUFF OF EXCELLENT QUALITY.

ALSO MANUFACTURERS OF

PINE, SPRUCE, ASH, MAPLE AND OTHER HARDWOODS.

CORRESPONDENCE SOLICITED.

J. W. MAITLAND  
H. RIXON

I. G. AINSLIE  
W. STODART

## Maitland, Rixon & Co.,

Owen Sound, Ont.

## Saw Millers and Lumber Dealers

All kinds of Building Material kept in stock.

WE MAKE A SPECIALTY OF

LONG BILL STUFF IN ROCK ELM, PINE, CEDAR AND HEMLOCK.

QUOTATIONS FURNISHED ON APPLICATION.

## F. J. DRAKE,

PATENTEE AND MANUFACTURER OF

## SAW, SHINGLE and LATH MACHINERY

Belleville, Ontario.

### DRAKE'S PATENT DAUNTLESS SHINGLE AND HEADING MACHINE

Capacity from 25,000 to 50,000 per day.

The frame of iron throughout, very heavy and rigid, strongly bolted and braced; carriage very light and strong, made of forged cast steel saw plate, running on steel ways or tracks; will take in a block 18 inches wide and 19 inches long, adjustable for 16 inch or 18 inch shingles.

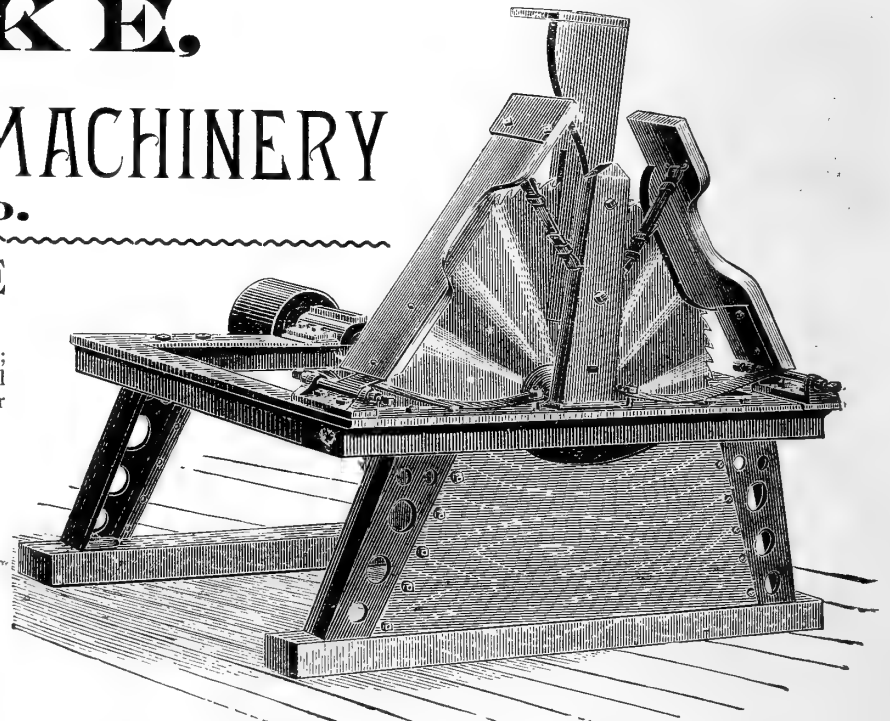
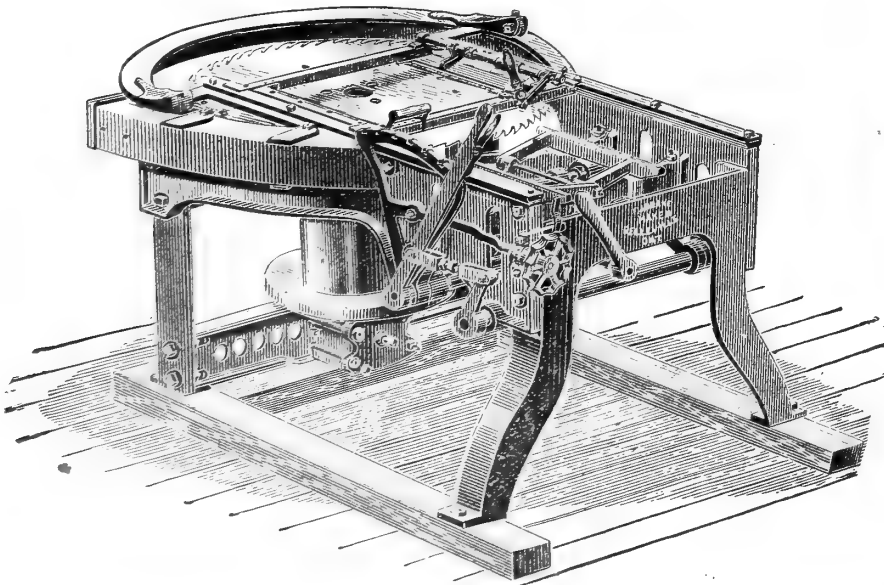

## Drake's Improved Shingle Edger.

With 40 inch saw will make more No. 1 Shingles from the same quantity of timber than any Wheel Jointer in existence.

It has a heavy iron frame made for two operators, two inch steel saw arbor, with extra long bearings; driving pulley 8 inches diameter, 7 inch face, saw 40 inches diameter, 16 gauge, speed, 1,600 per minute.

Mill men who have once used this machine will not use any other. For capacity, removing sap-knots, rot or any other imperfections, for making parallel shingles and economy of stock, it is superior to any other.

Also manufacturer of other kinds of Shingle Jointers, both self-acting and hand-feed Shingle Machines, Packing Boxes, Drag Saw Machines, Bolters, Stationary and Portable Saw Mills, Double Edgers, Single Edgers, Slab Saw Rigs, Bull Wheel Rigs, Lath Machines, Lath Bolters, in fact a general line of Mill Machinery, with Pulleys, Shafting, &c. Satisfaction guaranteed in all cases. Send for estimates on anything required, and the same will receive immediate attention.



# Friction Pulley Board.

The Best Materials ever used  
for Frictions of all  
\* kinds \*

MANUFACTURED BY

Asbestos  
Mill  
Board.

The **DOMINION LEATHER BOARD COMPANY,**  
Montreal, Quebec.

Steam  
Packing.

SAMPLES FURNISHED.

PLEASE MENTION THIS PAPER.

CORRESPONDENCE SOLICITED.

TO MILL OWNERS, MANUFACTURERS  
AND ALL WHO ARE USING

## Stop the Engine Instantly

*Leather \* Belting*

IF YOU WANT BELTING

*Which will Run Straight on the Pulleys,  
Which is Thoroughly Well Stretched,  
Which will not Tear at the Lace Holes,  
Which will give Complete Satisfaction,*

— SEND TO —

### F. E. DIXON & CO.

MANUFACTURERS OF

PATENT LAP-JOINT STAR RIVET

\*LEATHER \* BELTING\*

70 King Street East, Toronto.

Sole Agents in Canada for the

### CELEBRATED PHOENIX OIL

The Only Perfect Belt Dressing.

All our Belting is sold at the Canadian price list. Please compare before purchasing. Send for Discounts and our Pamphlet on Belting.

Unfortunately that is impossible, it is several stories below, therefore to stop this countershaft is a work of minutes.

#### The Accident

The stopping of the engine would have prevented or mitigated it; not an unusual one. Often it results in the loss of valuable life.

#### This Line Shaft

Could have been instantly disconnected from the power in any part of the room had it been driven with a Friction Grip Pulley.

## Will it not pay you

To investigate the merits of the newest and best Grip Pulley and Cut-off Coupling, "THE WATEROUS;" It is safe, economical in belts and time.

WATEROUS ENGINE WORKS CO., Ltd., Bantford, Canada.

## B. F. Sturtevant's Patent Progressive Lumber Dry Kiln.

RELIABLE RAPID! CHEAP!

GUARANTEED TO DRY

—IN—

Best Manner Possible

ALL KINDS OF  
HARD and SOFT  
WOOD LUMBER.

WRITE FOR CATALOGUE.

91 LIBERTY STREET  
NEW YORK.

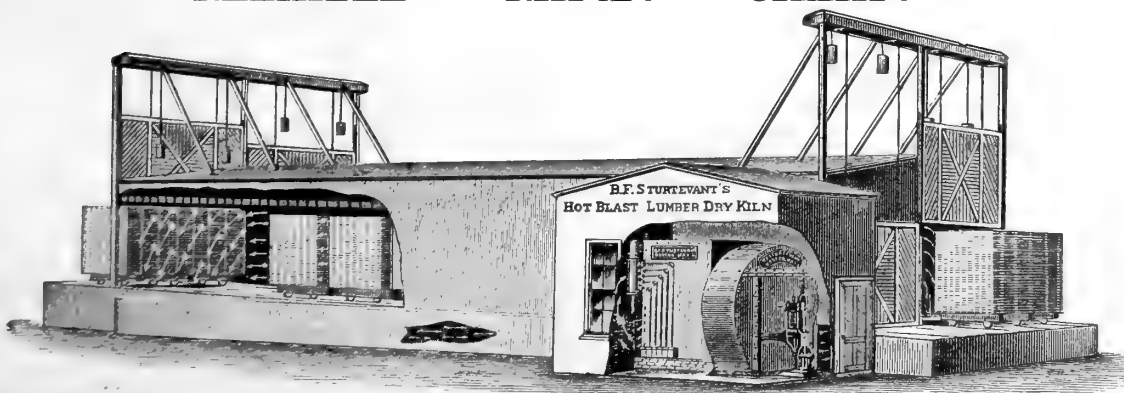

NO WARPING  
CHECKING  
AND BLUEING

—WITH THE—

STURTEVANT

Patent Hot Blast

Steam Heating

Apparatus.

31 N. CANAL STREET  
CHICAGO.

B. F. STURTEVANT, Patentee and Sole Manufacturer, 34 Oliver Street, (corner of Franklin street) BOSTON, MASS., U. S. A.  
A. R. Williams, Soho Machine Works, Toronto, General Agent for the Dominion.

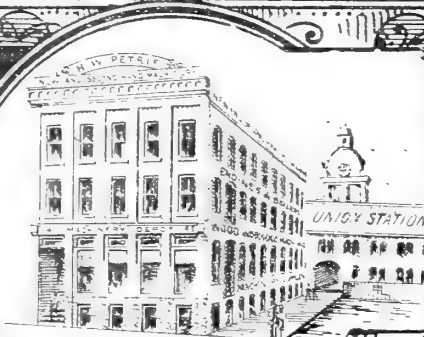

# PETRIE'S MACHINERY DEPOT.

Special Bargains  
this month.

HERE'S A CHANCE—And such a chance as comes but once in a lifetime. Having erected a large warehouse at Toronto, with a view of centralizing my business interests, I will sell for the next two or three months the stock of machinery and tools now stowed in my Brantford depot at reduced prices, in order to save cost of reshipment. Manufacturers and others who contemplate the purchase of machinery of any description whatsoever will find it greatly to their advantage to communicate with me without delay. The following list comprises only a very small portion of my stock:—

**NEW MACHINE TOOLS**—of Bertram & Sons' build—lathes, sharpeners, planes, drills, milling machines, bolt cutters, gear cutters, steam hammers, punch and shears, bending rolls, etc., etc.

**NO. 6 steel double exhaust fan**—Detroit Blower Co. make.

**SEVERAL** small size fans and blowers.

**ENGINES**—horizontal—following size cylinders—10x12, pair 8x7, 8x12, 8x12, 8½x14, 8x16, 8x16, 8x12, 8½x12, 8x10, 5½x14, 4½x7, 3½x7, 3½x11, 2½x8, 2½x5.

**UPRIGHT ENGINES** from 3 to 15 horse-power—full particulars on application.

**PORTABLE ENGINES** on wheels and skids from 3 to 20 horse-power.

**MARINE ENGINES** and boilers—3 to 18 horse-power.

**NEW steam yacht**—60 feet long and 9 feet beam. Send for full particulars.

**OSCILLATING ENGINE**—4½ x 8 inch—Beckett builder.

**ROTARY engines**—several sizes and makes.

**FINE** 100 horse-power boiler to build in brick—other sizes down to 2 horse-power.

**ONE** steam-heating plant—with radiators, etc. Full description on application.

**CONDENSER**—Waterous make—suitable for engine 100 horse-power.

**LARGE** stock feed water pumps, heaters, injectors, and engine governors—new and second-hand large stock.

**STEAM pumps**—several sizes and by different makers—also new of every size.

**HAND fire engine**—Seneca Falls build—a special bargain offered in this.

**FOUR** second-hand saw mills at very low price—one new 3-block mill, "Eclipse" make.

**LARGE** lot of lumber and log cars, drag saws, bull wheel rigs, edgers, butting saw rigs, and other saw mill requisites.

**18 SHINGLE** mills and jointers by different makers.

**TWO** Waterous self-feed lathe mills, and one bolter.

**TWO** stone cutters, 2-foot stone jointers, Greenwood bolter and equalizing saws.

**BAND SAWS**—36 inch wheel—also several small sizes, both new and second-hand.

**6 JIG** or scroll saws—from \$15 up.

**PLANERS** and matchers, surface planers, pony planers, buzz planers, etc.; large stock.

**MOULDERS**, shapers, tenoning machines, mortisers, boring machines, saw tables, blind machines, wood lathes, etc., in great variety.

**CIRCULAR** saws—from 72-inch down—saw arbours, a large assortment.

**LEATHER** and rubber belting, hose, lace leather, belt fasteners, etc.

**LARGE** lot of pulleys, fly-wheels, hangers, boxes, shafting, gearing, etc.

**WATER-WHEELS**—from 60-inch down to 10-inch diameter.

**GRIST MILL** machinery, "BUHR" stones, chopping mills, corn and cob mills, feed mills, smutters, centrifugal reels, elevators, stone dressers, etc.

FULL description in detail will be sent of any machine in above list, on application. Address H. W. PETRIE, adjoining Union station, Toronto.

## ANNOUNCEMENT.



It is with a considerable degree of satisfaction that I can now announce to my extensive circle of patrons and the public generally that a few weeks hence I will have finished one of the most complete warehouses for my line of trade in the Dominion. Realizing to the fullest extent the present and future demands of the trade, I am sparing neither trouble nor expense in fitting up a place of business that will meet all requirements. With a substantial four-story building, having an aggregate floor space of 20,000 square feet, fitted with French plate front on main floor and equally well lighted on every flat, equipped with two of the most approved steam elevators, for passengers and freight, the latter having a lifting capacity of 12,000 pounds, heated by steam throughout and lighted by electricity, with vaults of latest design, while the offices are finished with a degree of elegance, more suggestive perhaps than any department of the solidity of the business I am doing. With all these advantages, I can, with confidence, claim an establishment which will be modern right up to date and well calculated to meet the requirements of many years to come. Nor will my stock fall short of my equipment. I shall make it a fixed rule that no customer entering my warehouse in search of any article whatever in the machinery or supply line, whether it be a complete saw-mill rig or a steam gauge, a fully equipped planing mill, or a belt lace; in fact anything that is made and can be procured will be placed at the disposal of my customers. I can also with satisfaction look back over the events that have led up to the present development. Nearly 15 years ago I commenced business on a limited scale in the busy and prosperous little city of Brantford, and year by year I have seen my field of operation spreading, until I now ship goods to the farthest limits of this broad Dominion, and none but the best facilities, such as are afforded by the leading city of Canada, will meet the demands of my trade. Hence my removal to Toronto, where not only will I have superior advantages for advancing my business interests, but I am placing myself within easy reach of customers at all points; in fact with Toronto's railway facilities I am now in touch with all Canada. I wish particularly to impress on the public my location which has been selected rather with a view to the convenience of my customers than my own special accommodation. I am only 40 yards from the Union station, and have arranged for a broad plank walk from the centre arch-way of the station building up through my premises, giving the public a short cut to Front street and the street railway lines entering there and my customers the benefit of being able to do business in my wareroom up to the very moment their train starts. Also when time is limited, one minute after leaving the train they can be within the walls of my building, which advantage I am sure will be greatly appreciated. I extend to everyone, whether intending customers or others, a cordial invitation to call and see me. I will with pleasure show them over the entire building, with its many floors well filled with the productions of manufacturers from all over Canada and many points in the United States, while in the basement will be seen our work shops, where we repair and refit whatever stands in need of the machinists craft. Come and feel welcome to Canada's most complete machinery depot. Yours very truly,

H. W. PETRIE.

TORONTO AND BRANTFORD.

H. W. PETRIE PROPRIETOR. 141 TO 145 FRONT ST. WEST. TORONTO, ONT.

C. C. CLEVELAND. G. F. CLEVELAND.

**J. L. GOODHUE & CO.,**  
MANUFACTURERS OF  
**Leather Belting**  
AND  
**Lace Leather.**  
DANVILLE - - QUEBEC.

One of the greatest chances in America  
For a Profitable Wholesale Wood-working Industry. One of the best located plants in Tonawanda may be leased, covering seven hundred feet docked water front on the Harbor; with ground five hundred feet in depth; large factory building, two hundred by one hundred and twenty five, with basement; brick boiler and fuel rooms detached, suitable for sash, doors, blinds, boxes, and custom planing combined. Tonawanda although carrying three hundred millions of lumber in stock has yet no large industry such as proposed. Will sell or lease for term of years. Moderate rent, cheap labor, low taxes, lowest insurance.  
**SMITH, FASSETT & CO., Tonawanda, N. Y.**

RAILROAD, BANK & OFFICE  
**DESKS**  
TEES & CO.,  
300 ST. JAMES STREET, MONTREAL.

**STORAGE OF LUMBER.**  
We are prepared to receive any quantity of Lumber for storage. Freight and money will be advanced on same. Also, Warehouse Receipts issued, which can be hypothecated to banks and others. Storage charges easy. For further particulars apply to  
**W. LEAK & CO.**  
Lumber, Coal and Wood.  
DUNDAS STREET, - - TORONTO.

**GOODDAY, BENSON & CO.**  
QUEBEC, P. Q.  
**General Lumber & Timber Merchants.**  
Correspondence is solicited from parties having choice stocks of Hardwood and Pine to offer, either in the log or in sawn lumber.

**JOHN BERTRAM & SONS,**  
CANADA • TOOL • WORKS  
DUNDAS, ONTARIO.  
MANUFACTURERS OF  
**WOOD-WORKING MACHINERY**  
MACHINE TOOLS, ETC.  
Write for Prices and Catalogues

**Packing Cases in Shooks.**  
Any Saw mill in Canada able to undertake large orders for Case Boards is requested to communicate with  
**W. & C. PANTIN**  
147 Upper Thames Street,  
LONDON, - - - - - ENG.

**GEO. CORMACK**  
Wholesale and Retail Dealer in  
*All kinds of LUMBER.*  
Lumber Shipped to all parts by Rail or Vessel.  
WHITBY, - - - - - ONTARIO

William Hamilton, Water Works Department, Pumping House,  
Superintendent, Toronto, Jan. 6th, 1891  
ALONZO W. SPOONER, Port Hope.

Dear Sir,—I am pleased to say that after nearly three years constant use, day and night, on our largest engine your COPPERINE has stood its work well. I have not had to renew any of the heavy bearings yet, so I consider that speaks for itself. I am pleased to recommend it to any one in need of metal to stand heavy work.  
I remain, yours truly,  
J. C. FERGUSON, Chief Engineer,  
Toronto Water Works.

**A. T. ANDERSON & CO.,**  
CONTRACTORS FOR  
**ELECTRICAL AND GENERAL MACHINERY.**  
Complete instalations of team and Hydraulic Power, Electric Light and Power Plants, Wiring and Construction for Arc and Incandescent Lighting. Agents for the celebrated "C. & C." Electric Motors.  
75 Adelaide Street East,  
Toronto, Ont., Canada.  
Estimates furnished and every information cheerfully given to intending purchasers.  
N. B.—Only first-class work on which a full guarantee will be given

**THE RATHBUN COMPANY,**  
DESERONTO, - - ONTARIO,  
MANUFACTURERS OF  
**Doors, Sash, Blinds, Stairs**  
AND ALL KINDS OF WOODEN HOUSE FINISHING MATERIALS.  
CEDAR OIL FOR PURGING BOILERS.  
CORRESPONDENCE SOLICITED

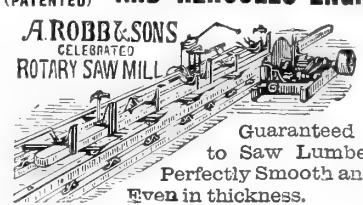
**THE MONARCH BOILER AND HERCULES ENGINE.**  
(PATENTED)  
**A. ROBB & SONS**  
CELEBRATED  
ROTARY SAW MILL  
  
Guaranteed to Saw Lumber Perfectly Smooth and Even in thickness.  
Portable from 6 to 70 horse power. Surpass portable steam power heretofore produced for strength, durability, compactness, and the ease with which they can be moved.  
The 70 horse power can be taken over the roughest roads, or into the forest, and set up as easily and quickly as an ordinary 20 horse power portable engine, and as firm as a brick-set stationary engine. Engines and boilers of every size and description. Rotary Saw Mills, Shingle and Lath machines, Law Grinders, Planers, etc. Mill machinery and supplies of every description. Every boiler insured against explosion by the Boiler Insurance & Inspection Co. of Canada. Write for circulars.  
A. ROBB & SONS, Amherst Foundry and Amherst, N.S. Machine works.  
ESTABLISHED OVER 40 YEARS.

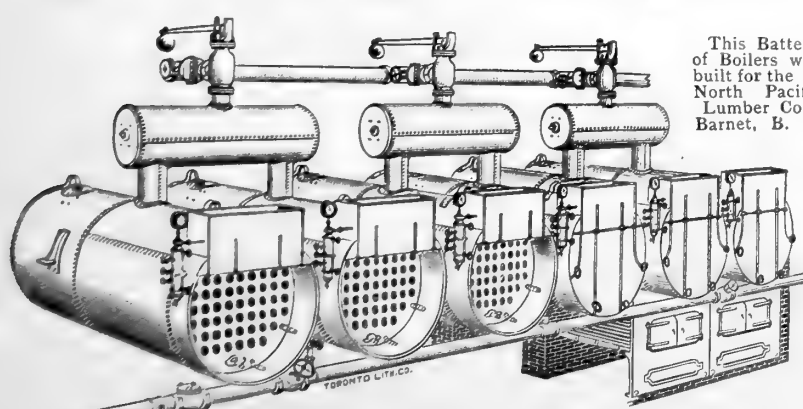
**Boiler and Burner Work**  
  
This Battery of Boilers was built for the North Pacific Lumber Co., Barnet, B. C.  
Send for Estimates  
**Waterous Engine Works Co., Brantford, Canada**

**Menasha Hickory Pulleys**  
We make the only hardwood bent rim spoke arm split pulley, only small split pulley, only wooden hangers in the market. Send for discounts & circulars.  
Menasha Wood Split Pulley Co.  
MENASHA, WISCONSIN.  
**T. SHORTISS,**  
DEALER IN  
**PINE & MINERAL LANDS**  
9 Toronto Street,  
TORONTO, - - - - - ONT.  
CORRESPONDENCE SOLICITED.

**LUMBER TRUCK & WHEELS.**  
\*\*\*\*\*  
**The Montreal** \*  
\* **Car Wheel Co.**  
MANUFACTURERS OF  
**CHARCOAL IRON CHILLED RAILROAD WHEELS**  
\*\*\*\*\*  
Offices: New York Life Insurance Building, Montreal.  
Works: Lachine, Quebec.  
\*\*\*\*\*  
WE make a Specialty of Wheels suitable for the requirements of Passenger and Street Car Service, and can supply them Bored, Finished and Balanced.  
CORRESPONDENCE SOLICITED



TAPER TOOTH.



TELEPHONE 5120.

**Burns**

&

**Thomas**

MANUFACTURERS OF



TORONTO.

All Kinds of

CIRCULAR AND

LONG

**Saws**

LANCE TOOTH.



WORKS AT PARKDALE.

# The Dodge Patent System of ROPE TRANSMISSION OF POWER.

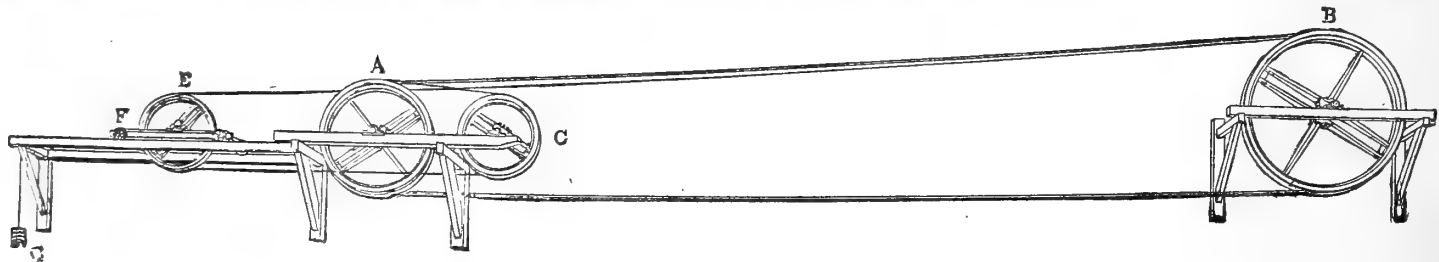

*The above cut represents a simple Drive from one shaft to another, and can be applied in any case, or to any distance, in or out of doors. The ordinary space between centres being limited, to say, 100 feet, after which additional Carriers can be added to any distance. For full information and particulars, apply to*

## \* Dodge Wood Split Pulley Co. \*

City Office, 83 King St., W.

TORONTO.

TELEPHONE 2080.

### THE "LEADER"

The Finest Tempered, Fastest Cutting and Best Saw made on the Continent.



Manufactured of Triple Refined Silver Steel, Rolled specially for us from Superior Ingots.

THE KING OF CROSS-CUT SAWS.

R. H. SMITH COMPANY, LTD., ST. CATHARINES, ONT.

Sole Manufacturers

# THE CANADA LUMBERMAN.

VOLUME XII }  
NUMBER 3 }

TORONTO, ONT., MARCH, 1891.

## BIOGRAPHICAL SKETCHES.

NO. I.

JOHN DONOGH first opened his eyes in the city of Toronto during the eventful year of 1854, consequently he is not an authority, except from reading and hearsay, on the Crimean war, or that free trade period of Canadian history so frequently alluded to by a section of our press, as the only prosperous and progressive epoch since Jacques Cartier stumbled on to our eastern shores. Some ten years of juvenile life spent at Mono Mills, (then in the "bush,") laid a good foundation for his future development of bone and muscle. Subsequent school training received in Toronto fitted him to face the world and carve out a livelihood.

He commenced to carve by delivering "jerked lightning" round the city for the Montreal Telegraph Co., and graduated from the desk of that company to "jerk" slivers out of his fingers when showing lumber to customers for S. R. Briggs, the pioneer lumber merchant of the Queen city.

In '68 there was a slight difference between the office help and furnishings of a lumber firm and the equipment of similar offices in '91. The assistant was a Pooh Bah, and as such waded through the duties now performed by the telephone, the office boy, bookkeeper, city salesman and correspondent. To S. R. Briggs must be given the credit of establishing the wholesale, jobbing or middleman trade of Toronto, his business being almost confined to the disposal of car and vessel lots.

Under such training a man had lumber "greatness thrust upon him," and the subject of our illustration found himself in '76 so "choke" full of logs, lath and lumber, metaphorically speaking, that he embarked in the lumber trade on his own account on the retirement of his employer from active business life.

Joseph Oliver, (a salesman for Briggs) T. S. McCool and John Donogh, composed the new firm, whose shingle suspended over the doorway of 37 Adelaide street, east, read: "Donogh, McCool & Oliver." Some six months spent in their modest offices built up a trade which compelled them to seek more commodious quarters, and they removed to the Imperial Bank buildings on Exchange Lane. In '82 Mr. McCool withdrew from the partnership, leaving the firm to prosper under the name and style of Donogh & Oliver. On the opening of the new Board of Trade buildings, the firm rented a suite of offices on the second floor, overlooking Yonge street, Nos. 213, 214 and 215.

The business of the firm is confined to jobbing alone. They operate no limits, nor do they possess any mills. Purchasing agents cover the ground at all points, who keep them well informed of the quality and quantity of cuts; and agents and salesmen scattered over the inland towns and villages of western Ontario dispose of stocks for the home trade.

The season's output of a great many mills are purchased and sold locally, provincially and to the United States as far east as the Atlantic.

In that class of lumber merchants who do not manufacture and sell wholesale, it was generally conceded that Christie, Kerr & Co., S. C. Kanady & Co., and Donogh & Oliver led the van. The failure of the first two firms, the extra facilities obtained and employed

for purchasing, and a constantly increasing foreign trade, have pulled the firm to the front, and in volume of business they head the list as jobbers.

We selected Mr. Donogh as a subject of our first sketch, from the prominent position he occupies as the ex-chairman of the Lumber Section of the Board of Trade and now the occupant of a seat in the council, where for the first time lumber is strictly represented. His executive ability, backed by such an influential body, must result in redressing some minor evils that interfere provincially with the lumber trade, and the voicing of their resolutions by him, will carry the weight of a member thoroughly determined to fight for any reform, or to oppose any encroachment.

## PERSONAL.

Hon. Mr. Joly de Lotbiniere has been strongly urged to be a candidate for the forthcoming election for the Province of Quebec, but has refused the honor



MR. JOHN DONOGH.

H. Cargill, M. P., one of Bruce county's big lumbermen, was in the city during the month.

G. W. Brisley, a well known and much respected mill man, of Fesserton Ont., dropped dead from heart disease two weeks ago.

Mr. W. Edwards, a well known lumberman and late member for Russell, is again the Reform candidate for that constituency. Mr. Edwards is a capable man and will likely lead his party to victory on the 5th inst.

We were pleased to meet in the office of THE LUMBERMAN, Mr. Wm. Foster, lumber dealer, Owen Sound; W. C. Irvine and Mr. Chas. Ashby, of Pontypool.

Mr. John Stah who had been seriously ill at Quebec, has returned to London, Eng.

Mr. Benjamin W. Arnold, the well-known lumber king of Spanish river, died at his residence in Albany, N. Y., last month. His demise will be learned with deep regret.

Amongst the nominations on the 27th ult. were the names of quite a few prominent lumbermen. In Bruce has two in the field, Cargill, ministerial, and Bruce, in opposition. Ottawa has also two, Robillard, ministerial, Nagle, independent. Ministerial candidates were nominated as follows: Dickenson, Carleton Co.; Desjardins, Hochelaga, Que; Bryson, Pontiac, Que. Opposition nominees are: Schell, Glengarry; Waldie, Halton; Cook, Simcoe; Edwards, Russell; Prefontaine, Chambly, Que.; Meigs, Missisquoi, Que. The conservatives lose two old representatives in Rykert, of Lincoln, and Wright, of Ottawa Co., Que. In the retirement of Alonzo Wright, the Dominion, not the Conservative party alone, suffers a national loss. Irrespective of race or creed, few men in the House of Commons held a higher reputation for honesty and few sacrificed so much time and personal interests. Many patizan causes are advanced as to his reasons for voluntarily giving up his seat, but it can be presumed that a man who knows so much about public questions of the day, knows enough to gauge correctly his own private reasons.

Mr. Jas. Dollar, who was injured on the railway New Year's night, is still confined to his room at Bracebridge, Ont.

Messrs. Fred. Taylor and Charles Marshall, of Orillia, have gone to work on a mill Mr. Wm. Tait is erecting in British Columbia.

T. J. Hammill, Barrie, Ont., a prominent lumbermen, was prospecting in British Columbia last month.

Mr. Wm. Mackay, lumberer, Ottawa, Ont, with his son and the two Misses Mackay, left by the G. T. R. on the 20th on a trip to California.

T. S. Higginson, Crown Timber Agent, in British Columbia, had his leg broken in the railway accident which happened on the Canadian Pacific near Schreiber, a station on the Lake Superior section.

Wm. Stahlschmidt, manager the Canadian Office and School Furniture Co., of Preston, Ont., went west on the 17th ult. to superintend the placing of several car loads of opera chairs, school desks, etc., in Manitoba and British Columbia.

John McLean, the journalistic father of protection, died in Toronto on the 13th. The deceased was born in Glasgow in 1825, emigrated to Canada when a boy, and with his parents settled in Brantford, Ont. Before entering journalism in 1863 on the Hamilton Times, he operated a sawmill at Seneca, Ont. on the Grand river. When the Mail was established in 1870 he was its protectionist editor for eight years, and followed up his theory on the World, contributing largely to that journal's ethics, autonomy in Canadian commerce, education, nationality and patriotism.

Mr. T. S. Higginson, Dominion lands agent at New Westminster, was far less injured in the Canadian Pacific Railway accident near Schreiber than at first reported. His leg is severely bruised not broken.

Mr. Harcourt Smith, of Quebec, who is now in London, Eng., will prolong his visit until the spring.

Mr. Francis Maguire, the well known lumberman, of Ottawa, is assisting the Reform candidate in Renfrew Co., and Mr. A. Miscampbell, M. P. P., of Midland, is opposing his fellow lumberman H. Cook, in Simcoe Co.

Mr. R. S. Wilson, at one time a member of the lumber firm of McCraney, McCool & Wilson, this city, and now with Messrs. W. N. McEachren & Co., was married to Mrs. S. Irving recently. THE LUMBERMAN extends its best wishes for the future happiness of the newly-made twain.

We wind up our fatalities and casualties with a reorganization of the old saw, awaiting the record of the saw for April. "Tree spare the woodman" "Saw spare the sawyer."

### THE CARRYING TRADE.

LAST issue we dealt somewhat at length with the lake trade, its volume and character, and we gave approximate land and water rates of carriage. The contrast was greatly in favor of slack water carriage compared with railroads. While the lakes and rivers have received much attention at the hands of the governments of the United States and Canada, it is questionable whether a proportionate expenditure has been extended to them when contrasted with the vast sums advanced by the Governments to the railways. The volume of trade has increased so rapidly that the governments could hardly pause to nicely adjust proportionate expenditure. It is now, however, clearly shown that both the railways and waterways are required to relieve the congested condition of the carrying trade, and no doubt more attention to the waterways will be given in the future. Much can yet be done by more accurate surveys, increasing the number and efficiency of light-houses, signals and fog whistles, as well as removing interruptions to continuous voyages. The chief and most costly improvements, however, are the removal of all impediments to deep and more extended water navigation. Compared with the advantages to be gained, a moderate expenditure would enable vessels drawing deep water to pass from the ocean to the head of Lake Superior. It was long a problem whether the railroads would not supercede the water ways, and beyond question close-water barge canals cannot compete with the railroads and are almost entirely behind the age. It is now quite clear that for heavy freights, deep slack water far exceeds the railroads.

Human invention is equal to furnishing anything essential to the existence or comfort of the race. Up to the present we were content to adopt uniform railroads. Nearly the entire system in North America has been brought to the standard gauge of 4 feet 8½ inches, and we have pressed for uniform waterway capacity. The requirements of trade have led ingenious engineers to contrive of late a combination of water and railways that will overcome impediments to shipping at much less cost and with much speedier carriage. The invention of the ship railway so constructed as to lift vessels of any tonnage freighted with full cargoes, carry them over the impediment and safely land them in the water on the other side, is but now matured, and has not been yet tested on a large scale suitable to ordinary business purposes. There is no doubt, however, that this can be accomplished with perfect ease and safety. There will in the near future be: (1) The railways. (2) The water ways, slack and close water. (3) A combination of both, being part water and part rail. There will therefore shortly be introduced a new factor in the carrying trade that will play a prominent part in this far-reaching question.

Of late few have doubted that the lake trade would be permanent or that its volume would continue to increase. Freight can be carried from St. Louis, by way of Chicago and the lakes, for upwards of a dollar a ton less than by way of the Mississippi, through the Gulf of Mexico and Atlantic Ocean to New York city. This fact will clearly show to those who have given the subject any consideration that if a line be extended West from St. Louis to the Pacific the country north of it from that ocean will be within the carrying influences of the lakes, and the inhabitants will be able to avail themselves of the waterways with their reduced rates, or will be able to obtain rates from the railways affected or moderated by the lake charges. This territory north of such a line includes thousands of miles of inland water communication on the Mississippi and Missouri and their tributaries, besides the enormous trunk railway systems leading from the west across the country to the lakes. This immense country is yet, where inhabited, sparsely populated, but much of it is entirely unsettled. A few years only in the future will pour from 20,000,000 to 30,000,000 additional population on to this territory in Canada and the States within the carrying influences of the lakes. There is no unoccupied position of the globe that is equal to the territory above indicated as a fertile agricultural country. Both animal and vegetable life attain to the healthiest and greatest perfec-

tion. It is well known that in the east on the other hand the manufacturing population is increasing, and as there is unrestricted freedom of trade between all the States of the union it is quite apparent that the west will continue as now to raise agricultural products for the east, while the east will continue as now to manufacture those utensils required in the west. We have then the one set of producers in the west increasing and the other in the east also increasing, separated by long distances and the lakes lying between them. It is therefore manifest that large as the present volume of freight is it only gives indication of its future gigantic proportions.

The question then naturally arises, is it possible to afford such facilities for the transportation of freight, by any or all the known methods, as will lessen the rates in the interest of both producer and consumer? Is it possible to increase the speed of transit and the safety of the carriage at a less cost than present paying rates?

Until some enterprising company takes a new departure, and improves upon the present gauge, the construction of the rolling stock, and the carrying capacity of the car, the railway charges cannot be greatly lessened for rough freights.

No scientific scheme has yet been advanced by which as great speed can be obtained on the water as on the land. The railroads must therefore in the future as in the past continue to carry all the passengers and light and perishable freights, and these afford no inconsiderable part in the gross earnings of the roads. The great Trunk lines have so lately attained to their present importance that time has hardly established their relation to each other or the public at large. In the past the attitude of the great trunk lines to each other may be briefly said to have been ceaseless war. This severe competition has been the safety of the public in the past, but efforts have already been made to put a period to the prevailing strife. We now hear more of combinations than cutting rates. It is stated that J. Gould is now endeavoring to bring some 75,000 miles of railroad under one joint management. This means nearly half of the railways in the United States. The relationship of the trunk lines to each other and to the public may therefore shortly be entirely changed, not in the direction of reduced charges, but where not held in check by water competition, of increased rates for carriage. Of course the government has always the power of interfering, and might at any time establish a court with wide discretion to prevent exactions and discriminations. Such a court would meet immense hostility, and it is questionable whether with our partizan ideas, any government seeking to enforce its decrees could be sustained on a popular vote. The railways are therefore not likely to voluntarily reduce the charges for carriage.

In an improvement of the waterways, or the waterways and railways combined, the safety to the public lies. Many schemes within the last half century have been projected with the view of accomplishing this purpose. All had the same object in view, though they all differed to some extent. The idea common to all was the necessity for affording free passage-way for vessels of large draught from the great lakes to the ocean. Now that the volume of freight has greatly increased some course must at once be adopted to effect this object. The water-ways are open to all. Any one with sufficient capital can put a vessel on the lakes and defy monopoly or combination, and therefore in the application of a generous policy to the lakes and rivers rests the safety of the public and the relief of the producer and consumer.

Let us indicate some of the schemes projected, all of which have received more or less support, and some of them are still under discussion.

Commencing at the south-east end of Lake Michigan, a ship canal, or ship railway, has been proposed to run to the west end of Lake Erie, thence by that lake to Buffalo; there to be transhipped to the Erie canal (perhaps enlarged) or to the railroads and on to New York city. Part of this scheme includes the enlargement of the Welland canal, or the construction of a ship canal or railway, between Lake Erie and Lake

Ontario. The first part of this route is intended to benefit Chicago chiefly.

In reviewing the lake trade generally, without specially consulting the interests of individual ports, the chief objective point is some distance east and south of the straits of Mackinac, where ships after passing down the Ste. Marie's river from Lake Superior on their journey south and east join those from Lake Michigan. From this point we have proposed improvements of the St. Clair Flats and the navigation generally on to Buffalo, then as before to New York or Lake Ontario.

A canal or railway from the Nottawasaga river to the mouth of the Humber. A canal by way of lakes Simcoe and Scugog into Lake Ontario near Whitby. A canal through Lake Simcoe down the Trent river to the Bay of Quinte.

Finally, a barge or ship canal, from Georgian Bay up French river, through Lake Nipissing, across the divide into Trent Lake, on to the Ottawa river and down to Lachine on the St. Lawrence. A brief examination in a future issue of the above projected schemes will enable us to ascertain how relief to the carrying trade can be best effected.—*Canadian Miller*.

### JARRAH WOOD.

The new "Kew Bulletin" contains an interesting section on the properties and uses of the Jarrah wood, a species of eucalyptus, native of Western Australia. The main difficulties in connection with its use in this country are the cost of freight for such heavy timber from Australia and its intense hardness, which makes it difficult for ordinary English carpenters' tools to work it. The tree which produces it grows generally to a height of 100 feet, and sometimes 150 feet. It is found only in Western Australia, extending over the greater portion of the country from the Moore river to King George's sound, forming mainly the forests of these tracts. According to Baron Muelder, when selected from hilly localities, cut while the sap is least active, and subsequently carefully dried, it proves impervious to the boring of insects. Vessels constructed solely of it have after 25 years' constant service, remained perfectly sound, although not coppered. It has been tried at three places in the Suez canal, and, after having been down seven years, the trial samples were taken up in order that a report on their condition might be sent to Paris. From certain correspondence between Kew and some London vestries, it appears that jarrah has lately been used by the Chelsea vestry for paving the King's road, and by the Lambeth vest in the Westminster bridge road.—*Engineering*, London.

### A LEVEL-HEADED BOY.

A BOY about fifteen years of age applied to a factory on Atwater street for the job of running a small engine in the place of a boy who had quit.

"Have you run an engine?" was asked.

"Yes, sir."

"You understand how steam works, do you?"

"I do."

"You know that water makes steam?"

"Of course."

"How is water got into a boiler?"

"By an injector."

"Suppose you have got too much water?"

"Then I can't get steam enough until I draw it down."

"Correct. Suppose you haven't enough?"

"Then look out for an explosion."

"Correct again. Suppose you found the water almost gone, and couldn't start the injector—what would you do?"

"Come up stairs and notify you to get your insurance policies out of the safe and make a sneak before she busted!"

"You seem to be all right young man, you can come on in the morning."—*Detroit Free Press*.

A fire under a boiler should not be hurried too much but should be left to gain its full strength slowly. This is done easiest by putting in only a small quantity of fuel at a time.



THE NEWS.

ONTARIO.

—Albert Bird is starting a sash factory at Stirling.  
 —Lefroy will shortly have two saw mills running.  
 —Amos Vaughan, lumber, Port Arthur, has failed.  
 —At Warminster Mr. D. Baker has erected a mill.  
 —Londesborough station yard is blocked with saw logs.  
 —E. M. Fralick, planing mill owner, of Napanee, has assigned.  
 —J. A. Cook's new shingle mill, at Sundridge, has commenced cutting.  
 —The cedar mill, Deseronto, commenced running about the first of the month.  
 —Large shipments of tanbark and cedar posts are being made at Owen Sound.  
 —The Muskoka Mill and Lumber Company's cut of timber this season will be 6,000,000 feet.  
 —Thirty men and ten span of horses are drawing the season's cut to Dollar's mill, Brunal.  
 —Mr. Houston intends putting in a new saw mill on his lot west of Lavender, in the near future.  
 —The old Wilson grist mill property in Dundas has been purchased by a Mr. Fletcher, of Alliston.  
 —E. C. Lewis, of Elford, has been shipping large quantities of lumber to Detroit during the month.  
 —Thos. Griffith, Manitoulin, has skidded up to date 6,000 logs and 12,000 pieces cedar for paving and ties.  
 —Mr. Chew, of Midland, has taken the contract this season again to saw the cut in the Severn Bridge mill.  
 —Mr. Shorburd's saw mill, Hillsdale, is sawing a large quantity of lumber for the Toronto breakwater.  
 —Rees & Lozar, Woodslee, commenced running their stave mill in January, with a yard full of timber for bolts.  
 —Thos. Bailey's new saw mill, at Malden, has a capacity of 7,000 feet per day, not 70,000 as an exchange has it.  
 —Along the river banks at Coldwater a larger quantity of logs have been "dumped" than in any previous year.  
 —John Burton, Sr., of Rugby, recently purchased the village saw mill, put it in thorough repair and has commenced cutting.  
 —T. Taylor, East Wawanosh, has the frame of his new saw mill erected, and intends getting in the machinery as soon as possible.  
 —A train of teams drawing 140 barrels of pork left Ottawa for the shanties of W. C. Edwards & Co., at the Desert, on the 16th.  
 —Wood Bros., of Tamworth, are fitting up their mill, putting in a new shingle machine and getting out large quantities of cedar.  
 —Walter James, of Cottam, is shipping large quantities of lumber and clearing off the stock he had on hand previous to selling his mill.  
 —The yards of Wingham's three saw mills are so crowded with logs that plank roads are laid upon the lower tiers to allow teams to unload.  
 —The burning of McLaren's mill at Ottawa throws seventy-five men out of employment, and the employees lose \$50,000 worth of tools.  
 —Duff & Stuart, of Bluevale, have sawn this year over 150,000 feet of custom work. From 60 to 70 teams are delivering logs to their mill yard.  
 —The particulars of last October's sale of crown lands west of Port Arthur are promised by the Ontario Government before the present session is over.  
 —Blythe is reaping considerable benefit from the monthly payment for logs delivered at Gray, Young, & Sparling's mill. The average is \$3,000.  
 —Around Dundalk this season immense quantities of cedar are being cut for contractors. Every variety of saleable timber is being hauled to the R. R. depot.  
 —Paul Bissonette, merchant, of South Casselman, has embarked into the lumber trade and is shipping large quantities of cordwood, etc., from Bearbrook.  
 —The big lumber deal in which the Rathbun Company was to buy out the Gilmour concern has fallen through, and the Rathbun's lose their deposit of \$10,000.  
 —James Bailey, agent for Thos. Caldwell, and James Hough, bush-ranger for Thistle, Carswell & Mackay, were engaged in travelling Caldwell's limit, near Pembroke, for the purpose of placing a value on it. If they can come to terms, Thistle, Carswell & Mackay intend to buy it.

—The Collinsby Rafting and Towing Company are building a powerful steel steam tug at Kingston, the plates, machinery, etc., for which are being imported from England.  
 —James MacLaren & Co., of Ottawa, have asked the fire and light committee of the city council to investigate the cause of their recent fire. Mr. John Rochester also courts investigation.  
 —Messrs. Perry, Reid & Phillips, of Fergus, are cutting large quantities of ties, poles, timber, logs and cordwood along the Grand river in the township of Garafraxa, W., and Luther, Wellington Co.  
 —Pierce & Spearing, Foxmead, who are taking out tamarac ship frames, moulded and bevelled for the State of Maine, met with considerable loss through their foreman's wrong measurements in mouldings.  
 —Mr. Gillies, lumber merchant, left a pocket book, containing \$1,000, in the bed he occupied at Foy's hotel, Eganville, one night recently. It was found by an honest servant girl and returned to him.  
 —Mr. David Porter, of Porter, Reed & Canaan, Owen Sound, has received the contract from the government for building a wharf at Beaverton, to be 1,075 feet long and 20 feet wide, with a pier at the end 30x60 feet.  
 —Pontypool visitors report that the pine and cedar in that locality will soon be a thing of the past. Chas. Ashby has cut logs enough to run his 15,000 ft. per day mill during the cutting season, commencing about April 1st.  
 —R. H. Smith & Co., who have the contract for logging for the Ontario Lumber Co. at Commanda Creek, expect to finish by April 1st. Up to date the quantity logged is nearly 5,000,000 feet. The quantity contracted for is 6,000,000 feet.  
 —Mr. W. J. Reid, of the Reidville mill, near Ayr, has purchased about 300,000 feet of timber, principally pine, a small portion being red and white oak. Within the past two weeks nearly forty loads of logs per day were being drawn to the mill.  
 —Graham, Horne & Co. are asking a bonus of \$800 from the municipality of Neebing, Algoma, for the removal of their saw mill from Vermillion Bay. Their limits are exhausted necessitating the removal of their mill to a stream in some other part of the district.  
 —On the evening of the 14th ult., Geo. Thompson, in the employ of McLachlin Bros., Arnprior, while returning from the roll-way to the shanty at Basin Depot, Nipissing District, was chased by five wolves. He ran for over a mile before overtaking some teamsters and reached them in an exhausted condition.  
 —Murillo in the township of Oliver, Algoma, offers a bonus of \$300 for a custom mill in that municipality, the engine of which must be not less than 16-horse power, to cut custom lumber at \$4 per M; to sell sawn lumber at \$8 per M. and upwards, and to be capable of cutting logs 30 feet in length.  
 —The Longford Lumber Company has made a new departure this winter in shipping a very large quantity of lumber. During January the shipments aggregated about two million dollars' worth, and so far this month nearly a million and a half dollars' worth has been sold and shipped.  
 —Work has been stopped on Smith's large saw mill at Callender, and probably will not be resumed until opening of spring. The walls are up to the height of the first storey. Booth's mill, that used to be working more or less all the year round, is entirely shut down this winter. Not more than three or four men altogether are round the place.  
 —A demand of assignment has been made upon McGinnis Bros., manufacturers of cheese boxes and similar goods, at Parkhill, Ont. The liabilities will approximate \$100,000. The principal bank creditors are the People's Bank, Montreal, and the Union Bank Branch, Montreal. The failure has been caused by Messrs. Wilson & McGinnis, of Athelstan Que.  
 —Barnet & Mackay, of Ottawa, have purchased from the Banque Nationale the 200 square mile Latour limit on the Kippawa for \$15,000, less a commission, it is said, of \$7,500 to McCormack, the bank's broker, and \$2,500 to Latour, P. A. Cotton made the examination on behalf of the purchasers. Six years ago the sum of \$275,000 was declined for the same limits. The purchasers will probably start a saw mill at Pembroke.  
 —Mr. John Rochester, of Ottawa, says in regard to the recent burning of his mill that he believes it was set on fire by scrap iron and tool stealers who prowl around all night at their nefarious business and dispose of their purloining next day at shady junk shops. He attributes the burning of McLaren's mill to the same cause, and expects to see other mills set on fire unless closely guarded by watchmen.

—Cache Bay is one of the many places along the Canadian Pacific railway that have sprung into existence within the last couple of years. The mills belonging to the lumber firm of Davidson & Hay, of Toronto, are located at the mouth of the Veuve River, three miles west of Sturgeon Falls. They are lumbering extensively on the Veuve River in winter, some five camps being at work. In addition to this there is considerable activity in the pulp wood business.  
 —Alex. McCool, who is head filer for the Imperial Lumber Co., Warren, has invented a new method of filing with the Automatic Saw Sharpener, which renders it impossible for teeth to break out of a circular saw in sawing frozen timber. It takes less power to drive the saw than the old way of filing and will stand to cut on ten and twelve inch feed in frosty weather without any trouble. Mr. McCool has been working on this invention for some time and has been successful in his undertaking.  
 —All the framework of Booth's new mill, fronting the Claudiere falls, is now up, and the rest of the structure will be completed as quickly as possible, so as to be ready for operations in the spring. When finished it will be one of the most striking in appearance and complete in equipment in Canada, most imposing as viewed from the centre of the interprovincial bridge which spans the foot of the Falls, and will have a cutting capacity much larger than any other mill in Ottawa.  
 —In the Chancery Division at Toronto, before Mr. Justice Ferguson, Messrs. Shepley, Q.C., and H. T. Beck, for the several defendants, appealed from the ruling of the Master at Ottawa in the case of Ratte vs. Booth, as to the sufficiency of particulars furnished by the plaintiff of the damages claimed by him, upon a reference to the Master to assess damages for injuries to the plaintiff's property on the river Ottawa by reason of the defendants throwing sawdust into the river. Mr. Langton, Q. C., for the plaintiff, contra. The appeal was dismissed with costs, the learned judge holding that particulars of damages were unnecessary.  
 —Thos. Perry, of Bracebridge, is getting out about the usual stock for his mill, but intends manufacturing principally shingles this season, the stock to be handled by Mr. Dollar. Leishman & Sons are also getting out a stock of logs on Black Creek, Stephenson township. Sylvester Brown is stocking his mill as usual, principally from the south branch of the Muskoka river. Mr. J. D. Shier is also getting out about his usual stock. The Myres & Laquire Co. have three twin mills at Tretheway's Falls well ahead, and expect to be cutting shingles early in March. A large portable shingle mill has been purchased by W. B. Gate, to be set up in Macauley township.  
 —Warren, a short distance west of North Bay, on the C.P. R., is fast rising into some importance from the influx of settlers and its exports of lumber. There are no highways graded and crowned except the railroad, yet a phenomenal growth from a wilderness to a settlement in a few years has taken place. The Veuve river drains the country and from the basin the supplies of timber at present is cut. The Imperial Lumber Co. own seventy-five square miles of forest and are operating it this season with five camps and two hundred men. The daily capacity of the saw mill is 100,000 feet, employing, in spite of the latest mechanical contrivances for minimizing manual labor, fifty hands. By means of three switches in the yard and a steam tram line into the bush, logs are hauled almost from the stump to the jack loader.  
 —During 1890 permits were obtained from the City Commissioner, of Toronto, to erect to the value of \$2,364,750. Of the total, \$900,000 was for dwellings, \$313,000 for stores, \$560,000 for office buildings, \$220,000 for alterations, \$104,000 for churches and \$93,000 for warehouses and factories. These figures only apply to that portion of the city where permits are necessary. The total value of the permits during the last five years was:

1886.....	\$1,250,000
1887.....	1,145,000
1888.....	2,085,000
1889.....	2,350,000
1890.....	2,364,000

The above does not include the estimated cost of the new Court House and City Hall and Parliament buildings.  
 —The lumber shipments from Ottawa to the United States for January, as shown by returns prepared in Consul-General Lay's office, amount to \$74,611.69. Of this \$3,741.98 was in bond for export to South America, leaving the amount actually disposed of in the States at \$70,869.71. These figures do not include the returns from Carleton Place, which are not yet in. Last year the returns, including Carleton Place, which was not then established, amounted to \$88,645.52, of which \$69,029.18 was actually used in the States. There is an apparent decrease this January of about \$14,000, but it is expected when the returns from Carleton Place are in that the shipments will be fully equal to those of January, 1890.

—A new pulp mill is in course of erection at Sturgeon Falls.

—Reports from Casselman state that lumbering operations are being pushed vigorously.

—Senator Peter McLaren has invested in over 100,000 acres of timber in the State of Virginia.

—Messrs. Croil & McCulloch, of Wales, are getting out a lot of logs and ties at West Moose Creek.

—Messrs. Salmon & Watson, of 299 College street, Toronto, wholesale and retail lumber dealers, have dissolved.

—The Victoria Harbor Lumber Co. will saw their usual quantity of logs, but manufactured fewer this winter than in past years.

—Of the 7,000,000 feet of lumber exported from Ottawa, one-third went to the United States; one-third to South America, and one-third to England.

—Many teamsters in the Ottawa Valley lumber camps have returned mourning the loss of valuable horses, injured, drowned, or dead from an epidemic that prevailed.

—The Georgian Bay Lumber Co. have worked their limits very lightly the present winter, logging only some 20,000,000 feet, owing to an extra large cut during the winter of 1890.

—Mr. James McGregor, of Ottawa, left recently for McLaren's limits, on the Gatineau, with a gang of men to explore the timber belt and report thereon to an English syndicate.

—The Ottawa saw dust case was up for hearing during the month. The master in Chambers at Osgoode Hall heard arguments as to the amount of damage committed. Mr. Ratte, plaintiff, was instructed to file specific damages.

—Shantymen have had a tough time to pull through the winter unemployed, owing to some of the largest mills in the Ottawa Valley not operating their limits. The closing down for the coming season of the same mills will throw from 150 to 200 trained mill hands out of work.

—Gillies Bros., Braeside, have closed up the lumber camp on Otter Lake, on the Kippewa, owing to there being no more timber to cut. Old lumbermen are of the impression that the drive will be a late one this season, judging from the appearance of the creeks and heavy snowfall.

—Mr. Tobin, of Kingston, has finished his tie contract for the Ogdensburg market. He has also 3,000 telegraph poles ready for shipment between Sharbot lake and Russell's siding, but cannot get them across the line before March 1st. They are then subject to a duty of 20 per cent., and he claims he will lose \$600 on the consignment.

—Fort William has voted a bonus of \$8,000 to Graham, Horne & Co., for the removal of their lumbering plant from Vermillion Bay to East Fort William. It is expected that the new industry will employ 70 men and handle 10,000,000 feet of dressed lumber per annum. It is all marketed in the Canadian north-west. In another column the bonus is stated to be \$800. This amount should be \$8,000.

—Mr. Perkins, a member of a manufacturing firm in Michigan, has a patent on shingle mill machinery which is said to be of superior value and will enable him to outdo competition in this line of manufacture. He proposes, if the town of Peterboro' will assist him, to build on the Wm. Hamilton Manufacturing Co's. property. He will put up buildings and put in machinery at an estimated cost of about \$15,000, and employ at the start 30 or 40 hands.

—All through Algoma, and down the district of Parry Sound and Muskoka, large quantities of spruce is being shipped to the other side to be manufactured into paper. It is estimated that 10,000 cords will be got out at Thessalon, while at Cache Bay 50,000 cords will be shipped. This new industry will temporarily make up for the loss in the telegraph pole and tie trade caused by the McKinley tariff. The price now paid is \$2.40 to \$3.00 per cord. Competition raised the price to \$5.60 for a short time at Burk's Falls.

—Senator Clemow, Mr. Hiram Robinson, Hon. E. H. Bronson, Messrs. W. G. Hurdman, E. B. Pattee, W. Maclean and other prominent citizens of Ottawa, discussed the question of establishing a factory for the manufacturing of band, circular and other saws in the capital. The meeting, presided over by W. H. Fuller, was well attended. It was decided that as the prospects for a remunerative business were promising, a company should be immediately formed with Mr. Joshua Oldham, the well known saw maker, of New York, as manager.

—The Rainy river forms part of the international boundary line between Manitoba and Minnesota and discharges the waters of Rainy Lake into the Lake of the Woods. For some time past surveyors have been locating the Rainy River railroad, a

line projected to tap the timber and mineral resources of the country around the chain of smaller lakes between the mouth and the head of the river. The advance guard, or pioneers of the expedition, in their exploration report immense forests of pine surrounding Clearwater lake, two arms of which will be touched by the railroad; large tracts of land badly burned in parts of Moss township, and great water stretches, navigable streams, and small lakes, which will allow the transportation of unsawn timber almost anywhere.

#### QUEBEC.

—Thos. Pringle, millwright, Montreal, has admitted D. A. Pringle, under style of Thos. Pringle & Son.

—Mr. J. Girard, of Lacolle, is selling out preparatory to establishing himself in the lumber manufacturing business in Montreal.

—The creditors of the Buckingham Pulp Company met in Montreal. This industry was started a couple of years ago with a capital of \$70,000.

—Mr. George Willard, Magog, has purchased the machinery of the Georgeville saw mill, and is placing it in the old Varin mill near the station.

—J. B. Fregean, of Standard, whose veneer mill was burned last month, has leased the Sarles' veneer mill at Newport, to cut logs until his old mill is rebuilt.

—McLachie & Gibson, who run a saw mill on the Gatineau road, about thirty-five miles from Ottawa, have the contract for supplying immense quantities timber to the Gatineau Valley R.R. New machinery is being placed in the mill to meet the expected requirements of the trade when the railway reaches the section.

—The winter of 1890 was an open one around Sutton, preventing the log cut from being marketable. Good snow roads this season have allowed immense quantities of hemlock, basswood and spruce, to be "dumped" along the river bank between Sutton and Richford, awaiting the spring freshet. The bulk of the timber will go into the neighboring States.

—Among the creditors of Messrs. Wilson, McGinnis & Co., cheese box makers, of Athelstan, who failed recently are: The Banque du Peuple, \$12,000; Eastern Townships Bank, \$5,400; Ward, Carter & Co., \$1,000; Bank of Toronto, \$800; Union Bank, \$1,260; S. Greenshields, Son & Co., \$1,500; Montreal Peoples' Bank, \$1,300; Malone, N. Y., Dr. Cameron, \$800, Huntingdon; Ranson, Forbes & Co., \$800; McLachlin Bros. & Co., \$800, Montreal; John Call, \$600, Front River; John Cairns, \$900, Athelstan; Gault Bros, \$600, Montreal; Wm. Paterson, \$1,000, Port Scott; Andrew Gilmour, \$1,200, Huntingdon; James Johnson, \$800, Parkhill; small amounts to farmers, \$30,000.

—On February 14th, Judge Andrews at Quebec, entered judgment in the important cases of La Banque du Peuple vs. Bryant, Powis & Bryant, Limited; the Union Bank against the same company, and the Quebec bank against the same company. These cases involve about \$100,000 and arose out of notes and bills of exchange purporting to be signed by C.G. Davies as attorney for Bryant, Powis & Bryant, Ltd., under a power of attorney. The questions were of great importance to the business community and turned largely on the effect of the power of attorney. The cases of the Union bank and La Banque du Peuple have been dismissed, but that of the Quebec bank has been maintained.

#### NEW BRUNSWICK AND NOVA SCOTIA.

—J. H. Tiers, lumber, Hampton, N. B., has assigned.

—Dungarvon and Renous lumber camps are still at work.

—Jas. McKinlay, spool manufacturer, Musquodoboit Harbor, N. S., has assigned.

—Stevens & Robinson, lumber, etc., Salmon River, N. S., have dissolved.

—The William Law Shipping Co., of Yarmouth, N. S., are asking for incorporation.

—A few camps from the head of the river at Doaktown, N. B., have been abandoned, owing to deep snow.

—Ship building is being carried on extensively in parts of Nova Scotia this winter. In one district alone along the Cumberland shore there are 13 large vessels in course of construction. In other districts, in Liverpool, Lunenburg and Shelburne counties, there are a number of vessels of all sizes on the stocks.

—Mr. Reuben Harlow, a merchant and lumberman of Liverpool, Queen's Co., has purchased the stock and good-will of the business of Mr. W. H. Guild, at Shubenacadia, N. S. Mr. Harlow will conduct a general merchandise business at the store, and will also carry on a lumber business at Shubenacadie.

—Messrs Frank Todd of St. Stephen, A. E. Randolph and Allan Ritchie, forming the New Brunswick lumber commission, with their secretary, met at Fredrickton last week for the purpose of determining on a course of action with reference to the inquiry they have been appointed to make into the question of stumpage. It was decided to take the evidence of lumbermen at meetings to be held the next few months in different parts of the province, and, from these, with what information they may be able to obtain by means of circulars and otherwise, to frame their report, which will, in all probability, be submitted to the legislature, during the session of 1892.

—The old firm of B. Young & Son manufactured in 1890 eight million feet of long and five million feet of short lumber. This was their smallest cut for several years. The new firm of Young Bros. & Co will put out this season 5½ million feet at Newville, N. S., and 3½ million at River Hebert, where they will manufacture 1½ million shingles this winter. They have 35 horses and 70 men at Newville, and 24 horses and 48 men at River Hebert, making a total at both branches of nine million feet logs, with 118 men and 58 horses employed. They intend to manufacture from six to seven millions of this cut into deals for English market; the balance will be manufactured for the American market. They will also manufacture about seven million of laths the coming season for the American markets. They manufacture about 80 M long lumber and 75 M short lumber per day at both mills, and when mills are working employ 75 men directly, and about as many more indirectly in carrying deals, loading vessels, etc.

#### MANITOBA AND NORTH-WEST.

—The Lake Winnipeg Transportation Lumber and Trading Co. of Selkirk, have applied for an order to wind up their affairs.

—The C. P. R. have arranged with Ross, Hall & Brown, of Rat Portage, and the Western Lumber Co. for their entire cut of slabs for the coming season.

—Messrs. Moore & McDowall, Prince Albert, have 2,000,000 feet of first class lumber ready to ship south upon the completion of the spur track to their yards.

—The cost price of lumber f.o.b. at Union Point is \$12.00 per M, divided as follows: cutting and hauling, \$4.50, government duty \$2.50, and sawing \$5.00.

—Timber contractors of Winnipeg find it difficult to secure enough men to complete their gangs in the woods, on account of so many laborers having gone to work on the Pacific division of the Great Northern Railway.

#### AMERICAN.

—Tonawanda lumbermen claim they have handled 800,000,000 feet of lumber last year.

—Production of white pine lumber for 1890 is put at close to 8,650,000,000 feet.

—The Illinois and Central Railroad handled 20,579 cars of lumber in Chicago last year.

—The lumber shipments from the Minneapolis market during 1890, as given by ten railroads, amounted to 300,495,000 feet.

—Sibley & Bearinger are putting in 20,000,000 feet of logs in Canada, which will be towed to Tawas and Saginaw River to be manufactured.

—The irrepressible statistician now claims for Louisiana a wealth of forest timber aggregating 50,000,000,000 feet in round numbers.

—It is estimated that Cheboygan lumbermen own 3,000,000,000 feet of pine on Rainy River, which is probably an overestimate. An effort is being made to build a railroad to this timber.

—The report is abroad that British capital is behind a scheme to consolidate the principal manufactories of spools, bobbins and shuttles, under the name of the American, Bobbin, Spool and Shuttle Co., with a capital of \$5,000,000. Portland, Me., is to be head-quarters and the combine is to embrace about 85 per cent. of the manufacturers in the lines named. The factories are nearly all in Maine and other New England states.

—It was the intention of several Michigan firms to supplement their state cut by drawing on Canada for an unusual supply of logs. The Saginaw Salt & Lumber Co. made preparations to increase logging on the Spanish River. Hewery & Sons, who operate on Little Creek, were to exceed their usual make of logs by 10,000,000 feet. The Emery Lumber Co., working in the French River district, C. K. Eddy & Sons, Sibly and Barenger, and several other firms purposed increasing their log supply in the fall. As their reports of progress or delay naturally drift towards their head office, THE LUMBERMAN has been unable to ascertain up to date how far the season's operations have advanced.

**BRITISH COLUMBIA LUMBER MATTERS.**

NEW WESTMINSTER, B. C., Feb. 20, 1891.

Since my last the weather has continued fine. We experienced a colder snap during the last week, with a little snow. This in no way interfered with the mills, as no ice formed. In some cases logging camps have been at work all winter. A very lively season is expected, locally at least. The export trade has fallen off simply from the great scarcity of vessels. It is to be hoped this will not continue.

Several new saw mills are talked of, viz.: at Liverpool, opposite McLaren-Ross mill; at Hall's Prairie; one by Clarence Debeck, a late partner in the Brunette Saw Mill Co., on the north-west coast of the mainland, with a capacity of 100 M per day; one by N. Slight & Co., late of Michigan, at Steveston, near mouth of Frazer River; one by C. L. Street & Co., at Chilliwack, now almost ready and making a specialty of box lumber.

Messrs. John Whyte & Hammill are advertising for limits and intend building, but I cannot say where.

I am indebted to the Royal City Planing Mills Co. for a photograph of the three sticks of timber shipped from their Hastings mill to the Harbor Commissioners of Montreal. They are 36x36x60 feet each, containing 6,480 feet B.M. each. The total weight was 60,000 lbs. Their mill here is now executing an order for timbers 34x36 to 40x40 square 40 to 50 feet long.

There are 41-saw mills now built or under construction in this province, 45 timber leases comprising 225,526 acres. The annual rental is \$15,614, and the revenue from timber royalty for 1890 was \$29,700.

During the month our city has been lit by electric light and is much improved thereby.

The Victoria Lumber and Manufacturing Co., whose mill is at Chemainus, will begin cutting early in April, with a capacity of 200 M per day. The Brunette saw mill starts again this week, after completing some improvements and alterations. The McLaren-Ross mill is soon expected to open up full blast. Mr. Smith from the east is building a mill at Vernon. A fire in Muirhead & Mann's sash and door factory, in Victoria, caused \$1,000 damage. They were very fortunate in confining the fire to such a small amount.

The cut of the Moodyville mill for the year was: Lumber, 18,594,738 feet; 18,598 bundles laths; 81,108 feet pickets.

The certificate of incorporation is published of the Michigan Lumber Company with a capital of \$1,000,000 divided into 10,000 shares of \$100 each, with headquarters at Vancouver. The incorporators are Henry R. Morse, Henry R. Morse, jr., both of Vancouver, and Angus C. Boggs, of Alpena, State of Michigan.

The machinery has been purchased for a new saw and planing mill at Mission.

The tonnage of the vessels hailing from New Westminster engaged in the milling trade is 826.

The Idaho, of New Westminster, is making preparations to tow logs from Crawford Bay to the Davies-Sayward mill, her captain expecting her to make daily trips with a 50,000 feet tow.

An instance of the magnificent timber which can be furnished in British Columbia, 50 of the sticks in the swing bridge at Mission Station are from 78 to 97 feet in length, and were cut by the Hastings saw mill, Vancouver, and many of the piles used were 85 feet in length. The river is 60 feet deep during summer; now it is about 43 feet with a tide of about six feet.

The Hastings saw mill produced during 1890, 30,000,000 superficial feet of lumber, valued at \$1,750,000. Of the foregoing, 13,059,000 feet were rough lumber, 955,000 dressed, 107,000 pickets, and 20,180 laths. Shipped to foreign markets, 1,699,000 feet rough; 544,000 dressed, 107,000 pickets, and 17,020 laths. Rail shipments were 407,000 feet rough, 23,000 feet dressed. The local market consumed 1,953,000 feet rough, 388,000 feet dressed, and 3,180 bundles shingles.

The Mechanics saw mill, of New Westminster, has been running all winter. It is reported that additions will be made to it in the spring. Two large booms of logs arrived at the mill during the month.

Amongst the shipments of the Royal City Planing

mills were the last two sets of long timber for Dayton, Ohio, a carload of dressed lumber for Lethbridge, N. W.T., four carloads of assorted lumber and ties for the east and carload for Sherbrooke, Que. Their new steamer is expected to be finished this month. A rearrangement of the lumber piles in their large yard has been made.

W. P. Sayward, of Victoria, started a lumber camp in the Otter district.

The length of the large band saw in Jas. B. McLaren's mill is 46 feet.

The Fraser River Lumber Company, Ltd., has been incorporated with head office at New Westminster. The directors are: Messrs. M. G. Terhue, Grier Starrett and Joseph Saint.

The Brunette saw mill, at Sapperton, has been thoroughly overhauled and repaired, the large boiler purged of sediment and the foundations re-bricked. In addition to their logging camp at Mud Bay, started in January, they are operating with another at Clover Valley, the cut of which will be driven down the Nicomel River to Mud Bay and towed from there to Sapperton.

After writing several times and waiting two months I can only give you the cut of the mills for 1890 who have responded to my request, several have not sent returns:

CUT OF 1890.

Victoria Lumber Manufacturing Co.	4,000,000 feet
A. McKinnon, Duncan's	500,000 "
Moodyville Saw Mill Co.	18,620,000 "
Royal City Planing Mills Co.	35,000,000 "
Hastings Saw Mill Co.	30,000,000 "
J. B. Tiffin	3,800,000 "
Brunette Saw Mill Co.	9,000,000 "
Nanaimo Saw Mills	6,000,000 "

In the foregoing the Brunette S. M. Co. cut 3,000,000 with their old mill and 6,000,000 with the new one. They lost considerable time in building and moving into the new mill. The cut of Hastings is also small, as the mill has been thoroughly repaired and was prevented cutting while the same were going on.

Moodyville Saw Mill Co. laths	22,509 bundles
Brunette Saw Mill Co., shingles	3,000,000
G. F. Slater,	12,000,000.

H. G. R.

**NOVA SCOTIA MATTERS.**

BRIDGEWATER, Feb. 14th, 1891

We are having a steady winter in this district, and in the forest at the heads of the rivers have had the best hauling for a number of years. Loggers on the Victaux, Port Medway, Musha Muish, Liverpool and St. Margarets Bay, Gold River, and in fact all around the Lahave River, are putting in timber very freely from lands having long roads which have been impassable during the last three winters without snow.

Several of our smaller operators, having been tempted by the fine hauling, have started work on the Lahave, counting somewhat on the justice of their claim to work like their neighbors, and being about at the point of rebellion against any authority which attempts to stop them.

Petitions are now being, for the third time, circulated through the Lahave valley, asking that the river be exempted, the same as the neighboring rivers in Queen's County, and the people are signing them *en masse*.

Business in Bridgewater and vicinity is duller than known for many years, and the traders were afraid to stock up enough to supply provisions needed for the winter. The banks are endeavoring to keep their customers afloat, and so far very few failures have occurred.

The dull season among the fishermen on the banks last year has checked the building of so many new vessels, and labor has more trouble to find work near at home, so that many of our young men have gone to other districts for work.

The argument of the sawdust destroying the fisheries is again being refuted by the Salmon themselves schooling into the Port Medway river earlier than usual, in the face of three gang mills running night and day dropping sawdust into the river all last season. However, as they have faced the same kind of sawdust for the last hundred years nothing else was to be expected, and we would most respectfully suggest to Mr. Wilmot, or some of the Fishery Department, that the same

description would suit this river, and we could dispense with our most fastidious breed who are in the habit of turning back when they see our sawdust in ten feet of water, according to the theory of Captain Gordon of "Kannuck Navee"

But joking aside, our people need the lumber business re-established, and demand the same treatment as the rest of the Dominion, and having waited three years for the law to be put in force on other rivers say they must be allowed to work, as the government have no intention of enforcing the law generally, and they cannot prove one dollar's damage done on this river by allowing the sawdust to run as formerly. The question is beyond any politics with our people, and both parties unite in demanding their right.

Most of the members of the House of Commons for Nova Scotia contend for allowing the mills to saw, and the Fishery department will have to either enforce the law against all mills, or drop the prosecution of selected subjects.

We do not pretend to judge of the operation of the practice in the large alluvial rivers of the West, without any tidal changes, but the case has yet to be found where sawdust alone has done any damage to Fishery or navigation on the Atlantic coast of Nova Scotia.

With the present fine winter the Lahave mills could have been stocked with 25 million ft of timber, yielding an increase to county and shipping of \$200,000 or \$300,000, which is all sacrificed to the theoretical ideas of the present managers of the Fishery Department.

FRANK DAVIDSON.

**AN IMPORTANT ITEM.**

IN planning and equipping a wood-working plant there is one very important matter which is often left out of consideration, and this is the providing of the necessary facilities for keeping the different machines in good working order, with the least possible delay and cost. One of the best investments that can be made in establishing a wood-working plant is in providing these facilities, and then having a man in charge who thoroughly understands his business. These facilities do not require a great outlay at the start, and will show a larger percentage of profit than any like sum put into any other part of the equipment. The repairs in and around the plant are an important item, and a proper provision for this is worth considering. You do not need a whole machine shop outfit, but you do need a few small tools, which should be carefully selected, taken care of, and always ready for use when needed. The delays caused by being obliged to depend upon some neighboring machine shop for all the little repairs are costly, to say nothing of damage to machinery resulting from neglect to keep it in proper repair, through a lack of the facilities at hand for doing so. A great deal of valuable and costly machinery is thus ruined every year, and too often the blame is laid to the manufacturer, and he is accused of using poor material or employing poor workmen.

**TIMBER SUPPLY OF THE NORTH-WEST.**

The question of the future lumber and timber supply of northwest territories is receiving the attention of the Dominion government just now, and it is probable that more stringent regulations will be adopted by parliament next session to insure the forests against reckless depletion and destruction. The logs of the Prince Albert district are cut on streams tributary to the Saskatchewan on the north side, principally on the Little Red, Sturgeon and Shell rivers. There is a vast timber belt immediately to the north of Prince Albert. Spruce is the principal variety of lumber cut. The logs run from one to three ft. in diameter, but logs have been cut which went over three feet. Some tamarac is also cut at the mills. It is harder than the spruce and is used for flooring, sills, etc. It runs from one to two feet in diameter. Birch is hardwood lumber and is used for finer class of work, inside finishing, cabinet work, etc., and it will make very good furniture. Poplar may be used for work where basswood is used in the east. The northern poplar lumber resembles basswood. This northern spruce is a splendid lumber, being much superior in quality to southern and eastern spruce. It is whiter in color, softer and finer texture, and much more free from knots. In fact it makes an excellent lumber, and quite as good as much of the white pine in the east.





PUBLISHED MONTHLY BY  
ARTHUR G. MORTIMER,

OFFICE:

75 CANADA LIFE ASSURANCE BUILDING,  
TORONTO, ONTARIO.

TERMS OF SUBSCRIPTION:

One Copy one Year, in Advance, - - - - \$1.00  
One Copy six months, in Advance, - - - - \$0.50

Advertising Rates Furnished on Application.

THE CANADA LUMBERMAN is published in the interest of the lumber trade and of allied industries throughout the Dominion being the only representative in Canada of this foremost branch of commerce of this country. It aims at giving full and timely information on all subjects touching these interests, discussing these topics editorially and inviting free discussion by others.

Especially pains are taken to secure the latest and most trustworthy market quotations from various points throughout the world so as to afford to the trade in Canada information upon which it can rely in its operations.

Special correspondents in localities of importance present an accurate report not only of prices and the condition of the market, but also of other matters specially interesting to our readers. But correspondence is not only welcome but is invited from all who have any information to communicate or subjects to discuss relating to the trade or in any way effecting it. Even when we may not be able to agree with the writers we will give them a fair opportunity for free discussion as the best means of eliciting the truth. Any items of interest are particularly requested for even if not of great importance individually they contribute to a fund of information from which general results are obtained.

Advertisers will receive careful attention and liberal treatment. We need not point out that for many the CANADA LUMBERMAN with its special class of readers is not only an exceptionally good medium for securing publicity but is indispensable for those who would bring themselves before the notice of that class. Special attention is directed to "WANTED" and "FOR SALE" advertisements which will be inserted in a conspicuous position at the uniform price of 15 cents per line for each insertion. Announcements of this character will be subject to a discount of 25 per cent, if ordered for three successive issues or longer.

Subscribers will find the small amount they pay for the CANADA LUMBERMAN quite insignificant as compared with its value to them. There is not an individual in the trade or specially interested in it, who should not be on our list thus obtaining the present benefit and aiding and encouraging us to render it even more complete.

TO VISITING LUMBERMEN.

LUMBERMEN visiting Toronto are invited to use the office of the LUMBERMAN as their own. We shall take pleasure in supplying them with every convenience for receiving and answering their correspondence, and hold ourselves at their service in any other way that they may desire.

"CHARLES SMITH, of the saw mill on Main street, has taken as a partner Frank Scratch, son of H. P. Scratch, of the Section."—*Ex.* The junior in the office, he who is likened to the hoofed, horned and tailed gentlemen, says: "Our contemporary need not make so much fuss over the new partner; a scratch is nothing uncommon round a saw mill."

READERS who are fond of statistics will find some interesting figures and excerpts in another column taken from the annual wood circular of James Smith & Co., Liverpool, Eng., dated Jan. 31, 1891. The remarks on wood and timber as condensed are almost confined to the colonies, but the totals of foreign importation are given to allow comparison.

Pattitville mills were to have resumed work a week ago, but it was reported that some of the men found a newly dug grave in the woods not far from the mill. This so startled the inhabitants of that peaceful burg that work for the time being has been suspended.—*Ex.*

THE delightful haziness of this news note puts the reader in a quandary as to what was suspended—the intended occupant of the grave, the work in the mill, or the work of the inhabitants. We presume the writer intended to convey the fact that the mill ceased running. It has been our duty for some years to chronicle the

stopping of mills from lack of logs, want of water power, financial difficulties and other ordinary causes, but this is the first occasion we have ever heard of one stopping from finding a hole in the ground. It is a poor way of advertising a place to leave the impression that the duties of sawyer, engineer, slab carrier and yardsman were performed by one employe, who struck work to speculate on a pile of dirt along side of a post-hole in a bush. Far better adopt the advertising fads of our neighbors to the south of us, as detailed by Dickens in his description of ague smitten Eden, or work on the lines of the late booming given to Yokalahama.

OUR list of casualties for the past month is again unusually long, both in shanties and saw mills. It is not a subject to jest about the loss of a limb or other permanent injuries, but frequently serious accidents occur from rashness and carelessness. If the injunction laid down by the old Scotch mill man, who painted the heraldic emblem of his country on the door of his mill, and interpreted the inscription found there on *nemo me impune lacessit* in his own vernacular, "Dinna monkey wi the buzz saw whan she's rinnin"—if the injunction was carried out strictly, there would be more fingers per capita to the population, and the wooden-limbed industry would languish.

Alex. Crooks, the genial and popular proprietor of the Albion hotel, is one of those good natured bonifaces who carries his full share of adipose tissue under his vest and one of the last men you would think would say nothing but saw wood. On Saturday, however, Alex. met the cordwood editor of the *Star* and said, "I can beech you sawing wood and I haven't cut any for fourteen years until this morning when I butchered enough to last till Tuesday. I tell you straight I'm dead in love with the job, in fact I just pine after it." The cordwood editor replied that he occasionally slaughtered a few sticks himself, but it wasn't on account of any particular hankering for the job. And then the band played.

We willow the *Star* considerable if it will pitch this chestnut amongst the ashes. The alder it gets the the larcher the hawthorne it will become. Was Crooks butchering ma-hog-any? Palm this off somewhere else. Cedar! Some of these are pretty fir fetched, but we will spruce up and do better next time.

OUR regret, expressed last month, at our inability to be present at the annual dinner of the Buffalo Lumber Exchange turned to remorse on reading the various reports of the gathering. If anything remained after digesting the "feast of reason and the flow of soul" to turn our remorse to gall it was not being present to digest the viands. There is food for reflection in contrasting the *menu* of the nabobs in the Buffalo and Tonawanda lumber trade with the average *menu* of the shanty man. Shortly before they gathered around their regal feast, shanty men who were supplying the raw material to indirectly supply next season's dinner, had gathered around their frugal board. If the Mayor of Buffalo had been invited to a shanty banquet, there would be some force in his expressed wish, "to leave the party early" without definitely stating whether the early referred to the evening or the morning hours, and if the speakers had been asked to fill their programs with shanty dinner delicacies, their oratorical efforts would probably not have been so brilliant. Let us contrast the respective bills of fare.

MENU	CHUCK
Blue Point Oysters.	Nianty Atmosphere
Claret	Cold Tea
Olives	Browne
Colery	Bark
Gherkins	Silvern
Consomme au Vermicelle	Consomme au Baked Dough
Broiled Bluefish a la Maitre d'Hotel	Bouiled Pig a la Kettle
Julienne Potatoes	Cardiganed Potatoes
Bouchees a la Reine	Colp Hog Bouiled
Fillet of Beef	Larded Saus
Larded Sauce	Swamp Water
Maderia	Ribs Punched
Cardinal Punch	More Tea
Champagne	Beans
Roasted Quail with Lettuce	Roast Beef with Let us Sing
Rhine Wine Jelly	Aromatic Wet Socks
Ice Cream	Prosen Ice
Tortoni	Chopped Ice
Cakes	Srambled Ice
Coffee	Soap Cakes a la infinitesimal
American Cheese	Pine Cones
Cigars	Pocket Knives
Brie Cheese	Clay Pipes
	Black Strap
	Tobacco Smoke

The forty-nine gentlemen who punished the Genesee lay-out must have enjoyed themselves, but it is questionable if they pushed their heads through their upper storey underwear on Sunday morning with as much gusto as the shanty man hung his up to dry after finishing his week's washing.

A RELIABLE subscriber from New Westminster, B. C., brings us to task over several news notes published in our February issue. Like all journals we have to depend on a percentage of clippings for information. If these are inaccurate we are indirectly responsible for them; if they mislead, we mislead by publishing them. On page 10 of our last number we state that "a mill is in course of erection for Elmer Ward." We cut this clipping from a New Brunswick paper. It seems, despite the C. P. R., that news takes a long time to travel from the Occident to the Orient. The mill was built early last summer. On page 11 we give the capacity of the Royal City mills as 45 M per day. It is double that. Our "devil," who has nothing in his head, got a good chance to work some nothings in on the cost of the Mechanics mill, making it \$35,000,000 in place of \$35,000. R. Morse, jr., operates the Fader mill, and not Morse & Boggs. These inaccuracies are excusable from the fact that we have not time between issues to verify reports. If editors of local papers will not supply trustworthy information which we reproduce we will be more than pleased if our subscribers bring the errors before our notice.

THE *Official Gazette*, of British Columbia, announces that no public land will be sold until the legislation now under consideration becomes statutory. Members of the Legislature and other prominent men have advocated their ideas so strongly that the Government is at present framing laws to completely control all forests, public lands, mines, and waters, to hold them for the benefit of the public and to prevent them from becoming the property of private syndicates or speculators. If British Columbia passes a crown lands act such as is under contemplation, and includes in the act conditions for the proper sale, rental or preservation of her natural products, she will lead the van in Provincial legislation, and prevent the repetition of such egregious blunders as those that retard the commercial progress and have strangled the natural development of Ontario and Quebec. Instance after instance might be cited of the gigantic evil of allowing real estate speculators, not to mention partizan political heelers, to gobble townships at one nibble, which they held, expecting to bleed some private individual or firm who might be induced to purchase. This system of land tenure is most pernicious, and if British Columbia successfully carries any Provincial act which grapples with the evil, the results of the act will be watched carefully by the older provinces.

A CORRESPONDENT of one of our British Columbia exchanges winds up his local lumbering news paragraphs from Stave River with: "Delightful weather. The ring of the merry woodman's axe, and the resonant reverberations of my neighbor's recluse rooster, the rollicking rumpus of the bear, the twitter of the chickadee, and the chatter of the chipmunk, all proclaim that nature is alive and whooping." On the coast they may have an Italian summer, but they have no real Canadian winter. The seasons are the wet and the dry. Away in the east we have seen men wrestling between the wet and the dry seasons, when in the early hours of the morning the sufferer from the "jim-jams" sticks his burning head into a pail of water and gets his stomach outside of half its contents. Our indirect correspondent has evidently a pretty severe attack of the "jams," but spring is approaching in eastern Canada and the Pacific slope will no longer enjoy a monopoly of pastoral ditties and perorations. We have only recently unloaded our waste basket, bursting with all poetical effusions of the "bootiful snow" order, and we cannot brook without comment this inroad on our season of respite, between the month dedicated to odes on "bootiful snow," and that part of our year given up to doggeral on "hail gentle spring."

THE Vermont Shade Roller Company appealed against the rate of duty assessed by the Burlington, Vt., collector of customs on an importation of pine lumber from Canada, entered October 13th, 1890. The collector levied the assessment at the rates prescribed in the act of 1883. The appellants claimed that duty

should be levied at the rates named in the tariff of 1890. The U. S. act of 1890, dated October 1st, provides "that in case any foreign country imposes an export duty on their logs entered for consumption in the States, the sawn lumber from the said country shall be subject to the import duties of the act of 1883. On October 13th the Canadian government removed the duty on pine logs, and as a consequence all lumber imported by the States on and after that date is entitled to the provisions of the act of 1890. The treasury department of Washington have decided, in the case under consideration, where the date of the entry was given, but no date given when the actual importation took place, that if the lumber arrived in the United States prior to Oct. 30th the decision of the collector must stand, otherwise, the protest of the importer would be well founded, and the entry should be reliquidated accordingly. The decision upon this case will settle the question of the tariff importations made by North Michigan from Canada and some other localities where the matter has been in suspense awaiting the result.

#### CANADIAN DISLOYALTY.

SEVERAL of our exchanges have published a letter signed, "A Commercial Traveller," wherein complaint is made that British Columbians will not buy certain manufactures made in the older provinces, but prefer to deal with houses established in the United States. The complaints are well founded, but the knight of the grip must be a youngster if he had to go across the continent to find purchasers permeated with erroneous ideas of what they term "American" goods. Commercial men about fifteen years ago found it uphill work to make sales in many lines, and even yet when a thoroughly good and honest new Canadian article is put on the market it is viewed with suspicion, and if only a smatter of Yankeeism can be found lurking around it in undiscoverable quantities some tradesmen will buy and palm it off as imported from New York, or Buffalo or Kalamazoo. If no other good resulted from the National Policy of '79, the tariff enactments inaugurated that year compelled Canadians to buy Canadian goods, and forced them into the use of national manufactures. It has taught them that Canadian mechanical contrivances—Canadian mill and factory productions—can be made within our own borders equal to, and in many instances better than importations. So far reaching has this sort of "Americanism" become that it sapped the very vitals of a national spirit, and many a traveller returned to his house wondering if some of his customers would pay fifty cents more per cord for an inferior stock of winter's fuel if a few of the sticks could be labelled "from the other side." The *Bridgewater Enterprise*, a Nova Scotia paper, in its issue of the 18th ult. presents another side of national disintegration. An editorial that lauds the New England markets, and which lamely attempts to show the benefits which would accrue to Canada if there were no tariff says:

"It is enough to say that during the last year the people of Bridgewater and those who buy their supplies in Bridgewater paid in cash to the manufacturers and middlemen of Upper Canada at least \$50,000, and this is only for a small part of the county. In return what did the Upper Canadians leave us. Why their travellers left a few dollars with the hotel proprietors, a few more with the stable keepers and a few more with the railway company."

This is an average specimen of the sentiments of second growth basswood Canadians whom the country could well do without. Spineless as a fishworm, and resembling a mud turtle crawling through a bush backward, they can see no "Balm of Gilead or no physician" in the land that feeds them, but must be continually cringing and begging for support from their imaginary Elysium, the United States.

In spite of the wholesome national training our people have received through the adoption of a policy, its influence has been at work for so brief a period in our history that if discontinued such samples as the *Enterprise* would "return to their idols," and greedily buy from the land of wooden hams and basswood nutmegs. Volumes could be filled of the difficulties surmounted in building up a trade in the manufactures which saw mill men require. It took brains, wealth and push to induce them to try Canadian made leather

belting. At one time in the great centre of our sawn lumber trade, Ottawa, you could not find a foot of Canadian made rubber belting. It was the same in Parry Sound, in the mills bordering on the Georgian Bay, and in Algoma. You couldn't coax mill men to try it, and they never would have allowed a sample inside their mill if New England belting could have been imported.

It was the same in varnishes, mixed paints, in saws and in mill machinery. The remedy, if continued to be applied, will ultimately bring British Columbia into line. She is developing rapidly, and when in a position to offer her manufactures to her sister provinces a little "hoisting with her own petard" will be a grand tonic.

#### QUESTIONS AND ANSWERS.

J. R., Montreal, asks:

(1) Will you give the names of responsible dealers of Yellow Poplar or Whitewood.

(2) In what part of the Dominion are the woods found in our list and who are responsible dealers in the several localities?

(3) We also want information on Mahogany, Chesnut and Veneers.

(1) Correspond with Wm. Sutherland & Co., Nashville, Tenn., J. E. Bates & Co., 1101 Front St., Nashville, Tenn., or Willard W. Brown, 202 Main Street, Buffalo, N. Y.

(2) Quartered oak is not sawn in Canada except in very limited quantities. Red and white oak is found in clumps and specimens in both Ontario and Quebec. Black walnut and hickory, once plentiful in south-western Ontario, is now imported from the U. S. Most of our sycamore is imported, although the Canadian variety can be procured from any of the saw mills along the St. Clair branch of the Michigan Central. Elm, ash, birch and maple can be obtained in many counties. Correspond with Porter, Robertson & Co., Donogh & Oliver, or any wholesale firm in Toronto. Thos. Pinkerton, Pinkerton; B. B. Millar, Warton; Murray Crawford, Campbellville; Cheney, Dunning & Co., Vank-leek Hill, supply manufacturers.

(3) Mahogany and Chesnut are both imported and the same may be of said Veneers.

C. W. Pitt, Little Current, writes:—

Can you give me an idea of how long Oakley township has been lumbered, and an estimate of the amount that has been taken off and any other particulars you may get? Some claim it to be the best township ever lumbered in Ontario. Let us know through your paper if not too much trouble.

Enquiries made at the Department of Crown Lands and other institutions where information of this nature is supposed to be found, fails to throw any positive light on the question. Several old timers have been interviewed, who reply that they have often heard of the township, but as far as definite information is concerned, they know as little about comparative stumpage as they know about about the man in the moon. We are still making enquiries. If we unearth anything we will note it in our next issue.

#### FIRES AND CASUALTIES.

Three men returning to the mainland from Howry's camp, Manitoulin Island, while crossing the ice, with the thermometer registering 20 below zero, were so badly frost bitten, that medical aid was necessary to prevent death.

A man named Thurlow, working at a camp at Howe Sound, was brought to Vancouver, B. C., suffering from broken ribs and internal injuries, from having been crushed between saw logs.

The McLaren mills, comprising saw mills, planing mill, lathe mill machine shop, sash factory, and over 1,000,000 feet of lumber were burned on Sunday the 8th ult. Loss on the mill, \$125,000; very slightly insured. Damage to lumber, \$15,000; fully insured. It is not certain if the firm will rebuild on the same site. Rumor has it that that they may purchase the Gilmour property on the Hull side of the river, or that the property and limits may be sold to outside parties, or rebuild on the old site with brick.

The factory of the Meaford (Ont.) Building and Mfg. Co., has been destroyed. Loss, \$10,000; insurance, \$2,000.

Dodd's planing mill, London, Ont., narrowly escaped being consumed on the 15th ult. The firemen succeeded in confining the flames to the upper flat.

On February 14th, the large saw mill at Shelburne, N. S., owned jointly by Mr. John C. Ryer and Messrs.

John W. Bowen & Sons, was burned to the ground, along with all the sawn lumber in the yard. Loss, \$25,000; no insurance.

Lassaline & Son's furniture factory and store rooms, at Sandwich Ont., were destroyed Feb. 11th. Loss, \$5,000; insurance, \$2,000.

Muirhead & Mann's sash factory, at Victoria, B.C., was partially burned Feb. 2nd.

A young man named Simpson, of Peterboro', Ont., was instantly killed in the Douglas' camp. Cook's mills by a cant hook striking him on the temple.

A boiler exploded, Feb. 20th, in small mill near Madoc, Ont., owned by Frank Castleman. One of his sons was thrown 20 feet and severely scalded. His recovery is very doubtful. Another son escaped with slight injuries. Boiler and building are a complete wreck.

Allan Morrison, of Sarsfield, Ont., was killed while hauling logs to the "roll-way" or "dump" in the township of Cumberland, Russell County.

Following are among the accidents caused by falling trees, which have come under THE LUMBERMAN'S notice during the month:—Robert Torrie, Harkaway, Ont., seriously injured; John Ireland, South Dorchester, Ont., killed; Wm. Caldwell, of Caniley, Ont., leg broken and other injuries; Thos. Somers, killed in Michigan; Geo. Morten, Sturgeon Bay, Ont., killed; W. H. McKibbin, Athole, Ont., killed; Jos. Vian, of Hull, Que., both legs crushed to a pulp.

Accidents in mills during the month have been plentiful. Following are among the number:—David Reed, employed, employed in Martin & Adair's mill, Gorrie, Ont., badly crushed by logs; David Weaver, Doaktown, N. B., badly cut with an axe; John Moran, Sr., Melancthon, Ont., leg broken; John McIntyre, engaged in Dollar's mill, Brunel, Ont., arm mangled; Berton F. Hall, seriously injured in Morrison's mill, Frederickton, N.B.; Constable Lang, Ethel, Ont., cut and bruised in head and face by an edging becoming entangled in a saw; Geo. Sutcliffe, Warren, Ont., foot badly jammed; James Delaney, Thompsonville, Ont., left hand taken off by machinery; Robert McAfee, Alwin, Que., ribs fractured; Henry Traxler, blacksmith in Elgie's mill, Wabash, Ont., instantly killed by a plank being thrown from a saw; Omer Lambert, employed in Morin's mill Lake Temiscamingue, Que., killed.

John Dark, employed in a lumber camp at Monmouth, Ont., attempted suicide by throwing himself under a train. His arm was taken off.

#### TRADE NOTES.

Messrs. F. E. Dixon & Co. of this city recently delivered to the Toronto Electric Light Company the largest leather belt ever manufactured in this province. It is double thickness, thirty-eight inches in width, between ninety and one hundred feet long and weighs nearly six hundred pounds. It is intended to drive the new 400-horse power engine just finished for the Company by the Polson Iron Works Company and runs over a huge fly wheel fifteen feet in diameter. This is the fourth large belt made by Messrs. Dixon & Co. for the Toronto Electric Light Company, the others being each thirty-six inches wide, averaging over one hundred feet long and all double thickness. One of them has been in constant use since 1885 and is apparently as good to-day as when it was first put on.

Robin & Sadler, of Montreal and Toronto, have received the contract for supplying the large main driving belt for E. Tuckett & Son's tobacco factory at Hamilton.

The Dominion Leather Board Co., of Montreal, have purchased the property and water power at Sault au Recollet, near Montreal, formerly owned by McNeven & Co., which consists of saw mill, grist mill and the well known paper mills of the Sault au Recollet Paper Co., and are making extensive alteration there, and will move their leather board and friction board mill there. They will continue to manufacture roofing, sheathing and lining felts in the paper mill.

### SOME BIG LOG HAULING.

FARMERS seem to have forgotten the laying hen and her industry crippled by Bill McKinley, and have turned their attention to other rural matters of greater importance, to judge by the numerous paragraphs found in exchanges. The village of Wroxeter stood at the head of the list for some time, until Wingham scooped in an entire bush. Since the scoop Wroxeter has taken a back seat. Compare the items :

"On Saturday last Dave McBride, teamster for Smith, Malcolm & Gibson, Wroxeter, brought to the saw mill the largest load of logs that has ever entered the town, there being 2,843 feet of green pine in the six logs comprising the load. The pine was brought from Wm. Ferguson's, the above firm having bought his entire swamp."—*Ex.*

"One of the largest, perhaps the largest load of saw logs that was ever brought into Wingham arrived on Saturday afternoon last, for the Union furniture factory. It consisted of 4,538 feet of pine. It was cut in the Factory Co.'s bush in Turnberry, and brought in by Mr. S. Lockridge, with one span of horses."—*Advance.*

You couldn't fool Seaforth on measurements. Her town scales weigh correctly, according to the weighmaster, but they are always too light when a farmer sells hay or cattle, and too heavy when he buys salt or coal. Seaforth weighed her logs as the paragraph will show, and she breathlessly awaits for log weighing reports :

"James Smith, of McKillop, delivered in Seaforth last week a load of wood which brought down the market scales at 9,300 lbs. This is a pretty solid load for one team."

Logs in the East are little fellows around Perth, so says the clipping, and fair to middling around Cornwall until you move west again.

Mr. E. Broughton recently delivered at the Monkton saw mill, the largest pine log delivered there this season. Six hundred feet of lumber were sawed from it.

The Cornwall *Standard* says: "Two monster pine tree trunks were drawn into that town, one of which measured 5 feet at the butt and 26 inches at the top, and was 96 feet long, while the other was 80 feet long, 4 feet 3 inches at the base and 23 inches at top. It required seven teams of horses to draw the former, and five teams for the latter."

Bracebridge had a log that yielded one and one-third more than Monkton's pole. It took three Plymouth maple logs to equal the Bracebridge pine, and Holbrook topped the list with a monster.

A pine tree cut near Bracebridge measured 5 feet across the stump, and the first log contained about 1,400 feet. \* \* \* A big tree was drawn in to the McAuslands saw mill last week by John McMann. The tree was hard maple and girt 10 feet at the butt. Three saw logs 12 feet long were got out of it, making 1,608 feet of lumber, while seven cords of stove wood were made from the balance of the tree.

The largest tree ever felled in the vicinity of Holbrook, was sawn into logs last month. It measured 5 ft. 10½ in. across the end of the second length.

Tamworth is not to be outdone by big log hauling or dimensions. She branches out into the realms of science and sends the following contribution

At Tamworth recently a rock maple tree was cut, in the heart of which, eight feet from the ground, was found a rock which weighed five and three-quarter pounds. This wood was solid and healthy all around the rock, and the tree was three feet through at the place where the rock was found.

### THE ENGLISH TIMBER TRADE.

The *Timber Trades Journal*, London, Eng., issued Feb. 7th., gives many facts, suggestions, and speculations regarding the timber trade for 1891. Shippers to the United Kingdom reading over extracts can form their own opinions, and base their logging on the present tone of the market.

If the demand in Great Britain does not exceed that of 1890, if shippers continue glutting the market the state of trade at the end of the year can only be called dull. It says :

"We are continually being questioned as to the present position of the wood trade generally, and what is going to be the result of all the failures which the month of January brought in its train. Now it is a very difficult thing to come to any conclusion on this knotty point, as a great many unforeseen events may happen to give a different colouring to the present decidedly unfavorable outlook. Still, accepting things as they now present themselves, we see nothing as yet to prevent the season of 1891 being a good one for buyers on this side. It is very well for producers to tell us that they cannot reduce their prices any lower, as already they are below cost, but the old law of supply and demand, which has been violated for so many years back, is beginning to come to the surface again, and those who have ignored it for so long must now recognise its power. If our markets, as they undoubtedly are now, continue in a state of surfeit, the demand for fresh importations must diminish, and the foreign shippers or mill-owners will have either to keep their goods or sell them here for the best prices they can get under the circumstances."

The commercial condition of Great Britain during

1890 interfered with every channel of trade. The stagnation in lumber was not the only stagnation. Local yet widespread industrial difficulties in manufacturing centres had a bearish effect on timber; the financial upheaval in the metropolis in the latter months of the year had a marked depressing effect; while the railway strikes added their quota to the general inactivity. During the past month ship cargoes to the U. K. have decreased except from Canada, and stocks on hand have been slowly working off. Reports from the Baltic state that the supply of logs upon the Swedish shore and tributary streams, awaiting the opening of navigation, are less than for the corresponding month of last year.

Speaking of the decline in prices during the period of February 1890 to February 1891 in Archangel deals, the *Journal* says :

"What has brought about this great decline in prices? We can trace it to no other cause than the enormous quantity of goods shipped during 1889 and 1890. This is corroborated by the decline having extended to the Canadian goods as well as those from the Southern States of America. We can well understand the anxiety of shippers' agents to take advantage of the confidence betrayed by importers in the reports of a moderation in the production. The combination to limit the production is a very fair argument to trade upon, but we must first see some fruits of its working before we advise our friends to place any confidence in it. Quite possible 1891 may in the teeth of these protestations witness as heavy a stock as any of its predecessors. If, as some maintain, the growth of the population is followed by a proportionately increased consumption, then let them at the same time call to mind the great increase in the means of production which annually springs into growth. Hundreds of saw mills are running now to manufacture wood for the markets of the world, the consuming powers of which are greatly overrated, and the evil consequences of which falls on the markets of the United Kingdom, where the over-production is invariably sent when other places fail. Of this we have had examples over and over again, and though we shall be glad to see an alteration, we are by no means sanguine that this year will witness it."

The Board of Trade returns for the month of January, 1891, analysed, show that Norway and Sweden decreased shipments as compared with January, 1890, by 1,959 loads, Russia, 10,938 loads, Germany a heavy decrease, while Canadian imports more than doubled themselves. If the returns for the past month and the current month show the same decrease for other nation's exports, and the same increase for Canadian, it is possible that eastern shippers may hit the market at the proper time for the balance of their last season's cutting, but the "surfeit" of which no uncertain warning is given by the *Timber Trades Journal* must not be lost sight of.

### CARE OF MILLS IN WINTER.

OF the large number of saw mills in the United States and Canada, probably two-thirds of them are "laid up," during the winter, an average of four and a half months. It is a commonly received opinion that, at the best, mill property deteriorates quite as rapidly while idle as when in operation. The reason for this is obvious to the practical mechanic. If it be true under the most favorable condition, such as laying up the mill in first-class shape, what shall be said of the large number of mills which are "laid up" simply by blowing up the boilers and emptying such steam and water pipes as happen to be thought of at the time?

Most of the large, first-class mills which shut down during the winter, are of course put in the best possible shape, but a large number, mostly small, are left in a condition of the utmost neglect.

An actual instance will illustrate the point. In Lake County, Mich., there is a cheap, semi-portable circular, with gang edger and butting saw, the outfit having a capacity of about 15,000 feet daily.

The mill shut down for the season November 29th, which was Saturday, and on that day it was run till 5 o'clock p.m., to complete a contract. The engineer, was ordered to blow off, and see that there was nothing left to freeze up. All hands, except one one-man-of-all-work, were discharged and paid off. The engineer, whose home was at a distance, was anxious to get away on a night train, and told the man left in charge, as well as he could in his limited time, what to do.

The next day being Sunday nothing was done. The weather was cold, and when the man went back Monday, several of the pipes that could only be freed by being disconnected, were frozen and burst. The owner was not a practical mill man, lived in another county,

and, withal, was very busy settling up his season's business. He looked around the mill a little, and told the man to fix things up, nail up the mill, etc., which having been done, he left for the winter.

The result was that the frozen pipes were disconnected and the doors and windows were nailed up. The boiler was not washed out, and the old scale and mud were left to eat into and rust the flues and shells. The grate was not cleared out, neither was the mud-drum. The cylinder of the engine was left just as the last turn of the crank left the piston, with the condensed steam left in. The saw was allowed to remain on the mandrel, and the belts on the pulleys.

It is easy to imagine what the condition of that mill will be when the crew gets back next April to start up for the season. The amount of repairs required, caused by neglect, will amount to ten times as much as would have been required to lay the mill up properly.

This may be a slightly extreme case, but it is not much overdrawn in its application to hundreds of saw mills laid up at the end of the season. And it is a fact that many a failure, many a cause of a mill changing hands can be traced to this want of care of the mill while idle.

A few rules, as laid down by a practical mill man of long experience, may not be out of place, and it would be a good thing for these happy-go-lucky, slovenly mill owners to paste them in their hats.

1—Blow off the boiler with sufficient head of steam to carry off all sediment as much as possible, wash out with cold water, scrape all scales off the shell, clean the flues thoroughly, and if possible get the pressure, wash both flues and shell with a hose, and don't forget the mud-drum and heater.

2—Clean the grate bars and ash pit, for nothing will destroy the bars quicker than damp ashes. Ashes left on the grate will collect moisture all winter. After all is clean, build a light fire to dry everything as much as possible, and if a canvas can not be put over the top of the smoke stack, repeat the fire at least once a week.

3—Disconnect all steam and water pipes which will not drain readily, and empty all water tanks and reservoirs not needed for fire protection.

4—Take off the cylinder heads, open the valve chamber, and see that all parts are wiped dry and oiled.

5—As a general rule it is best to take all the belts from the pulleys, roll them up, tag them properly, and put them in a dry place. Where the belts are leather, it is best to oil them, and leave them stretched out full length for a few days before they are rolled. It is a disputed point whether it benefits a rubber belt to oil it. If it is not practicable to take off all the heavy belts, then the pulleys should be given a turn at least once a week to give the belt air, and all tightness should be slackened.

6—Journal boxes should be uncovered and cleaned.

7—All machinery or tackle about the mill, that is under any strain, should be slackened, if possible.

8—The bright parts of the machinery, and the inside of the engine cylinders, should be coated with some substance to prevent rust. A good preparation is made as follows: Equal parts, by weight, of the best fine, dry whiting, and dry ground graphite, mixed with equal parts of raw linseed oil and petroleum, just thick enough to cover. Apply evenly with a brush. It will not dry hard for a long time, and may be easily wiped off in the spring. Should it stick, a little benzine or alcohol will remove it easily.

9—The saws should be thoroughly cleaned of gum, with benzine or turpentine.

10—See to it that neither rain or snow can drive in through the doors, windows or cracks, on to the machinery.

Other things to do will suggest themselves while carrying out the preceding rules.

Many a small mill owner would find a material addition to his account of profit at the end of the year, if he would take proper care of his mill during the idle season.—*Northwestern Lumberman.*

—Napaneé, Newburgh and Camden East pulp mills have stopped buying wood, enough having been purchased to tax their capacity.



**IMPORTS OF THE UNITED KINGDOM.**

THE excerpts following are compiled from the annual wood circular of James Smith & Co., Liverpool, Eng. To readers fond of statistics a perusal of the tables will show Canadian exports in detail and foreign imports gross. The arrivals and Board of Trade returns give our comparative standing with other competitors in the trade:

IMPORTATION.	1886.		1887.		1888.		1889.		1890.	
	Colonial Timber	Deals, &c.	Colonial Timber	Deals, &c.	Colonial Timber	Deals, &c.	Colonial Timber	Deals, &c.	Colonial Timber	Deals, &c.
Total Colonial, in cubic feet	16,724,000	16,161,000	16,724,000	16,161,000	18,232,000	26,004,000	20,628,000	20,628,000	14,136,000	14,644,000
Total Foreign, in cubic feet	9,323,000	11,230,000	12,432,000	16,042,000	16,042,000	16,042,000	16,042,000	16,042,000	16,042,000	16,042,000
CONSUMPTION.										
Colonial Timber	2,725,000	2,497,000	2,957,000	3,519,000	3,425,000	3,425,000	3,425,000	3,425,000	3,425,000	3,425,000
Deals, &c.	14,999,000	14,709,000	16,359,000	19,215,000	16,359,000	19,215,000	16,359,000	19,215,000	16,359,000	19,215,000
Total Colonial, in cubic feet	17,094,000	17,206,000	19,316,000	22,734,000	19,316,000	22,734,000	19,316,000	22,734,000	19,316,000	22,734,000
Total Foreign, in cubic feet	10,513,000	10,803,000	12,886,000	14,279,000	12,886,000	14,279,000	12,886,000	14,279,000	12,886,000	14,279,000
STOCK.										
Colonial Timber	949,000	853,000	748,000	1,391,000	1,391,000	1,391,000	1,391,000	1,391,000	1,391,000	1,391,000
Deals, &c.	4,140,000	3,191,000	2,212,000	4,839,000	2,212,000	4,839,000	2,212,000	4,839,000	2,212,000	4,839,000
Total Colonial, in cubic feet	5,089,000	4,044,000	2,960,000	6,230,000	2,960,000	6,230,000	2,960,000	6,230,000	2,960,000	6,230,000
Total Foreign, in cubic feet	1,917,000	2,344,000	1,890,000	3,653,000	1,890,000	3,653,000	1,890,000	3,653,000	1,890,000	3,653,000

**COLONIAL WOODS.**

**Quebec Oak.**—The stock is much too heavy, viz., 232,000 feet, against 116,000 in 1890. Prices have varied from 2s 6d to 2s 10d per foot. The wood has to compete more and more each year with the wood shipped from the Southern States, which now comes forward in better quality and of better manufacture than formerly.

**Red Pine.**—The stock is not heavy, but quite sufficient for the small demand for this wood. It has been sold at 18d per foot, but the competition it has to contend with in Pitch Pine, which is so much cheaper, almost excludes it from the market.

**Elm.**—The stock is a reasonable one, being only 27,000 feet, against 53,000 at the end of the previous year, but the latter was an excessive quantity. In September, 60 feet average, was sold at 2s 1d per foot, and in November, 50 feet average, realized 1s 11d per foot.

**Ash.**—has been dull of sale throughout the year. By auction in May, 15 inches average, realized 2s per foot, and 13½ inches average, realizing 20d per foot. In the autumn a parcel of 14 inches average was bought at 18½d per foot. The stock is sufficient, and during the past month a rather better inquiry was experienced.

**Birch.**—A very unsatisfactory year has been passed for this wood. It commenced with an unusually heavy stock, but with an average consumption, and Halifax logs were then sold at from 17½d to 22d per foot. In the early autumn Quebec logs, 15 inches average, realized 17d per foot, and St. John, 14 inches average, 16½d per foot, while another poorer parcel of 14½ inches average was sold at 16d per foot. Latterly prices have shown an upward tendency and Dalhousie logs 12½ inches average, have been sold at 14d per foot, and there is now a better consumption. Planks have displayed a weakening tendency from the commencement until near the close of the year and have fallen from £8 5s to as low as £6 5s per standard. There is now more inquiry, particularly from the Tinsplate districts, and values are from £7 5s to £7 10s per standard.

**Hickory.**—is sufficient in stock, and has been in fair demand during the year.

**Cherrywood.**—is not much inquired for, and the stock is now exhausted. No transactions have been reported during the year.

**Quebec Pine Deals.**—The stock has been ample

during the year and although rather less than in 1890, being 5,787 standards against 6,447 standards, it is still more than an average stock. Prices opened at about £19 to £20 10s for firsts, £7 10s per standard for seconds, and £9 for thirds, and fell to about £18 10s, £14 and £8 respectively in the autumn. A rather better demand is now being felt, but values show but little improvement.

**Quebec Spruce Deals.**—have been imported to a larger extent than in previous years, chiefly by steamers, and have been sold at £5 17s 6d to £6 5s per standard, ex quay.

**Boards and Sidings.**—have followed the course of Deals at the usual differences in prices, and the stock is sufficient for all ordinary purposes.

**New Brunswick and Nova Scotia Deals.**—opened with a full stock, a good demand and firm prices. At the commencement of the year sales of St. John were made at £9 10s per standard, c.i.f., and lower ports at £7 7s 6d, Bay Verte at £6 15s per standard, and considerable business for spring shipment was done at about these figures. Freights opened at a reasonable basis, and a little fall was anticipated from the rates ruling in January. The consumption, however, in the spring proved unsatisfactory. Considerable pressure to realize was shown by merchants, some buyers who had not contracted made great efforts to force prices down, with the collapse of the South American demand for tonnage a larger number of vessels were brought into the wood business and rates commenced to decline; all these circumstances tended to depress values with the result that in July and August St. John Deals were selling at £6 10s, Lower Ports at £6 to £6 5s and Bay Verte at £5 10s, c.i.f. Latterly, sales have been of Hillsboro Deals at £5 10s, Dalhousie at £5 15s, and St. John, 11x3 at £7 15s, 9x3 at £6 5s, all ex quay. Battens are difficult to sell. Sales are now hard to effect, and buyers ideas for St. John are about £6, Bay Verte about £5 5s; few contracts appear to have been made, sellers being disinclined to accept such figures. Stocks are ample, being 20,767 standards against 17,838 standards in 1890, the latter was considered heavy.

**Scantlings and Boards.**—are quite sufficient for the demand, which has been fair during the year at the usual reduction off the price of Deals.

**New Brunswick and Nova Scotia Pine Deals.**—show a stock of 1,426 standards, against 1,094 standards in 1890, which is fully sufficient for any reasonable demand.

**Quebec Staves.**—have been imported sparingly and the stock is merely nominal.

**Masts and Spars.**—are not imported now. The increasing use of iron and steel for shipbuilding purposes is quite thrusting these importations out of the market.

**Lathwood.**—seldom comes forward. The stock is quite exhausted.

**Palings and Lath.**—have been inquired for during the year, but the stock of palings is now much too heavy; they having realized from 50s to 55s per mille.

**LIVERPOOL IMPORTATIONS FOR FIFTEEN YEARS.**

Year ending the Import season of	Vessels	Tonnage	Pitch Pine.		Baltic.	
			Est. Ton.	Vessels	Tonnage	
1876	521	394,907	69,399	222	85,607	
1877	468	391,952	80,006	227	93,463	
1878	359	269,343	48,665	177	66,591	
1879	296	229,334	41,044	157	61,502	
1880	424	332,875	58,972	245	96,567	
1881	318	242,169	69,834	153	63,400	
1882	369	285,469	82,555	234	100,722	
1883	393	310,578	58,509	254	109,654	
1884	353	256,841	63,452	214	91,183	
1885	343	240,865	70,947	226	103,872	
1886	331	226,631	39,052	245	111,758	
1887	282	212,700	52,989	244	112,502	
1888	307	239,565	50,301	253	130,162	
1889	370	316,940	80,698	264	146,853	
1890	358	262,954	79,639	262	135,618	

**BOARD OF TRADE RETURNS FOR 1889 AND 1890.**

	HEWNN TIMBER.			
	Quantity.		Value.	
	Loads.	Loads.	£	£
Russia	363,956	316,952	661,041	534,366
Sweden & Norway	736,028	673,305	1,099,813	946,599
Germany	285,922	287,482	720,995	727,352
United States	148,605	151,697	633,832	615,140
British E. Indies	57,589	46,937	690,025	528,450
British N. America	227,229	180,066	1,149,784	883,461
Other Countries	570,162	621,935	679,628	769,186
Total	2,389,491	2,278,374	5,635,118	5,004,554

	SAWN, PLANED OR DRESSED		Quantity.		Value.	
	Loads.	Loads.	£	£	£	£
Russia	1,476,165	1,202,222	3,386,469	2,500,000	2,500,000	2,500,000
Sweden & Norway	2,166,028	1,970,361	4,926,917	4,300,000	4,300,000	4,300,000
United States	379,536	308,424	1,218,957	9,200,000	9,200,000	9,200,000
British N. America	1,233,750	1,185,205	3,257,527	2,900,000	2,900,000	2,900,000
Other Countries	123,271	112,192	352,463	300,000	300,000	300,000
Total	5,318,750	4,778,314	13,142,333	11,000,000	11,000,000	11,000,000

**TO DO AWAY WITH THE SAW MILL.**

THE days of the saw mill are numbered again. This time it is a California genius who has invented a machine for the purpose. It is thus described: This invention is entirely new and novel, and is designed to take the place of the costly saw mill. It is portable in its nature, and the operator can go to a saw log, set the device in position and proceed to evolve boards. A fixed guide rail is provided consisting of an oblong plate, having oppositely beveled top and bottom edges, and a central longitudinal strengthening rib. To this guide rail are secured the two fixed bearing blocks, having on their lower ends piercing points. Through one side of the blocks pass the holding screws or screw bolts, the tops of which are provided with wrench holds, whereby the ends of the screw bolts may be projected below the blocks in order to fix them to the log. In the upper portion of these blocks are freely pivoted the swinging tubular holders, in which are inserted adjustably, the shanks of the dogs, said shanks being held in position by set screws, which enable the dogs to be set in or out for the purpose of accurately placing and holding the guide rail in a perpendicular position. Upon the beveled top and bottom edges of the guide rail is mounted, by corresponding bevells, the sliding carrier. The outer face of this carrier has a vertical bevel-sided groove or seat made in it, in which the bit plate is fitted. The lower end of this bit plate is provided or has connected with it the bit or knife. This is a double ended one, having planing points at each end, and at its middle the scoring cutting edges for cutting the sides of the shaving, the scoring edges being carried down below the horizontal plane of the points, so that they will score the wood on the previous movement of the knife or bit before its planing points cut the shaving out. At the top of the bit plate is formed or secured a nut, in which is seated the vertical screw, the lower end of which is properly stepped in the sliding carrier. The lower end of the screw is provided with a ratchet wheel or disk, the teeth of which engage with a fixed rack, one at each end, the body of which is secured to the fixed guide rail. Any suitable means may be employed to move the carrier back and forth along the fixed guide rail. The operation is as follows: It is intended to be mounted on a log, and held firmly by turning down the screw bolts of the bearing blocks, so that their points will enter the log; but it is temporarily held in position before and while these bolts are being screwed down by the holding points of the blocks, which penetrate the wood from the weight of the machine. The whole device is further and securely held to the log by the dogs, which, on account of their adjustment are adapted to throw the guide rail into a perpendicular position. When everything is ready, the carrier is drawn back and forth on the guide rail. On the trip over, the scoring edges of the bit cut on each side, while on the trip back the planing point cuts out the shaving, while the scoring edges cut deeper for the next shaving. On the forward trip again, the other point cuts out the shaving, while the scoring edges cut deeper into the sides again. Now at each trip of the carriage, the bit is fed down to its work. This is effected by the ratchet wheel of the screw coming in contact with the fixed racks at the ends of the machine. This makes an even and positive feed, so that when the device is adjusted to the work, the operators have nothing to do but draw the cutter slide back and forth along the guide bar until the new board drops off.

—Favorable weather up to date, has allowed the different shanties of the Rathbun Co., of Deseronto, to make good headway with their intended supply of logs.

## HOME AND FOREIGN TRADE REVIEW.

Office of CANADA LUMBERMAN,  
FEB. 28th, 1891.

LOCALLY, the lumber trade has been quiet, as it usually has been during the month of February in past years. Dealers' reports show that as many feet have changed hands as in the corresponding month last year. The bulk of consumers are buying for inside finishing, a great deal of which is for delayed contracts, so that with little outside building it is not to be wondered at that sales are termed quiet.

Permits have been granted for the erection of a few good sized buildings for the coming season, but the activity that prevailed in architects' offices in the February months of 1888 and 1889 is not so apparent. Unless rentals improve there will not be the same run on dwelling house erection that caused the demand for certain classes of sawn timber during the past six years, but it is expected that alterations, modernizing of centrally situated buildings, and new structures will even up matters.

Future contracts have been placed for quantities with some dealers, but in general speculators, contractors and builders are waiting to see how the early season opens.

Enquiries from our markets in the United States are numerous, particularly for hardwoods, but shipments are almost *nil*. Dry stocks are not procurable, and as the orders booked are for seasoned lumber, some time must elapse before shipments can be made. Selected stock is asked for by United States jobbers in New York state, and many ledgers show contra purchases for yard orders as a make shift until the cold season is over. Canadian sellers could dispose of an unlimited quantity of choice or best grade of all sizes at present. It cannot be obtained on a days notice, and as in many instances the opportunity is a catch sale, little, if any, number one stock will change ownership.

A few car lots of culls and special sizes have gone south and south-east into New York state, but the movements have been slow. Wholesale and retail prices are unaltered. Canadian exports in sawn lumber to the United States for January, 1891, exceeded that of January, 1890, by \$53,000. Up to the 15th of last month the quantity shipped was slightly in excess of the corresponding period of last year. Could we turn prophetic and proclaim increased exports for the next ten months, the drain upon the unmanufactured cut of Canadian timber would cause a boom in the winter season of 1891 and 1892. When the negotiations were pending, which resulted in the repeal of the Canadian export duty on logs, and the partial repeal of the import duty levied by the United States on lumber, it was urged that Canada had got the better terms. It was claimed by those largely interested in the trade, but not affected by the tariff laws, that the removal of the export duty benefitted only a few Michigan and Canadian limit owners who were the prime movers and lobbyists in the Washington Capitol and in Ottawa. United States dealers and papers published voicing their beliefs, positively aver that the reduction of the import duty did not lessen the cost to consumers in the United States one cent. Further on a meagre epitome of the logging in Canada this season will give a fair estimate of the opinions held by the bulk of Canadian limit holders, touching the supposed benefits from the reduction for '91, not in words but in deeds. Speaking on the subject of reciprocity as existing, and as proposed by the Dominion Government, J. R. Booth, of Ottawa, says: "No doubt reciprocity would do the lumber trade good, but you know the trouble with us just now is not what we can sell lumber for, but what others can sell it for. If United States lumbermen can sell at a certain price below our own, we must come to that price or do no business. It has got to be so now that we cannot compete with southern pine, which is placed in all the northern and eastern markets at from \$2 to \$5 less than we can do it, but of course the \$1 of duty off will help us some. With the duty off the Chaudiere lumbermen would not fear competition with the Michigan lumbermen, but they would still find Southern pine and negro labor a hard nut to crack. It is only about five years since the Southern pine was introduced into the north and east, and now it is being used more and more every year. Before the Michigan and Wisconsin lumbermen took up the manufacture of it trade in it did not amount to anything, but as soon as they went into this trade, with their experience and business push, the business began to flourish, and now has every prospect of continuing to do so. They buy the land at \$1 an acre, and as the timber is abundant and within easy reach, they can sell at a very low figure and yet make money. They cut down the trees, dry the timber, plane it, and send it north and east ready for building, at prices which Canadians could not touch. At present things look blue for the Canadian lumbermen. What would be the result of the Southern pine competition he was not prepared at present to say."

Speaking on the same question, ex-alderman L. Crannell, of the Bronson & Weston Co., of the same city, says: "I believe reciprocity would benefit the lumber trade, and I will explain to you in a few words

how it would do so. At present pine lumber going into the States from Canada pays a U. S. import duty of \$1 per thousand feet, and as a result U. S. lumbermen buying in Canada have to pay a dollar more laid down in the States than they would if purchased from the Michigan or other manufacturers. As the Michigan men by reason of their larger output control the New York and other eastern markets and fix the price, we have to reduce the price of our lumber so as to be able to compete with them. For instance, if the price for the commoner grade, which is that shipped almost entirely to the U. S. market, is quoted by the western men at say \$10, we have to sell at \$9 here so as to be able to compete with them, or the middleman has to lessen the margin of his profit. If the \$1 of duty per thousand feet was off, we would be able to do business on equal terms with the Michigan men, as we are so geographically situated that we can supply the eastern states better than the western men can do. That there would be an increase in the sale of Canadian lumber I am sure, but I am not prepared to offer the slightest estimate of what the money value of that increase would be. Of course there is no such thing as reciprocity in lumber, as we are sellers, but do not buy. Canada does not get a stick of manufactured lumber from the States." Mr. Crannell added that of the total of 700,000,000 feet of all kinds of lumber manufactured in Ottawa last year, about one-third went to the States, a third to the old country and the other third to South America. In 1889 when trade was a fair average the lumber shipped to the States from Ottawa netted about three and a half million dollars.

The rates offered by the Canada Atlantic railroad are to hand. The circular reads as follows:

Arrangements have been made whereby we will reopen our lumber line to New York, via Albany, with the opening of navigation on the Hudson, which took place last year about March 10. We will be unable to send you a copy of our tariff with the exact date to take effect until the opening of navigation has determined itself, but the following are the rates at which we will open the line, namely: Seasoned pine lumber, \$3 per thousand feet; seasoned shorts, \$3.25 per thousand feet; lath, 65 cents per thousand pieces; seasoned hardwood lumber, \$4 per thousand feet.

These rates will apply on lots of five cars and over, and will include lighterage within the regular lighterage limits of New York harbor. Lots under five cars will be accepted subject to extra tonnage.

Capt. Williams, of Albany, who handled the lumber from Albany down last year, will also be in charge this coming season.

Reports received from the logging camps in the Ottawa Valley and the Georgian Bay districts state that operations have ceased in many localities. At some points the snow has been so deep that the cutting of logs had to be discontinued. In others the desired quantities have been cut and banked, and the teams have either returned or are on their way southward. Eddy & Co., Pierce & Co., and McClyment & Co., have lumbered this season. Their mills will be practically idle next summer, along with the burnt McLaren & Co.'s mill. Other mills, to a certain extent, will have to supply their usual cut, and if the demand for white pine is unusually brisk, it means day and night shifts until the mills close in the fall. If the intended contracts on the north shore of Georgian Bay and Lake Huron are filled before the end of the month, 200,000,000 feet will be piled up waiting for open water and purchasers. Of this, fully 75,000,000 feet will be rafted to its owners at Tawas and Saginaw, and to buyers of Canadian logs in Alpena and Cheboygan. In addition to saw logs immense quantities of birch, cherry, basswood and pulp wood have been cut, some on contract and some on speculation.

In New Brunswick, on the St. John river and tributary streams, the supply will fall short of 1890. Last year the Fredericton boom held 135,000,000 feet of logs, while on the river and branches, fully 50,000,000 feet was left. This year the estimated quantity to drive will not exceed 95,000,000 feet. In Nova Scotia, at Herbert river and Neville, a greater cut has been banked, but on several streams operations have been curtailed.

## UNITED STATES.

In looking over the reports upon the conditions of the trade amongst our United States brethren, at least that part of them who purchase from Canada, monotony is the striking feature. Sales are not being made to dealers who flirt with future prices, uncertain weather has checked building to a great extent, and no lumber centre has to hustle to keep up with booked orders. The actual daily requirements keep a steady, though quiet tone in all the markets, and except when specials unexpectedly are asked for, no activity can be noticed. Hesitation, with expectancy of a good spring trade describes the situation. As to the future of values, two leading opinions are current: The first, that the effort put forth in the west—for better prices—will be met and nicely balanced by the influences of recent Canadian legislation on the lumber question. The prevailing feeling, however, is that really choice stock is destined to show a stiffening in price. Ex-

porters feel decidedly well over the Brazilian reciprocity scheme, and believe that its influence will be to speedily increase the already good Brazilian demand.

We notice amongst the failures that the wholesale lumber firm of L. Thomson & Co., Albany, N.Y., have made a general assignment to their bookkeeper, Richard T. Lockley. Mr. Thomson was at one time a member of an Ottawa lumber firm and always looked upon as wealthy. Assets and liabilities unknown. Statement of debtors and creditors not yet published.

The Buffalo Lumber Exchange, at its meeting on the 14th, discussed and strongly condemned the late resolution passed by Saginaw vessel owners who have agreed during the incoming season not to load or deliver any cargoes except from or on rail. Deliveries on railroad docks alone in Buffalo means extra men, extra handling means increase in the cost and probably loss in the selling. A determined resistance was the voice of the meeting. At the same time, the friction that existed between planing mills and the wholesaler was eased by the latter accepting the terms and propositions of the former. For some time back there have been mutterings of discontent about the practice of the jobber selling contractors, builders and other retail consumers at wholesale figures. The planing mill men insisted that the practice be stopped, particularly in the case where the jobber has a mill and a yard. In future, retailers buying from wholesalers, whether planing mill men or yard men, will have to pay retail prices. In case of non-compliance by a jobber he will be boycotted.

All the best grades of lumber are scarce and held firm. Long bill stuff, posts, piles and square timber are asked for. Prices are adhered to, the existing conditions of trade indicating that present stocks will be satisfactorily disposed of before new lumber can be marketed fit for use. Buffalo and Tonawanda markets are *one*. The wholesale price list of both places is a joint one, the rates of freight by rail, by canal and water are the same, and they purchase and sell in the same markets. Sales for February exceeded January, particularly in hardwoods. Like Buffalo, the outlook for vessel charters is not encouraging. Assortments of pine lumber are badly broken into, cutting up and better are depleted, and they are likely to remain so until the opening of navigation.

It is expected that the spring of the year will liven trade in the New York yards by the demands for projected buildings in the upper part of the city, Brooklyn, Jersey City and Long Island suburbs. At present, things are dull. Dealers are fairly well stocked, and as little desire exists to increase the quantities now on hand, large importations are not demanded, and agents are having a quiet time. White pine is steady, the prices unchanged, and the holdings with new arrivals, just sufficient to even supply and demand. The future of the season is yet obscure, but nothing is left undone in eliciting information about where purchases can be made, and what the freight rates will be for the current year by rail and water, both premonitions of an expected good season's trade.

William Westby, Portland, Me., correspondent of the Sherbrooke *Examiner* says: Another very quiet week has been experienced in the lumber trade, and the market is no better than has been previously reported. Spruce lumber is not wanted, as this stormy weather checks all work and prices are low and easy. Random cargoes are received now and then and they bring prices quoted a shade lower than are asked for carload lots. Hemlock boards are also dull as well as everything else in the line of boards and long lumber.

The yards are well stocked and concessions are made to effect sales. Clapboards look a trifle better but the improvement is not sufficient to stiffen prices materially.

Shingles are dull and prices easy and the demand slow. Most of our salesmen report this month so far that orders are scarce and hard to obtain.

The mills are getting in a fair supply of logs and the prospect is that the usual quantity of logs will be got out.

South American lumber is still dull and no prospect of any movement in it. Many vessels are lying here awaiting freight.

## FOREIGN.

We have commented elsewhere on the state of the United Kingdom markets. Since setting up the excerpts from Gray & Sons annual timber circular, other well known firms have corroborated the warnings by the *Timber Trades Journal*.

Business during the past year, say Farnworth & Jardine, has been unsatisfactory in most branches of the wood trade. The aggregate import, although showing a reduction of 17½ per cent. from the excessive one of last season, has still been in excess of the five previous years, and more than ample for the demand. The deliveries of most articles have been disappointing, the total consumption being 7 per cent. less than last year. The stocks now remaining over are much too heavy. The outlook is not encouraging, and, with the large stocks held over, shippers must see it is most important that supplies be kept on a moderate scale.

TRADE REVIEW.

Toronto, Ont.

TORONTO, Feb. 28, 1891.

CAR OR CARGO LOTS.

Table listing lumber prices for Toronto, Ont. including items like 1 & 1 1/2 in. cut up and better, 1x10 & 12 dressing and better, etc.

YARD QUOTATIONS.

Table listing yard quotations for Toronto, Ont. including items like Mill cull boards & scantling, Shipping cull boards, Scantling & joist, etc.

Hamilton, Ont.

HAMILTON, Feb. 26, 1891.

Table listing lumber prices for Hamilton, Ont. including items like Mill cull boards and scantlings, Shipping cull boards, Scantling and joist up, etc.

Ottawa, Ont.

OTTAWA, Feb. 28, 1891.

Table listing lumber prices for Ottawa, Ont. including items like Pine, 1st qual., 2nd, shipping culls, etc.

Montreal, Que.

MONTREAL, Feb. 28, 1891.

Table listing lumber prices for Montreal, Que. including items like Pine, 1st quality, 2nd, shipping culls, etc.

St. John, N. B.

ST. JOHN, Feb. 24, 1891.

Table listing lumber prices for St. John, N. B. including items like Deals, Boards, Scantling, etc.

Vancouver and New Westminster, B.C.

NEW WESTMINSTER, Jan. 17, 1891.

Table listing lumber prices for Vancouver and New Westminster, B.C. including items like Car load and ship rates, Wharf Plank and Timber, etc.

Albany, N. Y.

ALBANY, N.Y., Feb. 28, 1891.

Table listing lumber prices for Albany, N. Y. including items like Boards, 1x10 in. each, Joist 4x6, etc.

Buffalo and Tonawanda, N. Y.

BUFFALO, Feb. 26, 1891.

Table listing lumber prices for Buffalo and Tonawanda, N. Y. including items like Clear, 1 in. & clear, Dressing, 1 to 2 in., etc.

Saginaw, Mich.

EAST SAGINAW, Feb. 28, 1891.

Table listing lumber prices for Saginaw, Mich. including items like CARGO LOTS, Uppers, Common, etc.

New York City

NEW YORK, Feb. 27, 1891.

Table listing lumber prices for New York City including items like Black Walnut, Poplar or White Wood, Oak, etc.

Boston, Mass.

BOSTON, Feb. 28, 1891.

Table listing lumber prices for Boston, Mass. including items like Western Pine, Eastern Pine, Spruce, etc.

Oswego, N. Y.

OSWEGO, Feb. 28, 1891.

Table listing lumber prices for Oswego, N. Y. including items like Three uppers, Pickings, etc.



**WANTED AND FOR SALE.**

Advertisements will be inserted in this department at the rate of 15 cents per line each insertion. When four or more consecutive insertions are ordered a discount of 25 per cent. will be allowed. This notice shows the width of the line, and is set in Nonpareil type. Advertisements must be received not later than the 27th of each month to insure insertion in the following issue.

**HARDWOOD** lumber, bought, sold or received on consignment, TUCKER DAVID, lumber commission merchant, 202 Eleventh Ave., N.Y.

**WANTED—TO BUY.**

**GOOD** Canadian Timber Limits and Georgian Bay saw logs. Address, BEN BIRDSALL, Whitney Building, Detroit, Mich.

**CAPITAL WANTED.**

**WANTED** A partner with about \$12,000 capital, to take half interest in a well established lumber and shingle business in British Columbia. Timber Limits now secured to run mill 5 to 7 years. For particulars address, H. H. S., BOX 297, Vancouver, B. C.

**WANTED—PARTNER**

**WITH** \$50,000 to \$75,000 capital to invest in timber limit and saw mills on line of C.P.R. in British Columbia, with three practical men. Best thing on line of C.P.R. Address BOX 276, Trenton, Ont., Canada.

**WANTED—FOR CASH—HARDWOOD**

**HARDWOOD** Lumber Squares and Dimension Stock, principally wa' nut squares, 12 to 7 in. thick 12 in. and upward long. Apply for specifications and prices. State full particulars of stock on hand. P. O. BOX 1,144, New York.

**FOR SALE.**

**PAIR TWIN ENGINES**, 6x6, with link motion, suitable for rope feed, in order. HADDON, Foxmead, Ont.

**WANTED IN 1891.**

**ANY QUANTITY OF CEDAR TELEGRAPH POLES** at shipping points. Terms cash. Apply to J. HARRISON HARVEY, Cobocok, Ont., purchaser for H. D. MCCAFFREY, Engineer and Contractor of Telegraph lines, Oswego, N.Y.

**RAILS AND CARS FOR SALE.**

Light Steel Rails for Tramways; good order. Cars for lumber, cheap.

JOHN J. GARTSHORE,

49 Front St. West,

Toronto.

**WANTED.**

**QUEBEC BIRCH**—Those who can furnish choice lumber are invited to correspond with

JOHN S. MAISON & CO.

240 Eleventh Avenue,

New York City.

**Saw and Shingle Mill for Sale.**

**SAW MILL** at Fesserton, on G.T.R Midland division, one mile from Waubashene; capacity 20,000 ft. per day; 50 horse power engine, 55 horse power boiler, 64 inch circulars, double edger, double trimmer, slab saw, etc.; furnace supplied by self-feeder. 24 in planer and matcher attached, all in good running order, only requiring usual spring repairs. Docks, tramways, siding complete. Also on same property **SHINGLE MILL**, capacity 25 M. daily—Swing machine, Quartering Saw, Knotting Saw, all in good running order. Carts, Sleighs, Shanty Supplies, also about 1,200,000 ft. saw logs now on North river or in Mill Pond. Will be sold in one or more lots to suit purchaser. Cheap and on easy terms. Apply to H. MYDDLETON WOOD, 79 Grenville St. Toronto., Administrator of Estate of the late G. W. Brisley.

*Pine Timber Limits*

**FOR SALE**

On Upper Ottawa running back from Birch Lake. Main Ottawa river. 300 miles—selected years ago—well timbered, good streams for driving. Terms of payment easy.

Apply to

J. BELL FORSYTH & CO.

QUEBEC.

**WILLIAM FOSTER**

Lumber & Commission Merchant

Receiver and forwarder of

LUMBER, LATH & SHINGLES

Correspondence Solicited.

OWEN SOUND,

ONT.

**TIMBER \* LANDS FOR SALE**

**5000 Acres of Timber Lands on the Manitoulin Island,**

Patented and unpatented, are offered at the

Low Price of

**\$5.00 PER ACRE.**

Some of the lots have timber on them worth \$20 per acre, and the land is of fair quality for farming when cleared.

The Dominion Government having recently taken off the Export Duty on Telegraph Poles, Railway Ties, Shingle Bolts and Saw Logs, the value of the timber on the Island is doubled, owing to its great facilities for shipment to Detroit, Chicago, Toledo, Buffalo, Cleveland and all Lake ports.

The late owners, Messrs. Wm. and Robert Henry, are both deceased, and there being no one to carry on their business, these lands will be sold low, in Block to close out the estate. Tenders solicited and purchases liberally dealt with. All necessary information can be obtained from the trustee and Solicitors.

Messrs. FRANCIS & WARDROP,

Barristers, &c.,

JAMES MCGEE, Trustee,

Toronto.

Toronto.

**PROTECT YOUR MILLS**

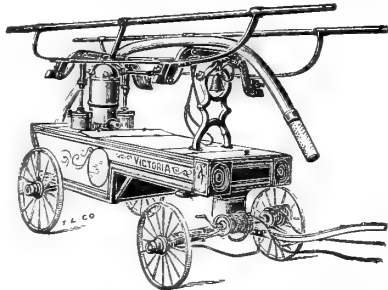

**GIANT HAND FIRE ENGINES.**

From \$200 to \$700

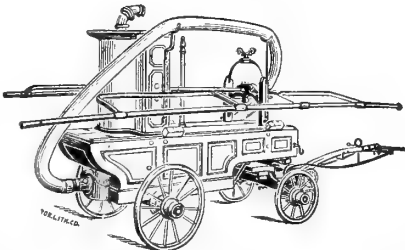

800 Feet Second-Hand 2 in. Fire Hose Cheap.

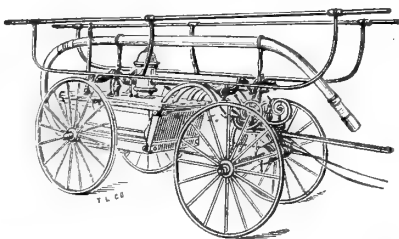

**Waterous Engine Works Co.,**  
Brantford, Canada.



**COWPER & GREGORY.**

**RECEIVERS** and Forwarders of Lumber, Lath, Shingles, &c. Unexcelled facilities for shipping by canal or rail. Tonawanda, N. Y.

**A. M. DODGE & CO.**

**MANUFACTURERS** of and Wholesale dealers in all kinds of Lumber, Lath and Shingles. Tonawanda, N. Y.

**E. & B. HOLMES.**

**WHOLESALE** dealers in Lumber and Timber. Office, Michigan and Canal Streets, Buffalo, N. Y.

**CHEESMAN DODGE**

**TIMBER** and Lumber Merchants. Ship and Boat stock, Railroad Ties, &c. Office, 10 West Seneca Street, Buffalo.

**Buffalo Hardwood Lumber Co.**

**OFFICE** and yard, 175 Louisiana Street, Buffalo. Holders of Hardwood stocks are invited to correspond.

**EMMET FLEMING**

**INSPECTOR** and Commission dealer in Lumber. Office, 251 Louisiana Street, Buffalo, N. Y.

**LAYCOCK LUMBER CO.**

**MANUFACTURERS** of Pine, Hemlock and Oak Timber up to 85 feet in length. Saw Mills: Ackley, Pa., Black Rock, N. Y., Gravenhurst, Ont. Office, corner Main and Seneca Sts, Buffalo, N. Y.

**J. & T. CHARLTON**

**WHOLESALE** dealers in Masts and Spars, Canada Round Pine, &c. Tonawanda, N. Y.

**WILLARD W. BROWN.**

**202** Main Street, Buffalo, handles all kinds of Hard Woods.

**A. P. & W. E. KELLEY CO.**

**WHOLESALE** Lumber dealers. Yards at Tonawanda and Chicago. Correspondence invited.

**C. P. HAZARD.**

**WHOLESALE** dealer in Lumber, Shingles, Lath and Fence Posts. Correspondence invited from the Canadian trade. No 92 River Street, Buffalo, N. Y.

**L. A. KELSEY LUMBER CO., (Ltd.)**

**MANUFACTURERS** and dealers in Hardwood Lumber of all kinds. Describe stock and write for prices. Office Tonawanda, N. Y.

**BOVEE & HOWDEN**

**MANUFACTURERS** and Wholesale dealers in Hard and Soft Wood Lumber. Holders of Canadian stocks are invited to write for quotations. Offices at Tonawanda and Le Roy, N. Y.

**THE TONAWANDA LUMBER CO.**

**MILLS** at East Tawas, Mich.; office 106 Main Street, opposite N. Y. C. and H. R. R. Station, North Tonawanda, N. Y.

**J. J. TURNER,**

**Sail, Tent and Awning Maker.**

251 GEORGE AND 154 KING STREETS, PETERBOROUGH.

Canoe, Yacht and Boat Sails made to order. Perfect Fits guaranteed.

Every description of Lumbermen's Sub sties and Waterproof Clothing.

**Fawcett & Co.**

**MERCHANT \* TAILORS,**

269 Queen St. E., Opp. Seaton St., Toronto.

First-Class Goods and Trimmings. Workmanship and Fit Guaranteed. All Orders Punctually Executed.

HERBERT G. ROSS.

Box 278.

REGINALD C. BLAKER

**N. G. ROSS & CO.**

*Real Estate, Fire and Life Insurance, Shipping and General Commission Agents.*

Timber Limits and Farming Lands a Specialty.

A.B.C. Code, Cable address, "Ross."

**NEW WESTMINSTER. - - B. C.**

CORRESPONDENCE SOLICITED.

**The American Lumber Yard**

**HAMBURG, GERMANY,**

Offers the best facilities for Yarding and Selling all kinds of

**American Wood Goods.**

Address :

ROSENBACHER & CO.,

BANKERS, Hamburg.

CARL GARTNER, Agent,

Hamburg.

**GEORGE McWILLIAMS**

(Successor to Wm. Forsyth.)

MANUFACTURER OF

**TAPER PIKE POLES,**

PEEVEY STOCKS, CANT HOOK AND GAFF HOOK HANDLES.

The only Successful Taper Pike Pole Manufactured.

Peterborough,

Ontario.

TORONTO AGENCY OF

# The Rathbun Co.

Invites correspondence from manufacturers and others having

**OAK, ASH, BIRCH,  
BASSWOOD  
AND  
GOOD PINE LUMBER**

**CEDAR AND PINE  
SHINGLES  
FOR SALE**

Write to

**T. W. WALKER, Agent  
TORONTO**

Office, Cor. Spadina Ave. & Front St.

## Cash for Lumber

**W. N. McEachren & Co.**

Wholesale dealers in all kinds of

## HARDWOOD LUMBER

**NO. 3 DOCK  
TORONTO**

WRITE US FOR PRICES AND SIZES TO CUT.

WE PAY CASH WHEN LOADED ON CARS.



SEALED TENDERS marked "For Mounted Police Clothing Supplies," and addressed to the Honourable the Minister of Railways and Canals, will be received up to noon on Monday, 9th March, 1891.

Printed forms of tender containing full information as to the articles and quantities required, may be had on application to the undersigned.

No tender will be received unless made on such printed forms. Patterns of articles may be seen at the office of the undersigned.

Each tender must be accompanied by an accepted Canadian bank cheque for an amount equal to 10 per cent. of the total value of the articles tendered for, which will be forfeited if the party decline to enter into a contract when called upon to do so, or if he fail to supply the articles contracted for. If the tender be not accepted the cheque will be returned.

No payment will be made to newspapers inserting this advertisement without authority having been first obtained.

FRED. WHITE,  
Comptroller N.W.M. Police.  
Ottawa, Feby. 9th, 1891.



**SCRIBNER'S  
LUMBER  
AND  
LOG BOOK**

Over One Million Sold.

MOST complete book of its kind ever published. Gives measurement of all kinds of Lumber, Logs, Planks, Scantling; cubical contents of square and round Timber; hints to lumber dealers; wood measure; speed of circular saws; care of saws; cord-wood tables; felling trees; growth of trees; land measure; wages, rent, board, interest, stave and heading bolts, etc. Standard book throughout the United States and Canada. Get the new illustrated edition of 1892. Ask your book-seller for it. Send post-paid for 35 cents.

A. G. MORTIMER, Toronto, Ont.

# Do You Stop Your Saw

by lifting a tightner, throwing off the heavy belt, or stopping the engine; All these methods are objectionable.

We have patented a Friction Grip Pulley. Compact, Simple, Durable, Large Frictional Area, Ample clearance when out of engagement, Powerful gripping mechanism.

We guarantee this Pulley to work satisfactorily, and to be thoroughly reliable.

Made Split when required. And with 2, 3, 4 and 6 grips for any class of work. Also a Cut-off Coupling of the same design.

SEND FOR CIRCULARS AND PRICES

## The Waterous Engine Works Co., Brantford, Canada

**NAPANEE CEMENT COMPANY  
(LIMITED.)**

— MANUFACTURERS OF —

### Hydraulic Cement

PARTICULARLY adapted for Dams, Smoke Stacks, Foundations, Culverts, Cisterns, Cellars, etc.

ENDORSED BY LEADING RAILWAYS AND CONTRACTORS.

**ROACH \* LIME,**

For Building, Plastering, Gas Purifying, Paper Making, &c.

## THE RATHBUN COMP'Y, DESERONTO, ONT.,

MANUFACTURERS OF

### \*TERRA COTTA\* FIRE-PROOFING \*

For Use in Old and New Buildings.

Endorsed by Leading Architects. Absolutely Fire-proof. About as Cheap as Wood or Brick. Weight One-Third that of Brick. Does not Crack on application of Heat or Water. Deadens Noise. Gives Warmth in Winter; Coolness in Summer.

## Galt \* Machine \* Knife \* Works.



**MACHINE KNIVES**

OF EVERY DESCRIPTION FOR

**Planing, Moulding & Stave Cutting.**

SEND FOR PRICE LIST

**PETER HAY, - - - GALT, ONT.**

## MILL MACHINERY

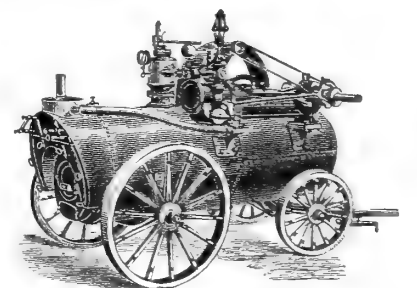
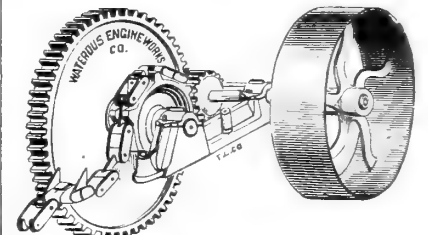
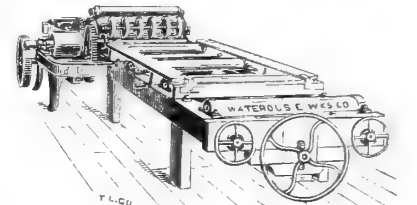
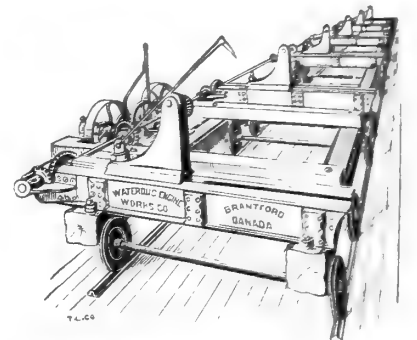
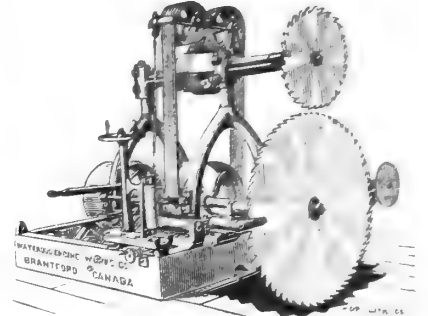
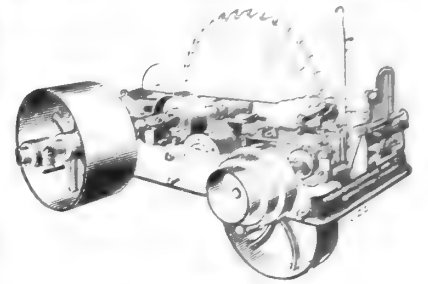

### Link Belting

Sawdust and Refuse Carriers. Line Rolls.



Transfers. Lumber Sorters. Trimmers. Slashers, Etc.

All products into, through, and out of mill.

Send for Catalogue and Prices.

**Waterous Engine Works Co.,  
Brantford, Canada.**

# Friction Pulley Board.

The Best Materials ever used  
for Frictions of all  
\* kinds \*

MANUFACTURED BY

Asbestos  
Mill  
Board.

The **DOMINION LEATHER BOARD COMPANY,**  
Montreal, Quebec.

Steam  
Packing.

SAMPLES FURNISHED.

PLEASE MENTION THIS PAPER.

CORRESPONDENCE SOLICITED.

TO MILL OWNERS, MANUFACTURERS  
AND ALL WHO ARE USING

## Stop the Engine Instantly

*Leather\*Belting*

IF YOU WANT BELTING

Which will Run Straight on the Pulleys,  
Which is Thoroughly Well Stretched,  
Which will not Tear at the Lace Holes,  
Which will give Complete Satisfaction,

— SEND TO —

**F. E. DIXON & CO.**

MANUFACTURERS OF

PATENT LAP-JOINT STAR RIVET

\*LEATHER\*BELTING\*

70 King Street East, Toronto.

Sole Agents in Canada for the

**CELEBRATED PHOENIX OIL**

The Only Perfect Belt Dressing.

All our Belting is sold at the Canadian price list. Please compare before purchasing. Send for Discounts and our Pamphlet on Belting.

Unfortunately that is impossible, it is several stories below, therefore to stop this countershaft is a work of minutes.

The Accident

The stopping of the engine would have prevented or mitigated it; not an unusual one. Often it results in the loss of valuable life.

This Line Shaft

Could have been instantly disconnected from the power in any part of the room had it been driven with a Friction Grip Pulley.

## Will it not pay you

To investigate the merits of the newest and best Grip Pulley and Cut-off Coupling, "THE WATEROUS;" It is safe, economical in belts and time.

**WATEROUS ENGINE WORKS CO., Ltd., Brantford, Canada.**

## B. F. Sturtevant's Patent Progressive Lumber Dry Kiln.

RELIABLE RAPID! CHEAP!

GUARANTEED  
TO DRY

—IN—

Best Manner Possible

ALL KINDS OF  
HARD and SOFT  
WOOD LUMBER.

WRITE\*FOR\*CATALOGUE.

91 LIBERTY STREET  
NEW YORK.

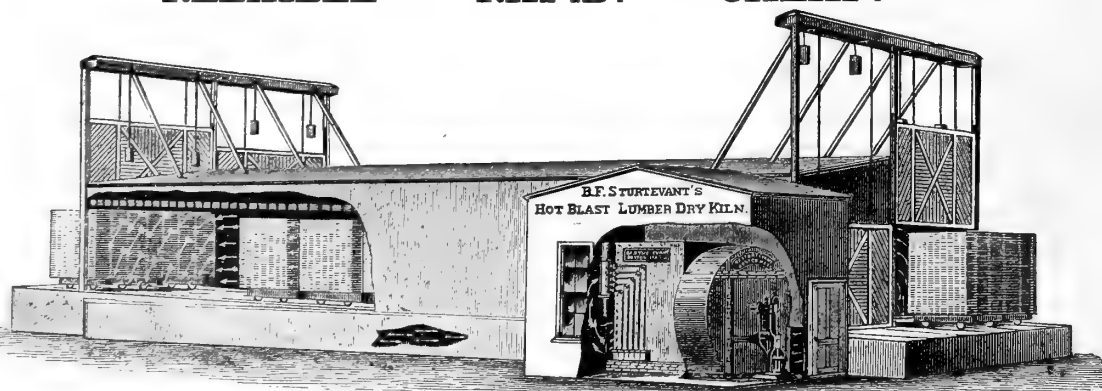

NO WARPING  
CHECKING  
AND BLUEING

—WITH THE—

**STURTEVANT**

Patent Hot Blast

Steam Heating

Apparatus.

31 N. CANAL STREET  
CHICAGO.

B. F. STURTEVANT, Patentee and Sole Manufacturer, 34 Oliver Street, (corner of Franklin street) BOSTON, MASS., U. S. A.  
A. R. Williams, Soho Machine Works, Toronto, General Agent for the Dominion.



# The Only Successful Kiln for Drying Oak and other Hardwoods

**"THE ANDREWS"**

NEW LUMBER

## DRY-KILN

Its remarkable efficiency depends upon its peculiar mode of applying heat to, and eliminating moisture from, the air used in drying. We use no costly fan, engine or other device that requires constant attention, nor do we waste heat by a special chimney. The air circulates through the lumber, and the moisture absorbed from it is extracted from the air by natural methods. You can not afford to be without it.

Our Process Duplicates Nature.



Outside View of the Andrews Kiln.

The following well-known furniture manufacturers have recently purchased the "ANDREWS KILN"

- Estey Manufacturing Co., - - - Owasa, Mich.
- East Shore Furniture Co., - - - Manistee, Mich.
- Universal Tripod Co., - - - Grand Rapids, Mich.
- Grand Rapids School Furniture Co., Grand Rapids, Mich.
- New England Furniture Co., - Grand Rapids, Mich.
- Milwaukee Chair Co., - - - Milwaukee, Wis.
- Oshkosh Furniture Co., - - - Oshkosh, Wis.
- Skandia Furniture Co., - - - Pockfork, Ill.
- Story & Clark Organ Co., - - - Chicago, Ill.
- Rock Falls Manufacturing Co., - - - Sterling, Ill.
- Courey & Birely Table Co., - - - Shelbyville, Ind.
- Southern Spring Bed Co., - - - Atlanta, Ga.
- Sidney School Furniture Co., - - - Sidney, Ohio.
- New Richmond Church Furniture Co., N. Richmond, O.

## A. N. Andrews & Co., Proprietors and Manufacturers

215, 217, 219, 221 Wabash Ave., CHICAGO, ILL.

## The Casselman Lumber Co.

CASSELMAN, ONT. Successors to FLATT & BRADLEY.

ESPECIAL GOOD FACILITIES FOR SHIPPING.

HEMLOCK BILL STUFF OF EXCELLENT QUALITY.

ALSO MANUFACTURERS OF

PINE, SPRUCE, ASH, MAPLE AND OTHER HARDWOODS.

CORRESPONDENCE SOLICITED.

J. W. MAITLAND  
H. RIXON

J. G. AINSLIE  
W. STODART

## Maitland, Rixon & Co.,

Owen Sound, Ont.

## Saw Millers AND Lumber Dealers

All kinds of Building Material kept in stock.

WE MAKE A SPECIALTY OF

LONG BILL STUFF IN ROCK ELM, PINE, CEDAR AND HEMLOCK,  
QUOTATIONS FURNISHED ON APPLICATION.

## F. J. DRAKE,

PATENTEE AND MANUFACTURER OF

## SAW, SHINGLE AND LATH MACHINERY

Belleville, Ontario.

### DRAKE'S PATENT DAUNTLESS SHINGLE AND HEADING MACHINE

Capacity from 25,000 to 50,000 per day.

The frame of iron throughout, very heavy and rigid, strongly bolted and braced; carriage very light and strong, made of forged cast steel saw plate, running on steel ways or tracks; will take in a block 18 inches wide and 19 inches long, adjustable for 16 inch or 18 inch shingles.

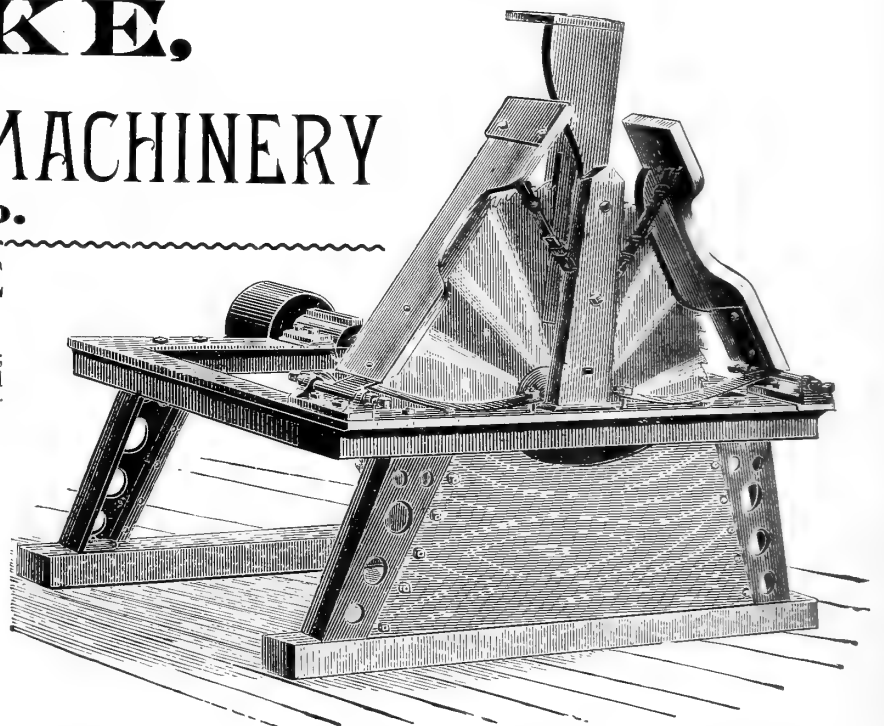
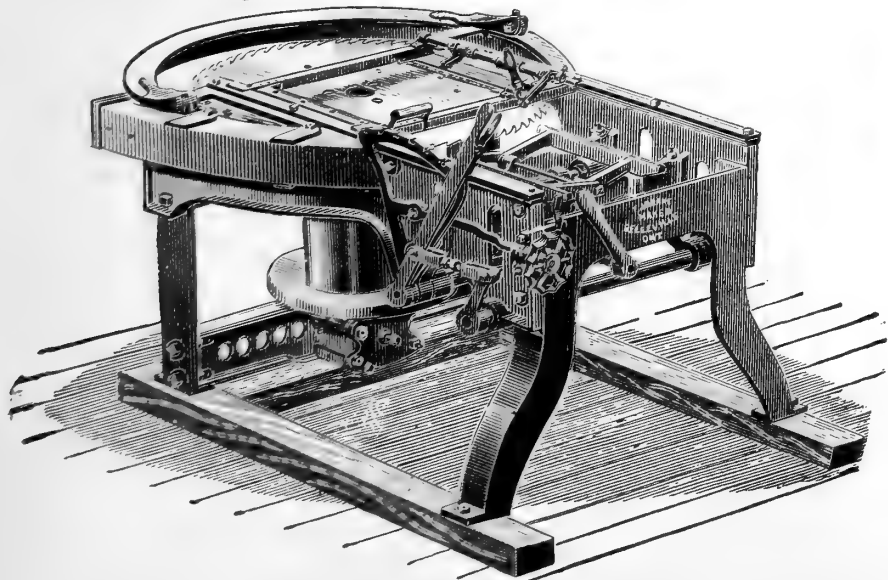

## Drake's Improved Shingle Edger.

With 40 inch saw will make more No. 1 Shingles from the same quantity of timber than any Wheel Jointer in existence.

It has a heavy iron frame made for two operators, two inch steel saw arbor, with extra long bearings; driving pulley 8 inches diameter, 7 inch face, saw 40 inches diameter, 16 gauge, speed, 1,600 per minute.

Mill men who have once used this machine will not use any other. For capacity, removing sap-knots, rot or any other imperfections, for making parallel shingles and economy of stock, it is superior to any other.

Also manufacturer of other kinds of Shingle Jointers, both self-acting and hand-feed Shingle Machines, Packing Boxes, Drag Saw Machines, Bolters, Stationary and Portable Saw Mills, Double Edgers, Single Edgers, Slab Saw Rigs, Bull Wheel Rigs, Lath Machines, Lath Bolters, in fact a general line of Mill Machinery, with Pulleys, Shafting, &c. Satisfaction guaranteed in all cases. Send for estimates on anything required, and the same will receive immediate attention.

GEO. HASTINGS.

JOHN GRAY.

H. HANCOCK.

# GEO. HASTINGS & CO.

**Lumber Merchants**

TRUST BUILDING CHAMBERS,  
Cor. Yonge and Colborne Streets.

TORONTO.

All Kinds of Pine and Hardwood Lumber.

BILL STUFF CUT TO ORDER A SPECIALTY.

# TORONTO HARDWOOD LUMBER CO.

Wholesale Dealers and Shippers in all kinds of

## HARDWOOD \* LUMBER

83 Front Street West, Corner Lorne Street, - TORONTO.

OFFICES  
Hamilton, Toronto  
Windsor

TELEPHONE  
No. 1046

MILLS  
Gravenhurst, Huntsville  
Katrine.

# ROBERT THOMSON & CO.

DEALERS IN

**Pine and Hardwood**

## LUMBER \* TIMBER

Mills Operating all the year round. Correspondence Solicited.

TORONTO OFFICE  
LONDON CANADIAN CHAMBERS 103 BAY STREET,

THOMAS MEANEY,  
REPRESENTATIVE.

**TORONTO.**

# DONOGH & OLIVER,

Wholesale Dealers in

# LUMBER

OFFICE:

Nos. 16 and 17 Imperial Bank Buildings,  
WELLINGTON STREET EAST.

**TORONTO, ONT.**

DALTON McCARTHY,  
President.

A. ECKARDT,  
Secretary

JOHN MCGREGOR,  
Manager.

# Toronto and Midland Mfg Co.

(INCORPORATED.)

## Wholesale \* Lumber \* Dealers

AND MANUFACTURERS OF

## DRESSED LUMBER, FLOORING

Ceiling, Sheeting, Siding, Shelving, Mouldings of all Descriptions.

Office and Yard:

FOOT OF SPADINA AVE., - TORONTO.

Planing Mills: MIDLAND, ONT.

# PORTER, ROBERTSON & CO.

STOCKS  
STRIPS  
SIDINGS  
BILLSTUFF

WHOLESALE

## LUMBER

DEALERS

HARDWOODS  
HEMLOCK  
SHINGLES  
LATH, ETC.

Millichamp's Buildings,

35 \* Adelaide \* Street \* East,  
TORONTO.

YARD: NORTHERN DOCK, FOOT OF BATHURST STREET.

# ROBIN & SADLER

MANUFACTURERS OF

## Leather Belting

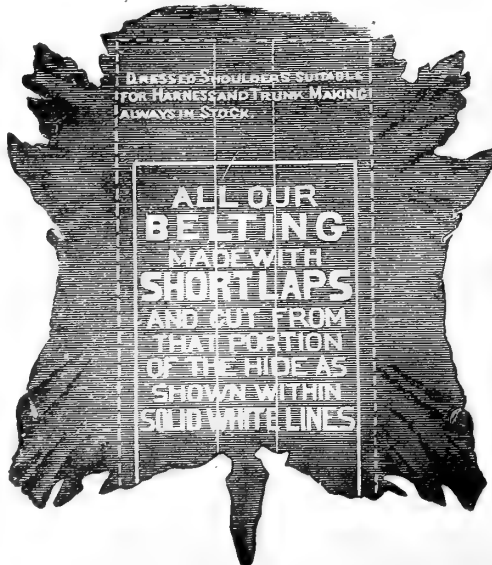

DEALERS IN

## Lace Leather Cotton and Gandy Belting

2518, 2520 and 2522 Notre Dame St.

MONTREAL.

129 Bay Street, TORONTO.

The Gold Medal,  
Toronto, 1883

# WOOD WORKING MACHINERY

The Gold Medal,  
London, 1883

## For Door, Sash, Blind and Furniture Factories

PLANERS.

MOULDERS.

TENONERS.

SHAPERS.

RIP SAWS.

SAND PAPERERS.

BAND SAWS.

BAND RE-SAWS.

PANEL RAISERS.

DOVETAILERS.

JOINTERS.

DOUBLE SPINDLE BORER.

BUZZ PLANERS.

MORTICERS.

BLIND MACHINERY.

BAND SAW FILER.

BAND SAW SETTER.

ETC., ETC.

# The Galt Bros. Co., Limited, GALT, ONTARIO.

Write for Circulars  
and Prices.

Correspondence  
Solicited.

## Rhodes' Improved Swage for Circular and Gang Saws.

≡ PATENTED JULY 2, 1889 ≡

THE MOST PERFECT MACHINE FOR THE PURPOSE EVER INTRODUCED.

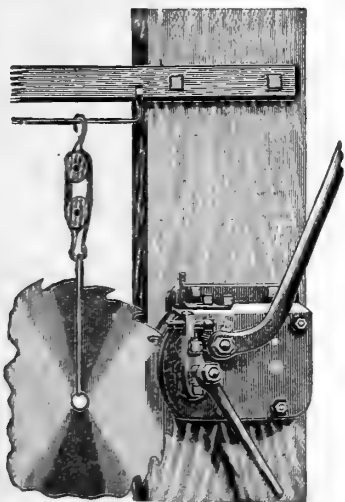

SWAGE IN OPERATION.

It will swage the hardest as well as the softest saws. Never pulls the points of the teeth off, as the swaging is done by direct and steady pressure, and not by rolling pressure.

Swaging done with this machine will stand longer than when swaged with any other machine or by hand.

It makes the swage the heaviest on the under side of the tooth, and leaves the face of the tooth perfectly straight.

It does not shorten the tooth as done by upsetting. It has a positive clamp so a saw cannot slip while being swaged, therefore every tooth is an exact duplicate of the other.

Corners never drop off if swaged with this machine, as it does not injure the steel, therefore the teeth can all be kept of a length.

It is very simply constructed: nothing to break or wear out. Easily adjusted. Any ordinary man can swage a circular saw in from 10 to 12 minutes. Is thoroughly constructed of the best material, all the parts requiring it are made of steel of the best quality. Every swage is thoroughly tested before leaving the shop.

We positively guarantee the swage to do all we claim for it in this circular.

Full and complete instructions for adjusting and operating accompany the swage.

SEND FOR PRICE LIST OF

RHODES' IMPROVED

Automatic Band Saw Swages, Circular Saw Swages, Gang Saw Swages, Shingle Saw Swages.

—MANUFACTURED EXCLUSIVELY BY—

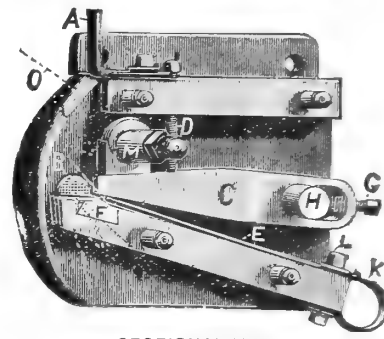

SECTIONAL VIEW.

P. O. BOX 430.

## Palmiter, Empey & Co., Galt, Ont.

Established 1849.

Incorporated 1884.



We use nothing but W. J. & Sons' English Steel in our saws and the name speaks for itself.

# Detroit Saw Works

MANUFACTURERS OF

## Circular, Gang, Mulay, Drag and Cross-Cut Saws.

MOLDING AND PLANING KNIVES,

*French Band Saws, Emery Wheels and General Mill Supplies.*

### 66, 68, 70 and 72 Fort St. East, DETROIT, MICH.

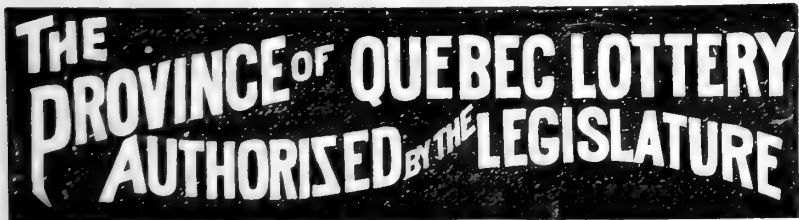

MONTHLY DRAWINGS ON

## 2nd Wednesday of Every Month

S. E. LEFEBVRE, Manager.

Head Office—81 ST. JAMES STREET, - MONTREAL.

PATENTED 5TH MARCH, 1877.

## PARKER & EVANS.

Sole Proprietors of the

FAMOUS INTERNATIONAL

## BOILER - FLUID - COMPOUND.

This compound will save its cost many times in one year by saving fuel.

It eradicates scale, and when the Boiler is once Clean a very small quantity keeps it clean and free from all incrustation. One fourth the dose will prevent a new Boiler from scaling so long as it is used regularly.

Contains no Caustic Soda, and is the only matter yet known that will not injure metals in any way, and emits a clear pure steam.

30 WILLIAM STREET, - MONTREAL.



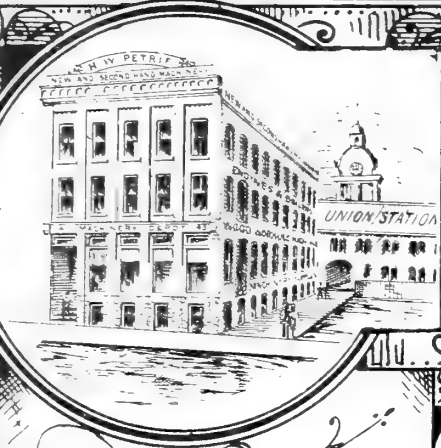

# PETRIE'S MACHINERY DEPOT.

*Special Bargains  
This Month.*

*Send for our Illustrated Catalogue  
New and Second Hand  
Machinery.*

- 225 H. P. PAIR OF ENGINES—Worthy & Co., builders.
  - 75 H. P. HORIZONTAL ENGINE—Gartshore build.
  - 50 H. P. HORIZONTAL ENGINE—Goldie & McCulloch builders.
  - 50 H. P. HORIZONTAL ENGINE—Inglis & Hunter builders.
  - 50 H. P. HORIZONTAL ENGINE—Whitelaw builder.
  - 45 H. P. HORIZONTAL ENGINE—Beckett builder.
  - 45 H. P. HORIZONTAL ENGINE—Runciman & Co. builders.
  - 40 H. P. HORIZONTAL ENGINE—Waterous Engine Co. builders.
  - 85 H. P. HORIZONTAL ENGINE—Beck, of Baden, builder.
  - 35 H. P. HORIZONTAL ENGINE—Northey make.
  - 30 H. P. HORIZONTAL ENGINE—Northey & Co. builders.
  - 25 H. P. HORIZONTAL ENGINE—American make.
  - 25 H. P. HORIZONTAL ENGINE—Waterous Engine Co. build.
  - 20 H. P. PAIR OF TWIN ENGINES—Montreal build.
  - 20 H. P. HORIZONTAL ENGINE—Corbett & Sons builders.
  - 20 H. P. HORIZONTAL ENGINE—F. G. Beckett & Co. build.
  - 20 H. P. ROARY STEAM ENGINE—Erie Iron Works make.
  - 20 H. P. NEW HORIZONTAL ENGINES—Peterson build.
  - 20 H. P. HORIZONTAL ENGINE—Killey builder.
  - 18 H. P. HORIZONTAL ENGINE—Geo. White builder.
  - 16 H. P. HORIZONTAL ENGINE—American make.
  - 16 H. P. HORIZONTAL ENGINE—Waterous Engine Co. builders.
  - 16 H. P. HORIZONTAL ENGINE—Beckett build.
  - 16 H. P. HORIZONTAL ENGINE—Tift & Sons builders.
  - 15 H. P. HORIZONTAL ENGINE—F. G. Beckett builder.
  - 12 H. P. HORIZONTAL ENGINE—In good order.
  - 12 H. P. HORIZONTAL ENGINE—American make.
  - 10 H. P. HORIZONTAL ENGINE—F. G. Beckett builder.
  - 10 H. P. VERTICAL ENGINE—Swamscott & Co. make.
  - 8 H. P. VERTICAL ENGINE—Good order.
- FULL PARTICULARS regarding any of above engines on application; I also have a large stock of portable and semi-portable engines and boilers.

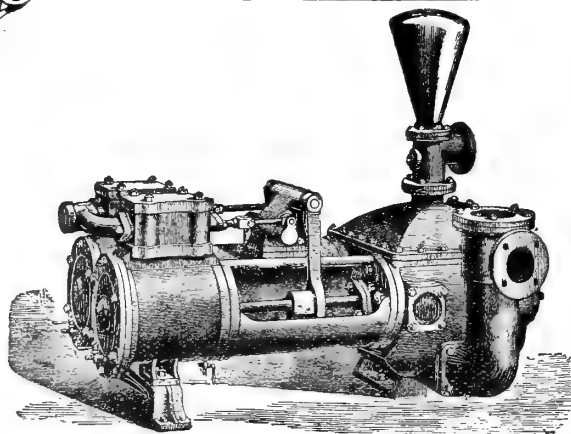

STEAM PUMPS

- All Sizes and Makes. -

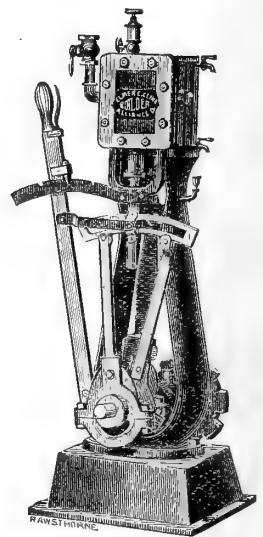

MARINE ENGINES

All kinds.

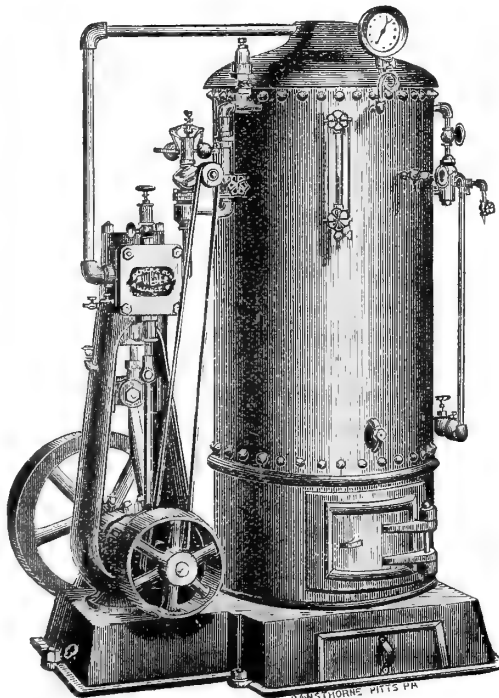

BOILERS AND ENGINES

Suitable for all classes of Business.

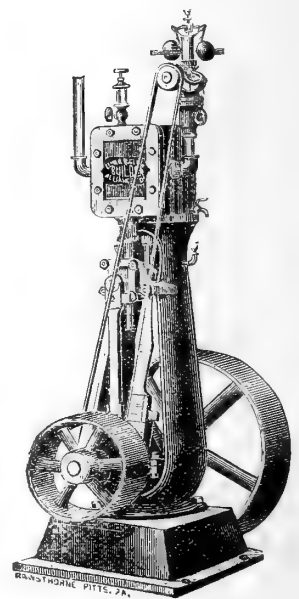

VERTICAL

ENGINES.

**H. W. PETRIE** PROPRIETOR. 141 TO 145 FRONT ST. WEST. **TORONTO, ONT.**

C. C. CLEVELAND. G. F. CLEVELAND.  
**J. L. GOODHUE & CO.,**  
 MANUFACTURERS OF  
**Leather Belting**  
 AND  
**Lace Leather.**  
 DANVILLE - - QUEBEC.

**One of the Greatest Chances in America**  
 For a Lumber yard or a Profitable Wholesale Wood-working Industry. One of the best located plants in Tonawanda may be leased, covering seven hundred feet docked water front on the Harbor; with ground five hundred feet in depth; large factory building; two hundred by one hundred and twenty-five, with basement; brick boiler and fuel room detached; suitable for sash, doors, blinds, boxes, and custom planing combined. Tonawanda although carrying three hundred millions of lumber in stock has yet no large industry such as proposed. Will sell or lease for a term of years. Moderate rent, cheap labor, low taxes, lowest insurance.  
**SMITH, FASSETT & CO., Tonawanda, N. Y.**

RAILROAD, BANK & OFFICE  
**DESKS**  
**TEES & CO.,**  
 300 ST. JAMES STREET, MONTREAL.

**STORAGE OF LUMBER.**  
 We are prepared to receive any quantity of Lumber for storage. Freight and money will be advanced on same. Also, Warehouse Receipts issued, which can be hypothecated to banks and others. Storage charges easy. For further particulars apply to  
**W. LEAK & CO.**  
 Lumber, Coal and Wood.  
**DUNDAS STREET, - - TORONTO.**

**GOODDAY, BENSON & CO.**  
 QUEBEC, P. Q.  
**General Lumber AND Timber Merchants.**  
 Correspondence is solicited from parties having choice stocks of Hardwood and Pine to offer, either in the log or in sawn lumber.

**JOHN BERTRAM & SONS,**  
 CANADA TOOL WORKS  
 DUNDAS, ONTARIO.  
 MANUFACTURERS OF  
**WOOD-WORKING MACHINERY**  
 MACHINE TOOLS, ETC.  
 Write for Prices and Catalogues

**Packing Cases in Shooks.**  
 Any Saw mill in Canada able to undertake large orders for Case Boards is requested to communicate with  
**W. & C. PANTIN**  
 147 Upper Thames Street,  
**LONDON, - - - - - ENC.**

**GEO. CORMACK**  
 Wholesale and Retail Dealer in  
*All kinds of LUMBER.*  
 Lumber Shipped to all parts by Rail or Vessel.  
**WHITBY, - - - - - ONTARIO**

William Hamilton, Water Works Department, Pumping House,  
 Superintendent,  
 ALONZO W. SPOONER, Port Hope.  
 Toronto, Jan. 6th, 1891

Dear Sir,—I am pleased to say that after nearly three years constant use, day and night, on our largest engine your COPPERINE has stood its work well. I have not had to renew any of the heavy bearings yet, so I consider that speaks for itself. I am pleased to recommend it to any one in need of metal to stand heavy work.

I remain, yours truly,  
**J. C. FERGUSON, Chief Engineer,**  
 Toronto Water Works.

**A. T. ANDERSON & CO.,**  
 CONTRACTORS FOR  
**ELECTRICAL AND GENERAL MACHINERY.**  
 Complete instalations of steam and Hydraulic Power, Electric Light and Power Plants, Wiring and Construction for Arc and Incandescent Lighting. Agents for the celebrated "C. & C." Electric Motors.  
 75 Adelaide Street East,  
 Toronto, Ont., Canada.  
 Estimates furnished and every information cheerfully given to intending purchasers.  
 N. B.—Only first-class work on which a full guarantee will be given.

**THE RATHBUN COMPANY,**  
 DESERONTO, - - ONTARIO,  
 MANUFACTURERS OF  
**Doors, Sash, Blinds, Stairs**  
 AND ALL KINDS OF WOODEN HOUSE FINISHING MATERIALS.  
**CEDAR OIL FOR PURGING BOILERS.**  
 CORRESPONDENCE SOLICITED

**The American Lumber Yard**  
**HAMBURG, GERMANY,**  
 Offers the best facilities for Yarding and Selling all kinds of  
**American Wood Goods.**  
 Address :  
**ROSENBACHER & CO.,** **CARL GARTNER, Agent,**  
 BANKERS, Hamburg. **Hamburg.**

**ROBIN & SADLER**  
 MANUFACTURERS OF  
**Leather Belting**  
 DEALERS IN  
**Lace Leather**  
 Cotton and  
**Gandy Belting**  
 2518, 2520 and 2522 Notre Dame St.  
**MONTREAL.**  
 129 Bay Street, **TORONTO,**



TAPER TOOTH.



TELEPHONE 5120.

**Burns & Thomas**

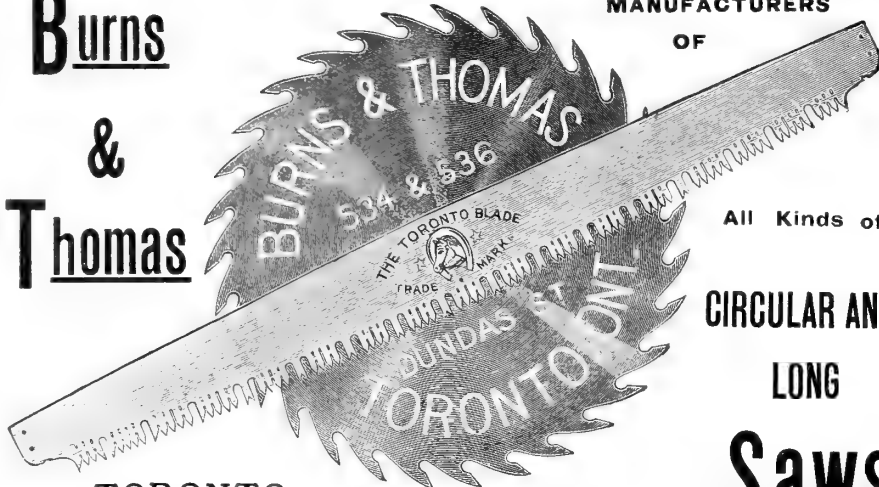

TORONTO.

MANUFACTURERS OF

LANCE TOOTH.

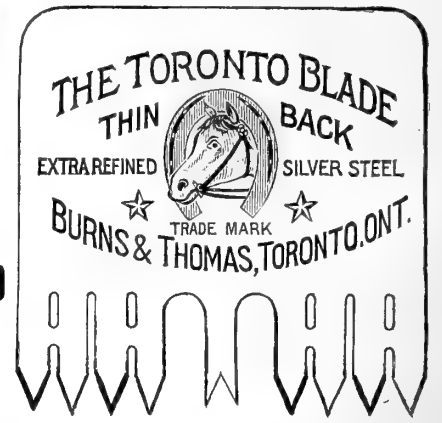

WORKS AT PARKDALE.

All Kinds of  
CIRCULAR AND  
LONG  
**Saws**

TO MILL OWNERS, MANUFACTURERS

AND ALL WHO ARE USING

# Leather \* Belting

IF YOU WANT BELTING

Which will Run Straight on the Pulleys,  
Which is Thoroughly Well Stretched,  
Which will not Tear at the Lace Holes,  
Which will give Complete Satisfaction,

— SEND TO —

## F. E. DIXON & Co.

MANUFACTURERS OF

PATENT LAP-JOINT STAR RIVET

### \* LEATHER \* BELTING \*

70 King Street East, Toronto.

Sole Agents in Canada for the

## CELEBRATED PHOENIX OIL

The Only Perfect Belt Dressing.

All our Belting is sold at the Canadian price list. Please compare before purchasing. Send for Discounts and our Pamphlet on Belting.

TORONTO AGENCY OF

## The Rathbun Co.

ARE OPEN TO PURCHASE

OAK, ASH, BIRCH,  
BASSWOOD

AND

GOOD PINE LUMBER

CEDAR AND PINE  
SHINGLES

Manufacturers having such for sale are invited to communicate with

T. W. WALKER, Agent

TORONTO

Office, Cor. Spadina Ave. & Front St.



### SCRIBNER'S LUMBER AND LOG BOOK

Over One Million Sold.

MOST complete book of its kind ever published. Gives measurement of all kinds of Lumber, Logs, Planks, Scantling; cubical contents of square and round Timber; hints to lumber dealers; wood measure; speed of circular saws; care of saws; cord-wood tables; felling trees; growth of trees; land measure; wages, rent, board, interest, stave and heading bolts, etc. Standard book throughout the United States and Canada. Get the new illustrated edition of 1882. Ask your book-seller for it. Send post-paid for 35 cents.

GEO. W. FISHER,

Box 238, Rochester, N. Y.

or A. G. MORTIMER,

Toronto, Ontario.

## WICKES BROS., Saginaw, Mich.

MANUFACTURERS OF

### GANGS, ENGINES AND BOILERS.

The accompanying cut represents our new No. 3 Complete Iron Frame Gang Mill especially designed to meet the demand for a smaller type of mill. The strongest and most durable for high speed and thin saws. Write for further particulars.

Southern Agents,  
McARDLE &  
SINCLAIR,  
50 & 52 Barronne St  
New Orleans, La.

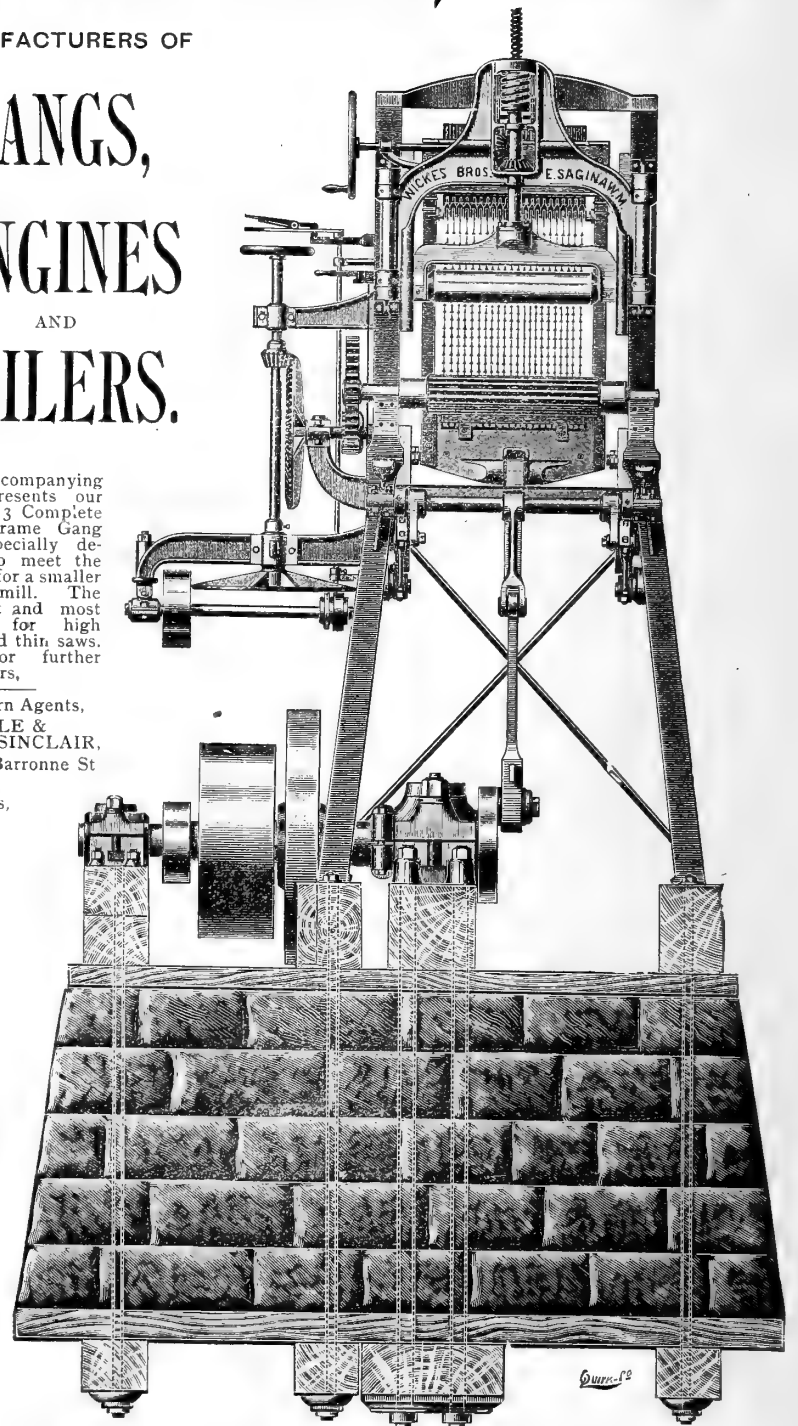

## Fawcett & Co.

### MERCHANT \* TAILORS,

269 Queen St. E., Opp. Seaton St., Toronto.

First-Class Goods and Trimmings.

Workmanship and Fit Guaranteed.

All Orders Punctually Executed.



# THE CANADA LUMBERMAN.

VOLUME XII }  
NUMBER 4. }

TORONTO, ONT., APRIL, 1891.

TERMS, \$1.00 PER YEAR  
SINGLE COPIES, 10 CENTS

## CONTINENTAL WOODS.

THE shantyman as he felled beautiful specimens of forest pine growth this season, lopped off the limbs and cut the trees into logs; the teamster as he hauled them to the skids or the dump; the raftsmen as he accompanies the season's cut down stream; or the mill hands who manipulate the deals, all or nearly all, if questioned in their leisure moments about the article that supplies them indirectly with their daily bread and butter, would be able to give meagre information concerning it. Now and then a warehouseman or shipper comes across a box or a cask made of wood differing in appearance from the ordinary packages he is accustomed to handle, and occasionally he is unable to account for its peculiar behavior, when it resists his attempts to fill it full of nails, owing to its tendency to split the wood. He, like his fellow countryman, the shantymen or the raftsmen, might be able to state "it's pine" or "spruce" or a "kind of pine," but he would, as a rule, know little, if anything, about its growth, the elements in the soil necessary for its life, its perpetuation, its weight or specific gravity, its value as a commercial wood or its natural home, that is, the localities where it naturally grows. It is not within the province of this article to discuss the reasons why pine is found in North America from Hudson's Bay to the Gulf of Mexico, and from Newfoundland to California; neither is it intended to explain why the pine family exhibits such marked differences and at the same time such close resemblances. The object is to briefly tell where each variety can be found; to show some of the differences; and to give other scanty items of information. Our Canadian pine under tests of strain bearing, stands fourth. Like the testing of slabs of concrete, marble, sandstone or granite, specimens of a certain length and uniform thickness are placed upon supports and pressure applied midway between them. So that the weight of each would not interfere in measuring the deflection the specimens are placed horizontally and the pressure exerted latitudinally. Canadian, or eastern pine, under such operation is outclassed by the Douglas fir, the long-leafed pine and the short-leafed pine in strength in pounds, but it is first in deflection or bending qualities. Of the pine family proper it is the lightest, and only two woods of its class fall below it—the white spruce and red cedar of the Pacific slopes. Any one at all versed in geography of America can follow the districts, localities, provinces or states where the varieties of pine flourish or flourished; but if the same individual attempted to explain why certain woods had to change their names and identity before becoming of any value commercially, as for instance bundles of white cedar shingles from Michigan selling in Tennessee under the name of cypress, he would have to be an expert in forestry.

### WHITE PINE.

Canadian pine, white pine, or eastern pine, a light, soft, close straight grained, easily worked, but not a strong wood, is found in Newfoundland, the St. Lawrence river basin and great lake region; stretches westward along the southern end of Lake Michigan and trends north-westerly to the valley of Winnipeg. On the eastern coast it follows the Alleghany mountains to Georgia. It must not be confounded with the white pine or cedar pine, or spruce pine, as it is sometimes called, found from South Carolina to Florida and westward on the Gulf of Mexico States to Louisiana. The latter is coarse grained, not durable and brittle, contains more ash and weighs more per cubic foot.

### YELLOW PINE.

Yellow pine has a short leaf, is very heavy, hard, strong, coarse grained, compact, and full of resin, so

much so that it clogs in sawing. It is found on Staten Island and southward to Florida, and through the western part of that state; westward through the Gulf of Mexico states, Tennessee, Eastern Texas, Arkansas, Indian Territory, parts of Kansas and southern Missouri. It is a disputed point as to the value of this wood commercially. It is claimed by long-leafed pine handlers that it is inferior to their stock and on the other hand the producers of it claim it as good if not better.

### LONG-LEAFED PINE.

The long-leafed pine, pitch pine, yellow pine, or as it is better known, Georgia pine, produces the commercial turpentine, pitch and resin. It is found in abundance from S. E. Virginia to central eastern Florida, and through the Gulf of Mexico states to the Red River of the south in Louisiana. It is the heaviest of all pine woods, weighing  $43\frac{1}{2}$  lbs. per cubic foot, where Canadian pine weighs 24 lbs. It is very hard and strong, tough, coarse grained, durable and highly resinous.

Besides the above specimens there are two distinct varieties found in the United States, unknown in Canada—the bull pine of California and the yellow pine of Arizona. Both differ materially from each other, and though in some respects they resemble white pine yet the deviations from it are very marked when the two are compared.

The king of the forest in commercial woods is the Douglas fir, wrongly named for it belongs to the spruce family. Known as Puget Sound, Oregon or British Columbia pine, it is found on the Pacific coast ranges in such abundance that almost every other wood is excluded. It is tenacious, strong, hard, compact, durable and varies in color from light red to yellow. Lumbermen divided it into two varieties, red fir and yellow fir, the former being considered inferior to the yellow fir, on account of its coarse grained nature. The wood contains less ash than in any other pine, spruce or cedar, and in all tests of pressure, compression, transverse strain or other requirements of strength, the Douglas fir heads the list. As might be expected, other varieties of the same *genera* are found in the locality, the only one in great abundance being white spruce. The trees climb skyward 100 to 140 feet, and measure at the base  $2\frac{1}{2}$  to 4 feet in diameter. It is not unlike its sister, white spruce found in Newfoundland, Eastern Canada, Michigan and Minnesota, Maine and Vermont. The latter in commerce is classed with black spruce found in the same latitude and follows the southern course of the Alleghany as far as Florida. All three are light weights, close, straight grained and compact. The white spruce of the Pacific weighs  $21\frac{1}{2}$  lbs. per cubic foot; the white of the Atlantic  $25\frac{1}{4}$  lbs. and the black spruce  $28\frac{1}{2}$  lbs.

## ANECDOTES OF SHANTY LIFE.

BY BARNEY.

IT frequently happens that the taking out of timber becomes necessary in the summer in some localities when the soil and other conditions do not require snow and ice. On one occasion when finishing a tie contract in the early heated term, when black flies and mosquitoes reign in the woods, a gang of shantymen, tired of horse play, were seated around a smudge fire smoking on Sunday afternoon. Some one hinted that a bottle of whiskey would not go badly, and suggested that lots be drawn and the unlucky one foot some nine miles for a supply. The usual squabble occurred as to the manner of drawing, when finally a big, dark com-

plexioned Frenchman bet a gallon and the carrying of it, that he could lie on his face, stark naked, for half an hour and never twitch a muscle from bites of flies or mosquitoes. He was taken up, then undressed himself, and on "time," got into shape. He stood the punishment without a flinch, although covered with the insects. When the challenger, after 27 minutes had expired, saw he was elected, he quietly with a chip picked up a coal and deposited it on the victim's back. It sizzled for a second; then with a spring like a salmon and an oath Mr. Frenchman jumped to his feet, dug his fingers into his back, yelled and danced. When told out of pure mischief that he had lost the bet, he roared: "Sacre! nugh! you bet! you dink ha mans ha geese? shes not bargain for ha wassup."

I was rafting square timber down the St. Lawrence one summer, and arrived at Lachine too late in the day to run the rapids. I ordered the raft to be moored or snubbed on the river side until daylight, and strolled along the main street of the village. Crossing the original canal at the first lock gate I sat down on a log near the swing bridge to watch the river and lake craft lock through. To my right sat a Frenchman, a perfect stranger, who evidently was anxious to form my acquaintance. He kept pointing out the various objects that attracted his attention to me and offered me his tobacco. Finally he said, "You know Yoseph Latour." I replied in the negative. "Not know Yoseph de raffsman; dat's he's raffs over der by de wood skow. He's wife shes keep a la Bon Se Cour in Moreal. Shes sell patak an' you call eet gardeng?" I still answered no. "Vell," he says, "Not know Yoseph, by jee he's de bess raffs man on de Ottawah, 'e coma down de Soo pass Carrillon, 'e roun' de St. Anne jump a Lachine a canal, a crack a two steamboat; by jee, Not know Yoseph, eh?"

THE Crooks act has done much towards doing away with shebeens which flourished on the roads between civilization and the bush, but in many sections, although frowned upon by boss lumbermen and all foremen with the interests of their firm at heart, they continued to vend whiskey *Blanc* and swamp whiskey a standing menace to peace and good will amongst crews who on their road to the shanties stopped for a meal or rested over night. On one occasion a crew under a strict foreman had reached the last stage but one of their overland journey. They put up for the night in a log building, constructed, furnished and stocked to meet the requirements of a shanty man, but unlicensed. In spite of the vigilance of the foreman some evidently were drinking, and as evening wore on some became drunk. The foreman remonstrated with the landlady and tried to frighten the landlord but without avail. He finally heard a rumour in a back room off the kitchen. The landlord was Highland Scotch and was serving a countryman. Two Frenchmen were endeavoring to force their way into the small room but were stopped. When the landlord emerged from the taproom, leaving his companion locked in, he was interrogated as follows: "Monsieur, we Frenchmans, eh? we be Scotchmans, eh, we get the liquor? The landlord tried to explain that the foreman was raising a fuss, that he would get into trouble, and as a clincher he said in his best vernacular—"She'll no give to nobody an' last o' a' to a Frenchy". He had hardly finished speaking when, bang! one of the duett struck him in the eye and disappeared like a shot. Quick as a flash he let the remaining Frenchman have it in the jaw. The recipient on asking what he was thumped for was told: "She was hit richt on the e'e by yeer nepoor, she didna deservt—ye didna deservt, ga on' hit him".

### THE STURTEVANT DRY-KILN APPARATUS.

THE marked efficiency of the Sturtevant dry-kilns has always been attributed to the high grade of apparatus by which they are operated. Not content with a good thing, the attempt has always been to manufacture a better one, and the ever increasing trade in this line is the best evidence of the wisdom of this course. With the growth of the kiln business, the tendency has been toward the massing of kilns in single batteries, each operated by a single large apparatus. In large batteries the air ducts are of necessity usually underground, requiring the fan to be likewise placed if it is to discharge directly into the duct. To meet this requirement and at the same time reduce the cost of the fan, the B. F. Sturtevant Company, of Boston, Mass. several years ago introduced a type of fan with only three-quarters of the regular full housing, the lower portion being constructed of brick and forming at the same time the end of the duct. Such a type of fan, with engine connected directly thereto, is shown in the illustration herewith presented which represents the latest style of Sturtevant steel plate steam fan, with three-quarter steel plate housing. The arrangement is very compact, and as will be seen, when the room is floored over nothing appears above the surface but the engine and fan housing. The sides of the fan are rigidly stayed by angle irons; the fan wheel itself is carefully balanced and mounted on a steel shaft, which forms the main shaft of the engine. This engine is built by the above named company, and is exactly of the same grade as their automatic engine, the best provision being made for oiling all running parts, the bearings all being of large size, in fact, everything conducive to the continued running which is always necessary in kiln plants, has been introduced. The heater which always accompanies this fan, is not shown in the illustration, but is made up of a series of cast iron sections, into which are screwed vertically rows of steel pipes, the upper portion of each section forming the steam and the lower the drip passage; the upper passage being divided midway so as to compel the steam to pass up, over and down the pipes. The entire heater is encased in a steel plate jacket connecting with the inlet of the fan. This jacket, as well as the heater sections, is supported on a substantial angle-iron frame foundation. Expansion of the heater sections is allowed for by the balls which are placed beneath one end. These sections are bolted together in groups by bolts extending entirely through the headers on one end, so that steam connections may be made with the end of the group and the drip may be removed at the same end, obviating the objection to other styles of heaters, having the inlet and drip upon different sides of the heater. Heaters of this class can be built in large groups of many sections, but their arrangement can only be determined by experience, as the greatest efficiency of the heating service can be best secured by a proper proportioning of the number of rows of pipe across which the air is drawn. These heaters are arranged to be operated by either live or exhaust steam, generally by exhaust steam from the mill engine during the day and by live steam during the night. The exhaust from the fan engine is always utilized in the heater, so that the motive power counts for nothing. The manner of application of this type of apparatus to the Sturtevant kiln is already well known, the air being forced in through inlets at one end of the kiln, and in its passage down through the kiln, coming in contact with every foot of lumber, and finally escaping at the opposite end of the kiln, the lumber being laid upon cars and pushed forward into the warm air. This gradual action results in thoroughly drying every part of the wet lumber. Lumber and stock of all descriptions, including staves, heading, kindling wood, shingles, spokes, woodenware, etc., can

easily be dried in the Sturtevant kiln when properly arranged. In many woodworking establishments, such as furniture and carriage manufactories, the same apparatus is used for heating the building and drying the lumber. Whenever the air escaping from the kiln is too moist it may be utilized in heating a portion of the building.

The Sturtevant system of heating has been extensively introduced and has proved a success in every way. Its peculiar advantage lies in the massing of the entire heating surface in a single heater, instead of stringing it all over the building as in the case of direct radiation. The amount of heating surface required is thereby reduced to about one third of that ordinarily provided. There is no opportunity for the freezing and leaking of exposed pipes with their consequent damage. Ventilation is provided with the heating, and owing to the pressure produced within the building all leakage is outward. The same system is applied to all classes of buildings, schools, houses, public buildings, etc., as well as manufactories.

### A RAILWAY COMMISSION.

WHETHER we should have a railway commission or not is the question that every now and then seems to disturb the minds of our great army of shippers and

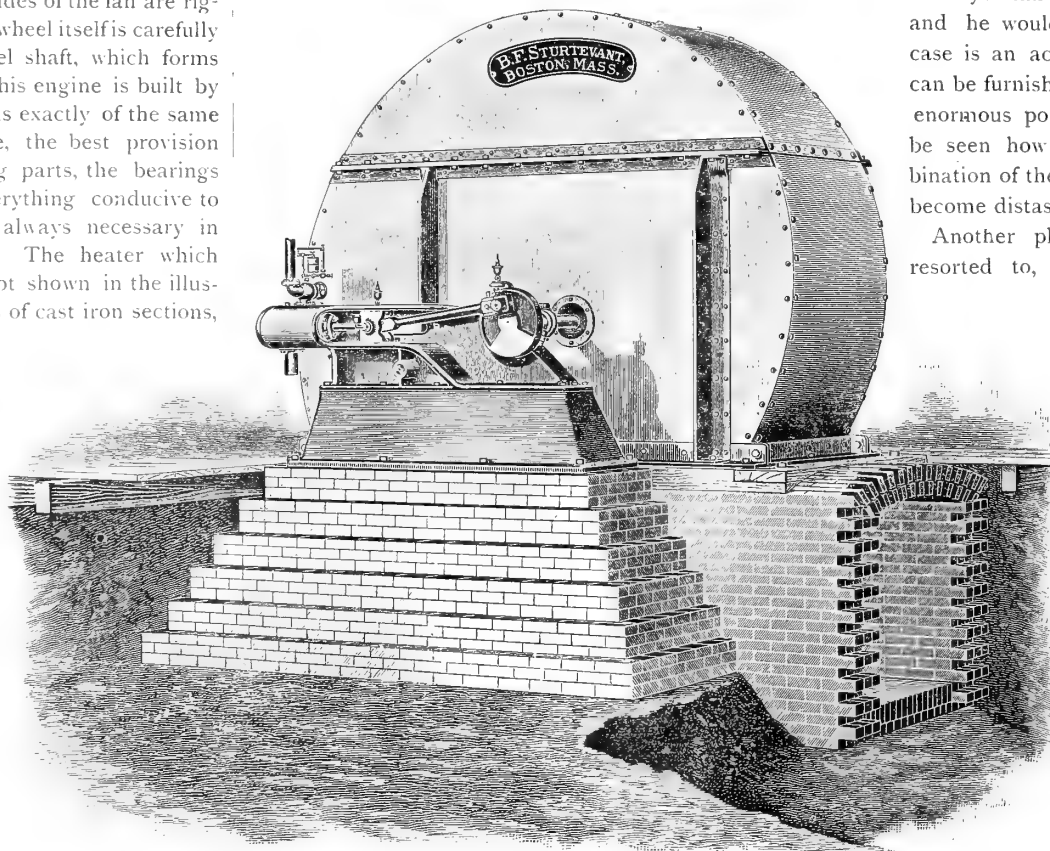

THE STURTEVANT DRY-KILN APPARATUS.

handlers, and it is the purpose of this journal to gather and give to its readers all the information and opinions available on the subject. A Railway Commission is a court just the same as any other court for the hearing and deciding of cases in dispute, with these differences, viz: its proceedings are of a summary nature; every facility is offered for the hearing and deciding of cases brought before it; no legal counsel need be employed, and hence it is much less expensive. Its powers would be much wider than any court now existent in that it would decide all matters of dispute between railway companies and corporations, which have now to be referred directly to the Legislative body as represented by the Railway committee at Ottawa. It would in all probability be made up of a capable legal gentleman, a business man, and a railroad expert, or engineer, so that all sides and shades of opinion would be fairly represented. The costs of this court would be very much smaller than those of our superior courts. It would give summary and final judgment upon all cases of alleged extortion or unfair discrimination on the part of public carriers. That there is a pressing need of such a court is already apparent to nearly all who are engaged in heavy freight handling, but for the benefit of the few let us suggest some good reasons for its establishment.

The present arrangement is so cumbersome and distant as to be practically beyond the reach of any but the largest corporations, or those who can afford to spend large sums of money to obtain a measure of justice. Now it is well known to every reader of this journal that our railways have been in the habit of giving discriminatory rates to large shippers or favorites, a practice which is very much to the disadvantage of the business of those not so favored, and it has been all but impossible for business men so placed to have this very apparent injustice remedied, notwithstanding the fact that it is contrary to law as well as right. They would either have to proceed in a court, which could not compel the production of the evidence necessary to make a good case, or go to the expense, trouble and loss of time necessary to carry the case to the railway committee at Ottawa. Then even should they join issues against the company their position would be a very unenviable one, because it is a well known fact that it is in the power of these monopolies to ruin the business of many of the people dependent upon them for shipping facilities. Take a case in point: Two men are buying wheat at G—; to one of them the company gives a rate of 12c. per cwt., to the more favored one 10c. per cwt. It is very plain that the second buyer can simply put the first off the market, and he would be compelled to quit. The case is an actual one and names and dates can be furnished if necessary. Now with such enormous powers in their hands it can readily be seen how a railroad company, or a combination of them, could ruin any one who had become distasteful to them.

Another plan, which is not infrequently resorted to, is the granting of a ready supply of cars to the favored shipper and the withholding of the same from those whom they are not anxious to serve. That this act of tyranny has been perpetrated again and again, the testimonies given to the committee of the Toronto Board of Trade on shortage of cars more than proves, for it shows that our grain dealers, lumbermen and millers are annually made to suffer severely, and there does not now seem to be any means of abating this evil, save by placing the control of the matter in hands capable of dealing with it. That the matter of special and discriminating rates was amply proven by the sworn testimony of the chief freight agents of both the G.T.R. and C.P.R., as given before the Royal Commission at Montreal, where they explicitly declared that they have general rates, special rates and "special" special rates. Then again they are hurting very seriously the shipping trade of this country with Great Britain and the continent, and the amount of which they rob the Canadian farmer annually foots up to something in the millions. In the testimony given at Montreal it is asserted that the Canadian roads have lost money upon the carriage of American freight, while in the same examination it transpires that the roads are making money. Now there is but one deduction which we can draw from this, and it is that the Canadian shipper and farmer is made to pay the losses which these roads have made in their unfair fight with their Yankee competitors. But we have other proof than that deducible from their own sworn testimony. We can adduce abundant evidence to show that the Canadian roads make a general practice of carrying flour, grain and other heavy freight, cheaper from Minneapolis or Chicago to the seaboard than from Toronto, not to mention Winnipeg or other points which would be entitled to the same rates at least. Now Toronto is at least 800 miles nearer the seaboard than Minneapolis, and 500 miles nearer than Chicago. While the C. P. R. were carrying wheat and flour from Winnipeg to Toronto at 47 cts. per cwt., they

charged but 15 cts. per cwt. from Minneapolis. The general freight agent of this road explains this very marked discrepancy by his statement that they made a practice of carrying foreign freight upon which there was a duty at such a reduction of rate as to set off the duty and create a foreign competition, and thus make carriage for the road. Thus it will be seen that while our government are using every endeavor to foster home industry, these roads by their unjust discrimination in favor of foreigners, are pulling down what is costing the country so much to build up. They are doing daily what the people of the United States would not suffer for twenty-four hours.

These monopolies, largely built up by the people's money, scout the very idea of the people having the slightest say in the fixing of the rates, and they tell us without hesitation that they know more about our business than we do, and that they, in their almighty beneficence, fit the burdens to the backs best able to bear them, meaning, we presume, the Canadian people as being better able to pay exorbitant rates than our neighbors to the south.

There are a great many other considerations which might be mentioned, such as the granting of rebates and special concessions, but space forbids us noticing them this month. Let us look, however, for a minute on a few reasons why a commission would largely do away with these evils. In the first place it would be independent of political influence. Now with all due deference to the powers that be there is not a doubt but the railways have an immense influence over the committee at Ottawa, and there is not a shadow of doubt but the placing of these roads in the hands of an impartial commission, which would be beyond the control of votes, would be a grand move in the right direction. In the next place this court would be held at different places throughout the country. It would be within the reach of every man who had a grievance, and it would no doubt become in a short time one of the most popular of our courts, and finally curb the rapacity of the railways to such an extent that they would cease to make cause for complaint. It would afford a quick and cheap means of obtaining justice at the hands of such a court; it would be a means of stopping all the discrimination in favor of foreigners at our expense; it would in fact place public carriers in the position of public servants, instead of being our masters as they now are. We would like to have the opinions of our readers upon this question, and would take it as a special favor if they would write their views concerning it. Such opinions will not be published if so desired.

#### DO YOU LACK STEAM?

**W**E here illustrate the Gordon Patent Hollow Blast Grate and apparatus, manufactured and sold by the Gordon Hollow Blast Grate Co., of Greenville, Mich.

The Blast Grate itself is a hollow cast section with suitable blast openings in its upper surface for the escape of compressed air to fan the furnace fires.

These blast openings, called valves, are about 7 inches in diameter, and are so designed that, though the compressed air may readily escape through them, the ashes and fine particles of fuel cannot drop through into the hollow space beneath. Each Blast Grate is supplied with from three to five of these valves, according to the length of the Grate. The Grates are uniformly eight inches wide by 4 to 6 feet long. Each valve is to all intents and purposes a "Tuyer iron" or "Duck's nest," such as is found in every blacksmith's forge, and the fire underneath a single boiler, fitted with these grates, will be quickened as though a dozen muscular blacksmiths were "pumping" with might and main upon a like number of bellowses, whose blast outlets were distributed about at regular intervals throughout the furnace. In this case, however, a fan or blower of suitable capacity supplies the place of the bellows, while the muscular arm of the blacksmith is supplanted by the steam engine.

As will be seen, the main blast pipe penetrates the side wall of the furnace at the floor line, extending thence across the ash pit under the back end of the Grates. As the blast pipe is at times subjected to considerable heat it is of cast iron, with heavy flanged

joints accurately fitted to make it air tight. From this pipe 4-inch vertical connections are made with the Blast Grates above. When in position for use this main blast pipe lies on the floor of the ash pit well back against the wall supporting the back end of the Grates. It is thus quite out of the way of the fireman when cleaning out underneath.



A HOLLOW BLAST GRATE.

The cast pipe usually terminates at the outer line of the furnace wall. Here a Blast GATE is attached, which, as it is opened or closed at will gives the fireman absolute control of the blast and consequently of the fire. Light galvanized iron or tin pipe, is employed to make the blast connection between the outer, or gate end and the Blower.

As will be seen, the apparatus, which is simplicity itself, consists of Blast Grates, Blast pipe and Blower. As from 200 to 400 cubic feet of air is forced through each Blast Grate per minute, it is sufficiently protected from injury by heat, consequently the claim that barring accident, the Hollow Blast Grate will last for a lifetime, seems plausible.

The Hollow Blast Grate is the invention of Alonzo J. Gordon, of Greenville, Mich., who may be said to have had life-long experience as fireman, engineer and mill owner and operator. The problem Mr. Gordon set out to solve was this: A simple and durable contrivance that shall ensure the quick combustion of such fuels as, with the ordinary draft, burn so slowly as to be practically worthless for steaming purposes. Prominent among these may be named fine dust from the band saw, spent tan bark, together with the dust and mill waste from such slow burning woods as Hemlock, Cypress, Gum, Elm, Oak, Basswood, Redwood, Cottonwood, etc., etc.

Mr. Gordon claims he has successfully solved this problem, and his Company proudly boast that they have yet to learn what failure means. Though the Blast Grates have now been in constant use for upward of two years, we are informed they have not in a single instance failed to secure the hearty endorsement and approval of the users. And what is more, though they have been subjected to practical tests in nearly every state in the Union, and under all sorts of conditions, not one has needed repair, not one has shown the slightest evidence of warping or sagging, not one has failed to perform the work set for it, in a manner highly satisfactory to the user.

Their proposal with Guarantee tends to inspire confidence. Reduced to its simplest terms it is this: "If you will give the Blast Grates a trial, we guarantee you shall be so well pleased with their work, that you will accept and pay for them at the expiration of the trial period."

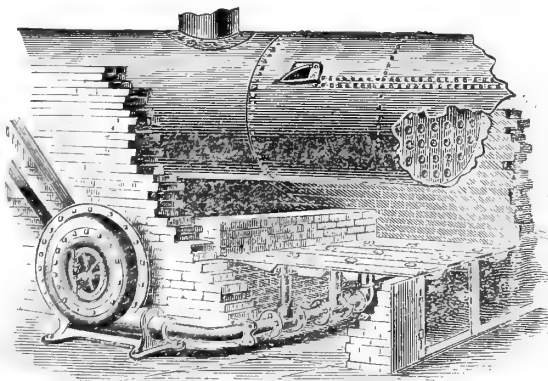

FURNACE FITTED WITH HOLLOW BLAST GRATES AND APPARATUS.

When using the Hollow Blast Grates the fires are fed exactly as when using grates of the ordinary pattern, by carrier, or through the open doors, with dust, spalts, slabs, blocks, or other coarse and heavy fuel. It is further claimed for these grates "that they increase four-fold the life of the common grates used in conjunction with them." This claim is based upon the theory that as the Blast Grates do all the work, the intermediate grates are practically relieved from duty, and as a consequence do not get heated sufficiently to "burn out."

As the Blast Grates are usually placed 8 inches apart

throughout the furnace they occupy only one-half of the Grate surface. The spaces between Blast Grates are filled in with common or saw-dust grates of an ordinary pattern, thus providing ample draft opening for steaming purposes, when the Blower or Fan is used.

#### A LIVERPOOL AUCTION SALE OF TIMBER.

**A** FEW minutes before the hour of noon strikes out from the tower at the Alexandra Dock members of the timber trade may occasionally be seen converging to some spot upon the quay of the Canada or Brookiebank Docks, the chief seats of the timber trade of the port. A stranger asking for information upon this matter would probably be told that an auction sale of foreign timber was about to be held. His attention might also possibly be drawn to the fact that a flag was flying from an imposing staff at the office yard of the firm of brokers whose sale was the object of attraction. This ensign might be the red, the blue, or the white St. Andrew's cross, for nearly all the different firms of brokers have their distinguishing flags. A brief space of time may be spent in walking over the logs and examining the merits or demerits of the cargo or cargoes to be offered. But probably all, or nearly all, with the exception of the buyers from the country, have scrutinised it most carefully since the first portion of it has been landed from the ship in which it was imported. But time is passing, and as the last stroke of the clock is heard there is a general concentration of the scattered assembly towards the auctioneer who has taken up his position on one of the most prominent places upon the cargo that is to be offered by him. The conditions of sale are rapidly read through and the real business of the meeting begins. With a few preliminary remarks, careful and guarded from one auctioneer, genial and humorous from another, buoyant and optimistic almost to extravagance from another, each according to his particular humor descants for a brief space either upon the excellence of the goods to be sold or upon any other phantasy that seizes his imagination. These being closed a silence ensues and an onlooker begins to wonder why all these people took all the trouble to come all this way for the evident purpose of all doing nothing. And all this, to, if it be in winter amidst a bitter, biting frost, quays as well as timber covered with snow, or if in summer to broil for an hour or more under a scorching sun at noon-day, and all this with evidently no purpose at hand. "Who bids for lot one?" cries the auctioneer. The silence remains unbroken, but at last some careful buyer makes in an equally careful and hesitating voice, in a very careful and lower pitched voice a bid. It may possibly be near the value of the goods or it may be a long distance away from it. But if it serves no other purpose it serves that of breaking the silence and once this is done matters progress rapidly. Bid follows bid and lot after lot is quickly knocked down. The cargoes if not sold as we have endeavoured to describe are just as promptly withdrawn. Here we may say that provincial sales differ widely from those held in the metropolis. It has often been a matter for consideration why there should be such a wide divergence in the method of holding auction sales in the two great centres of the timber trade of this country. But the reasons are not far to seek. In London merchants conduct their business in the city and hold their stocks miles away at the docks. In Liverpool the very reverse is the rule. Here the merchants not only hold their stocks at the docks, but they hold them in the yards attached to their offices there, or in adjacent storage lands, and they have the further advantage of seeing their cargoes landing in many cases almost under their office windows. Under these widely divergent circumstances, there is no wonder that what should be found suitable for London should be found quite the opposite for Liverpool. Some years ago, efforts were made by various brokers to institute the London system here, but for the reasons set out above these did not succeed. It suited neither the merchants at the Canada Dock to leave their offices and waste many valuable hours of time in the city, nor did it suit buyers from the country to come down solely for the purpose of attending an auction sale and then afterwards to have to make a long journey, often late in the day, to find something at the docks they require to supply some want.—*Timber Trades Journal.*



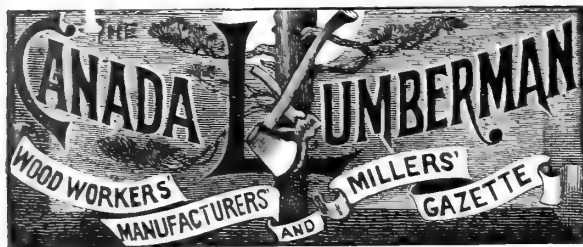

PUBLISHED MONTHLY BY

ARTHUR G. MORTIMER,

OFFICE:

75 CANADA LIFE ASSURANCE BUILDING,

TORONTO, ONTARIO.

TERMS OF SUBSCRIPTION:

One Copy one Year, in Advance, - - - - - \$1.00  
One Copy six months, in Advance, - - - - - 50

Advertising Rates Furnished on Application.

THE CANADA LUMBERMAN is published in the interest of the lumber trade and of allied industries throughout the Dominion being the only representative in Canada of this foremost branch of commerce of this country. It aims at giving full and timely information on all subjects touching these interests, discussing these topics editorially and inviting free discussion by others.

Especially pains are taken to secure the latest and most trustworthy market quotations from various points throughout the world so as to afford to the trade in Canada information upon which it can rely in its operations.

Special correspondents in localities of importance present an accurate report not only of prices and the condition of the market, but also of other matters specially interesting to our readers. But correspondence is not only welcome but is invited from all who have any information to communicate or subjects to discuss relating to the trade or in any way effecting it. Even when we may not be able to agree with the writers we will give them a fair opportunity for free discussion as the best means of eliciting the truth. Any items of interest are particularly requested for even if not of great importance individually they contribute to a fund of information from which general results are obtained.

Advertisers will receive careful attention and liberal treatment. We need not point out that for many the CANADA LUMBERMAN with its special class of readers is not only an exceptionally good medium for securing publicity but is indispensable for those who would bring themselves before the notice of that class. Special attention is directed to "WANTED" and "FOR SALE" advertisements which will be inserted in a conspicuous position at the uniform price of 15 cents per line for each insertion. Announcements of this character will be subject to a discount of 25 per cent, if ordered for three successive issues or longer.

Subscribers will find the small amount they pay for the CANADA LUMBERMAN quite insignificant as compared with its value to them. There is not an individual in the trade or specially interested in it, who should not be on our list: thus obtaining the present benefit and aiding and encouraging us to render it even more complete.

#### TO VISITING LUMBERMEN.

LUMBERMEN visiting Toronto are invited to use the office of the LUMBERMAN as their own. We shall take pleasure in supplying them with every convenience for receiving and answering their correspondence, and hold ourselves at their service in any other way that they may desire.

#### THE DECREASE IN OUR TIMBER SUPPLY.

AT the outset it is to be understood THE LUMBERMAN has not made the discovery, which annually or bi-annually looms up in journals published in the interests of the trade, that our timber supply is giving out, in fact, well nigh exhausted. It is intended to briefly sketch the demands, the enormous demands, made every year upon forests in America, and to show that as a consequence the necessity must soon arise for some methods of preservation akin to those in vogue in Great Britain, Germany and France, or that the example of Russia to plant new ones, must be followed. Before the current year expires, the theoretical lumberman will cover about the same acreage of paper with resolutions at forestry gatherings as the acreage of timber which will be cut by the practical lumberman, and the columns of newspapers will contain contributions giving elaborate Utopian schemes for forest reproduction and preservation, as wearisome to intellectually wade through as blazed logging roads are physically wearisome to plod over. Some forty years ago in South-western Ontario there were remnants of vast forests of walnut standing. To-day, in some sections, you can find old rail fences and decaying stumps of this expensive, and almost annihilated wood. The early settlers, with a ferocity equal to Attila, looked

upon a tree as a foe, and every known means was employed to exterminate the common enemy. The counties of Perth, Oxford, Waterloo, Wellington, Huron, Brant, the best fall wheat district of the west, were heavily timbered with maple, beech, oak and pine. The same unsparing, ruthless, tree-thirsty desire seized the settler. Axe, saw and fire were kept steadily exterminating, until many farmers were years ago compelled to buy coal for fuel. Saw logs, square timber and the saw mill completed the devastation, and in place of being able to export lumber, if the timber had been judiciously manipulated, hundreds of places have to import for local consumption.

The fringe of settled land along the north shore of Lake Ontario, sections of New Brunswick, Nova Scotia and Quebec, all bear testimony to this wholesale destruction. The "logger" has now to operate limits 400 miles up the Ottawa. The sources, in place of the beds of the Rouge, the Gatineau, the Du Nord, the Bonnechere, the Mississippi, the Madawaska and the Mattawa, are where the shanties are now built, and in many instances this season's cut of logs will not be sawn until the second summer.

Bush fires started by pioneer settlers, careless hunters, heedless campers and tourists; fires lit by accident and design, have destroyed as much, and probably more timber than man has cut. The logger knows this and uses it to his advantage. "Look at the income from the sale, and the stumpage I pay the government; fire pays none. Cut it!" This is his motto and when a limit is opened by a lumberman possessed with these ideas, the timber disappears rapidly, if the market price allows a margin.

Looking over the reports of the cut in the large sawn lumber sections of the United States for 1890, we notice that our nearest neighbor, Michigan, is gradually falling behind as a white pine producer. The price of lumber, or the state of trade, has had practically no influence on the output, yet Muskegon shows in 1884, 615,447,398 feet, in 1889, 417,177,824 feet, and in 1890, 301,875,227 feet. In 1882 the Tittabawassee Boom Co.'s log cut reached the enormous amount of 611,862,670 feet. A decrease annually has taken place. On the Saginaw, the output for 1889 was 333,925,130 feet, against 302,525,530 feet for 1890. Not only is there marked decrease in the output, but the average size of the logs is smaller. One example will suffice to show this. In 1864 the logs averaged 243 feet, in 1889 110 feet, 1890, 106 feet. Log supplies are now being taken from Canada to recoup the serious falling off in the supply in some districts, and in others the mills are either closing down or following the forests for logs to keep the saws going. What is taking place in Michigan timber limits is also taking place in Wisconsin and Minnesota—the white pine considered inexhaustible fifteen years ago, is quickly being exterminated. The supplies of the future cannot be cut from growing timber, they must come from old timber saved. The consumption of the pine in the States mentioned, proves that trees do not grow as fast as the logger fells them, and that, like walnut, the white pine of the North American Republic will dwindle to clumps and specimens. Its place will either be taken by white pine from northwestern Ontario, or yellow pine from the middle and southern states. This article is slowly pushing its way into the northern markets, and just as northern pine diminishes in quantity and increases in price, the yellow pine will be accepted as a substitute. Destruction began long ago in Georgia from the demand for turpentine, and it is estimated that 33 per cent. of the standing timber of that state has been killed within the last ten years. The acreage of yellow pine timber is not like the acreage of Canadian white pine, vague and indefinite; it has been measured. Allowing 4,000 feet of sawn lumber per acre, and the capacity of a mill 50,000 feet per day, in 25 years the single mill would denude 100,000 acres. Given, the acreage and the total yearly cut of the mills, the time when yellow pine will follow the fate of its northern sister can be approximately calculated.

The craze for quartered oak, antique oak, and reliefs found by panneling with plain red and white oak lumber, has forced the price of that wood away into the teens in Canada, and small mills whose yards a few

years ago contained unsaleable piles warping and rotting, are now taxed to their utmost capacity. It is not a plentiful wood in the Dominion, and its natural production differs from all other varieties of trees. It is only a question of time, a very short time, when it will be like the Buffalo, historical. The tan oak of California, once covering thousands of acres, can now almost be counted on the fingers in many counties, and steps have been taken for replacing it with an Australian variety of the eucalyptus. Oak in the United States is not so general or so inexhaustible that it can stand the inroads made upon it for the last three years. It must be nursed if it is to continue the leading wood for furniture. On the Pacific coast, in both Canada and the United States, the annual cut of standing timber without any attempt to conserve the forests must, in the course of time, denude that part of the continent. It is not in the felling of matured trees that objection can be made, for timber like the lower orders of vegetable matter and all animals arrives at maturity and dies. It is in the wholesale slaughter of unmaturing trees the evil lies. Half grown specimens and acres of smaller ones cleared off with the axe simply means, if coming generations are to handle logs like their grandfather's handled them, some method apart from theorizing and visionary private ones must be applied by lumbermen themselves. Their main desire is to swell the bulk of the figures given on the enormous consumption of timber at last year's forestry meetings, and to skin their limits of everything saleable, leaving their successors to fish for timber as best they can.

#### THE INFLUENCE OF CANADA LUMBER IN THE UNITED STATES.

CONSIDERABLE discussion in papers and journals has been provoked by the utterances of Geo. P. Smith, a lumber dealer of Tonawanda, N. Y., in an interview reported by the *Detroit Free Press*. Much of the interview is foreign to the Canadian trade, but amongst the items the following is found:

"The effect of the reduction of the import duty on Canadian lumber from \$2 to \$1 a thousand has been to bring into the United States considerable quantities of the coarser grades of lumber, which before could not afford to pay the duty. The Canadian bill, removing wholly the export duty of \$2 a thousand on logs, was passed too late to be of any effect this winter, but the indications are that by another year large amounts of Canadian logs will be sawed in American mills." The influx of coarser grades of Canadian lumber in the eastern market, is quite likely to effect the American product in the east. An eastern Michigan manufacturer stated a day or two ago that the call there was largely for good lumber, while the coarse stocks dragged, and he attributed it to the Canadian stocks being placed by rail upon the American market. As the stocks now being manufactured in eastern Michigan, owing to closer cutting, are largely coarse grades, it looks to a man up a tree as if the Michigan coarse product would drag like the Dickens before closing-down time comes next fall. This condition of things has been feared by Michigan manufacturers a long time, and largely influenced them in opposing a reduction in the import duty on lumber. "It is true," said one of them, "that there is still a duty of \$1 on Canadian lumber imported to the United States, but the difference in freight between Canada and the eastern market is fully \$1 a thousand in favor of the Canadians and I expect that coarse lumber will be sick. And it is these coarse stocks that have helped the Michigan manufacturer out. They have enabled him, by reason of placing them on the market at a fair profit, to cut his lands close, and thus even up the cost of stumpage, which has been higher in eastern Michigan than in any other part of the northwest. I am apprehensive that this coarse Canadian lumber thrown upon the eastern market will prove a serious affair to Michigan manufacturers."

The *Timberman*, of Chicago, in challenging the statement, clearly shows, by giving the prices obtained in *bona fide* sales, that at least in the cases quoted prices have not fallen, and winds up its proofs in the following language:

"It will be of interest to say by way of emphasis, that one Buffalo firm, a near neighbor of Mr. Smith's, has purchased at Menominee this year a stock of lumber from a firm from which they have bought during the past six years, (some 40,000,000 feet) at \$17.50. Hitherto the Buffalo firm has purchased this Menominee firm's stock of lumber by inspection. They will take the lump lot on a basis of \$17.50 this year, and in the six years they have bought this firm's lumber, they never paid a price approaching the above named figures, considering the inspection of matters, within \$1.50 per thousand feet as much as they pay this spring. Having said as much in refutation of the charge that prices have been constantly lessening during the past five years, we will say, that whereas some of the lower grade lumber has been reduced in price, such change is not permanent, and even with a reduction in the Canadian tariff during the past year, prices of good lumber as above indicated have advanced. Instead of saying, as Mr. Smith does, that the price of pine has been reduced

during the past five years, notwithstanding the growing scarcity of pine, we fail to hear of any lumbermen who hold pine, getting into the "financial cramps" of which Mr. Smith speaks, because of holding pine; and if he expects to see white pine stumpage decline in the ratio that his cordwood declined, as he narrates specifically, his expectations will never be realized.

The *Timberman*, we believe, is nearer the truth than Mr. Smith on the question of pine prices; but suppose a sudden demand arose and prices stiffened would the rush from the white pine states—and let us include Canada with the dollar duty against her—force the price down, or would the increased, or raised, price allow yellow pine holders to get their stocks worked off at the market quotations for that wood? This factor in the home market of the United States is now a prominent one with Canadian shippers of coarse grades, and when Canadian coarse grades meet in competition with yellow pine, planed or almost ready for domestic use, the keenest of competition follows. Clean stocks of white pine are not subjected to the same competition and we have no hesitation in saying that Michigan men have more cause to fear southern pine as a price lower than they have of Canadian culls.

### RECIPROCITY.

UNDER the heading "Against Reciprocity," we republish the opinions of the *Northwestern Lumberman*, Chicago. We have never questioned the value of reciprocity in lumber to Canada, but we have in a variety of ways asked our contemporaries who clamor for it and blame the government for not obtaining it to show us the *open sesame*, to show us how it can be obtained. Before another issue of THE LUMBERMAN the representatives of the Privy Council of Canada will have opened negotiations of a reciprocal nature with the authorities at Washington. It is not known whether lumber will come under discussion or not. If so, the daily report of the proceedings will be doubly interesting; if not, the articles under discussion will, in a measure, include difficulties similar to or inherent to the lumber interest.

If no other product of Canada were involved, and lumber *per se* was the bone of contention, *i.e.*, if the commission under Sir Charles Tupper, who, as he puts it: "Themselves a branch of the Anglo Saxon race, thoughtful Americans need not be told that a sister branch of that remarkable stock may be won but cannot be coerced, and that if negotiations are entered on Mr. Blaine or his colleagues will not be actuated by any other thought than the making of such an arrangement as will accrue to the benefit of the American people." If this commission met to arrange free trade in lumber only it is the opinion of the most profound thinkers on the subject that it would never be granted.

We recognize the opposition from Michigan, Minnesota, the southern pine states, and to some extent on the Pacific coast. On the North-eastern slope of the Atlantic, and in the states directly south of what is known as old Canada, is situated a section of the American Republic that is compelled to buy from three outlying portions of the continent. From Canada on the N. E., N. and N. W. by W., from sister states to the S., S. W. and W. and from the N. W. White pine men in the states will find enough to do to attend to the cheap stumpage and nigger labor of yellow pine without being bothered with the products of the older provinces of Canada. One enemy in the front is sufficient to fight without an enemy on the flank. Yellow pine men are pushing their manufactured stuff against a common foe, the one crippled by geographical position slightly, the other handicapped by the duty.

The position cannot be altered, but it can scarcely be expected that an auxiliary in the fight, such as duty, will be thrown away without a strong effort being made to retain it. That white and yellow pine men would join hands, and that the interests of mill men in the N. E. States, who operate on the residuum of pine on the Alleghenies would go with them would be a certainty. If the question of reciprocity in lumber is discussed in conjunction with our other productions, the same influences will be brought to bear. It will not be from a mill man's standpoint, what is best for

the welfare of the manufacturing states of the N. E. Atlantic coast; it will be what is best for myself. We repeat that whatever shape the negotiations assume, the interest taken in them will be greater than in any friendly attempts at reciprocal relations since confederation. Almost a new nation sways the future of Canada since '67. Those old enough to recognize the significance of the event at the time; even the urchin who fired off his squibs on our first Dominion day wondering what the fuss was all about, have now a vote, and take a deeper interest in their native land than could be expected from their fathers who adopted it. The school master has been abroad for the last quarter of a century, and every twist and turn of the proposed negotiations will be argued, self-construed, self-interpreted and willfully tortured to suit the political exigencies of the case.

## EDITORIAL NOTES.

WE want a few copies of the LUMBERMAN for March, will some of our friends kindly remail their copies to the office of publication, Canada Life Building, Toronto, we will look upon it as a great favor.

LIKE Homer's, the birth-place of the inventor of the circular saw is a doubtful quantity, and several places dispute the location of his graveyard. Now that mills are being opened for spring business many an employee will not be particular as to the inventor's graveyard, but it is quite possible they will wish that he never was born. Disciples of Esculapus and knights of the scissors owe considerable to the circular.

THE New York *Press* cartoon is very *apropos* to the discussions and attempts recently made to conserve the forests still remaining in the Adirondacks. The Adirondack Lumber Company appear in the foreground felling trees. George Washington, of hatchet and cherry tree fame, sticks his head out of the zenith and is represented as remarking: "and to think I was reprimanded for cutting down one little tree."

CANADA on both seaboard has taken the lead in cultivating the lumber trade in South America. Foreign lumber markets are not any too active in Europe and stagnation describes the condition of South America. The Argentine Republic is in the throes of a cramped money market; Chili is engaged in war and political troubles are effecting Brazil. Until these are removed the demand will not improve.

THE scarcity of cars to remove lumber that was experienced last year on the G. T. R. will be somewhat lessened this summer. There will be little increase in rolling stock, but the release of a great many cars from work on the Sarnia tunnel, the very small quantity of square timber manufactured in the North and no ice to move will lessen the demand in their respective requirements. It is to be hoped a repetition of last season's experience will not be incurred.

THE McKinley Bill clause placing a duty of 20 per cent. *ad valorem* on cedar ties and posts went into force March 1st. Its effect on this trade in Canada is problematical as yet, but before long we will be in a position to report any lowering of prices as some anticipate. Last year the Province of Quebec marketed \$78,000 and the Province of New Brunswick \$77,000 worth.

"James Blair, of Ferguson's Falls, is home from the shanty with a full pocket, a fat team and a cheerful countenance."—*Ex.* James differs from a great many logging teamsters this winter. Many of them in the Ottawa valley returned leaving their horses at the bottom of a lake or river, or food for crows on the bank of a stream during the summer.

A STURGEON BAY man writes: "As the new season advances, the vast quantity of logs and other timber from the forest continue to augment and fill the streets." This is a sample of the new figures of speech styled "back-handed adjectiveness and the vagueness of seductiveness". How did the logs get there? Were they rolled, dumped, canted, hauled or felled? Does the "vast quantity" mean last year's logs left in the streets for lack of water to drive or what does it mean? Augment is good; try again.

BRITISH COLUMBIA is steadily pushing her way into the lumber markets of the world. Sample cars of assorted sawn lumber and samples freighted by water by the enterprising firms who operate her mills are doing much to advertise the productions of our youngest colony. The latest move is worthy of special notice. The full rigged ship *Titian* was chartered at Shanghai, China, to carry from B. C., *via* Cape Horn, for the G. W. Bush & Sons Lumber Co., of Wilmington, Delaware, 1,000,000 feet of sawn lumber.

AFTER all Canada is rather a fine country to lumber in. The heaviest snow fall of the season took place on the 8th ult. in North Michigan, Wisconsin and Minnesota, decreasing as it extended northward over Lake Superior and that district. Rivers in the southern parts of these States are full to the brim. In Ohio immense damage has been done to mill property and booms, while serious freshets have occurred in more than one eastern state. If the breaking up of Canadian waters takes place as gently and easily as reports state up to date no cause for grumbling can be found.

THE annual number of the *Timber Trades Journal*, of London, England, the leading British paper in its line, reached us last month. It contains 255 pages full of interesting and suggestive matter on the European as well as the foreign phases of the trade. Three supplements are also issued containing half tone portraits of the hardwood dealers of the metropolis, the representatives of the timber trade in Newcastle and Sunderland and a portrait of a Liverpool timber auction. Amongst the advertisements a fair sprinkling of United States manufacturers' names can be found, and several pages are given to the illustration and description of United States mills in the Puget Sound district.

THE general regulations for foreign exhibitors at the Chicago World's Fair has been received. It is issued in foolscap size, contains fifty-four pages and the subject matter is divided into the usual departments, groups and classes. Class 99 to 118, inclusive, deals with forest productions and forestry. We have the authority of W. J. Buchanan, chief of the department of agriculture for the Fair, in stating that exhibits in this class will form one of the most complete departments. Already lumbermen in the Southern States of Georgia, Alabama, Texas and Missouri have appointed a special committee of eleven members to co-operate with the management. The Pacific coast U. S. men have also taken initiatory steps. What do Canadian lumbermen intend to do in the matter?

ANY one looking over a yearly list of fires and casualties in the lumber trade after sawing begins must be appalled at the fearful destruction of property, life and limb. Deducting from the aggregate all due to carelessness and design, the number is still vast enough to bring before millmen some of the improvements that will be forced upon them in a few years by the use of electricity. The main engine can be placed in any position in the yard with little regard to lining up. Wires can be carried in any direction; wire cables and shafting cannot. Applying motors separately to systems of shafting does away with cumbersome jacks, large pulleys, belting and economizing the space occupied by them. In the erection of new saw mills, planing mills and other factories, the separate motor to systems of shafting is worthy of serious consideration from a convenient and economic standpoint, as well as the minimising of accidents from automatic connection with the engine.

MANY of our readers have asked for a description of wood pulp making by the sulphite process. The wood is peeled, all decayed or off colored portions removed, and is then cut across the grain into thin strips. It is now ready for treating, and is placed in cylinders, or drums, capable of resisting a pressure of from 100 to 200 pounds to the square inch, and is covered with sulphuric and other acids in solution. The tissuey cotton like product is then pressed dry, mashed, mixed with water, rolled flat and cut for handling. It goes to the paper mill containing 60 per cent. moisture and 40 per cent. fibre. A cord of spruce yields 1,200 lbs. of graded fibre, worth from \$1.00 to \$1.50 a hundred pounds, and the plant to manipulate 8 to 15 cords in 24 hours is worth from \$6,000 to \$10,000.

SIX of the forest rangers, under the supervision of Mr. J. B. Charleson who was appointed as chief in 1887, reported to that gentleman last month their statements of accounts between lumbermen and the Quebec Government. Prior to Mr. Charleson's appointment a tax of 22 cents per log measuring 17 inches and over, and 11 cents on all under, was imposed. The abuse made of certain privileges; the evasion of the rules or laws on measurement; and the inadequate staff of rangers, led to some radical changes. More rangers were appointed, their work was increased and they were empowered to obtain a sworn statement from lumbermen, his agent or culler, and instructed to measure logs themselves as often as possible. The stumpage charge of 11 and 22 cents was abolished, and in lieu thereof \$1.30 is exacted for every 1,000 feet of timber, board measure. The cut of 1888-89 under this system netted to the crown lands department of Quebec \$1,200,000. Under the abolished system a greater cut of logs yielded \$864,000, or a difference of \$400,000.

FOR the last three years attempts have been made by the Norman, Keewatin and Rat Portage mills to form an association, fix prices of lumber, and hold to the agreement. There was formed over two years ago the North-Western Ontario and Manitoba Lumber Association, with rules of government and fixed prices, but some of the members departed from the spirit and tenor of the regulations rendering the scheme abortive. The managers of the various mills have been discussing the situation lately and have devised a plan which will be submitted to all the original millmen in the North Western and Manitoba Lumber Association. Messrs. R. A. Mather, D. C. Cameron and J. M. Cameron, of Rat Portage, are the delegates who will confer with Messrs. Jno. Mather and W. R. Fuller, of the Keewatin Lumber Co., and Mr. J. F. McCrea, of the Western Lumber Co. If the scheme is adopted, the new arrangement provides for the retention of the mills by the owners, but the products must be pooled. A central office will be opened to manipulate the output and the profits and losses will be settled on the basis of business done by each mill in the past.

AN Ottawa paper before the election which continued Sir John Macdonald in power as premier of Canada, a position which he has occupied since 1878, said in favor of unrestricted reciprocity "that it would bring back the box shoo factories which formerly employed hundreds of men, but had been compelled to move across the line, while it would also make Ottawa the great distributing point for the New England States, as all the lumber would be dressed there before shipment." According to this, Americans have cause to rejoice over the success of the conservatives.—*North-western Lumberman*.

The statements of hundreds of Canadian papers made during the late election, if published in pamphlet form, would exhaust in one issue the stock of quiet sarcasm our United States contemporary keeps in the sanctum. If some of them during a contest would say less about supposed results and give the means of putting their theories into practical usage the electors would thank them for being public benefactors. Our Ottawa contemporary has some extra pull on the Washington Senate, that the Canadian Legislature cannot be cognizant of, or else a seat in the house, say along side the Mace might be given it without the worry and expense of going to the polls. It will now be in order for the editor at the capital to open his bag of tricks.

It is agreed amongst men of experience that hardwood logs which float a long distance in water and remain months immersed in it give better sawn results than dry land stock. It is claimed, apart from any other qualifications, soaked logs produce lumber that does not check or split so readily as the dry land article. One of the most difficult hardwoods to market in good shape after leaving the saw is the oak family. Many a promising yard full of green lumber has turned out the opposite of expectations, and the further splitting and checking when in the hands of the mill to cut and split up, has always been a source of loss and annoyance. From the day the plank or deal leaves the saw the trouble begins. Oak is a slow natural dryer. Stocked in a mill yard to dry it warps, twists, splits and checks, and when finally drawn from a dry kiln the resemblance to the original for soundness is wanting. Since oak became so popular for cabinet work and furniture a great deal of attention has been paid to handling it, and it is claimed that a kiln that steams the wood by strong currents and rapid condensation of moisture is much better treatment than the hot air process. It is argued that the reason why it checks and splits is because the outside becomes dry and case hardened, while the inside is green. Before the moisture escapes from the interior it forces the grain apart and causes the defects.

It has become an accepted theory amongst the scientific world that geologically Australia is many centuries behind the rest of our planet. Her peculiar marine inhabitants, land animals, feathered tribes and her aborigines are the basis of the arguments, as well as the productions of the forest. They are almost as strange as the marsupials, and their description as given by Mr. J. Ednie Brown, of the forest department of Sydney, is decidedly interesting. Silky oak, a soft variety, grows to the height of 75 feet and is used for furniture. Forest Oak and Beefwood, so called from the streaks of color similar to the fat and lean of beef, are both classed in the old world's oak family from a supposed resemblance only. But it is not in the oak family alone that misnomers occur. So many odd specimens were found by the early settlers that names had to be invented to distinguish them, and the barkless peculiar fibred trees were christened as near as possible to counterparts in the old world or after some substance which they resembled, hence there are found satinwoods, blackwoods, whitewoods, rosewoods, sandalwoods, marblewoods, and the ash family, the latter looking very unlike the American specimen. Trees being found in great variety outlandish nomenclature had to be resorted to, and dogwood, stavewood, pigeonberry, union nut, myall and myrtle are in the forest vocabulary. Discrepancies occur in the nomenclature of the American continent woods. The Douglas fir is a spruce. Oak of commerce is divided in two classes, red and white, but there are thirty-seven varieties found. The true poplar is a willow. The gum tree of the Southern States is a hazel. Red cedar and our white cedar are not of the pine family; the former is a juniper and the latter a cypress. The yellow poplar of commerce imported into Canada under the name of whitewood is a tulip and the only one of its variety in America.

THE *Free Grant Gazette*, published at Bracebridge, directs the attention of its readers to offers made from United States firms for Black Ash, Basswood and Pine shingles, and cites amongst them a letter from G. Elias & Bro., of Buffalo, to Mr. A. Boyd, of Monck, as a sample case. The Buffalo firm offer \$22.00 for ash, and \$17.00 for basswood, The wood to be well manufactured and first class in every respect. The *Gazette* comments on the letter thus:

The prices offered above are about double as high as the Toronto dealers offered, and yet the duty is too high to admit of Mr. Boyd doing a profitable trade with the American dealers. But give us reciprocity, and then Mr. Boyd will make a pot of money in the timber trade with the Americans. So may other mill owners, who have the timber to cut, and farmers who have the hemlock, ash, birch and other timber to sell.

Waiving the hack cry "give us reciprocity," with out attempting to show us how to get it, we reply to the comparison drawn between Toronto and Buffalo prices

that the statement is not correct. Let us take the case of the quotation, F. O. B. at Buffalo \$22.00. Freight from Huntsville to Buffalo \$4.00, duty \$2.00, inspection and incidentals \$1.00, total \$7.00—balance \$15.00. Toronto price \$13.50 to \$15.00. On same grading and gid culling as Buffalo insists upon, any Toronto-dealer will give \$15.00 F. O. B. at the mill. Take the other case F. O. B. at the mill \$22.00. Duty \$2.00, freight \$4.00, inspection and incidentals, \$1.00—total \$29.00. The maximum price for picked in Buffalo is \$25.00 and grades sell as low as \$13.50. No one would ship at a loss of \$4.00 per M, not even our friend Elijah of the *Gazette*. These are hard cold figures to digest after publishing such siren and delusive clap trap as that contained in our clipping, but before an election a certain amount of license is allowed to party journals.

THE proverbial reputation of Scotchmen to get value for their money is not lessening; in fact the requirements contained in the specifications for the oak tender which we reproduce puts the desire beyond a proverb and stamps this particular Sawmie as a Scotchman amongst Scotchmen. In the Glasgow market recently there were tenders called for oak scantling, some 45,400 pieces, running from 6 ft. 6 in. to 18 ft. 6 in. in length; from 2 1/8 to 7 1/8 inches thick; and from 4 3/8 to 13 3/8 inches wide. Will our lumbermen read what is said regarding quality, then sit down quietly and ask themselves if in Canada with all her boasted forests could a mill be found that could fill the bill.

"The timber must be of the very best quality, thoroughly seasoned and free from rot, shakes, hearts, sapwood, wormholes, soft knots, large knots and all defects. The number of pieces required of each size is in the proportion shown in the list, and each piece must be sawn and cross cut exactly to the specified dimensions. Delivery is required in equal weekly quantities, beginning first week of April, 1891, and the whole must be delivered by the 30th of September. Each delivery must include a proportion of all the specified sizes in the list. No portion of the timber will be accepted as delivered to the company until it has been examined and approved by the company's inspector and found to be in all respects strictly in accordance with the specification and scantling. Should any portion of the timber which may be ordered not fulfill the conditions of contract, the company reserves the power to reject the whole, or any portion thereof. Please state in cubic feet the total which you undertake to supply, and quote net price per cubic foot, delivered free in wagons at this company's works."

AT one time salt sea salmon swarmed in the rivers flowing into Lake Ontario. Many old settlers have caught them in the Humber, the Trent, the Moira, and other smaller streams and in those tributary to the St. Lawrence. The erection of mill dams had considerable to do with stopping migratory fish, but the Dominion Minister of marine and fisheries blames the pollution of the streams from sawdust, mill rubbish and the refuse of factories for the destruction of fish life, the lower orders of life on which they exist and vegetation of every kind. He deplores the practice as a serious evil and confesses the difficulty in correcting it owing to the interference with a national industry. Speaking of the annual report a prominent mill man says: "Were it not for the serious impediments caused to navigation, and the probable sanitary evils that exist from the lodgment of sawdust in spots where the current cannot effect it, fish, like the buffalo, should go. You might as well expect to give up the mill and mill dam because the government devise schemes for the restoration of the Indian or the beaver." There is a grain of truth in the millman's contentions and a degree of comparison in his contrast. But much forbearance, if not long-suffering, has been exercised towards mill owners on the question of the disposal of waste, and the government can only describe the course that has been adopted as owing to the well known benefits of manufacturing interests. Enquiry on the probable cost of water power mills, and the destruction or utilization of waste, shows that it takes a small percentage of profits to provide against injurious effects.

THE official announcement of the opening of the Dominion Parliament for April 29th is made in an extra of the *Canada Gazette* dated the 17th March.



## THE NEWS.

## ONTARIO.

—Jos. James, a dealer in lumber, at Bridgewater, has assigned.

—The Meaford planing mill, recently destroyed by fire, is to be re-built.

—F. E. Barker's cut of logs at Northfield Centre, is over 500,000 feet.

—A new saw mill will be erected at Kingsville, by a Mr. Bradt, of Detroit.

—Field & Co's mill, at Staples, has been undergoing a thorough overhauling.

—Mr. J. R. Booth's mill at the Chaudiere will not begin sawing as soon as expected.

—Lassaline & Co. are rebuilding their furniture factory recently burned at Sandwich.

—Mr. Andrew Gordon is building a new saw mill at Minde-moya, Manitoulin Island.

—The estimated outlay on Mr. J. R. Booth's improvements on his Chaudiere mill is \$100,000.

—At present there is barely enough snow on the Keppewa to haul logs from the shanties to the drive.

—Mr. Bromley, of Pembroke, is in the Muskoka district buying pulp wood for the New York market.

—The Rathbun Co., of Deseronto, have purchased all the logs offered this winter on the Salmon River.

—The Toronto Hardwood Lumber Co. have removed from 83 Front st., west, to the Board of Trade buildings.

—At the Chaudiere and Hull large numbers of men are seeking employment on the drives and in the mills.

—Chalmers & Grant, of Kinlore, are about to dissolve partnership. Mr. Grant will run the saw and grist mill.

—The safe in the office of Lawrence & Son, lumber merchants, Sarnia, was broken open on Sunday 22nd ult.

—Navigation opened in the lumber trade on Georgian Bay by a schooner clearing for Windsor, loaded with deals.

—Mr. Blake Hill will run the old Fetterley saw mill at the Locks, Huntsville, for Rankin & Tennant of Toronto.

—Messrs. Wm. Fowlds & Son, of Hastings, will lose heavily by the breaking of their boom and escaped logs.

—Messrs. Perley & Pattee at the Chaudiere will have sufficient logs to run day and night shifts if occasion demands it.

—Duff & Stewart, of Bluevale, have cut a large quantity of logs and dumped them along the banks of the Maitland river.

—Geo. Lemerise, of Tilbury West, has invented a machine and applied for a patent for swaging, setting and filing saws.

—On 18th and 19th ult., snow fell so heavily in the Petewawa lumber camps that operations had to be suspended.

—A large quantity of cedar ties, paving and posts, have been cut around Providence Bay, Manitoulin Island, on speculation.

—Gall, Anderson & Co., J. Holbert and T. B. Tait, Burk's Falls, have secured sufficient timber to run their mills for the season.

—An unusual large quantity of poplar pulp wood has been cut this winter along the C. P. R. track at Chalk River and Cobden.

—The Vanstone property, Brussels, consisting of flour mill, saw mill, stores, land, etc., will be offered by public auction on April 2nd.

—E. Shaver, and Jos. Seeley, of Rowena, Dundas county, have the C. P. R. contract for ties for the eastern section in Ontario.

—McMillan's saw mill, at Blyth, has been undergoing repairs. A new boiler has been put in along with other improvements.

—The Cranbrook sawmill, under the management of Chas. Deames, will cut more lumber this coming season than in any year in the past.

—Mr. Wm. Niebergall, of Dunlop, who has operated the local saw mill for the past seven years, has gone to British Columbia to reside.

—Calder's mill, at East Wawanosh, has undergone a thorough repairing this winter. A new boiler has been added to the machinery.

—Mr. Hector McQuarrie, lumber merchant of Baysville, has been forced into assignment from heavy speculation in unproductive real estate.

—The Kidgetown saw mill, at one time owned by Moody & Sons, has been purchased by John A. Moody, who is fitting it up and will run it this spring.

—The South River Lumber Co. have finished operating on the South River, in Parry Sound, and are now engaged in hauling the cut to their mills.

—Mr. John Moran's limit, on the Coulonge and Black Rivers, has been purchased by Messrs. W. MacKay, sr. and A. H. Hough, of Renfrew, Ont.

—The Canadian imports in wood and manufactures of, for the month of January, exclusive of British Columbia, were \$63,576.00, the duty on which was \$17,480.81.

—North of Deseronto, during the past winter logging has been very active. Along the banks of all the small streams enormous quantities of logs have been dumped.

—Logging is over in the Sudbury district. Up to the middle of last month it was feared the scanty supply of snow would interfere with driving, its depth not being half what it was last winter.

—The imports to Toronto for January, 1891, footed up to \$623,503, against \$628,560 for January, 1890. The exports for January, 1891, were \$229,799, for January, 1890, \$180,805.

—The last supply train of the season left Ottawa on the 24th for the Desert up the Gatineau road. The supplies were intended for various firms and were carried by fourteen teams.

—At the Toronto assizes on the 20th ult., the court held that there was no negligence on the part of Messrs. Firstbrook Bros. box makers, Toronto, who were sued by Alfred Reid for injuries received while working at a buzz saw.

—Messrs. Perley & Pattee, Mr. J. R. Booth, Messrs. Bronson & Weston, of the Chaudiere, and the Hawkesbury Lumber Co., running Hamiltons old mills at Hawkesbury, have sold their stocks of last year's deals.

—The increased duty on cedar has not affected the cut in the country around Brighton, Ont. As many ties, posts and poles have been taken out this season as in any previous. The weather could not have been better for operating.

—Mr. C. B. Powell, of Perley, Pattee & Powell, Ottawa, has returned from a ten days inspection trip to the firm's shanties, and reports work well advanced, most of the logs banked, and the roadways everywhere soft and bad.

—Mr. J. R. Booth has sold his timber limits surrounding North Bay, covering a territory of about twenty-two miles, to Mr. J. Bourke, Mayor of North Bay. A new saw mill and a sash and door factory are to be built as soon as possible.

—Messrs. McLaren & Co., of Ottawa, will rebuild on the site of their late fire. A portable mill will be used to cut the dimension timber for the new structure, and McClymont & Co's new Edinburgh mill will cut the logs manufactured this winter on the Gatineau limits.

—At a public meeting held at Emsdale, in the Parry Sound district, delegates were appointed to go to Toronto to interview the government for a money grant to build a slide over the portage to connect the waters of Trading and Peninsula lakes.

—Elma township, in the county of Perth, has a few trees standing yet even after an extra large season's cut of logs. The Monkton mill will cut this summer 1,000,000 feet of logs. Baechler's mill on the 16th concession has stocked over 4,000,000 besides a large quantity of lumber and posts. Lang's mill on the Stratford gravel road will saw 300,000 ft. of logs in addition to shingles. Wm. Atteg, of Donegal, has taken out over 800,000 feet of logs, the largest quantity since 1885.

—James A. Sharp, late of Inglewood, has removed his saw mill to Sudbury where he is doing a profitable local trade. The McCormack mill at the same place is turning out about 30,000 feet per day, the output being shipped to Ottawa principally. Ford & Co. are at present erecting a large planing mill and the prospects are that they will do a successful trade. Sudbury is growing rapidly and is likely to boom the present season on account of new and extensive mining enterprises.

## QUEBEC.

—In the lake St. John district the snow has gone and almost all the ice.

—Louis Laudry, Becancour, Que., engaged in the manufacturing of matches, has failed.

—Owing to the depressed state of the lumber market last year, many of the smaller operators were unable to pay their dues and the entire revenue collectable was very small compared with former seasons.

—Tenders for the new Board of Trade building in Montreal will be called for shortly. The estimated cost is between \$275,000 and \$300,000. The property known as the Cuvillier block, on St. Peter street, has been selected as a site.

—A gang of shantymen returned to Ottawa on the 20th ult. from McLaren & Edward's shanties and say the snow is going very fast up the Gatineau. The drive will have to be rushed as early as possible this season.

—A veteran lumberman was buried at Gatineau Point on the 16th ult., in the person of Joe Berthiaume, who for over half a century in his lifetime acted as foreman for the concern of Hamilton Bros. He was ill for nearly two years previous to his death.

## NEW BRUNSWICK.

The C. P. R. and the Furness line of steamers have arranged to carry to the U. K. Ottawa shipments of lumber via St. John, in place of the U. S. route via Portland, Me.

—The Maine Co., who own over 50,000 acres of land on the Keswick, are about to build a pulp mill on the C. P. R., about two miles from Zealand. It is also proposed to erect on the same railroad, at Cardigan, a saw mill and necessary buildings to manufacture fruit boxes, brushes, broom handles, lasts and small hardwood ware.

## BRITISH COLUMBIA.

—A sample car of assorted lumber was shipped from the Royal City planing mills, of New Westminster, to Montreal on the 11th ult.

—All the mills in New Westminster are running.

—The Royal City planing mills, New Westminster, are building ten cars for the railroad at Mud Bay.

—The firm of McGarvey & Johnston, loggers, have a large force of men in the woods opposite Aliceville, taking out piles for the North Pacific Lumber Co.'s new dock.

—Clarence DeBeck, lately of the Brunette saw mills, New Westminster, is at the head of a company who will erect a mill with a capacity of 100,000 feet per day.

—The Provincial museum of British Columbia has been enriched by the gift of a book of samples of native woods from J. B. Kennedy, of the Brunette saw mills, New Westminster.

—At the Brunette saw mills in New Westminster, on the 10th ult., the circular saw crashed through a dynamite cartridge embedded in a log. Some time previous an axeman in trying to split it had carelessly left the charge unexploded. It did not take kindly to the saw's effort and the employees, it can be conjectured, are very well pleased.‡

## MANITOBA.

—G. A. Fisher, of Saltcoats, has opened a lumber yard at Yorkton, with Mr. W. S. Gordon as manager.

—Chevrier & Co. attribute their failure to a loss of \$17,000 invested in the St. Catherines Mill and Lumber Co., who sunk a large sum in the disputed territory of Algoma. When the transfer of the territory was made to the Ontario Government the patents of the Dominion Government became null and void. Chevrier & Co.'s patent was obtained from the Dominion.

## UNITED STATES.

—Austin Corkin's scheme of connecting Montank Point L. I. with Milford Haven, England, has been perfected and practically carried by the United States Congress granting a subsidy. Eight steamships are to be built of 12,000 tons each to carry passengers and light goods. The distance from point to point is 2781 nautical miles, and it is expected to be covered in less than five days.

—Over three thousand years ago a tiny shoot forced its way out of the ground, six thousand feet above the level of the Pacific in Tulare County, California. It gradually worked its way skyward until it reached the height of 312 ft. Its lowest limb was 172 ft. from the ground and its base resembled a huge water tank. After braving the storms and sunshine of thirty centuries, ten woodsmen hacked through it in three weeks, sawed off a section and hauled it thirty miles to the nearest station. Over four hundred ordinary sized trees had to be cut down and much blasting of rock before the brobdignagian block reached civilization. When hollowed, furnished, lighted with electricity and shown as a novelty at the World's Fair in Chicago in '93 the various ejaculations, meditations, remarks and contemplations made by the visitors who gaze upon the shell would form interesting reading if published in book form.

—The inconvenience caused to the tenants by the erection of the annex to the Lumber Exchange of Minneapolis, was of small importance compared with the disadvantages that attended the destruction of it by fire. For years almost the entire lumber brotherhood of the city met within its walls not only for the transaction of general business but the centralization of dealers rendered it the headquarters for sales and purchases. They are now scattered over the city in temporary offices awaiting for a reunion in the new structure.

## HOME AND FOREIGN TRADE REVIEW.

Office of CANADA LUMBERMAN, }  
March 31st, 1891. }

THE leading feature of the trade in March has been the large shipments of lumber going forward by rail to points in the United States. This trade, which is really so much "found" business, has been made possible only by the reduction in United States duties to \$1 per thousand feet, and the special winter rates offered by the G.T.R. From Gravenhurst, Longford, Wau-baushene, Collingwood, Midland and other points there has been a steady stream of shipments, and connections have been opened up with many points both in the east and in the south which Canadian lumber has hitherto been unable to reach. This very considerable movement of lumber during the winter must help to equalize the supply of cars required during the season, and it is to be hoped that the business created has been sufficiently remunerative to be an inducement to the G. T. R. Co. to continue the rate for another season. Without this winter car trade manufacturers and wholesale dealers would have had little to do except financing and praying for better times.

The local trade, both in Toronto and western Ontario, has fallen far below that of last year in the same period. A good many building permits are being announced in the daily papers, but it is to be noted that most of these are for buildings in central localities. Suburban terrace building, the great consumer of lumber, is at a standstill, and is likely to stay so for another season. The population has not yet commenced to overtake the house supply. There are signs of activity around the wharves. Vessels are getting ready for the opening of navigation and lumber is moving down to the docks in anticipation. Freights cannot be said to be settled yet, though a good deal of dickering is going on. Prices are not materially changed and nothing further may be said on this point.

Considerable discussion has resulted from the proposal to appoint a Government Inspector for lumber. The summary of the advantages and disadvantages may be briefly cited as follows. The advantages of a government inspection are that there would be an absolute and final authority to which appeal could be made in cases of dispute, and as between parties dealing with each other by government inspection there would be no room for disagreement. On the other hand objections to a Government Inspector are numerous: (1) Appointments would have to be made by an examining board, as in the case of hides and leather. The trade is so extensive and spread over so much territory that several inspectors would be required. This would mean considerable expense. (2) The qualities and subdivisions of qualities in lumber are so numerous that an Inspector would require a large and very active experience in order to keep posted. (3) The tendency among manufacturers and dealers would be to avoid the expense of an Inspector's fee by agreeing upon the inspection of their own employees. This would permit harmony in the trade but the Inspectors might starve. (4) As trouble would be more likely to arise in connection with exported lumber than any other, how could foreign purchasers be compelled to decide by government Inspector's decisions?

Just as loggers are coming out of the woods, not because the weather compels them to do so but because they have manufactured all the logs they require, when driving and towing will engross their attention, and the hum of the saws will replace the ring of the axes, a general report of the Dominion's doings and intentions in the lumber trade would fill our journal. It is even impossible to treat the subject provincially, and our readers must be content with condensed reports from lumbering centres. At Midland and other Georgian Bay ports, complaints are rife from wage earners, saw mills and workmen in local lumber yards about the undoubted scarcity of work during the summer, owing to the sale of logs in place of sawn lumber to United States' millmen. This was anticipated before logging commenced, but more than one millman who started in to cut for himself has sold the result of his winter's operation in the log.

From Ottawa the reports show a complete clearance of deals, and every mill during the coming season will saw on new orders or fill up their yards on expectation. It is not expected that Mr J. R. Booth's new mill will be running before May the 15th, when the six large band saws will be in position. Logging has ceased in the central Ontario district. From nearly every western village and town comes the report that owing to the exceptionally fine weather and the depletion of local lumber yards requiring stock for their spring trade the quantity of logs cut for home consumption is greatly in excess of the quantity marketed for several years, and many mills that have existed on custom work will once more saw their own cut of logs.

In eastern Canada Messrs. Kingsmill, at Kingsville, N. B. and Messrs. Stetson, Cutler & Co.'s mill at Pleasant Point N. B., the mills of Messrs. Miller & Woodman, A. Cushing & Co., Stetson, Cutler & Co.'s Indian town mill, all in the vicinity of St. John, N. B.,

have commenced running on the remnant of 1890 cuts, the supply being sufficient to keep the saws going until this season's logs reach the mills.

## UNITED STATES

Independent of Buffalo's wholesale trade to outside points her local trade this year in pine is very promising. The number of residential buildings to be erected this summer, as well as business blocks, will exceed last year's. The attempt to adjust the demands of the mill men and dealers on the question of wholesalers' prices, mentioned in our last issue, fell through. At the vessel owners meeting to stay chartering until May 1st or 15th the lumber fleet was not represented. The annual meeting of the Buffalo Lumber Exchange for the election of officers was held on March the 7th, and Albany N. Y. on the 12th. The Hudson River partially cleared of ice during the first week of the month. In anticipation of a total clearing, many dealers who had orders booked to ship the moment boats moved ordered on their stocks only to be disappointed by an ice jam, followed by a freshet which interfered with early shipments. The export trade, more marked in the hardwoods than in the soft varieties, is improving in New York city. Building operations are being pushed as fast as the weather will permit, and trade can be safely said to be fair but far from booming. The older cities such as New York, Boston, Philadelphia and Baltimore, are widening their borders and filling up vacant property with handsome structures. Everything looks favorable for a good volume of trade in the Northern and New England states. Spruce lumber is at present from \$1 to \$2 less than the same date of last year, due to our supplied markets. White pine is being purchased in the usual quantities this season, while yellow pine has a downward tendency.

## FOREIGN.

We went exhaustively into the U. K. trade in our last issue, reviewed it for the year 1890, and gave copious extracts and comments. Since then there have been quite a few sales of timber and deals with no stiffening of prices. The *Timber Trades Journal* advises Canadian shippers of oak timber "To march with the times if they want to make that industry a success and to send it forward in specially sawn sizes. The United States' products in this form, have run the Canadian nearly out of the market."

## AGAINST RECIPROCITY.

Were it to come to a vote not one lumber manufacturer in a hundred in the United States would vote for reciprocity with Canada. The political complexion of the voters would cut no figure. No party line would be drawn in the contest.

In the Saginaw valley, and possibly in some other sections of Michigan, there are a few mill men whose timber is nearly exhausted, and who want Canada logs to keep their mills running, but outside of these the manufacturers would be as a unit against reciprocity.

This opposition would be extremely logical. They believe that, considering the number of American saw mills, the amount of standing timber, and the money invested in their business, they are justly entitled to supply the American market. They do not want to compete with Canadian lumber made from cheaper stumpage than can be found in America, and by mill men and loggers who work year after year for smaller wages than men in like employment obtain on this side of the line. Their can be no exchange that would be beneficial to the American manufacturer; on the other hand, it would be detrimental to him. Canada wants some of our hardwoods but none of our pine. Where she buys in American markets one dollar's worth of lumber she has ten times that amount to sell in those markets. Reciprocity, so far as lumber is concerned, would be only in name.

The farther from the white pine district the stronger is the objection to reciprocity. Every southern lumberman would fight the movement to the bitter end. He knows that every foot of lumber that crosses the Canadian line southward pushes a foot of his product also southward. To suit him there is already enough white pine lumber in the northern markets which he would in part supply.

Opposition to reciprocity on the Pacific coast would also be bitter—possibly more so than in the south. What the Pacific slope manufacturers want to-day is a market. There is a world of timber, and mills are so plentiful that were they to run full capacity, nearly two feet of lumber would be cut where but one could be sold. These men would not welcome to San Fran-

cisco, and the nearer markets of the coast, lumber made in the British possessions.

The fact is, American lumber manufacturers in a most emphatic manner want the American markets for American lumber.—*Northwestern Lumberman.*

## CORRESPONDENCE.

VANCOUVER, B.C., March 20th, 1891.

Editor Canada Lumberman.

DEAR SIR,—Your British Columbia correspondent, H. G. R., evidently does not calculate for himself the value of figures, either by themselves or in their relation to each other, before committing them to paper and through your columns to your readers, or he never would have published such a mass of bosh as he did in your March issue about Hastings mill.

This mill (poor old moss back that she was before the new firm got hold of it) never in its best days cut anything near 30 millions in one year, and it is doubtful if this amount has ever been reached by any mill in B. C., except once by the Moodyville mill three years ago or so. The 35 millions your correspondent credits the Royal City Planing Mills Co. with ought to have been put down as the cut of their three mills, for no one of them running day and night all the year round could do it.

To return to Hastings mill, your correspondent, not content with exaggerating the amount of the output, (by itself a magnificent stretch of imagination,) he strives to out-do even that by the value he gives it, viz. \$1,750,000, which for 30 millions of Fir lumber is a price big enough to unsettle the brains of any millman who is not fortunate enough to own stock in such a bonanza as Hastings mill must be. Fancy \$58.33 per M for lumber and logs. The very thought of the sum of a million and a half of dollars for milling 30 million feet of logs is enough to cause even the most conscientious of christians to make a bad rupture of the tenth commandment just as soon as its magnitude was realized, and as often as the thought of it entered his head. Not satisfied yet, but apparently burning with a desire to furnish your readers with information, no matter whether valuable or not, he proceeds to itemize his little account as follows:

Rough lumber.....	13,059,000
Dressed " .....	955,000
Total.....	14,014,000

besides a few laths and pickets.

Great Caesar! There's nearly sixteen millions gone already! But where did they go and who got them? Apparently, however, the disappearance of over 50 per cent. of his original amount does not seem to have daunted him in the least; perhaps he never missed them, so he proceeds to again itemize what he has left with the following effect, viz:

Lumber shipped, foreign } .....	2,243,000
rough and dressed }	
Lumber by rail.....	430,000
Home consumption.....	2,341,000
Total.....	5,014,000

out of the grand array of 30 millions which he marshalled for our gaze at the out-set, his figures dwindle down to a little over 5,000,000. It is a matter of regret that the talented compiler of the item in question has been precluded from following the lumber any further than he has done, for not only are we, (your readers) deprived of a magnificent lesson in reduction *ad infinitum*, but the gap which the entire disappearance of the 30 millions would have caused would not but have the effect of bettering the lumber trade on this coast at least.

I enclose my name, not for publication. A glance at a B. C. directory will show it there.

I have the honor to be

Yours truly,  
A. P.

IN Hanover, Germany, a plan is conducted worthy of imitation by the patrons of industry in Canada who have during their winter meetings given considerable attention to forest preservation and tree planting. Municipalities, and even individuals, who are inclined to establish forest grounds receive loans at 2 per cent. interest, and even cheaper, from the provincial Government, to be reimbursed yearly by small instalments. The provincial Government also employs vagrants and criminals in forest culture. Within the years 1876 to 1878 they planted 9,000 acres by this means.

### THE "DEFIANCE" PLANER, MATCHER AND MOULDER.

THE Cant Bros. Co., (Ltd.) of Galt, are the builders of the "Defiance" Planer, Matcher and Moulder shown herewith. This machine is of new and improved design, and can be used for rapid matching, surfacing or fine panel work on either hard or soft wood. The feed rolls are 4 inches in diameter, and all are driven by heavy gearing, thus ensuring a sure and reliable feed. The cylinder and side head spindles are made of the best machinery steel. "Shimer" matcher heads are supplied with this machine. It will plane 24 inches wide, and from 1-16 to 7 inches thick, and will match 12 inches wide. There is also a moulding attachment with a 7 inch brass slotted head and adjustable heads.

This company have also just brought out a new double rip and cut-off saw, which is specially designed for cutting to accurate uniform lengths all kinds of material used in furniture factories, etc. It has two tables, each four feet in length, which can be rapidly adjusted to suit any length of material from eight inches up to 6 ft. 6 in. long; after which the operator can cut off both ends of the material at one operation absolutely square. The tables, which are of iron, remain level but the arbors carrying the saws can be raised or lowered by means of a hand wheel. The machine has a sliding cross-cut guage which can be readily adjusted for different lengths, and which can be instantly removed or replaced. One table has a ripping guage which can be bevelled to varying angles. No sliding carriages are necessary as the arrangement of the guages is such that one operator can work with a ripping saw and the other can cut both ends off the material at once, any length from 22 inches to 5 feet.

### FELLING FIR TREES.

AN Eastern man, who has within a few years started a saw mill in Oregon, gives the following as his way of felling fir trees: "We are on the mountains, and use cattle for logging. The timber is all around us, and is very fine. Some of our tall timber will measure 6 to 12 feet in diameter, and run up to 300 feet. The way we get them down, perhaps, will be interesting to some of your readers. When a tree is too large to saw down, we bore an inch auger hole straight into the body of the tree about 2 feet from the ground 18 to 24 inches deep, then we bore another hole about 20 inches in a line above, and let the auger range down so as to strike the inner end of the first hole bored. The points where they join must be near to the centre of the trees. Then we put in some maple coals that are aglow with heat, and they fall down to the junction of the two holes. Then we blow them into a blaze with a hand-bellows, and our work is done. They will come down themselves, and once down the fire goes out. The upper hole forms a stove pipe and the lower hole forms the draft. Trees up to 6 feet in diameter we saw down. We cut a small notch, say from 8 to 10 inches deep, so it will be square; then we take a 7 foot cross-cut saw, and go to the opposite side and saw straight into the notch; we follow up with iron wedges to keep the tree from going back until we saw clear through, lacking three or four inches. Then it comes down and does not spoil your timber."

### A SUNKEN FOREST.

THERE is a sunken forest of white cedar in New Jersey which has been continuously "mined" for its valuable timber for over eighty years. The curious industry

of digging for the sunken logs has been carried on by the people of Dennisville, Cape May county, a village which was brought into existence solely through the wealth of the buried timber in its vicinity. Over the sunken forest, trees of large size are growing, and in many instances these are cut away in order to get at the more valuable timber, which lies only 3 or 4 feet below the surface. The exact age in which they lived is a matter of curious conjecture. It is probable that they were buried many centuries ago by the action of an earthquake.

### THE CARRYING TRADE.

IT should be distinctly borne in mind in considering the carrying question that the lake rates effect charges generally, whether the freight is carried by vessel or rail. We have referred to the necessity for open free waterways of not less than 20 feet draught to keep down rates, and now proceed to consider the projected plans.

Beginning at the south-east end of lake Michigan it is proposed to cut a ship canal to Toledo from near Michigan City, a distance of 160 miles, at an estimated cost of \$138,405,432. There would be 65 locks and 19 railway crossings. This immense expenditure would chiefly accommodate Chicago, as it is not likely that any of the Milwaukee ships would pass through it, as they would have slack water by way of the straits of Mackinac, and the increased distance would only be about 250 miles, and the time required to pass the canal would greatly exceed the time necessary to pass through the straits. Chicago, as well as Milwaukee, had bette-

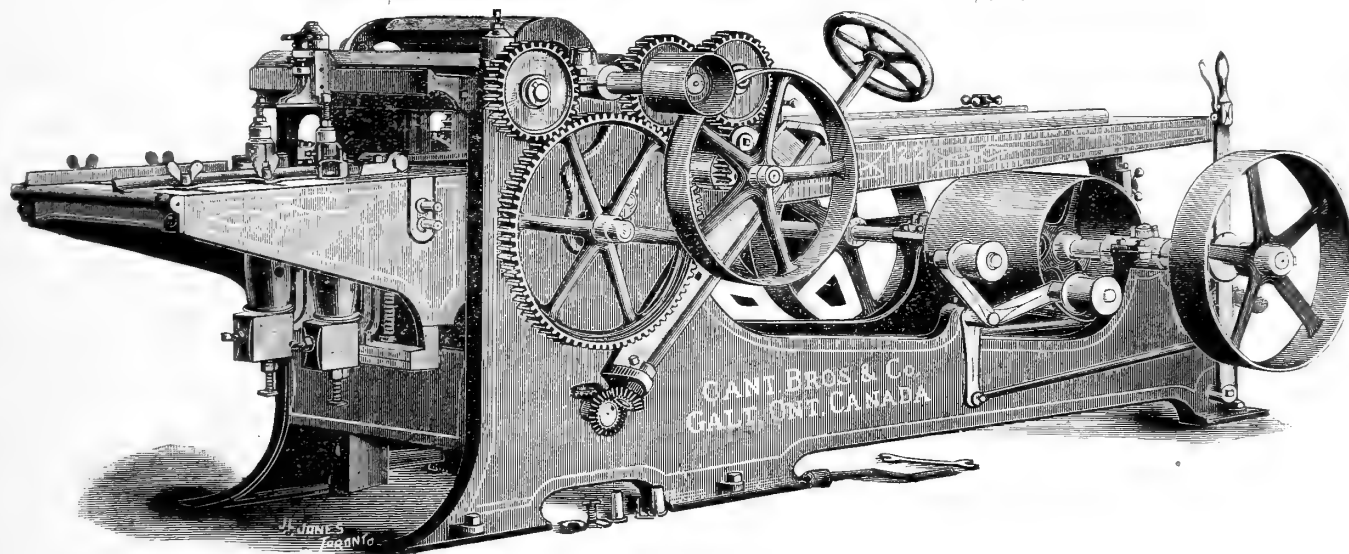

"DEFIANCE" PLANER, MATCHER AND MOULDER.

pass by the straits. This canal will never be constructed. It was contemplated, if the canal were completed, to run to Buffalo through lake Erie, and then to pass as now to New York or into lake Ontario. To enlarge the Erie canal to 20 feet of water, the same capacity as the projected Peninsula Canal, would cost not less than \$250,000,000. A ship railroad has also been projected across the peninsula at a cost of about \$40,000,000. This too would be chiefly for the Chicago trade—certainly none of the vessels in the northern part of lake Michigan bound east would go by it. Then to bring the freight into lake Ontario a canal on the United States side of the Niagara river would cost \$35,000,000, or a ship railway about \$11,000,000. If canals were cut the cost would be about \$173,000,000. If ship railways were built the cost would be over \$50,000,000, \$40,000,000 of which would be of no service to any of the lake ports except Chicago. Proceeding northward the next route is that used at the present time—lake Michigan through the straits of Mackinac down lake Huron, the river and lake St. Clair, through lake Erie, and as before onward to the east. In this case the chief expense would be enlarging the Welland canal, at a cost of not less than \$25,000,000, besides the constant labor and expense of keeping the channel open on the St. Clair flats. The chief objections to this route are the long distances and intricate navigation. To lessen the distance and avoid the intricate navigation there was formerly projected the Georgian Bay canal. It was to leave lake Ontario, pass up the Humber, cross the ridges to the Holland marsh, through lake Simcoe to

Barrie, then to the Nottawa-aga river and down it to the Georgian Bay, at a cost of about \$25,000,000. It is now proposed to construct a ship railway directly from Toronto to the Georgian Bay at a cost of about \$15,500,000. The road at the above cost would have a carrying capacity of not less than 8,000,000 tons during the season. Vessels of a gross weight, with their cargoes of 5,000 tons, would be lifted from the water and carried across from the mouth of the Nottawasaga river to the mouth of the Humber, 66 miles in ten hours.

The last work contemplated and still advocated is the Ottawa valley canal. Leaving the St. Lawrence at Lachine this canal would proceed up the Ottawa river to the Mattawa, up that river to Trout lake, across the water shed into lake Nipissing, and down the French river to Georgian Bay. This route was surveyed by Walter Shanly and T. C. Clarke. Both of these eminent engineers contemplated raising lake Nipissing to the level of Trout lake, 23 feet. This could not now be done on account of the towns, villages and settlements on its shores, and a new survey would be required to enable fairly approximate estimates to be made out. To make the necessary cut between Trout lake and lake Nipissing would cost for the five miles of granite rock cutting about \$20,000,000. An estimate on the imperfect data available places the cost of this work at \$83,000,000. It would seem then on a careful examination of the whole subject that the construction of the Hurontario Ship Railway would better meet all the required conditions of the carrying trade than any of the other projected schemes above referred to. It would cost

much less: greatly shorten the distance: reduce by days the period of transit: carry much cheaper, and afford a connecting link between the trade of all the great lakes. We need hardly say that if this work were constructed it would give an immense impetus to the commercial and general importance of Ontario's metro-

poli.—*Canadian Miller.*

### TO REMEDY SWAYING AND OSCILLATION.

FREQUENTLY the oscillations of the main belt in a mill come in unison with the beat of the engine, and a pretty perceptible slapping about of the belt is noticeable, says the *Artisan*. The beat of an engine will often come in sympathy with the rhythmic sway of of the building, and so increase it as to be very perceptible. If this were continually going on in exact time it would become so great in time as to be dangerous; but one or the other gets ahead and mixes the movement, so that it gradually ceases until they are again in unison. If the speed of the engine is changed in either case the swaying will be kept mixed all the time instead of occasionally. On long lines of shafting this will appear also, the pull on the belt at the commencement of the stroke being in unison with the spring of the shaft, thus causing a marked oscillation. The same remedy is applied here, to mix the two movements purposely, and the trouble is partly removed, if not entirely.

### PINE-TREE SOAP.

AN American inventor has brought out a process for making soap from the resinous matter in the needles of the pine tree. The resin is extracted by means of alkali, and the woody fibre is removed from the product, which, on condition of fat, yields an ordinary soap containing resinous and fatty acids.

—Mr. R. Crawford, of Oro Centre, has commenced the manufacture of shingles.



TRADE REVIEW.

Toronto, Ont.

TORONTO, Mar. 28, 1891.

CAR OR CARGO LOTS.

Table listing lumber prices in Toronto, Ontario, including items like 1 & 1 1/2 in. cut up and better, 1x10 & 12 dressing and better, etc.

YARD QUOTATIONS.

Table listing yard quotations for various lumber types and sizes, such as Mill cull boards & scantling, Shipping cull boards, etc.

Hamilton, Ont.

HAMILTON, Mar. 26, 1891.

Table listing lumber prices in Hamilton, Ontario, including Mill cull boards and scantlings, Shipping cull boards, etc.

Ottawa, Ont.

OTTAWA, Mar. 28, 1891.

Table listing lumber prices in Ottawa, Ontario, including Pine, 1st qual., 2nd, etc.

Montreal, Que.

MONTREAL, Mar. 28, 1891.

Table listing lumber prices in Montreal, Quebec, including Pine, 1st qual., 2nd, etc.

St. John, N. B.

ST. JOHN, Feb. 24, 1891.

Table listing lumber prices in St. John, New Brunswick, including Deals, Boards, Scantling, etc.

Vancouver and New Westminster, B.C.

NEW WESTMINSTER, Feb. 17, 1891.

Table listing lumber prices in Vancouver and New Westminster, British Columbia, including Car load and ship rates, Wharf Plank and Timber, etc.

Albany, N. Y.

ALBANY, N. Y., Mar. 28, 1891.

Table listing lumber prices in Albany, New York, including Boards, 1x10 in. each, Joist 4x6, etc.

Buffalo and Tonawanda, N. Y.

BUFFALO, Mar. 26, 1891.

Table listing lumber prices in Buffalo and Tonawanda, New York, including Clear, 1 in. & clear, Dressing, 1 to 2 in., etc.

Saginaw, Mich.

EAST SAGINAW, Mar. 28, 1891.

Table listing lumber prices in Saginaw, Michigan, including CARGO LOTS, YARD QUOTATIONS CAR LOTS DRY, etc.

New York City

NEW YORK, Mar. 17, 1891.

Table listing lumber prices in New York City, including Black Walnut, Poplar, or White Wood, Cherry, etc.

Boston, Mass.

BOSTON, Mar. 28, 1891.

Table listing lumber prices in Boston, Massachusetts, including Western Pine—by car load, Eastern Pine—Cargo or Car Load, etc.

Oswego, N. Y.

OSWEGO, Mar. 28, 1891.

Table listing lumber prices in Oswego, New York, including Three uppers, 1 1/2, 1 1/2 & 2 inch, etc.

**A. M. DODGE & CO.**  
 MANUFACTURERS of and Wholesale dealers in all kinds of Lumber, Lath and Shingles. Tonawanda, N. Y.

**COWPER & GREGORY.**  
 RECEIVERS and Forwarders of Lumber, Lath, Shingles, &c. Unexcelled facilities for shipping by canal or rail. Tonawanda, N. Y.

**CHEESMAN DODGE**  
 TIMBER and Lumber Merchants. Ship and Boat stock, Railroad Ties, &c. Office, 16 West Seneca Street, Buffalo.

**EMMET FLEMING**  
 INSPECTOR and Commission dealer in Lumber. Office, 257 Louisiana Street, Buffalo, N. Y.

**LAYCOCK LUMBER CO.**  
 MANUFACTURERS of Pine, Hemlock and Oak Timber up to 35 feet in length. Saw Mills: Ackley, Pa., Black Rock, N. Y., Gravenhurst, Ont. Office, corner Main and Seneca Sts, Buffalo, N. Y.

**J. & T. CHARLTON**  
 WHOLESALE dealers in Masts and Spars, Canada Round Pine, &c. Tonawanda, N. Y.

**WILLARD W. BROWN.**  
 202 Main Street, Buffalo, handles all kinds of Hard Woods.

**A. P. & W. E. KELLEY CO.**  
 WHOLESALE Lumber dealers. Yards at Tonawanda and Chicago. Correspondence invited.

**C. P. HAZARD.**  
 WHOLESALE dealer in Lumber, Shingles, Lath and Fence Posts. Correspondence invited from the Canadian trade. No 92 River Street, Buffalo, N. Y.

**L. A. KELSEY LUMBER CO., (Ltd.)**  
 MANUFACTURERS and dealers in Hardwood Lumber of all kinds. Describe stock and write for prices. Office Tonawanda, N. Y.

**BOVEE & HOWDEN**  
 MANUFACTURERS and Wholesale dealers in Hard and Soft Wood Lumber. Holders of Canadian stocks are invited to write for quotations. Offices at Tonawanda and Le Roy, N. Y.

**THE TONAWANDA LUMBER CO.**  
 MILLS at East Tawas, Mich.; office 106 Main Street, opposite N. Y. C. and H. R. R. Station, North Tonawanda, N. Y.

**Cash for Lumber**

**W. N. McEachren & Co.**  
 Wholesale dealers in all kinds of

**HARDWOOD LUMBER**

**NO. 3 DOCK  
 TORONTO**

WRITE US FOR PRICES AND SIZES TO CUT.

WE PAY CASH WHEN LOADED ON CARS.

HERBERT G. ROSS. Box 273. REGINALD C. BLAKER.

**N. G. ROSS & CO.**  
 Real Estate, Fire and Life Insurance, Shipping and General Commission Agents.

Timber Limits and Farming Lands a Specialty.  
 A.B.C. Code, Cable address, "Ross."

**NEW WESTMINSTER, - - B. C.**  
 CORRESPONDENCE SOLICITED.

**LUMBER  
 TRUCK \* WHEELS.**

\*\*\*\*\*  
**The Montreal \*  
 \* Car Wheel Co.**

MANUFACTURERS OF  
**CHARCOAL IRON CHILLED  
 RAILROAD WHEELS**

Offices: New York Life Insurance Building, Montreal.

Works: Lachine, Quebec.

\*\*\*\*\*

WE make a Specialty of Wheels suitable for the requirements of Lumbermen and Street Car Service, and can supply them Bored, Finished and Balanced.

CORRESPONDENCE SOLICITED



**THE MONARCH BOILER  
 (PATENTED) AND HERCULES ENGINE.**



Guaranteed to Saw Lumber Perfectly Smooth and Even in thickness.  
 Portable from 6 to 70 horse power. Surpass portable steam power heretofore produced for strength, durability, compactness, and the ease with which they can be moved.  
 The 70 horse power can be taken over the roughest roads, or into the forest, and set up as easily and quickly as an ordinary 20 horse power portable engine, and as firm as a brick-set stationary engine. Engines and boilers of every size and description. Rotary Saw Mills, Shingle and Lath machines, Law Grinders, Planers, etc. Mill machinery and supplies of every description. Every boiler insured against explosion by the Boiler Insurance & Inspection Co. of Canada. Write for circulars.  
 A. ROBB & SONS, Amherst Foundry and Machine works, Amherst, N.S.  
 ESTABLISHED OVER 40 YEARS.

DALTON McCARTHY, President. A. ECKARDT, Secretary. JOHN MCGREGOR, Manager.

**Toronto and Midland Mf'g Co.**  
 (INCORPORATED.)

**Wholesale \* Lumber \* Dealers**

AND MANUFACTURERS OF  
**DRESSED LUMBER, FLOORING**

Ceiling, Sheeting, Siding, Shelving, Mouldings of all Descriptions  
 Office and Yard:

**FOOT OF SPADINA AVE., - TORONTO.**  
 Planing Mills: MIDLAND, ONT.

**PORTER, ROBERTSON & CO.**

STOCKS	WHOLESALE	HARDWOODS
STRIPS	<b>LUMBER</b>	HEMLOCK
SIDINGS		SHINGLES
BILLSTUFF	DEALERS	LATH, ETC.

*Millichamp's Buildings,*

**35 \* Adelaide \* Street \* East,  
 TORONTO.**  
 YARD: NORTHERN DOCK, FOOT OF BATHURST STREET.

**NAPANEE CEMENT COMPANY**  
 (LIMITED.)  
 - MANUFACTURERS OF -

**Hydraulic Cement**

PARTICULARLY adapted for Dams, Smoke Stacks, Foundations, Culverts, Cisterns, Cellars, etc.  
 ENDORSED BY LEADING RAILWAYS AND CONTRACTORS.

**ROACH \* LIME,**  
 For Building, Plastering, Gas Purifying, Paper Making, &c.

**THE RATHBUN COMP'Y,**  
 DESERONTO, ONT.,  
 MANUFACTURERS OF

**\*TERRA\*COTTA\*FIRE-PROOFING\***  
 For Use in Old and New Buildings.

Endorsed by Leading Architects. Absolutely Fire-proof. About as Cheap as Wood or Brick. Weight One-Third that of Brick. Does not Crack on application of Heat or Water.  
 Deadens Noise. Gives Warmth in Winter; Coolness in Summer.

**Galt \* Machine \* Knife \* Works.**



**MACHINE KNIVES**  
 OF EVERY DESCRIPTION FOR  
 Planing, Moulding & Stave Cutting.  
 SEND FOR PRICE LIST  
**PETER HAY, - - - GALT, ONT.**

## TRADE NOTES.

The Cant Bros. Co., of Galt, have just put on the market a new double rip and cut off saw, designed to cut accurate uniform lengths of lumber used by furniture and cabinet factories.

The latest pamphlet issued by J. L. Goodhue & Co., Danville, Que., gives some interesting information on the relative values of rubber, canvas, and leather belting and of the merits and demands of oak tanned and hemlock tanned leather. Besides instructive information on the use of belting there is added a telegraph cipher code and other features.

MR. CARL GARTNER of the American Lumber Yards, Hamburg, Germany, writes us under date of Feb. 10th stating that he is open for any quantity of Canadian red birch in boards 1 in., 1 1/4 in., 1 1/2 in., 2 in., 2 1/2 in., and 3 in. of usual lengths or to be cut to special lengths on order. He wants to know if this stuff can be procured at all from Canada and to whom could he apply. Millmen will please make a note of this.

Messrs. Robin & Sadler, leather belting manufacturers, of Montreal and Toronto, are amongst the Canadian exhibitors at Kingston, Jamaica. The Toronto Branch at the Industrial yearly holds its own with competitors in quality, variety and display. The head office attends to the exhibits at the Dominion exhibition, and in this case made a special effort to secure foreign trade with the West Indies. Their space is filled with samples, embracing the largest of drivers to rolls of inch belting used for straw carriers on threshing machines, in addition to dynamo belts made by their new process. The local papers speak highly of the goods, and in several instances sample orders have been secured.

An article that every user speaks well of must be worthy of commendation. We have on several occasions referred to such an article in these columns and strongly recommended the same to all users of machinery. We refer to Spooner's "Copperine," undoubtedly one of the best babbit metals on the market. It has been used by the best practical men, in the largest shops, and on the finest machinery in the Dominion, and in no instance has it proved a failure. It is a high class metal at a moderate price; a time saver; an economizer of oil; and a saving medium in the wearing parts of machinery. Mr. A. W. Spooner, of Port Hope, Ont., is the patentee and sole manufacturer, to whom all communications should be addressed.

The Dodge Wood Split Pulley Co. advise us of a steadily increasing demand for their pulley from all branches of power users throughout the Dominion. They have lately filled large orders from Northern Pacific R'y Co.'s shops, Winnipeg; Berlin Piano Co., Berlin, Ont.; Boynton Wall Plaster & Cement Co., Kingston; Toronto Electric Light Co., Toronto; Ross & Taylor, Exeter; St. John Gas and Electric Light Co., St. John, N.B.; R. Thackray, Ottawa; Jencks Machine

Co. Sherbrooke, &c. They invite all users of power, mill men, etc., who have not yet investigated the merits of this pulley to do so without cost to themselves, as they furnish any pulley for thirty days trial, and if not satisfactory to be returned without charge. They mail free on application, a handsome illustrated catalogue and price list, and solicit correspondence.

## PERSONAL.

W. F. Vanstone, flour and saw mill owner, is leaving Brussels and will remove to Manitoba.

Mr. Wm. Foster, sr., father of Wm. Foster, jr., lumber merchant, of Owen Sound, died at the ripe age of 83.

Mr. Beckett, of the London, England, firm of Dobell, Beckett & Co., left Quebec for England the first week in March.

Mr. Wm. Niebergall, of Dunlop, Ont., manager for the last seven years of his father's saw mill, has gone to British Columbia.

Dugald Neil McMillan, lumber merchant, Morden, Man., was recently married to Miss Mary Augusta McKenzie, daughter of Rev. Mr. McKenzie, of Morden.

Mr. C. H. Davison, of the lumber firm of E. D. Davison & Sons, Bridgewater, N.S., is visiting the Pacific coast in both Washington Territory and British Columbia.

Mr. Alex. Pope, of Quebec, an old employee of Messrs. Hamilton Bros., Hawkesbury, Ont., and representing Messrs. Bryant, Pöwis & Bryant, London, Eng., died March 9th in New York.

At the Metropole, London, Eng., were registered on the 7th of March, Mr. John Staples, Mr. A. Staples, Mr. Edson Fitch, Mr. Stewart Dunn and Mr. Harold Kennedy, all lumber merchants of Quebec.

Mr. Malcolm McCaskill, head foreman in the Royal City planing mills, New Westminster, B.C., fell off the steamer Stella on the 10th of March, unnoticed, and almost lost his life from the involuntary and dangerous bath.

## FIRES AND CASUALTIES.

Geo. Laconabe was killed at the Snow Road, north of Kingston, on the 10th ult., while skidding logs.

H. Mack, Jno. Thieme and J. Miller, three loggers, were upset in Alert Bay, B.C., and rescued after being almost chilled to death.

Walter Lewis, employed in Dewar's stove and saw mill, at Kingscourt, near Watford, Ont., cut his throat with a pen knife on the 18th ult.

A workman named James Hovey, in the employ of Mr. Gibson, of Marysville, N.B., while skidding logs into the Nashwaak, was overtaken by one and horribly crushed.

David Robert, a young man working at the shanties of Mr. Francois Marcoux, on the Montmorency, sustained internal injuries by being thrown beneath a number of logs.

Isaac Cameron, son of William Cameron, of Mt. Forest, Ont., was working in the lumber woods in Wisconsin and was struck by a log while unloading a car and instantly killed. The remains were brought home.

Injured by falling trees or limbs during March: J. Anderson, working in J. Johnston's shanty, near Young's Point, Ont.; Albert Kisson, Coulson, Ont.; Earnest Eagle, of Perry, Muskoka; J. Rose, Matilda, Ont.

The following received lacerated fingers during March: Geo. Ruby, of Dashwood, Ont., working in Cook's saw mill; J. Young, of Dashwood, Ont.; Geo. Bourrette, of Morrisburg, Ont.; Alfred Moss, Deseronto, Ont.; R. Emerson, of Manitou, Man.; Alex. Thompson, Stanley, Ont.

Amongst the fatalities for the month are: J. Demers, killed in Bronson's shanty on the Petewawa; Eli. Bogrand, killed in Ainslie's mill, near Staples, Ont., from being entangled in a belt; John Ireland, of South Dorchester, in the County of Elgin, killed by a falling tree; Geo. Disch, 14 years of age, killed in Walkerton, in Kerr & Harcourt's bobbin factory; M. Anderson, Shelburne, impaled by a pointed limb.

VISITORS from the mother country, or emigrants who are conversant with the manner in which timber changes first hands, both in the shape of local standing trees or in imported cargoes of logs or deals, are struck with the different methods employed in the United Kingdom to those in vogue in Canada or the United States. A comparison might be drawn of the two distinct plans, showing advantages in both as well as disadvantages. We reproduce in another column a description of a Liverpool lumber auction sale. The average Canadian, versed in our millmen's disposition of timber, would be very apt to wonder as much at the kind of sale as his cousin wonders when he is introduced for the first time to the plans adopted in Canada.

—D. J. Spaulding, a leading lumberman of Black River Falls, Wis., U. S., has failed liabilities \$210,000; assets \$700,000.

## WANTED AND FOR SALE.

Advertisements will be inserted in this department at the rate of 15 cents per line each insertion. When four or more consecutive insertions are ordered a discount of 25 per cent. will be allowed. This notice shows the width of the line, and is set in Nonpareil type. Advertisements must be received not later than the 27th of each month to insure insertion in the following issue.

HARDWOOD lumber, bought, sold or received on consignment, TUCKER DAVID, lumber commission merchant, 202 Eleventh Ave., N.Y.

## WANTED—TO BUY.

GOOD Canadian Timber Limits and Georgian Bay saw logs. Address, BEN BIRDSALL, Whitney Building, Detroit, Mich.

## FOR SALE.

PAIR TWIN ENGINES, 6x6, with link motion, suitable for rope feed, in order, J. HADDEN, Foxmead Ont.

## WANTED IN 1891.

ANY QUANTITY OF CEDAR TELEGRAPH POLES at shipping points. Terms cash. Apply to J. HARRISON HARVEY, Cobocok, Ont., purchaser for H. D. McCAFFREY, Engineer and Contractor of Telegraph lines, Oswego, N.Y.

## RAILS AND CARS FOR SALE.

Light Steel Rails for Tramways; good order. Cars for lumber, cheap.

JOHN J. GARTSHORE,

49 Front St. West,  
Toronto.

## WANTED.

QUEBEC BIRCH—Those who can furnish choice lumber are invited to correspond with  
JOHN S. MASON & CO.  
240 Eleventh Avenue,  
New York City.

PARTNERSHIP WANTED in paying wholesale or manufacturing business. Advertiser has large experience; will invest three to five thousand dollars cash. Only parties of strictest integrity need answer. "SASH," care CANADA LUMBERMAN.

EMPLOYMENT WANTED by an experienced Lumber Inspector and shipper, acquainted with American and English markets. Can bring small but increasing business. References produced on application. Address, H. M. W., LUMBERMAN office.

## WANTED.

A thoroughly competent

## BAND SAWYER

Who can file, fit, braze and care for saws and take first class care of a band saw mill.

Address, with copy of references and salary required.

THE RATHBUN COMPANY,  
Deseronto, Ont.

## T. SHORTISS,

DEALER IN

## PNE &amp; MINERAL LANDS

9 Toronto Street,  
TORONTO, ONT.

CORRESPONDENCE SOLICITED.

## WILLIAM FOSTER

Lumber & Commission Merchant

Receiver and forwarder of

LUMBER, LATH & SANGLES

OWEN SOUND, ONT.

## A. E. Ames &amp; Co.

Lumber Commission Correspondence solicited from Canadian manufacturers.

Room 3, Lumber Exchange, Chicago, Ill.

TIMBER \* LANDS  
FOR SALE

5000 Acres of Timber  
Lands on the Manitoulin  
Island,

Patented and unpatented, are offered at the

Low Price of

**\$5.00 PER ACRE.**

Some of the lots have timber on them worth \$20 per acre, and the land is of fair quality for farming when cleared.

The Dominion Government having recently taken off the Export Duty on Telegraph Poles, Railway Ties, Shingle Bolts and Saw Logs, the value of the timber on the Island is doubled, owing to its great facilities for shipment to Detroit, Chicago, Toledo, Buffalo, Cleveland and all Lake ports.

The late owners, Messrs. Wm. and Robert Henry, are both deceased, and there being no one to carry on their business, these lands will be sold low, in block to close out the estate. Tenders solicited and purchases liberally dealt with. All necessary information can be obtained from the trustee and Solicitors,

Messrs. FRANCIS & WARDROP,  
Barristers, &c.,

JAMES McGEE, Trustee, Toronto.

J. J. TURNER,  
Sail, Tent and Awning Maker.

251 GEORGE AND 154 KING STREETS,  
PETERBOROUGH.

Canoe, Yacht and Boat Sails made to order.  
Perfect Fits guaranteed.

Every description of Lumbermen's Subblies  
and Waterproof Clothing.

CHICAGO, MILWAUKEE AND ST.  
PAUL RAILWAY.

Electric Lighted and Steam Heated Vestibuled  
Trains, with Westinghouse Air Signals, between  
Chicago, St. Paul and Minneapolis, daily.

Electric Lighted and Steam Heated Vestibuled  
Trains between Chicago, Council Bluffs and  
Omaha, daily.

Through Vestibuled Sleeping cars, daily, between  
Chicago, Butte, Tacoma, Seattle, and Portland,  
Oregon.

Solid Trains between Chicago and principal points  
in Northern Wisconsin and the Peninsula of  
Michigan.

Daily Trains between St. Paul, Minneapolis and  
Kansas City via the Hedrick Route.

Through S. Sleeping Cars, daily, between St. Louis,  
St. Paul and Minneapolis.

The finest Dining Cars in the World.

The best Sleeping cars. Electric Reading Lamps  
in Berths

6,100 miles of road in Illinois, Wisconsin, North-  
ern Michigan, Iowa, Minnesota, Missouri, South  
Dakota and North Dakota.

Everything First-Class.

First-Class People patronize First-Class Lines.

Ticket Agents everywhere sell Tickets over the  
Chicago, Milwaukee and St. Paul Railway.





A. ALLAN, Pres.

J. O. GRAVEL, Sec-Treas.

F. SCHOLLES, Man. Director

# Canadian Rubber Company

## OF MONTREAL.

SOLE AGENTS AND MANUFACTURERS  
OF THE

### Forsyth (Boston Belting Co.,) Patent Seamless **RUBBER BELTING**

For the Dominion of Canada



----- Capital \$2,000,000. -----

Our Rubber Belting is Unequaled in America.

All kinds of Rubber Packings, Rubber Engine, Hydrant, Suction, Steam, Brewers' and Fire Hose; Rubber Valves, Car Springs, &c., &c.

*Mould Goods of Every Description.*

Superior Quality Rubber Goods.

Head Office and Factory, Montreal, J. J. McGILL, Manager.

Western Branch, Corner Yonge and Front Sts., Toronto, J. H. WALKER, Manager.

## The Casselman Lumber Co.

CASSELMAN, ONT. Successors to FLATT & BRADLEY.

ESPECIAL GOOD FACILITIES FOR SHIPPING.  
HEMLOCK BILL STUFF OF EXCELLENT QUALITY.

ALSO MANUFACTURERS OF  
PINE, SPRUCE, ASH, MAPLE AND OTHER HARDWOODS.  
CORRESPONDENCE SOLICITED.

J. W. MAITLAND  
H. RIXON

J. G. AINSLIE  
W. STODART

## Maitland, Rixon & Co.,

Owen Sound, Ont.

### Saw Millers and Lumber Dealers

All kinds of Building Material kept in stock.

WE MAKE A SPECIALTY OF  
LONG BILL STUFF IN ROCK ELM, PINE, CEDAR AND HEMLOCK  
QUOTATIONS FURNISHED ON APPLICATION.

GEO. HASTINGS.

JOHN GRAY.

H. HANCOCK.

## GEO. HASTINGS & CO.

### Lumber Merchants

TRUST BUILDING CHAMBERS,  
Cor. Yonge and Colborne Streets.

TORONTO.

All Kinds of Pine and Hardwood Lumber.

BILL STUFF CUT TO ORDER A SPECIALTY.

## DONOGH & OLIVER,

Wholesale Dealers in

# LUMBER

OFFICE:

Nos. 213, 214 and 215, Board of Trade Building,

COR. YONGE AND FRONT STS.

TORONTO, ONT.

## THE "LEADER"

The Finest Tempered, Fastest Cutting  
and Best Saw made on the Continent.



Manufactured of Triple Refined Silver Steel,  
Rolled specially for us from Superior Ingots.

### THE KING OF CROSS-CUT SAWS.

## R. H. SMITH COMPANY, LTD., ST. CATHARINES, ONT.

Sole Manufacturers.

The Gold Medal,  
Toronto, 1883

# WOOD WORKING MACHINERY

The Gold Medal,  
London, 1883

## For Door, Sash, Blind and Furniture Factories

PLANERS.

MOULDERS.

TENONERS.

SHAPERS.

RIP SAWS.

SAND PAPERERS.

BAND SAWS.

BAND RE-SAWS.

PANEL RAISERS.

DOVETAILERS.

JOINTERS.

DOUBLE SPINDLE BORER.

BUZZ PLANERS.

MORTICERS.

BLIND MACHINERY.

BAND SAW FILER.

BAND SAW SETTER.

ETC., ETC.

# The Galt Bros. Co., Limited,

## GALT, ONTARIO.

Write for Circulars  
and Prices

Correspondence  
Solicited.

# Rhodes' Improved Swage for Circular and Gang Saws.

PATENTED JULY 2, 1889

THE MOST PERFECT MACHINE FOR THE PURPOSE EVER INTRODUCED.

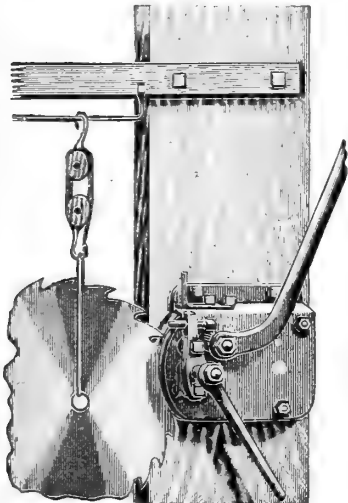

SWAGE IN OPERATION.

It will swage the hardest as well as the softest saws. Never pulls the points of the teeth off, as the swaging is done by direct and steady pressure, and not by rolling pressure.

Swaging done with this machine will stand longer than when swaged with any other machine or by hand.

It makes the swage the heaviest on the under side of the tooth, and leaves the face of the tooth perfectly straight.

It does not shorten the tooth as done by upsetting. It has a positive clamp so a saw cannot slip while being swaged, therefore every tooth is an exact duplicate of the other.

Corners never drop off if swaged with this machine, as it does not injure the steel, therefore the teeth can all be kept of a length.

It is very simply constructed: nothing to break or wear out. Easily adjusted. Any ordinary man can swage a circular saw in from 10 to 12 minutes. Is thoroughly constructed of the best material, all the parts requiring it are made of steel of the best quality. Every swage is thoroughly tested before leaving the shop.

We positively guarantee the swage to do all we claim for it in this circular.

Full and complete instructions for adjusting and operating accompany the swage.

SEND FOR PRICE LIST OF

RHODES' IMPROVED

Automatic Band Saw Swages, Circular Saw Swages, Gang Saw Swages, Shingle Saw Swages.

—MANUFACTURED EXCLUSIVELY BY—

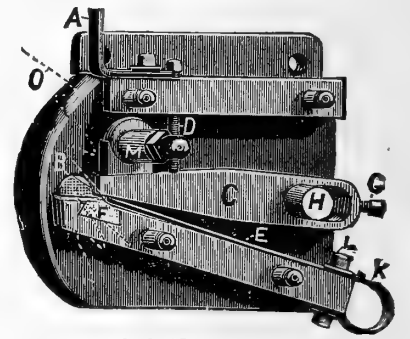

SECTIONAL VIEW.

P. O. BOX 430.

# Palmiter, Empey & Co., Galt, Ont.

Established 1849.

Incorporated 1884.



We use nothing but W. J. & Sons' English Steel in our saws and the name speaks for itself.

# Detroit Saw Works

MANUFACTURERS OF

## Circular, Gang, Mulay, Drag and Cross-Cut Saws.

MOLDING AND PLANING KNIVES,

French Band Saws, Emery Wheels and General Mill Supplies.

### 66, 68, 70 and 72 Fort St. East, DETROIT, MICH.

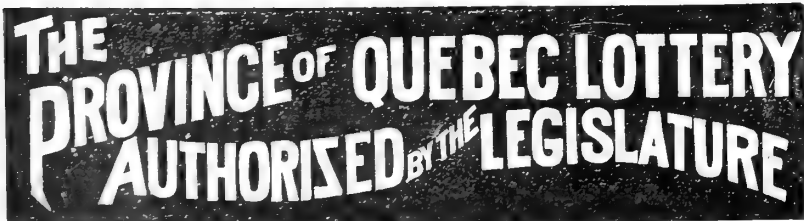

MONTHLY DRAWINGS ON

## 2nd Wednesday of Every Month

S. E. LEFEBVRE, Manager.

Head Office—31 ST. JAMES STREET, - MONTREAL.

PATENTED 5TH MARCH, 1877.

# PARKER & EVANS.

Sole Proprietors of the

FAMOUS INTERNATIONAL

## BOILER - FLUID - COMPOUND.

This compound will save its cost many times in one year by saving fuel.

It eradicates scale, and when the Boiler is once Clean a very small quantity keeps it clean and free from all incrustation. One fourth the dose will prevent a new Boiler from scaling so long as it is used regularly.

Contains no Caustic Soda, and is the only matter yet known that will not injure metals in any way, and emits a clear pure steam.

30 WILLIAM STREET, - MONTREAL.

# Friction Pulley Board.

The Best Materials ever used  
for Frictions of all  
\* kinds \*

MANUFACTURED BY

Asbestos  
Mill  
Board.

The **DOMINION LEATHER BOARD COMPANY,**  
Montreal, Quebec.

Steam  
Packing.

SAMPLES FURNISHED.

PLEASE MENTION THIS PAPER.

CORRESPONDENCE SOLICITED

# THE DODGE PATENT WOOD SPLIT PULLEY CO.

MAUFACTURERS OF

Pulleys of every description and style in stock and made to order.

Prices lower than any other first-class Pulley.

**Patent  
Split  
Belt  
Pulleys**

Every pully guaranteed strong enough for heaviest Mill Work, and to give more power with same belt than any other pulley made.

Send for Catalogue and discounts.

# Dodge Wood Split Pulley Co., City Office, 83 King St., W. **TORONTO.**

## B. F. Sturtevant's Patent Progressive Lumber Dry Kiln.

RELIABLE      RAPID!      CHEAP!

**GUARANTEED TO DRY**

-IN-

Best Manner Possible

ALL KINDS OF  
**HARD and SOFT  
WOOD LUMBER.**

WRITE FOR CATALOGUE.

91 LIBERTY STREET  
NEW YORK.

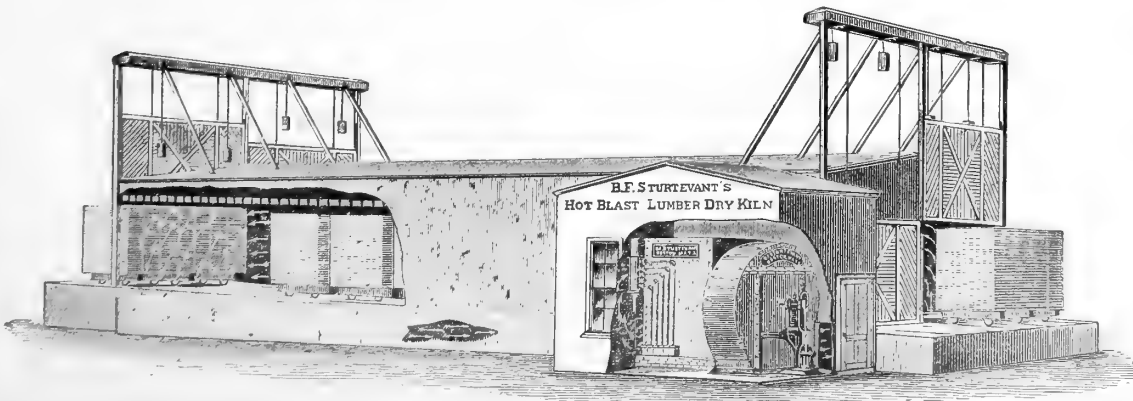

**NO WARPING  
CHECKING  
AND BLUEING**  
-WITH THE-  
**STURTEVANT  
Patent Hot Blast  
Steam Heating  
Apparatus.**

31 N. CANAL STREET  
CHICAGO.

**B. F. STURTEVANT, Patentee and Sole Manufacturer, 34 Oliver Street, (corner of Franklin street) BOSTON, MASS., U. S. A**  
*A. R. Williams, Soho Machine Works, Toronto, General Agent for the Dominion.*



# "DO YOU LACK STEAM? WE CAN HELP YOU!"

## THE GORDON PATENT HOLLOW BLAST GRATE.



A HOLLOW BLAST GRATE.

A new and novel application of a principle centuries old. Step into the nearest blacksmith shop and see

**N. B.**—Regardless of the character of your fuel, we can greatly increase the volume of steam generated by your boilers. It costs you nothing to try them. We guarantee satisfaction or no sale.

it in operation, on a small scale.

The **Hollow Blast Grate** supplies the furnace fire with a **blast of Hot Air** sufficient at all times to insure the rapid and perfect combustion of fuel of every sort.

It is the only successful appliance for generating steam from such fuel as the **SAWDUST** and refuse from hemlock, cypress and hard wood timber or from spent tan bark.

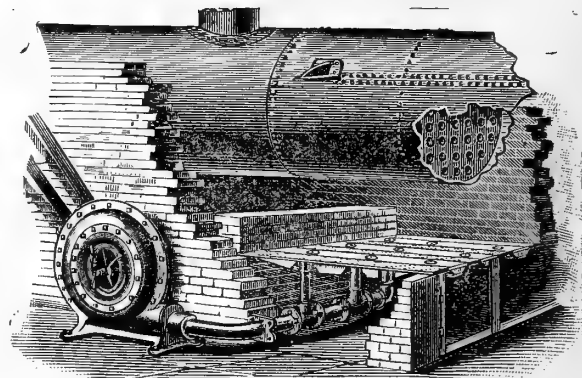

FURNACE FITTED WITH HOLLOW BLAST GRATES AND APPARATUS

### RECENT TESTIMONIALS

JOHN ORM, Pres. S. H. LANGSTAFF, Vice-Pres. GEO. LANGSTAFF, Sec'y. H. W. RANKIN, Treas.  
LANGSTAFF-ORM MAN'G CO.

Manufacturers of Lumber, Sash, Doors, Blinds, Etc. Long Steamboat Lumber a Specialty.

PADUCAH, KY., March 7th, 1891.

The Gordon Hollow Blast Grate Co., Greenville, Mich.

DEAR SIRS,—Enclosed find our cheque to cover amount due you for the Hollow Blast Grate Bars purchased from you some time ago. We have given the Bars a thorough test and are very much pleased with them; we find them to be all you claim.

Yours truly,

LANGSTAFF-ORM MF'G CO

JNO. N. PHARR.

F. B. WILLIAMS.

PHARR & WILLIAMS.

Band Sawed Cypress Lumber. Daily capacity, 100,000 feet. Extra Wide Lumber and Tank Stock a Specialty. 50 Million of Logs on hand. 6 Million Feet of Lumber in stock. W. U. Telegraph in office.

C. S. BURT, Esq.,

PATTERSON, LA., March 9th, 1891.

Baton Rouge, La.

Dear Sir—Our Grate Bars (Hollow Blast Grates) are now making us all the steam we wish. We had some doubt as to our boilers having sufficient capacity to furnish steam for our engine as they have only 100 horse power while our engine has 250; but we are now making more steam than we can use with cypress saw dust and refuse from our mill. Any one can figure the capacity of the boilers for themselves. There are four of them 32 feet long by 42 inches diameter, each with two flues 15 inches diameter. Our engine is 24x30. Anyone who is short of steam can not do better than to put in the Blast Grate bars. Yours very truly,

PHARR & WILLIAMS.

J. T. LITTLE LUMBER CO.

Lumber. Merchandise. One Mile from Mississippi City, L. & N. Railroad.

HANDBORO, MISS., March 9th, 1891.

To THE GORDON HOLLOW BLAST GRATE CO., Greenville, Mich.

GENTS.—We are now running our mill with the Hollow Blast Grates and instead of requiring two mule carts to haul away the saw dust, we now consume nearly all, giving us much better steam than we were forced to make it with wood and the small quantity of saw dust we could burn. We are satisfied that every mill man burning wood alone, or wishing to utilize the dust, bark, etc., for fuel will find by test, that the Blast Grates will reduce the labor and expense of steaming by one half.

Respectfully yours, J. T. LITTLE LUMBER CO.

BRINKLEY CAR WORKS AND MANUFACTURING CO.

Yellow Pine and Oak Lumber.

BRINKLEY, ARK., Feb. 7th, 1891.

To THE GORDON HOLLOW BLAST GRATE CO., Greenville, Mich.

GENTLEMEN,—We have your favor of the 5th, and beg to say in replying thereto, that the Hollow Blast Grates you put in for us are a splendid success, and we are more than pleased with them; by using them we are able to make enough steam to run our plant without having to put in another large boiler. We recommend them very highly. Enclosed find acceptance in settlement of account.

BRINKLEY CAR WORKS & MF'G CO.

H. H. MYERS, Sec. and Treas.

THE WOLVERINE LUMBER CO.,

CAIRO, ILL., Feb. 8th, 1891.

To THE GORDON HOLLOW BLAST GRATE CO., Greenville, Mich.

GENTLEMEN,—Yours of the 14th ult. at hand. In reply will say that we had grates placed and ready for use about the middle of December last, and by January 1st were

fully convinced that they were exactly what we needed. We could not think of trying to run without them for ten times their cost. We are running two band mills in green oak right out of the water, and are burning all our saw dust, leaving none to be carted away. The burning of the saw dust, with your grates, makes a very hot fire and keeps up steam splendidly without the use of any other fuel, excepting a very few slabs. We consider your grates to be what any saw mill requires. As for us, we would not think of trying to run without them. Yours truly,

THE WOLVERINE LUMBER CO.

A. E. STEVENSON, Supt.

SILAS KILBOURN & CO.,

Fish and Syrup Packages, Cider Kegs and Jelly Pails.

GRAND HAVEN, MICH., Feb. 20th, 1891.

To THE GORDON HOLLOW BLAST GRATE CO., Greenville, Mich.

GENTLEMEN,—Enclosed find check in payment for bill of Grates, etc. Please acknowledge receipt of same and oblige. The Grates are doing all you claimed, and more. Will save amount of your bill in better power and fuel in a short time. Before we put them in we had to buy a great many cords of dry slabs each year; we now burn nothing but saw dust and waste from factory, and have much better steam than before. We drive blower with a small "Dake" engine, which we think an improvement over connection with factory power.

Yours truly,

SILAS KILBOURN & CO.

DECATUR LUMBER CO.,

All Kinds of Rough and Dressed Lumber.

DECATUR, ALA., Feb. 12th, 1891.

To THE GORDON HOLLOW BLAST GRATE CO., Greenville, Mich.

GENTLEMEN,—Your Blast Grates are all that you claimed for them, and are very satisfactory.

DECATUR LUMBER CO.

A. W. LEE & CO.,

Oak, Pine and Hemlock Lumber.

BELSENA MILLS, PA., Feb. 12th, 1891.

THE GORDON HOLLOW BLAST GRATE CO., Greenville, Mich.

GENTLEMEN,—Enclosed find our check in settlement of account. The apparatus is in and does its work well. It is a decided improvement over the old. We recommend its use.

Yours truly,

A. W. LEE & Co.

C. C. MENGEL, JR., Pres.,  
Louisville, Ky.

A. W. WRIGHT, Vice-Pres.,  
Alma, Mich.

C. R. MENGEL, Sec.-Treas.,  
Louisville, Ky.

C. C. MENGEL JR. & BRO. CO.

Louisville, Ky.

Manufacturers of Poplar and Hardwood Lumber.

Mills: Trimble, Tenn.  
Oakton, Ky.

Office of

The Trimble & Kenton Railway  
is owned and operated  
by this Company.

Tipton, Tenn.  
Boston, Ky.

JAS. R. DEL VECCHIO, Supt.  
Trimble Mill.

TRIMBLE TENN., March 3rd, 1891.

GORDON HOLLOW BLAST GRATE CO., Greenville, Mich.

DEAR SIR:—Please find enclosed check in payment of our account. Your grate bars have given us perfect satisfaction, and a reference to our records shows that in one month previous to the time we put them in, we had 21 stops for steam, aggregating 6 hours and 9 minutes, or an average of 17 minutes to the stop. Since putting in your bars, on the same fuel in one month, we have had only 6 stops for steam, aggregating 1 hour and 22 minutes, or an average of 13 minutes to the stop. Before introducing your system steam was very seldom up to the limit and the machinery would be continually dragging; since your bars have been put in, if steam gets low the cause is in the fireman alone.

Yours truly,

C. C. MENGEL JR. & BRO. CO.

JAMES R. DELVECCHIO, Supt.

## The Gordon Hollow Blast Grate Co., Greenville, Mich.

Sole Proprietors of the Gordon Patents for the United States and Canada.

# Detachable Link Belting.



AS POSITIVE  
AS GEARING



AS PLIABLE  
AS BELTING and Elevating.

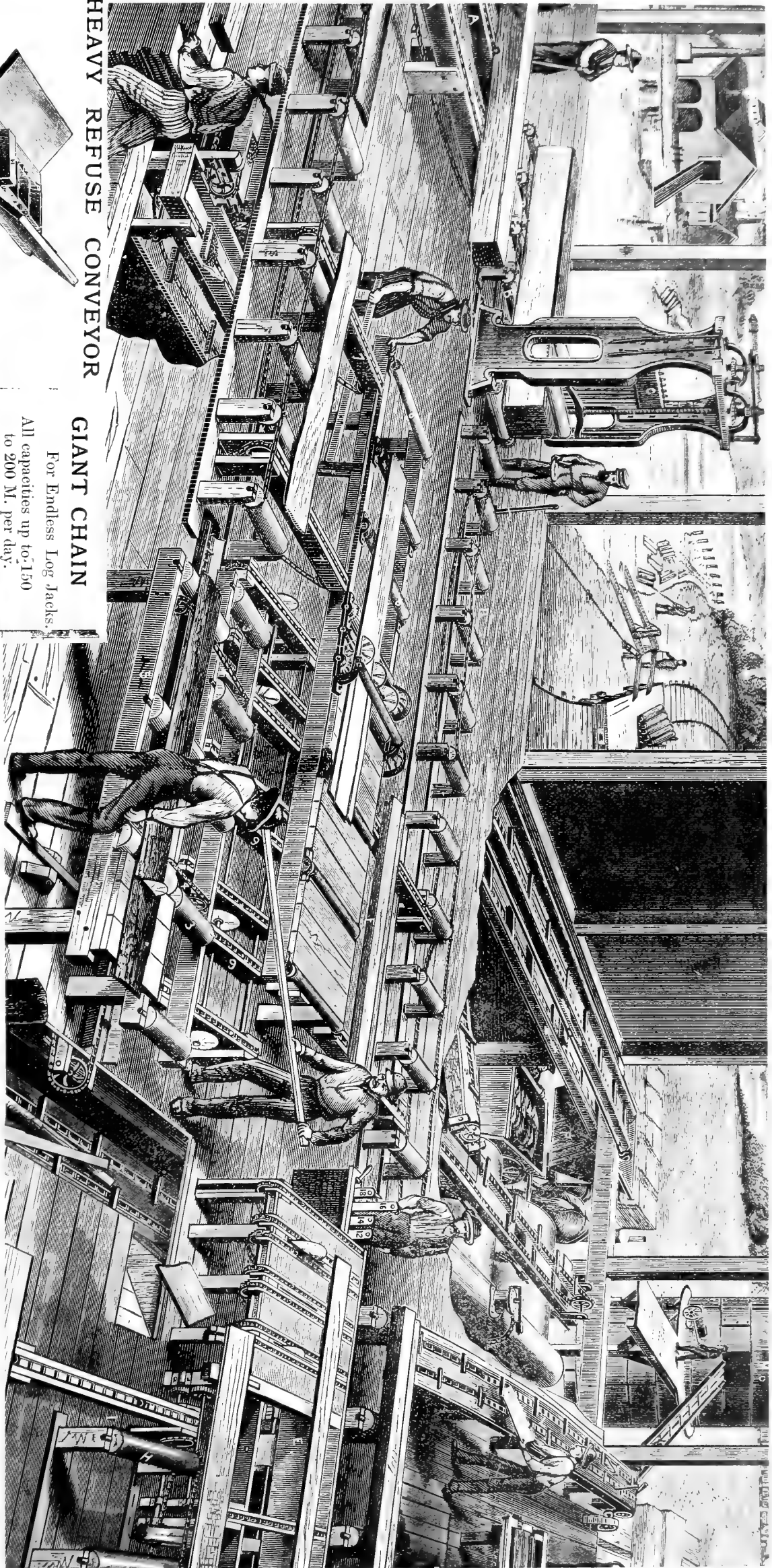

**HEAVY REFUSE CONVEYOR**

**GIANT CHAIN**

For Endless Log Jacks.  
All capacities up to 150  
to 200 M. per day.

Drop Flight Conveyor  
For Coal, &c.

Endless Apron Conveyor  
For Clay, &c.

Endless Pan Conveyor  
For Coal, Sand, Clay, &c.

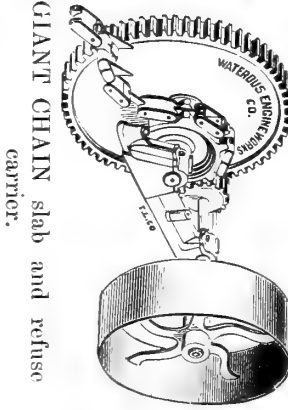
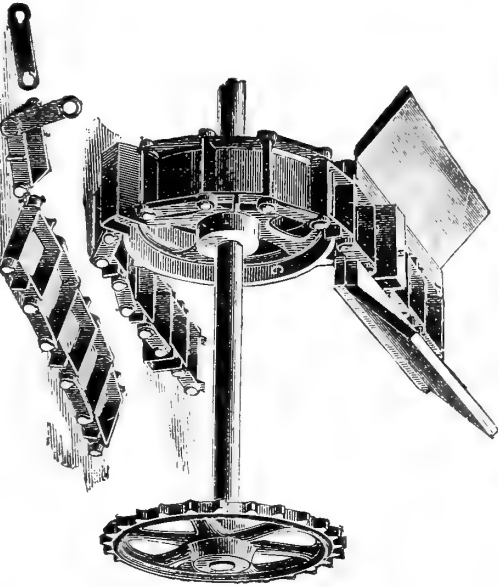

GIANT CHAIN slab and refuse  
carrier.

Automatic Sawdust feed to boilers.

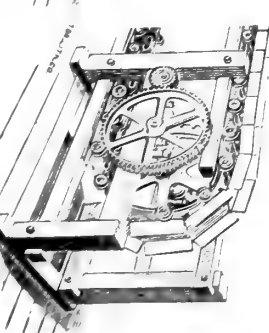
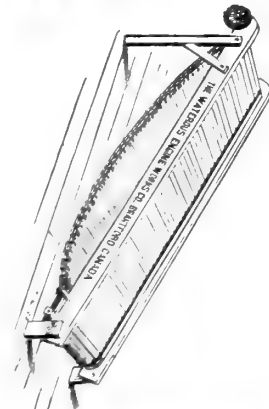
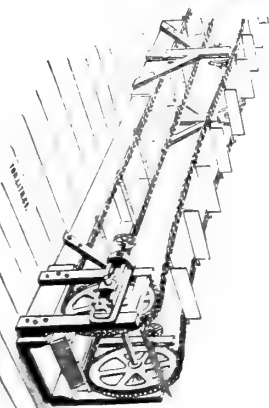

**SPRING MILL REPAIRING IS INCOMPLETE**

Without a full line of this Labor Saving device for Conveyors, Elevators,  
Live Rolls, Transfers, Lumber Sorters, Slash Tables, Trimmers, &c.

Send for Special Prices on Circular Saws during April.

All kinds of Mill Furnishings supplied at reasonable prices.

**WATEROUS ENGINE WORKS CO.**  
**BRANTFORD, CANADA**



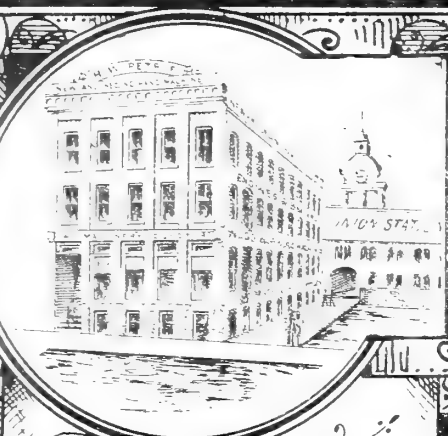

# PETRIE'S MACHINERY DEPOT.

*Special Bargains  
this Month.*

*Send for our Illustrated Catalogue  
New and Second Hand  
Machinery.*

One New Eclipse plane and Mather, Galt make.  
 Champion Planer, Mather and Moulder, nearly new.  
 Little Giant Planer, Mather and Moulder, price \$200.  
 24-inch Planer and Mather, Dundas make.  
 New Pony Planers and Matchers, only \$1 75.  
 24-inch Pony Planer, Frank & Co. make.  
 27-inch Double Surfacers, revolving bed—Cowan & Co. make.  
 No. 3 Revolving Bed planer, Cowan & Co. make.  
 24-inch Pony planer, Fess make, Buffalo.  
 No. 4 Pony planer, McKechnie & Bertram, builders.  
 Economist planer, mather and moulder, Frank & Co. make.  
 24-inch wood frame planer, Kennedy & Sons make.  
 1 planing machine knife grinder.  
 24-inch wood frame surface planer, cheap.  
 24-inch surface planer, Rogers make, Norwich, Conn.  
 23-inch surface planer, American build.  
 21-inch wood frame planer, Kennedy & Sons build.  
 22-inch surface planer, McKechnie & Bertram build.  
 22-inch wood frame planer, in good order.  
 20-inch wood frame planer in good order.  
 12-inch diagonal buzz planer, new, Galt make.  
 Daniels planer, R. Ball & Co. make.  
 Mather, Kennedy & Sons' make, Owen Sound.  
 Beading and moulding attachment for planer: Ross make, Buffalo.  
 No. 2 Three-sided moulding machine, Galt make.  
 3 Sided Moulder, made by Rogers Connecticut.  
 New power morticers—Galt make.  
 One chair or upright boring machine.  
 Iron top shaper—Goldie & McCulloch make Galt.  
 Centennial top jig saw—Goldie & McCulloch builders.  
 Double cope tenoning machine—Dundas make.  
 New 36-inch resaw—Galt make—also band resaw machines.  
 Tenoning machine—without copes—price only \$60.  
 Wood turning lathes—several sizes.  
 New combination saw table—all iron and steel.  
 Improved power rod feed machine—MacGregor, Gourlay & Co., Galt, builders.  
 No. 1 shaper—all iron—Goldie & McCulloch build.  
 Improved saw arbor—all sizes—Galt make; large stock.  
 One improved iron frame swing saw—new; Buffalo make.  
 Sawd paperers—new and second hand.  
 New dovetailing machine—Tyrell's patent.  
 New 30 and 36 inch band saws—Galt make.  
 New 25-inch band saw, Cant Bros. & Co. make, Galt.  
 Four fair scroll saws and three foot power; good order.  
 Three blind slot turners, all Galt make.  
 Dodge wood split pulleys at maker's prices; quick delivery.  
 Foot and hand mitring machines, latest design.  
 Foot and hand wiring machine, Galt make.

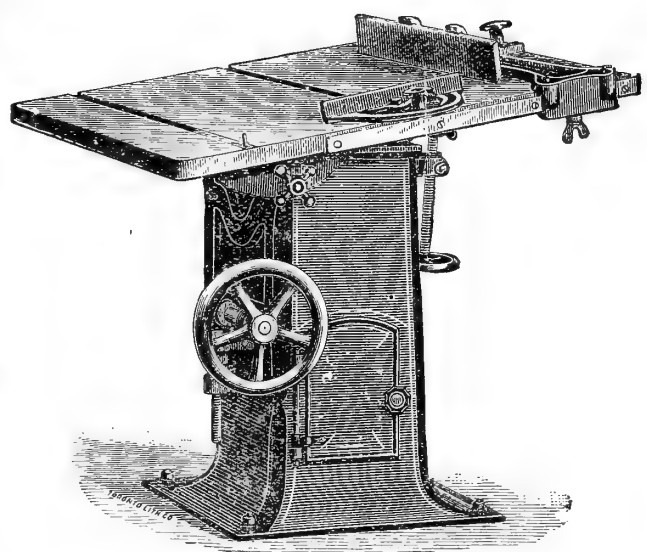

SAW TABLES---ALL KINDS.

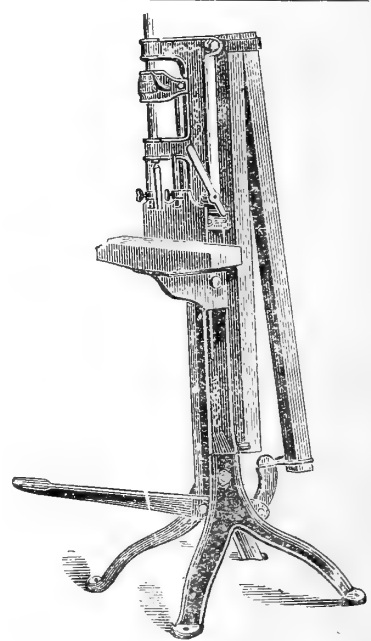

FOOT POWER MORTICING MACHINES

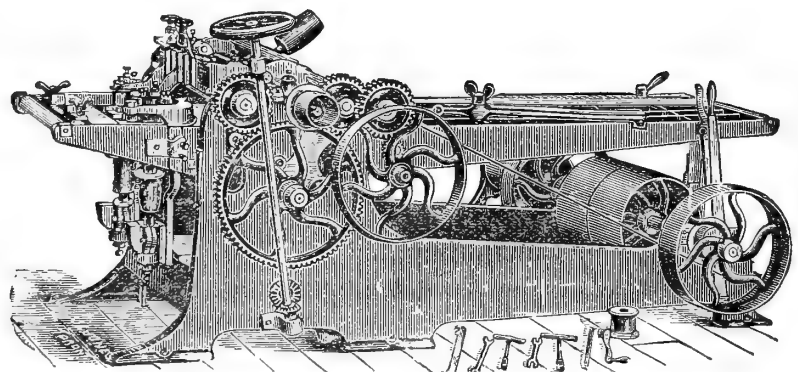

PLANERS AND MATCHERS  
ALL STYLES.

**H. W. PETRIE** PROPRIETOR. 141 TO 145 FRONT ST. WEST. **TORONTO, ONT.**



C. C. CLEVELAND. G. F. CLEVELAND.  
**J. L. GOODHUE & CO.,**  
 MANUFACTURERS OF  
**Leather Belting**  
 AND  
**Lace Leather.**  
 DANVILLE - - QUEBEC.

**One of the Greatest Chances in America**  
 For a Lumber yard or a Profitable Wholesale Wood-working Industry. One of the best located plants in Tonawanda may be leased, covering seven hundred feet docked water front on the Harbor; with ground five hundred feet in depth; large factory building, two hundred by one hundred and twenty-five, with basement; brick boiler and fuel room detached, suitable for sash, doors, blinds boxes, and custom planing combined. Tonawanda although carrying three hundred millions of lumber in stock has yet no large industry such as proposed. Will sell or lease for a term of years. Moderate rent, cheap labor, low taxes, lowest insurance.  
**SMITH, FASSETT & CO., Tonawanda, N. Y.**

**RAILROAD, BANK & OFFICE**  
**DESKS**  
**TEES & CO.,**  
 300 ST. JAMES STREET, MONTREAL.

**STORAGE OF LUMBER.**  
 We are prepared to receive any quantity of Lumber for storage. Freight and money will be advanced on same. Also, Warehouse Receipts issued, which can be hypothecated to banks and others. Storage charges easy. For further particulars apply to  
**W. LEAK & CO.**  
**Lumber, Coal and Wood.**  
**DUNDAS STREET, - - TORONTO.**

**GOODDAY, BENSON & CO.**  
 QUEBEC, P. Q.  
**General Lumber & Timber Merchants.**  
 Correspondence is solicited from parties having choice stocks of Hardwood and Pine to offer, either in the log or in sawn lumber.

**JOHN BERTRAM & SONS,**  
 CANADA • TOOL • WORKS  
 DUNDAS, ONTARIO.  
 MANUFACTURERS OF  
**WOOD-WORKING MACHINERY**  
 MACHINE TOOLS, ETC.  
 Write for Prices and Catalogues

**Packing Cases in Shooks.**  
 Any Saw mill in Canada able to undertake large orders for Case Boards is requested to communicate with  
**W. & C. PANTIN**  
 147 Upper Thames Street,  
**LONDON, - - - - - ENG.**

**GEO. CORMACK**  
 Wholesale and Retail Dealer in  
*All kinds of LUMBER.*  
 Lumber Shipped to all parts by Rail or Vessel.  
 WHITBY, - - - - - ONTARIO

William Hamilton, Water Works Department, Pumping House, Superintendent, Toronto, Jan. 6th, 1891.  
 ALONZO W. SPOONER, Port Hope.

Dear Sir,—I am pleased to say that after nearly three years constant use, day and night, on our largest engine your COPPERINE has stood its work well. I have not had to renew any of the heavy bearings yet, so I consider that speaks for itself. I am pleased to recommend it to any one in need of metal to stand heavy work.  
 I remain, yours truly,  
**J. C. FERGUSON, Chief Engineer,**  
 Toronto Water Works.

**A. T. ANDERSON & CO.,**  
 CONTRACTORS FOR  
**ELECTRICAL AND GENERAL MACHINERY.**  
 Complete instalations of Steam and Hydraulic Power, Electric Light and Power Plants, Wiring and Construction for Arc and Incandescent Lightings. Agents for the celebrated "C. & C." Electric Motors.  
 75 Adelaide Street East,  
 Toronto, Ont., Canada  
 Estimates furnished and every information cheerfully given to intending purchasers.  
 N. B.—Only first-class work on which a full guarantee will be given.

**THE RATHBUN COMPANY, The American Lumber Yard**  
 DESERONTO, - - ONTARIO,  
 MANUFACTURERS OF  
**Doors, Sash, Blinds, Stairs**  
 AND ALL KINDS OF WOODEN HOUSE FINISHING MATERIALS.  
**CEDAR OIL FOR PURGING BOILERS.**  
 CORRESPONDENCE SOLICITED

**HAMBURG, GERMANY,**  
 Offers the best facilities for Yarding and Selling all kinds of  
**American Wood Goods.**  
 Address: **ROSENBACHER & CO.,** **CARL GARTNER, Agent,**  
 BANKERS, Hamburg. Hamburg.

**ROBIN & SADLER**  
 MANUFACTURERS OF  
**Leather Belting**  
 DEALERS IN  
**Lace Leather**  
 Cotton and  
**Gandy Belting**  
 2518, 2520 and 2522 Notre Dame St.  
 MONTREAL.  
 129 Bay Street, TORONTO.

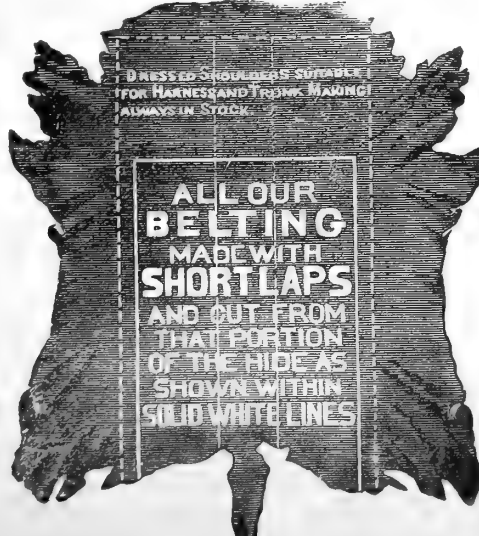

TAPER TOOTH.



TELEPHONE 5120.

**Burns**

&

**Thomas**



TORONTO.

MANUFACTURERS OF

All Kinds of  
CIRCULAR AND  
LONG  
**Saws**

LANCE TOOTH.



WORKS AT PARKDALE.

TO MILL OWNERS, MANUFACTURERS

AND ALL WHO ARE USING

# Leather \* Belting

IF YOU WANT BELTING

Which will Run Straight on the Pulleys,  
Which is Thoroughly Well Stretched,  
Which will not Tear at the Lace Holes,  
Which will give Complete Satisfaction,

— SEND TO —

## F. E. DIXON & Co.

MANUFACTURERS OF

PATENT LAP-JOINT STAR RIVET

### \* LEATHER \* BELTING \*

70 King Street East, Toronto.

Sole Agents in Canada for the

## CELEBRATED PHOENIX OIL

The Only Perfect Belt Dressing.

All our Belting is sold at the Canadian price list. Please compare before purchasing. Send for Discounts and our Pamphlet on Belting.

TORONTO AGENCY OF

## The Rathbun Co.

ARE OPEN TO PURCHASE

OAK, ASH, BIRCH,  
BASSWOOD

AND

GOOD PINE LUMBER

CEDAR AND PINE  
SHINGLES

Manufacturers having such for sale are invited to communicate with

**T. W. WALKER, Agent**  
**TORONTO**

Office, Cor. Spadina Ave. & Front St.



## SCRIBNER'S LUMBER AND LOG BOOK

Over One Million Sold.

**M**OST complete book of its kind ever published. Gives measurement of all kinds of Lumber, Logs, Planks, Scantling; cubical contents of square and round Timber; hints to lumber dealers; wood measure; speed of circular saws; care of saws; cord-wood tables; felling trees; growth of trees; land measure; wages, rent, board, interest, stave and heading bolts, etc. Standard book throughout the United States and Canada. Get the new illustrated edition of 1882. Ask your book-seller for it. Send post-paid for 35 cents.

**GEO. W. FISHER,**  
Box 238, Rochester, N. Y.  
or **A. G. MORTIMER,**  
Toronto, Ontario.

## WICKES BROS., Saginaw, Mich.

MANUFACTURERS OF

### GANGS, ENGINES AND BOILERS.

The accompanying cut represents our new No. 3 Complete Iron Frame Gang Mill especially designed to meet the demand for a smaller type of mill. The strongest and most durable for high speed and thin saws. Write for further particulars.

Southern Agents,  
**McARDLE & SINCLAIR,**  
50 & 52 Barronne St.  
New Orleans,  
La.

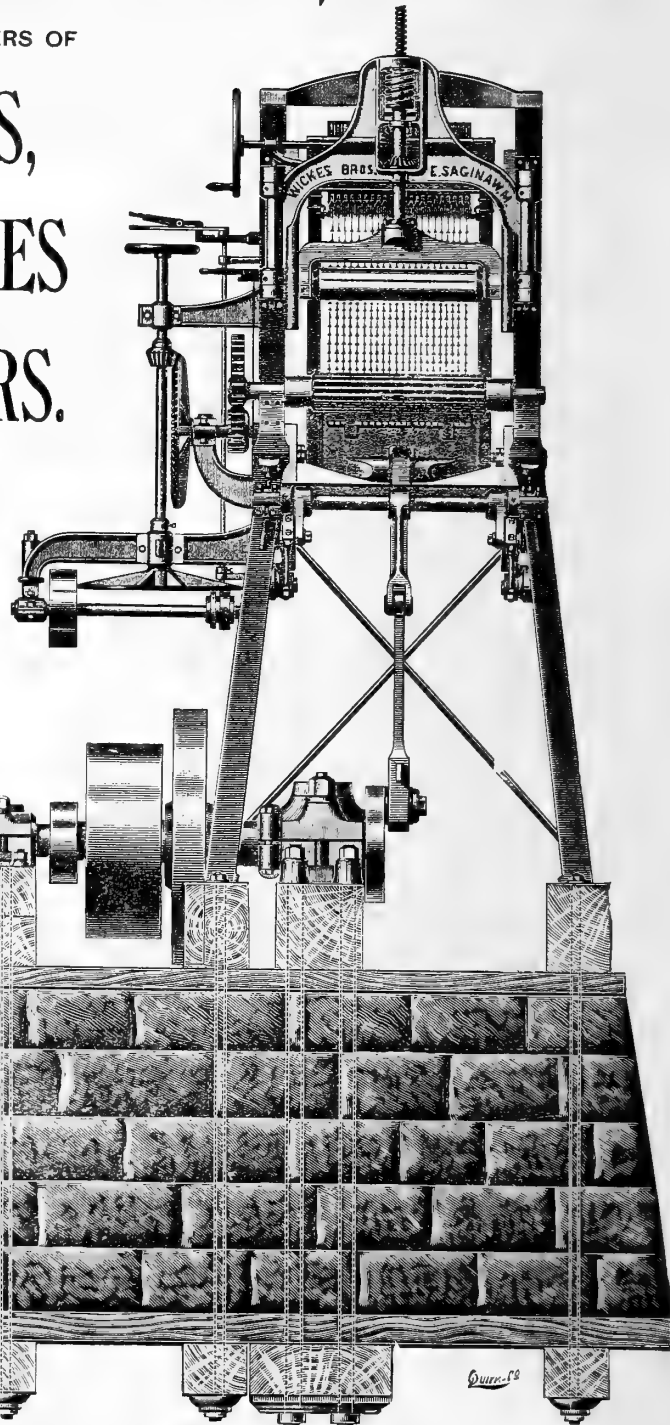

## Fawcett & Co.

### MERCHANT \* TAILORS,

269 Queen St. E., Opp. Seaton St., Toronto.

First-Class Goods and Trimmings. Workmanship and Fit Guaranteed.  
All Orders Punctually Executed.

# THE CANADA LUMBERMAN.

VOLUME XII }  
NUMBER 5 }

TORONTO, ONT., MAY, 1891.

THE CANADA LUMBERMAN  
PUBLISHED WEEKLY

## THE SPANISH RIVER MILLS.

THE accompanying is a cut of the mill property of the Spanish River Lumber Company, on the Spanish River. The limits in connection with this mill aggregate almost 400 square miles fairly timbered with pine. Both mill site and 300 square miles of the timbered lands originally belonged to Mr. John Cameron. He erected the first mill in 1864. From him the property passed into the hands of Mr. M. Smith, and later to Mr. John Chaffy, whose heirs sold it to Messrs. Arnold & Fulsom, of Albany, N. Y. They erected entirely new mills on the old site, introducing modern equipment and largely increasing the capacity. Both lath and lumber are manufactured, the annual product of the latter aggregating 25,000,000 ft. The new mill was erected in 1883, and has been running steadily since that time, and quite a settlement has sprung up around it. Steam power is employed entirely. Facilities for transportation are provided by three steam barges owned by the proprietors of the mills. Between 80 and 100 men are constantly employed. The senior members of the firm are both dead, but their interests are represented in the company by their sons.

tremes of the subject. They both went into a lumber region about the same time, obtained about the same timber advantages, had about the same amount of capital; as far as two men could be they were on a level and equipped to make an equal start. Having been in the business elsewhere, their experience of course taught them as to the first steps necessary to be taken. In a short while they had their plants erected, their teams in operation, and their log pile well supplied with good stocks, to make a start with. They thawed up almost simultaneously, and for quite a while were neck to neck in the race; gradually, however, it became evident that A, we'll call him, was in the lead somewhat. He added more hands and later on he put on a night force. Soon another planer had to be added, then a small dry house, which finally had to succumb to a more modern dry kiln. It was noticed that more empty freight cars were constantly standing on the side tracks that led to his mill than were seen on the siding of his rival not far distant. And so on, could we enumerate the different tangible evidences of the expansion of his business, while there were equally as many indications attesting the fact that B was still pegging away at about the same rate of speed as on the day

latter replied that weatherboarding and such like, from other mills, came dry as a bone, while his was not so well seasoned, and purchasers invariably gave preference and more money for the dryer and lighter lumber. A, clear-headed as usual, grasped the idea in an instant. By drying his lumber he could not only secure a better price, but he could save money in freight; so it didn't take him long to decide upon putting up a dry kiln. Not long after he found that the boiler and engine he had pulled his machinery sluggishly, and it occurred to him that several horse-power additional would send his machinery buzzing along at a livelier rate, and thereby enable him to saw more feet of lumber in the day than formerly. He therefore put some of his earnings into a new engine and boiler of increased capacity. The outcome of it was that he had likewise to add to his force of men to keep pace with the productive power of his plant. All this while his competitor B was contenting himself with the same outfit he started with, and was plodding along in about the same pace as when he first begun. Through the indifference of his hands, time had habitually been lost, and the output of his mill had consequently been curtailed, depriving him of so many dollars profit. He

## THE SAW MILL.

BY EDWARD A. OLDHAM.

ECONOMY is one of the cardinal virtues with the progressive lumber manufacturer of the present day. But there has been a time in the not very remote past when very little stress was laid upon this subject, and there are even instances, today, where this matter is totally disregarded, but the men who disregard it are not within the category of progressive, and as an accompanying result, they are not overly prosperous in their business. Year after year their noses become closer to the traditional grindstone, and they lay awake nights wondering where the fault lies.

Too few business men have an eye to the small leaks in their business. This has been very generally the case with new mill men, until experience has taught them many a costly lesson, by which they have benefited. The saw-mill man must of necessity be a utilitarian. He must learn how to utilize every atom of everything turned out by his mill; he must study intently the small economies of his business, and stop up the little insidious leaks that gradually eat up the profits, and in time begin their ravages upon the business itself.

I am not going to write a technical article on this subject. That is not what is needed. Saw-mill men are not always technical in their training. They have to be approached in a practical, common-sense sort of way, with appeals to their pocket as well as to their reason.

Probably no better way can be found to comprehensively illustrate the importance of carefully attending to the small economies of a saw-mill than by drawing a parallel between two men representing the two ex-

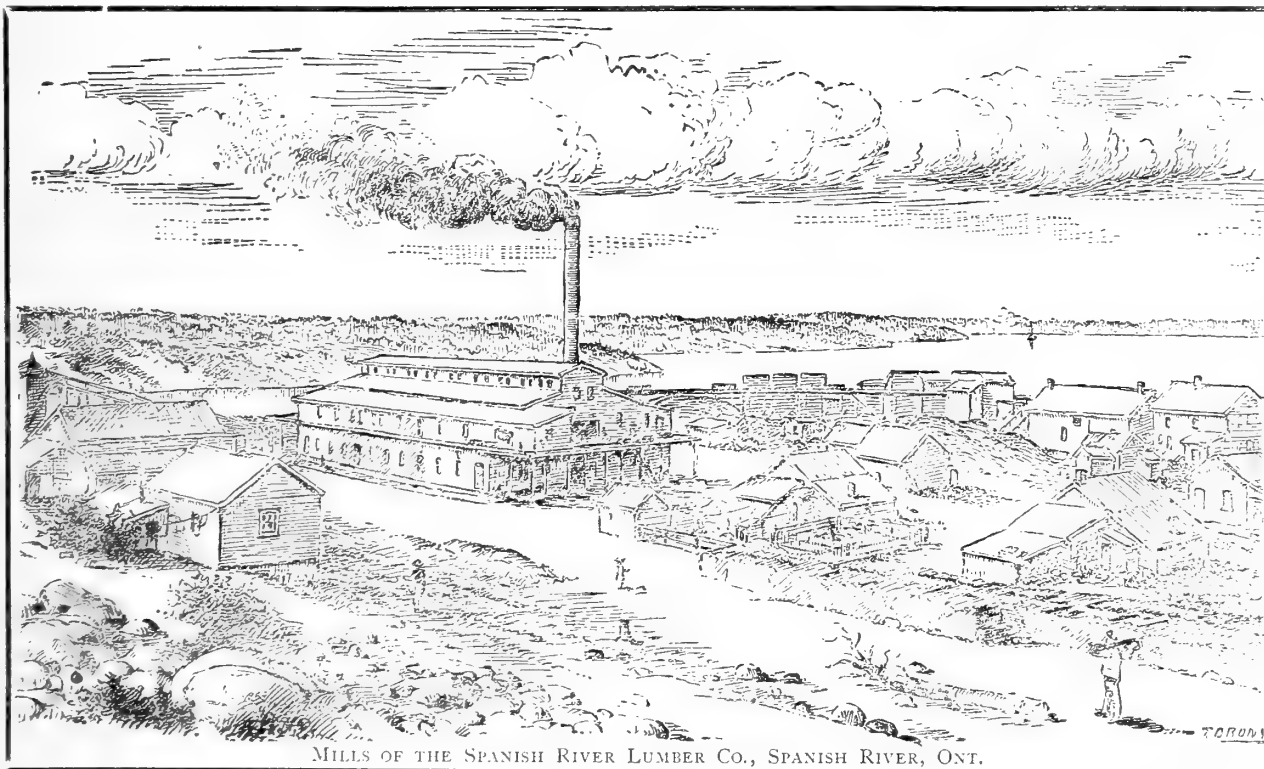

MILLS OF THE SPANISH RIVER LUMBER CO., SPANISH RIVER, ONT.

both mills started out upon the race for priority. The situation was interesting enough for a man in the business, but to a thoughtful layman it afforded an extra degree of fascination. I began to study the two men. I visited their respective mills. I talked with each about the business of saw-milling in general, and his in particular. I drew each of them out and became acquainted with their methods. The first discovery that set me to thinking was that A was a subscriber to several lumber journals. His conversation told me that he was keeping pace with the advancement of saw-milling, the advent of new improvements in processes and appliances, and with the relative profit to be gained by shipping to this or that market. On the other hand I found B took no lumber paper, and to my profound astonishment, was not aware that such papers were published. He was an intelligent man, too, with apparent zeal for the building up of his business.

A discovered one day that he was not getting the highest market price for his planed stuff. He inquired of his agent in the city what the matter was, and the

got out of funds on one or two occasions, and had to stand his men off. At this they naturally demurred, and grew discontented. Some left, and others kept on the alert to get positions elsewhere. B believed in that kind of economy that curtailed the wages of his operatives, and he drove bad bargains with his men, deceiving himself into believing that he was saving money thereby. His wiser competitor being a practical workman himself, knew the full value of labor, and paid a good price for a good man, promising the latter better wages if he became a better workman. Each man stood on his individual worth, and each man very naturally strove to make his individual worth greater.

The next thing I learned was that A was his own sawyer most of the time, while B not only never touched this part of his business, but left it in charge of another, and for days never went near his mill, being occupied at his office a good distance off. A, by working himself, saved the amount of a sawyer's salary, had the work executed more satisfactorily, got better work and more of it out of his men. Around both mills there soon began to accumulate a vast heap of sawdust. It got to be quite an item of expense hauling it away from beneath the saw to a point fifty or sixty feet distant. A determined upon utilizing this idle factor as fuel, so he wrote to one of his lumber journals and told the editor he wanted grates that would enable him to burn this granulated fuel beneath his boilers, and through this channel he got into correspondence with manufacturers who sold him the kind of grating he desired, and in a short while he was handling his sawdust only a few feet, whereas before he was handling it sixty feet. De-



sides this small economy he had instituted a tremendous saving in his fuel expenditures. B continued to pile up his sawdust, and in order to get rid of it he undertook to burn it, but on more than one occasion his plant narrowly escaped destruction by sparks blown from the dust pile.

Both mills were sawing pine exclusively, and as a matter of course the "slabs" accumulated rapidly, until around each mill there was a large pile of this stuff, representing so many dollars of idle capital going to ruin. A glanced at the growing heap one day and bestirred himself to remedy this leakage. How could he best utilize this surplus raw material? He used some of it as fuel along with the sawdust, and found that he could get a better heat, and therefore more steam by judiciously adding the two than by burning each separate, but this only called for an atom of that immense pile of outside boards. What should he do with the remainder? He did not ask himself the question long, his habitual perusal of his trade papers had whetted his ideas, and he quickly realized that the best way to put this idle material to profitable use, was to buy a lath machine and hire an extra man or two to operate it. He did so, and soon he was shipping laths away in car load lots, and making a very snug profit out of them, too. B allowed this object lesson to pass unheeded and he continued to pile his slabs higher and higher, where negroes in the neighborhood had frequent access to them after nightfall.

A had arranged a plan to utilize his sawdust, was no longer troubled by an increasing pile of slabs, but still there was a quantity of refuse material too good to dump into his furnace. He thought awhile on that line and he soon found a market for the "kindling wood," and henceforth broken laths and bits of board were dumped into the dry house and made as ignitable as tinder, after which they went to a small swing saw and were cut into eight-inch length, after which they were tied into little round bundles about a foot in diameter. These were laid out flat, standing the sticks on end, and a boy with a mop applied a thin coat of cheap rosin to the exposed ends, from a huge pot standing over a slow-burning fire near by. None of the work of preparing these kindling blocks for market was done by a man; boys were intrusted with the work and the proprietor himself superintended it. There was another thorough system and method about A's mill. He gave the signal himself, and all hands turned to or knocked off when he did.

Experience had taught him that it was the best sort of economy to be regular about all things. At B's mill the sawyer had rules, but being an employe himself did not enforce them as strictly as the proprietor would have done if he had been there in actual touch with the work, and rules not enforced were often worse than no rules at all, and in that way very much valuable time was lost that represented so many dollars and cents wasted. Is it necessary to draw the parallel any farther. I think not. Any intelligent, common-sense man acquainted with the saw-mill business in the remotest degree cannot fail to see where such a parallel ultimately leads to, indeed it may hardly be termed a parallel any longer; one of the knives is short and straight, the other early diverges and where it terminates is not in sight.

In conclusion it is safe to lay down this general proposition, that the man who extracts the most gratifying results from the saw-mill business, is he who watches steadfastly after the small economies around his mill, for if he is a business man enough to do that, he is apt to be ambitious to push his business instead of allowing it to push him.

#### MAHOGANY.

The weight of a cubic foot of mahogany varies from 35 to 33 pounds. As compared with oak, which is called 100 per cent. the strength of mahogany is 67 to 97, its stiffness is from 73 to 93, and its toughness from 61 to 99 per cent. The Government engineer of Honduras estimates the total value of the trees in that country, such as are regarded fit to be cut, at \$200,000,000, while the smaller trees, not ready to cut, are also worth a large amount

#### OUR CROWN LANDS.

THE annual report of the Commissioner of Crown Lands, which is now to hand, is a volume of more interest than the majority of Government returns, containing as it does a comprehensive statement of the management of the Province's great stores of wealth. It shows that the total collections of the Department were \$1,113,052 and the total disbursements \$290,953. The area of clergy lands sold during the year was 780 acres, aggregating in value \$1,219.76. The amount collected on account of these and former sales was \$6,037.88. The area of Crown Lands sold during the year was 50,045 acres, aggregating in value \$79,847.39. The collections on account of these and sales of former years amounted to \$74,031.78. The area of common school lands sold during the year was 220 acres, aggregating in value \$766.50. The collections amounted to \$11,758.24. The number of acres of grammar school lands sold during the year was 534, aggregating in value \$367. The collections were \$1,538.27. Under "Railways Aid Act" of 1889 certain lands were set apart to be sold for the purpose of forming a fund to recoup the province in respect of moneys expended in aiding railways—of these lands 9,406 acres were sold, aggregating in value \$18,577.20. The collections were \$11,562.56.

The total collections from woods and forests for the year amounted to \$916,155.67, which includes \$135,479.53, on account of bonuses, leaving the revenue from timber dues, ground rent, etc., to be \$780,676.14.



HON. A. S. HARDY, MINISTER OF CROWN LANDS.

The revenue from woods and forests is somewhat below the estimate, which is accounted for by the collapse in the square and waney board timber trade, there being very little demand for this class of timber during the past year. The report goes on to say this reduction of the import duty upon sawn lumber going into the United States from \$2 to \$1 per thousand feet board measure came too late in the year to have very much effect on last season's business, although there was a stiffening towards the close of the year, due, no doubt, to the reduction in question. The quantity of timber being got out this year is very small, and there is also a reduction in the output of logs. It is reasonable, therefore, to expect for the coming season a fair business at remunerative prices, and that the reduction of the American import duty will enlarge our market to some extent—more particularly for the coarser grades of lumber.

In order to enable those owning mills in the north-west part of the province to obtain supplies of timber, in harmony with the policy prevailing in other parts, it was determined to hold a sale of a limited area of timber berths as soon as the necessary surveys and explorations could be completed. The sale was held on the first of October last and there was a large attendance. Four hundred and eighty-five miles were offered, all of which, except 18½ miles, were in the territory west of Thunder Bay. Three hundred and forty-three and three-quarter miles were knocked down on the day of sale, for \$321,956.25, and thirty-three

miles were sold subsequently at the upset price, realizing \$24,300, making a total mileage sold of 376¾, realizing \$346,256.25, or an average of \$919.06 per mile bonus for the mere right to obtain license. There has been paid on account \$110,729.53, leaving outstanding \$235,526.72.

The work done during the year on colonization roads was as follows: Miles of new road constructed, 180; miles of road repaired, 400; bridges erected, 30; bridges repaired, 12. The work done was carefully inspected and reported to be of a satisfactory and substantial character. The total expenditure was \$127,577.60, of which certain items amounting to \$2,770.20 were refunded, leaving the net departmental expenditure to be \$124,807.40.

#### A SERMON IN A SENTENCE.

WE pay that man six dollars a day, said the proprietor of a small shop recently to us, for the reason that he is the best man on that kind of work, and we think ourselves very fortunate to get him. When we heard this we could not but wish that some who think the world is too full, and there is no demand for skilled labor any more, could have heard it also. There never was a time, there never will be a time, until the end of all things is at hand, when skilled labor will not be in demand. There is always an overplus of mediocrity, and half-hearted men who work for six o'clock have only themselves to blame when they are unable to keep jobs. Not many months since we were talking with a very intelligent man who was posted, so to speak, on all things outside of his business. He was a machinist, and when we broached some topics connected with his trade he shut up like a steel trap; that was the one thing he took no interest in, and it is almost needless to say he had no position in it; he was a general utility man, fit only to hew wood and draw water, and it is fair to presume, so lax was he in all matters incident to his business, that he spilled most of the water and made more chips than firewood. This man, when asked if he took a trade paper, said promptly that he did not. "Why should I? if I was the best workman in the world the boss would only get the benefit of it; I would not get any more." Argument with a man like that is impossible, and we said nothing; but it is a curious fact that the superintendent of this very works said, as we were going over it: "I want a man for foreman of one of these shops; and would you believe it, there is not one out of the whole 600 that I would trust. I never saw such a lot of men in my life; they don't care for anything. There isn't a single mechanical paper taken by one of them, and yet they are a fair average."

Now the caption of this article and the commencement explains the situation as regards advancement in life for those who wish to get on. It is for young men that we write, not for those who have run their race. If you expect more than a bare living—and an uncertain one at that—you must be able to do some one thing better than the mass can do it. No matter if it is only chopping wood—whatever it is, do that one thing better than nine out of ten can, and you will be in constant demand. All men can not be foremen, that is certain; but to be a foreman implies that you can do something else better still if you will cultivate the same qualities.

One of the most difficult things is to convince young men that they are not known for what they are; that they can be good workmen and bad workmen and the world will not take cognizance of either fact. Assuredly it will; every man is known to his immediate associates for exactly what he is. He is under their notice all the while, and they do not fail to see his daily walk and carriage; this being the fact, it is easy to get a good or bad reputation. If a young man has his way to make let him cultivate all things that are lovely and of good report. Be assiduous at his trade, do the best he can, and take counsel of his superiors. If he shows that he is in earnest, everyone will lend him a hand.

Talking about striking a tender chord, soliloquized the tramp at the wood pile; this is one of the toughest cords I ever struck.

## USEFUL INFORMATION

Know that the pulleys are well balanced before they are put in position, as a pully much out of balance is quite a sure method to throw shafting out of line.

If the speed of a conveyor connecting the flow between two performances alternates from fast to slow, and vice versa, an interruption to regular flow will result on the last operation.

When a grain cleaning machine runs above proper speed it is liable to break the wheat, and if it runs below it will not make an accurate separation; hence, if for nothing else, it will pay to provide a reliable speed governor to keep the grain cleaning machinery at proper speed.

The steam engines of the world represent, approximately, the working power of 1,000,000,000 of men, or more than double the working population of the world, the total population of which is usually estimated at 1,455,023,000 inhabitants. Steam has accordingly enabled man to treble his working power, making it possible for him to economize his physical strength while attending to his intellectual development.

Here is a method of making an emery-wheel dresser: "Take a piece of  $\frac{3}{4}$ -inch round iron about 14 inches long; heat it and split up about four inches; bend the two sides made by splitting into the form of a letter U, leaving a handle 10 inches long. Now drill  $\frac{3}{8}$ -inch holes in each end of the U, put  $\frac{3}{8}$ -inch bolt through and fill with  $\frac{3}{8}$ -inch washers. This will make a perfect emery dresser."

Smoke pipes may be preserved from rust by painting the pipe thoroughly, either with coal or wood tar, then filling it with shavings and setting them on fire. The heat roasts the tar, and, at the same time, opens the pores of the iron, which become filled with carbon, and thus preserved from rusting for an indefinite period. A smoke flue is mentioned which was thus treated twenty-six years ago, and is still in good condition.

Air is an absolute necessity in good combustion. That is understood pretty generally, yet there are engineers who forget it when they put in grates with insufficient openings for air or think that cleaning a fire often does little good. Select a grate that has over 50 per cent of air space, and a rocking grate makes cleaning the fire an easy operation and without cooling down the boiler.

Possibly it is not in order to criticise old sawyers, but there are men who claim the title of sawyers who do not know the first principle of milling. They file saws to the disadvantage and ruination of their employers. A saw should be swaged with a lever or tongue swage or set with a Disston saw set. In order to cut smooth lumber, a side file should be used. A good sawyer will not depend upon the guide pins. File the saw correctly, and the result will be satisfactory to yourself and employer. Too many sawyers do not file the saw correctly, and depend upon the guide pins for good work, and when the saw does not do good work it is blamed for what is really the sawyer's carelessness.

The practice of removing the manhole plate in the front head of a hot boiler, says Mr. W. H. Wakeman, in the *Manufacturers' Gazette*, and then inserting the hose, and allowing the cold water to run along the bottom to the blow-off pipe, is a bad one, for if the bottom of shell is suddenly cooled off, while the top is still in contact with the heated masonry and other covering, unequal contraction and a severe strain on some of the parts is the inevitable result. This may be practiced for years without ruining the boiler to outward appearance, but the worst defects we have to contend with are those which would escape the notice of the casual observer, and when boilers that are thus misused finally "let go," it is voted a mysterious dispensation of Providence.

Edwin A. Kimball, instructor of the shops at the University of Illinois, writing on the subject of preventing slipping of belts, says: "I do not know that washing soda may not be as good as castor oil, for I never used the former; but I do know that castor oil is effective and safe in the hands of a competent person. There is no occasion to soak a belt in any sort of oil. A little applied to the surface is sufficient. There is nothing that I have ever tried that is so effective as castor oil, especially for wood-working machinery belts. The way to apply it is to let it run from a bottle in a small stream on the belt while this is in motion, commencing at one edge of the belt, moving the stream over a little at every full travel of the belt, until the whole width of the belt has received its portion. I know of belts that have been treated in this way for years, and they are whole yet, and doing their work without a murmur

### LUMBERMEN IN THE LEGISLATURE.

THE lumbering interests of the Province of Ontario are represented in the Local Legislature by fifteen members engaged in lumbering pursuits either as owners and operators of saw mills or as holders of timber limits, and in some instances as both. Of these the Hon. E. H. Bronson, whose picture we here publish is a Minister of the Crown.

Mr. Bronson is a member of the well-known firm of Bronson & Weston, who operate extensive mills and control large interests on the Ottawa. He is the eldest son of Mr. H. F. Bronson, a native of Warren County, N. Y.; he was born at Bolton, Warren Co., in 1844. He received his education at Ottawa and Sandy Hill, N. Y. He has been a member of the Ottawa city council for seven years and of the school board for a much longer period. In 1874 he married the only daughter of Prof. N. B. Webster, of Norfolk, Virginia. He was first elected to the Legislature as a member for Ottawa in 1886. Last June he was re-elected by the enormous majority of 1,460.

It is in keeping with the fitness of things that a business holding such an important relationship to the prosperity of the entire Province should be thus fully and ably represented in its councils.

Crossing over from the Government benches to the opposite side of the House, we find in Mr. A. Miscampbell the new member for East Simcoe, a man prominent in lumbering sections and who is destined to come quickly to the front in Legislative circles. His speech on the Budget



HON. E. H. BRONSON, MINISTER WITHOUT PORTFOLIO.

in the recent session of the Legislature was perhaps the ablest delivered by any of Mr. Meredith's supporters. In another column along with a portrait of the author, we publish an extract from this speech, touching specially on lumbering interests and which will furnish a good illustration of this gentleman's style in debate and trend of thought on public questions. Mr. Miscampbell spoke with force on the Mining measures of the Government and also on the shantymen's Lien bill.

Another member who delivered one of the chief speeches in the mining debate was Mr. Jas. Conmee, member for West Algoma. He was born in Sydenham in 1849, and is now a resident of Port Arthur. He is extensively engaged in lumbering and railway construction.

Mr. W. C. Caldwell, B. A., of North Lanark, is another lumberman, and son of the former member Mr. Alexander Caldwell. E. C. Carpenter representing North Norfolk, whilst now engaged in agricultural pursuits was for some years in the employ of the Rifle River Booming and Rafting Co. in Michigan. South Norfolk is happy in its choice of a lumberman, in the person of W. A. Charlton, a resident of Lynedoch, and where he is engaged in mercantile and lumbering business and with his brother John Charlton, M. P., for North Norfolk, has interests in the Georgian Bay region and Tonawanda, N. Y. One of the most active members of the Assembly is Mr. James Clancey, of West Kent, a lumberman of Wallaceburg. Mr. John Fell, of North Victoria, for some time ran a shingle mill at Fenelon

Falls. Robert Ferguson the member for East Kent lives at Thamesville where he carries on a lumber business. One of the new members of the Legislature brought in by the June election is Wm. McCleary representing Welland. He is a member of the firm of McCleary & McLean, lumber dealers and saw and wood manufacturers. Centre Simcoe claims a new member in Mr. Robert Paton, of New Lowell, who is extensively engaged in stock raising and lumbering. David Porter, of North Bruce, has been engaged in saw milling since 1877. Jas. Reid, of Addington, worked for many years in his father's saw mill and was engaged in lumbering. The member for North Waterloo, Mr. Elias W. B. Snider, is a manufacturer and owner of several mills including a saw mill. One of Mr. Meredith's most active supporters is Mr. A. F. Wood, of North Hastings, a gentleman largely interested in manufacturing and railroad interests, holding for some time the position of president of the North Hastings' Lumber Company.

### THE BIG TREES OF BRITISH COLUMBIA.

IT may well be imagined that it is no boy's play to cut down a tree from five to ten feet in diameter. The axemen work in pairs, and after selecting the place where they desire the tree to fall, they begin operations. Trees generally have a swell at the base that is cross-grained and gnarled, hard to cut, and not good timber, and as it is not desirable to have this in the log it becomes necessary to cut the tree above this defect. Some trees, especially the fir, have a great deal of pitch at the base, and this, also, renders it desirable to begin cutting some distance from the ground. Another advantage of getting above the ground is being out of the way of brush and fallen timber.

In order to do this the axeman chops a notch in the tree nearly as high as his head, the notch being about six inches deep and about the same in length, and inserts in it the end of a board, upon which he stands to wield his axe. The board is a piece of oak or fir from four to six feet long and about ten inches wide, the inserting end being narrower and bound with steel, upon which is a calk like that on a horseshoe, which holds the board firmly when the man's weight is on it. If the first notch is not high enough he cuts another higher up, and still another, if necessary, using the boards as steps, until he is often ten or twelve feet above the ground before he finds a suitable place for chopping. The two axemen, having thus gained a position on opposite sides of the tree, begin the work of chopping with their double-bladed axes, working carefully so as to direct the fall of the tree in the line selected. Of late years the improved style of two-hand saws has been made to do the chief work. After cutting with the axe a deep line in the tree on the side to which it is to be made to fall, the men begin sawing on the opposite side, wedging the cut made by the saw as they progress, thus keeping the saw clear and gradually inclining the tree in the right direction. In this way a tree may be made to fall in the direction exactly opposite to its natural inclination. When the tree shows symptoms of falling the men give a few well-directed strokes with the axe to guide it in its course, and then spring lightly to the ground, standing near the base of the tree, which experience has proved to be the safest position. Gradually the forest giant bows its head, its fibres cracking like pistol shots, until, at last, it comes down with a rush, its limbs dragging down others with it, and the under ones being splintered into pieces.

### HOW WOOD PULP IS MADE.

IN wood pulp making by the sulphite process, the wood is peeled, discolored or decayed parts are removed, the wood is cut across the grain into thin chips, which are dropped into large drums about 14 feet in diameter, 24 long, and strong enough to sustain a pressure of from 75 to 200 pounds to the square inch; when packed full of chips the drum is filled with sulphuric acid and other chemicals, and the cotton-like product is pressed dry and mashed, mixed with water, rolled flat and cut into shape for bundling, being 60 per cent. moisture and 40 per cent. fiber. Thus it goes to the paper mill. One cord of spruce makes 1,200 pounds of dry fiber worth from \$100 to \$150 a hundred pounds.

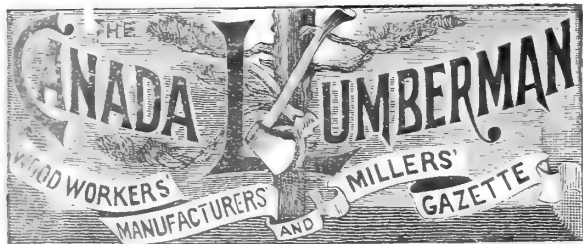

PUBLISHED MONTHLY BY

ARTHUR G. MORTIMER.

OFFICE:

75 CANADA LIFE ASSURANCE BUILDING.

TORONTO, ONTARIO.

TERMS OF SUBSCRIPTION:

One Copy one Year, in Advance, - - - - - \$1.00  
One Copy six months, in Advance, - - - - - 50

Advertising Rates Furnished on Application.

## TO VISITING LUMBERMEN.

LUMBERMEN visiting Toronto are invited to use the office of the LUMBERMAN as their own. We shall take pleasure in supplying them with every convenience for receiving and answering their correspondence, and hold ourselves at their service in any other way that they may desire.

## PROTECTION TO SHANTYMEN

THE Lumbermen's Lien act carried through the recent session of the Ontario Legislature by the Commissioner of Crown Lands is designed to give to shantymen the same privileges as are extended to other workmen under the Mechanics' Lien act. It provides that wages shall be deemed a first charge on all logs and shall have precedence of all other claims or liens thereon.

In principle the measure is sound. Experience has proved that special legislation for the protection of those, who of themselves, are powerless against unscrupulous employers, has become a necessity. This particular bill, however, contains several clauses that, whilst aimed to protect one class of the community in particular, bears unfairly on another class, who unfortunately at the present time feel that their lot is not an easy one.

The bill is made to be operative only in the Algoma, Thunder Bay and the Rainy River districts—the border districts. Here, it is alleged, is the greater temptation for sharp practices on the part of jobbers, who will see an opportunity to hurry their logs out of the country, too often without paying the men who have done the burden of the work, the wages earned. While cases of this kind have occurred and have been more common to the districts named in the bill than elsewhere, it does not follow that like fraudulent acts may not be committed in other lumbering sections. In the discussion in the House preceding the passing of the measure it was pointed out by Mr. Wood that there were complaints of dishonest jobbers in the Trent and Moira districts. Mr. Dunlop said there was a desire for a bill of this nature in the Ottawa district, and Mr. White cited reasons for its extension to Essex. But aside entirely from local reasons, if the principle of the bill is sound, it should be general in its application. It should not be a case of waiting until irregularities show themselves in a community before a law already in existence is made to apply to that particular locality. This looks too much like locking the stable door after the horse is stolen.

The clause which will operate most severely on the lumbering interests is that which says that "such lien shall remain and be in force against such logs or timber in whosoever possession the same shall be found." It is not denied that there are men engaged as jobbers in lumbering, who, like those in many other lines of commerce, are working on a limited capital. They are just as honest as the men who have ten times the capital, and because of their known honesty credit is given them on the logs or timber they buy, pending the closing of sales on their part. Now, if the lumberer who gives this credit has got to take the additional risk of having a possible wage bill tacked on to his account and the very logs for which he has not yet got his pay, seized and perhaps sold at a sacrifice, through

no dishonest intent, but the unforeseen misfortune of the jobber, he is very apt to draw a strict line in future on the matter of credits, and the consequence will be the crowding out of business of many deserving men and honest jobbers. Even though the jobber should never have done otherwise than pay every cent of wages he has ever contracted he will be treated in the same way as the rascal who goes into the business with full purpose of "doing up" workmen and everybody else. When business men establish rules, forced on them by exceptional circumstances, the rules have to be general to all.

This phase of the matter is further aggravated by another clause which provides that if "such labor or services be performed or done on or after 1st day of April and before 1st day of October in any year," then action in law can be commenced within twenty days after the last day such labor or services were performed. Here we are at the close of the season and it would not be difficult for those troublesomely disposed to cause action to be entered against a jobber for the one purpose of having the logs held long enough to make it impossible, owing to the setting in of severe weather, to have them carried through to their destination that winter. Even if such action were entered with a proper purpose, serious loss on all hands would follow in the same way.

The lumbermen are not forgetful of various wise measures of the Provincial government helpful to their interests, noting specially their recent action making it a condition of timber sales that all logs cut in the territory disposed of shall be manufactured in Canada.

It is a disappointment in this latest measure that the objectionable features referred to were not at least modified and still the general principle of the bill which all lumbermen we believe approve of, preserved.

## FOREST PRESERVATION.

THE tendency of human nature is to "put off," so long as the worse results that we know will eventually follow some given course of action, have not actually developed. We see this illustrated in the case of tree planting having in view the preservation and renewal of our forests.

The possibility of a scarcity of timber in this country of so much wood is passed over as the dream of an idealist or the vaporings of a mere theorist. Yet, with the inroads that are being made in our forests to-day, the time may not be so remote as we anticipate, and we will wake up too late to reap the gain that would have come from a little prudent forethought, and less of the indifference of the present day.

Much careful reflection has been given to this subject by Mr. Phipps, of the Forestry Department of the Ontario Government. In his latest report he suggests as a practical method to encourage tree planting, the opening of a large public nursery, where trees might be obtained free of cost, and that under a system of free saplings, twenty times as much planting would be done as at present. This proposition involves an expenditure of public money, which Mr. Phipps justifies in this way: "The work is national; it is the nation that desires the farmer to plant trees; it was the fault of the nation that he was ever allowed to obtain public land at first without an agreement to retain a certain portion in trees." The great error of the original settlers, he says, was taking hill and hollow, mountain and vale, indiscriminately, with the result that many mountain tops were cleared, farmed and ruined by the washing away of the soil. "That the mountain should be wooded and the sloping valley cropped, is the very A B C of forestry."

Captain Eads, an American writer on the subject refers to the indiscriminate destruction of forests in his country in the following vigorous and picturesque manner: "The United States is tearing out the heart of the country with her gang ploughs and throwing it into the Mississippi river."

The testimony of 200 farmers has been given to prove that years ago, when there was still much timber standing, most crops gave a far better return than since more has been cleared.

This is a very practical side of the question—one

that involves dollars and cents, and should weigh against the measure of sentiment that some of our too utilitarian people think surrounds this question. Otherwise future generations may rise up not to bless us, but mad enough to consign us to some unmentionable region where fire wood is supposed to be more everlasting than Canadian woods may have proved to be.

## THE QUESTION OF DUTY.

OPINIONS differ among lumbermen as to the wisdom of removing the duty on logs going into the United States. Two separate interests come into conflict with each other. The mill men see only a curtailment of the work of their mills and a transference of this labor to Michigan mills. The owners of timber limits on the other hand are already feeling the impetus that the abolition of the duty is giving to the sale of their logs and lumber; and that these sales are running into large figures there can be no question. THE LUMBERMAN has taken some trouble to enquire on this point, and finds that here both mill owners and owners of limits are at one. We give a few figures that will be suggestive of what is being done in exporting. N. Holland, of the Saginaw Lumber and Salt Company will export 30,000,000 feet from Canada; J. W. Howry & Son, of Saginaw, 20,000,000; and Sibly & Bearinger as many more; about 35,000,000 will be taken from Lake Superior, and Alger, Smith & Co., will raft about 80,000,000 feet from Algoma.

The workmen recognizing what this means are agitating for a reimposition of the duty, and it is possible that at the present session of the Dominion House the matter may be taken up. But this is only one view. It does not follow, nor is it likely, that the large quantities of logs that will be rafted across the border would, if the export duty were reimposed, be cut in Canada. Some will be, but the larger quantity would remain in *statu quo*.

There is the other important phase of the question that cannot be left out in a fair consideration of the entire problem, viz: That whatever drawback does exist as a result of the abolition of the export duty, is it not more than offset by the gain in the lessening of the import duty on Canadian lumber going into the States? Let our government reimpose the duty on logs, and the United States government, it is believed, would at once retaliate by again clapping on the import duty on lumber.

It would seem to be the consensus of opinion that it was unnecessary—and it was not asked for—for our government when removing the duty on pine logs, to have also included spruce. One large Canadian concern, the E. B. Eddy Manufacturing Co., of Hull, has already interviewed the government and asked for a reimposition of the duty on this product. They use spruce in their sulphite fibre works, where by a simple process of treatment with sulphuric acid, the wood of the spruce is converted into sulphite fibre, from which the finest qualities of paper are made. The products from the works, which average 300 tons monthly, finds a ready market in Canada and the United States. The company, however, is already being handicapped because of the Americans coming over here and buying up all the available spruce. It is a serious injustice to the lumber interests of New Brunswick where the larger portion of spruce is found, while no advantage to offset this loss is presented. In the new department of the LUMBERMAN, "Eli," it will be interesting, and not without its funny side, to read the various views of the trade on this and kindred questions. There one can "speak right out in meetin'."

Among the questions that the census enumerators are instructed to ask are the following regarding the products of the forest: Number of square cubic feet of white or red pine, oak, birch and maple, elm, black or other walnut, and hickory produced for the census year; cubic feet of square or sided tamarac and all other timber; number of standard pine or spruce logs, spars and masts, thousands of staves, cords of lathwood, tan bark, firewood, pulpwood, and number of fence posts, railway ties, telegraph poles, and thousands of shingles taken out.



# EDITORIAL NOTES

PRESIDENT HARRISON issued his proclamation last week reserving from settlement 1,750,000 acres of timber land in the northwestern portion of Wyoming adjoining the Yellowstone National Park.

THE rag picker no longer holds the key to the situation in the manufacture of paper. Wood pulp has worked a solution in paper making. Rags are still used for the finer grades of paper, but for print papers and the cheaper grades of writing wood pulp has the field.

BEHOLD what a great fire a little matter kindleth—and one would expect many such taking the average daily out-put of matches in the Eddy Company factories at Hull, Que., as a criterion. No less than 22,000,000 matches, or four for every man, woman and child in the Dominion, are turned out daily in this establishment.

THEY are using more walnut in Europe at this time than is usual, and considerable quantities are now going forward from eastern points to meet the foreign trade. Operators are disposed to think that the trade is about at its highest pitch however, but Europeans are disposed to take all they can get of a quality that suits them, at prices prevalent in the seaport markets.

BLACK birch is rapidly coming into favor in building circles. When properly stained it is almost impossible to tell the difference between it and cherry or walnut. In the forests throughout Ontario birch grows in abundance, especially if the land is not too boggy. There is a great difference in the wood of different sections. Where the land is high and dry the wood is firm and clear; but if the land is low and wet, the wood has a tendency to be soft and of a bluish color.

THE forestry exhibit at the Columbian Exposition at Chicago will embrace wood in its natural state from every section of this and other countries, thus affording a most excellent opportunity for comparing the same varieties growing in different latitudes and the climatic effect on forest growth. Worked timber in all of its many commercial forms will be shown by beautiful specimens selected from the wood-working establishments of the world, including the various ornamental woods used in furniture, veneers, and interior decorations.

THE owner of a planing-mill in Chicago has been sued for \$10,000 damages because a six-year-old boy, who was bringing beer to the mill for some of the workmen, accidentally got caught in the machinery and was injured.—*Ex.*

Beer is bad stuff to get inside a planing mill or inside workingmen. The amount claimed for the boy's injuries is a good round sum. But if it results in prohibition being made the law not only of the mill, but individually of the men employed both in and out of the mill there will in the end be full return received for the \$10,000.

THE Winnipeg assessment rolls for 1891, which have just been completed, show the total assessment to be \$19,995,370, an increase of about a million and a third over last year's return. This increase is accounted for, partly by the large number of buildings erected during the past year, as well as improvements and repairs made to premises generally throughout the city and partly to the advance that has taken place in the value of outside property, a large proportion of which has changed hands at prices far in excess of former assessments, and something approaching a valuation has at last been imparted to all that kind of property. The exemptions remain at \$4,000,000 and the personal property assessment of \$2,375,000 show a slight decrease from that of last year. The population is 27,000.

AGENTS of the General Land Office, appointed in June last by Secretary Noble to investigate alleged large timber depredations in the Rainy Lake and Rainy River country, in Northern Minnesota, by both American and Canadian parties, have made their official reports. It is stated in the reports that such definite information of large depredations has been obtained as will enable the government to sustain actions at law against the trespassers. The yearly average of logs passing through the Rainy River is said to be between forty-five and fifty million feet.

WE have all heard of the well known Forth bridge of England, which it is claimed has more steel in it than any bridge that is or ever was. Canada is a "wooden country," so our old country friends say, and can claim the greatest wooden bridge extant. We refer to the Canadian Pacific Railway Company's new bridge at Milford, Manitoba. It is 3,300 feet long and 75 feet high. There were used in the work 1,300,000 board measure, 1,300 piles for supporting the trestle, and 150 piles for the abutments of the Howe truss of the great span. And it was all completed in five weeks.

THERE are from 30,000 to 100,000 olive trees along the confines of the Province of Gilan in Persia, which yield on an average 6 pounds to 90 pounds of olives per tree per annum or roughly a gross annual produce of 750,000 pounds. The value of the oil after a good harvest is from 1s. 2d. per bottle of two pounds at Resht or Teheran, whereas the maximum price paid after a bad harvest is about 3s. Rudbar, the centre of the production, is situated on the Safeed Rud, which from that point is navigable down to the exit into the Caspian Sea, during the greater part of the year, for strongly built barges or rafts and for flat-bottom boats. Every olive tree is subjected to a Government tax of about 1½d.

IN Buffalo, N.Y., complaint is made that mill men are cutting prices, and that every effort to remedy the evil has so far failed. Here as in almost every department of trade comes that bane of all trade—"cutting." Probably nothing that we can say will be half as effective as the efforts of their own people. We do say, however, in most emphatic terms that history has yet to record an instance where "cutting" in any branch of business ended in other than disaster. The rope may be longer in some hands than others, but there is an end to even the longest rope. The funny part is that men who are shrewd in every other way, and who put on the brakes to stop the leakages everywhere else do nothing to dam the greatest of all leaks—too often constantly widen the channel to give greater flow to the losses.

A CONTEMPORARY writes of the "coming timber," as we might expect a dry goods man to talk of the coming fashion in bonnets. It is the case however, that fashion changes in woods as it does, in a greater or less degree, in almost all other mundane things. Just now with our American friends the warmest appreciation is going out to the yellow pines of the southern States. The output is already nearly three-fourths that of white pine, and there are sanguine ones who predict that it will yet double that of its northern rival. Yellow pine is claimed to be susceptible of as high and beautiful finish as the white pines of the higher latitudes. Hitherto it has been regarded as too full of resinous gum and too coarse grained for fine wood working finish. The same idea is also prevalent in England. But this prejudice is quickly disappearing. It is said to be harder than white pine and more enduring.

IN another column we publish, along with a portrait of Hon. A. S. Hardy, a very complete summary of the report of the Commissioner of Crown Lands for 1890. It deals at considerable length with the marked development that has taken place in the mineral wealth of the province. To applicants in the districts of Algoma, Nipissing, Rainy River and Thunder Bay, who have filed plans, an area of mineral lands of up-

wards of 14,000 acres have been sold, for upwards of \$28,000 has been received. The total receipts for the year from woods and forests amount to \$916,155.67, which includes \$135,479.53 on account of bonuses, leaving the revenue from timber, due ground rents, etc., to be \$780,676.14. The report bears a careful reading by all engaged in lumber industries.

VANKLEFK HILL, a thriving village in the county of Prescott, is in high glee over the news that the Central counties railway company expect to have the line from Glen Robertson to the village completed by November next. The population is now about 2,000, and which it is anticipated will increase rapidly. Lumbering is carried on extensively in this region, and it is expected that the new railway line which is to connect at Coteau with the American system will enable the large dealers and holders of lumber to ship at any season of the year to Boston, New York and other cities in the United States. The railway company have a bonus of \$15,000 from the municipality of West Hawkesbury, and a number of small bonuses from farmers along the line. THE LUMBERMAN trusts that all the good things that our friends along the Ottawa anticipate from the increased railway facilities will be realized. Just see to it that you have got the railway solid—if such a thing is possible—on all its promises, so that some day when you most need its service, it will not kick back on you. Railway corporations, and heavily bonused ones too, have done that kind of thing before.

"SPEARING" for timber is a new industry, says a London paper, which has been developing for the past few years in Ireland, and is a form of timber prospecting never dreamed of some years ago, not even by "American pine hunters." Geologists know that immense tracts of what are now bog lands in Ireland were formerly covered with forests of oak and pine, and that in cutting peak immense trees of both these varieties are found embedded in the earth, at depths of 10, 20 and 30 feet. In some cases, whole groves are found standing just as they grew hundreds of years ago. A visitor to the wild region of Donegal thus describes the way in which the seekers after buried forests operate. Two men armed with long steel rods 30 or 40 feet long, traverse the bog, and by running the rods into the ground are able to find where the trees are to be found. They fix on a patch of land 20 or 30 feet square and cross it with their searchers north, south, east and west. Having searched across each way stabbing every foot of the inclosed space, they quickly learn whether it contains what they are looking for. The timber when obtained is, we learn, generally found to be perfectly sound, and the oak, which is as black as ebony, is used extensively for ornaments of jewelry and fancy cabinet work, and sells at high prices.

ONE of the best known lumbermen in the Dominion is Mr. J. W. Phillips, a resident of this city. He is the owner of extensive timber limits in Newfoundland, situated on the Gander river, near the island of Fago, on the north-east coast. He is owner also of a large mill at Point Limington, and is now engaged erecting a second mill, docks, etc., at a cost of about \$125,000. Though a resident of Toronto for upwards of thirty-two years, as a native of Newfoundland he takes a warm interest in all its affairs, practically shown in his large material interests in this colony. He has recently returned from a visit of some weeks to his native place, and to an ubiquitous interviewer has unbosomed himself on the possibilities of this colony that to-day is attracting world-wide attention because of her fishery affairs. He considers her agricultural capabilities second to those of no province in Canada. She is rich in minerals and timber resources. Combatting an idea, quite general, that the "extreme weather" is a drawback to the cultivation of the soil, he gives the official figures to show that when the mean temperature in Toronto marked 44.3, at St. George's Bay, Newfoundland it was 43.8, while at Winnipeg, Man., on same day it stood 30.8. It was at Bonavista, now a large harbor, distant from St. John, Newfoundland, about 100 miles, that Christopher Columbus, it is said, first sighted land.



ELI'S greetings to readers of the CANADA LUMBERMAN who are to be found in the wide Dominion, in nearly every state in the American Union, and reaching England, Germany and even far away India, a subscription coming to us this month from Burmah, India. I shall chat freely in this column about various matters pertaining to lumbering and kindred interests. Readers will have every opportunity given them to express themselves. Bright, shrewd sayings of the brightest and shrewdest of our business men—for where do you get them, if not in the lumber trades?—will be caught on the 'fly' by Eli as he wanders to and fro among the trade and will be recorded here. In a word it will be a page for the interchange of opinions with readers and writer, where without restraint each may feel free to say his own say in his own particular way. Your introduction to Eli.

♦ ♦ ♦  
"Take my word for it," said a lumberer to the writer a little ago, "there is not the slightest danger of the Americans tacking on an increased duty on lumber, should we reimpose the duty on logs. They want our lumber too bad."

♦ ♦ ♦  
"There can be no doubt," remarked Mr. A. H. Campbell, of the Muskoka Milling and Lumber Company, "that the yellow pine of the Southern States is going to seriously break in on the sale of Michigan pine. It will not fill the bill in every case where white pine is used, but it is a useful wood. The one great drawback will be transportation, but when there is the stuff to ship satisfactory arrangements can usually be made for shipping."

♦ ♦ ♦  
In the lumbering sections in the Ottawa region and especially out on the Pacific coast among the Indian villages and logging camps, I am told the census enumerators are having a jolly time. Two men will take an open boat with a supply of provisions and go to the Howe Sound to enumerate the population, and from there they will go northward along the coast as far as the upper end of Knight's Inlet, a distance of upwards of 300 miles. How would some of our city enumerators like the job?

♦ ♦ ♦  
"Just how far astray the daily papers will get," said lumberman John Donogh, "in their anxiety for news is shown in the boom that the city dailies are endeavoring to work up in building lines. Their prediction is that 1891 will prove a busy season and they cite the number of permits issued as proof. We are directly interested in seeing a lively trade done, and I wish the prognostications of the newspaper press were correct. The building permits are certainly a long way ahead of those of a year ago, but be it remembered that the fire limits have been widely extended within the year. Last season's building was not nearly represented by the permits registered at the city hall. There was building outside of the fire limits that these little documents told nothing about. This year the building is in the main covered by the permits."

♦ ♦ ♦  
I see that Mr. H. E. Clarke, one of the members for Toronto, drew the attention of the Legislature at its recent session to the extent of the timber cut in the Province. He quoted from statistics furnished by the Legislatures of Michigan, Wisconsin and Dakota, which show that these states, so it is stated, are so deficient in their timber that they cannot supply the home consumption for the next ten years, and also that New Hampshire and Vermont have virtually exhausted all their forests. "No one," said Mr. Clarke, "can find fault with the government if they cause to be cut down every stick of timber in the country, if it is done to make room for settlers, but such is not the case. It is being done to supply our neighbors to the south with an article that is growing scarcer every year, and must increase in value as time goes on."

♦ ♦ ♦  
I find in discussing trade questions with men engaged in any line of business that it makes a good deal of difference whose ox is gored. The color of our spectacles vary a good deal—sometimes. I had been spending a pleasant half hour in the office of a leading jobber in this city, a few days since, who in discussing the question of duty on logs, had no hesitancy in saying that it would be a serious blunder to reimpose the old duty. It would certainly materially affect his trade. I had not left this gentleman any length of time be-

fore I ran across a mill owner from the Midland district. "Well," said I, "how are things your way? Getting ready for a big season's trade?" No trade at all was the reply. The abolition of this export duty has completely killed mill operations. I have sold my mill to an American firm, and they have closed it down—so you can draw your own conclusion as to how the duty business works."

♦ ♦ ♦  
"Do you know," remarked one whose opinions on lumbering are worth something, "that the abolition of the duty on logs is going to raise a bigger noise than those Ottawa fellows ever dreamed of. It was a simple matter with one scratch of the pen to give away our forests to the Americans, but it will not be so easy to recover the ground that is now fast slipping from under us."

I had to confess that there was some cause for my friend's indignation, at the same time I asked him to read over the "Eli" page when the LUMBERMAN would get into his hands this month and see how a "house was divided against itself," some lumbermen holding to one view and others to the opposite.

"All this will not alter the cold facts that the mills in the regions directly affected by the measure are closing down one after another, hundreds of men are being thrown out of employment, and Michigan saw mills are both getting our logs and doing the cutting. Let me go back a little in history," said he. "You know that some six or eight years ago the Americans did this same kind of thing—they bought our logs, rafted them over to the Michigan shore and kept their big mills in a continued buz. To give to our own people who surely have a right to the bounties of their own forests some show an export duty of \$2 per thousand ft. was placed upon Canadian pine logs by the Dominion Government. What was the result? Immediately our saw mills all through the Midland, Little Current, Spanish River, and other lumbering regions took on a big boom, and such men as Mr. Miscampbell, Cook Bros. and others were able to give employment to hundreds of working men. Our woods swarmed with them, villages thrived, store-keepers did a rattling trade, boats were kept running, and progress marched apace on all hands. I know what I am talking about when I say that this last movement of our government has changed all this, and the leading mills throughout the Midland, Little Current, Algoma and places along the north shore are as a consequence closed down, and will remain closed unless the duty is reimposed."

Hold on, I said, you are showing us one side of the shield only with a vengeance. Do you suppose that Sir John Macdonald, the father of the National Policy, a measure designed specially for Canadian industries and workmen, abolished this duty simply for the fun of the thing? Did he not get in return the reduction of from \$2 to \$1 import duty on Canadian lumber going in to the States, thus giving encouragement to every manufacturer of lumber in the country—and especially in the region named by yourself—and as a consequence is not manufactured lumber being shipped to the States in increased quantities by our Canadian shippers? Reimpose the duty, have the import duty raised, and the trade with the United States in Canadian lumber will be seriously curtailed.

"The experience is all against you," persisted my irrepresible friend. "I will grant that shippers are doing an increased trade because of the reduction of the import duty, but mill owners are not getting any marked benefit. There is a surplus of sawed lumber in a large number of yards consequent on the depression of a year ago, and this is being shipped across the border to-day. This stock exhausted and shippers will feel the pinch just as the mill men do to-day."

Do you mean to say that our people will cease manufacturing? You know the old adage that it is easier for the mill to come to the logs, than for the logs to go to the mill. We have got the logs and the mills are planted beside them.

"This is very plausible and might count for something if certain special factors did not exist. (1) The Americans have their own saw mills on their own side of the lines—some very large ones—and they have got to keep them running. If it were not for this it would probably pay them to 'cut' in Canada, notwithstanding the dollar duty on manufactured stuff. (2) If the duty on logs remain off for any length of time, they will have sufficient lumber in their Michigan yards manufactured from Canadian logs, cut by their own workmen, in their own mills, these without costing them a cent of duty, to be perfectly independent of manufactured stuff from Canada. In a word what need will there be for them paying even one dollar duty on lumber, when they get the stocks in free of duty in the shape of logs and manufacture, if I may so put it, on their own premises?"

There seemed to be no "downing" our saw mill friend. He recognised the fact that the owners of timber limits had a large amount of capital invested in the woods of Canada, and that the abolition of the duty on logs meant that these gentle-

men were now getting a nice turn over on their investments and from their standpoint it was perhaps proper for the government to concede to them certain privileges. But was it right for them to do this at the cost of the complete ruination of other important interests, which if not representing so large an amount of capital—though no inconsiderable sum—was a business upon which depended the livelihood of hundreds of men and their families and the sustaining of thriving and progressive villages at many points in the Province.

"I am too loyal a Canadian" said he "to take any other view of the matter" and then he left me.

### THE EXPORT DUTY ON LOGS

INTERVIEW WITH A LEADING LUMBERMAN.

THE CANADA LUMBERMAN both in its editorial columns and also through its wandering scribe, "Eli," has a good deal to say in this number on the abolition of the duty on logs. It is the burning question in lumbering sections at the present time, and no apology is necessary for the prominence that we are giving it. Desiring to obtain the views of a well-known Canadian, one who is interested extensively both as the owner of limits and mills, your interviewer called upon Mr. John Bertram, president of the Collins Inlet Lumber Company, and one of the largest operators in the Georgian Bay region.

He was found in his office on Wellington street, and though up to the eyes in business, very cheerfully gave an audience and freely discussed the question.

"Let me say at the outset," remarked Mr. Bertram, "that there is no such quantity of logs being shipped from Canada to the States as is stated by the newspapers. The figure is placed at 160,000,000 feet. There will not be at the outside more than 80,000,000 or 100,000,000 feet shipped from Canada. I have heard names mentioned and figures given that are wide of the mark."

Do you not think, remarked the interviewer, that even though the figures may be exaggerated that sufficient will be shipped to have a hurtful effect on the lumbering industry?

"I do not," was Mr. Bertram's prompt reply. "So far as the Georgian Bay mills are concerned, I know that it is not so. When the proposition was made by the United States government to reduce the duty on manufactured lumber from \$2 to \$1, I think it was but a fair condition that we should abolish the duty on logs. Of course I should like to have seen entire free trade in lumber, and I can hardly fancy that there are two opinions among lumbermen on this point. I was in Saginaw, Mich., last week and was told of a large lumberman who purposes building a mill in Canada in order to cut his logs here. It costs \$1 a thousand to tow logs from Canada to the States, while the difference in the freight rates by vessel from the North Shore to Tonawanda, N.Y., is only 25 cents."

But is it not the case, was the enquiry, that the Emery Lumber Co., for example, have closed their mill at Midland?

"Yes," said Mr. Bertram, "but I would like to hear of any others. The Emery Lumber Co. were, with Mr. Miscampbell, owners of this mill. They are Americans, and own large mills in Michigan, and in order to keep these running they bought out Mr. Miscampbell's interest, closed down the mill in the meantime so that they could be assured of logs to keep their large mill on their own side busy."

Can you tell of any appreciable effect that the abolition of the duty is having on the Canadian lumber trade?

"What has been the cause of the depression in the lumber trade in Canada for the past few years?" said Mr. Bertram. "Why we have had no outlet for our coarser stuffs and you know we have immense quantities here. It has been a drug on the market. We could not export with \$2 export duty on this poorer stuff. We could not manufacture it into lumber for the \$2 import duty barred it there. It simply remained here doing no good to any one. I know now of even culls that are being shipped to the other side."

Do you anticipate, was asked, that in the event of the duty on logs being reimposed that the Americans, would retaliate by putting up their tariff and if so what would be the result?

"I can't speak for the American government," said

Mr. Bertram, "but it seems to me not unlikely. And if they did how would our mills fare then? We have got the logs, but the export duty would prevent shipping them as now: on the other hand no one could manufacture this coarse stuff here and ship it to the States with a practically prohibitory tariff against it. I trust that the Dominion Government are not so vacillating in their views as to make any change of policy in this respect."

"One word" at parting said Mr. Bertram, "some folks talk about the amount of money that is being taken out of the country the product of timber limits owned by Americans. In the first place these people bought their limits, have had to pay for them and surely should be allowed to realize on them in their own way. The country got the purchase money. But there are Canadians too, who are large owners of limits. Our money is locked up in these limits. As a Canadian I sell say \$200,000 of stuff which before was unsaleable, is this money going to remain idle in my hands? I have that much more money to place in circulation in our own country. There is a lot of nonsense talked on this question."

#### ANDREW MISCAMPBELL M.L.A.

ANDREW MISCAMPBELL M.L.A., for East Simcoe is a representative lumberman. His parents hail from the Green Isle, but in 1834 they came to Canada, and on 28th of June, 1848, in Simcoe County this promising legislator was born. He has quite a military record. He was engaged in the Fenian repulse as sergeant-major of the provisional battalion of companies from the north put together in Toronto. From 1864 to 1866 he was drill instructor of the volunteers of Simcoe. Eighteen years ago he went to Midland where he now lives, to take charge of the lumber business of Mr. H. H. Cook. Later he ran a saw mill on his own account, which since the new year he has sold to the Emery Lumber Co., of Michigan. At the last general election he contested East Simcoe with Hon. Charles Drury, then Minister of Agriculture, and counted the victorious candidate. He has a thorough knowledge of lumbering and as is shown by his part in the debates in the House, he has a good grasp of all public matters.

The following is an extract from his speech delivered at the last session of the Legislature during the Budget debate:

"In the estimates of the expenditures on public lands he expected to have seen a larger amount, because the timber lands were one of the greatest sources of revenue that the Province had. A short time ago, in one of the sessions of the House, the honorable leader of the opposition asked for an exploration party to see what amount of timber we had. That was a very fair request. No business man was afraid to take stock of his affairs, and they thought on the Opposition side of the House that the government should have acquiesced in this proposition. One gentleman had told them that they had timber enough to last for a century, and another member had said that the timber land and mineral resources would amount to \$200,000,000. And they said there was no danger of these becoming exhausted; just let the present system of their disposal go on. It had been stated that the prices for timber lands were lower this year on account of the depreciation in the value of lumber. True, the lumber interests were somewhat depressed. At the last sale of timber lands they had received only \$930 per square mile. At the preceding sale they had received \$2,800 a square mile. They received per mile last year about one-third what they received the year previous. Admitting that there had been a depression in the price of lumber last year, was it fair to assume that there was such a difference that timber would fall two-thirds in value per sq. mile? Was it not fair to assume that there were other reasons for this depreciation? Was not the lumber now being sold more inaccessible than that which had been sold before? Was the timber being disposed of at the present time of as good a quality as that sold in former years? When these two things were taken into consideration the cause of the depreciation would be better understood, and they

must remember that when they had received so much for the timber in the past they had sold the best land. The members of the House, who were responsible for the welfare of the Province, press upon the honorable gentlemen opposite for a judgment, as far as timber lands were concerned, similar to what they had given in regard to the mineral lands. They should withhold for the time being the timber lands. Let such a proposition be laid before the House. He would give the honorable gentlemen opposite every support for the best interests of the country. He would lift his country above his party. If he had to sink his individuality, his character, and principles for politics, he would let politics go. He hoped the Government would issue that commission and that there would be an exploration of the timber lands. By the legislation of the Federal Government a short time ago the export duty had been taken off logs, and the consequence was that large quantities of timber were being taken across the line to the other side and sent to the mills. If the lumber was of value to the people of the United States,



ANDREW MISCAMPBELL M.L.A.

it was of greater importance to Ontario to know just how much of it she had. They were told by some gentlemen that they had obtained an estimate of the value of the timber. He would like to see the estimate that the honorable gentlemen opposite were talking about. True, Col. Dennis had gone through the country and made some kind of a report, but he had never made a careful estimate. They had been told time and time again, they had heard it on different platforms, that the Opposition had never objected to a dollar being expended in the way he had been speaking of. He did not know whether exception had been taken to such an expenditure or not. One reason why they had not done so was that the matter had not become public, because it had been discussed at a committee and not on the floor of the House."

#### HOW TO PILE HARD WOOD.

TO know exactly how to pile hard woods to secure quick results and prevent checks, strains and mold is more of a science, says the *Timberman*, than most people imagine. For instance, oak, ash, hickory and other tough woods must dry very slowly, and therefore when piled must be crossed with very thin sticks, placed closely together, in order to get it dry as slowly as possible. The soft woods, like basswood, pine and poplar dry more quickly, and there is not so much danger of checking. No hardwood pile should be more than six or eight feet wide. The front part of the foundation should be at least two feet from the ground, the back about eighteen inches. A space of at least two feet should be left between the piles. Begin the pile by leaving a space between each board, and continue to do so until the top is reached. Place the cross sticks about four feet apart and directly over each other. Put the sap boards with sap down and on the outside of the pile. Cross-sticks should never be more than three inches wide and thoroughly dry, and the front sticks should be placed so as to project about an inch beyond the ends of the lumber. This allows just enough moisture to collect to prevent the stick drying too rapidly on the ends, or faster than other portions of the pile. When a pile is completed, the top should be covered in a substantial manner to protect the lumber from rain and sun. This covering should project from each end of the pile, and also over each side.

#### BRITISH COLUMBIA LETTER.

A REPLY *re* THE HASTINGS MILL—A BUDGET OF NEWS NOTES—THE EXPECTATIONS OF TRADE.

My first care in this letter is to make a short reply to "A.P." of Vancouver. The Hastings mill last year cut as near 30 millions as can be counted. Since being repaired it can cut 150 M per day, easily and pushed, 200 M. This is in 10 hours, and it can give 45 millions per annum if you multiply it by 300 days. By running nights as well, double this amount can be produced. "A.P." ought to have seen that an error, or misprint had crept in somewhere *re* value of product at \$1,750,000 and not wasted half a column of your valuable space in discussing it. The 35 millions I put down as being cut by 3 mills of the R. C. P. Mills Co. is correct. The Hastings is the fourth mill belonging to this company, and "A.P." does not seem to be aware of this.

#### NEWS NOTES.

Wm. Mackay, of Ottawa, paid a visit to this coast this month.

The Shuswap Milling Co.'s mill at Kamloops was started up this month.

The Revelstoke Lumber Co. has added new and improved machinery to their mill.

The lumber export market is still quiet on account of the scarcity of tonnage. Freights are very high for the few vessels that offer. A good local trade is being done by all the mills.

The cut for 1890 of Knight Bros.' mill at Popcum, on Fraser River, was 812 M feet of lumber, 500,000 shingles and 8,000 fruit boxes. These latter were used at Chilliwack for the packing and shipping of fruit.

Elmar Ward's shingle mill has started up again this month, and shipping to Winnipeg and the North-west has begun. He has received very flattering letters *re* the quality of his shingles and expects a good summer's trade.

Hughitt & McIntyre's new mill at Genoa, on Cowichan Bay has just been started. The capacity is 125 M per day. Six million feet are in the booms, and contracts are let for 16,000,000 feet to be delivered them this season.

Andrew McLaughlin, manager of the Pacific Lumber Co., has returned from a trip to Eastern Canada where he succeeded in getting the necessary stock for his company subscribed. Machinery, etc., will be forwarded shortly and construction will begin as soon as it arrives.

This will be a busy season in building operations in Vancouver. Among the larger works are the Bank of British Columbia building, new post office, the hotel Metropole and Y.M.C.A., and among the buildings announced for the summer are the C.P.R. general offices and the Hudson Bay Co.'s block. Nearly the whole of Water street will be built up including a block by C. G. Major, and a number of new blocks are in contemplation on Cordova street.

Several new saw mills are talked of in the Province, at Liverpool, opposite McLaren-Ross mill; at Hall's Prairie; one by Clarence Debeck, a late partner in the Brunette Saw Mill Co., on the north-west coast of the mainland, with a capacity of 100,000 feet per day; one by N. Slught & Co., late of Michigan, at Steveston, near mouth of Fraser River; one by C. L. Street & Co., at Chilliwack, now almost ready and making a specialty of box lumber. The Victoria Lumber and Manufacturing Co.'s new mill at Chemainus, began cutting early in April with a capacity of 200,000 per day. The Brunette saw mill has started again after completing some improvements and alterations. The McLaren-Ross mill is in full operation.

The cut of the Vancouver Saw Mill Co. for 1890 was 4½ million feet. The mill only ran five months or so. Extensive alterations have been made to greatly increase this output. H. G. R.

New Westminster, B.C., April 25th, 1891.

Oak timber loses about one-fifth of its weight in ordinary seasoning, and about one-third of its weight in becoming perfectly dry.



TRADE REVIEW.

Office of CANADA LUMBERMAN, April 30th, 1891.

TRADE is marked this month with a certain measure of activity consequent upon the opening of navigation. There has been more than the usual volume of shipping to Oswego, especially of common lumber. Prices are if anything on the low side, an advance of ten cents on shingles being the only deviation from those that prevailed a month since.

Local trade is somewhat slow. Whilst there are a considerable number of large contracts out for the erection of public buildings, which will make work fairly brisk, yet these are scattered over a period in some cases of several years, and the benefit is only reaped gradually.

The construction of J. R. Booth's new mill on the Chaudiere will be an event in lumbering of more than local moment. This mill, when finished, will be one of the largest and finest in Canada, and among the first in America.

The lumber shipped to the States from Ottawa and Carleton Place during the three months ending March 31st as shown by the official returns, amounted to \$393,000, as compared with \$203,000 for the similar three months last year.

Word comes from New Brunswick, through Robert Connors, the St. Frances lumberman, that the cut of the present winter on the St. John river and its tributaries will not exceed 150,000,000 feet, and unless the freshet is very heavy it is doubtful if all this comes out.

UNITED STATES.

Our lumbermen across the border are not hopeful at the opening of the season of a very brisk trade. Building has not started up with any show of activity—especially in the Eastern States. One cause of this no doubt is the anticipated strikes nearly all along the line.

FOREIGN.

The Timber Trades Journal says that much interest centred around the quantity of Canadian goods offered on the market on 15th ult. "Of these a largish line of Montmorency 3rd spruce, a good representative parcel, were keenly competed for, although the competition did not take a wide range, being confined to a few of the regular dealers on the front seats.

market price; the longer lengths, viz., 14 ft. to 16 ft., went at from 5s. to 7s. 6d. a standard more, these latter being scarce in the better class of goods. We were rather surprised to see the 3rd Saguenay, a coarse lot, making as much as £6 5s., but we suppose it was from the fact of their being 12 ft long."

Toronto, Ont.

TORONTO, April 30, 1891.

CAR OR CARGO LOTS.

Table listing lumber prices in Toronto, Ontario, including items like 1 & 1 1/2 in. Cut up and better, 1x10 & 12 dressing and better, etc.

YARD QUOTATIONS.

Table listing yard quotations for various lumber types such as Mill cull boards & scantling, Shipping cull boards, Scantling & joist, etc.

Ottawa, Ont.

OTTAWA, April 30, 1891.

Table listing lumber prices in Ottawa, Ontario, including Pine, 1st qual., 2nd, shipping culls, etc.

Montreal, Que.

MONTREAL, April 30, 1891.

Table listing lumber prices in Montreal, Quebec, including Pine, 1st qual., 2nd, shipping culls, Basswood, Oak, Walnut, etc.

Oswego, N. Y.

OSWEGO, April 30, 1891.

Table listing lumber prices in Oswego, New York, including Three uppers, Pickings, No. 1 cutting up, etc.

Siding.

Table listing siding prices, including 1 in siding, cutting up pikes & uppers, 1 in dressing, etc.

1x12 Inch.

Table listing 1x12 inch lumber prices, including 12 & 16 ft. mill run, 12 & 16 ft. No. 1 & 2, barn boards, etc.

1x10 Inch.

Table listing 1x10 inch lumber prices, including 12 & 13 ft. mill run, mill culls out, 12 & 13 ft. No. 1 culls, etc.

1-4x10 Inches.

Table listing 1-4x10 inch lumber prices, including Mill run, mill culls out, Dressing and better, etc.

1x4 Inches.

Table listing 1x4 inch lumber prices, including Mill run, mill culls out, Dressing and better, etc.

1x5 Inches.

Table listing 1x5 inch lumber prices, including 6 7 or 8, mill run, mill culls out, 6, 7 or 8, drsg & better, etc.

Shingles.

Table listing shingle prices, including XXX, 18 in pine, Clear butts, pine, 18 in, etc.

Pickets.

Table listing picket prices, including No. 1, 1 1/2 x 1 1/2, No. 1, 1 x 3, etc.

Lath.

Table listing lath prices, including No. 1, 1/2, No. 1, 1/4, No. 1, 1/2, etc.

St. John, N. B.

ST. JOHN, April, 30 1891.

Deals, Boards, Scantling, etc.

Table listing lumber prices in St. John, New Brunswick, including Spruce deals, Pine, Deal ends, Scantling, etc.

Shingles.

Table listing shingle prices, including Spruce, extra clear, No. 1 extra, etc.

Clapboards.

Table listing clapboard prices, including Pine, extra clear, 2d clears, etc.

Flooring, Dressed.

Table listing flooring prices, including 6 in., No. 1, No. 2, 4 in., No. 1, No. 2, etc.

Miscellaneous.

Table listing miscellaneous lumber prices, including Staves, Heading 17 in. per pr., 18 in., 22 in., Laths, Pickets, Railway ties, etc.

Albany, N. Y.

ALBANY, N. Y., April, 30 1891.

Hemlock.

Table listing hemlock prices, including Boards, 1x10 in. each, Joist 4x6, 2 1/2 x 4, each, Wall Strips, etc.

Pine.

Table listing pine prices, including 2 1/2 in. and up, good, 4ths, Selects, Pickings, 1 1/2 to 2 in., good, 4ths, Selects, Pickings, 1 in. good, 4ths, Selects, Pickings, Shelving boards, 12 in., and up, Dressing bds. narrow, Shipping boards, Box boards, etc.

Shingles and Lath.

Table listing shingle and lath prices, including Shingles, shaved pine, 2d quality, Sawed, extra, Sawed, clear butts, Cedar, XXX, Shingles, cedar mixed, Lath, pine, Spruce, Hemlock, etc.

Buffalo and Tonawanda, N. Y.

BUFFALO, April, 30, 1891.

Norway.

Table listing Norway lumber prices, including Clear, 1 in. & clear, Dressing, 1 to 2 in. all widths, etc.

White Pine.

Table listing white pine prices, including Up'rs, 1 1/2 in., 1/2 to 2 in., Sl'cts 1 in., 1/2 & 2 in., Fine common, 1 to 2 in. and thicker, No. 1 cuts, 1 to 2 in. and thicker, Mold strips, 1 to 2 in., etc.

Shingles.

Table listing shingle prices, including XXX, 18-in., XX, 18-in. or C. B., 16 inch Shingles, etc.

Table listing various lumber prices in Buffalo and Tonawanda, including XXX, sawed, C.B., No. 2, Thick cut, XXX cut, X cut, No. 2 cut, Fancy ends or butts, etc.

Boston, Mass.

BOSTON, April, 30, 1891.

Western Pine—by car load.

Table listing western pine prices by car load, including Uppers, 1 in., 1 1/2, 1 1/2 & 2 in., 3 & 4 in., Selects, 1 in., 1 1/2 & 2 in., 3 & 4 in., Moulding boards, 7 to 11 inch clear, 60 per cent clear, Fine common 1 inch, 1 1/2, 1 1/2 & 2 inch, etc.

Eastern Pine—Cargo or Car Load.

Table listing eastern pine prices by cargo or car load, including Nos. 1, 2 & 3, 4, 5, 6, 7, 8, 9, 10, 11, 12, 13, 14, 15, 16, 17, 18, 19, 20, 21, 22, 23, 24, 25, 26, 27, 28, 29, 30, 31, 32, 33, 34, 35, 36, 37, 38, 39, 40, 41, 42, 43, 44, 45, 46, 47, 48, 49, 50, etc.

Spruce—by Cargo.

Table listing spruce prices by cargo, including Scantling and plank, random cargoes, Yard orders, ordinary sizes, Yard orders, extra sizes, Clear floor boards, No. 2, etc.

Lath.

Table listing lath prices, including Spruce by cargo, etc.

Shingles.

Table listing shingle prices, including Spruce, 18 in. extra, Pine, No. 1, Cypress, No. 1, 18 in., etc.

## ONTARIO.

—Rafting has commenced at Morrisburg.

—Only one mill running at Midland as yet.

—Building prospects at Midland are promising.

—The two mills at Hespeler are running over time.

—Successful logging at Coldwater for Trask & Lakin.

—The mills at Burk's Falls are making ready for work.

—There is a large stock of logs in Mr. Markle's millyard, Dalrymple.

—Waubashene mills are in a good state of repairs and ready for business.

—The saw mill of Mr. Richard Olmstead, at Waters' Falls, is kept busy.

—Messrs. Ford & Co. are erecting a large planing mill at Sudbury, Ont.

—The water in the river at Young's Point has not been so high for years.

—Mr. Cullis, has floated over 300 logs down the Maitland river at Auburn.

—The circular saw mill at Hurdman's, on the Ottawa, has commenced work.

—Mr. McQuaig, Clinton, shipped 16 cars of timber the second week in April.

—Drivers are being hired on the Ottawa this spring at from \$20 to \$26 per month.

—W. J. Lackey's saw mill is in full blast and doing a good business at Cheesville.

—Mr. James A. Sharp is removing his lumber mill from Inglewood, to Sudbury.

—Mr. Playfair's mill, Sturgeon Bay, has started for the season with a large stock.

—The Parry Sound Lumber Co. are preparing their water mill for early spring trade.

—Better wages it is claimed are being paid Michigan lumbermen than those in Canada.

—Railway ties for use in Ottawa and vicinity are being floated down the Castor river.

—Mr. Aaron Stewart, of Orillia, had his hand badly cut by a saw in his mill a week since.

—Things are being made ready for the starting of James Playfair's saw mill, Sturgeon Bay.

—Mr. W. H. Leonard has sold his mill property at Hope Bay, to H. C. Rich, late of Goderich.

—J. E. Rolston's saw mills at Metcalfe are running full time again and turning out good work.

—A considerable quantity of timber has been rafted down the Scotch river at Riceville this spring.

—An enormous quantity of logs have been taken out and laid upon Commanada creek this season.

—A new planing mill is being erected in Meaford on the site of the one recently destroyed by fire.

—Shipping by barges has commenced at Ottawa, giving employment to a goodly number of men.

—Mickle & Dymont's big mill at Barrie has commenced the season's sawing. A large trade is done.

—The new saw mill at Powassan is buzzing, and a number of new houses are being built in the village.

—The Rathbun Company recently purchased 250,000 feet of lumber in the neighborhood of Calabogie.

—Mr. W. J. Fenton, Leitrim, Ottawa section is doing an extensive business in sawing logs for custom.

—Mr. Wm. Higginson, of Inkerman, has begun sawing this season's logs brought down the creek lately.

—F. J. Fox, of Wheatly, has thoroughly overhauled and repaired his saw mill and is now running steadily.

—Messrs. Cluff & Bennett of Seaforth are erecting a large new addition to their planing mill and pump factory.

—Messrs. Conroy Bros.' mills at the Deschenes, Ottawa district, are being put in order for the season's work.

—The paper and pulp manufacturers are asking the Minister of Customs to place an export duty on pulp wood.

—The McQuatt mill on the Nation managed by Mr. Toye is now in full blast, and will have a large turn out this year.

—The Rathbun Company are busily engaged peeling the poles for the new telephone line from Hastings to Peterboro'.

—The Thomson Bros., of Fort William have set up in the township the new machinery for the saw mill for Grayson Bros.

—Vansickle Bros., of Barrie, are building a new mill. Mills in this vicinity are commencing to get into active operation.

—R. Adams, of Vine, has the contract to supply 40,000 feet of lumber for summer residences along the shores of Lake Simcoe.

—The schooner *Woodduck* has undergone repairs and will be engaged during the season in the lumber trade on the Bay of Quinte.

—The saw mill at Cranbrook, Grey Co., is running full time. There is a big stock of logs in the yard. The owner, is a pusher.

—Mr. Walter James, of Cottam, is about purchasing 2,400 acres of timberland in Missouri. He is already a large holder there.

—About 300,000 feet of lumber at Midland, the property of the Ontario Lumber Company was destroyed by fire on the 8th ult. Insured.

—McLaughlin Bros., of Arnprior, have a gang of fifty-five men at work on the drive commencing at Alymer Lake on the Madawaska.

—The gangs in the lumbering shanties on the Upper Ottawa have nearly all returned home, having completed their winter's work.

—Large quantities of elm timber have recently been shipped from Craigvale to Thorold where it will be manufactured into fruit baskets.

—It is said the mills at Midland will be run only half time this summer and that the large one at Victoria Harbor will stand still for the season.

—Mr. David Gillies, lumberman, Carleton Place, states that his men had cut about 40,000 feet of logs on the Temiscamingue and the Coulonge.

—On 13th inst., Charles Edwin Grové, clerk in the Rathbun Company store, Deseronto, died of pneumonia at the age of 51 years, after an illness of eight days.

—Orr Bros., at Maidstone Cross, have their mill going in full blast now; but owing to the scarcity of snow last winter they have not a very heavy stock on hand.

—Pierce & Co. are advertising their large mills and water-power at the Chaudiere, with a large area of valuable limits, which will be put up at auction there on May 27th.

—Messrs. Gow & Hopewell are fitting up the old saw mills at Johnstone's mills, Ottawa district and will shortly begin operations as a saw mill and sash and door factory.

—The Fairview mills near Barrie have been re-built and plans are laid for a heavy summer's work. An immense stock of logs, chiefly oak, has been put into the yards.

—Some changes in the present arrangement of buildings owned by the E. B. Eddy Co'y are on the tapis. The sash factory is to be converted into a wood and paper box factory.

—The timber of Mr. Geo. Simser, of Russell, going over the dam is creating a bigger excitement in the village than a circus. A local paper says that the fair sex are much interested.

—Mr. George Rowland, who was head sawyer at the Warren mill for the last eighteen months has taken charge of a saw mill for the Georgian Bay Lumber Co., at Severn Bridge.

—The first two tows of the season arrived at Ottawa on 22nd when the tug E. B. Eddy steamed to the Chaudiere docks with three light American bottoms to load lumber for Whitehall, N. Y.

—Mr. James Holmes, of the 16th concession of Elma, the other day brought in a pine saw log to the Monkton mill, which was 12 feet long and contained 840 feet of timber. Beat it, somebody.

—The steamers Active and Hope of Landers Landing with scows are loading hay for the northern logging camps. Hay is getting scarce and is now selling at \$12.50 per ton, oats at \$35, wheat at \$32.50, and potatoes \$20.

—An average of 25 cars of elm logs arrive at Walkerville, daily, over the Lake Erie & Detroit River Railroad. The logs are dumped into the Detroit river and towed to various hoop and stave mills along the American shore.

—The Huntsville *Forester* says that Heath, Tait & Turnbull want to cut thirty million shingles this summer, and in order to accomplish this big work have arranged to put on two gangs and run night and day all summer.

—Mr. Amos Wood, who had a contract of making shingles for the Imperial Lumber Co., of Warren, has taken Joseph Vincent in as partner in the business and have increased their force to nearly double the number.

—Half a million feet of lumber belonging to three Midland firms was burned on 9th inst.

—A detachment of sixty men have left Ottawa from Bronson's limits on the Madawaska, to bring down "the drive." They are being paid a dollar a day, which is the highest wages paid at present for good hands to bring down the logs.

—Mr. Hamilton, of Fergus, has nearly 30 men engaged taking the wood out of the river. He floated down about 1,850 cords from Luther, Proton, &c., and this has to be taken out and piled up before the saw logs and they come down.

—Never before in the history of Wingham were there many saw logs in the mill yards of the town. All three of the mills are now being run at their fullest capacity. Messrs. Button & Fessant are sawing maple blocks for the old country market.

—Mr. James Sterling, of Ottawa ward, has returned home from the Michigan lumber woods, where many Canadian shantymen spent a prosperous winter. He states that good wages are being offered for the "drive," which has now commenced in that section.

—Mr. R. Smith, who used to lumber on the Petawawa, has been jobbing for the Ontario Lumber Co., at Commanda Lake during the past season, and up to the 1st of April got out 38,049 pieces, measuring 5,641,413 feet, the finest description and about the best in the market.

—Within the past eight months R. Miller, Wroxeter, has at various points on the line of the Canadian Pacific Railway loaded upwards of 140,000 railway ties, representing a total of about 700 cars, besides a quantity of other timber. Mr. Miller is now at work on the Ontario & Quebec division.

—Messrs. I. N. Kendall & Son have opened offices in Ottawa, opposite the C.P.N. wharf, as millwrights, draughtsmen and designers. Mr. I. N. Kendall, senior partner of the firm, has been in this class of business for over thirty-two years, and has built and designed most of the large saw mills in the district of Ottawa.

—The Bigelow saw mill, on Pigeon Lake, will soon have disappeared. Held by the Ontario Bank for debt, it has been disposed of bit by bit. The limits have been broken up and sold to various parties, and the engine, boiler and machinery has been purchased by Mr. Hazlitt, of Peterborough, and removed to his mills at Harwood.

—The William Hamilton Manufacturing Company, Peterborough are interesting themselves in having an American manufacturing concern establish works in Peterborough for the manufacture of shingle mill machinery. The machinery is at present manufactured by a company in the United States, where some 300 men are employed in the works. The company wish to establish a Canadian branch and will bring with them valuable patterns for which they hold the patents.

—The Manitoulin don't indulge in big egg stories. Lumber is their eggs. The boys of the T. Pickard's camps (Sudbury,) contractor for the Emery Lumber Co., have been telling of a big haul—a load of logs containing 8,253 feet (18 logs) as the largest load of logs that has ever been hauled in Canada, over an ordinary log road. The Manitoulin *Expositor* goes one better by saying there was hauled at Howry's camps a load that beats this by a dozen tons or so. The bunks on the sleigh were fourteen feet wide, and were loaded eleven tiers high. There were 110 logs, two-thirds of them 16 feet long, and averaging 12 inches in diameter. The team belongs to Howry & Sons and was driven by Bill Haner, of Manitowaning. Snow had to be shoveled into the road in places to make a track. Those who doubt this, can go into Henry Peter's studio and see a photograph of the load and count the butts. Now just hold on, you fellows from Manitowaning until we hear from the Ottawa, or say British Columbia. You never heard an egg story yet that somebody couldn't get ahead of.

—One hundred and thirty men are at present engaged in the construction of Mr. J. R. Booth's new mill at the Chaudiere. This mill when finished in July will be without exception, the largest and finest in the world. It will have the largest capacity, and the machinery will be the most modern and best adapted for turning out lumber in big quantities. The leading improvements in the mill will be the 13 new band saws introduced. The largest number of band saws used in any mill in the world at present is 10 and they are in a mill in Minnesota. These band saws set in position cost over \$5,000 each, making an expenditure for Mr. Booth on these saws alone of about \$65,000. Besides these 13 band saws there will be two twin circulars and two wicks gates used. In the past only one wicks gate has been used. The band saws are being introduced for the great saving they afford in the cutting of the lumber. Where eight boards are sawed now, nine will be sawed by the band saws. An interesting feature of new mill will be the provision made, if necessary, to save the saw dust and prevent its falling into the river. About 1,500 men will be employed by the firm this summer.

## QUEBEC.

—Messrs Willis & Co. of Londesborough, have shipped to Pointe Levi. Que., three carloads of square timber.

—Quite a large quantity of spool wood was manufactured at Murray Bay and Bay St. Paul during the winter.

—A Montreal builder, named Wm. Byrd, has been granted a settlement by creditors at 30 cents on the dollar, payments spread over twelve months and bearing interest. Liabilities are about \$15,000.

—In some parts of the Eastern Townships of Quebec cutting soft timber from which to make pulp-wood to be used as paper stock is quite an industry. At Scotstown the average shipment by rail, according to the Sherbrooke *Gazette*, is about 33 carloads per week, besides what comes into the mills at that place. The Salmon River Pulp Co. are filling up their yards with a large quantity.

## NEW BRUNSWICK.

—The Gibson mill (formerly McLaggan's) at mouth of Bartholemew River, Blackville, has commenced cutting.

—The New Brunswick mills are getting down to the season's work. The Snowball, Muirhead, Ritchie and Nelson mills have all commenced work.

—The Fredericton boom is now ready to take all lumber as fast as it comes. Compared with last year it is said the boom business will be much smaller.

—Mr. Geo. McKean purchased from W. C. Purvis, of the Purvis mill, Carleton, the entire cut of that mill for the season, in all amounting to about three million feet. The lumber is intended for shipment to European markets.

The Maritime Chemical Pulp Company's mill, of Chatham, has had its capacity doubled. Two new digesters, in which the pulp boiled in a chemical solution, are going in, and the old ones are relined with cement, lead lining having been discarded after a fair trial.

—The contract for log driving on the St. Johns, N. B. has been awarded to Mr. Fred Moore. The rates are as follows: from the head of Grand Falls, 20 cents; from the Mouth of Salmon River, 18 cents; from the boundary line on Aroostook River, 20 cents; from the mouth of Tobique River, 16 cents; from the mouth of Big Presque Isle River, 13 cents; from the mouth of Becaguimac River, 13 cents; from the Mouth of Meaduxnikeag River and all points below, 11 cents.

## BRITISH COLUMBIA.

—Mission, B. C., will have a sash and door factory running in about a week.

—The Morton mill, south of Cloverdale, anticipates a large trade in lumber and shingles this season.

—The Brunette saw mills, New Westminster, B. C. have made their largest shipment of the season, consisting of fourteen carloads.

—A boom of logs said to contain 600,000 feet of lumber was recently brought into New Westminster. The enormous boom came from the north and is one of the largest ever taken in at that port.

—Mr. E. Ward who owns the shingle mill on the North Arm New Westminster is building a tug for river work. She is 66 feet long, 16 feet beam, 6 feet depth of hold and will be fitted as a sidewheeler.

—The Dominion government is placing a considerable quantity of timber lands on the market in British Columbia. Tenders are now invited for a license to cut timber on a well wooded limit in the New Westminster district.

—The formal transfer of Hastings Saw Mills and Royal City Planing Mills in this city, to the British Columbia Mills, Timber & Trading Co., has been made. Mr. John Hendry will retain the general management of the company.

—The MacLaren-Ross Lumber Co. are starting four new logging camps on Campbell River, where they have a magnificent timber limit. The logs will be got out for the North Pacific Mill on Burrard Inlet, and the MacLaren-Ross Mill, New Westminster.

—The ship Titan, of Boston, recently cleared from Vancouver, B. C., loaded with 782,000 feet of rough lumber from the Hastings saw mill at that place bound for Wilmington, Del. The lumber is for the U. S. Navy. This shows the superior value of British Columbia lumber for use in ship building.

—The Brunette Saw Mill Co. of New Westminster, B. C. have made application to the Chief Commissioner of Lands and Works for a license to cut and carry away timber from the following described land in New Westminster District, viz: Commencing at a post on the south side of the river emptying into the head of Pitt Lake and about a 100 yards up from its mouth; thence north 40 chains, west 40 chains, north 80

chains, west 80 chains, south 80 chains. East 40 chains, South 40 chains, to shore of lake, thence following shore to point of commencement.

—A fine new tug the *Comet* for the Royal City Planing Mills, Westminster, which has been building for some time, was launched from the company's yard a few days since. She was designed by Mr. A. McNair. The dimensions are as follows; Length over all, 85 feet; breadth of beam, 16 feet; depth of hold, 7 feet. The engines are compound, 10x20, with 14 in. stroke, and were manufactured by the John Doty Company, Toronto. The addition of this fine steamer to the company's fleet gives the Royal City Mills Co. the largest number of steamers owned by any one milling establishment on the Pacific Coast. These mills are running over time to keep up with the heavy demand for their out put.

—Timber, says the B.C. *Commercial* instead of being imported in the rough log and cut up there, is now sent to England in a more and more finished state, to the saving of freight and carriage, and with greater convenience in handling and stowing. According to a circular of one of the largest houses, last year showed a great and increasing import to Great Britain of all kinds of timber ready cut, to special shapes, with a corresponding diminution in the old business in solid logs. Sawn timber in brief is rapidly gaining the ascendancy. As compared with 1889, the total imports showed a decrease of 17 per cent.; and the consumption at the same time fell off by 7 per cent.

## MANITOBA AND THE NORTHWEST.

—The indications point to an early opening of navigation in Manitoba.

—A lumber yard and planing will be started at Carberry immediately.

—J. T. Simpson, lumber, Moose Jaw, N. W. T. has assigned in trust to Herbert Crowe.

—Campbell & Stevens, lumber, Glenboro, Man., have opened a branch lumber yard at Stockton.

—Fred Robinson has sold out his interest in the Robinson Co. lumber firm of Selkirk, Manitoba. The remaining partners are offering to sell out.

—A lively logging business will be done on the Bird Tail creek in Manitoba this season. A number of men have already been engaged for log driving.

—Moore & Macdowall of Prince Albert, Sask., have commenced the shipment of lumber. The new railway gives an outlet for the great forest north of Prince Albert.

## FIRES AND CASUALTIES.

A sawyer in the Star mill, 16 con. of Grey has had his foot badly smashed.

An Indian lad named Porte employed in Dr. Sibbalds trust, near Newmarket, was crushed to death by a tree falling upon him.

Joseph Walden, a sawyer in Seiberts sawmill, Logan, near Mitchel was killed on 14th Apl. by falling against a circular saw.

Wm. Kirby, a driver for the Rathbun Company, Kingston, was thrown from his cart which passed over him, breaking his leg.

Half a million feet of lumber belonging to three Midland firms was burned on 9th ult. The Ontario Lumber Co. is the heaviest loser.

T. Sheles of the Mechanics mill, New Westminster, B. C. has had his hip seriously injured by coming in contact with a circular saw.

Patrick Malia, who is well-known in the Ottawa district as an expert hunter and bushman, has been committed by the Magistrate at Arnprior as a dangerous lunatic.

Two of Graham, Horn & Co's. workmen have been obliged to take to the Pt. Arthur hospital, one suffering from a severe cut in the head caused by a falling tree striking him, and the other from a cut in the foot from an axe.

While Mr. Copley, of Kirkton, was driving through the woods on 9th ult on a load of logs with his 8 year old son the latter fell off, and a log following struck him on the head, fracturing his skull he only lived a short time.

At Langille's sawmill, Mahone Bay, N. S. on 10th ult Mrs. Joseph Ernest found her husband's body in a standing position in the dam when she went to give him his dinner. His head was only a few inches under the water. The supposition is he was on a small raft getting a log to haul up and the raft parted and he went down feet first.



Chas. Henderson, government bush ranger, has been spending a little time in the Muskoka region.

Mr. J. Cromwell Cox, of the lumber firm of R. M. Cox & Son, Liverpool, England, is in Canada on lumbering business.

Walter James, of Cottam, has left for Tennessee to look after his track of timber, some 1,600 acres.

Mr. James Angus, formerly of Warren, Ont., has left to take charge of a large American saw mill.

Mr. Snowball, New Brunswick's well-known lumberman is expected home from England early this month.

Mr. C. A. C. Bruce, of the Maritime Chemical Pulp Company left Chatham N. B. for Europe 24th ult.

Mr. E. H. Cooke for eight years in the cedar mill department of the Rathbun company at Deseronto has removed to Toronto.

—Lieut.-Col. Forsyth well-known among the lumbering men of Ottawa and Hull, has been sworn in Collector of Customs at Quebec.

Mr. Edward Ryan, sawfiler at Bronson & Weston's mill, and for many years well-known at the Chaudiere, died during the month after a lingering illness.

Mr. Wm. McKay, the well-known Ottawa lumberman, accompanied by Mrs. McKay, son and daughter, recently visited Manitoba, the Pacific coast and Minnesota.

Mr. E. Walter Rathbun, of Deseronto, Ont., is home from his California trip. He was deeply impressed by the illimitable resources of that part of the continent.

Mr. Leo Gregory, head sawyer at the Royal City Mills, New Westminster, B.C., is visiting friends in the old country. He will call at London, Eng., Madrid, Paris, Rome, and Jerusalem, not forgetting to visit his aged parents at Bilbao, in northern Spain, before returning home. He will be away about four months.

On Sunday April 12th inst., Mr. Henry Witbeck, a well-known Chicago lumberman, counted a victim to la grippe. He was a public spirited citizen, serving at one time in the city council.

Mr. C. D. Pickles, of Messrs. Pickles & Mills, dealers in lumber, Annapolis, N.S., has recently visited the West India Islands and the Guianas, making a careful survey of the lumber markets.

THE LUMBERMAN was favored with a call during the month from Mr. W. C. Penoyer, of the well-known lumber manufacturing firm of Penoyer Bros., Au Sable, Mich. He reports the lumber business prosperous in that state.

We were pleased to have a call during the month from lumberer Geo. Fulton, of Clifford. He reports trade quiet, but has on hand a good stock of logs. He added, "I am very much pleased with THE LUMBERMAN and get considerable information as well as news from it." And backed up his appreciation by promptly renewing his subscription.

Mr. Robert H. Klock, one of Canada's well known lumbermen, died at his residence in Aylmer, during the past month. For some time he had been suffering from erysipelas. Deceased was a native of Alymer, born 9th Jan., 1823. He owned large limits on the Ottawa river, and carried on extensive operations on the Black river, and in connection with his limits there, erected mills at Mattawa. He was a Conservative and a Presbyterian.

Professor Brown, late of Guelph, now Professor of Agriculture in Western Australia, has been making a tour of inspection of the timber wealth of the lately delimited province, and as a result he reports to the Government that the timber ready for cutting is worth not less than \$500,000,000. Much of this timber is of the most valuable kind in size, strength, and indistructability by rot or borers.

Mr. E. B. Ackerman of Durry, B.C. is dead. The deceased gentleman, father of Messrs. O. B. and T. Ackerman the well known contractors and mill owners, was a native of Erie, Pa., having been born there in 1821. He went to British Columbia about eight years ago and settled on a farm at Upper Sumas, remaining there until last September, when failing health decided him to make Westminster his home. The deceased leaves a wife and six children, four of whom reside in British Columbia and were present at his bedside when death closed his eyes.



WANTED AND FOR SALE.

Advertisements will be inserted in this department at the rate of 15 cents per line each insertion. When four or more consecutive insertions are ordered a discount of 25 per cent. will be allowed. This notice shows the width of the line, and is set in Nonpareil type. Advertisements must be received not later than the 27th of each month to insure insertion in the following issue.

WANTED—TO BUY.

GOOD Canadian Timber Limits and Georgian Bay saw logs. Address, BEN BIRDSALL, Whitney Building, Detroit, Mich.

WANTED.

EMPLOYMENT or partnership in lumber business, by man of large experience in manufacturing and shipping. Ready by 15th May. High references. Address, R. B., CANADA LUMBERMAN, Toronto.

HARDWOOD lumber, bought, sold or received on consignment, TUCKER DAVID, lumber commission merchant, 202 Eleventh Ave., N.Y.

WANTED IN 1891.

ANY QUANTITY OF CEDAR TELEGRAPH POLES at shipping points. Terms cash. Apply to J. HARRISON HARVEY, Cobocok, Ont., purchaser for H. D. McCAFFREY, Engineer and Contractor of Telegraph lines, Oswego, N.Y.

RAILS AND CARS FOR SALE.

Light Steel Rails for Tramways; good order. Cars for lumber, cheap.

JOHN I. GARTSHORE, 49 Front St. West, Toronto.

WANTED.

QUEBEC BIRCH—Those who can furnish choice lumber are invited to correspond with

JOHN S. MASON & CO., 240 Eleventh Avenue, New York City.

FOR SALE—Planing mill in Toronto, forty five feet frontage, one hundred and ten ft. deep. One third three stories, balance two stories. Fifty horse power Wheelock engine, sixty five horse power Steel Boiler, also the latest improved machinery. Address, JNO. WOOD & SONS, Cor Front and Erin Sts., Toronto.

EMPLOYMENT WANTED by an experienced Lumber Inspector and shipper, acquainted with American and English markets. Can bring small but increasing business. References produced on application. Address, H. M. W., LUMBERMAN office.

HIGH PAY TO BARK PEELERS

WANTED, May 15, 1891, 750 competent Bark Peelers for this season's work, at \$1.75 a day and board. Address or call on J. L. SNYDER, Leetonia, Tioga Co., Pa., U. S.

MORTGAGE SALE

—OF VALUABLE—

Timber Limits

—AND—

SAW MILL PROPERTY

IN THE TOWNSHIP OF BEXLEY, CO. OF VICTORIA.

Under and by virtue of the power of sale contained in a certain mortgage from George A. Wagar to the vendors, bearing date the 14th July, 1890, default having been made in payment thereof, will be sold by public auction, at

Chirpaw's Hotel, at Victoria Road.

—ON—

WEDNESDAY, MAY 13, 1891,

At 1 o'clock, p.m., 1371 acres of land, being composed of the northerly 37 acres and the easterly 91 acres of the southerly 103 acres of lot 4, in concession 1; lots 4, 5 and 7, in concession 2; northerly half of lot 6 and the northerly 40 acres of lot 7, in concession 3; lot 6, easterly half of lot 7 and lot 12, in concession 4; and the west half of lot 12, in concession 8, all in the township of Bexley. The timber is pine, hemlock, cedar and hardwood.

The Mill is situate on lot 6, in concession 4, about one mile from Corson's Siding, on the Cobocok Branch of the Midland Railway. The mill is 40x84 feet and 30x50 feet, with two good boilers and engine (75 horse power), and all machinery required in a first-class mill for cutting lumber, shingles and lath. The mill and machinery are in good order and nearly new. There is a frame boarding house and stable on the property in close proximity to the mill.

The above property will be first offered en bloc; if not sold en bloc, the lots will be put up and offered separately. This is a first-class opportunity for contractors and builders or for any parties engaged in the lumbering trade.

TERMS—One-tenth of the purchase money on the day of sale, and the balance in thirty days thereafter; or other approved security will be taken for the purchase money, bearing interest at six per cent per annum.

For further particulars and conditions of sale apply at the Law Office of BAYLY & BAYLY, MR. W. H. DECATER, Vendors' Solicitors, Corson's Siding, London, Ont.

J. J. TURNER,

Sail, Tent and Awning Maker,

251 GEORGE AND 154 KING STREETS,

PETERBOROUGH.

Canoe, Yacht and Boat Sails made to order. Perfect Fits guaranteed.

Every description of Lumbermen's Supplies and Waterproof Clothing.

Timber Limits

BRITISH COLUMBIA.

FOR SALE!

\$5,000 to \$50,000 of shares in a Stock Company owning and operating Saw and Planing Mills Sash and Door Factory, etc. Valuable Timber Limits in connection. This is an exceptionally good chance to make money.

Address—

LIMITS.

Care of CANADIAN LUMBERMAN.



SEALED TENDERS, addressed to the undersigned, and endorsed "Tender for supplying Coal for the Public Buildings, Ottawa," will be received at this office until TUESDAY, 5TH MAY, at noon.

Specifications can be seen and forms of Tender obtained on and after Tuesday, 28th instant, at this office, where all necessary information can be had on application; also at the office of James Nelson, Architect, Montreal, and D. B. Dick, Architect Toronto.

Each tender must be accompanied by an accepted bank cheque for the sum of \$500, made payable to the order of the Honourable the Minister of Public Works, which will be forfeited if the party decline to enter into a contract when called upon to do so, or if he fail to complete the work contracted for. If the tender be not accepted, the cheque will be returned.

The Department will not be bound to accept the lowest or any tender.

By Order, E. F. E. Roy, Secretary,

Department of Public Works, Ottawa, 20th April, 1891.



TENDERS.

SEALED TENDERS addressed to the undersigned and endorsed "Tender for Indian Supplies," will be received at this office up to noon on SATURDAY, 9th May, 1891, for the delivery of Indian Supplies during the fiscal year ending 30th June, 1892, consisting of Flour, Beef, Bacon, Groceries, Ammunition, Twine, Agricultural Implements, Tools, &c., duty paid, at various points in Manitoba and the North-West Territories.

Forms of tender, containing full particulars relative to the supplies required, dates of delivery &c., may be had by applying to the undersigned, or to the Indian Commissioner at Regina, or to the Indian Office, Winnipeg.

Parties may tender for each description of goods (or for any portion of each description of goods) separately, or for all the goods called for in the Schedules, and the Department reserves to itself the right to reject the whole or any part of a tender.

Each tender must be accompanied by an accepted Cheque in favor of the Superintendent General of Indian Affairs, on a Canadian Bank, for at least five per cent. of the amount of the tender, which will be forfeited if the party tendering declines to enter into a contract based on such tender when called upon to do so, or if he fails to complete the work contracted for. If the tender be not accepted, the cheque will be returned, and if a contract be entered into for a part only of the supplies tendered for an accepted cheque for five per cent. of the amount of the contract may be substituted for that which accompanied the tender; the contract security cheque will be retained by the Department until the end of the fiscal year.

Each tender must, in addition to the signature of the tenderer, be signed by two sureties acceptable to the Department, for the proper performance of the contract based on his tender.

This advertisement is not to be inserted by any newspaper without the authority of the Queen's Printer, and no claim for payment by any newspaper not having had such authority will be admitted.

L. VANKOUGHNET,

Deputy of the Superintendent-General of Indian Affairs.

Department of Indian Affairs, Ottawa, March, 1891.

Advertisement for THE BALL ELECTRIC LIGHT CO. MANUFACTURERS OF ELECTRIC LIGHTING APPARATUS. 57, ADELAIDE ST. W. TORONTO ONT.

CHICAGO, MILWAUKEE AND ST. PAUL RAILWAY.

Electric Lighted and Steam Heated Vestibuled Trains, with Westinghouse Air Signals, daily, between Chicago, St. Paul and Minneapolis, daily.

Electric Lighted and Steam Heated Vestibuled Trains between Chicago, Council Bluffs and Omaha, daily.

Through Vestibuled Sleeping cars daily, between Chicago, Butte, Tacoma, Seattle, and Portland, Oregon.

Solid Trains between Chicago and principal points in Northern Wisconsin and the Peninsula of Michigan.

Daily Trains between St. Paul, Minneapolis and Kansas City via the Hedrick Route.

Through Sleeping Cars, daily, between St. Louis, St. Paul and Minneapolis.

The finest Dining Cars in the World.

The best Sleeping cars. Electric Reading Lamps in Berths.

6,100 miles of road in Illinois, Wisconsin, Northern Michigan, Iowa, Minnesota, Missouri, South Dakota and North Dakota.

Everything First-Class.

First-Class People patronize First-Class Lines.

Ticket Agents everywhere sell Tickets over the Chicago, Milwaukee and St. Paul Railway.

WILLIAM FOSTER

Lumber & Commission Merchant

Receiver and forwarder of

LUMBER, LATH & SHINGLES

Correspondence Solicited.

OWEN SOUND, ONT.

Investment Bonds.

THE DOMINION SAFE DEPOSIT WAREHOUSING & LOAN CO., LTD

Head Office—The Canadian Bank of Commerce Building, King St. W., Toronto.

CAPITAL, ONE MILLION DOLLARS.

DIRECTORS.

- W. D. Matthews, Esq., President. Henry W. Darling, Esq., Vice-Pres.
John I. Davidson, Esq. S. F. McKinnon, Esq. G. B. Smith, Esq. M.P.P.
H. W. Nelson, Esq. J. P. Clark, Esq. J. H. Starr, Esq.
M. C. Cameron, Esq. Robert Kilgour, Esq. Alexander Nairn, Esq.
Thomas McCracken, Esq. Robert Davies, Esq. Eugene O'Keefe, Esq.
Aaron Ross, Esq.

This Company is now issuing \$100, \$200, \$300, \$400 and \$500 investments in bonds, payable in five, ten and fifteen years from date of issue, with participation in profits, affording all the advantages of compound interest accumulations on small sums of money. These bonds are the obligations of this Company and are specially protected by a sinking fund, invested in first-class real estate mortgages. They are plain definite contracts, subject to no contingencies whatever, are non-forfeitable after one annual payment, with values definitely stated thereon. For a small outlay they secure a fixed and generous return.

To bondholders who complete their contracts the Company guarantee compound interest at the rate of Four Per Cent. Per Annum.

The Company is prepared to receive applications from reliable agents at all points where it is not already represented.

WM. KERR, Manager

The Safe Deposit Vaults of the company cannot be surpassed for absolute security. Call and examine or write for circular.

Advertisement for WATERLOUS ENGINE WORKS. 80 H.P. CUT OFF COUPLING. GRIP Pulleys & Cut off Couplings. 10x3 TO 10x30 SPLIT OR SOLID GUARANTEED. AFTER USING YOU WONDER HOW YOU MANAGED WITHOUT IT. WATERLOUS ENGINE WORKS. Brantford, Can.

Advertisement for TORONTO Lithographing Co. LITHOGRAPHERS & ENGRAVERS. TORONTO.

**A. M. DODGE & CO.**

MANUFACTURERS of and Wholesale Dealers in all kinds of Lumber, Lath and Shingles. Tonawanda, N. Y.

**COWPER & GREGORY.**

RECEIVERS and Forwarders of Lumber, Lath, Shingles, &c. Unexcelled facilities for shipping by canal or rail. Tonawanda, N. Y.

**CHEESMAN DODGE**

TIMBER and Lumber Merchants. Ship and Boat stock, Railroad Ties, &c. Office, 16 West Seneca Street, Buffalo.

**EMMET FLEMING**

INSPECTOR and Commission dealer in Lumber. Office, 251 Louisiana Street, Buffalo, N. Y.

**LAYCOCK LUMBER CO.**

MANUFACTURERS of Pine, Hemlock and Oak Timber up to 35 feet in length. Saw Mills: Ackley, Pa., Black Rock, N. Y., Gravenhurst, Ont. Office, corner Main and Seneca Sts., Buffalo, N. Y.

**J. & T. CHARLTON**

WHOLESALE dealers in Masts and Spars, Canada Round Pine, &c. Tonawanda, N. Y.

**WILLARD W. BROWN.**

202 Main Street, Buffalo, handles all kinds of Hard Woods.

**A. P. & W. E. KELLEY CO.**

WHOLESALE Lumber dealers. Yards at Tonawanda and Chicago. Correspondence invited.

**C. P. HAZARD.**

WHOLESALE dealer in Lumber, Shingles, Lath and Fence Posts. Correspondence invited from the Canadian trade. No 92 River Street, Buffalo, N. Y.

**L. A. KELSEY LUMBER CO., (Ltd.)**

MANUFACTURERS and dealers in Hardwood Lumber of all kinds. Describe stock and write for prices. Office Tonawanda, N. Y.

**BOVEE & HOWDEN**

MANUFACTURERS and Wholesale dealers in Hard and Soft Wood Lumber. Holders of Canadian stocks are invited to write for quotations. Offices at Tonawanda and Le Roy, N. Y.

**THE TONAWANDA LUMBER CO.**

MILLS at East Tawas, Mich.; office 106 Main Street, opposite N. Y. C. and H. R. R. Station, North Tonawanda, N. Y.

# Cash for Lumber

W. N. McEachren & Co.

Wholesale dealers in all kinds of

# HARDWOOD LUMBER

NO. 3 DOCK  
TORONTO

WRITE US FOR PRICES AND SIZES TO CUT.

WE PAY CASH WHEN LOADED ON CARS.

HERBERT G. ROSS.

Box 273.

REGINALD C. BLAKER.

## N. G. ROSS & CO.

Real Estate, Fire and Life Insurance, Shipping and General Commission Agents.

Timber Limits and Farming Lands a Specialty.

A.B.C. Code, Cable address, "Ross."

NEW WESTMINSTER. - - - B. C.

CORRESPONDENCE SOLICITED.

# LUMBER

## TRUCK \* WHEELS.

## The Montreal \*

## \* Car Wheel Co.

MANUFACTURERS OF

### CHARCOAL IRON CHILLED

## RAILROAD WHEELS

Offices: New York Life Insurance Building, Montreal.

Works: Lachine, Quebec.

WE make a Specialty of Wheels suitable for the requirements of Lumbermen and Street Car Service, and can supply them Bored, Finished and Balanced.

CORRESPONDENCE SOLICITED

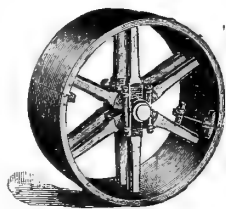

Mens ha Hickory Plies

We make the only hardwood bent rim spoke arm split pulley, only small split pulley, only wooden hangers in the market. Send for discounts & circulars.

Menasha Wood Split Pulley Co. MENASHA, WISCONSIN.

### THE MONARCH BOILER

(PATENTED) AND HERCULES ENGINE.



Guaranteed to Saw Lumber Perfectly Smooth and Even in thickness.

Portable from 6 to 70 horse power. Surpass portable steam power heretofore produced for strength, durability, compactness, and the ease with which they can be moved. The 70 horse power can be taken over the roughest roads, or into the forest, and set up as easily and quickly as an ordinary 20 horse power portable engine, and as firm as a brick-set stationary engine. Engines and boilers of every size and description. Rotary Saw Mills, Shingle and Lath machines, Law Grinders, Planers, etc. Mill machinery and supplies of every description. Every boiler insured against explosion by the Boiler Insurance & Inspection Co. of Canada. Write for circulars.

A. ROBB & SONS, Amherst Foundry and Machine works. ESTABLISHED OVER 40 YEARS.

DALTON McCARTHY, President. A. ECKARDT, Secretary. JOHN McGREGOR, Manager.

## Toronto and Midland Mf'g Co.

(INCORPORATED.)

## Wholesale \* Lumber \* Dealers

AND MANUFACTURERS OF

### DRESSED LUMBER, FLOORING

Ceiling, Sheeting, Siding, Shelving, Mouldings of all Descriptions.

Office and Yard:

FOOT OF SPADINA AVE., - TORONTO.

Planing Mills: MIDLAND, ONT.

## PORTER, ROBERTSON & CO.

STOCKS  
STRIPS  
SIDINGS  
BILLSTUFF

WHOLESALE

# LUMBER

DEALERS

HARDWOODS  
HEMLOCK  
SHINGLES  
LATH, ETC.

Millichamp's Buildings,

35 \* Adelaide \* Street \* East,  
TORONTO.

YARD: NORTHERN DOCK, FOOT OF BATHURST STREET.

## NAPANEE CEMENT COMPANY

(LIMITED)

— MANUFACTURERS OF —

## Hydraulic Cement

PARTICULARLY adapted for Dams, Smoke Stacks, Foundations, Culverts, Cisterns, Cellars, etc.

ENDORSED BY LEADING RAILWAYS AND CONTRACTORS.

### ROACH \* LIME,

For Building, Plastering, Gas Purifying, Paper Making, &c.

## THE RATHBUN COMPANY,

DESERONTO, ONT.,

MANUFACTURERS OF

## \* TERRA \* COTTA \* FIRE-PROOFING \*

For Use in Old and New Buildings.

Endorsed by Leading Architects. Absolutely Fire-proof. About as Cheap as Wood or Brick. Weight One-Third that of Brick. Does not Crack on application of Heat or Water.

Deadens Noise. Gives Warmth in Winter; Coolness in Summer.

## Galt \* Machine \* Knife \* Works.



### MACHINE KNIVES

OF EVERY DESCRIPTION FOR

Planing, Moulding & Stave Cutting.

SEND FOR PRICE LIST

PETER HAY, - - - GALT, ONT.

# The Only Successful Kiln for Drying Oak and other Hardwoods

**"THE ANDREWS"**

NEW LUMBER

## DRY-KILN

Its remarkable efficiency depends upon its peculiar mode of applying heat to, and eliminating moisture from, the air used in drying. We use no costly fan, engine or other device that requires constant attention, nor do we waste heat by a special chimney. The air circulates through the lumber, and the moisture absorbed from it is extracted from the air by natural methods. You can not afford to be without it.

Our Process Duplicates Nature.

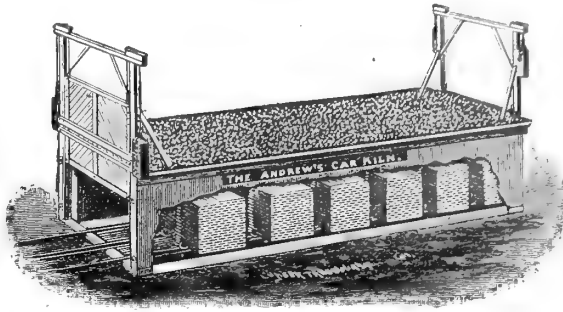

Outside View of the Andrews Kiln.

The following firms have recently purchased Andrews Kilns:  
Estey Manufacturing Co.  
East Shore Lumber Co.  
Universal Tripod Co.  
Grand Rapids School Furniture Co.  
New England Furniture Co.  
Milwaukee Chair Co.  
Oshkosh Furniture Co.  
Skandia Furniture Co.  
Story & Clark Organ Co.  
Rock Falls Manufacturing Co.  
Courey & Birely Table Co.  
Southern Spring Bed Co.  
Sidney School Furniture Co., Sidney, Ohio  
New Richmond Church Furniture Co., N. Richmond, O.

## A. H. Andrews & Co., Proprietors and Manufacturers

215, 217, 219, 221 Wabash Ave., CHICAGO, ILL.

## The Casselman Lumber Co.

CASSELMAN, ONT. Successors to FLATT & BRADLEY.

ESPECIAL GOOD FACILITIES FOR SHIPPING.  
HEMLOCK BILL STUFF OF EXCELLENT QUALITY.  
ALSO MANUFACTURERS OF  
PINE, SPRUCE, ASH, MAPLE AND OTHER HARDWOODS.  
CORRESPONDENCE SOLICITED.

J. W. MAITLAND  
H. RIXON

J. G. AINSLIE  
W. STODART

## Maitland, Rixon & Co.,

Owen Sound, Ont.

## Saw Millers and Lumber Dealers

All kinds of Building Material kept in stock.

WE MAKE A SPECIALTY OF  
LONG BILL STUFF IN ROCK ELM, PINE, CEDAR AND HEMLOCK  
QUOTATIONS FURNISHED ON APPLICATION.

GEO. HASTINGS.

JOHN GRAY.

H. HANCOCK.

## GEO. HASTINGS & CO.

Lumber Merchants

TRUST BUILDING CHAMBERS,  
Cor. Yonge and Colborne Streets.

TORONTO.

All Kinds of Pine and Hardwood Lumber.

BILL STUFF CUT TO ORDER A SPECIALTY.

## DONOGH & OLIVER,

Wholesale Dealers in

## LUMBER

OFFICE:

Nos. 213, 214 and 215, Board of Trade Building,

COR. YONGE AND FRONT STS.

TORONTO, ONT.

## THE "LEADER"

The Finest Tempered, Fastest Cutting  
and Best Saw made on the Continent.



Manufactured of Triple Refined Silver Steel,  
Rolled specially for us from Superior Ingots.

THE KING OF CROSS-CUT SAWS

R. H. SMITH COMPANY, LTD., ST. CATHARINES, ONT.

Sole Manufacturers.



The Gold Medal,  
Toronto, 1883

# WOOD WORKING MACHINERY

The Gold Medal,  
London, 1883

## For Door, Sash, Blind and Furniture Factories

- |                |                       |                  |
|----------------|-----------------------|------------------|
| PLANERS.       | BAND SAWS.            | BUZZ PLANERS.    |
| MOULDERS.      | BAND RE-SAWS.         | MORTICERS.       |
| TENONERS.      | PANEL RAISERS.        | BLIND MACHINERY. |
| SHAPERS.       | DOVETAILERS.          | BAND SAW FILER.  |
| RIP SAWS.      | JOINTERS.             | BAND SAW SETTER. |
| SAND PAPERERS. | DOUBLE SPINDLE BORER. | ETC., ETC.       |

# The Galt Bros. Co., Limited, GALT, ONTARIO.

Write for Circulars  
and Prices.

Correspondence  
Solicited.

## Rhodes' Improved Swage for Circular and Gang Saws.

≡PATENTED JULY 2, 1889.≡

THE MOST PERFECT MACHINE FOR THE PURPOSE EVER INTRODUCED.

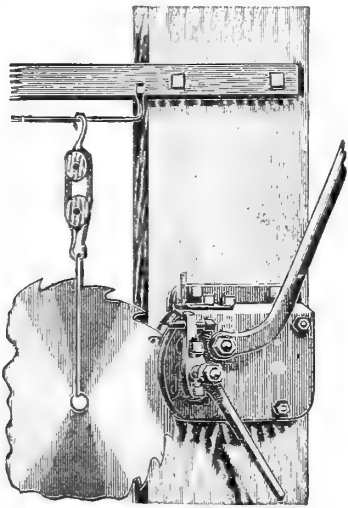

SWAGE IN OPERATION.

It will swage the hardest as well as the softest saws. Never pulls the points of the teeth off, as the swaging is done by direct and steady pressure, and not by rolling pressure.

Swaging done with this machine will stand longer than when swaged with any other machine or by hand.

It makes the swage the heaviest on the under side of the tooth, and leaves the face of the tooth perfectly straight.

It does not shorten the tooth as done by upsetting. It has a positive clamp so a saw cannot slip while being swaged, therefore every tooth is an exact duplicate of the other.

Corners never drop off if swaged with this machine, as it does not injure the steel, therefore the teeth can all be kept of a length.

It is very simply constructed: nothing to break or wear out. Easily adjusted. Any ordinary man can swage a circular saw in from 10 to 12 minutes. Is thoroughly constructed of the best material, all the parts requiring it are made of steel of the best quality. Every swage is thoroughly tested before leaving the shop.

We positively guarantee the swage to do all we claim for it in this circular.

Full and complete instructions for adjusting and operating accompany the swage.

SEND FOR PRICE LIST OF

RHODES' IMPROVED

Automatic Band Saw Swages, Circular Saw Swages, Gang Saw Swages, Shingle Saw Swages.

—MANUFACTURED EXCLUSIVELY BY—

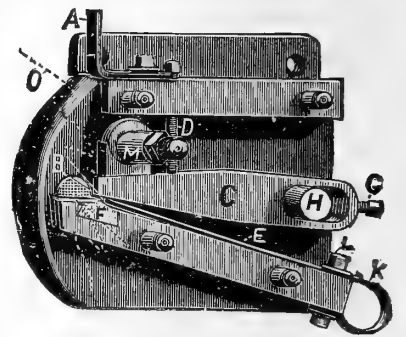

SECTIONAL VIEW.

P. O. BOX 430.

## Palmiter, Empey & Co., Galt, Ont.

Established 1849.

Incorporated 1884.



We use nothing but W. J. & Sons' English Steel in our saws and the name speaks for itself.

# Detroit Saw Works

MANUFACTURERS OF

## Circular, Gang, Mulay, Drag and Cross-Cut Saws.

MOLDING AND PLANING KNIVES,

*French Band Saws, Emery Wheels and General Mill Supplies.*

**66, 68, 70 and 72 Fort St. East, DETROIT, MICH.**

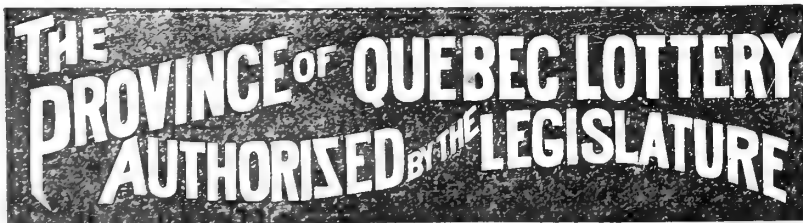

MONTHLY DRAWINGS ON

2nd Wednesday of Every Month

S. E. LEFEBVRE, Manager.

Head Office—81 ST. JAMES STREET, - MONTREAL.

PATENTED 5TH MARCH, 1877.

## PARKER & EVANS,

Sole Proprietors of the

FAMOUS INTERNATIONAL

## BOILER - FLUID - COMPOUND.

This compound will save its cost many times in one year by saving fuel.

It eradicates scale, and when the Boiler is once Clean a very small quantity keeps it clean and free from all incrustation. One fourth the dose will prevent a new Boiler from scaling so long as it is used regularly.

Contains no Caustic Soda, and is the only matter yet known that will not injure metals in any way, and emits a clear pure steam.

30 WILLIAM STREET, - MONTREAL.

# Friction Pulley Board.

The Best Materials ever used  
for Frictions of all  
\* kinds \*

MANUFACTURED BY

Asbestos  
Mill  
Board.

The **DOMINION LEATHER BOARD COMPANY,**  
Montreal, Quebec.

Steam  
Packing.

SAMPLES FURNISHED.

PLEASE MENTION THIS PAPER.

CORRESPONDENCE SOLICITED.

# THE DODGE PATENT WOOD SPLIT PULLEY CO.

MAUFACTURERS OF

Pulleys of every description and style in stock and made to order.

Prices lower than any other first-class Pulley.

**Patent  
Split  
Belt  
Pulleys**

Every pully guaranteed strong enough for heaviest Mill Work, and to give more power with same belt than any other pulley made.

Send for Catalogue and discounts.

**Dodge Wood Split Pulley Co.,** City Office, 83 King St., W.  
**TORONTO.**

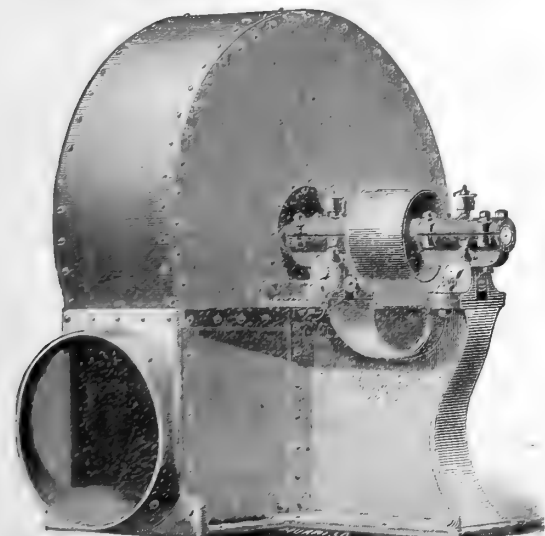

## THE STURTEVANT STEEL PLATE PLANING MILL EXHAUSTERS.

PROGRESSIVE LUMBER DRY KILNS, HEATING AND VENTILATING APPARATUS  
FOR ALL CLASSES OF BUILDINGS.

**B. F. STURTEVANT CO., BOSTON, MASS., U. S. A.**

**BRANCHES:** 91 LIBERTY ST., NEW YORK  
16 S. CANAL ST., CHICAGO.  
135 N THIRD ST., PHILADELPHIA.

**A. R. WILLIAMS, Soho Machine Works, Toronto, Ont.,**  
GENERAL AGENT FOR THE DOMINION.

# BOILERS, BURNERS, TANKS,

IN ALL VARIETIES.

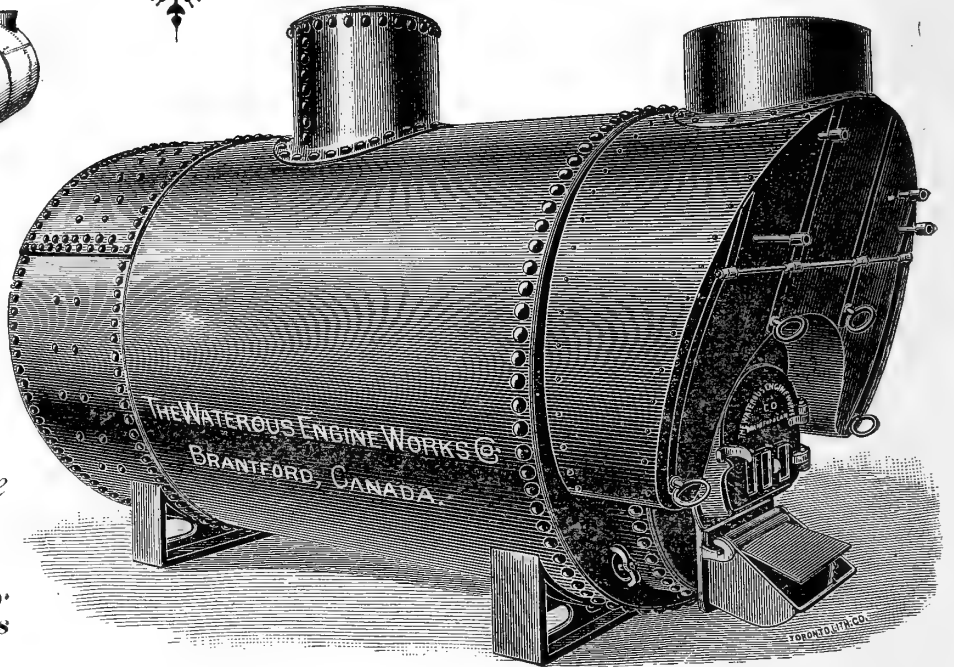
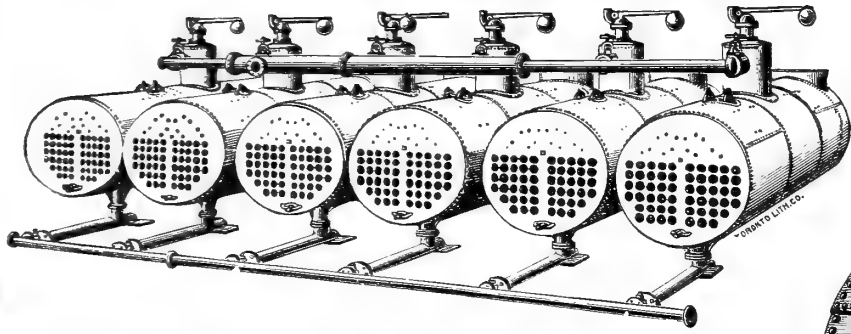
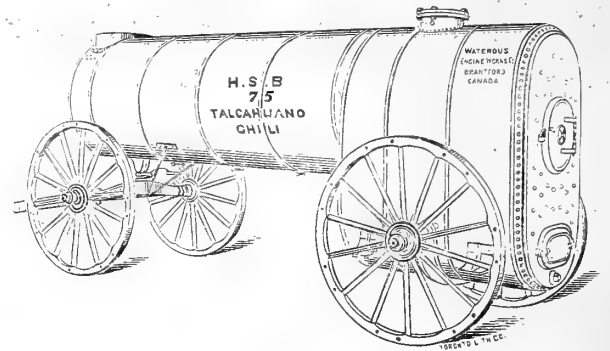
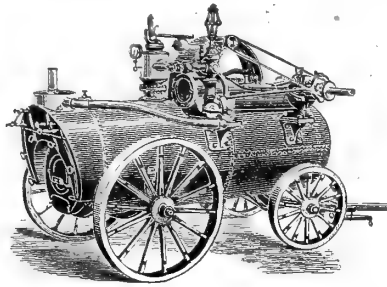

## BOILERS

UP TO SIXTEEN FEET LONG

*Can be made with but one sheet on the bottom, thus avoiding seams over the fire.*

*Boilers built to purchaser's plans when desired.*

*We guarantee our marine work to pass Gov't inspection.*

*Our prices are as low as they can be made, consistent with good material and work.*

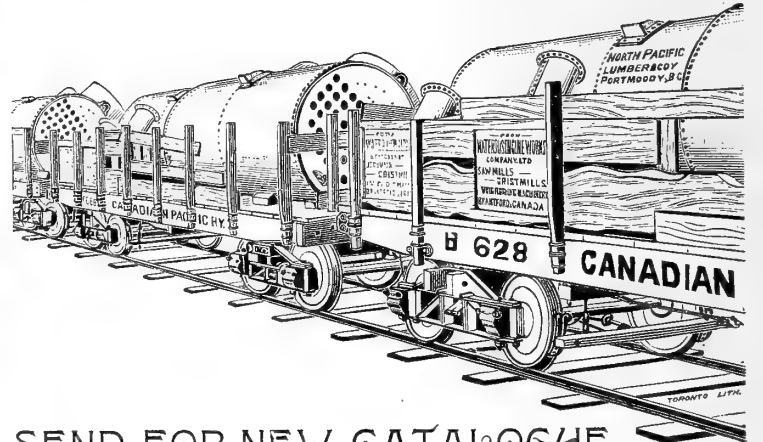
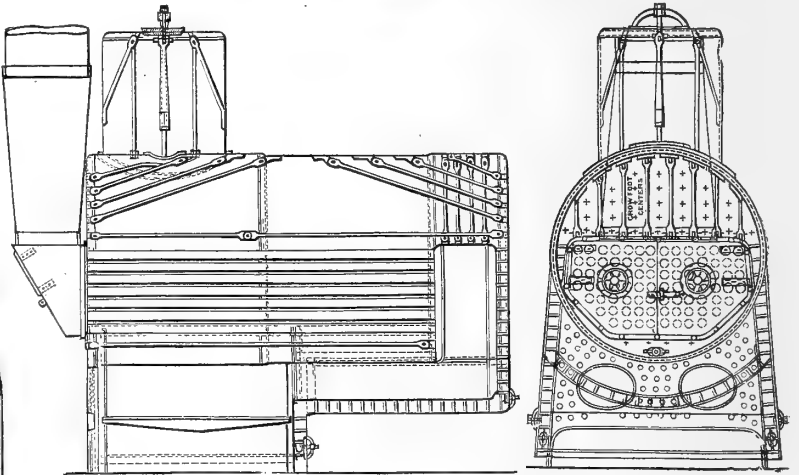
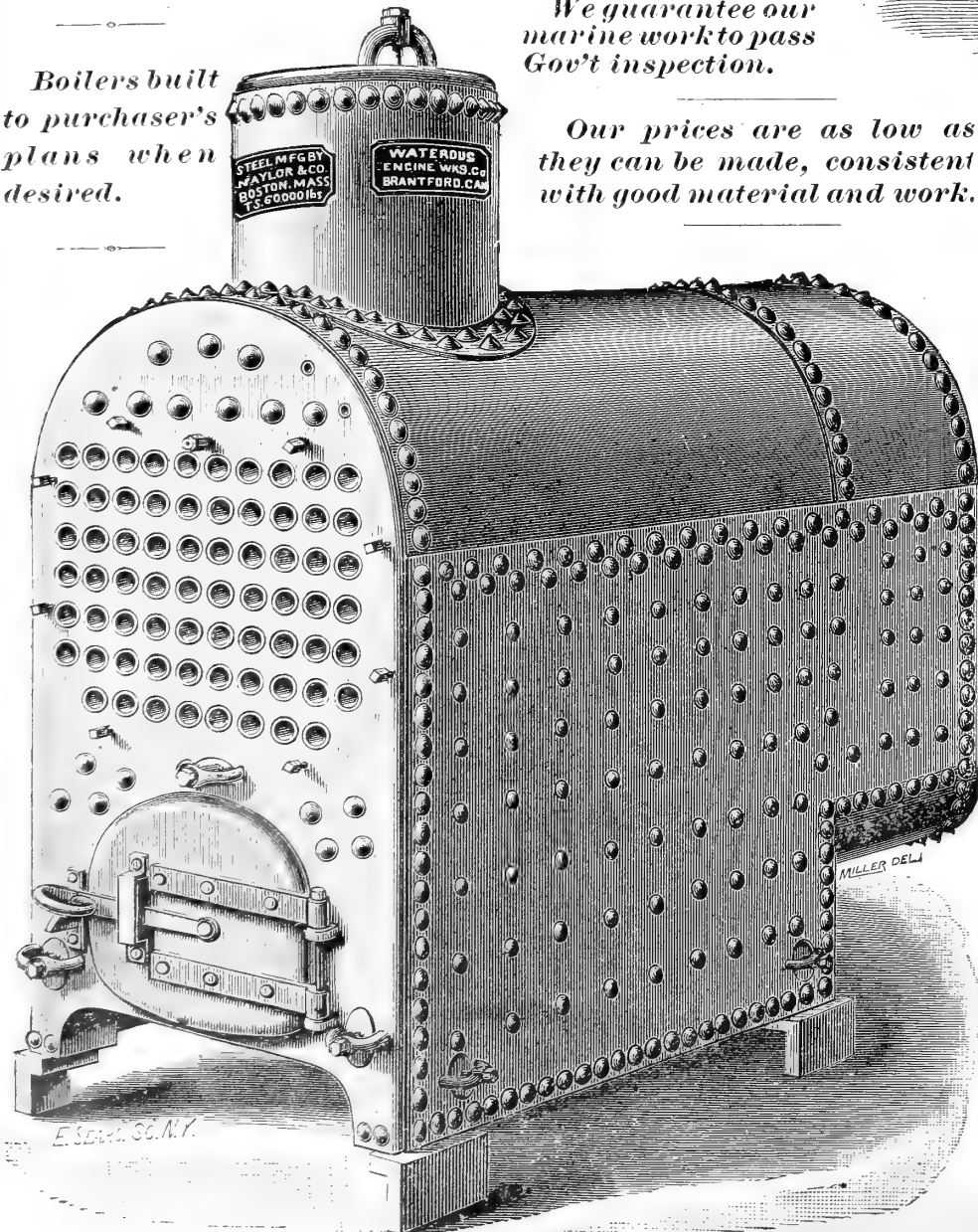

SEND FOR NEW CATALOGUE

And ask for estimates on any boiler work required.

**Waterous** ENGINE WORKS CO. LTD., **Brantford,** CANADA.



# "DO YOU LACK STEAM? WE CAN HELP YOU!"

## THE GORDON PATENT HOLLOW BLAST GRATE.



A HOLLOW BLAST GRATE.

A new and novel application of a principle centuries old. Step into the nearest blacksmith shop and see

it in operation, on a small scale.

The **Hollow Blast Grate** supplies the furnace fire with a **blast of Hot Air** sufficient at all times to insure the rapid and perfect combustion of fuel of every sort.

It is the only successful appliance for generating steam from such fuel as the **SAWDUST** and refuse from hemlock, cypress and hard wood timber or from spent tan bark.

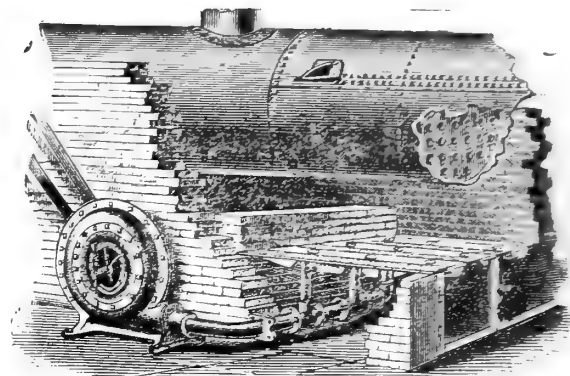

FURNACE FITTED WITH HOLLOW BLAST GRATES AND APPARATUS

**N. B.**—Regardless of the character of your fuel, we can greatly increase the volume of steam generated by your boilers. It Costs you nothing to try them. We guarantee satisfaction or no sale.

### RECENT TESTIMONIALS

JOHN ORM, Pres. S. H. LANGSTAFF, Vice-Pres. GEO. LANGSTAFF, Sec'y. H. W. RANKIN, Treas.  
LANGSTAFF-ORM MAN'G CO.

Manufacturers of Lumber, Sash, Doors, Blinds, Etc. Long Steamboat Lumber a Specialty.  
PADUCAH, KY., March 7th, 1891.

The Gordon Hollow Blast Grate Co., Greenville, Mich.

DEAR SIRS,—Enclosed find our cheque to cover amount due you for the Hollow Blast Grate Bars purchased from you some time ago. We have given the Bars a thorough test and are very much pleased with them; we find them to be all you claim.  
Yours truly,  
LANGSTAFF-ORM MF'G CO

JNO. N. PHARR. F. B. WILLIAMS.  
PHARR & WILLIAMS.

Band Sawed Cypress Lumber. Daily capacity, 100,000 feet. Extra Wide Lumber and Tank Stock a Specialty. 50 Million of Logs on hand. 6 Million Feet of Lumber in stock. W. U. Telegraph in office.

C. S. BURT, Esq., PATTERSON, LA., March 9th, 1891.  
Baton Rouge, La.

Dear Sir—Our Grate Bars (Hollow Blast Grates) are now making us all the steam we wish. We had some doubt as to our boilers having sufficient capacity to furnish steam for our engine as they have only 100 horse power while our engine has 250; but we are now making more steam than we can use with cypress saw dust and refuse from our mill. Any one can figure the capacity of the boilers for themselves. There are four of them 32 feet long by 42 inches diameter, each with two flues 15 inches diameter. Our engine is 24x30. Anyone who is short of steam can not do better than to put in the Blast Grate bars. Yours very truly,  
PHARR & WILLIAMS.

J. T. LIDDLE LUMBER CO.

Lumber. Merchandise. One Mile from Mississippi City, L. & N. Railroad.

HANDBORO, MISS., March 9th, 1891.

To THE GORDON HOLLOW BLAST GRATE CO., Greenville, Mich.

GENTS.—We are now running our mill with the Hollow Blast Grates and instead of requiring two mule carts to haul away the saw dust, we now consume nearly all, giving us much better steam than we were forced to make it with wood and the small quantity of saw dust we could burn. We are satisfied that every mill man burning wood alone, or wishing to utilize the dust, bark, etc., for fuel will find by test, that the Blast Grates will reduce the labor and expense of steaming by one half.  
Respectfully yours,  
J. T. LIDDLE LUMBER CO.

BRINKLEY CAR WORKS AND MANUFACTURING CO.

Yellow Pine and Oak Lumber.

BRINKEY, ARK., Feb. 7th, 1891.

To THE GORDON HOLLOW BLAST GRATE CO., Greenville, Mich.

GENTLEMEN:—We have your favor of the 5th, and beg to say in replying thereto, that the Hollow Blast Grates you put in for us are a splendid success, and we are more than pleased with them; by using them we are able to make enough steam to run our plant without having to put in another large boiler. We recommend them very highly. Enclosed find acceptance in settlement of account.

BRINKLEY CAR WORKS & MF'G CO.

H. H. MYERS, Sec. and Treas.

THE WOLVERINE LUMBER CO.,

CAIRO, ILL., Feb. 8th, 1891.

To THE GORDON HOLLOW BLAST GRATE CO., Greenville, Mich.

GENTLEMEN:—Yours of the 14th ult. at hand. In reply will say that we had grates placed and ready for use about the middle of December last, and by January 1st were

fully convinced that they were exactly what we needed. We could not think of trying to run without them for ten times their cost. We are running two band mills in green oak right out of the water, and are burning all our saw dust, leaving none to be carted away. The burning of the saw dust, with your grates, makes a very hot fire and keeps up steam splendidly without the use of any other fuel, excepting a very few slabs. We consider your grates to be what any saw mill requires. As for us, we would not think of trying to run without them. Yours truly,  
THE WOLVERINE LUMBER CO.  
A. E. STEVENSON, Supt.

SILAS KILBOURN & CO.,

Fish and Syrup Packages, Cider Kegs and Jelly Pails.

GRAND HAVEN, MICH., Feb. 20th, 1891.

To THE GORDON HOLLOW BLAST GRATE CO., Greenville, Mich.

GENTLEMEN:—Enclosed find check in payment for bill of Grates, etc. Please acknowledge receipt of same and oblige. The Grates are doing all you claimed, and more. Will save amount of your bill in better power and fuel in a short time. Before we put them in we had to buy a great many cords of dry slabs each year; we now burn nothing but saw dust and waste from factory, and have much better steam than before. We drive blower with a small "Dake" engine, which we think an improvement over connection with factory power. Yours truly,  
SILAS KILBOURN & CO.

DECATUR LUMBER CO.

All Kinds of Rough and Dressed Lumber.

DECATUR, ALA., Feb. 12th, 1891.

To THE GORDON HOLLOW BLAST GRATE CO., Greenville, Mich.

GENTLEMEN:—Your Blast Grates are all that you claimed for them, and are very satisfactory.

DECATUR LUMBER CO.

A. W. LEE & CO.,

Oak, Pine and Hemlock Lumber.

BELSENA MILLS, PA., Feb. 12th, 1891.

THE GORDON HOLLOW BLAST GRATE CO., Greenville, Mich.

GENTLEMEN:—Enclosed find our check in settlement of account. The apparatus is in and does its work well. It is a decided improvement over the old. We recommend its use. Yours truly,  
A. W. LEE & Co

C. C. MENGEL, JR., Pres.,  
Louisville, Ky.

A. W. WRIGHT, Vice-Pres.,  
Alma, Mich.

C. R. MENGEL, Sec.-Treas.,  
Louisville, Ky.

C. C. MENGEL JR. & BRO. CO.

Louisville, Ky.

Manufacturers of Poplar and Hardwood Lumber.

Mills: Trimble, Tenn.

Oakton, Ky.

Tipton, Tenn.

Boston, Ky.

Office of

Jas. R. DELVECCHIO, Supt.

Trimble Mill.

The Trimble & Kenton Railway.

is owned and operated

by this Company.

TRIMBLE TENN., March 3rd, 1891.

GORDON HOLLOW BLAST GRATE CO., Greenville, Mich.

DEAR SIR:—Please find enclosed check in payment of our account. Your grate bars have given us perfect satisfaction, and a reference to our records shows that in one month previous to the time we put them in, we had 21 stops for steam, aggregating 6 hours and 9 minutes, or an average of 17 minutes to the stop. Since putting in your bars, on the same fuel in one month, we have had only 6 stops for steam, aggregating 1 hour and 22 minutes, or an average of 13 minutes to the stop. Before introducing your system steam was very seldom up to the limit and the machinery would be continually dragging; since your bars have been put in, if steam gets low the cause is in the fireman alone. Yours truly,  
C. C. MENGEL JR. & BRO. CO.  
JAMES R. DELVECCHIO, Supt.

# The Gordon Hollow Blast Grate Co., Greenville, Mich.

Sole Proprietors of the Gordon Patents for the United States and Canada.

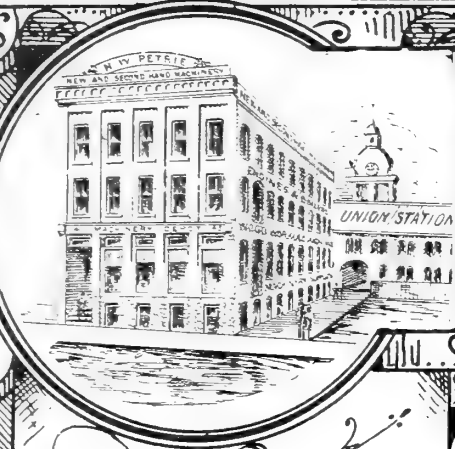

# PETRIE'S MACHINERY DEPOT.

*Special Bargains  
this month.*

- One New Eclipse planer and Moulder, Galt make.
- Champion Planer, Moulder and Moulder, nearly new.
- Little Giant Planer, Moulder and Moulder, price \$200.
- 24-inch Planer and Moulder, Dundas make.
- New Pony Planers and Moulders, only \$1.75.
- 24-inch Pony Planer, Frank & Co. make.
- 27-inch Double Surfacers, revolving bed—Cowan & Co. make.
- No. 3 Revolving Bed planer, Cowan & Co. make.
- 24-inch Pony planer, Ross make, Buffalo.
- No. 4 Pony planer, McKechnie & Bertram, builders.
- Economist planer, moulder and moulder, Frank & Co. make.
- 24-inch wood frame planer, Kennedy & Sons make.
- 1 planing machine knife grinder.
- 24-inch wood frame surface planer, cheap.
- 24-inch surface planer, Rogers make, Norwich, Conn.
- 23-inch surface planer, American build.
- 21-inch wood frame planer, Kennedy & Sons build.
- 22-inch surface planer, McKechnie & Bertram build.
- 22-inch wood frame planer, in good order.
- 20-inch wood frame planer in good order.
- 12-inch diagonal buzz planer, new, Galt make.
- Daniels planer, R. Ball & Co. make.
- Moulder, Kennedy & Sons' make, Owen Sound.
- Beading and moulding attachment for planer; Ross make, Buffalo.
- No. 2 Three-sided moulding machine, Galt make.
- 3 Sided Moulder, made by Rogers, Connecticut.
- New power morticers—Galt make.
- One chair or upright boring machine.
- Iron top shaper—Goldie & McCulloch make Galt.
- Centennial top jig saw—Goldie & McCulloch builders.
- Double cope tenoning machine—Dundas make.
- New 36-inch resaw—Galt make—also band resaw machines.
- Tenoning machine—without copes—price only \$60.
- Wood turning lathes—several sizes.
- New combination saw table—all iron and steel.
- Improved power rod feed machine—MacGregor, Gourlay & Co., Galt, builders.
- No. 1 shaper—all iron—Goldie & McCulloch build.
- Improved saw arbors—all sizes—Galt make; large stock.
- One improved iron frame swing saw—new; Buffalo make.
- Sand paperers—new and second hand.
- New dovetailing machine—Tyrell's patent.
- New 30 and 36-inch band saws—Galt make.
- New 25-inch band saw, Cant Bros. & Co. make, Galt.
- Four pair scroll saws and three foot power; good order.
- Three blind slot turners, all Galt make.
- Dodge wood split pulleys at maker's prices; quick delivery.
- Foot and hand mitreing machines, latest design.
- Foot and hand wiring machine, Galt make.

*Send for our Illustrated Catalogue  
New and Second Hand  
Machinery.*

## H. W. PETRIE

DEALER IN

### New and Second Hand Machinery

OF ALL KINDS.

*141 and 145 Front Street West,  
Toronto, Ont.*

My new and commodious warehouse is fast filling up in every department and new lines are being continually added. Parties requiring Engines, Boilers, Iron or Wood Tools, in fact, anything in the shape of Machinery, will do well to give me a call before placing their orders.

#### REMEMBER THE PLACE

*Immediately adjoining the Union Station.*

# H. W. PETRIE PROPRIETOR 141 TO 145 FRONT ST. WEST TORONTO, ONT.

C. C. CLEVELAND. G. F. CLEVELAND.  
**J. L. GOODHUE & CO.,**  
 MANUFACTURERS OF  
**Leather Belting**  
 AND  
**Lace Leather.**  
 DANVILLE - - QUEBEC.

THIS SPACE FOR SALE.

RAILROAD, BANK & OFFICE  
**DESKS**  
 TEES & CO.,  
 300 ST. JAMES STREET, MONTREAL.

**STORAGE OF LUMBER.**  
 We are prepared to receive any quantity of Lumber for storage. Freight and money will be advanced on same. Also, Warehouse Receipts issued, which can be hypothecated to banks and others. Storage charges easy. For further particulars apply to  
**W. LEAK & CO.**  
 Lumber, Coal and Wood.  
 DUNDAS STREET, - - TORONTO.

**GOODDAY, BENSON & CO.**  
 QUEBEC, P. Q.  
**General Lumber & Timber Merchants.**  
 Correspondence is solicited from parties having choice stocks of Hardwood and Pine to offer, either in the log or in sawn lumber.

**JOHN BERTRAM & SONS,**  
 CANADA • TOOL • WORKS  
 DUNDAS, ONTARIO.  
 MANUFACTURERS OF  
**WOOD-WORKING MACHINERY**  
 MACHINE TOOLS, ETC.  
 Write for Prices and Catalogues

**Packing Cases in Shooks.**  
 Any Saw mill in Canada able to undertake large orders for Case Boards is requested to communicate with  
**W. & C. PANTIN**  
 147 Upper Thames Street,  
 LONDON, - - - - - ENG.

**GEO. CORMACK**  
 Wholesale and Retail Dealer in  
*All kinds of LUMBER.*  
 Lumber Shipped to all parts by Rail or Vessel.  
 WHITBY, - - - - - ONTARIO

William Hamilton, Water Works Department, Pumping House, Superintendent, Toronto, Jan. 6th, 1891.  
 ALONZO W. SPOONER, Port Hope.

**A. T. ANDERSON & CO.,**  
 CONTRACTORS FOR  
**ELECTRICAL AND GENERAL MACHINERY.**

Dear Sir,—I am pleased to say that after nearly three years constant use, day and night, on our largest engine your COPPERINE has stood its work well. I have not had to renew any of the heavy bearings yet, so I consider that speaks for itself. I am pleased to recommend it to any one in need of metal to stand heavy work.  
 I remain, yours truly,  
**J. C. FERGUSON, Chief Engineer,**  
 Toronto Water Works.

Complete instalations of steam and Hydraulic Power, Electric Light and Power Plants, Wiring and Construction for Arc and Incandescent Lighting, Agents for the celebrated "C. & C." Electric Motors.  
 75 Adelaide Street East,  
 Toronto, Ont., Canada.  
 Estimates furnished and every information cheerfully given to intending purchasers.  
 N. B.—Only first-class work on which a full guarantee will be given.

**THE RATHBUN COMPANY,**  
 DESERONTO, - - ONTARIO,  
 MANUFACTURERS OF  
**Doors, Sash, Blinds, Stairs**  
 AND ALL KINDS OF WOODEN HOUSE FINISHING MATERIALS.  
**CEDAR OIL FOR PURGING BOILERS.**  
 CORRESPONDENCE SOLICITED

**The American Lumber Yard**  
**HAMBURG, GERMANY,**  
 Offers the best facilities for Yarding and Selling all kinds of  
**American Wood Goods.**  
 Address: ROSENBACHER & CO., BANKERS, Hamburg. CARL GARTNER, Agent, Hamburg.

**ROBIN & SADLER**  
 MANUFACTURERS OF  
**Leather Belting**

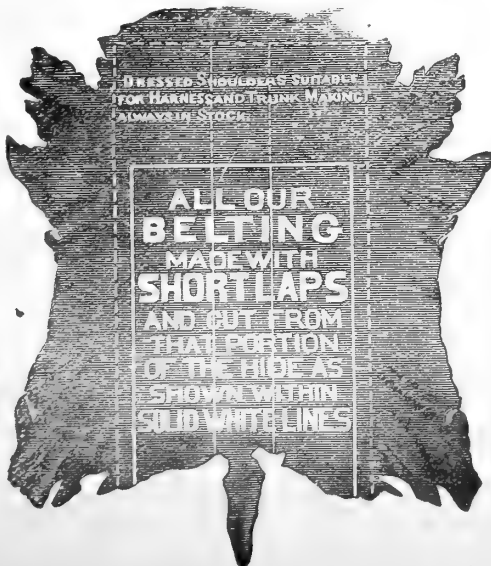

DEALERS IN  
**Lace Leather**  
 Cotton and  
**Gandy Belting**  
 2518, 2520 and 2522 Notre Dame St. MONTREAL.  
 129 Bay Street, TORONTO.



TAPER TOOTH.



TELEPHONE 5120.

**Burns & Thomas**



MANUFACTURERS OF

All Kinds of  
**CIRCULAR AND LONG Saws**

LANCE TOOTH.



WORKS AT PARKDALE.

TORONTO.

**TO MILL OWNERS, MANUFACTURERS AND ALL WHO ARE USING**

# Leather \* Belting

IF YOU WANT BELTING

*Which will Run Straight on the Pulleys,  
Which is Thoroughly Well Stretched,  
Which will not Tear at the Lace Holes,  
Which will give Complete Satisfaction,*

— SEND TO —

## F. E. DIXON & Co.

MANUFACTURERS OF

**PATENT LAP-JOINT STAR RIVET  
\* LEATHER \* BELTING \***  
*70 King Street East, Toronto.*

Sole Agents in Canada for the

## CELEBRATED PHOENIX OIL

**The Only Perfect Belt Dressing.**

All our Belting is sold at the Canadian price list. Please compare before purchasing. Send for Discounts and our Pamphlet on Belting.

TORONTO AGENCY OF

### The Rathbun Co.

ARE OPEN TO PURCHASE  
**OAK, ASH, BIRCH,  
BASSWOOD  
AND  
GOOD PINE LUMBER  
CEDAR AND PINE  
SHINGLES**

Manufacturers having such for sale are invited to communicate with

**T. W. WALKER, Agent  
TORONTO**

Office, Cor. Spadina Ave. & Front St.



### SCRIBNER'S LUMBER AND LOG BOOK

Over One Million Sold.

**M**OST complete book of its kind ever published. Gives measurement of all kinds of Lumber, Logs, Planks, Scantling; cubical contents of square and round Timber; hints to lumber dealers; wood measure; speed of circular saws; care of saws; cord-wood tables; felling trees; growth of trees; land measure; wages, rent, board, interest, stave and heading bolts, etc. Standard book throughout the United States and Canada. Get the new illustrated edition of 1882. Ask your book-seller for it. Send post-paid for 35 cents.

**GEO. W. FISHER,**  
Box 238, Rochester, N. Y.  
or A. G. MORTIMER,  
Toronto, Ontario.

## WICKES BROS., Saginaw, Mich.

MANUFACTURERS OF

### GANGS, ENGINES AND BOILERS.

The accompanying cut represents our new No. 3 Complete Iron Frame Gang Mill especially designed to meet the demand for a smaller type of mill. The strongest and most durable for high speed and thin saws. Write for further particulars,

Southern Agents,  
**McARDLE & SINCLAIR,**  
50 & 52 Barronne St  
New Orleans, La.

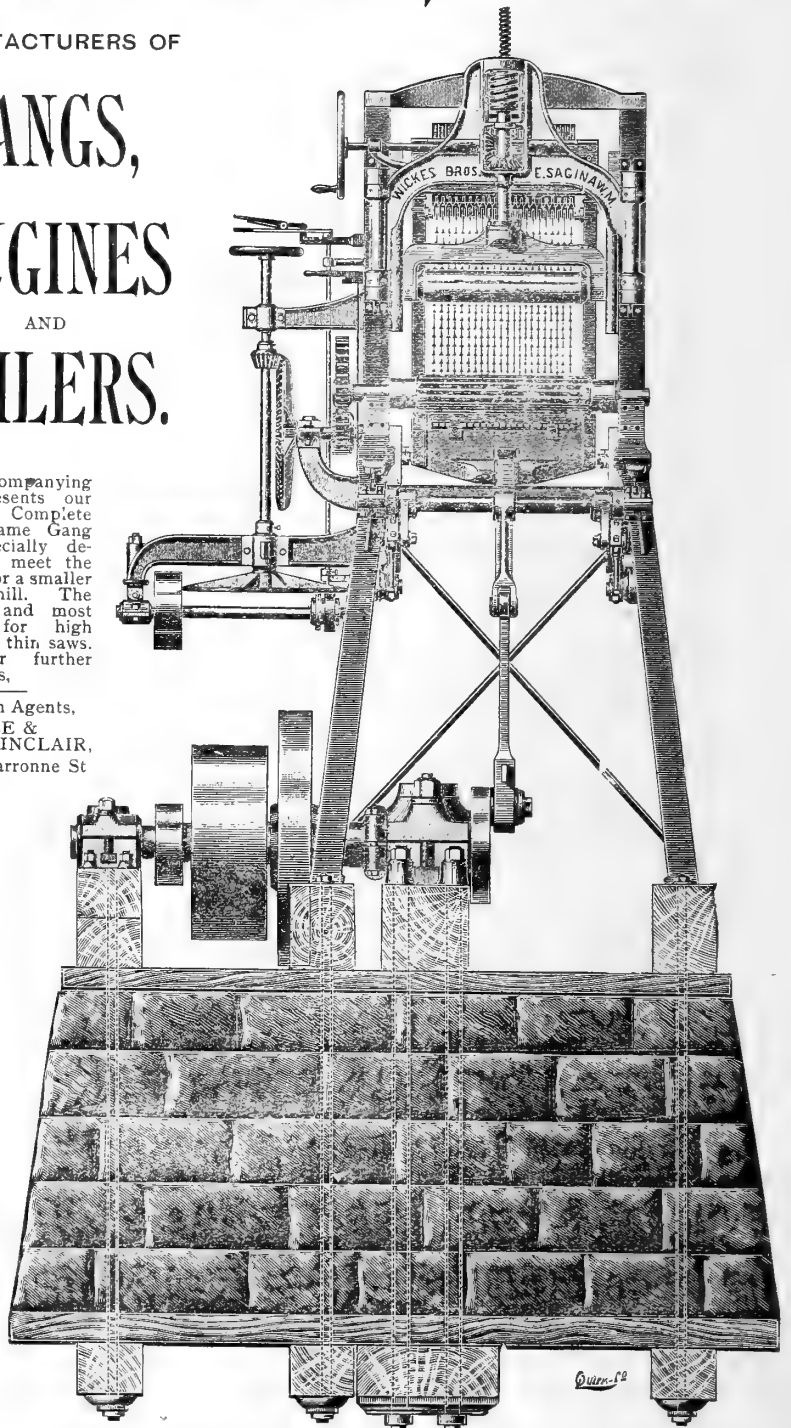

## Fawcett & Co.

### MERCHANT \* TAILORS,

*269 Queen St. E., Opp. Seaton St., Toronto.*

First-Class Goods and Trimmings. Workmanship and Fit Guaranteed.  
All Orders Punctually Executed.

# THE CANADA LUMBERMAN.

VOLUME XII }  
NUMBER 6 }

TORONTO, ONT., JUNE, 1891.

## AN ANCIENT WATER ELEVATOR.

IN Egypt and other countries where irrigation is practiced to a greater extent than elsewhere, the inventive mind has been alert for centuries, contriving devices of various kinds for elevating water. Some of these are so simple that they must have been obvious, while others show an amount of inventive genius worthy of our own century; in fact, as is well known, the fundamental principles of hydraulics were discovered ages since, and some of the early machines have never been materially changed or improved upon.

The Egyptian shadoof is a form of water elevator that has been in use from time immemorial, not only in Egypt, but almost all over the world. A device fully as simple as this, but not so old, is a gutter, which was made both single and double. It consisted of a trough pivoted at one end above the level of the water, the free end being alternately dipped in the water and raised, so as to cause it to discharge into a sluice leading away from the machine.

The pendulum water elevator shown in the engraving is a curious modification of the swinging gutter. A number of gutters arranged in two series are secured to opposite sides of a swinging frame, each series of gutters being arranged on a zig-zag line, and the two series of gutters are oppositely arranged with respect to each other, so that while one end of the lower gutter dips in the water, the lower gutter of the other series discharges into the next gutter above, and a flap valve retains the water while the device is swung in an opposite direction. In this manner the water is advanced step by step at each oscillation, until it is finally discharged into the sluice, which carries it away for use. Each of the gutters is provided with a valve, which retains the water as it moves forward and upward.

## ABOUT CIRCULAR SAWS.

EVERY saw-mill man knows that one of the most difficult and trying operations to which circular saws are put is that of log cutting, working up the rough timber into lumber. But not all sawyers are as familiar with the conditions which govern the operation of the circular saw as they should be.

These are the only tools used in cutting and dressing lumber that within themselves have certain inherent conditions to govern their speed, and a knowledge of this is an important part of a sawyer's ability and education.

A great deal of course, depends upon the material and manner in which the saw is made, whether it has been hammered "tight" or "slack" on the periphery. Assuming that on account of the centrifugal forces the steel is stretched from the eye of the saw towards its periphery, a great deal would depend upon the condition of the saw at the beginning. A saw that is hammered loose at its periphery can be operated at a much higher speed than one that is tight or stretched.

In explaining this, let us suppose that a saw is started up and gradually increased in speed. For a time, and up to a certain limit, according to the above conditions, the stiffness or rigidity of the blade will be increased. Above this limit it begins to diminish, and at a very high velocity the plate becomes limber and pliant as a

piece of paper, and if the speed is kept up, the periphery of the saw will assume an undulatory or wavy motion.

When in this condition it is as sensitive to pressure on its side as if it were made of a sheet of paper.

This, while it may form an interesting experiment, is also valuable in the consideration of the subject of speed for such tools. It shows beyond a doubt that there is a specific speed at which saws should be run to do work to the best advantage and within the limits of safety and economy.

Sawmill men as a rule are not sufficiently familiar with such matters, and only consider the subject with relation to the amount of production. There is an important matter for careful study in the manipulation of saws, and a chance for the exercise of good judg-

were the only correct thing not long since in furniture, especially for large dining tables, pianos, etc. Then came in the era of imitations of tropical woods by tricks of staining and painting; these soon deservedly lost caste. Quite recently a sensible revolution in favor of our native woods has taken place. Beginning with Black Walnut and going on to Cherry, Maple, Ash, White Oak, and even Chestnut, the native woods that are capable of receiving and retaining high polish are coming into favor for the finest furniture and inside finish. Even the most costly pianos that are given the best place in show windows and warerooms are now cased in native woods.

Among the more notable uses, to which Cypress wood could be profitably adapted, is that of boat building. The British Columbia cypress possesses

in a remarkable degree the qualities of lightness with extreme strength, pliability and elasticity, and the quality of keeping its form when bent to shape in planks. Its lightness surpasses that of the finest white spruce, and for tenacious strength it rivals Ontario hickory. In color the wood is a handsome straw color, very attractive in appearance. For boat building nothing better could be possibly obtained, as craft constructed of this timber would combine extreme lightness with extreme strength, the great desiderata with oarsmen. Great forests of this fine timber exist on the north coast of British Columbia about 200 miles up, and there are also large patches of it in the lower Fraser valley.

The silver maple is widely distributed in Eastern America; it is found in the north from the valley of the St. John's River in New Brunswick to southern Ontario, and extends southward to western Florida, and westward to eastern Dakota, Nebraska, Kansas and the Indian Territory. It is not found very near the Atlantic coast or in the high Appalachian Mountains. It is very common, however, west of the Mountains throughout the Mississippi valley, where it is one of the largest and most generally distributed of the river trees. The silver maple is often called the soft maple, probably to the brittleness of its slender branches. It has been cultivated in Europe since 1725, but does not flourish there so well as on the banks of its native streams, but better there than many of our American trees.

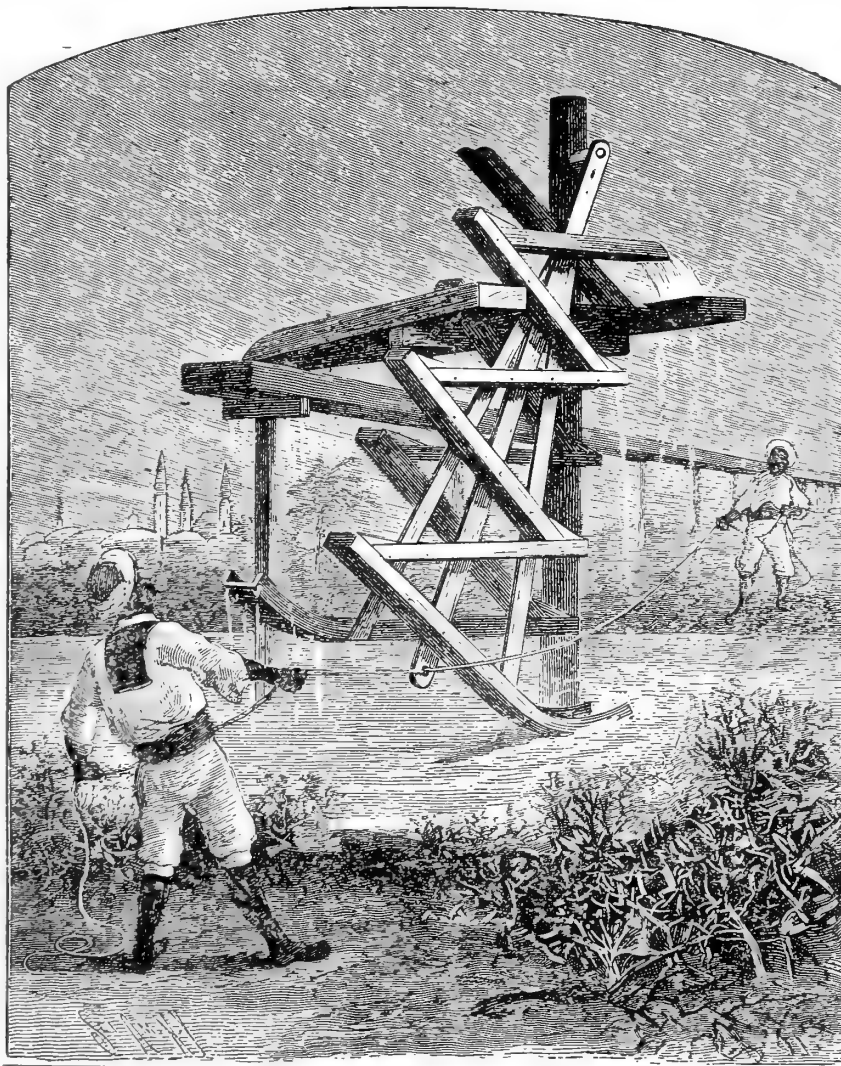

AN ANCIENT WATER ELEVATOR.

ment in regulating their speed for the different classes of work to which they are put.

## CONCERNING VARIOUS WOODS.

ELM is likely to come to the front for many uses for which Oak has been considered the only wear. Nothing is so good for hubs, for pie plates, baskets and butter packages for retail trade. Its veneers properly finished, would be beautiful for inside work. Its rapid growth up to a certain size would make it a valuable means of utilizing much rough land.

Natural laws that demand something new will always be in force, and this is illustrated in the change in popular taste with reference to our native Hardwoods. Tropical woods—Mahogany, Rosewood and Ebony—

## WATER DIDN'T TROUBLE THEM.

TWO lumbermen, who had been engaged in various real estate deals together and for themselves individually, met in the office of another friend one day last week. After the salutations had been given one said: "How is real estate?"

"All right. The prospects are as good as ever."

"I'm glad to hear it. Have you been out lately to look at those acres?" asked one of the men who owned the office.

"Yes, I was out the other day. They are still looking up, but we've had so much rain that they are covered with water."

"That's not the trouble with ours, is it Tom?" asked one of the partners.

"No," was the reply. "Ours is covered with mortgages."

## LIFE IN A LUMBER CAMP.

THE lumber camps of the pine regions have within the last few years become an institution peculiar to their time and place. The novelist may yet make a fortune out of incidents directly or indirectly connected with them.

Lumbering, like everything else in this busy, pushing generation, is carried on by the wholesale. The owner of a tract of pine either employs a general manager for the several camps of workmen or lets the cutting of the pine out by contract. If his business is sufficiently large, so that he runs a number of camps, he employs a walking boss, who is the highest authority in the whole business. Each camp has its "foreman," who rules his own domain, subject to the periodical visits and "cussings" of the walking boss.

Each camp is a colony by itself. Everything is provided for the comfortable sustenance of its inhabitants. A camp consists usually of two principal buildings, which are built of logs or boards in some hollow, shaded from the winds, and are long and low. In one of them are the bunks of the men placed along the sides in two or more tiers. In the middle is a long box stove that looks as though it had come out of the ark. At least, one was never seen that appeared to have been new in the present century. Here the men pass the few hours that they are not at work, either sleeping, reading, playing cards or telling stories, and always chewing tobacco or smoking. The Lumber Jack that can't go to sleep with a pipe in his mouth and wake to find it within reach of his hand has not learned the first lesson of a lumberman's life.

The other long, low room is the kitchen, dining-room, pantry and cook's parlor combined. The cook is one of the chief features of the camp. In the woolly days of early logging the board furnished was the poorest kind of "grub." Fresh meat was an unknown quantity, the cooking was on a par. Most camps at present, however, furnish as good or better food than the ordinary run of small country hotels. The cook is one of the highest salaried personages about the camp, and one can find no better place to dine, after a long tramp through the woods, than a modern logging camp. The cook, himself, is only required to cook and fill out his orders for provisions. Under him and directly subject to him is the "Cookee," who builds the fires, brings in the water, washes the dishes and makes himself generally useful.

The daily programme in a lumber camp is somewhat as follows: At three or four o'clock in the morning all hands are called up. A substantial breakfast is served and the day's work begins. Every man has his duty. Some of them upon the hillsides are felling the monarchs of the forest with an ax and saw. After the tree is felled and trimmed it is cut into proper lengths and skidded. The skids are simply platforms made of limbs of trees alongside the logging road. Up to within a few years the logs were conveyed to the landing place by horse-power, each sled carrying from eight thousand to ten thousand feet; but with the increase in lumbering large firms now construct logging railways and haul their logs in long trains by steam.

The men are served four or five meals a day. If their work is near the camp they return thither about eleven A. M., and have dinner. If they are at a distance they are served during the day with lunches, and have a full meal on return to camp at night. The day's work often does not end until eight or nine o'clock in the evening.

Wages and pay-day usually form a bone of contention between employers and employes. Ordinary laborers get from \$15 to \$30 per month of twenty-six days and board. Every man has a camp account of various articles which he buys during the winter, all of which are deducted from his pay. What he buys consists mostly of wearing apparel and tobacco. Liquor is never sold nor openly allowed in camp. The foreman keeps his supplies in the "wanagan," which is simply a large chest, and they are charged to him at the company's office. The men are never paid in cash, but receive time checks, which in camps run in cold climates and during the winter season only are due about the 1st of May. Thus, if a man wishes to quit work in the middle of the winter he receives a time

check, which he must either carry until it is due or get it discounted. The time business is a rich thing for the banks during the winter season. It is, also, a feature which causes much complaint on the part of the employes; but the employers claim that it is the only way they can hold their crews together, since, were it not for this system, the men would combine together and leave them in the lurch on the slightest provocation.

During the season of employment the Lumber Jack stays pretty close at home. He may occasionally take a Saturday night and Sunday off, and when he does he calculates to make the fur and the money both fly. But he is usually tired enough when he comes from camp to go to bed after his supper and omnipresent pipe. Sunday he lies around camp and reads such stray papers or story books as he can find. The local printing office is always a mine of pleasure to him, as its exchanges contain just that miscellaneous kind of reading matter which will serve to pass away an idle hour. The ladies of the Christian Temperance Unions and other societies are, also, doing a noble but often unappreciated work in supplying reading matter to camps. The lumber camps in the pineries often hold the balance of power at town and county elections. The "Lumber Jack" is, however, an indifferent voter and usually casts his ballot as his walking boss or the circumstance of the hour may dictate. His home is here to-day and somewhere else to-morrow. Having no fixed habitation he has no fixed interests. Hence, whatever of a civilizing influence may be made to reach the lumber camps will always be an element in the upbuilding of a better government and a purer moral atmosphere in the towns and cities adjacent to them. When the camps break up in the spring the boys draw what time is coming to them and make for the nearest town. All their worldly effects are contained in a gunny sack or wrapped in a piece of newspaper. The first saloon they strike is usually the "bank" in which their time checks are discounted. Often a winter's wages of \$200 or \$300 is squandered in a night or two. Wine, women and the gaming table take the bulk of it. The Lumber Jack is then open for a new engagement at hard work. And yet, they are not all alike. Many of them are saving and foresighted. From common laborers they rise to the position of foremen, walking bosses and contractors successively. It is but a step from the latter to the ownership of a tract of pine. Many wealthy pine land owners began life amidst the vermin and the foul air of a lumber shanty. Still more than this, the Lumber Jack is not as bad as he is often painted. He may be a spendthrift, it is true, and all his surroundings may be of the vilest, but beneath his woodmen's jacket often beats a true heart. To his friends he is always open and generous to a fault, and the wayworn traveler in the forest of our Northern pine woods can find nowhere a more generous welcome than in a lumberman's camp.

## HORSE-POWER OF SQUARE ENGINES.

THIS table gives the horse-power of the various sizes of engines at 50, 25, 15 and 10 pounds mean effective pressure, with 400 feet piston speed. The revolutions per minute are for "square" engines, where the diameter equals the stroke. The little numbers (606, 303, etc., over the horse-power columns) are multipliers for any other areas of pistons at those pressures, and 400 piston speed per minute.

Diam. In.	Area, Sq. In.	Rev per min	Factor, H.P at 400 feet	Mean Effective Press.			
				50	25	15	10
				.606060	.303030	.181818	.121212
3	7.07	800	.0857	4.24	2.12	1.272	.857
3½	9.62	686	.1166	5.84	2.92	1.752	1.166
4	12.57	600	.1524	7.62	3.81	2.286	1.524
5	19.64	480	.2379	12.90	6.45	3.870	2.379
6	28.27	400	.3427	17.14	8.57	5.142	3.427
7	38.48	343	.4664	23.32	11.66	6.996	4.664
8	50.27	300	.6093	30.47	15.24	9.141	6.093
9	63.62	267	.7713	38.57	19.28	11.571	7.713
10	78.54	240	.9519	47.60	23.80	14.280	9.519
12	113.10	200	1.3709	68.55	34.27	17.965	13.709
14	153.94	172	1.8639	93.30	46.65	27.990	18.659
15	176.72	160	2.1421	107.11	53.80	32.133	21.421
16	201.06	150	2.4371	121.86	60.93	36.558	24.371
18	254.47	133	3.0844	154.22	77.11	46.260	30.844
20	314.16	120	3.8076	190.38	95.19	57.114	38.076
24	452.39	100	5.4956	274.78	137.39	82.434	54.956

## AN AGE OF COMBINES.

THE air is rife with "combine." The whole tendency of trade so far as our more important commercial industries is concerned is in the direction of amalgamation. Within the month three of the largest implement companies in Canada have consolidated. The Massey Company of Toronto and Winnipeg, two concerns that have always had separate management, and the Harris Company of Brantford, the united organization to be known as the Massey-Harris Company (Ltd.) The authorized capital of the Company will be \$5,000,000, with headquarters in Toronto.

The paint manufacturers of the Dominion have about completed an arrangement which will make one firm of A. G. Peuchen & Co. and the Toronto Lead and Color Company, of this city; William Johnston & Co., Ferguson & Alexander, William Ramsay & Co., P. T. Dodds & Co., of Montreal and Henderson & Potts, of Halifax.

The financial returns of the Dominion Brewery of this city, which rather more than a year since was bought up by an English syndicate, have been such that now plans are on foot for the consolidating and buying up of three other breweries and making one gigantic institution of the whole.

The announcement is still fresh in memory of the formation of the Pillsbury-Washburn Flour Mills Co., of Minneapolis, which grouped into one several of the largest mills of the American north-west, and this is followed by word that an English syndicate, under the name of "The Northwestern Consolidated Milling Company" has been formed, and that it has taken over the "Galaxy," and "Columbia," the "Northwestern," the "Zenith," the "Crown Roller" and the "Pettit Mills" plants, six other mills of Minneapolis, with a total daily capacity of 11,000 barrels.

When interviewed by the newspaper press the principals of these big enterprises have been very earnest in combating the slightest suggestion that the strength of these combinations will be used against existing smaller concerns, or that there will be any noticeable increase in prices. There is undoubtedly plausibility and also fact in the claim, that in some cases amalgamation has become a necessity because of the extremes to which competition and cutting of prices has been carried. There is no business in doing business at a loss, which for example, we are told has been the case in the implement business. A greater number of firms have been making self-binders in Ontario, than has existed in the whole of the United States, and with results to force methods of business that have caused alarm to creditors and especially the banks.

It is the case that expenses will be substantially reduced as an outcome of each one of these amalgamations, and the inference is that this circumstance will at least work against any increase in prices, and possibly may lead to a reduction.

So far as a business combine of any kind tends to more healthful methods of doing business it is a blessing. The country and individuals are all losers by the ruinous course often adopted by business men to keep themselves afloat, the growth of an over keen anxiety on the part of one to get ahead of the other. Failure is inevitable in every such case, and whilst the consumer is temporarily the gainer by being enabled to buy cheaper goods, he in the end suffers in the general pinching that follows commercial disaster. As individuals we can prosper only in the measure in which the whole country is prosperous.

Unfortunately history tells a dark story of combinations and monopolies. Benefits such as we have named accrue to the public, but too often these are more than outweighed by the selfishness and grinding greed which seem to be born of monopoly and which a combine of any kind suggests and breeds. Everyone will hope that these latest additions to the catalogue will show a record different from that of many of the combinations that have preceded them.—*Canadian Miller.*

They were talking about trees, "My favorite," she said, "Is the oak. It is so noble, so magnificent in its strength. But what is your favorite?" "Yew," he replied.



## USEFUL INFORMATION

A thorough application of red lead to iron and steel surfaces exposed to the weather, is said to be the best means of preventing rust.

An artistic effect has been produced by India rubber panels or veneers, which are very beautiful and admit of easy cleaning with soap and water.

There is nothing which will squelch an oil fed fire in its incipency more quickly and effectually than sand—and there are no afterclaps in the way of water damage, either.

Locomotive practice shows that steel stay bolts snap sooner than bolts made from good brands of iron. The fault, which seems to be incurable, lies in crystalline structure of steel.

By the application of chloride of antiomy a beautiful violet color is imparted to brass work. The brass should first be made perfectly clean and heated until water will steam off it without hissing.

An engineer asks the following pertinent question: "Who should be the most competent to decide as to the condition of the boiler, the man who owns the boiler or the man who cleans and cares for it?"

A method of stopping cracks in metal is to moisten the cracked surface with petroleum, then wipe it and immediately rub with chalk. The petroleum exudes and shows the exact course of the crack. At the end of the crack bore a hole, and the crack cannot go further.

Don't use resin on belts. It shortens their life in elasticity and durability. Instead, use castor oil; but do not soak the belt in it. Let it run from a small spouted oil can on the belt while it is in motion moving the stream of oil at every round turn of the belt until all has been bathed.

A well-known locomotive engineer declares that if he could invent a red paint that would withstand the action of the fire, he would have no difficulty—by painting the inside of fire boxes with it—in getting certificates of a saving of twenty-five per cent. in fuel.

A writer replying to the query, "What will prevent belts slipping?" says: Let me answer for all—a little common sense. If a man is drawing a hundred bushels of wheat to your mill and the wagon gets stuck, he must either take off part of the load or hitch on more horses. It is exactly the same with a slipping belt. You must either lighten the load or else put on a heavier belt. In 99 cases out of 100 the trouble will be entirely obviated by putting on a double belt. Rest assured that any kind of a daub placed on a belt will be a detriment instead of a help. The belt will run better for a few minutes and then this stuff will collect on pulleys and in places on the belt, making it much worse than ever. The best dressing that I have ever seen for leather belting is a little castor oil.

It does not appear to be generally known that almost any kind of fine dust floating in the air is highly explosive, when the proportion of dust to air reaches a certain percentage. This should be remembered by those who are employed in establishments where quantities of dust, either from sugar, flour, wood, or any other article, is apt to accumulate. Usually the fatal step is made by carrying a lighted lamp into some dusty department. There need be no danger if the objectionable dust is allowed to escape, and there is very little risk if those concerned take pains to keep any flame from the dust-burdened air, though it is advisable to always keep such buildings well ventilated. Experience is beginning to teach that there are many other explosives besides oil and gases. It has been recently reported that an ice factory exploded, so the only safe plan is to exercise care in all departments of manufacture.

All tough timber, when the logs are being sawed into lumber of any kind, whether scantling, boards, or planks, will spring badly when a log is sawed in the usual manner, by commencing on one side and working toward the other. In order to avoid this, it is only necessary to saw off a slab or plank alternately from each side, finishing in the middle of the log. We will suppose, for example, that a log of tough timber is to be sawed into scantling of a uniform size. Let the sawing be done by working from one side of the log to the other, and the end of the scantling will be of the desired size, while at the middle some of them will measure one inch broader than at the ends. After the log has been spotted, saw off a slab from one side; then move the log over and cut a similar slab from the opposite side. Let calculations be made before the second is cut off, so there will be just so many cuts—no more, no less—allowing for the kerf of every cut—about one-fourth inch for kerf. When sawed in this way, the cuts will be of uniform thickness.

### CANADIAN LUMBERMEN.

MR. KENNEDY F. BURNS, M. P.

LUMBERMEN come prominently to the front in whatever part of the Dominion they may reside. One of the most extensive operators in any of our Provinces, and holding a first position among the lumbermen who can write "M.P." after their names, is Mr. Kennedy F. Burns, of Bathurst, N.B., and member for Gloucester.

Mr. Burns, was born at Thomastown, in county of Tipperary, Ireland, on the eighth day of January, 1842, and came to New Brunswick when a boy, was educated in Halifax, N.S., and St. John, and from the latter place removed to Chatham, N.B. in 1857, where he was engaged in business with the late firm of Burk & Noonan, and finally settled in Bathurst in 1861, where he began a successful business career. In 1878 he formed a business partnership with Hon. Samuel Adams (now of New York) and his brother Mr. P. J. Burns, the new firm going more extensively into the lumber business, building one of the finest saw mills in the province at the mouth of the Nepisiguit river, opposite the town of Bathurst, and carrying on a general lumber and mercantile business at Bathurst, Caraquet and Petite Rocher.

On the retirement of Mr. Adams, the new firm of K. F. Burns & Co. was formed and carried on the same



MR. KENNEDY F. BURNS, M. P.

business until May, 1890, when it became merged in the large and important concern—the St. Lawrence Lumber Company, limited, with mills at Bersimis, Que., Bathurst and Caraquet, N.B., and offices in London and Liverpool, Eng. Of this prosperous company, Mr. Burns is the managing director and largest stockholder.

Mr. Burns first entered political life in 1874, when he was elected to represent Gloucester in the House of Assembly, and has ever since been a prominent figure in the political affairs of his county. In 1882 he entered the larger sphere of Dominion politics, defeating Hon. T. W. Anglin in the general election held in that year, was re-elected at the general election of 1887, and has again been returned in the recent election.

Mr. Burns has always been a staunch Conservative, and has been untiring in his efforts to benefit his constituents. Through his strenuous efforts he succeeded in pushing to completion the Caraquet railway, of which he is now president and general manager, a much needed line running from Bathurst to Shippegan and connecting with the Intercolonial system at Gloucester junction.

Straight and square dealing has ever been a motto of Mr. Burns, and to this may be attributed much of his success in life. His is a case where it can be written with all truth, "his word is as good as his bond." It is a compliment to any man to be able to

say that "his best friends know him best." This is Mr. Burns' record. He is kind and generous in disposition and among his workmen and employees everywhere he is very popular. He delights to mingle in the sports and pastimes of the younger men and becoming as it were, "one of the boys." By some of his public opponents he has been dubbed the "boy" a title of which he is very proud.

In his make-up Mr. Burns commands the respect of all who measure the elements that go to the making of a good life. Hopeful and energetic yet unassuming in every transaction, unassuming in private life, yet recognized by all as a leader among his fellows, affable and courteous in manner, yet decisive in all his actions—he possesses in no common degree the art of winning and retaining the high esteem and respect of his very numerous friends and acquaintances. Having started out with few advantages—intelligent, industrious and self-educated, methodical in all things—he has by his own inherent ability climbed his way to the top of the ladder. He is a lumber shipper, a mill owner, a farmer, a trader, a politician and a horseman. His friends say he is a lawyer as well, but these apparently are but the ephemeral joys of his busy existence.

In private life and among his more intimate friends, Mr. Burns is noted for his geniality and good nature. Nobody enjoys a joke better than he, even when directed against himself, and his keen Irish wit sometimes turns the tables on the joker most effectively.

### A GREAT SIBERIAN PINE FOREST.

A RUSSIAN traveler gives an interesting account of the Siberian forest called the Taiga. He says it is so vast that not even the peasants who were born in it, and have lived there all their lives, know how far it extends. The peasants declare that in the winter strangers from the North come on reindeer to sell bread. What people they are, or whence they come, the peasants can not say. They only know that they are not the same race as themselves and do not speak the same language. This mysterious people, it would appear, have never been seen by any one but the inhabitants of the forest, who are themselves almost uncivilized, living upon what they shoot. The trees, which are pine, are wonderfully thick and high, and a dead stillness prevails in summer, an attribute common to all Russian forests. This silence has a peculiar effect on the traveler after he has been journeying for many hours, especially if he is alone. At the end of the first day the traveler says he ascended a hillock, and as far as the eye could reach stretched an endless sea of trees. At the end of the second day only the same scene was to be observed, although he knew that Irkutsk and open land lay beyond.

### HIS FATHER GOT THE WRONG END.

THERE was a big buzz-saw boxed up and ready to go on shipboard at one of the South street wharves the other day, when a colored man was noticed walking around it and eyeing it with the greatest interest.

"It isn't running," finally remarked a shipping clerk.

"I kin see dat much," was the ready reply.

"Then what are you afraid of?"

"I isn't 'fraid of nuffin'. Ise simply sorter anxious."

"Ever see one of those things before?"

"Can't say as I hev."

"Then what are you anxious about?" persisted the man.

"See yere, boss," said the other as he retreated a step or two. "I lost my fadder when I was only a baby."

"Well?"

"I lost him kase he walked up the wrong end of a b'ar, an' I doan' reckon to git cotched in the same way. When I see anything wid teeth to it I either shy off or dodge behind."

IT has been calculated that the electromotive force of a bolt of lightning is about 3,500,000 volts, the current about 14,000,000 amperes, and the time about one twenty-thousandth part of a second. In such a volt there is an energy of 2,450,000,000, volts, or 3,284,182, horse power.



PUBLISHED MONTHLY BY  
ARTHUR G. MORTIMER.

OFFICE:  
75 CANADA LIFE ASSURANCE BUILDING,  
TORONTO, ONTARIO.

TERMS OF SUBSCRIPTION:

One Copy one Year, in Advance, - - - - - \$1.00  
One Copy six months, in Advance, - - - - - 50

Advertising Rates Furnished on Application.

DOMINION LEGISLATION.

THE members of the Dominion Parliament have been "hard at it," to use a vulgarism, for a whole month. It can hardly be claimed that they have yet given the country anything startling, much less useful, in the shape of legislation. The Speech from the Throne foreshadowed nothing remarkable in this direction, and whatever may be forthcoming will have to be the outgrowth of the work of the session.

As is the case usually in the first session after an election and particularly when the contest was as bitter as that of March 5th, and the majority for the "Ins" somewhat slender, the major portion of the time of the House is taken up with motions and movements having a tendency to compromise and affect the position of the majority—aiming at its abolition. The Tarte-McGreevy scandal, concerning as it does the character of a minister of the crown, Hon. Hector Langevin, is in this instance proving just the nicest morsel that the opposition could have hoped to taste. The case is still *sub judice*, and we have no desire to prejudge, but there is no question, that surrounded by various peculiar circumstances and relations, it is proving an annoying and worrisome matter to the Government—and especially to the First Minister.

'Tis pity that the trend of politics in this age is so completely partizan that the important function of Government to create and enact wise measures for the betterment of the condition of the people and the advancement of the country's commerce must be given a subordinate place, whilst the unsavory occupation of washing the legislators' dirty linen is proceeded with.

THE LUMBERMAN refers to the matter with no party bias whatever; this is not its vocation; simply to regret that these things exist. Important questions bearing an intimate relation to the financial welfare of the Dominion are pressing for a solution, and as a commercial journal, it is these we should hope to see engaging the attention of the Commons.

When the debate on the Budget takes place, we may expect that some of these matters will be discussed, but it is measurably certain that so high will party feeling run, that no equitable and common ground will be reached.

In the opinion of those who are watching closely the throbbing of the political pulse we are hardly likely to have many, if indeed any, tariff changes of importance this session. Various deputations of manufacturers and commercial men have interviewed the Government, and others are to follow; their wishes will be courteously considered by the Cabinet, but some other day, not to-day, they may receive practical demonstration.

Only one question of direct interest to lumbermen might find a place on the papers of the House, and that is the possible re-imposition of the duty on logs. We have no reason to suppose that it will obtain precedence of other questions, concerning other interests, that to those concerned, are of equal importance with this. A quiet agitation is going on in different portions of the press for a change in the duty. And it is noticeable that the severest criticisms on the action of the government in abolishing the duty is coming from the government organs. The contention is that the step is one directly in opposition to the spirit of the

National Policy; and the *Shareholder* of Montreal, and the *Canadian Manufacturer* of this city arraign the government in vigorous terms for what they have done; to quote the classical language of the latter journal, the organ of the Red Parlor, "the Canadian government ought to put a stop to the depletion of Canadian forests p. d. q." THE LUMBERMAN is desirous to get at—not what political view any particular individual may hold on the question, but what is best, taking the whole problem in a broad and liberal light, for the general interests of the entire country. As a means to this end we publish again this month the opinions of lumbermen engaged in business in different sections of the Dominion, and shall be pleased to hear from others.

RAILWAY BONUSES.

WITH the story of the iron horse is written the progress and development of every country, and individual sections of country. What Toronto owes to her splendid railway connections will perhaps never be fully realized by the great body of her citizens. What would come of our immense shipments of lumber, grain and general merchandise, were it not for the trundeling freight train travelling the country from end to end?

No other explanation can be given of the liberality—sometimes prodigal in extent—of municipalities and governments in bonusing railways in all parts of this Dominion. We have no carping criticism to heap upon the railway corporations of the country. We owe them much, even though we have sometimes paid dearly for it.

But it is not all gold that glitters and there is another side to the shield. A large and influential deputation of municipal magnates, representing 22 counties and five cities in Ontario, waited on Sir John Macdonald and the Minister of Finance, Mr. Foster, on 21st ult., to ask for a recoupment from the government for bonuses granted in years gone by. It has been part of the policy of the government to assist in the construction of railways in Canada by granting subsidies of \$3,200 per mile. The claim of the delegation here referred to, is that they as municipalities had taxed themselves to construct railways, without any government aid and at a time when railways were more a matter of necessity than they are to-day. Why should they not be placed in the same position as those municipalities which are now being aided, and as they would likely have been aided if the railways in their respective counties were under construction at the present time, instead of having been built many years ago. The general reply of the First Minister to this plea is, that whilst it is true that municipalities in Ontario have paid out of their own pockets to this purpose, at same time Provincial Governments, for example Nova Scotia and New Brunswick, where the municipal system is not so perfect as in Ontario, have from the provincial funds built railways and as a consequence taxed the people for this thing—"we cannot consider the claims of any one province without considering all." There is no difficulty in reading between the lines, in the speeches of both Sir John and Mr. Foster, and coming to the conclusion that the visit of the deputation to Ottawa, whilst doubtless exceedingly enjoyable, will not be productive of any practical results.

The spokesmen of the deputation were, Mayor Walsh of Orangeville; Mr. S. J. Parker, treasurer of the County of Grey; Mayor Porter, of Belleville; Mayor Taylor, of London; and Jonathan Sissons, warden of the County of Simcoe, and it is from the speeches of these gentlemen, that some interesting inside figures are obtained showing the amount given to railways by various municipalities, the conditions under which these bonuses were granted, and how nicely the railway corporations adhered to their agreements, after they had made sure of the collection of their money.

The city of Belleville had bonused the Midland railway in a large amount. By the by-laws raising the bonuses, certain rights were guaranteed the municipalities. Some of these were embodied in the act of incorporation of the Grand Junction railway, but in the amalgamation which afterwards took place with the Midland, these rights were entirely wiped out. The

city of London had granted \$100,000 to the London, Huron and Bruce, and the county of Middlesex had contributed largely to its aid, but "the promises solemnly made had not been carried out to the satisfaction of the people." Simcoe county paid in the neighborhood of nearly \$1,000,000 for railways. Part had gone with the purpose of erecting a competing line with the old Northern, but it was not long before the North-western found it to their advantage to unite with the Northern and the competition for which the people had paid no longer existed.

These few cases are typical of scores of others that could be cited, and that are confined to no one section of country, or any one railway corporation. Many of the municipalities which voted large sums of money to certain railways are to-day worse off locally than if no railway whatever had been built, because of their trade being diverted afterwards in other directions, where for the time it was found more desirable to grant railway facilities, practically by the same promoters, who had held out to the first municipality the Eldorado that was before them if they would only vote right on the bonus.

This may be all explained away as justifiable commercial methods—on the principle of "get there" anyhow—and corporations being soul-less such a code of morals may be good enough for them, but in private and ordinary business transactions rather more honor would be exacted.

Still the bonusing business continues and it would not be surprising to learn that the municipalities that have suffered and lost most in this way, are ready to go over the same ground again, go another \$10,000, if only the lyre of railway orator is tuned to play in sufficiently sweet and silver-tongued tones.

IN FAVOR OF CANADA.

AMERICAN lumber dealers, who are interested in finding a market for Michigan and Wisconsin rather than Canadian lumber are incensed at the action of certain American railways in entering into arrangements with the Canadian Pacific discriminating against American shippers of lumber to the advantage of Canada. The case is put thus by the *North Western Lumberman*:

"The rate on lumber from Chicago to New York is 25 cents a hundred; to Boston, 30 cents. The rate from Buffalo and Tonawanda to New York is 13 cents a hundred, and to Boston 15 cents. Last winter the New York Central made a traffic arrangement with the Canadian Pacific, by which a pro rata rate was established, so that when lumber is shipped to the eastern points named, the cost, east of Niagara river to New York, is but 9½ cents a hundred, or 3½ cents a hundred below the Buffalo and Tonawanda rate to New York. Thus, though the duty on Canadian lumber is \$1 a thousand, it is nearly offset by the discrimination in rates against American dealers shipping from Tonawanda, Buffalo or any other point west of those markets, effected by the combination between the great Canadian railway and the American roads named. This is in keeping with the general complaint that has been made by American shippers, that the Canadian Pacific has for some time made rates on traffic entering United States territory that resulted in diverting shipments from American roads, as well as operating adversely to dealers and shippers on this side the international boundary. It has been charged by the railroad companies, whose lines are exclusively in the states, that the Canadian Pacific makes rates on traffic between Pacific coast points and the east that cannot possibly be met by the complaining roads, owing to the restrictions of the national commerce law. It has also been charged that much traffic has been diverted to the Grand Trunk road by the advantage that it possesses in the respect named over the American lines."

The result of this discrimination we are told is to operate specially against the sale of lumber manufactured in Michigan or Wisconsin, and distributed by Tonawanda and Buffalo dealers. Boston and New York dealers state that with the \$1.00 duty added they can lay down Canadian lumber in their yards cheaper than from points east of Niagara Falls.

All this is making our good friends around Tonawanda feel very sore. We can understand that it is very naughty for railroads like the New York Central for example to enter into these combines with sister roads, and especially with Canadian roads. But we cannot do anything on this side of the border to remove the trouble. We can hardly regret that our own roads are considerate enough of our own interests to deal with us generously in the matter. We are not to be expected to shed tears over the fact that their influence with American roads is of that calibre to imbue them with a like kindly regard for us. After all, is not somebody in the American republic a gainer by this railroad combine? Michigan and Wisconsin lumber may be at a discount in the eyes of New York and Boston, but then they get good Canadian stuffs, and evidently at a better price, or they would not buy it. It's not all loss to our American friends.

## EDITORIAL NOTES

HAVE you made the acquaintance of Eli? He talks to you again in this month's LUMBERMAN.

THE forestry commissioners at New York are fighting against the building of any railway through the Adirondack forest reserves. They have applied for an injunction to stop the building of the Adirondack and St. Lawrence railroad.

THE *British Columbia Commercial Journal* is the name of a new weekly newspaper published at Victoria, B. C., and devoted to the mercantile interests of the Pacific coast. It is bright and newsy, and editorially faithfully and ably espouses the interests of this important commercial corner of the Dominion.

AT the meeting of the Presbyterian Synod in Montreal on the 15th ult, Rev. Dr. Armstrong told of his mission work among the shantymen of the Ottawa Valley and neighboring vicinities. During the season 250 camps had been visited, a large supply of valuable literature had been circulated, and the missionaries and their papers we are told, were heartily welcomed by the shantymen and miners. Another year the Presbytery hopes to increase the visits and the supply of reading matter.

THE *Merchants Magazine and Financial Review* published in Montreal by Mr. Frank Weir, which dates its inception from April, will fill an important place in Canadian commercial journalism. We have several creditable weeklies devoted to trade and commerce, but it is only in a monthly that we can expect that careful and accurate summing up of events, where the hurry of weekly journalism, is not felt, that is so necessary to a correct casting up of results. Judging by the number before us, this new claimant in the mercantile field will ably fill the bill.

WE are pleased to publish in "Our Letter Box" a number of communications from readers of the LUMBERMAN. We are not going to say that we agree with the views expressed by all our correspondents. It is not necessary that we should. Lumbermen, we are sure, are liberal minded enough at any time to agree to disagree. We want to hear from our friends at all times; whether to indulge in a shaft of criticism, impart a piece of practical information, or record some items of news in their district, their letters will always be welcome.

IT is stated that Assistant Secretary Spaulding, of the United States treasury department, in reply to a Chicago law firm asking in behalf of certain of their clients who own timber land and stumpage in Canada, and from which they produce under their own supervision railroad ties, fence posts, etc., at what value they should be invoiced, their dutiable value in this country, etc., has informed them that the invoice should specify the actual market value or wholesale price of the merchandise at the time of exportation to the United States in the principal markets of the country of importation.

AN American contemporary raps over the knuckles those newspapers that have the "beastly" habit, as the editor puts it, of speaking of logs as lumber. The charge is laid particularly at the door of the press of New Brunswick. These papers, we are told, will say "that some operator put in so many feet of lumber on such a river the past season; or that lumber is coming out of such or such a stream in good shape." There is of course a marked difference between logs and lumber, and the "boys" of the maritime press will have to call things by their right names. Of course our American newspaper men never make such blunders. Oh no!

Mr. J. Fletcher, of the Experimental Farm, Ottawa, has been lecturing on "The most suitable ornamental shrubbery for this climate." As lumbermen we're sometimes apt to look too much on the trees of the forest from a hard practical standpoint, as something of wonderful utility, forgetting that they are alike, "a thing of beauty," and without throwing any uncalled for sentiment into the question, "a joy forever." The beauty of our leading Canadian cities is due to the commendable custom, which might be more widely cultivated of planting shade trees along our principal streets. The lecturer recommended for shrubbery purposes the growing of the Russian, English white, the ornamental and rosemary leaved willow, the weeping birch and the magnificent American elm of which there were few trees to equal; Canadian white cedar and the Siberian pine tree, of which there were 15 varieties.

THE forestry display of the Chicago World's Columbian Exposition will be one of the important features of the World's Fair. Every effort is being put forth by Mr. W. I. Buchanan, Chief of the Department of Agriculture, who has charge of the forestry department, to enlist the co-operation of the various timber and lumber interests, and an effort will be made to have a special building erected to be devoted to the timber industries. A good deal of attention will be devoted to forest botany, the distribution of forests, of genera and of species, as well as the anatomy and structure of woods, and the diseases of forest trees and timber. Forest management, maps, illustrations, and instruments for measuring standing timber; growths of different ages and soils; graphic and other illustrations showing rate of growth; influence of various managements on tree growth; statistics of the lumber trade and of forestry; the harvesting of forest products; the turpentine and charcoal industries will all receive proper attention.

THE fire losses in the United States and Canada in March this year footed \$12,540,750, against \$8,466,300 in 1890, and \$10,912,000 in 1889. The woodworking and allied industries contributed about \$750,000 to the total for March. These are large figures showing the devastating effects of fire, but they will be immensely increased, so far as the lumber interests are concerned, for the month of May. In another column we publish a list of fires in the lumber sections during May. They have been largely in the States, though we have not escaped in Canada. The damage in New Jersey foots up at least \$1,000,000, at one point alone, 25,000 forest acres were burned. The Schroll & Ahearn's mill company of Wiona, Minn., lose \$100,000 by the burning of their mill, blocks of lumber and warehouses. Michigan, the scene in the past of intense suffering and financial loss, counts in again to the amount of several million dollars of damage. Long Island, Pennsylvania, Wisconsin and other States have been included in the sweep of the fire monster. It has been in the vicinity of Gravenhurst that our greatest losses have been made. From all parts comes the prayer for rain. It's needed to stay the tread of the travelling flames, and the country requires it too, the better to assure the certainty of the present hopeful harvest.

NO section of the continent is working up a boom on lumber more vigorously than the residents of the Southern States. A timber famine may be imminent in the near future in some parts of the American continent, but not "Away down South in Dixie," or elsewhere among the cotton fields. Yellow pine is being boosted for all our Southern friends know how, and from some of the more enthusiastic comes the prediction that it is making serious inroads into the sale of the white pine of Michigan and other northern states. But our contemporary the *Southern Lumberman* does not want Europeans or other people in the Northern States or Canada to run away with the idea that southern timber is confined even to "cypress, magnolia, and long-leaf yellow pine." As a matter of fact, we are told the varieties of woods in the Southern States are infinite. They embrace such woods as oak, poplar, hickory, ash, beech, cucumber, walnut, cherry, chestnut, buckeye, lynn, elm, maple, birch, gum, sycamore, lo-

cust, pine, balsam, sassafras, mulberry, dogwood, sourwood, peawood, satinwood, hackberry, persimmon, holly and many others. Hurrah for the Sunny South! We cold-blooded folks of more northern climes will have to look after our forest laurels.

THE destruction of forests has certainly compassed failure of a good many water powers. This paper is not an alarmist, but the question of woods and rain is one that must sooner or later receive intelligent attention from powers that be.

This statement we find in a contemporary devoted to milling interests. It is another argument for forest preservation. The scarcity of timber itself, which we're apt to look upon this time as far remote, perhaps mistakenly so, will prove a troublesome matter for this country. But in the meantime other interests are suffering seriously because of the almost entire cutting out of anything in the way of a forest in all the older settled sections of the country. Here we have a journal which makes a study of questions affecting the milling trades, pointing out the impairment that has been caused to many water powers for the want of the growing tree. In last month's LUMBERMAN we referred to the testimony of 200 farmers who told of the much better crops that were raised when timber was standing than since more has been cleared. We're neither alarmists nor fadists, but the question is one of sufficient import to call for consideration from those engaged actively in the lumber trades.

MESSRS. RIOPELLE & SMITH of Quebec says *Le Canada* have sold for \$82,500 a timber limit in the township of Ballantyne, to the Moore Lumber company, of Detroit. This limit was bought from the Ontario Government at an auction some years ago for \$49,000. Mr. Riopelle has been very lucky in his timber limit speculations. A few years ago he entered into partnership with Honore Robillard M. P. and, the latter obtained from the federal government, for the firm, a piece of Indian reserve timber limits on Whitefish lake, for \$312. Mr. Robillard shortly afterwards sold his interest in the limit for \$15,500 cash, but Mr. Riopelle retained his share for some time selling it finally for \$27,500. In connection with Mr. Robillard's purchase from the Dominion Government Mr. Barron M. P. has moved in the Commons, now in session for a return showing what quantity of timber or other wood has been returned to the government of Canada, as having been cut up to the present time from off Indian reserve No. 6 of the Robinson treaty by the licensees or vendors of the timber thereon since the sale to Honore Robillard, M. P., what amount of revenue or dues has been paid to the government since the sale thereof, from the vendors or licensees, on account of timber or wood cut thereon. Mr. Barron is also moving for a return showing the quantities and kinds of timber and sawlogs cut annually on the lately disputed territory in the province of Ontario, under the authority of timber licenses issued by the Dominion government.

CHIEF JUSTICE SIR THOMAS GALT has recently given a decision which practically knocks the bottom out of the Ontario Act respecting assignments and preferences by insolvent persons. He decided that clause 9 of that Act, which provides that assignments shall take precedence of judgments and executions, was ultra vires. As the British North America Act says that the Dominion Government only shall have the power to deal with bankruptcy and insolvency, the Provincial Governments may not make laws taking away the priority of an execution creditor, as such would be legislation relating to bankruptcy and insolvency. In the case in which his Lordship gave decision one Neville, an Ottawa merchant was in business difficulties. The Union Bank got an execution against him and seized his stock. Shortly afterwards he made an assignment to John Moran. Under the authority of this assignment Moran demanded possession of the stock. Under the Ontario Act he was entitled to it, but Mr. Meredith, who represented the Union Bank, took the case into court. In Chambers the decision was against him. He then took it before the Chief Justice, who decided as above. Mr. H. T. Beck, who represented the trustee Moran, as well as the attorney-General of Ontario, will carry the case to the Court of appeal. In the meantime Sir Thomas Galt's decision stands. If a creditor now gets his execution in he retains the right to realize on the goods seized entirely for his own benefit. It will be a race between creditors as to which shall get in the first execution.





A FRIEND has written me from Madawaska, N.B. He expresses the hope that "Eli's pen will prove mightier than the sword to cut the thread of begottd ignorance and imbecile legislation, such as removing the export duty on our logs and allow Americans to retain their duty on spruce and raise it on cedar, giving them a premium over us to slaughter our forests." I am after all 'em fellows who would give away this country of ours even to a beloved Yank; and in my opinion it was a serious blunder of the government to have included spruce with logs when removing the export duty. This legislation is especially rough on the lumbering interests of New Brunswick, where spruce forms so large part of their stock in trade in lumber. Of course the Yank had an eye to business here, spruce being the chief growth of the Maine forests, the State that can claim the Plumed Knight of the Harrison cabinet, and in the arrangement of tariff matters, this much was made solid for Maine. On the general question of the removal of the export duty on logs, opinions of lumbermen are undoubtedly a good deal divided.

"The lumber trade would certainly be injuriously affected in Canada," said Mr. Sinclair of Paisley, "should any course of legislation necessitate an increase in the import duty on lumber going into the United States. Since the reduction of the duty from \$2 to \$1 we have been enabled to ship in much larger quantities to the States. Our cutting is chiefly hardwood, maple to a good extent. We have also some cedar in this locality. The woods however in this section are getting cleared and in about 10 years we'll not have very much more of the present forests to cut."

Duty or no duty continues to be a leading question in lumbering circles. Wherever I meet lumbermen the matter comes to the front in some shape. "We have been able," said a large operator, "to get lumber into the United States that could never have been shipped there with the extra dollar duty in existence. We have shipped over, 1,000,000 ft. culls across the line, that hitherto remained here depending entirely on local trade for a market. And this has been the case with other lumber, besides culls, that has gone from Canada. I am speaking now of lumber, manufactured at our Canadian mills. No doubt the abolition of the log duty has had some local effect among saw mill men, but as between the injury it has caused the few and the general benefit to the entire lumber trade there is a wide gulf."

Nothing better than history to help in the intelligent discussion of a question. One need not necessarily follow in the line of history always; but it is an experience and as such is an actual guide post of what is best and wisest to follow—it may be; or to shun; or perhaps modify. I have come across a bit of Scottish history touching the matter of forestry, that may point a moral or adorn a tale in this newer land. The Scotch are proverbially a canny people and their recognition of the value of forests and the danger arising from denuding the land of them was very early. In 1535 the Scottish parliament passed a law inflicting the death penalty upon any one convicted of stealing timber for the third time from the public domain. The area in timber in Scotland in 1812 was 913,698 acres, in 1872, 734,490 acres and in 1881, 829,476 acres. And the same lively and intelligent interest in forestry is taken by the Scottish people to-day. I don't know that they do any hanging now-a-days, but they are adopting the more intelligent methods of modern times and propose establishing a school of forestry, so as to educate the people up to a higher understanding of the value of this God-given wealth.

"The curse of the lumber trade in this country," said Mr. J. Gray, of Geo. Hastings & Co., city, "is the credit system. We sell a lot of stuff, nearly all on time, and then every little while some fellow goes under and taking the season throughout losses enough are made to take off a good slice of the year's profits." How about duty on lumber, inquired "Eli?" "I am on the road nearly all the time," said Mr. Gray. "Along the North Shore the mills are feeling the effect of the large shipment of logs to the States, and where they do not close down, they are running on short time. Whole communities are affected of course where this is the case, men are thrown out of employment, the storekeepers lose their customers and villages will be depleted. All this is offset by certain general benefits. Timber limits are made more valuable; and coarser lumber, even culls, that with the heavier duty could not be shipped to the States are going over there in considerable quantities. The lumber trade is in this way benefitted. Where the Americans are towing logs over to be cut in their own mills, they are leaving behind a lot of rough stuff, tops of trees and that like, which are not going to benefit our limits any."

A reader of this page takes me to his bosom in this fashion: "Eli, you have a venerable appearance, evidently a man of great wisdom and good nature. I like your smile and your nose. Your mature years are a guarantee that whatever appears in your columns will be worth the most serious consideration of mankind. The writer is most pleased to learn that the CANADA LUMBERMAN has found its way to far off India. Permit me to say a word or two about forest administration in India. The forest officials of that part of the British Empire, by their zeal and scientific knowledge, have placed the administration of the forests beyond that of almost every other country. In 1886 a revenue of about £2,000,000 stg. was obtained. Formerly there was not only an entire absence of revenue but a capital each year becoming less. The rapacious timber dealer, who cut but for self aggrandisement, was restrained, and a course between reckless waste and legitimate demand, was followed resulting in the revenue mentioned above. If you could induce some Indian forest official through your subscriber, to send an article or two on the subject of forestry, from which we Canucks could learn how to manage our fast disappearing forests, you would be doing a very wise act, and for which your descendants, near and remote, would rise and call you blessed. In the language of Milton; "Long may you wave. Adieu my venerable friend."

In my ramifications among business men I get wormed into discussions on many different topics. The oft' talked of subject of advertising came up the other day in a business office in this city. Did it pay to advertise was the not very fresh query? One occupant of the office doubted it, another said it was a wasteful waste of money, the owner of the establishment himself was spending a considerable sum in this direction, and speaking from his own experience he knew that advertising paid. I was a listener rather than a talker; was indeed "a chiel among them taking notes," and it was interesting to diagnose the case. "A" was sceptical—truth his calling did not throw him in the way of advertising, he had not studied the question closely and yet as only a casual observer he could not believe that so many shrewd business men would spend the amount that was indicated by their space in leading journals, and do this continuously if no results were forthcoming; so that for this reason, while mentally he had misgivings, he was not going to dogmatise. "B" was a business man of the old school, fortune and special circumstances had favored him, so that without much effort he had made money, and "he didn't have to throw any away in advertising either," and taking his own experience to be typical of the general experience, instead, it was exceptional, he denounced the whole business as a humbug. We've all met these kind of people and the logic of a John Stuart Mill would be wasted on them. Who was number three? Well he was an advertiser. He had faith in printer's ink and he had shown it by his works. He did not, it is true, make a

thousand dollar contract thoughtlessly. The medium offering advertising was studied. Did it suit his particular needs? As a manufacturer he believed in trade journals, as reaching specially the people with whom he could expect to do business. He knew that not only was a trade journal carefully read by its subscribers, but in nine-cases out of ten it was kept on file for future reference—yes for the advertisements, as well as the general reading. He paid attention to his advertising. His argument was that if it paid to spend a given sum per year in this way, it paid to have it looked after and well done, and I happen to know that there are few "ads" in any of our newspapers more striking than those that bear this firm's name. He knows how to advertise and it pays. I got some pointers on advertising in this short half hour with men of various minds that will be valuable to me.

A few days ago I called on Mr. James Tennant, the well-known lumber merchant of Victoria street, and whilst there had an interesting chat with Mr. Christie, one of the oldest and most respected members of the trade in Canada.

Speaking of general business, Mr. Tennant had the same story to tell, that is found recorded elsewhere in this page from the lips of Mr. Gray. "Business in Canada," said he, "is awkwardly handicapped by the extent of the credit system. We sell on three months' time, and too often are obliged to renew the larger part for another three months. In the States terms are at the outside 60 days and more frequently 30 days or net cash. It is a steady cash outlay by the manufacturer from the time the men go into the woods until the finished lumber is ready for the dealer, and just as much as the load of wheat the farmer draws to market, and sells only for cash, should lumber be net cash."

"General business," said Mr. Tennant, "is quiet. Dealers all through the country complain of a scarcity of money and as a consequence few purchasers. Trade in the city is akin to the conditions in the country notwithstanding the figures paraded in the daily press assuming to show a large increase in building permits over last year. Permits to-day are issued for almost every stick of building that goes on; in 1890 this was not so."

"Besides," joined Mr. Christie, "a large part of this year's building is such as you see across the road—pointing from the office window to the massive stone structure of the Loan Association being erected on corner Victoria and Adelaide streets—in which there is very little wood used."

"Most certainly the reduction of the duty on lumber to one dollar a thousand," quoth Mr. Tennant, "has increased shipments to the States."

"And there has been no general closing down of saw mills along the North Shore," added Mr. Christie, "such as was predicted. I have been pretty nearly over the whole of that ground this season, and only know of two mills that have been closed, and there were exceptional reasons for this. The mills at Spanish river, Bying Inlet, Victoria Harbor, Parry Sound, Collingwood, Pt. Severn, Cook Bros.' mill, Bryant's mill and a string of others I could name are all running and doing good business. No such quantity of logs as some have named is being shipped to the States. Pity is that the duty was not removed entirely. There should be complete free trade in lumber."

"The extra shipments of lumber to the States," resumed Mr. Tennant, "are also having some effect in stiffening prices in Canada. I have no idea that the government will make any move to reimpose the log duty. The Ottawa lumbermen, among whom are some of the strongest friends of the government, would never consent to any step that would lead to an increase in the duty on lumber, and the reimposition of the duty on logs would of course work this way."

"Moreover," said Mr. Christie, "as a matter of policy it is the worst thing the government could do. Commercial interests cannot be imperilled by constant tinkering with the tariff."

And with a hearty good-day we parted.

California has 2,675 of the giant trees still left, and the largest of these is thirty-three feet in diameter.



### PROTECT THE WORKINGMAN.

Editor Canada Lumberman:

It seems to me that in your article in last month's LUMBERMAN on Mr. Hardy's Lien Act for shantymen, you lean just a little toward the jobber and away from the workingman. If a man has not got the necessary capital to carry him through his season's work, is it right that he should call on the workmen, who are depending upon their wages to provide the actual necessities of life for themselves and family, to supply part of this capital by their labor? To put it another way, should the jobber be encouraged, much less allowed, to speculate on the earnings of the workingman? I think not. Wages should certainly be assured in every case.

Thunder Bay, Ont.

JACK IN CAMP.

### SPARE THE WOODMAN'S AXE.

Editor Canada Lumberman:

I am a lumberman and it is out of the fallen tree that I make my money. All the same I believe the time has come to "spare the woodman's axe" on the forests of this country. I am in accord with the sentiments in your editorial in May LUMBERMAN on forest preservation. We want both to spare the tree and to plant the new tree to fill the gaps that, with a too prodigal hand, we have made throughout the country. I live, when out of the woods, in a farming section, and am something of a farmer myself. There is no question that the yield of the farmer in many Ontario farms to-day is being lessened, because when clearing the country years ago we went too often on the basis that the only thing that a tree was good for was to cut it down, and make some money out of it.

WOODMAN.

Sault Ste. Marie, Ont.

### A VOICE FROM NEW BRUNSWICK.

Editor Canada Lumberman:

If the National Policy means protection, why not protect our forests and our own mill owners, as well as the manufacturers' pockets in other trades? In the county of Madawaska N. B. stock for over 25 millions of shingles yearly has been floated by the mill of one of our men, and manufactured on the American side to feed, clothe and build up American citizens and pay no export duty, while our citizens are driven out of the country to seek labor. Our Minister of Inland who has the honor to represent Victoria and Madawaska by his silence on the export duty, perhaps thinks the lumber resources may as well go to pot wholesale as retail; it is only about forty thousand dollars per year of a loss. Last week's heavy rains will clear all streams of lumber and put thousands into the pockets of those who got the corporative drives. Nature has done her work handsomely, so much the better; water still rising and will be too high. B.

### BETTER A HIGHER EXPORT DUTY.

Editor Canada Lumberman:

It is interesting to note the diversity of opinion as to the advisability of reimposing the export duty on logs. The millmen deem the imposition of the duty as necessary to their existence, while the holders of timber limits are of the opinion that such an act would be prejudicial to their interests. No one denies the fact that American millmen are shipping logs from Canada to their mills in Michigan to be manufactured into lumber. This they would not do, if a quantity sufficient to supply the demand could be obtained at home. From this the inference is obvious, that necessity compels them to have recourse to our forests to procure that which they are unable to obtain from their own. Since of necessity they get logs from Canada, the same need or want would compel them to take the lumber manufactured here, assuming an export duty, practically prohibitive in its nature, imposed. If they must have our logs to supply a present existing demand,

they require lumber, and if they cannot get our logs, they must take our lumber, or go without.

As they come to us in *forma pauperis*, it is for us to determine what shall be done, and as the matter now stands, it would be better for our country as a whole to have a high export duty placed on all logs leaving the Dominion. To this the holders of timber limits would not agree. What about the capital invested in the limits? The best thing would be for our local government, or failing that, the Dominion, to buy back every limit in the country, and control the cutting of the timber. The holders of the limits have never done anything to increase the value of these lands. It is nature's work and not their's. Purchase from them their limits and pay them at going prices. Possibly this might satisfy these gentlemen.

CANADENSIS.

### JAMES SCOTT.

VICE-PRESIDENT OF GEORGIAN BAY LUMBER COMPANY.

ONE of the most successful of the many large and prosperous lumber concerns of this country is the Georgian Bay Consolidated Lumber Company with head offices at Waubauskene and general business offices at Manning's arcade in this city. The Vice-President and business head of the company is James Scott, whose portrait appears in this column.

Mr. Scott was born in Tyrone, Ireland, in 1839, and six years later came with his parents to Canada, settling in Kingston. Here the subject of our sketch spent the happy years of childhood, and those school boy



JAMES SCOTT.

days so fraught with pleasant memories to us all, as years commence to add to years and with them the cares and responsibilities of later life. He was educated in the public schools of the Limestone City, finishing off at Borthwick's private High school, an educational institution, holding then a position similar to the High schools and collegiate Institutes of the present day.

Mr. Scott's first experience in "padding his own canoe" was as teacher in one of the Kingston public schools, becoming shortly afterwards principal of the leading public school in the city. His next step in active life was to become connected with the Royal Canadian Bank, leaving banking with the collapse of this institution, an event yet fresh in the memories of many.

In 1869 Mr. Scott removed to Toronto, taking a position in the Crown Lands Department. But the life of a civil servant, if congenial to some, and doubtless it is, was too monotonous for a man of Mr. Scott's energy and push, and at the end of three years we find him in the midst of the activities of lumbering as book-keeper for the Georgian Bay Lumber Company. Devoting himself industriously to the interests of the Company he was quickly promoted from one position to another, for many years serving as Sec'y-Treas., relinquishing this later to become Vice-President and active business manager of the company.

This position Mr. Scott occupies to-day, and some idea at least of the labor and responsibilities that go with it, may be gleaned by a brief reference to the large business carried on by his company. In 1872 the

business was conducted under the name of the Georgian Bay Lumber Company with mills at Waubauskene and Pt. Severn and business headquarters at Barrie. In 1873 the head offices were removed to Waubauskene and shortly after this the company absorbed the properties of Page, Mixer & Co., of Byng Inlet and also the Collingwood mill known as Horthkiss, Perkar & Co.'s mill. The firm name was at this time changed to the Georgian Bay Consolidated Lumber Co. Five mills are now operated by this company who also own large timber limits. Their output for 1890 consisted of 65,000,000 feet of lumber, besides a considerable quantity of shingles and laths. Additional to this there was taken out three-quarters of a million feet, cubic, square waning timber for the English market. The company run a box factory at Waubauskene where they manufacture boxes for the New York trade to be used in the exporting of coal oil to foreign countries. They turn out 5000 shooks per day.

For sixteen years, until less than three years since, Mr. Scott resided at Waubauskene, at that time removing to this city. Whilst, at no time owing to the extent of his business engagements, occupying any public position, he has always taken an active and intelligent interest in public affairs. He is a prominent member of the Conservative association and at the convention prior to the last general election his name was mentioned in connection with the candidature for East Simcoe. He is a member of the Episcopal church, and is and always has been a total abstainer from intoxicating liquors and ever active, as opportunity occurs, in promoting the interests of the temperance cause.

Mr. Scott's career is a case in point of how a young man by minding his own business, and throwing conscience and energy into every detail of work, can climb from the lowest rung in the ladder to its highest point

### TRADE NOTES.

Messrs. J. Muckleston & Co., of Kingston have leased the extensive works of the late D. McEwen & Co., of that city and intend manufacturing a full line of lumbermen's tools, such as "cant dogs," "peavies," "skidding tongs," etc., in connection with the Brazel's (pat.) snow and side plows, for which they have the sole right in the Dominion. Last winter upwards of 100 of the snow plows were sold to lumbermen in Michigan, where they have already been on the market for some years and where they are fully known and appreciated as an article that will pay for itself several times over during a season. Messrs. McLaughlin Bros., of Arnprior, having bought and fully tested one last winter, have already placed their order for five more and write in most flattering terms concerning them. We are sure that lumbermen generally will find it to their interest to give these plows a trial, and by placing their orders at the earliest possible date insure prompt delivery in the fall. J. Muckleston & Co., are also manufacturing the celebrated "Forest Champion" bob sleigh which is the best of its kind yet introduced in Canada. They also have the latest improvements in all the lines they make, and are extensive dealers in lumbermen's supplies generally. Their catalogue will very shortly be issued. Their advertisement appears in another column of THE LUMBERMAN.

### ALASKA'S ONLY SAW-MILL.

WESTWARD of Loring lies Annette island, upon which is situated the Tsimpsean settlement of Rev. William Duncan, which was removed to Alaska from British Columbia about three years ago. Here is found the only sawmill avowedly producing lumber for sale. This mill is operated entirely by Indians, even the office work and book-keeping being done by them. These people also have blacksmith shops, tin shops, etc., and have erected a cannery, which produces a few thousand cases of salmon annually. In order to establish this settlement, it was necessary to clear the whole area of its covering of forest and undergrowth, and after erecting a town of comfortable cottages, arranged in regular streets and squares, these people are just beginning to make their first attempt at horticulture. Annette island is densely timbered and well stocked with deer: its streams abound in salmon, and the surrounding waters furnish an ample supply of halibut and codfish. An attempt is being made to have this island declared a reserve for the sole use of the Tsimpseans.

## THE NEWS.

## ONTARIO.

—Send us the news of your district.

—The mill at McGregor is closed.

—The mills at Severn Bridge are running full time.

—Stalker's saw mill at Flodden is in full operation.

—Alex. Mustard's saw mill at Brucefield is being refitted.

—Dennis' lumber mill at Schomberg is doing a good trade.

—Men everywhere are now actively at work on the "drives".

—A. Tait of Orillia will cut 2,000,000 feet lumber this year.

The Niagara Glazed Paper Co. is building a mill at Niagara Falls.

—Mr. Dole, shingle mill man of Dorset is starting to cut lumber.

—The Hardwood Saw Mill has been acquired by the Rathbun Co.

—Mr. John Millin has rented Mrs. Keleey's saw mill at Dunchurch.

—The S S Seguin is carrying lumber from Parry Sound to Tonawanda.

—Conlon's mill on Picnid Island has commenced cutting for the season.

—Mr. Ranney's shingle mill at Severn Bridge is shut down for the want of stock.

—Mr. Zuber of Walkerton has removed to Chepstow, where he will run a saw mill.

—New machinery has been put into the saw mill of John McKnight at Pembroke.

—Bronson and Weston, Ottawa, are putting on a night gang and the cut will be large.

—Mr. James Sharpe M. P. P. Burk's Falls, is shoving his shingle and lumber trade.

—J. Mosseau has left Belle River to take charge of a lumber yard in Ridgetown.

—Mr. Vizeneu is putting in a carding mill in connection with his saw mill, at Vars.

—Messrs. Donaldson & Perdue of Bayfield have moved their saw mill to the Sauble line.

—Drinkwater Bros., Orillia, report business good, though prices are lower than last year.

—Thistle, Carswell and MacKeys mill at Calabogie, will it is expected, be a very large one.

—J. D. Shier of Bracebridge mill cut this season 4,000,000 ft. of lumber and 8,000,000 shingles.

—Mr. J. McConchie of Traders La Portage will cut about 7,000,000 feet of logs into shingles this season.

—The Longford Lumber Company's shingle mill at Lakeside, has commenced operations for the season.

—A planing mill is about to be erected at Pt. Credit by Mr. A. R. Gordon who will also open a lumberyard.

—The mill of Peter Shaw, Novan, will cut this year about 1,000,000 feet of lumber and 3,000,000 shingles.

—Buchanan Bros., Staples are ditching around their lands to facilitate getting their timber out of the bush.

—It is expected that a portion of J. R. Booth's big new mill, Ottawa, will be ready for operation early this month.

—The Flesherton saw mill has been purchased by Mr. J. E. Moore, who also proposes starting furniture manufacturing.

—Freshets at Burk's Falls have given some trouble to those working at Sharpe's logs on the north branch of the river.

—Mickle Dymont & Son will cut at Barrie and Bradford 6,000,000 ft. of lumber and at Gravenhurst 5,000,000 feet.

—The staff of hands at Beatty's shingle mill Parry Sound, is greater than any previous season. A large trade is anticipated.

—Cass Bros. of Martinville have opened up business with a large drive of logs, and plenty of sawn lumber of all kinds.

—E. C. Lewis of Elford is actively engaged in shipping lumber to Detroit and other points. His mill is running full blast.

—The Braeside Lumber Mills are not going to commence operations for the season till the end of July or beginning of August.

—Messrs James McLaren & Co., have leased McClymont's mill in Rideau ward, Ottawa and will run it during the summer.

—The Holbert saw mill at Burk's Falls has been so improved as to enable the proprietor to increase the output for shipment.

—The timber drive of Barnett & Co. at Cedar Lake on the Petewawa is in charge of Mr. Ephraim Lalorde, of Ottawa.

—The drives on the Madawaska river N.B., are reported to have started well, their being no lack of water.

—Messrs. Graham, Horne & Co. have removed their saw mill and drying kiln to Fort William from Vermillion Bay.

—A night gang has been put on at McLaren & Co's. New Edinburgh saw mill giving employment to over 100 additional men.

—The Brennan mill property in Huntsville is to be transformed into a tannery. Mr. Beardmore, it is said, has purchased it.

—Mr. T. Hobart, Burk's Falls is cutting this year for J. Sharpe of same place. The cut will be chiefly shingles—about 7,000,000

—A bill is now before the Dominion parliament to reduce the capital stock of the E. B. Eddy Manufacturing company to \$300,000.

—A Listowel public meeting has resolved to form a joint stock company with \$50,000 capacity to build and operate a furniture factory.

—No night gang will be put on at Perley & Pattee's mills the Chaudiere this season, and the firm's cut will be consequently smaller than last year.

—The Shepherd & Morse Lumber Co., the Ottawa Lumber Co. and the Export Lumber Co., have moved into their new offices in Central Chambers, Ottawa.

—A tow of lumber barges containing 3,330,000 feet of sawn lumber, was brought from Ottawa to Montreal on 6th ult., being the second big tow of the season.

—Messrs. McLaren & Co's St Denis Creek drive, appears to have been an unfortunate one from the word "go"—stuck last year, two men drowned this year.

—The annual report of the Owen Sound Board of Trade shows that shipments were made to the States during six months of 1890 of over a million feet of lumber.

—The Severn Bridge mill has been thoroughly overhauled, and an automatic filer and an endless chain carrier has been added among other improvements introduced.

—The table made from the first tree cut in Guelph and owned by the late Mr. Baker has been bought by Mr. Thos. Holliday, who intends to present it to the Mayor of the city.

—The new mill of W. W. Belding, Katrine, is now completed. The cut this year will run from 6,000,000 to 8,000,000 feet of lumber, 5,000,000 shingles and 4,000,000 lath.

—The Parry Sound Lumber Co.'s mill is turning out an enormous amount of lumber daily. The largest cut in one day was 98,000 feet, and the average for two weeks about 90,000 feet per day.

—Mr. Jas. Blaine, blacksmith, has removed from Burk's Falls to Katrine where he purposes to rebuild his steam saw mill and renew his lumbering operations in connection with the smith work.

—From Fergus north in the bed of the Grand River more cordwood, logs, poles and posts have been taken out through the townships of Luther, Arthur, Proton, Waldemar etc. than in any previous year.

—The new band saw from the works of the Stearns Manufacturing Co. New York, and recently placed in the big mill of the Rathbuns at Deseronto, is proving quite a novelty to mill men in that section of country.

—The E. B. Eddy Manufacturing Company have purchased the waste lumber of the season's cut at the Buell, Orr, Hurdman & Co's mills, Ottawa. They require it for steam purposes in connection with the pulp factory.

—Mr. J. B. Miller, president of the Parry Sound Lumber Co. has during the winter had built a lumber barge costing over \$100,000. The boat will be used for the carrying trade and will be the largest lumber barge on the upper lakes.

—Le Canada announces that Messrs. Riopelle & Smith have sold for \$82,500 a timber limit in the township of Ballantyne, to the Moore Lumber company of Detroit. This limit was bought from the Ontario government at auction some years ago for \$42,000.

—A quantity of hickory wood is being shipped from Ridgetown and neighborhood direct to Germany, to be manufactured into rifle stocks for the army. The timber sells for \$16 per thousand, and the freight charges to its destination it is said amount to \$50 more.

—The Whaley Lumber Company of Huntsville are adding two new shingle machines made by Morey & Son of Graven-

hurst, and a new boiler from the factory of Goldie & McCullough. They will manufacture about 3,000,000 feet lumber. An improvement to their mill will be a new siding which is now being laid and which will give them better shipping facilities for the future. Prices are reported about same as this time last year and trade fairly good.

—The Georgian Bay Lumbering Co. are experiencing considerable difficulty in getting their logs down the river. The steady westerly winds retard them on the little lakes.

—The lumbermen of Fergus are having a hard time with their logs, owing to the dry weather. The river is very low. Perry & Black have got as far as Glenlammond dam. Mr. Reed is stuck with his 7,000 ties up above Belwood.

—Large quantities of elm logs are being shipped from Walkerville over the L. E. E. & D. R. R'y for Wyandotte and Detroit. They are taken on that line to the west of the town and rafted either across or down the river. About 200 carloads of timber will be shipped from the slip north of Harrow.

—Messrs. McBurney and Laycock of Gravenhurst operated just two camps the past winter. They expect to cut also 3,000,000 feet lumber this year, which is one half the quantity cut last year. They will also cut 3 million lath. The capacity of their mill is 40,000 feet daily. It is anticipated that this will be their last season on the old limits.

—Heath, Tait and Turnbull of Huntsville will cut 3,000,000 shingles this season. They have been running day and night since middle of April. They will get out about 4,000,000 feet of lumber and have on hand about 8,000,000 logs. Arrangements have been completed with the Edison electric light company to put in about twenty-five incandescent lights into their mill.

—Operations at Mason's lumber mills in the Ottawa Valley are in a very prosperous shape. The firm began operations in 1872. Two years ago Mr. Geo. Mason, senior member and his son, Mr. Wm. T. Mason, bought out the interest of the old firm, and have made big strides since. The cut last season reached almost nine million feet, which it is expected will be exceeded this year.

—The William Hamilton Manufacturing Co., of Peterboro', Ont., have got the contract to supply all the machinery for the Pacific Lumber Company, which is starting a mill at New Westminster, and is to have a daily capacity of about 250,000 feet. This company is also furnishing machinery for the new mill of 75,000 daily capacity at Ladner's Landing, B. C.

—By the will of the late Mr. R. H. Klock of Aylmer, it is understood Messrs. James and Robert Klock succeed to the immense estate connected with his lumber interests. It includes 1,500 square miles of limits. The town and country estate and personal property is divided between the four other members of the family.

—John Milne & Son, Huntsville, are doing a much larger business than formerly. They have been running the mill all winter. They have put in a new broom handle machine, which will enable them to turn out 4000 broom handles daily and propose putting in a machine for the manufacture of pike poles.

—John West of Simcoe has completed and launched the alligator tug "Saginaw" 20 horse power which makes 6 miles per hour on water and half a mile per day over portages &c. She is unequalled in breaking dumps and towing booms, as she anchors and winds in her steel rope tow line, with the same engine and a driver which can be geared slow when drawing herself over the land. The system seems a complete success, and this is the fifth now in use.

—A certificate of partnership has been registered which amalgamates several large lumber interests. The firms amalgamating are Messrs. White, Avery & Co., Messrs. Buell & Orr, of New York and Burlington, and Messrs. Hurdman of Ottawa. The new firm will be known by the name and title of Buell, Orr, Hurdman & Co., in Ottawa, and as Buell, Orr & Co., in New York. The partners are Messrs. A. A. Buell of Burlington; J. C. Orr, New York. F. W. Avery, W. G. White, Robert Hurdman, C. S. Read, W. H. Hurdman, jr. Mr. C. S. Read will act as financial manager. In answer to a reporter, Mr. W. H. Hurdman said: The new firm will not cause any increase in the output this year. The change will effect it afterwards. Messrs. White & Avery will complete their present engagements, and then all new engagements will be in the name of the firm, as will Mr. Buell's at Burlington. Mr. Orr's private business at New York will not be affected. The new firm besides manufacturing will launch into the general lumber business. It is expected that the operations of the firm in the Ottawa valley will be largely increased.



QUEBEC.

—The Eastman Mill Company have started their drive of logs from the landing at the Cartoon.

—A large raft belonging to the Collinsby Rafting Co. was broken to pieces while going through the Lachine Rapids.

—The Pulp mill, at Buckingham, sold recently to an American firm is doing a large business. Mr. Scott is the manager.

—Price Brothers, of Quebec, the famous lumber kings, have cut no less than 160,000 pine logs in Montmagny woods during the past season.

—A timber raft belonging to Calvin & Co., Cardinal, Ont., went to pieces during its passage down the Lachine Rapids on 3rd ult. Fourteen men were on it and had a narrow escape from drowning.

—Considerable lumbering has been done this season at Glen Sutton. A large quantity of hewn birch has been taken out to be shipped to England.

—The contract has been let for the building of a new paper mill, at Sherbrooke, Que. The pulp mill at the same place is being overhauled and enlarged.

—Plans are being made by Architect Ellsworth, of Holyoke, Mass., for a new mill to be erected by the Royal Pulp and Paper Co., of East Angus, during the summer. The mill will be erected on the St. Francis River and will be on the direct line of the Quebec Central Railroad. The company has a capital of \$300,000, and the general manager is James D. Finlay, formerly of the Winona and Wauregan paper mills. George Van Dyke, president of the Connecticut River Lumber Company is a director.

NEW BRUNSWICK AND NOVA SCOTIA.

—Lumbermen are anxiously looking for rain to bring the winter's lumber cut out of the streams.

—Grants for 36,669 acres of Crown Lands were issued by the Crown Land Office of Nova Scotia last year.

—The Pulp Mill, at Mill Village, N. S., is now running night and day, giving employment to twenty-five men. Mr. J. Hughes, of Halifax, is manager.

—There is no freshet in either of the great branches of the Miramichi, N. S., and the lumber drives are making very slow progress. Rain and warm weather are wanted.

—Mr. A. Gibson has in use at the Nashwaak, N.S., seven scows of 110,000 carrying capacity which will be used in loading deals and do away in at least part with the wood boats that heretofore did the work.

—Mr. W. H. Murray, the well-known lumberman, of Fredrickton, N. B., while on his way to Quebec a few days since had \$1,500 stolen out of his sleeping berth. The act was afterwards traced to the colored porter and all the money save about \$100 was recovered. The thief was arrested at Halifax, N. S.

—Some scoundrel who should be severely punished cut away the boom at Cameron Bridge, Black River, N. S., in such a manner as to leave it apparently safe, but yet ready to break with a very slight strain. The boom-stick which holds the strain at the centre of the bridge span had been cut almost through with an axe, but enough wood was left intact to hold it in position.

—The annual report of the crown lands department, New Brunswick, shows that during 1890, there was cut:

	FEET.
Spruce and pine logs.....	95,539,612
Hemlock logs.....	12,139,948
Cedar logs.....	4,716,201
Hardwood logs.....	890,462

In addition there was cut a large quantity of cedar poles, cordwood, etc. The total stumpage charged in 1890 is \$111,475.37. There is an increase of about \$3,000 in the stumpage receipts, and of \$8,715.59 in the total territorial revenue.

MANITOBA AND THE NORTHWEST.

—The Bulmer Mills, at Rat Portage, Man., are run by Cameron & Moffatt.

—J. McConachie's shingle mill at Rat Portage, Man., will run night and day this summer.

—A new boiler and engine has been placed in the mill of J. Whiteside, Rat Portage, Man.

—Carven & Kennedy have put in 45 lights 32 candle power each in their mill at Norman, Man.

—All the mills at Norman, Man., some six or eight large concerns, are doing a brisk trade.

—The Western Lumber Company, of Rat Portage, Man., has opened a yard at Brandon, Man..

—Joseph Davis, of Winnipeg, lumberman, is a regular purchaser of lumber at mill points along the Northern Pacific, making shipments to points over the line.

—C. A. Larkin, of Brandon, has sold his mill to L. J. Ashley.

—A lumber yard has been opened at McGregor, Man., by J. W. Thompson.

—Messrs. Arthur & McRae's mill will saw a million feet of lumber at Berth, Man., this season.

—The Malcolm Thompson cut of logs at Rapid City, Man., will be sawed by Messrs. A. & W. Stewart.

—C. A. Christie, of the Brandon saw mills, has seven million feet of logs coming down the river for his mill.

—Selkirk, Man., is to have a paper mill. Mr. D. MacArthur, of Winnipeg, proposes erecting one on his property recently occupied by the large saw mill there.

—A lumber yard has been opened at Alexander, Man., by Alex. Carman, late manager for Dick, Banmy & Co., of Portage la Prairie, Man.

—The government contract for the supplying of timber for the works at the locks at Peninsula Creek has been awarded to Whiteside & Young, of Rat Portage, Man.

BRITISH COLUMBIA.

—A saw mill will be established at Sycamouse.

—Murray Bros. have opened a lumber yard at Mission City, B. C.

—Collett & Hunter are about to establish a saw mill at Nicola.

—British Columbia lumber dealers are doing a good Australian trade.

—Two beautiful sticks of lumber, 84 feet long, were cut at the Brunette mills.

—The Brunette mills are making heavy shipments of dressed and rough lumber weekly.

Morse's mill, at Vancouver, will be improved, and the capacity largely increased to about 200,000 feet per day.

—The Mechanis Mill, at North Arm, is running fulltime, and the firm are making a specialty of fine interior finishings.

—The Brunette Mills Company, at New Westminster, are building a large scow and a fine boat for their lumber trade.

—Logs over five feet in diameter and perfectly sound and good have been cut at the Brunette mill, New Westminster.

—A shingle mill is in course of erection at False Creek by W. L. Tait, of Winnipeg, Man. It will have a daily capacity of from 35,000 to 40,000 ft.

—Mr. Jas. Tretheney, of Mission, is about to erect a saw mill on Elk Creek where he has acquired a fine tract of land with a good water power situated conveniently.

—At E. Ward's shingle mill, North Arm, a large steam boat, 60 ft by 14 ft. beam, is being built for Mr. Ward, to be used by him for towing purposes.

—The business of the Royal City Planing Mills Company, Limited, at New Westminster and Vancouver, and the Hastings Saw Mill Company, Limited, of Vancouver, have been acquired by the British Columbia Mills Timber and Trading Company, and will in future be carried on under that name.

—The Moodyville Saw Mill Company are preparing to put twelve new boilers in their mills. They have been designed by S. J. Randall, machinist for the mills, and are of a shape especially adapted for utilizing the heat obtained from sawdust and mill refuse.

—The Port Discovery saw mill has stopped work, owing, it is said, to dullness in the foreign trade. According to mill men, the war in Chili has had a depressive effect on the industry, and they look forward to brighter times when that trouble shall have been settled.

—The capacity of the Rock Bay saw mill at Victoria, is to be increased to 80,000 feet per day. This will necessitate the putting on of a night gang and running night and day. An electric plant has been put in for the purpose of lighting the mill.

—Negotiations are on foot for the formation of a company with extensive capital, to construct and operate a line of sailing ships in connection with the Chemainus saw mills, whose output is expected to reach every quarter of the globe. This company is separate and apart from the saw mill company, which will also have its own ships.

—At Golden the Upper Columbia Navigation & Tramway Company are building a saw mill, with a capacity of 60,000 per day. In connection with this is the Kootenay mail line of steamers, which run from Golden to Windemere and tap East Kootenay, which is known to be the richest country in minerals and also for ranching in British Columbia. The company is an English one, with a directorate composed of Lord Norbury, Hon. T. B. H. Cochrane and E. P. Armstrong, and will expend this season about \$100,000 in tramways and other improvements generally.

—Messrs. Johnson, Walker & Flett, of Victoria, have proposed of their planing mill in that city to a Seattle firm for consideration of \$40,000. The Seattle people will continue the operation of the planing mill, and Johnson, Walker & Flett will erect a large saw mill on the premises adjoining it.

—The boiler, engines, large circular rig, etc., for the new saw mill of the North Pacific Lumber Company, at Earnet, B. C., which will be one of the largest on the Pacific Coast is being supplied by the celebrated Waterous Co., of Brantford, and another part of the machinery by the Wm. Hamilton Co., of Peterborough.

—The final arrangements of the sale of the Moodyville mill have been executed. The sale was made to some European capitalists, and includes the mill, the timber limits and all the property belonging to the late company, with the exception of the vessel, Etta White. The amount paid was about a million dollars. The mill will shortly be greatly improved and enlarged.

—The Royal City mills, New Westminster, are building a line of railway from their limits on Mud Bay to Hall's Prairie, where it will connect with the Great Northern. The length of the line will be about six miles. Over this line and the Great Northern, the logs from the Mud Bay camp will be carried to Port Kells, where they will be unloaded into the water, boomed, and towed to the mills in New Westminster.

—There are forty-one saw mills now built or in course of erection in this Province. The capacity of the mills at Vancouver has been increased to 210,000,000 feet yearly and the actual capital invested represents \$1,750,000. For the year the actual cash value of the output was in round numbers, \$1,000,000, and the output in feet about half the capacity, namely 100,000,000 feet. The number of men employed by the various mills at Vancouver is 1,900. The finest growth in timber is on the coast and in the Gold and Selkirk ranges. Millions and millions of feet of timber, locked up for centuries, have now become available for commerce.

UNITED STATES.

—The widest plank on earth is on exhibition in Humboldt, Cal. It is 16 feet in width. It will be among the Humboldt exhibits at the World's Fair.

—It is estimated that the production of hemlock lumber in Pennsylvania will reach 800,000,000 feet in 1891.

—The old log cabin in St. Louis county, Mo., which Gen. Grant erected with his own hands out of timber cut and hewn by himself, is to be removed to Chicago as one of the attractions of the World's Fair.

—A shingle machine that will turn out 90 shingles per minute is awaiting a patent at Dubois, Pa.

—Texas has 45,302,500 acres of timber land, with 67,508,500,000 feet of standing timber.

—According to the Post, of Chicago, the pine stuffed handle in that market last year amounted to 1,900,000,000 feet. It is believed that the present year's consumption will far exceed that of last year.

—In the decade from 1880 to 1890 the value of the output of forest products from the southern states has more than doubled. In 1880 it footed up \$46,977,000 while in 1890 it had increased to \$102,122,000 being an increase of \$55,145,000.

—The big pine trees don't seem to be all cut in Michigan. Rust Bros. found one of these monsters in Clare county during the winter that scaled 5,162 feet, one 16-foot log scaling 1,204 feet.

PERSONAL.

Mr. Andrew Miscampbell, M.P.P., was in town during the past week. Lumbering, he says, is quiet in the Midland district.

A. L. Patching, of Windsor, has been down in Tennessee for some time where he has made large purchases of lumber and mineral lands.

Mr. James Corcoran, of Stratford, managing director of the Canadian Pacific Lumber Company, has been spending the past month in British Columbia selecting a site for a new mill. It was thought that New Westminster would have got the plum, but later reports state the mill will be located at Fraser River.

THE LUMBERMAN had the pleasure of a call on the 27 ult., from Mr. A. McDonald, of Peterboro'. He says a fair trade in lumber is being done this season. The town has taken on quite a boom as a result of the building of the Edison Electric Light Works.

James Quigg, an old time packer and miner, of the Cariboo Mining District, B. C., is dead. Before leaving New Brunswick, in 1854, he followed tow-boating and lumbering for a living, and is said to be an expert river driver. In 1861 he was in Minnesota, and was at Red Wing during the Indian massacre. From Minnesota he drifted up the Red River valley to Winnipeg, and from Winnipeg crossed the plains to British Columbia. He was a well-known character in Cariboo.

TRADE REVIEW.

Office of CANADA LUMBERMAN
May 30th, 1891.

COMPLETE quietude appears to exist in trade circles at the present time. Dealers are ready to sell but buyers are scarce. Everyone is anxious for the good time that the 'morrow is expected to bring, only the 'morrow is slow in getting here.

Shipments to the States are hardly as brisk as last month, the best of the trade appearing to be over.

British Columbia trade is curtailed by the condition of matters in South America, which has been an important shipping point for dealers on the Pacific coast. And there are not any signs that the Argentine Republic will get on its feet again in a hurry.

Our news columns indicate a fairly active season among the mills, and we hear of at least one large lumber company in the Dominion, that by shrewd watching has been able to open out fresh fields for some stocks this year.

A despatch from Michigan states that Dwight Cutler, of the Cutler & Savidge Lumber Company, Spring Lake, Mich., who has been quietly buying up good timber lands in the Queen's domain, until he now has upwards of 50,000 acres in the Georgian Bay regions with a stumpage estimate at 200,000,000 feet, will as soon as the company's operations in Michigan are completed, transfer the entire plant to Canada.

UNITED STATES.

Labor strikes and boycotts are playing sad havoc with lumber trade in some parts of the States, more particularly New York. The Lumber Trade Journal of that city, always careful in its conclusions states: "The uncertainty attending the attitude of labor, it is safe to say, has put back and delayed hundreds of thousands of dollars worth of building in this city, and in figuring up their loss in wages, we wish the laboring men would take cognizance of this fact.

From Boston comes word that the weather is fine, but it has not proved an incentive to trade. Spruce is abundant this season, the shingle trade is fair; popular, more in demand than for five years. Albany makes a more cheery showing. Notwithstanding the New York trouble a fair trade is doing.

FOREIGN.

A steady under-current of trade is being felt in the British market. The continental markets are deriving strength from the English demand. As to prices, no alteration is to be noted, the advance being still confined to 4th and 5th quality of prime makes, and to whitewood, which continues to find a steady sale at about 5s increase on the figures accepted in January.

Messrs. Denny, Mott & Dickson, of London, Eng., under date of May 4th, report: "that the very moderate stocks of Canadian oak, yellow pine and elm continue to move off slowly. Business for next season's supplies continues very difficult to arrange as the prices required by Quebec shippers show very little prospect of a margin of profit to buyers on this side, whilst the demand for consumption continues so quiet.

failing to buy at "bottom" rates, and a languid hand-to-mouth demand is the result.

A Melbourne (Australia) timber report of March 18 says: Our wholesale markets have been rather more active than for a few months past, and sales have been somewhat heavier. The firmness of holders has improved values for some lines, but there is a feeling among merchants that the winter trade is going to be quiet, and they are therefore not inclined to buy freely.

Toronto, Ont.

TORONTO, May 30, 1891.

CAR OR CARGO LOTS.

Table listing various lumber products and their prices in Toronto, Ontario, including items like 1 & 1 1/2 in. Cut up and better, 1x10 & 12 dressing and better, etc.

YARD QUOTATIONS.

Table listing yard quotations for various lumber products, including Mill cull boards & scantling, Shipping cull boards, Scantling & joist, etc.

Ottawa, Ont.

OTTAWA, May 30, 1891.

Table listing lumber prices in Ottawa, Ontario, including Pine, 1st qual., 2nd, shipping culls, etc.

Montreal, Que.

MONTREAL, May 30, 1891.

Table listing lumber prices in Montreal, Quebec, including Pine, 1st quality, 2nd, shipping culls, etc.

Oswego, N. Y.

OSWEGO, May 30, 1891.

Table listing lumber prices in Oswego, New York, including Three uppers, Pickings, No. 1 cutting up, etc.

Siding.

Table listing siding prices, including 1 in siding, cutting up, 1 1/2 in selected, etc.

1x10 Inch.

Table listing 1x10 inch lumber prices, including 12 & 13 ft, mill run, mill culls out, etc.

1x12 Inches.

Table listing 1x12 inch lumber prices, including Mill run, mill culls out, Dressing and better, etc.

Shingles.

Table listing shingle prices, including XXX, 18 in pine, Clear butts, pine, etc.

Pickets.

Table listing picket prices, including No. 1, 1 1/2 x 1 1/2, No. 1, 1x3, etc.

Lath.

Table listing lath prices, including No. 1, 1/2, No. 2, 1 1/4, No. 1, 1/2, etc.

St. John, N. B.

ST. JOHN, May 30 1891.

Deals, Boards, Scantling, etc.

Table listing lumber prices in St. John, New Brunswick, including Spruce deals, Pine, Deal ends, Scantling, etc.

Shingles.

Table listing shingle prices, including Spruce, extra clear, No. 1 extra, etc.

Clapboards.

Table listing clapboard prices, including Pine, extra clear, 2d clears, etc.

Flooring, Dressed.

Table listing flooring prices, including 6 in. No. 1, No. 2, 4 in. No. 1, No. 2, etc.

Miscellaneous.

Table listing miscellaneous lumber prices, including Staves, Heading 17 in. per pr., 18 in., 22 in., etc.

Albany, N. Y.

ALBANY, N. Y., May 30, 1891.

Hemlock.

Table listing hemlock prices, including Boards, 1x10 in. each, Joist 4x6, etc.

Pine.

Table listing pine prices, including 2 1/2 in. and up, good, 4ths, Selects, Pickings, etc.

Shingles and Lath.

Table listing shingle and lath prices, including Shingles, shaved pine, 2d quality, etc.

Buffalo and Tonawanda, N. Y.

BUFFALO, May 30, 1891.

Norway.

Table listing Norway lumber prices, including Clear, 1 in. & clear, Dressing, 1 to 2 in. all widths, etc.

White Pine.

Table listing white pine prices, including Up'rs, 1 & 1 1/2 in., 1 1/2 to 2 in., etc.

Shingles.

Table listing shingle prices, including XXX, 18-in., XX, 18-in. or C. B., etc.

XXX cut.

Table listing XXX cut prices, including XXX, sawed, C. B., No. 2, Thick cut, etc.

Boston, Mass.

BOSTON, May 30, 1891.

Western Pine—by car load.

Table listing western pine prices by car load, including Uppers, 1 in., 1 1/2, 1 1/2 & 2 in., etc.

Eastern Pine—Cargo or Car Load.

Table listing eastern pine prices by cargo or car load, including Nos. 1, 2 & 3, 4, 5, etc.

Spruce—by Cargo.

Table listing spruce prices by cargo, including Scantling and plank, random cargoes, Yard orders, etc.

Lath.

Table listing lath prices, including Spruce by cargo, etc.

Shingles.

Table listing shingle prices, including Spruce, Pine, 18 in. extra, etc.



**FIRES.**

Forest fires in Quebec.  
 Forest fires in New Brunswick.  
 Morley, Mich., containing eight saw mills is in ashes.  
 Heavy losses of lumber through bush fires in Wisconsin.  
 A loss of \$300 by fire in Withrow & Hillocks lumber yard, Toronto, on 9th ult.  
 The carpenter shop of Cameron & Kennedy's mill at Rat Portage, Man. Loss \$250. Insured.  
 Miles of woods have been ablaze at Preston, Pine Lake, and the other side of the North-West Arm, near Halifax, N. S.  
 Twenty-five thousand acres of pine lands in New Jersey. At a rough estimate it is said the losses will be at least \$1,000,000.  
 Every saw mill on the mountains between Bellefonte and Lewisburg, Pa., has been destroyed, and millions of feet of valuable timber.  
 The large planing mill of Jacob Lovell, at Niagara Falls, was destroyed by fire on the night of the 8th ult. Loss \$6,000. No insurance.  
 The saw mill of Mr. N. L. Lusty, at Rodney, Ont., was completely destroyed by fire on 1st ult. Loss about \$3,000; no insurance.  
 Carrick and Bros.' shingle mill at Fawham, Ont., together with a million and a quarter feet of lumber. Loss \$12,500. No insurance.  
 Awful bush fires along the line of Kingston & P. Ry. taking in Ormpat, Lavant and Wilbur. A great deal of cordwood cut last winter has been destroyed.  
 Terrible bush fires and great suffering in Pennsylvania, taking in the pretty little farming towns of Austin, Costello, Galeton and Moore's Run, in Potter county.  
 Millions of dollars worth of damage has been done by the forest fires in the Michigan lumbering districts. Nothing like it since the disastrous fires of 1881.  
 The saw mills owned and run by A. B. Saylor, at Bloomfield, Ont., have been completely destroyed by fire. Loss \$4,000: partly covered by insurance.  
 About twenty-five acres of standing wood belonging to the Rathbun Company on Wm. Green's place, Kennebec, Ont., was destroyed by fire two weeks since.

A row of seven new houses, belonging to William Stewart, owner of the West Toronto Junction planing mill, were completely destroyed by fire the early part of the past month.

A fire at Tasker's switch, Gravenhurst, destroyed a million of lumber belonging to John T. Harvie and about the same quantity belonging to Robt. Thompson, of Hamilton. Both losses are fully covered by insurance.

At Winona, Minn., the entire plant of the Schroth & Ahearns Mill Company went up in flames. The mill, warehouse and three blocks of lumber were burned. The fire started in the wheel pit of the planing mill. Loss \$100,000.

The thriving lumbering towns of Otia, Fields and Park City, Mich., have been wiped off the earth by the flames, and all that remains of Lilley are the hotel and depot. Heavy losses were made in the destruction of several large saw mills.

One of the largest fires known for years south and west of Austin, Pa., on the lands of F. H. & C. W. Goodyear. It is estimated 30,000,000 feet of logs and 10,000 cords of bark have been destroyed, besides 10 miles of tram railway.

Aggregate losses of \$500,000 have been made by fires at Long Island, L. I. The losses of the Export Lumber Company will probably reach \$250,000; the H. F. Burroughs Company's lumber yard, \$200,000; the Whiting Lumber Company, \$5,000; MacIntosh & Co., lumber, \$25,000.

A disastrous bush fire broke out in the pine woods of Messrs. Kennedy & Staples north-east of Bowmanville, Ont., on the Pine Ridges on 7th ult. The fire, it is thought, caught from the engines on the C.P.R. A large quantity of cordwood belonging to Messrs. Ashley & Staples was consumed. The injury to the standing pine will be very great.

At St. Anthony, N.B., on the line of the Buctouche and Moncton Railway, on the night of the 10th inst., a large quantity of valuable lumber, consisting of ash and other hardwoods, spruce, pine and hemlock, manufactured at the mill of Joseph Paulin and belonging to himself and others, was consumed by fire, supposed to have been in the sawdust for two or three days. The lumber was valued at \$1,800 and is a total loss; no insurance.

**CASUALTIES.**

A man named Laflamme was killed in the saw mill of Shearer & Co., at Montreal, Que., on Monday 4th ult.

Mr. Robert Rusk of the Cedar Mill, Deseronto, had a close call on 15th ult., having been thrown quite a distance by some of the machinery, landing near the saws, and having his right leg severely bruised.

Mr. Geo. Shoaff, of James Sloan's shingle mill at Melancthon Station, had his hand badly lacerated on the 12th ult.

An accident occurred in Playfair's mill, Sturgeon Bay, early in May, resulting in the crushing of the foot of a Mr. James Fallis.

A teamster named Alex. Simpson, an employee of the Longford Lumber Co., at Orillia, was killed a week ago by a runaway team at the mills.

Charles Sisson, a logger at Bickley Bay, Caden Channel, B. C., committed suicide on 6th ult., by cutting off his arm and bleeding to death.

John Kennedy while landing logs on Barren River, N. B., on Wednesday, 6th ult., was crushed to death by the logs giving away and taking him along with them.

A cruel joke was played on an employee of the saw mill at Walton, Ont., a few days since, in loading a pipe with gunpowder, resulting in badly burning his eyes and face.

A young man named Abraham, while working at a frame saw in the Royal City planing mills, New Westminster, B.C., lost one finger and had two others severely injured.

On May 15th, Hazard Hull, a saw mill owner of Thamesford, Ont., was running a circular saw when the board he was ripping was thrown in some manner so as to strike him on the stomach. He died the next day. He was 76 years of age and highly respected.

The tug "Eleanor," belonging to McWilliams & Gildersleeve of Kingston, sank near Pigeon Island on Lake Ontario, the second week in the month, while on her way from Oswego to this city with a tow of barges, light, to be loaded with lumber. No lives lost.

A man named Gagnon, a cook in a shanty at Nipissing Village, was found hanging to a beam in the shanty a few mornings ago. He left a note in his pocket saying no one was to blame, that he had been sick for four months and was tired of life. He was married about two months ago.

John McConachie, of Huntsville, Ont., has been in hard luck during the month. On a Monday he lost a horse valued at \$350. An hour or so after the horse died he went to his store for some coal oil and found the barrel upset and the oil all run out. The evening of the same day word was brought to him that the dam built for running his logs down the Boyne creek at Dwight had busted, the water he had been saving all spring had run away and his logs were up the creek high and dry on the bank.

Luck is a good thing if you put the letter P before it.

**WANTED—TO BUY.**

GOOD Canadian Timber Limits and Georgian Bay saw logs. Address, BEN BIRDSALL, Whitney Building, Detroit, Mich.

**WANTED.**

EMPLOYMENT or partnership in lumber business, by man of large experience in manufacturing and shipping. Ready by 15th May. High references. Address, R. B., CANADA LUMBERMAN, Toronto.

HARDWOOD lumber, bought, sold or received on consignment, TUCKER DAVID, lumber commission merchant, 202 Eleventh Ave., N.Y.

**WANTED IN 1891.**

ANY QUANTITY OF CEDAR TELEGRAPH POLES at shipping points. Terms cash. Apply to J. HARRISON HARVEY, Cobocok, Ont., purchaser for H. D. McCAFFREY, Engineer and Contractor of Telegraph lines, Oswego, N.Y.

**RAILS AND CARS FOR SALE.**

Light Steel Rails for Tramways; good order. Cars for lumber, cheap. JOHN T. GARTSHORE, 49 Front St. West, Toronto.

**WANTED.**

QUEBEC BIRCH—Those who can furnish choice lumber are invited to correspond with JOHN S. MASON & CO., 240 Eleventh Avenue, New York City.

**HIGH CLASS**

**Saw Mill Machinery FOR SALE.**

- One 7 ft. 6 in. Slabber } with all ways
- One 6 ft. 6 in. Slabber } and blocks
- One 6 ft. Slabber } complete.
- One 5 ft. 6 in. Slabber }
- One 50 in. improved } complete with
- Wicks Gang, } shaft, feed work
- One 40 in. improved } & all chains, rollers & frictions.
- Wicks Gang. }
- Two Stearns Double-Headed Edgers, with all shafts, pulleys and hangers complete.
- One Stearns Single Edger.
- One large Stearns Circular Mill, with Top saw for cutting timber or logs, 40 ft. carriage, 90 ft. track, 4 sets of blocks.
- Three sets of Trimmers.
- Two Re-saws.
- Three Covill Patent Automatic Filing Machines.
- Three Gang Lath Mills and Conveyors.
- Two Gang Lath Butters.

This machinery is all first-class, being used in our large Saw Mill here, cutting at the rate of 290,000 to 300,000 feet of lumber per day, it can be seen in place here until the 1st week in July next, and is now offered for sale solely because we are RETIRING FROM THE LUMBER BUSINESS.

**THE E. B. EDDY CO.,**  
 HULL, CANADA, May, 1891.



THOS. WHALEY, President. W. E. HUTCHINSON, Sec.-Treas.

**The Whaley Lumber Co.**

OF HUNTSVILLE, ONT. (LIMITED)

Manufacturers of

**White Pine Lumber, Bill Stuff, Lath and Shingles ALSO HARDWOOD LUMBER.**

All orders promptly attended to. First-class facilities for shipping. CORRESPONDENCE SOLICITED.





**A. M. DODGE & CO.**  
**M**ANUFACTURERS of and Wholesale dealers in all kinds of Lumber, Lath and Shingles. Tonawanda, N. Y.

**COWPER & GREGORY.**  
**R**ECEIVERS and Forwarders of Lumber, Lath, Shingles, &c. Unexcelled facilities for shipping by canal or rail. Tonawanda, N. Y.

**CHEESMAN DODGE**  
**T**IMBER and Lumber Merchants. Ship and Boat stock, Railroad Ties, &c. Office, 16 West Seneca Street, Buffalo.

**EMMET FLEMING**  
**I**NSPECTOR and Commission dealer in Lumber. Office, 251 Louisiana Street, Buffalo, N. Y.

**LAYCOCK LUMBER CO.**  
**M**ANUFACTURERS of Pine, Hemlock and Oak Timber up to 55 feet in length. Saw Mills: Ackley, Pa., Black Rock, N. Y., Gravenhurst, Ont. Office, corner Main and Seneca Sts., Buffalo, N. Y.

**J. & T. CHARLTON**  
**W**HOLESALE dealers in Masts and Spars, Canada Round Pine, &c. Tonawanda, N. Y.

**WILLARD W. BROWN.**  
 202 Main Street, Buffalo, handles all kinds of Hard Woods.

**A. P. & W. E. KELLEY CO.**  
**W**HOLESALE Lumber dealers. Yards at Tonawanda and Chicago. Correspondence invited.

**C. P. HAZARD.**  
**W**HOLESALE dealer in Lumber, Shingles, Lath and Fence Posts. Correspondence invited from the Canadian trade. No 92 River Street, Buffalo, N. Y.

**L. A. KELSEY LUMBER CO., (Ltd.)**  
**M**ANUFACTURERS and dealers in Hardwood Lumber of all kinds. Describe stock and write for prices. Office Tonawanda, N. Y.

**BOVEE & HOWDEN**  
**M**ANUFACTURERS and Wholesale dealers in Hard and Soft Wood Lumber. Holders of Canadian stocks are invited to write for quotations. Offices at Tonawanda and Le Roy, N. Y.

**THE TONAWANDA LUMBER CO.**  
**M**ILLS at East Tawas, Mich.; office 106 Main Street, opposite N. Y. C. and H. R. R. R. Station, North Tonawanda, N. Y.

## Cash for Lumber

W. N. McEachren & Co.

Wholesale dealers in all kinds of

## HARDWOOD LUMBER

NO. 3 DOCK  
 TORONTO

WRITE US FOR PRICES AND SIZES TO CUT.

WE PAY CASH WHEN LOADED ON CARS.

HERBERT G. ROSS. Box 273. REGINALD C. BLAKER.

## N. G. ROSS & CO.

Real Estate, Fire and Life Insurance, Shipping and General Commission Agents.

Timber Limits and Farming Lands a Specialty.

A.B.C. Code, Cable address, "Ross."

NEW WESTMINSTER. - - - B. C.

CORRESPONDENCE SOLICITED.

## LUMBER

### TRUCK \* WHEELS.

\*\*\*\*\*

## The Montreal \*

## \* Car Wheel Co.

MANUFACTURERS OF

CHARCOAL IRON CHILLED

## RAILROAD WHEELS

Offices: New York Life Insurance Building, Montreal.

Works: Lachine, Quebec.

\*\*\*\* \*

WE make a Specialty of Wheels suitable for the requirements of Lumbermen and Street Car Service, and can supply them Bored, Finished and Balanced.

CORRESPONDENCE SOLICITED

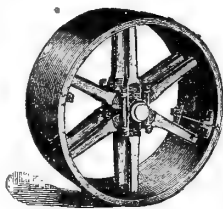

Menasha Hickory Pulleys

We make the only hardwood bent rim spoke arm split pulley, only small split pulley, only wooden hangers in the market. Send for discounts & circulars.

Menasha Wood Split Pulley Co. MENASHA, WISCONSIN.

## THE MONARCH BOILER AND HERCULES ENGINE.

(PATENTED)

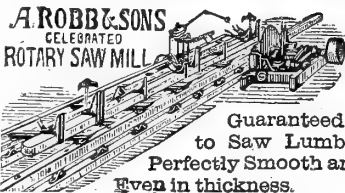

Guaranteed to Saw Lumber Perfectly Smooth and Even in thickness.

Portable from 6 to 70 horse power. Surpass portable steam power heretofore produced for strength, durability, compactness, and the ease with which they can be moved.

The 70 horse power can be taken over the roughest roads, or into the forest, and set up as easily and quickly as an ordinary 20 horse power portable engine, and as firm as a brick-set stationary engine. Engines and boilers of every size and description. Rotary Saw Mills, Shingle and Lath machines, Law Grinders, Planers, etc. Mill machinery and supplies of every description. Every boiler insured against explosion by the Boiler Insurance & Inspection Co. of Canada. Write for circulars.

A. ROBB & SONS, Amherst Foundry and Machine works. Amherst, N. S.

ESTABLISHED OVER 40 YEARS.

DALTON McCARTHY, President. A. ECKARDT, Secretary. JOHN McGREGOR, Manager.

## Toronto and Midland Mfg Co.

(INCORPORATED.)

## Wholesale \* Lumber \* Dealers

AND MANUFACTURERS OF

## DRESSED LUMBER, FLOORING

Ceiling, Sheeting, Siding, Shelving, Mouldings of all Descriptions.

Office and Yard:

FOOT OF SPADINA AVE., - TORONTO.

Planing Mills: MIDLAND, ONT.

## PORTER, ROBERTSON & CO.

STOCKS  
 STRIPS  
 SIDINGS  
 BILLSTUFF

WHOLESALE

## LUMBER

DEALERS

HARDWOODS  
 HEMLOCK  
 SHINGLES  
 LATH, ETC.

Millichamp's Buildings,

35 \* Adelaide \* Street \* East,  
 TORONTO.

YARD: NORTHERN DOCK, FOOT OF BATHURST STREET.

## NAPANEE CEMENT WORKS

— MANUFACTURERS OF —

## Hydraulic Cement

PARTICULARLY adapted for Dams, Smoke Stacks, Foundations, Culverts, Cisterns, Cellars, etc.

ENDORSED BY LEADING RAILWAYS AND CONTRACTORS.

## ROACH \* LIME,

For Building, Plastering, Gas Purifying, Paper Making, &c.

## THE RATHBUN COMP'Y,

DESERONTO, ONT.,

MANUFACTURERS OF

## \* TERRA \* COTTA \* FIRE-PROOFING \*

For Use in Old and New Buildings.

Endorsed by Leading Architects. Absolutely Fire-proof. About as Cheap as Wood or Brick. Weight One-Third that of Brick. Does not Crack on application of Heat or Water.

Deadens Noise. Gives Warmth in Winter; Coolness in Summer.

## Galt \* Machine \* Knife \* Works.



## MACHINE KNIVES

OF EVERY DESCRIPTION FOR

Planing, Moulding & Stave Cutting.

SEND FOR PRICE LIST

PETER HAY, - - - GALT, ONT.

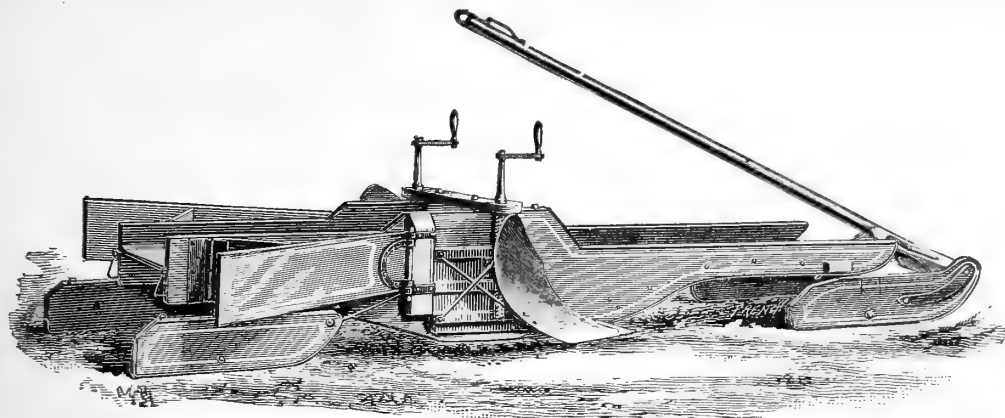

**J. MUCKLESTON & CO.**

Manufacturers of

RED TOP LINE

**LUMBERMEN'S TOOLS**

And Sole Licences for the Manufacture in the Dominion.

Can Dogs  
Pawies.  
SKIDDING TONGS.  
Pike Poles.  
Coldshuts.

**Brazel's Pat. Snow and Sidewalk PLOWS.**

\* \* **LUMBER BOB SLEIGHS.** \* \*

**Investment Bonds.**

**THE DOMINION SAFE DEPOSIT WAREHOUSING & LOAN CO.,**

Head Office—The Canadian Bank of Commerce Building, King St. W., Toronto. **LTD.**

**CAPITAL, ONE MILLION DOLLARS.**

**DIRECTORS.**

W. D. Matthews, Esq., President. Henry W. Darling, Esq., Vice-Pres.  
John I. Davidson, Esq. S. F. McKinnon, Esq. G. B. Smith, Esq. M.P.P.  
H. W. Nelson, Esq. J. P. Clark, Esq. J. H. Starr, Esq.  
M. C. Cameron, Esq. Robert Kilgour, Esq. Alexander Nairn, Esq.  
Thomas McCracken, Esq. Robert Davies, Esq. Eugene O'Keefe, Esq.  
Aaron Ross, Esq.

This Company is now issuing \$100, \$200, \$300, \$400 and \$500 investments in bonds, payable in five, ten and fifteen years from date of issue, with participation in profits, affording all the advantages of compound interest accumulations on small sums of money. These bonds are the obligations of this Company and are specially protected by a sinking fund, invested in first-class real estate mortgages. They are plain definite contracts, subject to no contingencies whatever, are non-forfeitable after one annual payment, with values definitely stated thereon. For a small outlay they secure a fixed and generous return.

To bondholders who complete their contracts the Company guarantee compound interest at the rate of Four Per Cent. Per Annum.

The Company is prepared to receive applications from reliable agents at all points where it is not already represented.

**WM. KERR, Manager**

The Safe Deposit Vaults of the company cannot be surpassed for absolute security. Call and examine or write for circular

80 H.P. CUT OFF COUPLING.

**GRIP**

Pulleys & Cut off Couplings.

10 x 3 TO 10 x 30

SPLIT OR SOLID

GUARANTEED

AFTER USING YOU WONDER HOW YOU MANAGED WITHOUT IT.

**WATEROUS ENGINE WORKS** Brantford, Can.

**WILLIAM FOSTER**  
Lumber & Commission Merchant  
Receiver and forwarder of  
**LUMBER, LATH & SANGLES**  
Correspondence Solicited.  
**OWEN SOUND, ONT.**

**T. SHORTISS,**  
DEALER IN  
**PINE & MINERAL LANDS**  
9 Toronto Street,  
**TORONTO, ONT.**  
CORRESPONDENCE SOLICITED.

**J. J. TURNER,**  
Sail, Tent and Awning Maker.  
251 GEORGE AND 154 KING STREETS.  
**PETERBOROUGH.**  
Canoe, Yacht and Boat Sails made to order.  
Perfect Fits guaranteed.  
Every description of Lumbermen's Substies and Waterproof Clothing.

**Timber Limits**

BRITISH COLUMBIA.

**FOR SALE!**

\$5,000 to \$50,000 of shares in a Stock Company owning and operating Saw and Planing Mills Sash and Door Factory, etc. Valuable Timber Limits in connection. This is an exceptionally good chance to make money

Address— **LIMITS**  
Care of CANADA LUMBERMAN, Toronto.

**E. F. Ames & Co.**

Lumber Commission Correspondence solicited from Canadian manufacturers.

**Room 3, Lumber Exchange, Chicago, Ill.**

**CHICAGO, MILWAUKEE AND ST. PAUL RAILWAY.**

Electric Lighted and Steam Heated Vestibuled Trains, with Westinghouse Air Signals, between Chicago, St. Paul and Minneapolis, daily.

Electric Lighted and Steam Heated Vestibuled Trains between Chicago, Council Bluffs and Omaha, daily.

Through Vestibuled Sleeping cars, daily, between Chicago, Butte, Tacoma, Seattle, and Portland, Oregon.

Solid Trains between Chicago and principal points in Northern Wisconsin and the Peninsula of Michigan.

Daily Trains between St. Paul, Minneapolis and Kansas City via the Hedrick Route.

Through Sleeping Cars, daily, between St. Louis, St. Paul and Minneapolis.

The finest Dining Cars in the World.

The best Sleeping cars. Electric Reading Lamps in Berths

6,100 miles of road in Illinois, Wisconsin, Northern Michigan, Iowa, Minnesota, Missouri, South Dakota and North Dakota

Everything First-Class

First-Class People patronize First-Class Lines.

Ticket Agents everywhere sell Tickets for the Chicago, Milwaukee and St. Paul Railway

The Gold Medal, Toronto 1883.

Gold Medal, London, 1883.

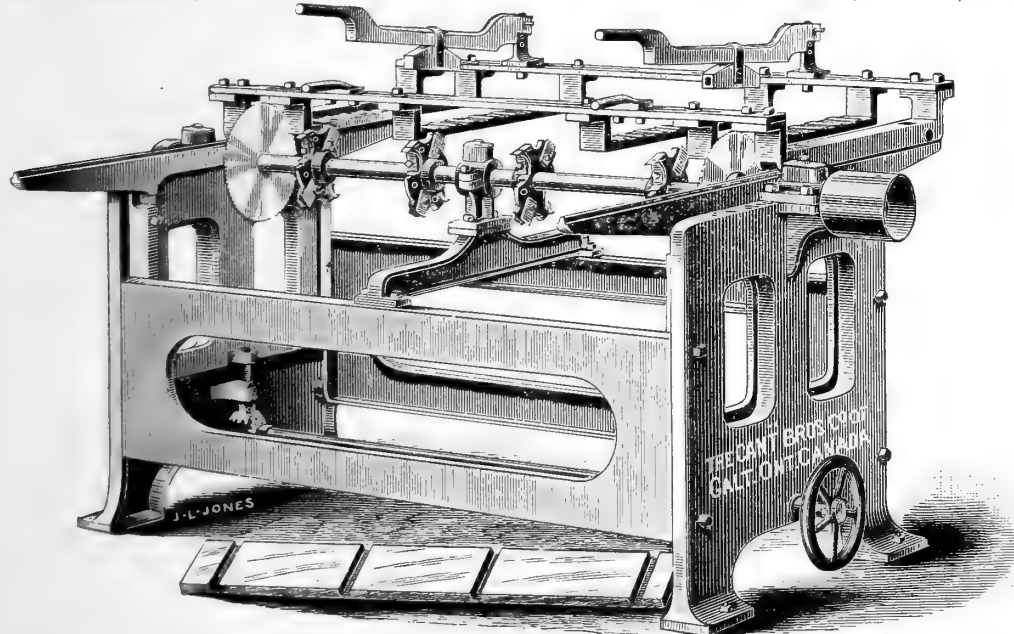

THE MOST PERFECT DOVETAILER IN THE MARKET.

*The Stengel Dovetailer*

Will cut both front and side of the drawer at one time; if narrow two fronts and two sides at one time of any thickness from 1/4 to 1 1/2 inches, and up to 16 inches in width.

**CANT BROS. CO., LTD.**

Wood - Working Machinery for Door, Sash, Blind and Furniture Factories.

**GALT, ONTARIO.**

The Gold Medal,  
Toronto, 1883

# WOOD WORKING MACHINERY

The Gold Medal,  
London, 1883

## For Door, Sash, Blind and Furniture Factories

- |                |                       |                  |
|----------------|-----------------------|------------------|
| PLANERS.       | BAND SAWS.            | BUZZ PLANERS.    |
| MOULDERS.      | BAND RE-SAWS.         | MORTICERS.       |
| TENONERS.      | PANEL RAISERS.        | BLIND MACHINERY. |
| SHAPERS.       | DOVETAILERS.          | BAND SAW FILER.  |
| RIP SAWS.      | JOINTERS.             | BAND SAW SETTER. |
| SAND PAPERERS. | DOUBLE SPINDLE BORER. | ETC., ETC.       |

## The Galt Bros. Co., Limited, GALT, ONTARIO.

Write for Circulars  
and Prices.

Correspondence  
Solicited.

### Rhodes' Improved Swage for Circular and Gang Saws.

PATENTED JULY 2, 1889.

THE MOST PERFECT MACHINE FOR THE PURPOSE EVER INTRODUCED.

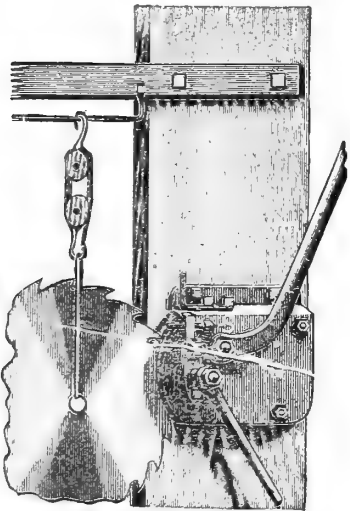

SWAGE IN OPERATION.

It will swage the hardest as well as the softest saws. Never pulls the points of the teeth off, as the swaging is done by direct and steady pressure, and not by rolling pressure.

Swaging done with this machine will stand longer than when swaged with any other machine or by hand. It makes the swage the heaviest on the under side of the tooth, and leaves the face of the tooth perfectly straight. It does not shorten the tooth as done by upsetting. It has a positive clamp so a saw cannot slip while being swaged, therefore every tooth is an exact duplicate of the other.

Corners never drop off if swaged with this machine, as it does not injure the steel, therefore the teeth can all be kept of a length.

It is very simply constructed: nothing to break or wear out. Easily adjusted. Any ordinary man can swage a circular saw in from 10 to 12 minutes. Is thoroughly constructed of the best material, all the parts requiring it are made of steel of the best quality. Every swage is thoroughly tested before leaving the shop.

We positively guarantee the swage to do all we claim for it in this circular.

Full and complete instructions for adjusting and operating accompany the swage.

SEND FOR PRICE LIST OF

RHODES' IMPROVED

Automatic Band Saw Swages, Circular Saw Swages, Gang Saw Swages, Shingle Saw Swages.

—MANUFACTURED EXCLUSIVELY BY—

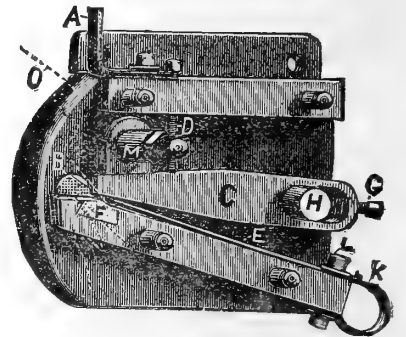

SECTIONAL VIEW.

P. O. BOX 430.

## Palmiter, Empey & Co., Galt, Ont.

Established 1849.

Incorporated 1884.



# Detroit Saw Works

MANUFACTURERS OF

## Circular, Gang, Mulay, Drag and Cross-Cut Saws.

MOLDING AND PLANING KNIVES,

We use nothing but W. J. & Sons' English Steel in our saws and the name speaks for itself.

French Band Saws, Emery Wheels and General Mill Supplies.

66, 68, 70 and 72 Fort St. East, DETROIT, MICH.

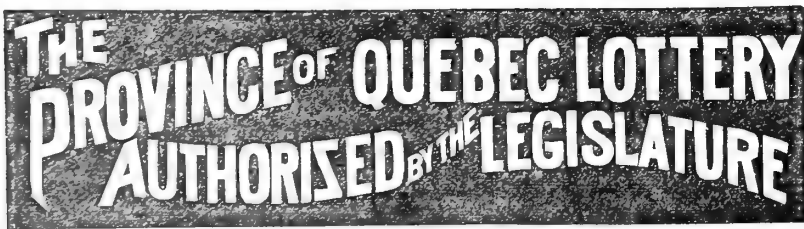

MONTHLY DRAWINGS ON

2nd Wednesday of Every Month

S. E. LEFEBVRE, Manager.

Head Office—81ST. JAMES STREET, - MONTREAL.

PATENTED 5TH MARCH, 1877.

## PARKER & EVANS.

Sole Proprietors of the

### FAMOUS INTERNATIONAL BOILER - FLUID - COMPOUND.

This compound will save its cost many times in one year by saving fuel.

It eradicates scale, and when the Boiler is once Clean a very small quantity keeps it clean and free from all incrustation. One fourth the dose will prevent a new Boiler from scaling so long as it is used regularly.

Contains no Caustic Soda, and is the only matter yet known that will not injure metals in any way, and emits a clear pure steam.

30 WILLIAM STREET, - MONTREAL.



# Friction Pulley Board.

The Best Materials ever used  
for Frictions of all  
\* kinds \*

MANUFACTURED BY

Asbestos  
Mill  
Board.

The **DOMINION LEATHER BOARD COMPANY,**  
Montreal, Quebec.

Steam  
Packing.

SAMPLES FURNISHED.

PLEASE MENTION THIS PAPER.

CORRESPONDENCE SOLICITED

# THE DODGE PATENT WOOD SPLIT PULLEY CO.

MAUFACTURERS OF

Pulleys of every description and style in stock and made to order.

Prices lower than any other first-class Pulley.

**Patent  
Split  
Belt  
Pulleys**

Every pully guaranteed strong enough for heaviest Mill Work, and to give more power with same belt than any other pulley made.

Send for Catalogue and discounts.

## Dodge Wood Split Pulley Co.,

City Office, 83 King St., W.

### TORONTO.

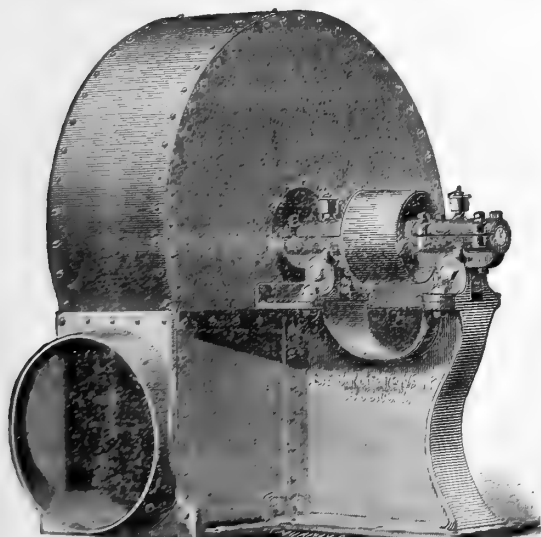

# THE STURTEVANT

STEEL PLATE PLANING MILL

# EXHAUSTERS.

PROGRESSIVE LUMBER DRY KILNS, HEATING AND VENTILATING APPARATUS  
FOR ALL CLASSES OF BUILDINGS.

## B. F. STURTEVANT CO., BOSTON, MASS., U. S. A.

BRANCHES: 91 LIBERTY ST., NEW YORK.  
16 S. CANAL ST., CHICAGO.  
135 N THIRD ST., PHILADELPHIA.

**A. R. WILLIAMS, Soho Machine Works, Toronto, Ont.,**  
GENERAL AGENT FOR THE DOMINION.

# Heavy Mill Machinery

## ENGINES, BOILERS, BURNERS.

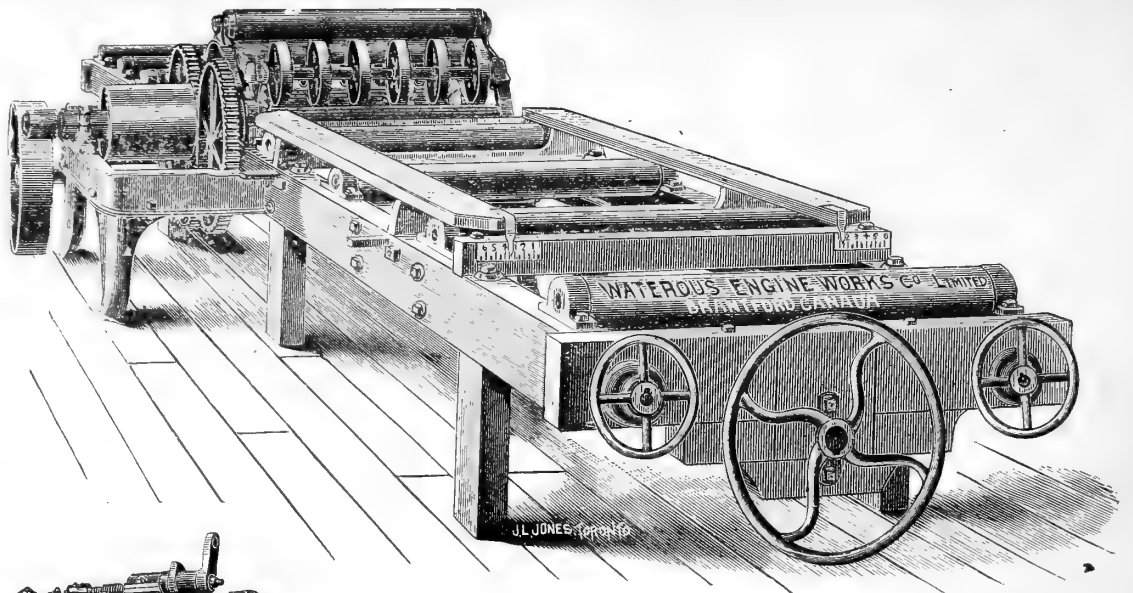

*Our 3 Saw Edger for ordinary Mill Work.*

Special features—Rigid Frame, Powerful Feed. Saws removable from mandrel without disturbing it. Saws readily adjusted. A strong accurate machine. Uses solid or bit tooth saws.

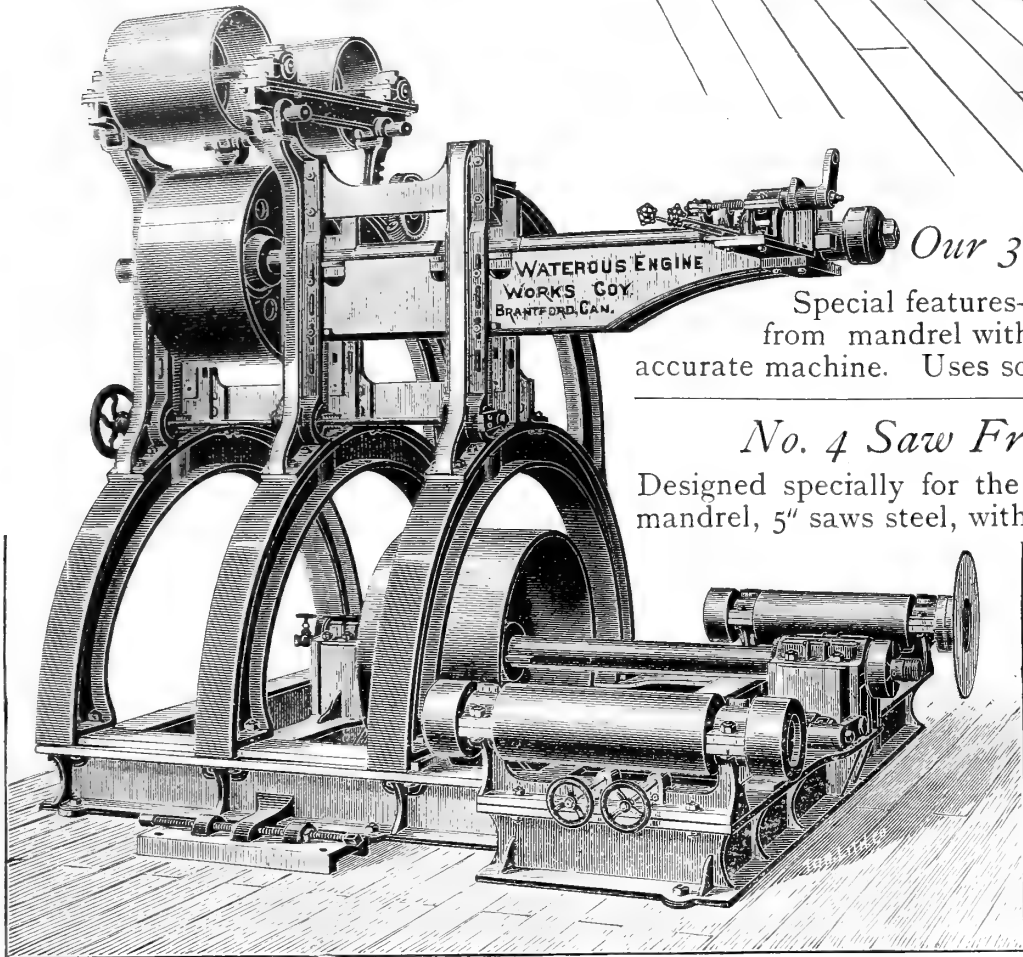

*No. 4 Saw Frame with Top Saw Attachment.*

Designed specially for the heavy work of the Pacific Coast. Hollow lower mandrel, 5" saws steel, with water connection. Adjustable saw guides at top and bottom that turn up to remove saws. Driving pulley on lower mandrel, 36x20" saw, on upper mandrel 30x17" saws, will take in 72" saws.

Oscillating

*Twin Engine*

Steam feed.

Entirely self-contained. All ready to place in mill & attach steam and ex-

haust pipe, wire or manilla rope and starting lever. Several sizes.

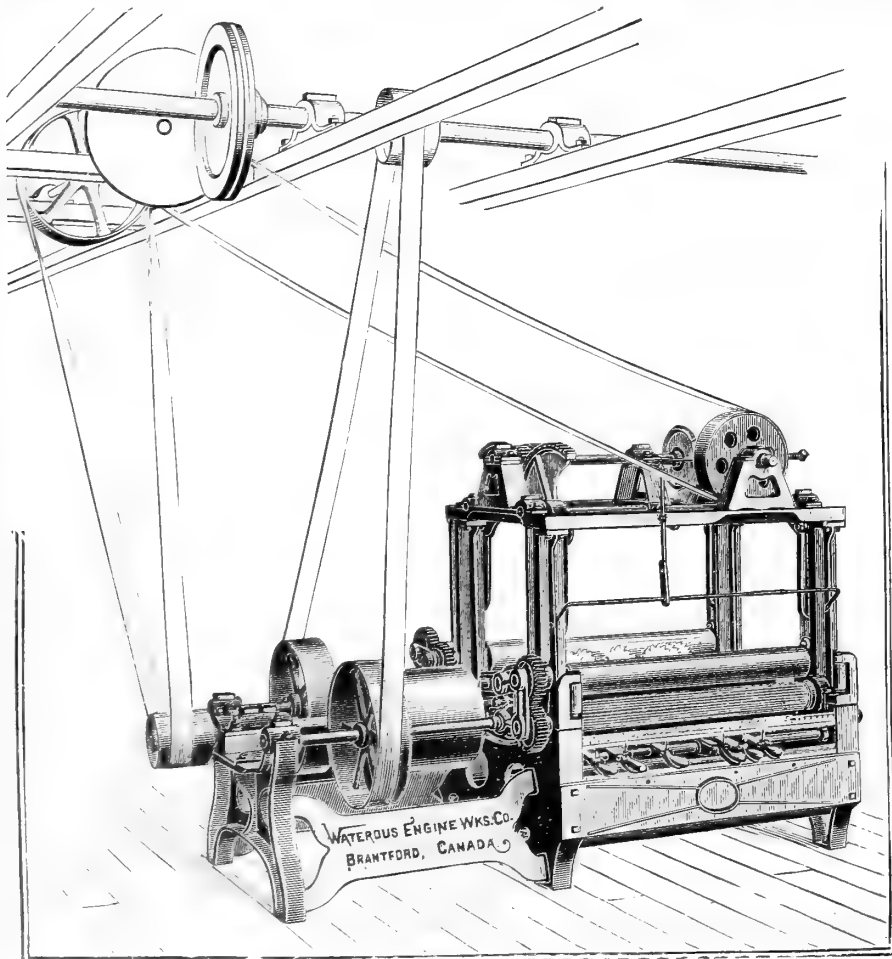
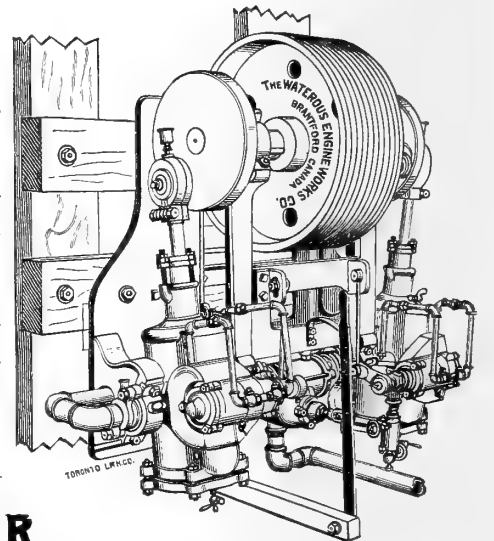

**OUR**

## **Champion Gang Edger**

Mills and logs requiring 4 saw frame need a specially designed saw carriage as our No. 6, (will be illustrated in our next issue) and an extra heavy gang edger such as the Champion that will take on a cant 50 to 60" wide, 8 or 9" thick. Its cast frame is 11 feet x 5 feet, 7 feet high. It is very heavy and very strongly ribbed and braced. Mandrel is 4" steel, running in 3 bearings 12" long, chambered for the circulation of water if necessary.

**DRIVING PULLEY** is 18" diam., 25" saw.

**FEED ROLLERS** are solid wire fluted, cast on steel shafts. The top rollers are lifted by power.

**SAWS** are generally Hoe bit tooth 24 to 26" in dia. held in place by brass safety guide, shifted by hand lever as shown. The feed is an independent variable disk.

*Waterous Engine Works Co.,  
BRANTFORD, CAN.*

# The Only Successful Kiln for Drying Oak and other Hardwoods

**"THE ANDREWS"**

NEW LUMBER

## DRY-KILN

Its remarkable efficiency depends upon its peculiar mode of applying heat to, and eliminating moisture from, the air used in drying. We use no costly fan, engine or other device that requires constant attention, nor do we waste heat by a special chimney. The air circulates through the lumber, and the moisture absorbed from it is extracted from the air by natural methods. You can not afford to be without it.

Our Process Duplicates Nature.

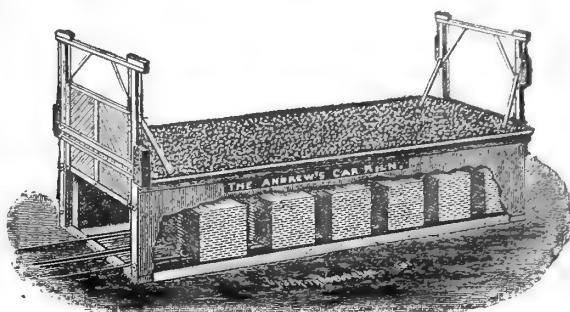

Outside View of the Andrews Kiln.

The following well-known furniture makers have recently purchased the "ANDREWS KILN"

- Estey Manufacturing Co., - - - - - Grand Rapids, Mich.
- East Shore Furniture Co., - - - - - Milwaukee, Wis.
- Universal Tripod Co., - - - - - Grand Rapids, Mich.
- Grand Rapids School Furniture Co., - - - - - Grand Rapids, Mich.
- New England Furniture Co., - - - - - Grand Rapids, Mich.
- Milwaukee Chair Co., - - - - - Milwaukee, Wis.
- Oshkosh Furniture Co., - - - - - Oshkosh, Wis.
- Skandia Furniture Co., - - - - - Rockford, Ill.
- Story & Clark Organ Co., - - - - - Grand Rapids, Mich.
- Rock Falls Manufacturing Co., - - - - - Rock Falls, Ill.
- Courey & Birely Table Co., - - - - - Shelbyville, Ind.
- Southern Spring Bed Co., - - - - - Atlanta, Ga.
- Sidney School Furniture Co., - - - - - Sidney, Ohio
- New Richmond Church Furniture Co., - - - - - N. Richmond, O.

### A. H. Andrews & Co., Proprietors and Manufacturers

215, 217, 219, 221 Wabash Ave., CHICAGO, ILL.

## The Casselman Lumber Co.

CASSELMAN, ONT. Successors to FLATT & BRADLEY.

ESPECIAL GOOD FACILITIES FOR SHIPPING.  
HEMLOCK BILL STUFF OF EXCELLENT QUALITY.  
ALSO MANUFACTURERS OF  
PINE, SPRUCE, ASH, MAPLE AND OTHER HARDWOODS.  
CORRESPONDENCE SOLICITED.

CEO. HASTINGS. JOHN GRAY. H. HANCOCK.

## GEO. HASTINGS & CO.

Lumber Merchants

TRUST BUILDING CHAMBERS,  
Cor. Yonge and Colborne Streets. TORONTO.

All Kinds of Pine and Hardwood Lumber.

BILL STUFF CUT TO ORDER A SPECIALTY.

J. W. MAITLAND  
H. RIXON

J. G. AINSLIE  
W. STODART

## Maitland, Rixon & Co.,

Owen Sound, Ont.

### Saw Millers and Lumber Dealers

All kinds of Building Material kept in stock.

WE MAKE A SPECIALTY OF  
LONG BILL STUFF IN ROCK ELM, PINE, CEDAR AND HEMLOCK  
QUOTATIONS FURNISHED ON APPLICATION.

## DONOGH & OLIVER,

Wholesale Dealers in

# LUMBER

OFFICE:

Nos. 213, 214 and 215, Board of Trade Building,

COR. YONGE AND FRONT STS.

TORONTO, ONT.

## THE "LEADER"

The Finest Tempered, Fastest Cutting  
and Best Saw made on the Continent.

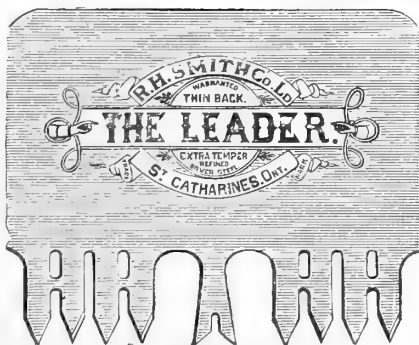

Manufactured of Triple Refined Silver Steel,  
Rolled specially for us from Superior Ingots.

THE KING OF CROSS-CUT SAWS

R. H. SMITH COMPANY, LTD., ST. CATHARINES, ONT.  
Sole Manufacturers.





# PETRIE'S MACHINERY DEPOT.

*Special Bargains  
this month.*

One New Eclipse Planer and Moulder, Galt make.

Champion Planer, Moulder and Moulder, nearly new.

Little Giant Planer, Moulder and Moulder, price \$200.

24-inch Planer and Moulder, Dundas make—New Pony Planers and Moulders, only \$1.75.

24-inch Pony Planer, Frank & Co. make.

27-inch Double Surfacer, revolving bed—Cowan & Co. make.

No. 3 Revolving Bed planer, Cowan & Co. make.

23-inch Pony planer, Foss make, Buffalo.

No. 4 Pony planer, McKechnie & Bertram, builders.

Economist planer, moulder and moulder, Frank & Co. make.

24-inch wood frame planer, Kennedy & Sons make.

Planing machine knife grinder.

24-inch wood frame surface planer, cheap.

24-inch surface planer, Rogers make, Norwich, Conn.

23-inch surface planer, American build.

21-inch wood frame planer, Kennedy & Sons build.

22-inch surface planer, McKechnie & Bertram build.

22-inch wood frame planer, in good order.

20-inch wood frame planer in good order.

12-inch diagonal buzz planer, new, Galt make.

Daniels planer, R. Ball & Co. make.

Moulder, Kennedy & Sons' make, Owen Sound.

Beading and moulding attachment for planer; Ross make, Buffalo.

No. 2 Three-sided moulding machine, Galt make.

3 Sided Moulder, made by Rogers, Connecticut.

New power morticers—Galt make.

One chair or upright boring machine.

Iron top shaper—Goldie & McCulloch make Galt.

Centennial top jig saw—Goldie & McCulloch builders.

Double cope tenoning machine—Dundas make.

New 36-inch resaw—Galt make—also band resaw machines.

Tenoning machine—without copes—price only \$60.

Wood turning lathes—several sizes.

New combination saw table—all iron and steel.

Improved power rod feed machine—MacGregor, Gourlay & Co., Galt, builders.

No. 1 shaper—all iron—Goldie & McCulloch build.

Improved saw arbors—all sizes—Galt make; large stock.

One improved iron frame swing saw—new; Buffalo make.

Sand paperers—new and second hand.

New 20" retailing machine—Tyrell's patent.

New 24" and 26" inch band saws—Galt make.

New 25" inch band saw, Cant Bros. & Co. make, Galt.

Four pair scroll saws and three foot power; good order.

Three blind slot turners, all Galt make.

Dodge wood split pulleys at maker's prices; quick delivery.

Foot and hand mitring machines, latest design.

Foot and hand wiring machine, Galt make.

*Send for our Illustrated Catalogue  
New and Second Hand  
Machinery.*

## H. W. PETRIE

DEALER IN

### New and Second Hand Machinery

OF ALL KINDS.

*141 and 145 Front Street West,  
Toronto, Ont.*

My new and commodious warehouse is fast filling up in every department and new lines are being continually added. Parties requiring Engines, Boilers, Iron or Wood Tools, in fact, anything in the shape of Machinery, will do well to give me a call before placing their orders.

**REMEMBER THE PLACE**

*Immediately adjoining the Union Station.*

H. W. PETRIE PROPRIETOR  
141 TO 145 FRONT ST. WEST  
TORONTO, ONT.

C. C. CLEVELAND. G. F. CLEVELAND.  
**J. L. GOODHUE & CO.,**  
 MANUFACTURERS OF  
**Leather Belting**  
 AND  
**Lace Leather.**  
 DANVILLE - - QUEBEC.

THIS SPACE FOR SALE.

RAILROAD, BANK & OFFICE  
**DESKS**  
 TEES & CO.,  
 300 ST. JAMES STREET, MONTREAL.

**STORAGE OF LUMBER.**  
 We are prepared to receive any quantity of Lumber for storage. Freight and money will be advanced on same. Also, Warehouse Receipts issued, which can be hypothecated to banks and others. Storage charges easy. For further particulars apply to  
**W. LEAK & CO.**  
 Lumber, Coal and Wood.  
 DUNDAS STREET, - - TORONTO.

**GOODDAY, BENSON & CO.**  
 QUEBEC, P. Q.  
**General Lumber & Timber Merchants.**  
 Correspondence is solicited from parties having choice stocks of Hardwood and Pine to offer, either in the log or in sawn lumber.

**JOHN BERTRAM & SONS,**  
 CANADA • TOOL • WORKS  
 DUNDAS, ONTARIO.  
 MANUFACTURERS OF  
**WOOD-WORKING MACHINERY**  
 MACHINE TOOLS, ETC.  
 Write for Prices and Catalogues

**Packing Cases in Shooks.**  
 Any Saw mill in Canada able to undertake large orders for Case Boards is requested to communicate with  
**W. & C. PANTIN**  
 147 Upper Thames Street,  
 LONDON, - - - - - ENC.

**GEO. CORMACK**  
 Wholesale and Retail Dealer in  
*All kinds of LUMBER.*  
 Lumber Shipped to all parts by Rail or Vessel.  
 WHITBY, - - - - - ONTARIO

**TORONTO**  
**Lithographing Co.**  
**LITHOGRAPHERS &**  
**TORONTO ENGRAVERS.**

THOS. WHALEY, President. W. E. HUTCHINSON, Sec.-Treas.  
**The Whaley Lumber Co.**  
 OF HUNTSVILLE, ONT. (LIMITED)  
 Manufacturers of  
**White Pine Lumber, Bill Stuff, Lath and Shingles**  
 ALSO HARDWOOD LUMBER.  
 All orders promptly attended to. First-class facilities for shipping.  
 CORRESPONDENCE SOLICITED.

**THE RATHBUN COMPANY,**  
 DESERONTO, - - ONTARIO,  
 MANUFACTURERS OF  
**Doors, Sash, Blinds, Stairs**  
 AND ALL KINDS OF WOODEN HOUSE FINISHING MATERIALS.  
 CEDAR OIL FOR PURGING BOILERS.  
 CORRESPONDENCE SOLICITED

**The American Lumber Yard**  
**HAMBURG, GERMANY,**  
 Offers the best facilities for Yarding and Selling all kinds of  
**American Wood Goods.**  
 Address :  
 ROSENBACHER & CO., BANKERS, Hamburg. CARL GARTNER, Agent, Hamburg.

**ROBIN & SADLER**  
 MANUFACTURERS OF  
**Leather Belting**

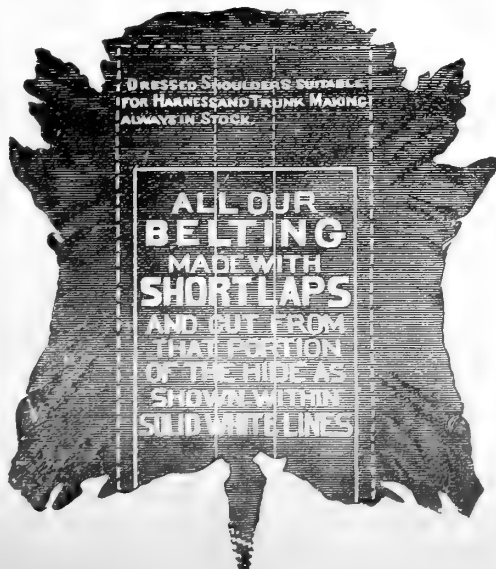

DEALERS IN  
**Lace Leather**  
 Cotton and  
**Gandy Belting**  
 2518, 2520 and 2522 Notre Dame St. MONTREAL.  
 129 Bay Street, TORONTO,

TAPER TOOTH.

E. R. Burns Saw Co.

MANUFACTURERS OF

LANCE TOOTH.



TELEPHONE 5120.

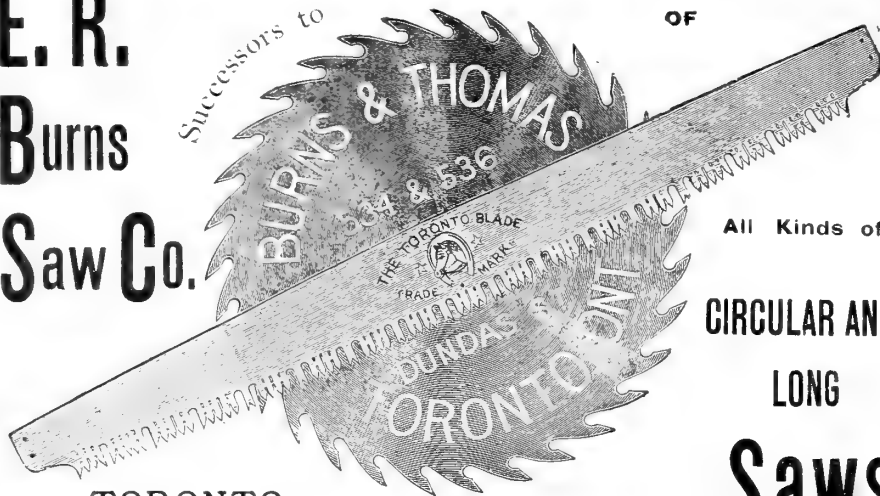

TORONTO.

All Kinds of CIRCULAR AND LONG Saws



WORKS AT PARKDALE.

TO MILL OWNERS, MANUFACTURERS

AND ALL WHO ARE USING

Leather \* Belting

IF YOU WANT BELTING

Which will Run Straight on the Pulleys, Which is Thoroughly Well Stretched, Which will not Tear at the Lace Holes, Which will give Complete Satisfaction,

— SEND TO —

F. E. DIXON & Co.

MANUFACTURERS OF

PATENT LAP-JOINT STAR RIVET \* LEATHER \* BELTING \*

70 King Street East, Toronto.

Sole Agents in Canada for the

CELEBRATED PHOENIX OIL

The Only Perfect Belt Dressing.

All our Belting is sold at the Canadian price list. Please compare before purchasing. Send for Discounts and our Pamphlet on Belting.

TORONTO AGENCY OF

The Rathbun Co.

ARE OPEN TO PURCHASE

OAK, ASH, BIRCH, BASSWOOD

AND

GOOD PINE LUMBER

CEDAR AND PINE SHINGLES

Manufacturers having such for sale, are invited to communicate with

T. W. WALKER, Agent

TORONTO.

Office, Cor., Spadina Ave. & Front St.



SCRIBNER'S LUMBER AND LOG BOOK

Over One Million Sold.

MOST complete book of its kind ever published. Gives measurement of all kinds of Lumber, Logs, Planks, Scantling; cubical contents of square and round Timber; hints to lumber dealers; wood measure; speed of circular saws; care of saws; cord-wood tables; felling trees; growth of trees; land measure; wages, rent, board, interest, stave and heading bolts, etc. Standard book throughout the United States and Canada. Get the new illustrated edition of 1892. Ask your book-seller for it. Send post-paid for 35 cents.

GEO. W. FISHER,

Box 238, Rochester, N. Y.

or A. G. MORTIMER,

Toronto, Ontario.

WICKES BROS., Saginaw, Mich.

MANUFACTURERS OF

GANGS, ENGINES AND BOILERS.

The accompanying cut represents our new No. 3 Complete Iron Frame Gang Mill especially designed to meet the demand for a smaller type of mill. The strongest and most durable for high speed and thin saws. Write for further particulars,

Southern Agents, McARDLE & SINCLAIR, 50 & 52 Barronne St New Orleans, La.

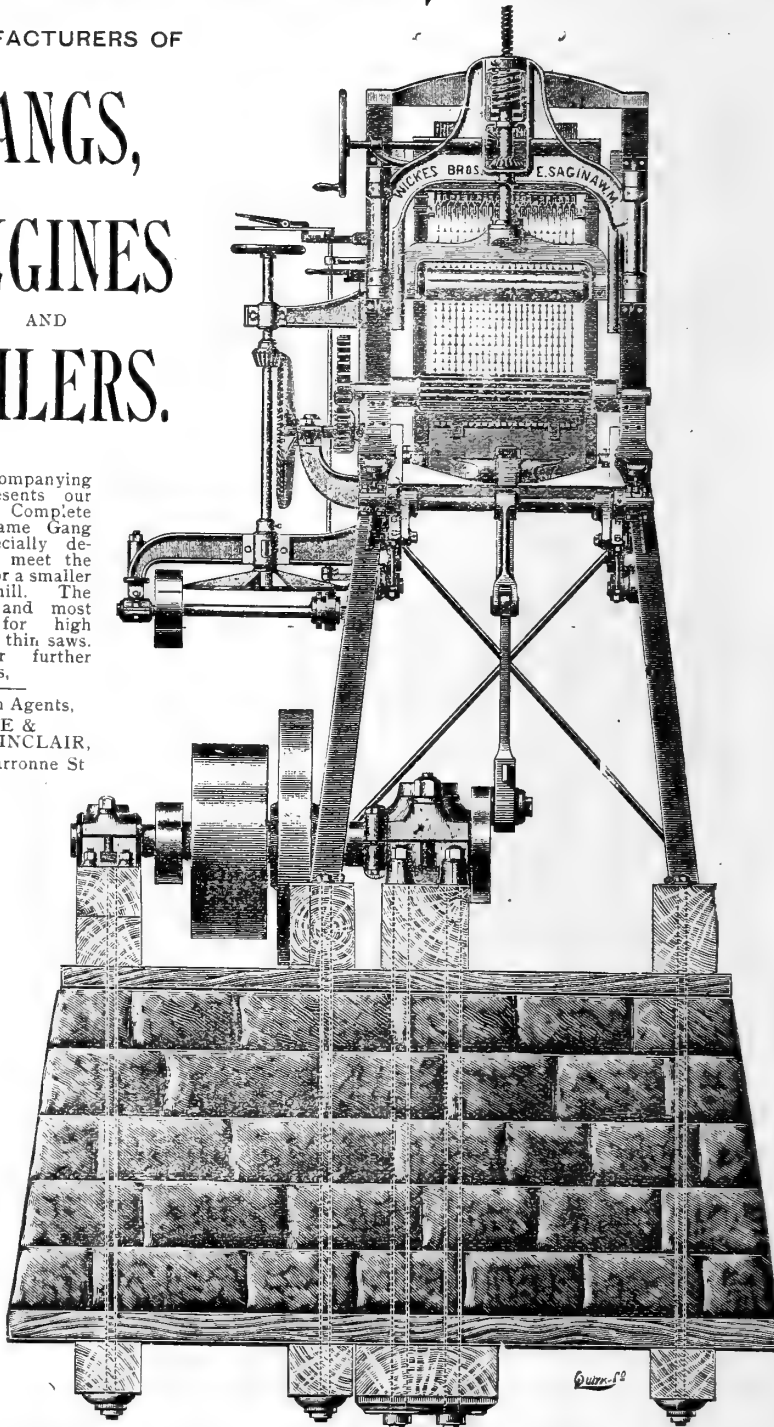

Fawcett & Co. MERCHANT \* TAILORS, 269 Queen St. E., Opp. Seaton St., Toronto.

First-Class Goods and Trimmings. Workmanship and Fit Guaranteed. All Orders Punctually Executed.



# THE CANADA LUMBERMAN.

VOLUME XII }  
NUMBER 7 }

TORONTO, ONT., JULY, 1891.

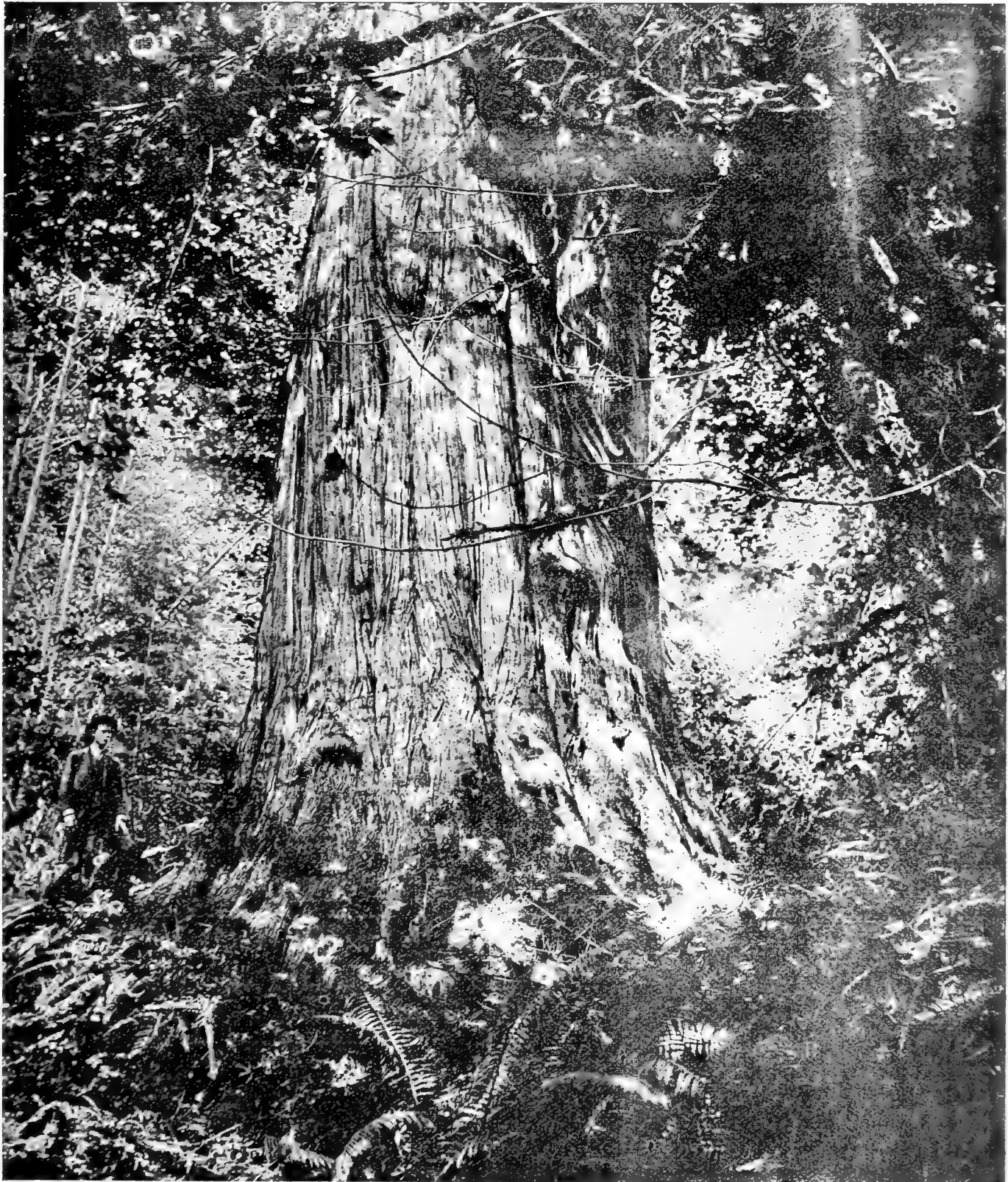

12125

TREE IN STANLEY PARK, VANCOUVER, B. C.

## LOSS FROM CARELESS HANDLING AND PILING OF LUMBER.

BY H. B. WETZELL.

PERHAPS there is no leakage in the profits of the manufacturer or consumer of lumber so little noticed, as that which results from the careless piling and handling of lumber. This leakage is a silent and insidious enemy. Unless one be constantly on the guard, it finds its way into various places about the mill and yard where it can do damage. Only the most vigilant eye, the most watchful care, will keep it away. Most of its effective work is about the premises of the man of careless habits. The methodical, systematic and thorough business man will not harbor this enemy on his premises.

There are some men who seem to be naturally neat, precise, careful and methodical in their business affairs and daily life. Others are the opposite. The freedom of outdoor life and the nature of the business of the lumberman, tends to break down and keep away rigid rules and observances such as characterize other kinds of business. The average lumberman is free, open-hearted, and does not cultivate nor realize the value of small things. Herein lies the danger of waste in his business—the enemy that is insidiously sipping away at his profits.

When one goes into a lumber yard and sees every pile of lumber put up as if following out geometrical rules, one may be safe in assuming that the owner is in a prosperous condition, or travelling in the right road to reach it. He has certain rules which must be observed, and which usually show that the details have been looked into. There may possibly be such a thing as being too exacting, too precise, spending too much time for appearance sake, but as a rule it doesn't take any longer to pile lumber well than to pile it badly.

On the other hand if one will go into a lumber yard about a saw mill, planing mill, wholesale or retail yard, or any establishment where lumber is worked up, and sees lumber lying carelessly around, a board or plank here and there out of place, some split, others warped and twisted, others badly weather-stained, it is sufficient evidence that the owner is careless and is not making as much money as he should.

Wide lumber, especially thin stuff, requires careful handling to avoid splitting. Take an inch board 12 ft. long, 18 inches wide; it contains 18 ft. of lumber, board measure. If it be of a grade worth \$30 per thousand, the piece is worth 54 cents. By careless handling it may be split, either at one or both ends. That will reduce its grade and shipping value at least \$10 per thousand, or one-third its value. Here is a loss of 18 cents on that one piece. If a piece be split off diagonally on one end or side, causing a loss of say three feet or one-sixth, the grade will be reduced at least one-half in value. Then there would be but 15 ft. to sell, or use, and it would bring 22½ cents, or a loss of 63 per cent. Now if this kind of work stopped at this one piece, the loss would not be great, but the probabilities are that there will be many such pieces during the course of one day only, more than enough lost to have paid the wages of several workmen who handled the lumber.

In going into a lumber yard, nothing looks more unattractive than to see a board here, a plank there, out of place, thrown about like piles of rubbish, wagons or carts, or cars running over them; some split, others warped and twisted, some damaged from sun, rain, or other causes; in fact a loss of several per cent. of leakage, which might have been a profit in the business if properly managed.

## LUMBERING IN BRITISH COLUMBIA.

AN OTTAWA gentleman who has been inspecting the lumber resources of British Columbia writes to a friend in Ontario as follows, regarding the products of the forest of his adopted home: "Fir is the staple wood of the country, next comes cedar, then spruce, alder, soft maple, cotton, yew, etc. Our market for fir is China, Japan, east and west coast of South America, India, South Africa, but principally Australia, and a few cargoes to the Sandwich Islands. The latter country has a treaty with the United States which admits American woods free, while others have a duty.

We have not yet sawn any for export, but expect to saw a few cargoes during the summer. So far the local and northwest markets have kept us going, but we will have to look for a foreign outlet for part of our production owing to the increased capacity of our new mill. Last season we cut with the old mill 3,000,000 feet and 6,000,000 with the new. I think we will cut about 20,000,000 this season. The mills here usually cut about eleven months in the year. We have a sash and door factory in connection with our mill and will likely make 100,000 salmon cases this season. Milling is quite different here from Ottawa. There the average of the logs is 100 feet, while here it is 1,200 feet, and I assure you, it requires strong machinery to break up these big logs. The largest log we have cut since I came here was 72 inches in diameter, and the longest 85 feet. The largest log that ever came to our mill was 54 inches in diameter and 115 feet long, this was perfectly straight and without a knot or blemish for 100 feet up, in fact there was only one green limb on the log, and strange as it may seem, was put into the water by two men. The largest logs are put in by hand loggers, two of whom make a camp. They cut trees where the ground slants to the water and by barking them and raising them with jack screws, get them started and they roll into the water, nothing will stop them when once they start. The quantity and size of cedar is surprising, and all sash and doors are made from that wood. The doors are all free from knots and blemishes. Our shingles which are cedar are the same. We make only first quality, and they are first quality running up to 14 inches wide, or as large as the machine will cut. Labor is high. Ordinary labor is \$1.50 to \$2.00 per day, and skilled \$2.50 to \$3.50, and we pay our head sawyer \$4.00, the man that runs our gang \$3.50, our edger man \$2.50, filers get \$3.00 to \$4.00 and ten hours is a day. The fishing on the river, or rather salmon canning, is a large industry, and the Indians who do most of the fishing spend all their money here. About all the farming land on the coast is on the Fraser, the quantity is limited, and good lands bring \$50,000 to \$200,000 per acre, according to quality and location, \$100,000 being paid for farming lands partly improved. Four tons of hay and 100 bushels of oats per acre is not considered a remarkable crop here, it is the producing qualities of the land that give it value as well as the scarcity on the lower Fraser. There is good land at Kamloops, Shuswap, the Okanogen Valley, etc., etc., but those places are only accessible by railway, and of course the railway gets most of the profits. The bunch grass of British Columbia is said to produce the sweetest beef in the world. It is usually about the same price as in Ottawa, and of excellent quality. Our flour mostly comes from the northwest and Manitoba. Every person in this country has money, and is not afraid to spend it. We have no beggars and no poor. Our store did a business of \$35,000 last year, and our mill, shingle mill and factory about \$165,000, and \$100 covered our losses by bad and doubtful debts."

## COLLINS AND THE BEAR.

PATRICK COLLINS is the foreman of a wood-cutting camp on the Scott Road, B. C., and though he has had some experience in the management and culture of domestic animals, never until a few days since did he feel competent to shoulder the responsibility of running a menagerie and keeping the wild beasts in hand simply by the use of soft and persuasive language. He had strolled into the bush by himself to meditate and pick out a nice clump of timber for the woodman's axe. A huge fallen tree obstructed his path, and, as he climbed up at one end of it, a gigantic bear, weighing at least 1,000 lbs., made its appearance at the other. Both came to an upright position at the same time: Collins stood perfectly still, and the bear advanced three paces and stopped. The man and the bear eyed each other rather suspiciously for a few moments; what bruin's thoughts were will never be learned, but Collins says he had never been so terribly affected since the last illness of his mother-in-law, when it was very doubtful whether she would pull through. Coming to the conclusion that something must be done, Collins made up his mind to trust to a little Irish blarney, and

the following chaff is reported by Mr. Collins himself: "Shure now, its a foine log we're on, an' there's enough for ourselves and sveral more. Its pleasant walking in the woods on Sunday, especially whin we mate in this agreeable way; quite friendly isn't it?" The bear gave a grunt and moved forward a pace as if to embrace Pat and prove his friendship, at least. "Hould on now, hould on," said Collins, "much as I admire ye, its better to kape our distance till we've come to an understanding. Sure you're a foine agreeable looking cray-thure, and if you'll say 'peace,' begob I'll ratify the bargain and lave you alone, but if you say 'war,' why I'll climb a spalpeen of a tree and shout till Bill comes wid his gun and kills ye. D'ye moind that now, ye divil?" The bear took a look to the right and left as if expecting the formidable Bill and his gun to break in on the conversation at any moment; and sure enough William's melodious voice was heard, about half a mile away, chanting a ditty about "The woodchuck climbed the big hemlock tree." "Now thin, listen to that will ye," said Collins, "and whisper, acushla, lave the log instantly, for if Bill gets sight of ye, ye're hide wouldn't hould enough fur to kape ye're skin from the musquetes." Whether it was this dire prediction, or the remembrance of business matters elsewhere, can only be conjectured, but in an instant bruin turned, shot off the log and sailed away through the bush as if a hundred fiends were after him. Collins also turned and made as rapid progress in the opposite direction, nor did he stop until he was safe under the protection of William's deadshot gun.

## TO SAW TOUGH TIMBER.

ALL tough timber, when the logs are being sawed into lumber of any kind, whether scantling, boards or planks, will spring badly when a log is sawed in the usual manner, by commencing on one side and working toward the other. In order to avoid this it is only necessary to saw off a slab or plank alternately, from each side, finishing in the middle of the log. We will suppose, for example, that a log of tough timber is to be sawed into scantling of uniform size. Let the sawing be done by working from one side of the log to the other, and the end of the scantling will be of the desired size, while at the middle some of them will measure one inch broader than at the ends. After the log has been spotted, saw off a slab from one side; then move the log over and cut a similar slab from the opposite side. Let calculations be made before the second is cut off, so that there will be just so many cuts—no more, no less, allowing for the kerf of every cut. If the log is to be cut into three-inch scantling, for example, saw a three-inch plank from each side until there is a piece six and a quarter inches thick left in the middle. The kerf of the saw will remove about one-fourth of an inch. When a timber-log is sawed in this way, the cuts will be of uniform thickness from end to end. Now turn the log down, and saw the cuts the other way in the same manner, and the scantling will not only be straight, but of a uniform size from one end to the other, if the saw be started correctly.

## A RAILROAD ON TREE TOPS.

IT may not be known outside of the neighborhood in which it is situated, but it is nevertheless a fact that in Sonoma county, Cal., there exists an original and successful piece of railroad engineering and building that is not to be found in the books. In the upper part of the county named, near the coast, may be seen an actual railroad bed on the tree tops. Between the Clipper Mills and Stuart Point, where the road crosses a deep ravine, the trees are sawed off on a level with the surrounding hills, and the timbers and ties laid on the stumps. In the centre of the ravine mentioned two huge red wood trees, standing side by side form a substantial support. These giants have been lopped off seventy-five feet above the bed of the creek. This natural bridge is considered one of the wonders of the Golden State and for safety and security far exceeds a bridge framed in the most scientific manner.

It is somewhat singular that lumbermen and loggers never talk about forests. Plain woods is enough for them.

## SIR JOHN A. MACDONALD.

THE dead chieftain! So much has been written and said of Sir John A. Macdonald, since he was stricken with paralysis on 29th of May, resulting in death on Saturday, 6th June, that it seems almost a work of supererogation to add another line. And yet, where is the individual or institution, that does not desire, though it may be in the humblest fashion and fewest words, to pay a last tribute to the dead Premier?

Politics are nowhere at the grave of one, who labored for his country's welfare, through a long life time, as did the deceased statesman. Friend and foe are ready, to extend to him, that well earned praise and commendation, that has been his by—deeds.

John Alexander Macdonald was the second son of Hugh Macdonald, a Highland Scotsman, a native of Sutherlandshire and his wife Helen Shaw, of Badenock, Invernesshire, who removed to Glasgow in early life, where their son, the future Canadian Prime Minister, was born, on 11th Jan., 1815.

In 1820 the father removed to Canada and settled at Kingston, Ontario. In four years he left Kingston for Adolphustown, on the Bay of Quinte, where he leased a saw and grist mill a short distance from the settlement. The son John remained in Kingston attending the Grammar school. In 1836 the father returned to Kingston and engaged in business. When sixteen years of age John left school and entered the law office of Mr. George Mackenzie, and at 21 he was admitted to the bar and commenced the practice of law in Kingston.

In his young days he took a lively interest in politics, and at the general election of 1844 he offered himself as candidate for Kingston in the Conservative interests. The Limestone City was at that time the seat of government. He was elected over his opponent by a large majority, and continued to represent that place for 34 years afterwards and then, after an interval of eight years, for five years more.

We shall make no attempt to trace the career of this foremost parliamentarian through these many years—extending almost to half a century. With them is written the history of Canada, and the general facts are known to Canadians—young and old. He scored many wonderful successes, he had his reverses. He died, as he had desired, practically in harness and as head of the government whose destinies he had controlled and shaped during a period of years granted to few men.

Of his strong social nature every one knows—an element that stood him in great stead in many a tight corner. In his domestic relations he was singularly happy, and time will never tell how much of his political success and to what extent his years of life and powers of mental and physical endurance were due to the affectionate care and devotion of Lady Macdonald. He died in his 76th year, and was buried in his native city Kingston.

## COMING CHANGES.

NOT the earth but a good sized piece, is asked for by the new Massey-Harris Co., (L'd.), whose application for letters patent of incorporation are published in a late number of the *Canada Gazette*. Hitherto these concerns have confined their efforts principally to the manufacture of agricultural implements of various kinds, and on probably a more extensive scale than by any other company in the Dominion. The new combination does not intend to confine its energies to any pent-up Utica. They ask leave to do all they have been doing and in addition to have powers to manufacture waggons, vehicles, household furniture, stoves and hardware goods; to deal in iron, steel, nickel, rope, cordage, kine, oakum, etc.; to carry on a printing, publishing and advertising business and to act as general traders, with power to amalgamate or absorb other enterprises.

The request ends here, so far as details are concerned, though the application in some particulars, for example, "to act as general traders," is broad enough to admit of almost any class of mercantile transactions. In last month's MILLER we expressed ourselves somewhat fully on the question of combines. We had not before us at that writing the particulars given above. These emphasize, in still stronger terms, the thought there expressed, that the whole tendency of modern trading is towards a consolidation of kindred interests in one greater interest. But the movement goes beyond this. It is suggestive of the question: should a manufacturer be a manufacturer only? Or why should a dry goods merchant sell silks and cottons and kindred goods and stop there? Why not extend the list to foot-wear, groceries fancy goods, and if you like, butcher's meat?

Everyone is aware that trading to-day is taking this shape. We have dry good stores in this city that sell almost everything else that comes under the head of store keeping. The bazaar store, which is the general term for these places of trading, is a factor in all our



THE LATE RT. HON. SIR JOHN A. MACDONALD.

cities, and their influence is seriously felt by the business men in the outside communities. The cheap fares that are ever and anon offered by our railway companies, combined with the perfectness of our postal and express systems, practically bring the trading advantages of the larger town to the shopper, even in the remote sections of the country.

Now we have a great manufacturing concern going into store-keeping, at least asking the privilege to do so, and the: concluding prayer of the petition that they shall have power "to amalgamate and absorb other enterprises" is most suggestive. Are we approaching the age of Bellamy or are we getting away from it? We are undoubtedly on the eve of important changes, both in the commercial and social world. The closing days of the nineteenth century are freighted with many wonderful thoughts and movements bearing in this direction.

This article is simply suggestive. What thought have you on the question dear reader? We shall be glad to hear from you.—*Canadian Miller*.

## USEFUL INFORMATION

There is a natural law relating to belting which is not generally known, but which is nevertheless of value in practice. The hug or adhesion of a belt is as the square of the number of degrees which it covers on the pulley. For example, a belt that covers two-thirds of the circumference of a pulley requires four times the power to make it slip as it does when it covers only one-third of the same pulley.

Take one ounce of camphor, dissolve it in one pound of metal lard: remove the scum and mix as much fine black lead as will give it iron color. Clean the machinery and smear it with this mixture. After twenty-four hours, rub clean with soft linen cloth. It is stated that this mixture will keep machinery clean for months under ordinary circumstances.

The soaps used for cleaning metal work usually consist of mixtures of vasoline, oleic acid and fat, mixed with a small quantity of rouge. When freshly prepared they leave nothing to be desired; but, unfortunately, such mixtures soon turn rancid, and become unfit for use. A new soap for metal work, which is stated to be free from this objection, is made from coconut butter in the following way: 2.5 kilograms of the butter are melted in an iron vessel, together with a little water, and to the mixture is added, with constant stirring, 180 grammes of chalk, 87.5 grammes of alum, 87.5 grammes of cream of tartar, and 87.5 grammes of white lead. This mixture is then poured into moulds and allowed to solidify. The soap so obtained is made into a paste with water and rubbed over the metal to be cleaned, and finally removed by a dry rag or chamois leather.

Sawdust seems coming to the front most wonderfully in various ways. A French writer recommends the use of sawdust in place of the hair usually mixed in mortar. He made a composition of two parts sawdust, two parts lime, five of sand and one of cement, which he alleges is very firm and will not peel off. The Technical Royal School at Charlottenburg has been making a series of experiments with sawdust, and has now proved that it can be used as building material. The sawdust is mixed with certain refuse mineral products, and compressed with a pressure of 1,500,000 kilogs to the quadrameter into the form of bricks. After this treatment, the sawdust forms excellent building material, very light, impervious to wet and utterly uninflam- mable. A slab of this substance was placed for five hours in a coal fire and came out of the test intact.

Oak timber loses about one-fifth of its weight in ordinary seasoning, and, about one-third of its weight in becoming perfectly dry.

It is found that by placing layers of hair felt under the foundations of steam engines and dynamos, noise and vibrations are materially deadened.

The use of rope transmission, says an exchange, is becoming more common every day and will continue so, but at such a continually increased rate that it is advisable for all engineers to become as thoroughly familiar with the use and care of ropes as they are now with belts. When a belt breaks or requires taking up, the job is usually performed by a simple process of lacing or connecting with some kind of belt hook made especially for the purpose; but where ropes are used, there is no patent fastener yet on the market by which the job of connecting them can be simplified. The task of splicing a rope is not more difficult than that of lacing a belt.

The old story "for want of the nail the shoe was lost, for want of the shoe the horse was lost," is paralleled in the case of the oil cup, says Robert Grimshaw. A poor cup can do much to ruin an engine or machine; a good one, much towards bringing it up to the highest standard of duty. In this matter do not try experiments rashly. You may try one cup against another, in some place where heating will not do serious damage; but don't fit out all the way through with any untied cup, no matter what is promised for it. If the new cup is better than the old one, it may pay you to take off the old ones and put on new ones. If it is not better, there will be no advantage to you to try the new ones. It never pays to take a risk, however slight, unless you are paid to take it.





PUBLISHED ON THE FIRST EACH MONTH BY

ARTHUR G. MORTIMER.

OFFICE:

75 CANADA LIFE ASSURANCE BUILDING,  
TORONTO, ONTARIO.

TERMS OF SUBSCRIPTION:

One Copy one Year, in Advance, - - - - - \$1.00  
One Copy six months, in Advance, - - - - - 50  
Foreign Subscriptions \$1.25 a Year.

Advertising Rates Furnished on Application.

THE CANADA LUMBERMAN is published in the interests of the lumber trade and of allied industries throughout the Dominion, being the only representative in Canada of this foremost branch of commerce of this country. It aims at giving full and timely information on all subjects touching these interests, discussing these topics editorially and inviting free discussion by others.

Especial pains are taken to secure the latest and most trustworthy market quotations from various points throughout the world, so as to afford to the trade in Canada information upon which it can rely in its operations.

Special correspondents in localities of importance present an accurate report not only of prices and the condition of the market, but also of other matters specially interesting to our readers. But correspondence is not only welcome, but is invited from all who have any information to communicate or subjects to discuss relating to the trade or in any way effecting it. Even when we may not be able to agree with the writers, we will give them a fair opportunity for free discussion as the best means of eliciting the truth. Any items of interest are particularly requested, for even if not of great importance individually, they contribute to a fund of information from which general results are obtained.

Advertisers will receive careful attention and liberal treatment. We need not point out that for many the CANADA LUMBERMAN, with its special class of readers, is not only an exceptionally good medium for securing publicity but is indispensable for those who would bring themselves before the notice of that class. Special attention is directed to "WANTED" and "FOR SALE" advertisements, which will be inserted in a conspicuous position at the uniform price of 15 cents per line for each insertion. Announcements of this character will be subject to a discount of 25 per cent, if ordered for three successive issues or longer.

Subscribers will find the small amount they pay for the CANADA LUMBERMAN quite insignificant as compared with its value to them. There is not an individual in the trade or specially interested in it, who should not be on our list, thus obtaining the present benefit and aiding and encouraging us to render it even more complete.

#### TRADE—RETROSPECTIVE AND PROSPECTIVE.

THE general managers of the Bank of Montreal, the Merchants Bank of Canada, and the Canadian Bank of Commerce, the three largest monetary institutions in the country, have each given to the public, the usually carefully considered address, that accompanies the annual financial statement of their respective institutions. No more able resume of the commercial conditions of the entire Dominion, and, to some extent, a forecast of the future, can be found than that furnished in the annual utterances of these gentlemen.

It is perhaps not always wise for business men to accept the *ipse dixit* of any one person, as a safe guide for the conduct of their individual business, but the opportunities, of the heads of these large monetary concerns, to gauge the conditions of business at all points, both in our own Dominion and neighboring countries and across the sea, and from this data to prepare a careful diagnosis of the entire situation, is so exceptional, that we may take their utterances as exceptional too, and carefully con and study them.

The address of the chief officer of the Bank of Montreal was taken up largely in answering the criticism of shareholders, caused by the reduction of profits, during the last half year, to 1½ per cent., where 5½ per cent. had been the usual average for a six months' period. His reply, we believe, was satisfactory to those directly interested, while the report of affairs generally showed the bank to be in a thoroughly healthy condition. It was a case of a new manager, who felt it to be his duty and the wise course for the Bank, at the outset of entering office, to sharply scrutinize all assets and make provision for possible losses, that had hitherto

been counted as more substantial properties. We want no better evidence, however, of the sensitive nature of commerce, than the flutter of excitement that was created, when the bank statement was first issued, and before the manager's explanations had been made. A strong pronouncement is made for the enactment of legislation by which insolvent estates can be more equitably divided than is the case at present. It is worthy of note that the Merchants' manager presses the same matter upon the commercial public.

The general manager of the Commerce referred with pleasure to the increase in deposits, which in his bank had now reached the handsome figure of fifteen millions, and which showed a permanent gain during the last five years of about five million dollars. The failure of the Barings is made the subject of comment both by Mr. Walker and Mr. Hague, the former quoting the remark of a witty statesman, who classed this banking firm some years back, along with the five leading nations, as the sixth great power of the world. Mr. Hague makes the occasion one for reading the mercantile world, and bankers as well, a common sense lesson on the evils of over-trading. Men go into business without any capital and the outcome is purely speculative with the odds terribly against them; retailers strike out as wholesalers, with insufficient capital, and too often the end is only disaster; and wholesalers, with a moderate capital, become ambitious to extend their borders, and get beyond their depth. A house worth even a million, may over trade as well as any other, and "this affair of the Barings," says Mr. Hague, "is a terrible lesson in this direction."

The special reference by the Commerce and Merchants managers to the lumber industries, we print in full in another column. The former points out that "there is still in sight more timber than the total product of any year since 1881, although the amount made in the past year is only about one-fifth of that for 1889-90," and his argument is that the business can only be brought up to a healthy condition by manufacturing very little for another year. And the Merchants manager expresses the same thought in the sentence: "The lumber trade is gradually recovering itself through a heavy decrease in productions."

Deposits in the Merchants have increased considerably. The total earnings, while equal to the average of recent years, have been affected in a measure through the necessity of taking from them a larger amount than usual to provide against losses and depreciations.

Mr. Hague does not consider that his bank has been sufficiently remunerated for much of the business that has been done, and attributes this to the severe competition which has shown itself in banking, as well as in other branches of trade. "Many mercantile failures in this country," he says, have arisen from borrowing too freely," adding the sage remark, "I have never known any one to fail in Canada because he borrowed too little."

The present condition of business in the Dominion is pronounced prosperous in some relations and the reverse in others. In British Columbia and the Maritime Provinces business is reported to be in a flourishing condition, but this much cannot be said of Ontario or Quebec. The practice in Canada of both retailers and wholesalers giving long credits, is deprecated in vigorous language and sensible logic.

Time alone will reveal the real effects of the McKinley tariff. No pessimistic view is taken of the situation, for we are cheerily told that if one market closes another will be opened.

What of the future? These bank managers wisely refrain from embarking as market prophets, considering the occupation as uncertain as that of weather prophets. But the following closing words from the address of the veteran manager of the Merchants' will surely inspire hope and give courage to every true Canadian heart:

"As men are concerned just now about the position of the country, I may say that it is 35 years since I first entered a Canadian bank. Thirty-five years is not a long time in the history of a country, but during this short period I have seen the deposits of Canada grow

from fifteen millions to two hundred and twenty millions. This fact speaks volumes. In view of such a result in so short a time, one would be pessimistic, indeed, to have any doubts about the future."

#### LUMBER ON CREDIT.

It is only giving expression to a common place aphorism to say, that credit is an absolute essential to present day business. The commonwealth exists commercially as a result of credit. The Budget speech, of every Finance Minister, tells the story of borrowing to meet the requirements of government. Nor is this condition applicable to the older communities alone. Their credit, it may be, stands higher than the newer countries, and they may have occasion to exercise it less. They all do business on it. And just so soon as this credit becomes impaired, as much in the case of governments as individuals, as witness Portugal and the Argentine Republic to-day, then follows disaster, and possibly bankruptcy.

This line of reasoning might be followed out, from the commonwealth down to the smallest huckster who paces our streets or tramps our country roads. It is obvious to everyone. Credit is good and necessary; but its abuse, like that of every good thing is bad; and it is abused badly in this age. Every trade can make its own application. There are no exceptions, not even in the field of banking, as is pointed out elsewhere on this page.

Our reference is more directly to the lumber trades, and to our own country. In the ELI page in last month's LUMBERMAN, the opinions of prominent dealers were given. This month ELI has talked with others, and their opinions are recorded. What is the credit given by jobbers to dealers? Never less than three months. The best firms expect it, as well as the weakest, and they will not be satisfied with anything less. The credit does not end here. Renewals are the rule and not the exception. One large firm tells ELI, that their renewals run not less than 40 per cent., and the opinion is expressed that the general average, throughout the trade, is higher than this.

We show elsewhere the small profits at which much lumber is sold, as a result of competition. Add to this the interest on the credit given, and it is hard to figure the margin of profit, be it ever so small, that should be behind every trade transaction.

There would seem to be an aggravation of the matter that goes beyond anything yet stated. It is only local to Toronto, but this is the more reason, seeing that all parties concerned, buyers and sellers are here, that the remedy should be applied. A jobber receives an order from a local dealer for a certain quantity of lumber. It is sold at closest price, and is shipped direct from the mill to the dealer in the city. Probably the freight is \$25. Who pays it? The buyer, as is usual in commercial transactions? No! The jobber must pay out in cash the freight, add this disbursement to the customer's invoice, and take a three month's note for the whole. In some cases this will be extended on another three month's or even longer.

We write in the interests of retailer, even more than jobber, when we say that these conditions are decidedly unhealthy. Three months time on a product like lumber, which calls for continuous outlay, from the tree in the forest until the manufactured article is turned out, is not safe trading. No such credit is given on lumber sold to American firms. They do not expect it. Cash or 30 days at the outside is the rule. Who will say that these men are less successful than our people? The contrary is the case. The long credits kill. "Numbers of our failures," says the manager of the Merchants Bank, "can be traced to it and a good proportion of our bank losses."

The evil exists. What are you going to do about it? It does seem to the LUMBERMAN that the jobbers have the remedy in their own hands. We would not say that the men engaged in this trade are so imbued with a spirit of jealousy, one towards the other, that they cannot be got close enough together to reach a conclusion, that would help each one individually and that would be a boon to the entire lumber trade. And most of all to the men today, who think they cannot exist without 3, 6 or 9 months time on their lumber. The very fact, that this time is needed, is the strongest evidence that at the best they are not more than existing.

THE LUMBERMAN suggests a prompt, practical and common sense move on these lines.

## EDITORIAL NOTES

THE statement of imports and exports from May 1st, 1889, to May 1st, 1890, and from May 1st, 1890, to May 1st, 1891, embodied in the report of the Minister of Customs and laid before the House at its present session, show the exports of the forest for 1890 to have been \$21,529,828, and for 1891, \$19,736,193, a reduction of \$1,793,635.

THE annual consumption of railroad ties is placed at 73,000,000, which requires 365,000,000 cubic feet of raw material. The opinion generally held by railroad managers that young wood is more desirable because it is young is erroneous. On the contrary, young wood, which contains a large amount of albuminates, the food of the fungi, is more apt to decay, other things being equal. Sound, mature, well grown trees yield more timber than very young or very old trees. It has been found that hewed ties will last from one to three years longer than sawed, and the explanation is given that the sawed face is more or less rough and collects the water and thus gives opportunity for fungus growth, while the smoother face of the hewed tie sheds the water.

"THE timber and deal trade with England," says the *Monetary Times*, "has had its period of reverse too, and the heavy losses made by shippers of last year can now be somewhat fairly estimated. It was in some respects the most disastrous year which the trade has experienced for a good while back. These disasters were not confined to the trade in Canada, in fact they only reflected the losses which had befallen the trade in the United Kingdom, where some old established and respectable firms have disappeared from the scene altogether, while others have had to put up with heavily diminished returns on their capital, or no return at all, if not a depletion of capital itself. In Canada there has been only one failure of magnitude in the trade; but this failure has entailed considerable losses to the banks with whom the firm did business. These losses have largely been confined to exporters. The manufacturers in the interior, whether of deals or timber, have escaped with little or no loss. A heavy curtailment of production is the only remedy for such a state of things as arose last year, and this curtailment has already taken place."

A RESOLUTION on the part of any branch of trade, to maintain prices, does not necessarily mean a "combine" to raise prices. Unfortunately the abuses of monopolies and combines have been so many, that when a body of business men form themselves into an association, the "cry" is generally raised that "here's another trust." The case is illustrated just now by the action of the lumber manufacturers of South Georgia, who have recently resolved to unite in an effort to maintain a living price for their product, as against the demoralizing "cutting," that has been prevalent among the trade in that section of the country. Certain members of the trade have refused to join the association, on the ground that the movement is one to prevent legitimate competition. The CANADA LUMBERMAN is not in position to confirm or refute this statement, further than the assurance of our esteemed contemporary *The Southern Lumberman*, that "if it is a combine it is in the defensive sense and not the offensive." We do know that there is an unfortunate disposition in nearly every section of country to cut prices, and that the real interests of many leading departments of business are discouragingly disorganized for this very reason. It is only common sense on the part of common sense business men to make any effort that will remedy this evil, and if this can be done by organization, who should object?

In an age when "diamond cut diamond" is the ruling policy of too many engaged in business, and where

one man's disaster is utilized for the gain of some one else, it is pleasing to note the disposition of the people of Winona, Minn., towards Messrs. Schroth & Ahrens: sash and door manufacturers of that city. This firm were unfortunate enough last month to have their extensive plant destroyed by fire. The total loss was \$90,000, with an insurance of only \$20,000. How did the fellow citizens of this firm show their regrets? At once, a voluntary act on their part, they went to work and subscribed \$10,000 to assist in the work of rebuilding. Accompanying the donation was a letter in which are recorded these kindly words: "While this is in the form of subscription, we beg leave to assure you that that which particularly and especially influences this action is the great respect and friendship entertained for each of you individually and the desire to show you the appreciation in which you are held by your neighbors. Were it not that business has for some time been dull the sum would have been made much higher." We hear more or less of "man's inhumanity to man;" here is an evidence of that touch of nature that makes a whole world kin. The firm in question have good reason to be proud of the esteem of their neighbors.

THE annual report of the Minister of the Interior just issued, shows the amount collected from timber dues in British Columbia and the northwest territories to be larger than those of 1889 by \$25,878.79. Of the revenue from timber, \$45,485.09 was derived from bonuses, ground rents and royalties on timber cut from lands in the railway belt in British Columbia, being an increase of \$27,440.32 over the previous year. An interesting statement of the report is that showing the decrease in the average prices of lumber within the several crown agencies during the last six years. The crown timber agent at Winnipeg reports that fuel is somewhat cheaper than last year, cordwood on the railway car at Winnipeg being \$2.25 to \$4 a cord for poplar and spruce, respectively; \$8 is asked for American anthracite coal on car, and \$6.75 for native soft coal. The regulations of September 17, 1888, governing the disposition of timber in Manitoba and the northwest territories, were, December 18, 1890, amended, so that licensees have now the option of either paying the royalty of 5 per cent. provided for by the regulations on the value of the lumber in the log, or at the period at which the lumber, when manufactured, is sold, and if the dues are paid at the former period the royalty is to be on the average price received for lumber during the three months next prior to the date upon which the dues are paid. The reason for making this change was, that in British Columbia it was found impossible for those persons holding licenses for Dominion and provincial lands, to separate the lumber manufactured from timber cut upon Dominion lands from that manufactured from timber cut on provincial lands. "It was also thought advisable to cancel the provision for a rebate of one-half of the royalty, amounting to about 25 cents a thousand, paid upon timber limits of Canada, and the order-in-council of December 18, 1890, above quoted, repealing section 20 of the regulations of British Columbia provide for a rebate of 25 cents a thousand on timber exported, but that it was considered that the timber on Dominion lands was more valuable than that on provincial lands, owing to the fact that the towage from the nearest point on the latter to Vancouver exceeds 65 cents a thousand, whereas from Dominion lands, it does not average 25 cents a thousand. It will thus be seen that the licenses of timber berths on Dominion lands, even although not allowed a rebate, have the advantage over those holding licenses for timber berths on provincial lands, who are allowed a rebate of 25 cents a thousand."

THE five colonies collectively, comprising the continent of Australia, annually import timber from other parts of the world to the value, at times, of over £2,000,000 sterling. This circumstance has set the Australians conning the problem of forest conservation. It is not alone the cost of present consumption that is considered, but the question is asked by the Director-General of Forests for the government of New South Wales, "if such is the annual value of the

imported timber at this comparatively early stage of our existence, as a nation, what will it be, say fifty years hence?" "And, secondly, will the supplies from which we now draw remain always available? Undoubtedly these are important and practical questions. The first carries its own answer, and the second, Mr. Brown, officer asking the question, thinks may be answered in the negative. Then follows the further comment: "what are the native timber resources of these colonies, and are they being utilized in such a way as to make the most of them?" It is understood that "kist woods, such as the tulip, cedar, blackwood, and mahogany are not as acceptable to the colonists as the imported walnut, ash, elm, and hickory, that yet they are in every way equal to the imported article. This argument favors the conservation of the ingenious forests, also the planting of exotic trees, which it is claimed can be successfully grown in Australia, both the soil and climate being suitable. We are not so sure that Mr. Brown is not a little Quixotic in some of his conclusions. It is doubtful if these antipodal colonies can within themselves grow woods that to-day they are importing. In any case, if we know anything of forest preservation in this part of the Empire, the contract to hold their own in native timber is large enough for present consideration. At the same time, we are glad to see our colonist brethren from "down below" taking so lively an interest in the question of forestry. It is one of these subjects, that requires all the enthusiasm that is likely to be thrown into it.

LAST year the Dominion government despatched William Ogilvie, the well-known explorer, to investigate the resources of the upper Ottawa and the country lying contiguous to the Hudson bay. His report has been laid before parliament, now in session. With regard to the timber resources of the district traversed by him, Mr. Ogilvie says: "It is needless to say anything of the timber resources of the upper Ottawa, they being well-known, but the country near the water shed we are not so familiar with. Here there is much red and white pine, with some fair spruce available, which will compare well in size and quality with a great deal that is now taken out. Timber on Barrier lake, Lonely river and Long lake, and its affluent streams can be directly floated into the Ottawa. That beyond the water shed, around Island lake and its affluents, can with very little trouble be floated into the waters of the Ottawa as follows: I have already mentioned that in high water the water from Summit lake flows both to the Ottawa and Abitibi. Now it appears to me that a few hundred dollars judiciously applied would make this exit to the Ottawa available for the passage of timber through it down to Long lake. By deepening and straightening Snake creek, which could be easily done, and placing a tug, such as is on Quinze lake, on Summit and Island lakes, all the timber around there could readily be placed at this exit and thence easily brought to the Ottawa by the aid of a tug on Long lake, Lonely river and Lake Barrier. As we approach Lake Abitibi the pine gradually thins out, until six miles below it, on Abitibi river, the last white pine is seen, and thenceforward we have only spruce, poplar and some birch and tamarack, of which only the first named is large enough to be of any commercial value. On the Moose river there are many spruce trees fifteen inches and upwards in diameter, and some balsam and poplar which could be utilized for many purposes. Very few trees were seen around James bay of large enough size for other use than fuel. In the vicinity of Rupert's house some building timber might be found, but not much suitable for any other purposes, the same remark applies to East main and all intervening country. If the timber on all the other rivers flowing into the bay is no more important than that I saw on the Abitibi, I would hesitate to call the timber resources of that district valuable, for though it is all thickly wooded only a percentage of it, along the river at least, is large enough for merchantable lumber. Yet the time is coming when it will have to be resorted to, and when this time comes we shall find ample water power on the ground for the cheap manufacturing of all the available lumber there, so that the consumer here or elsewhere will not be burdened with the cost of transport of the refuse part of it."



"THERE is really a vast difference," said Mr. Geo. Hastings, of this city, "between selling lumber to American dealers and to those in our own country. Here we sell everything on three months' time, and do a large amount of renewing for customers. An American firm never dreams of asking such terms. It is not an uncommon thing to receive back a cheque before the stock has actually reached the customer. There is a pleasure in cultivating a business of this character. But remember this, when you sell an American a certain class of goods, he wants that and nothing else. He is prompt and exact all around, and this is as it should be." In answer to the query, how is trade, Mr. Hastings reported it "quiet, though the outlook for the fall is fair, if the harvest turns out well."

"Lumber trade in New Brunswick," remarked Mr. R. B. Joyce, a former lumberer of that Province, and now located in Toronto, "is seriously affected by the competition of the Baltic. It is an export trade that the Province depends upon, and the cost of production has increased to that extent of late years, through increase of stumpage and other causes, that they cannot profitably cope with this outside rival. I wish it were otherwise, but I sometimes fear the best days of my old province have gone by."

I have heard of a Michigan lumberman, who has written to a friend in Canada, asking: "What in the old Harry the CANADA LUMBERMAN means by agitating this log question?" This hits my devoted head, and I wish my American friend to know that my hair is getting very thin about there. I have not done any agitating. My province is to give every one a show, and I have been letting the folks on both sides do their own talking. I must try and catch you, and get in your say, too. ELI is a free and independent elector, with no axe to grind; but he is dead anxious to further the interests of every lumberman.

I had a few words with Mr. Tennant, in his office on the esplanade, a week ago. He had just returned from the west, and reports a fairly active trade on the other side of the lines. "Yes," said he, "they have got over the labor troubles that threatened such dire disaster in the early spring. Prices are somewhat stiff. Good inch and half and two inch Canadian lumber is bringing \$3 a thousand more than a year ago." Mr. Tennant expressed the opinion that the reduction of the duty to \$1 a thousand had helped shipments to the States. One effect of the change, however, was to produce a scarcity of lumber here. Stocks just now were very low.

I have noticed in reading the news items of the LUMBERMAN that with few, if any exceptions, the shingle mills of this country are reported to be working day and night. Meeting a leading lumber merchant a few days since, I asked him to account for this. "It is owing," he said, "to the strong American demand for shingles. These people for some years past have been, to a large extent, using tin and galvanized roofs. Experience has proven to them, that these will not stand the weather, and they are now going back to shingles again. A 16 inch shingle is being used in most cases. Many lumbermen are cutting their rough logs into shingles and as they can sell them as fast as made, they get their money out of them at once. Prices I am glad to say are up a little."

"The flattening out of the real estate boom in the city," remarked Mr. Caldwell, manager for Messrs. Tennant & Co., lumber merchants, "has made local trade quiet. Real estate has tied up a good many people. Very little speculative building is going on today. The erection of small houses, such as was gone

into so largely a few years ago, is what created the demand for lumber. Iron and stone are chiefly used in the large buildings that are now going up in the city. Trade in the country is quiet, but we are looking for a good fall trade. Everything depends on the harvest. The farmers are the mainstay of our country towns. One bane of trade in Canada is the long credits. I have been trying for some time to get the lumbermen together in order that some arrangement could be effected that would end this kind of business. Think of such nonsense as the jobber paying out in cash freights on lumber shipped from the mills to some local customer here, and then taking the man's note for that which has been a straight disbursement on his part. And that kind of thing we are doing every day. The practice was started by a firm, who are to-day out of business, but it seems impossible to get any one back to sensible principles again." Mr. Caldwell reports that his firm are finding an increased demand for dressed lumber, and that they are having this work done at home, and to the satisfaction of customers, both as regards prices and character of work.

"Why should not the duty on hardwoods, as well as pine, be reduced to one dollar?" asked the manager of McEachren Bros., lumber dealers of this city. "Our trade is nearly altogether in hardwoods and we find ourselves a good deal handicapped by the duty. We pay it of course and not the consumer. It comes out of our price."

You have been through the States lately was the suggestive enquiry of the interviewer.

"Yes" said he, "I was all through Florida, Tennessee, Virginia and other southern States the early part of the year. To me the weather was delightful. I saw lots of yellow pine and I can believe all I hear about its growing popularity. It is a handsome wood, and of great length. But about that duty on hardwood. There should be free trade in lumber of all kinds."

Doctors will differ and so will lumbermen. We may have before us the same data, but it does not follow that we will reach the same conclusions from that data. I tell elsewhere on this page of a consignment of twenty-five carloads of lumber to a real estate dealer in the city. A well-known lumberman relates how the circumstance struck him. We give his story. I mentioned the fact to lumberman John Donagh. His impression was that the possession of so large a quantity of lumber by one outside of the lumbering business, told of a real estate dicker, rather than its use for building operations by or for the owner. "There is a good deal of trading in real estate these days," said Mr. Donagh, "and I have known men in the city to acquire quantities of lumber taken in a real estate deal with some one in the country, who owned, or found it to his interest to control, some lumber." Either interpretation may be correct, and both are probably typical of actual transactions occurring at times. There is very little, from a jack knife to a load of lumber, that cannot be concerned in real estate these days. I know of teas, sugars, pictures, printing due bills, and the dear knows what else, that have played a part in the sale of a piece of property. Anything will count, if only the property can be influenced to change hands. So much for real estate.

I have seen a letter, addressed to the publisher of THE LUMBERMAN, from a wholesale lumber dealer across the border, asking, "how to get the address of lumber dealers or manufacturers in Montreal and Ottawa." The parties writing the letter are subscribers to THE LUMBERMAN, and an announcement from dealers in these places would, of course, come before their notice. Others would also see it, for I am informed, that the request is not an unusual one. The letter is naturally suggestive of advertising. THE LUMBERMAN has no cause to complain in this department—at least, as an onlooker, it strikes one this way; the fact that so many of the best firms in the country, especially those engaged in manufacturing, use its advertising pages regularly, and some most liberally, is an unmistakable compliment to the merits of the journal as an advertising medium. I have been struck,

however, with the paucity of advertising from lumber dealers themselves. They have lumber to sell. The CANADA LUMBERMAN covers the whole field in Canada, of value to those who sell lumber, and it has also a wide constituency across the border. How many carloads of lumber would a dealer require to sell to cover the cost of an attractive business announcement in these pages? It is evident from letters such as we have quoted above—and it is no single instance—that there are new customers to be had, if our dealers will only let them know that they are doing business. A nod to a blind horse etc.

"A large amount of property in this city," said Mr. Meaney, manager for R. Thompson & Co., lumber merchants, of Bay St., "is not paying more than 2 or 3 per cent. on the amount invested. Toronto wants about 50,000 more people to drop in here—and to do so at once. Building has been overdone, and it is because so many people are loaded up with real estate to-day, that collections are slow. Have you noticed in the case of recent failures, what a large part of the assets of many insolvents is made up of real estate? We are forced in settling up with customers very often, in order to protect ourselves, to take over property of one class and another. I suppose it is better to do this than to make a clean loss, but in most cases we will have to "hold on" for sometime before we get our own back."

"I will tell you a funny thing that came under my notice a few days ago," continued Mr. Meaney. "I was signing the G.T.R. book in acknowledgment of an advice of a car load of lumber for our firm. I noticed the names of several other local firms for a carload each. Scanning the list more closely, I found a certain real estate dealer down for 25 car loads. We poor mortals could only buy one car load at a time; he bought in lots of twenty-five."

What significance do you attach to this? was the query. "It just means that speculative building in the city has reached a point where holders of real estate, who can manage it, find it necessary to hold even the lumber in their own hands, for the speculative builders are not in a position to command any credit. The owner of the land may be able to unload himself in part this way. If the builder can make anything beyond his wages all well and good. If not the other man takes no chances."

I found Mr. Meaney as I have found the lumber dealers generally loaded up on the question of long credits. "Take in the real facts," said he. "The lumberman starts into the woods with a lot of men. For cutting, logging, drives etc. he has got to put up spot cash, from the start. When the lumber is actually manufactured, it is a mistake and means a loss to sell it at once. Nearly two years go by from the time he starts to expend capital in its preparation for the market, before it is actually ready to sell. Then when it should be converted into cash, it is sold on three months time, and this credit is extended to the amount of one half by renewals."

Well remarked ELI no doubt you allow for all this in the profits.

"Yes we do" said Mr. Meaney with a quizzical smile. "Take bill stuff. It costs \$9 at the mill. The freight is \$2.75. We sell it for \$12 on time. Big profit, isn't it? And lots of margin for an occasional loss during the year. THE LUMBERMAN would be conferring a great boon on the trade, if it could do anything to get the dealers in this city together to talk over these matters in a common sense, business manner, as business men should always be able to do."

The venerable ELI, having his subject well in hand, was cruel enough to torture him with one more question before the interview closed. What about the duty that some folks are making a good deal of noise about?

"It has been a good thing for this section of country" was the response. "Our good lumber is worth \$5, a thousand more than it was a year ago. We can't credit all this to the duty, but it has had the effect of bringing the Americans over here and letting them see just what we have got, and in this way new trade has been created, and as a result of the increased demand has come increased prices. They have found that they can do better here than in Michigan."



## A BRITISH COLUMBIA SPECIMEN.

THE illustration on page five of this month's LUMBERMAN is a representation of an enormous tree to be seen in Stanley Park, Vancouver, B. C. Unless one has seen these giants of the forest it is hard to realize their enormous size. They constitute, as every lumberman knows, one of the main sources of the natural wealth of the Province. The great size attained by these trees has been attributed by so high an authority as Dr. Dawson to the mildness and humidity of the climate. The Douglas pine frequently exceeds 300 feet in height and is remarkably strong and straight.

## FASHIONS AND FADS IN THE LUMBER TRADE.

THERE is one thing that defies human foresight to predict and all human laws and efforts to control. It is fashion. No human foresight can predict when, where, or in what shape it will start up, or in what direction it will trend. It is essentially a child of Civilization and its wildest modern vagaries mark but successive steps from barbaric splendor to the height of culture. It is the one omnipotent power that rules modern civilization and culture with a tyrannic despotism more inflexible than the barbaric ages ever knew.

It would seem that, in this utilitarian and practical age, if there is any industrial interest that would be entirely free from all influence of the tyrant Fashion it would be the lumber trade. But it is not. Fortunes have been made and lost in the lumber trade upon a whim of Fashion. Some years ago Fashion issued a decree that all the world should skate, regardless of climate, weather, and thermal conditions. Lumbermen made fortunes building rinks to supersede frozen water, and the world was ransacked to find suitable timber to makerollers for skates. Millions of money were invested in the manufacture of roller skates, rinks, and the patents that covered their mode of construction. The forests of Asia Minor were "denuded" to some extent of boxwood timber to make the rollers, and that wood, at one time, was worth almost its weight in silver, and figured largely in the national tariff revenues. Suddenly Dame Fashion issued a decree of disapproval of the sport, and as suddenly half made fortunes crumbled into bankruptcy.

About, or soon after, that time Fashion decreed that the sporting and pleasure seeking world should devote its attention to another athletic sport—base ball. As usual, the lumberman were called upon to furnish their part of the outfit, and it proved a small bonanza to some of them. One obscure hamlet in Tennessee furnished as many as one hundred cars of ash base ball bats in a single year. Recently the demand for this kind of wood work has fallen off to almost nothing, and there are some anxious inquirers among the lumber fraternity who want to know what Fashion is going to do about the game. This is a question no one can answer positively. Under the league system of professionals the business was overdone. It requires no special mental training, no moral character, or other trait except physical vigor and practice, but experts soon commanded salaries exceeding those paid our high judicial and executive officers, or the most eminent divines and scholars. If Fashion were governed by sense or any known law of reason we should think the professional game is "out of fashion." As a college game, among non-salaried amateurs, it is well enough, and will probably always be in fashion, but the tribute it will pay to the lumbermen will be comparatively small. Those who are now discussing whether the present condition of the game is only a temporary depression or a permanent decadence, refer to the English national game of cricket as a hopeful example. They say that game has been played in England for centuries and is still popular, and many think base ball will revive. May be so. No one can tell, but this is not a good time to invest money in machinery, plant, or timber for the manufacture of base ball supplies.

THE forest fires where damage has been done to live timber are likely to result in considerable summer logging being done. The timber will be cut to save it from destruction by the worms and the elements.

## BRITISH COLUMBIA LETTER.

## A Brisk Import and Export Trade—B. C. Fir vs Oregon Pine—Personal and News mention.

[Regular Correspondence CANADA LUMBERMAN.]

ALL the mills in British Columbia are taxed to their fullest capacity to fill orders for local trade and export. The great scarcity of bottoms still continues and the amount exported is curtailed for this reason. It is a surprise and cause of wonder to many that the export mills in British Columbia have more orders than they can fill, for the above reasons, while the mills on Puget Sound are either closed down entirely, or only running half time, from want of orders. The explanation seems to be that the timber from B. C. finds more ready sales.

The Boards of Trade of New Westminster, Vancouver and Victoria are trying to have B. C. lumber and timber quoted and separated from "Oregon Pine" in the circulars and trade reports of Australia. Now it all goes in as "Oregon Pine" which is unfair to B. C. Fir.

The Canadian Pacific Lumber Co. have concluded the purchase of five acres of land near the head of Lulu Island from Mr. D. McGillivray on which they will build their mill. The purchase price was \$5,000. Work on the mill has been commenced. The machinery has been ordered and is expected here shortly. A rumor is abroad that a well known manufacturing firm will amalgamate with the Canadian Pacific Co., but at this writing it lacks confirmation.

Messrs. Murray Bros. have opened a retail lumber yard at Mission City and are now ready to fill all orders for building and finishing lumber.

Morton Bros., mill on the Nicomeckl River is kept busy at local work.

The R. C. P. mills Co. daily ship from 3 to 5 cars of lumber east per C. P. R. and the Brunette Saw Mill Co. is increasing their trade east of the Mountains, every mail bringing in orders. The new mill is working to the satisfaction of the management. Mr. John Wilson, late of Ottawa, is now manager and H. L. Debeck, secretary. This change was made at the last general meeting of the Co. held in New Westminster last March.

T. S. Higginson Esq, crown timber agent, is still very unwell and feels the effects of his accident received in the C. P. R. accident at Schreiber, some time since.

The output of the Westminster mills for the year ending May 1st is placed at one hundred and fifty million feet of lumber, the value of which would be about \$1,875,000. This is exclusive of laths and shingles. It is estimated that forty five million shingles were also turned out, which would mean at least \$135,000. There were fifteen million laths, which would aggregate \$37,500. Of the above production it is estimated that at least one-half was exported to foreign countries, such as China, Japan, India, Australia and the United Kingdom, while the other half was utilized at home.

The genial and capable manager of the MacLaren Ross Lumber Co. Mr. R. H. O'Hara, has resigned. He left for the east on 24th inst. H. G. R.

New Westminster, B. C. June 25th 1891.

## LUMBERING—THROUGH WOMAN'S GLASSES.

THE following sprightly sketch of the Longford Saw Mills is written by "Madge Merton," editor of the woman's department of the *Daily Globe*. It is readable, because of its brightness, as well as presenting an interesting picture of life in the lumbering regions, as seen by a woman. She says:—

"Five miles from Orillia across the Lake Couchiching is the little lumbering settlement of Longford, owned by Thompson Bros. The three-fourths of a mile from the dock to the large mill is a pretty drive past full-leafed woods, stony, rolling ground and the ruins of an old tramway, which has fallen into disuse since the entrance of the railway.

"Alongside the mill is Lake St. John, a pretty, glassy-surfaced sheet of water four miles long. Near the shore the logs were lying ready for their quick passage through the noisy mill, with its executive committee of saws and men. How the saw dust, splinters, blocks and chips come tumbling down the shafts, for the waste

feeds the furnace. The two great engines hissed, the floor shook as they trod their measured way and I could easily believe they were doing the work of a hundred and twenty horses. Up above we saw the wet logs come up and watched the saws bite into the pine, casting to one side the tough brown bark. The bands and pulleys seem to whistle as they spun around and the men strained every muscle, for the whirling machinery waited for no slow hands or wearied bodies. The circular saws hissed spitefully as they cut the timber even and the noise of the planks falling upon the pile was lost in the commotion.

"Standing near the lath machine we watched the slender sticks come out ready to be sorted into bundles. The hiss of the saw was of shorter duration, but further over the busy, larger one filled the second's interval with its monotonous buzzing.

"We climbed up to the door of the big sheet-iron burner, in which the useless saw dust fell to be consumed, and stared with horror-startled eyes down into the flames. They leaped towards us with a roar. The hot smoke rose in clouds and the sparks danced in them like shooting stars.

"At the smaller mill I was much interested in the emery wheel which sharpens in an hour a big, wicked looking saw which by hand required a-half day's labor. How it ground against the metal, flinging sparks out into the air, reminding one of pin-wheel fireworks on Dominion Days!

"A store, telegraph office, post office, church, school and free library are the town part of the settlement, and the little cottages for the married workmen are prettily situated away from the mills, with two large boarding-houses for the unmarried ones.

"In passing a stone quarry I learned that stone was being shipped from it for the new Toronto City Hall building. To the north the bush fires were raging and the smoke drew the horizon close about eyes which were aching to look beyond it.

"High piles of lumber rose above our heads till it seemed as if pigmy horses and dwarfed people were moving along the winding road. "Ten millions shipped since January and 120 M cut in the big mill in a day." was the owner's answer to my queries.

"The air was spicy with the odor of the fresh-cut pine, and the sun was red in the smoky atmosphere as we boarded the little steamer on our return journey. All the way along a band of sunset-light stretched between us and the west, startled into sparks as the disturbed water flowed away from the path cut by the prow. Grey-hued in the smoke lay Orillia with its tiers of tree-crowned terraces stretching above the water front of the calm little island-dotted Lake Couchiching

## TRADE NOTES.

The firm of Burns & Thomas, saw manufacturers, of this city, has become the E. R. Burns Saw Co., Mr. Thomas retiring. The saws of this company, of whatever kind, have ever taken a first position. Circular and long saws of all kinds can always be had from them.

It will be of interest to our readers to know that the Waterous Engine Works Co., of Brantford, have a band saw mill expert from the States in their employ, who, they will be glad to send out of any mills requiring the service of a man to put their saws in order and give them instructions in running band saws.

The Cant Bros. Co., of Galt, have just brought out a new and improved hub boring machine with a self-centering chuck, capable of receiving blocks from 3 inches to 22 inches diameter, and of boring or reaming either straight or taper holes from  $\frac{7}{8}$  of an inch to 5 inches diameter. The hole is bored in the block complete at one operation to the proper size and taper, so as to fit the hub lathe mandrel on which the block is turned and finished. The carriage is mounted on and gibbed to a stout wooden frame, and will neither leave its bearings nor spring even when performing the heaviest class of work, and it slides to and from the boring tool easily and accurately by means of a large hand wheel. When the carriage is moved to the back end of the machine, the block can be readily placed in and taken out of the jaws, which are operated by hand wheel and gearing.

## THE NEWS.

### ONTARIO.

—Ottawa river is now at its nominal height.

—The saw mills at Burk's Falls are busy cutting.

—Trenton notes their first drive of logs last week.

—McMillan's saw mill at Morris, is running full blast.

—What about the news of your district? Send it along.

—Messrs. Elliott & Co., builders, Toronto, have assigned.

—Business is rushing at Donaldson and Perdue's at Bayfield.

—The planing mill of Mr. Eaton of Orillia is being enlarged.

—Robert Sampson's mill at Pt. Alma has started for the season.

—Wages in the lumber industries of the Ottawa have been reduced.

—Deals for England are being shipped by Mr. J. R. Booth of Ottawa.

—The E. B. Eddy Co. are converting their saw mill into a paper mill.

—A saw mill is being erected at Otterville by Messrs. Kay and Smiley.

—Potter's saw mill at Little Current is being run to its fullest capacity.

—A drive of 40,000 logs of the Rathbun Co. passed through Yarker a week since.

—A large quantity of valuable lumber is being cut this season at Sturgeon Bay.

—The Rathbun Company have purchased 200 carloads of timber at the Mississippi.

—Every lumber firm on the Ottawa, it is said, will work limits next fall and winter.

—Mr. Jaynes, of Sturgeon Bay, has been perfecting the machinery of his shingle mill.

—The saw mill of Mickle and Dymont at Bradford gives employment to about 50 men.

—Pierce & Co's. mill on the Ottawa, which is at present idle, is to be sold next month.

—Active preparations are being made for the building of a saw mill at Saltford, Huron Co.

—The Buel, Hurdman & Co. mills at Ottawa will run day and night during the season.

—W. B. Fotheringham, saw mill man, at Rainy River, Ont., has assigned to Campbell & May.

—The big saw mill at Bradford commenced operations on 2nd ult., and will run about four months.

—The steamer "Rush" is loading lumber at Ottawa for the Bronson & Weston Lumber Co. at Rockcliffe.

—The Parry Sound Lumber Co's shingle mill is running day and night to meet the demand for shingles.

—Logs in large quantities are being shipped by Messrs. Broxton and O'Connor to the Chatham Mfg. Co.

—The tail of the first drive of saw logs down the Moira passed through the boom at Belleville on 17th ult.

—The S. S. Africa and her tow cleared Collingwood last week with about a million feet of lumber for Tonawanda, N. Y.

—Mr. E. B. Eddy has erected a new black-smith shop next to Hurdman's mill, Ottawa, the dimensions being about 30x40 feet.

—Rivermen from up the Gatineau report that the log drive on the Blanche, which is making its way down, will be an unusually large one.

—Long trains laden with logs come into Deseronto every night over the K. N. & W. Ry. from the Mississippi River via Harrowsmith.

—Earncliffe, Ottawa, the late home of Sir John A. Macdonald, was formerly the property of Mr. Jas. McLaren the well-known Ottawa lumberman.

—Both Booths and Hurdman's piling grounds on the Hull side of the Ottawa present a deserted appearance, most of the lumber having been disposed of.

—The new card board factory of the E. B. Eddy Co., Ottawa, started operations on the 20th ult. The card board is made entirely from spruce pulp.

—The Export Lumber Co. have built a track from the Chaudiere branch of the C. A. R. on the line between their piling grounds and those of J. R. Booth.

—The Capital planing mill company's new factory at Stewarton, near Ottawa, is now running and a large amount of planed lumber is being turned out daily.

—The Red mill stock of lumber at Little Current, also Messrs. J. T. Conlon's cut for this year, has been purchased by Mr. W. H. Bellinger of Tonawanda, N. Y.

—Messrs. Mitchel Bros. of Owen Sound and Lucknow are doing a large export trade in hardwood, principally maple, to England. Their mill is running day and night.

—Fishery Inspector Ramsay has caused Messrs. Gall, Anderson & Co. and Knight Bros. of Burk's Falls, to be fined \$10 each for allowing saw dust to get into the river.

—A fine class of logs is reported as coming down the Severn and which are being converted by Mr Rowland and his men into lumber at the rate of over thirty thousand a day.

—Deals and boards for the Glasgow market are being shipped from J. R. Booth's mill, Ottawa. Already eight barges have left, each carrying over 300,000 feet of lumber.

—The Rathbun Company's mill at Rossmore has been abandoned and is in course of dismantlement. The boilers are out and the order for the removal of the smoke stacks has been issued.

—Only Bronson & Weston's and Perley & Pattee's of all the mills on the Chaudiere are running on full time. An army of workmen walked the streets of the Chaudiere through lack of employment.

—Twenty-five thousand ties for the Grand Trunk Railway and 1,000 cords of wood for the Napanee Cement Works and Deseronto chemical works will be taken out of the Napanee mills this season.

—Bronson and Westor's and Perley and Pattee's mills on the Chaudiere are running with large gangs. J. R. Booth's large mill is not yet running. A dearth of employment for workingmen is reported.

—The Rathbun Co's mill at Lindsay, which was thoroughly overhauled this season, and a number of improvements introduced, gives employment to about thirty hands. The season's cut will be a very large one.

—Bently Hurley who presented a false invoice when he entered some lumber at Pt. Lambton and then had the lumber seized by Customs Officer Deming has paid up and taken the lumber. It cost Hurley only \$150.

—Trouble, is reported in connection with the timber cut on the Indian reserve at Manitowaning. The department have put on men to scale the lumber over again and Burton Bros. have been forced to move the logs until the scale is completed.

—The first drive of the season passed through Young's Point on 1st ult. The Lakefield Lumber Co., Dickson Co. and the Messrs. Gilmour will each follow along with drives. These are expected to make the sum total of drives for the season.

—The tug Peter Smith passed through Little Current on the evening 15th ult. bound for French River. This is one of the large American tugs which belong to the company which have contracted for the towing of Howry & Co's. logs

—The piling grounds of J. R. Booth, in Rochesterville, are being improved by workmen. On both sides of the Cedar street school the ground is being levelled, and next a steam shovel is to be put in to remove the large hill below the school.

—Messrs. Heath, Tait and Turnbull, of Huntsville, are cutting shingles at the rate of 5,000,000 per month and are likely to make a total cut for the season of at least 30,000,000. The Edison electric light is used in the mill and the firm are sawing shingles day and night.

—The Parkdale Lumber, Manufacturing and Building Company have decided to discontinue as a joint stock company, and, by a recent arrangement, Messrs. Coxhead and Ingham will operate the planing mill and factory, and Mr. James Stewart will take over the lumber business.

—T. H. DeCew, of Essex in company with Mr. Scott, of Portland, Ore., purchased 1,600 acres of fine timber land in Oregon. Mr. DeCew reports it as being the finest timber he ever saw; says he has heard of such trees but never expected to see them. On one acre he counted 26 which would average 10,000 feet of timber each. The average here would be about 1,800 feet. One large tree they estimated would measure 35,000 feet. Any number of them would yield straight logs 200 feet long. Mr. DeCew is thinking of returning this month and buying another section of 640 acres in the same locality as the other.

—June 19th recorded the arrival of the first raft of the season at the foot of Parliament hill, Ottawa after a voyage of seventeen-days from Des Jouchims. It consisted of some 123 cribs of fine, clear, square timber, belonging to the concern of Thistle, Carswell & Francis, and was taken out last winter on the Petewawa river. The raft was in charge of Francis Paul, the veteran river-man, who in the past forty-six years,

has brought a total of 112 rafts from the Upper Ottawa down to the Quebec market. Not more than a dozen rafts of square timber will be brought down this season, as compared to nearly a hundred last season.

—The case of C. P. R. v. J. K. Lawton and Blind River Lumber Company has been concluded in Court of Appeal, judgment being reserved. The C. P. R. and lumber company had mills some two miles apart, and to avoid the expense of moving logs through Lake Huron an agreement of exchange was arrived at. After exchange had been made both plaintiff and defendant complained of injustice, and Peter C. Campbell, the Crown Timber Inspector for Algoma was called in as an arbitrator. After hearing the evidence Campbell ordered the C. P. R. to pay Lawton \$5,861.71 and costs. The C. P. R. appealed and Judge Falconbridge refused to set aside award, and litigation was the outcome of the C. P. R's. second appeal against the decision of Judge Falconbridge. The plaintiffs claim that Campbell, being a servant of the Ontario Government, was biased against them, and again that fraud was used to gain the award.

### QUEBEC.

—Mr. G. N. Vancor, of St. John, has changed his property at this point for land and mills in Lawrenceville.

Ross Bros., of Buckingham, are busy repairing the ravages to their lumber slide caused by the great land slip back of the Presbyterian church lately.

—"One thing that has contributed in some measure to the falling off in business at this port is the fact that no lumber is being sent to South America," said a steamship man to a *Star* reporter at Montreal. "Last year, not a single deal was sent, but this season not a single cargo has gone to the River Platte, and what is more, there is no lumber even on the wharves."

### NEW BRUNSWICK AND NOVA SCOTIA.

—The exports of St. John, for May, were valued at \$485,497 as compared with \$316,492 in May, 1890. About \$293,000 of this consisted of products of the forest.

—The St. John schools have had a voting contest for the most popular native tree and flower. For the tree 4,492 votes were cast, of which the maple received 2,934. The elm was second. For the flower 4,635 votes were cast, the rose getting 2,691. The lily was second.

—The Tracadie river steam saw mill, with 200 acres of land have been sold, to the Bank of Montreal. The mill formerly belonged to the Sweeney estate, but was mortgaged to Messrs. Stewart, and on their failure the mortgage was handed over to the Bank of Montreal. Mr. C. W. Weldon bought the property for the bank at \$7,000.

—Two more rafts of timber, containing 8,000 sticks each, are soon to be started from the St. John river, to New York, by the irrepressible John D. Leary. They are to be made up into a series of short rafts, connected like a train of cars and the work of removal will be begun as soon a freshet occurs in the St. John river. Before reaching navigable water the great cribs will be taken in tow by two powerful ocean tugs and towed to New York.

—The Fredericton Boom Company has about completed an ingenious contrivance to be used for the purpose of expediting the loading of rafts, which ordinarily is a work of much labor, and employs several hands in taking the boom poles, used in bracketing, from the water. This machine is intended to do that work. It was designed and is being built under the supervision of Charles H. McClusky. A frame is placed on a raft bearing a horizontal shaft. On this shaft are two toothed wheels about 12 feet apart. Over each of these wheels passes an endless slot chain, with claws fastened to the links at intervals of two feet. These chains work over pulleys at the end of inclined planes under water. The boom poles are floated to the side of the raft, and come directly over the chains, which as the wheels revolve carry the poles up on the raft. It is a new style of elevator and pretty costly, but will very much lessen the work in labor and expense. All of the booms will be furnished with the machines.

### MANITOBA AND THE NORTHWEST.

—M. S. Ryan, lumber and mills, Millville, is dead.

—Messrs. Mann & Durham, of Brandon, lay claim to the only covered lumber yard in Manitoba.

—Brandon lumber dealers, a local exchange says, are cutting rates with a vengeance. Foolish fellows.

—Kahl & Deary's drive reached Rainy River a week since. They brought five million feet of logs for the Keewatin Milling Company.

—J. H. Hughes, of Rat Portage, has got his mill running, and says that he will cut and bring to Brandon, 3,000,000 feet of white pine lumber this season.

—Upwards of 200,000 young forest trees have been sent from the Central Experimental farm at Ottawa this season to the Northwest Territories and Manitoba.

—A. H. VanEtten has sold his lumber yard at Winnipeg, to the Western Lumber Co., Ltd., of Rat Portage, Ont. Mr. VanEtten will remain in charge of the business as agent for the Western Lumber Company.

—August Pufal is the champion poplar peeler of Manitoba. He peeled 42 cords of poplar in seven days, in the bush of Hugh F. Coburn. Two dollars and fifty cents is being paid for poplar by Mr. J. H. Bromley, and he has already bought 4,000 cords, and it is not unlikely that he will run his purchases for the season up to 10,000 cords.

#### BRITISH COLUMBIA.

—Ward's shingle mill, on the North Arm, is very busy shipping to the interior.

—The barque *Ondovic* is loading lumber at the Hastings mill, Vancouver, for Callao, Peru.

—The Brunette mills at Sapperton are running overtime. They are shipping daily to the eastern markets.

—Murray Bros., local lumber dealers at Mission City, have just received a shipment of 200,000 feet of lumber.

—The Canadian Pacific Timber and Lumber Co., have concluded a contract for the getting out of two million feet of lumber near Sechelt.

—McLaren & Co.'s new circular saw mill at New Edinburgh, has commenced running. This firm carry heavy orders at present for supplying dimension timber.

—The residents of Moodyville are talking of starting a shingle mill, the stock to be owned by the residents of the Port. One hundred thousand feet a day is to be the output.

—The Shawnigan Lake Lumber Co. are going to increase the capacity of their mill and are putting in additional machinery, which will increase the cut to 40,000 feet per day. This is consequent upon the increasing demand the company have found for their fresh water lumber.

—Mr. John Patteson, of New Westminster, is credited with the "find" of a splendid stretch of the finest timber, some 45 miles from the Squamish. It extends for upwards of 100 miles and is composed of fir and cedar—some of the latter measuring 18 feet in diameter, six feet from the ground.

—The largest cargo of lumber yet exported from the mills on Burrard Inlet was that of the steamship Eton consisting of 1,765,714 feet. The steamship Remus cleared November 19 with 1,591,344 feet lumber and 6,148 bundles of laths; both of these vessels were loaded at the Moodyville saw mill.

—Johnston Bros. are rapidly surpassing the estimate of the quantity of lumber they expected to get from their camp at Port Moody. It has been said by those qualified to speak on the subject, who have visited the camp, that the quality of the cedar they are getting out is unsurpassed in British Columbia for making shingle bolts.

—It is reported that Mr. J. A. Carthew, the well-known capitalist, has purchased the Gamble saw mill and cannery site on the Skeena, midway between the Standard cannery and Port Essington, and will at once proceed to erect thereon a saw mill, the power being derived from two turbine wheels, of 150 horse power each. The location is conceded to be the finest for the purpose on the Skeena, and Mr. Carthew has already orders enough in view to keep his mill running to its full capacity all through the season.

—The sale of the Moodyville Saw Mill Co.'s property to a foreign syndicate of wealthy capitalists has been finally completed, and a heavy deposit made as representing the bona fides of the parties who have made the purchase. The transfer takes place on the 1st of July when the new owners, in addition to assuming control of this very valuable property, will enlarge the cutting capacity of the mill to more than double the present output. The property will be cleared and laid out into city lots, sufficient, however, will be retained for the actual requirements of the company in connection with its manufacturing and shipping business. Other industries besides the saw mills are to be located there, of which fuller particulars will be made known hereafter. The consideration paid for the property is one million dollars. It embraces the mills and some 400 acres surrounding the village, about 6,000 acres of timber and prairie land on Mud Bay; several hundred acres of land across the Inlet from this city and leases covering timber limits which will supply the mills with logs for the next 50 years, if double its present capacity. The property has a foreshore frontage on the Inlet of about four miles, affording unrivalled shipping advantages. Amongst the names of the purchasers are those of Rothschilds and other well-known London capitalists, who are determined to make the estate a valuable one by establishing industries, building streets, operating electric tramways, ferries and railways in that locality.

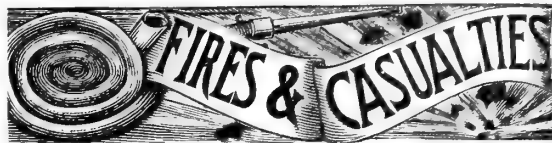

#### FIRES.

S. & R. Nixon's saw mill, Nictaux, N.S., has been burned out.

Fires have been raging on the limits of the Pembroke Lumbering Co.

James Calder's saw mill at Clayton, Ont., has been destroyed by fire.

The portable mill of Harvey Bros., of Udora, was destroyed by fire a week since.

Mr. James Playfair's mills at Sturgeon Bay, Ont., were destroyed by fire on the 12th ult.

Robinson & Co.'s planing mill at West Selkirk, Man., was slightly damaged by fire on the 8th ult.

Graham's shingle mill at North Chaffey, Muskoka, was burned down the first week in the month.

Higgins' mills at McGregor, Ont., were destroyed by fire a week since. The entire village was nearly wiped out.

Contractor Donald Grant says he lost 15,000 railroad ties by the recent fires along the Duluth and Winnipeg railroad in Minnesota.

Forest fires are reported to be raging on the south shore of the St. Lawrence east of Father Point, which are exceedingly bright at night.

Bush fires have been raging in northern New Brunswick, destroying much valuable timber and other property. Over 100 miles of country has been devastated.

The saw mill of Paul & Wiseman at Havelock, Ont., was destroyed by fire the first week in June. Loss \$2,000. Insurance \$1,000. They will rebuild immediately.

On morning of 24th ult., the heading and stave factory, Grey, Young & Sparling Co., Seaforth, Ont., was seriously damaged by fire. Probable loss \$4,000. Insurance \$2,000.

On 4th ult. the mill belonging to Mr. Alex. Alves, on the shores of Parry Sound, was destroyed by fire, together with a quantity of hardwood lumber. Loss \$2,000. No insurance.

The mill of D. Brown, Forrester's Falls, Ont., was burned down on morning 2nd ult. Included in the conflagration was 75,000 shingles belonging to Mr. Jas. Davison, of Beachburg.

Jackson's pulp mill at St. Raymond, Que., was totally consumed by fire on night 4th ult. The mill cost \$49,000. Insurance about one-third. About 40 hands are thrown out of work.

Fire got into Whiteside's tent, at Huntsville, used by his men driving logs on the river, while the men were away at work and consumed the tent, blankets, grub and the whole business.

The saw mills of the Casselman Lumber Company, in the village of Casselman, on the line of the Canada Atlantic railway, were completely destroyed by fire on night 15th ult., together with a quantity of lumber the property of the company. Fully insured.

The warehouses and dock property of the Rathbun agency, Belleville, Ont., had a narrow escape from destruction by fire on 8th ult. A spark from the *Hero*, which had been lying in port over Sunday, lodged in a pile of cut wood and the heavy wind fanned it into a flame. The steamer hands were fortunately "on deck" and prevented what might have been a disastrous conflagration.

On 18th ult., a fire in the woods to the north-east of North Bay, Ont., fanned by a strong breeze, threatened disaster to the town, but by persistent efforts of the townspeople, who were very ably assisted by the Canadian Pacific railway employees, the hose was soon laid from the company's works and a stream poured into the fire, which with the pail brigade soon brought the fire under control without the loss of a single building.

—The depot of McLachlin Bros., Aylen lake, near Kingston, Ont., was burned on 18th ult. The buildings took fire from bush fires raging in that section. As this is the principal depot on the Madawaska limits of that firm, the loss will be very great—said to amount to fully \$75,000. Nothing was saved except some barrels of flour and pork, rolled to the shore of the lake. The loss includes over 6,000 bushels of oats, 100 tons of hay, sleighs, harness, flour, pork and shanty material. Some of the settlers have also suffered. Miles of country are in flames, and the loss of valuable timber must be great. McLachlin Bros. have sent a large number of men to fight the fires on their limits. Men have also been sent up

by J. R. Booth to his limit. The same is true of the other limits. Fires are also raging. It is reported that Egan Estate, on the Madawaska, has been burned with its contents.

#### CASUALTIES.

Murdoch Campbell, of Seaforth, Ont., lost a finger in Broodfoot's planing mill on 26th ult.

A man named Remon, aged 63 years, was drowned at Perley & Pattee's boom, Ottawa, on 6th ult.

A tumor weighing six pounds was successfully removed from a horse belonging to the McLaren-Ross Lumber Co., New Westminster, B.C.

John Sabiston, one of the employees of McArthur's mills, Fairford, Ont. was caught in the milling machinery and almost instantly killed.

A young man named Marcus, lost an eye at Watson Bros.' mill in Ridgetown a few days since, from being struck by a piece of heading.

Mr. Harwood, whilst loading shingles at the lumber yard at Tavistock, Ont., was thrown from the waggon a distance of 25 feet, receiving severe injuries.

A man named Parke, an employee of the B. C. M. T. & T. Co.'s factory, New Westminster, B. C., caught his arm in a boring machine and had a hole drilled into it.

A barge of Messrs. Brown & Rutherford, of Selkirk, Man., ran aground a few days since and a large quantity of the lumber was blown off the deck by the high wind.

An employee of the B. C. M. T. & T. Co., New Westminster, had a hand badly mangled on the 11th ult., by the breaking of a belt connected with a feeder he was managing.

A man named Matthews, working for J. Whiteside, Huntsville, driving logs, had three of his ribs broken a week ago, by a rope breaking from its fastening and striking him.

A boiler explosion occurred on the premises of the Grand River Manufacturing Co.'s excelsior works a week ago, resulting in the death of Mr. Wm. Ariss, who was driving the engine.

A scow at Bradford, Ont., loaded with lumber and lath, collapsed and sank, a few days since, and it was quite a picnic for the boys to gather up the lumber and place it on a barge which came to the rescue.

At the Conger mill, Parry Sound, the first week of the month, Walter Moulton suffered a severe wound in the leg, through having a hook driven with considerable force into a point near the abdomen.

Mr. John Venson, in the employ of Mickle & Dymont, Bradford, met with a serious accident on Tuesday 2nd ult. by which his spine was injured and his body badly bruised. He was thrown from the log carriage while in motion.

Mr. D. Sutton, of Pt. Arthur, Ont., and who was engaged by Vigers Bros. in connection with the work of pile driving at Fort William, while in the discharge of his duties had his jaw bone broken by a spike flying through the air and striking him in the face.

Robert Scott, lumber inspector, residing at Bradford, Ont., the latter part of May, met with a serious accident at North Bay. He attempted to board a flat car on the tracks while a train was in motion, and, slipping, fell with his foot on the track. It was so severely crushed that the leg had to be amputated.

Two men named Paquette and Tremblay lost their lives on the Gatineau, near Ottawa, on the 11th ult. They were at work at Aylen's chute, which has three falls narrowing at the bottom, each one of which is worse than the Chaudiere. The men were swept over these boiling waters to death below.

Frederick Herman, an unmarried man, who has been engaged for some years past on Mr. J. R. Booth's log railway, between Lake Nipissing and the Mattawa, met with a very painful accident on 20th ult. In endeavoring to escape from a stick of cordwood that had fallen from the top of the engine tender, he slipped and was thrown heavily against a pile of ties at the side of the road, breaking his leg below the knee and sustaining other injuries.

#### PERSONAL.

Mr. Isaac Cockburn, one of the lumber kings of Muskoka, has returned home from a trip to the Pacific coast.

Mr. Frank Nolan, head sawyer for J. B. Smith & Sons, of Franks Bay, is holidaying with his family at Angus, Ont.

Mr. W. R. Thompson, wholesale lumber merchant, Teeswater, favored THE LUMBERMAN with a call on 12th ult.

Mr. J. A. Spaulding, wholesale lumber dealer, Philadelphia, and Mr. E. B. Foss, Michigan, favored THE LUMBERMAN with a call during the past month.

Mr. W. E. Dodge of New York, president of the Georgian Bay Consolidated Lumber Co., with his family are putting in a vacation amid the Muskoka lakes.



TRADE REVIEW.

Office of CANADA LUMBERMAN June 30th, 1891.

IT CANNOT be said, that there has been any remarkable activity in trade circles during the month. Mid-summer is near enough to void any thoughts in this direction now. Nor do any discouraging features exist: two small failures only are to be recorded in local trade circles; whilst the expectations of country trade are hopeful. The depression in building in the city has its basic origin, as we have pointed out before, in the falling off in speculative building, caused by the unsatisfactory conditions of the real estate market. This must be viewed as a healthy omen of the future, rather than the opposite. Speculation in any line of trade, though giving at times a spasmodic push to business, is never enduring, and will always be followed by reaction and disaster. Even business men, noted for caution and shrewdness, in their regular business undertakings, lose their heads, when the spirit of speculation—developing into a species of gambling—takes possession of them: whilst the "smaller fry," when the storm is over are like to the sands on the seashore in number; to be found scattered, hither and thither, and everywhere.

Country trade is dependent on the harvest. It is early yet to prognosticate with any measurable certainty of hitting the mark. The outlook, however, at this writing is fairly promising. In western Ontario the prospects have more than a single ray of sunshine to lighten up the future, and travellers tell us that they anticipate a good demand for lumber in these parts in the fall.

An abundant harvest will of course affect trade everywhere. When the "farmer is on top," the commercial thermometer, wherever placed, will rise. Money once more moving actively and there are "none too poor" not to feel its benefits.

The best of the season's trade with the States is over as is shown by the falling off in shipments to the other side during the month. The shipment of deals from Ottawa to England this year has exceeded that of any previous year. It is stated, that all the stock deals in England are sold, and that green deals, fresh from the saw mill will be shipped by the end of next month. Ocean freights for deals are very low this year.

Prices are about the same as last month. For higher grades, this of course is an improvement on the figures of a year ago. Inch and a-half and two inch stuff is bringing at least three dollars more than a year ago. Shingles are in large demand, all our mills running day and night, and prices firm. The impression is abroad, that a good many logs are hung up, and if they should remain in this shape, future prices would be influenced thereby. It is true, that this was the case the early part of the month, but there has been an active movement within the past two weeks, and a good many logs that were out of sight, so to speak, are now coming along nicely. We have heard of two or three specific instances, where as yet the hanging up condition holds control, but we have no reason to suppose, from the reports in our hands, at this writing, that this will be at all general.

Business in New Brunswick is experiencing a setback, as a result of a strike among the mill men. On 29th inst the mill-owners posted notices in the mills announcing that after July 13th 10 hours would constitute a day's work. On seeing these notices the men instantly struck, and that night held the largest labor meeting ever seen in St. John. The strike will paralyze the entire lumber business along the St. John river, except Gibson's and may seriously interfere with next season's logging operations. It will also strike a heavy blow at the schooners trading with American ports, which largely depend on lumber to make up their cargoes. Some 2,000 men are now idle, and all the mills are shut down with prospects of remaining so for the season.

UNITED STATES.

The labor strikes, especially in the eastern States, that threatened the trade a month ago, are not an active factor today, but the aftermath is there, and it is an illustration again of the aphorism, "strike but hear." To the extent that the strikes and boycotts of a month past had an existence, in that measure trade has been injured—and the strikers, along with all others, have been hit. Trade is better than it was a month ago, because the strike is off, but no great activity prevails.

A hand to mouth policy in buying is reported at the principal centres. A desire to make sales, but not many to be made. In Michigan we hear of a weakening in prices of several grades. From Saginaw comes the story that old time buyers are not showing up as they used to do, indicating that the markets are changing and that other points are being selected as centres of buying.

Maine dealers are realizing the influence of Canadian car trade. A report from Portland, Me. reads: "With the number of mills sawing, reinforced by the Canadians, who are becoming a large factor in the car trade, with the heavy stocks that are being thrown on the market from the east, the indications are that prices for some time will not be more than fair."

FOREIGN.

The Australian market is reported exceedingly dull, a circumstance that is having some effect on trade in British Columbia. The conditions of the English market are reported more favorable than they have been for some time past. The arrivals chronicled at the London docks for the week ending 13th inst are the heaviest of the season, but they do not come up to those generally reported at this advanced period. The first arrival from Quebec is reported, being the steamer Bede in the Surrey Commercial Docks, with a cargo of about 1,300 standards of pine. The hardwood market is somewhat quite.

Toronto, Ont.

TORONTO, June 30, 1891.

CAR OR CARGO LOTS.

Table listing lumber prices for Toronto, Ontario, including items like 1 & 1 1/2 in. cut up and better, 1x10 & 12 dressing and better, etc.

YARD QUOTATIONS.

Table listing yard quotations for Toronto, including mill cull boards & scantling, shipping cull boards, miscellaneous widths, etc.

Ottawa, Ont.

OTTAWA, June 30, 1891.

Table listing lumber prices for Ottawa, Ontario, including pine, 1st qual., 2nd, shipping culls, etc.

Montreal, Que.

MONTREAL, June 30, 1891.

Table listing lumber prices for Montreal, Quebec, including pine, 1st quality, 2nd, shipping culls, etc.

Oswego, N. Y.

OSWEGO, June 30, 1891.

Table listing lumber prices for Oswego, New York, including three uppers, pickings, etc.

Siding.

Table listing siding prices for Oswego, including 1 in siding, cutting up, etc.

1x12 Inch.

Table listing 1x12 inch lumber prices for Oswego, including 12 & 16 ft. mill run, etc.

1x10 Inch.

Table listing 1x10 inch lumber prices for Oswego, including 12 & 13 ft. mill run, etc.

1x8 Inch.

Table listing 1x8 inch lumber prices for Oswego, including 12 & 13 ft. mill run, etc.

Shingles.

Table listing shingle prices for Oswego, including XXX, 18 in pine, etc.

Pickets.

Table listing picket prices for Oswego, including No. 1, 1 1/2 x 1 1/2, etc.

Lath.

Table listing lath prices for Oswego, including No. 1, 1/2, etc.

St. John, N. B.

ST. JOHN, June 30 1891.

Deals, Boards, Scantling, etc.

Table listing lumber prices for St. John, New Brunswick, including spruce deals, pine, deal ends, etc.

Shingles.

Table listing shingle prices for St. John, including spruce, extra, clear, etc.

Clapboards.

Table listing clapboard prices for St. John, including pine, extra, clear, etc.

Flooring, Dressed.

Table listing flooring prices for St. John, including 6 in. No. 1, No. 2, etc.

Miscellaneous.

Table listing miscellaneous lumber prices for St. John, including staves, heading, etc.

Albany, N. Y.

ALBANY, N. Y., June 30, 1891.

Hemlock.

Table listing hemlock prices for Albany, including boards, joist, etc.

Pine.

Table listing pine prices for Albany, including 2 1/2 in. and up, good, etc.

Table listing pine prices for Albany, including 1 1/2 to 2 in., good, etc.

Table listing pine prices for Albany, including 1 in. good, etc.

Table listing pine prices for Albany, including 4ths, etc.

Table listing pine prices for Albany, including 1 1/2 to 2 in., good, etc.

Table listing pine prices for Albany, including 4ths, etc.

Table listing pine prices for Albany, including 1 1/2 to 2 in., good, etc.

Table listing pine prices for Albany, including 4ths, etc.

Table listing pine prices for Albany, including 1 1/2 to 2 in., good, etc.

Table listing pine prices for Albany, including 4ths, etc.

Table listing pine prices for Albany, including 1 1/2 to 2 in., good, etc.

Table listing pine prices for Albany, including 4ths, etc.

Table listing pine prices for Albany, including 1 1/2 to 2 in., good, etc.

Table listing pine prices for Albany, including 4ths, etc.

Table listing pine prices for Albany, including 1 1/2 to 2 in., good, etc.

Table listing pine prices for Albany, including 4ths, etc.

Table listing pine prices for Albany, including 1 1/2 to 2 in., good, etc.

Table listing pine prices for Albany, including 4ths, etc.

Table listing pine prices for Albany, including 1 1/2 to 2 in., good, etc.

Table listing pine prices for Albany, including 4ths, etc.

Table listing pine prices for Albany, including 1 1/2 to 2 in., good, etc.

Table listing pine prices for Albany, including 4ths, etc.

Table listing pine prices for Albany, including 1 1/2 to 2 in., good, etc.

Table listing pine prices for Albany, including 4ths, etc.

Table listing pine prices for Albany, including 1 1/2 to 2 in., good, etc.

Table listing pine prices for Albany, including 4ths, etc.

Table listing pine prices for Albany, including 1 1/2 to 2 in., good, etc.

Table listing pine prices for Albany, including 4ths, etc.

Table listing pine prices for Albany, including 1 1/2 to 2 in., good, etc.

Table listing pine prices for Albany, including 4ths, etc.

Table listing pine prices for Albany, including 1 1/2 to 2 in., good, etc.

Table listing pine prices for Albany, including 4ths, etc.

Buffalo and Tonawanda, N. Y.

RUFFALO, June 30, 1891.

Norway.

Table listing Norway lumber prices for Buffalo, including clear, 1 in. & clear, etc.

White Pine.

Table listing white pine prices for Buffalo, including up's, 1 & 1 1/2 in., etc.

Table listing white pine prices for Buffalo, including 1 1/2 to 2 in., etc.

Table listing white pine prices for Buffalo, including 1 1/2 to 2 in., etc.

Table listing white pine prices for Buffalo, including 1 1/2 to 2 in., etc.

Table listing white pine prices for Buffalo, including 1 1/2 to 2 in., etc.

Table listing white pine prices for Buffalo, including 1 1/2 to 2 in., etc.

Table listing white pine prices for Buffalo, including 1 1/2 to 2 in., etc.

Table listing white pine prices for Buffalo, including 1 1/2 to 2 in., etc.

Table listing white pine prices for Buffalo, including 1 1/2 to 2 in., etc.

Table listing white pine prices for Buffalo, including 1 1/2 to 2 in., etc.

Table listing white pine prices for Buffalo, including 1 1/2 to 2 in., etc.

Table listing white pine prices for Buffalo, including 1 1/2 to 2 in., etc.

Table listing white pine prices for Buffalo, including 1 1/2 to 2 in., etc.

Table listing white pine prices for Buffalo, including 1 1/2 to 2 in., etc.

Table listing white pine prices for Buffalo, including 1 1/2 to 2 in., etc.

Table listing white pine prices for Buffalo, including 1 1/2 to 2 in., etc.

Table listing white pine prices for Buffalo, including 1 1/2 to 2 in., etc.

Table listing white pine prices for Buffalo, including 1 1/2 to 2 in., etc.

Table listing white pine prices for Buffalo, including 1 1/2 to 2 in., etc.

Table listing white pine prices for Buffalo, including 1 1/2 to 2 in., etc.

Table listing white pine prices for Buffalo, including 1 1/2 to 2 in., etc.

Boston, Mass.

BOSTON, June 30, 1891.

Western Pine—by car load.

Table listing western pine prices for Boston, including uppers, 1 in, etc.

Table listing western pine prices for Boston, including 1 1/2 & 2 in, etc.

Table listing western pine prices for Boston, including 1 1/2 & 2 in, etc.

Table listing western pine prices for Boston, including 1 1/2 & 2 in, etc.

Table listing western pine prices for Boston, including 1 1/2 & 2 in, etc.

Table listing western pine prices for Boston, including 1 1/2 & 2 in, etc.

Table listing western pine prices for Boston, including 1 1/2 & 2 in, etc.

Table listing western pine prices for Boston, including 1 1/2 & 2 in, etc.

Table listing western pine prices for Boston, including 1 1/2 & 2 in, etc.

Table listing western pine prices for Boston, including 1 1/2 & 2 in, etc.

Table listing western pine prices for Boston, including 1 1/2 & 2 in, etc.

Table listing western pine prices for Boston, including 1 1/2 & 2 in, etc.

Eastern Pine—Cargo or Car Load.

Table listing eastern pine prices for Boston, including Nos. 1, 2 & 3, etc.

Table listing eastern pine prices for Boston, including Nos. 1, 2 & 3, etc.

Table listing eastern pine prices for Boston, including Nos. 1, 2 & 3, etc.

Table listing eastern pine prices for Boston, including Nos. 1, 2 & 3, etc.

Table listing eastern pine prices for Boston, including Nos. 1, 2 & 3, etc.

Table listing eastern pine prices for Boston, including Nos. 1, 2 & 3, etc.

Table listing eastern pine prices for Boston, including Nos. 1, 2 & 3, etc.

Table listing eastern pine prices for Boston, including Nos. 1, 2 & 3, etc.

Lath.

Table listing lath prices for Boston, including spruce by cargo, etc.

Shingles.

Table listing shingle prices for Boston, including spruce, cedar, etc.

**THE LUMBER TRADE.**

**Opinions of Two Leading Bank Managers.**

IN HIS annual address, to which editorial reference is made elsewhere in these columns, Mr. Geo. Hague, general manager of the Merchants Bank of Canada, said:

The great timber manufacture of the Ottawa Valley that finally centres in Quebec met with a serious reverse last year. Overproduction flooded the English market, and such a serious drop in prices ensued as to cause heavy losses to exporters. We had in this department of trade some striking illustrations of the evil referred to, namely, of parties with only moderate capital engaging in enterprises far beyond their means and being completely ruined in consequence. Our own share of loss in this quarter has, however, been very moderate. This trade is gradually recovering itself through a heavy decrease in production.

The sawn lumber trade with the United States has proceeded with much more regularity and there is every prospect of a good demand for another season. The markets of the States are not overloaded, and there is no reason why a good season's trade may not be expected. The great question of the conservation of our forests has not come to the front very prominently as yet, but it must receive attention before long. The question of how to make the best use of the trees of every description, large or small, that are growing in the woods, is being solved in a practical manner by a firm in Ontario. It could hardly be supposed that articles so diverse as lumber, paper, terra cotta and alcohol could be produced from our trees, but such is the fact. The development of our various paper-making factories, the raw material for which is largely obtained from our forests is proceeding steadily year by year. These are only examples of the various new and undreamed of uses to which our forests can be turned; and doubtless as experiments are tried, new developments will await us.

Mr. B. E. Walker, general manager of the Bank of Commerce, the largest banking institution in the Province and second in the Dominion, said:

The trade in square timber, in which, as I said a year ago, we have little or no interest, is not yet in a healthy condition. There is still in sight more timber than the total product of any year since 1881, although the amount made in the past year is only about one-fifth of that for 1889-90. It is therefore to be hoped that next winter the quantity manufactured will be as nearly nothing as may be possible. The work in the woods has been done under favorable circumstances and the output is correspondingly cheaper than in recent years; part of the reduction in cost, however, is unfortunately the result of lower wages. Since the maximum cut of logs cut in the Ottawa district, in 1887-8, the stock in hand has been steadily falling, we are glad to notice, and is now lower than on any but two of the last ten years. The demand in the United States is satisfactory, at prices higher than a year ago, but the South American market is still wanting. As we have said in past years, a diminished production is all that is necessary to give the lumber business a quite satisfactory tone, and at the moment the Ottawa manufacturers have fair profits in prospect. The output in the North Shore district is also smaller, but the general conditions of the business are not as favorable as could be desired. The home market, on which they largely depend, is very limited, owing to the collapse in real estate speculation and the general shrinkage in business.

AN AMERICAN contemporary referring to the extensive mills of Mr. J. R. Booth on the Chaudiere, says: "We believe at no milling point on the American continent outside of Canada has any mill man stamped the boards which came from his saws. When a mill man does that it is very evident that in his opinion the lumber is manufactured in A1 style." And this, of course, is the reason why our American friends are constantly in quest of Canadian lumber.

**CHIPS AND BARK.**

It is a wise old saw, that knows its own broken teeth.

A tree leaves every spring, but does not take its trunk along.

Brokers are kind-hearted people. When they find a man who isn't in it they take him in.

So far as lumber manufacture is concerned, the band saw may be said to be in it.

"Patti's voice must be of wonderful timbre, don't you think so?" Van Pelt? "Yes. Judging by the price of tickets it must be sandal-wood."

Popularly speaking, when a man is "up a tree" he is supposed to have an advantage of some sort, but when he is "up a stump" it is quite a different thing.

California has 2,675 of the giant trees still left, and the largest of these is thirty-three feet in diameter. They ought all to be preserved and kept in a public park.

Never judge a man by his appearances. A shabby coat may contain an editor, while the man wearing a high-toned plug hat and supporting a dude cane may be one of his delinquent subscribers.

Scotland imports timber to the value of \$15,000,000 annually and at the same time has 7,500,000 acres of waste land well suited for tree cultivation. That so thrifty a people as the Scotch should permit such a state of things is rather peculiar.

"The greatest piece of luck I ever had," said Peter Cooper, "was investing the first surplus money I earned in a lottery ticket. I lost, but I gained this experience: that the wheel of fortune is only turned by common sense applied to common events."

A negro who stopped work on a Georgia railroad gave the following reason: "Well, you see de Macon Destruction Comp'ny busted and de road is bin put in de hands of a deceiver, so I jus quit." That darkey was wiser than he knew.

One of the most important questions the logger asks himself at this season of the year when water may be a valuable article, is, "Are my dams all right?" If not all right he is liable to make twin dams right on the spot.

It is said that Samson was a liberal advertiser. He took two solid columns to demonstrate his strength, and several thousand people "tumbled" to the scheme at once. In fact he brought down the house.

The simple machine, with rope and block and tackle equipment, used for hoisting by stone-masons and other builders, and known as the "derrick" got its name from a renowned hangman in England, in the seventeenth Century, named Derrick, who invented it for erecting gibbets for executions by hanging.

Price cutting is a thing that is continually deprecated and pronounced against, yet it crops out everywhere and in every line of trade. There seems to be some kind of microbe in the business that breeds low prices in spite of all the preventives that can be employed. The claim that a dealer is being undersold generally acts upon his feelings like a red flag flaunted in the face of a belligerent bull.

Read this, ye ordinary snake-story liars, then hide your diminished heads in shame: While a large pine log was being sawed into lumber at Brown & Hall's saw mill near Acton, Ont., after the outside slab and one board had been cut off, and while the workmen were turning over the log preparatory to "squaring" it, they were surprised to see a large toad poke his head out of a hole, where he was embedded, and where he had barely escaped being cut up by the saw. As the log was the fourth or fifth up from the butt of the tree, his position must have been at least 50 or 60 feet from the ground. There is but one way of accounting for the fact that he was found in the position named. He had grown up with the tree from infancy, and was probably hundreds of years old when the saw awoke him from his long nap.

The wood-pile is a farm factor of great importance, and whoever neglects it quarrels with his dinner, and may be compelled to contend with hunger. Some farmers may burn coal but generally the fuel is wood, in spite of the cry of the alarmists who declare the forests are receding and soon will disappear. The wood pile may serve as a sign, and make a good method of the farmer. If the pile be big in the morning, then it is known that the owner does not intend to be disturbed in the busy season, about ten o'clock in the morning, by the cry from the house, "If you want any dinner, you must cut some wood." If there be only a chopping-block and a few uncut sticks lying around, then it is evident that the house keeper, in addition to other cares, must worry about the fuel supply.

A new use has been discovered for the circular saw. Every lumberman is familiar with the music which that useful saw mill accessory produces when it is in successful operation on a log, and to many its energetic and permeating sound has much of melody. But it remained for a charivari party in the town of Sullivan, Mich., to develop the full extent of musical capabilities that the circular saw possesses. These they brought out on the occasion named so successfully that the charivari groom brought suit against them for damages. In his complaint the groom, Mr. Warren Atkins, sets forth that both himself and wife are perfectly willing to condone the use of tin pans and boilers as musical instruments, and that they are even content to excuse the filling of the domestic stove-pipe with the fell purpose of smoking them out; but they draw the line at circular saws. Therefore they ask the court to assess damages against the leaders of the charivari party to the amount of \$5,000.

**LUXURY AT SEA.**

A skip o'er the ocean wave,  
A plunge through the bounding deep,  
While the sweat my temples lave  
And my bowls their revels keep.  
My mouth is full of brine,  
My hair is turning gray,  
The chills creep up my spine—  
O-o o-o h, alas! and alack a day!  
Lord, kindly still this sea,  
And its everlasting roar!  
If I ever get back to the old saw mill  
I'll ne'er go sailing more.

Look on your wrapper; it tells when your subscription expires.

THE LUMBERMAN is one of the best trade papers published in Canada.—*British Columbia Commercial Journal.*

DURING the month of May of this year the exports of forest products from the Dominion of Canada fell off \$2,000,000 in value compared with the similar month of last year.

A Washington lumber company recently received an order from Australia that calls for 20,000,000 feet of lumber. Twenty-five large ships will be required for its transportation.

THE revenue derived from the woods, forests and lands belonging to the British crown amounts to over \$2,500,000 annually. When Queen Victoria came to the throne she exchanged these revenues for a yearly sum of \$1,925,000.

"Courie May," is the name given to a new steamer constructed this season for Angus Fraser, of Comox, B.C. She is 62 feet long, by 15 feet beam, and it is said can make 13 knots an hour.

**J. J. TURNER,**  
**Sail, Tent and Awning Maker.**  
251 GEORGE AND 154 KING STREETS,  
PETERBOROUGH.  
Canoe, Yacht and Boat Sails made to order.  
Perfect Fits guaranteed  
Every description of Lumbermen's Subtles  
and Waterproof Clothing.

**WILLIAM FOSTER**  
**Lumber & Commission Merchant**  
Receiver and forwarder of  
**LUMBER, LATH & SHINGLES**  
Correspondence Solicited.  
**OWEN SOUND, ONT.**

**J. D. SHIER,**  
Manufacturer of  
**Lumber, Lath and Shingles**  
**BRACEBRIDGE, ONT.**

**T. SHORTISS,**  
DEALER IN  
**PINE & MINERAL LANDS**  
9 Toronto Street,  
**TORONTO, ONT.**  
CORRESPONDENCE SOLICITED.

PATENTED 5TH MARCH, 1877.  
**PARKER & EVANS,**  
Sole Proprietors of the  
**FAMOUS INTERNATIONAL**  
**BOILER - FLUID - COMPOUND.**  
This compound will save its cost many times in one year by saving fuel.  
It eradicates scale, and when the Boiler is once Clean a very small quantity keeps it clean and free from all incrustation. One fourth the dose will prevent a new Boiler from scaling so long as it is used regularly.  
Contains no Caustic Soda, and is the only matter yet known that will not injure metals in any way, and emits a clear pure steam.  
**30 WILLIAM STREET, - MONTREAL.**

# HEAVY SAWMILL MACHINERY

## NO. 4 SAW FRAME

With Top Saw Attachment.

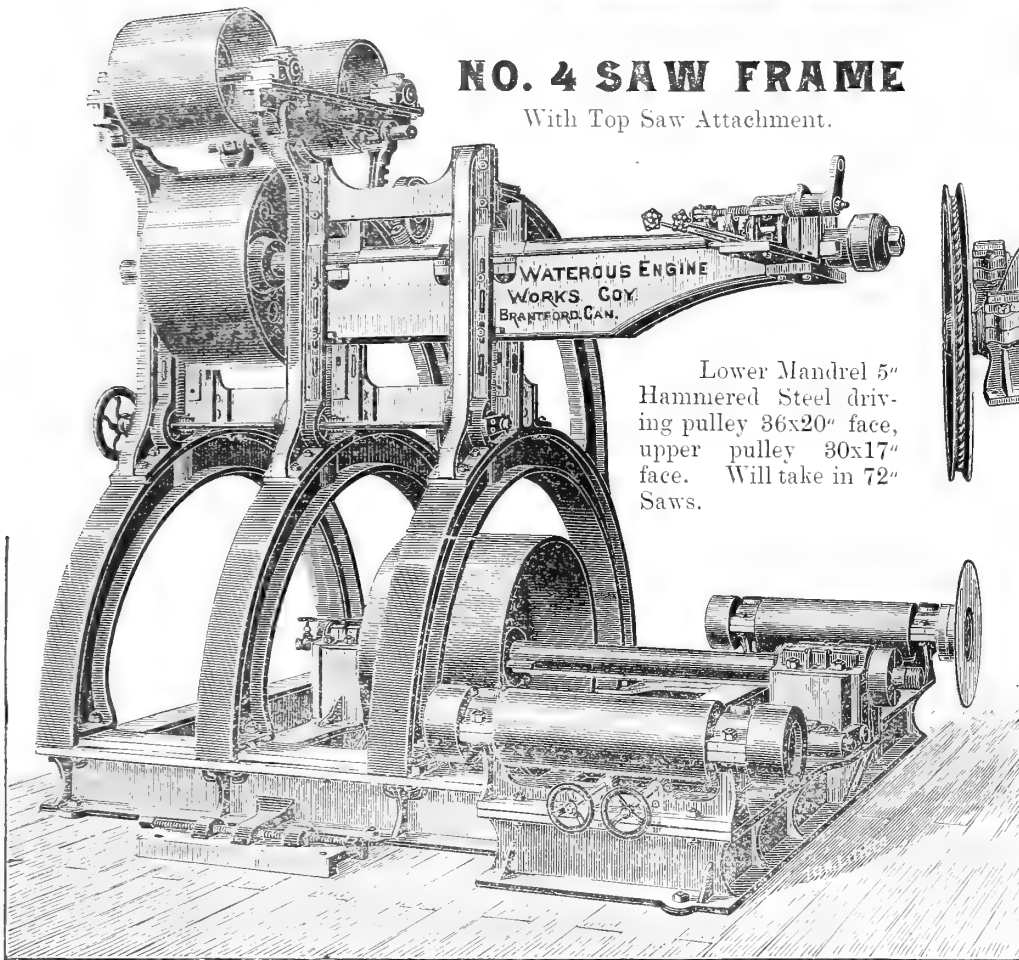

Lower Mandrel 5" Hammered Steel driving pulley 36x20" face, upper pulley 30x17" face. Will take in 72" Saws.

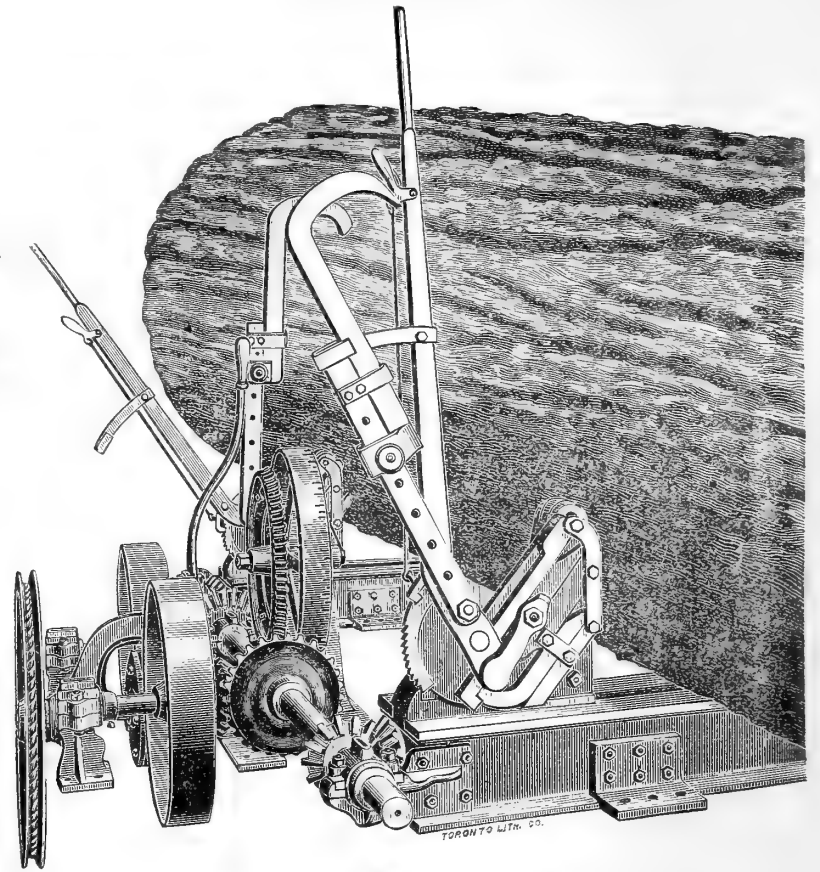

## No. 6 Steel Log Carriage

Made of Wrought and Cast Steel throughout.

SHORT HEAVY KNEES, with roller at top, moved with heavy steel screws.

SET WORKS are our improved power set, actuated by steel cable and intirely under the control of the setter.

LOGSEATS open any distance from saw desired. Carriages made any length.

**FEED** ; Carriage is driven by our Oscillating Engines, with 14 x 20 cylinders, making an exceedingly strong and uniform feed.

## Champion Gang Edger.

The wide Cants 50 to 60 inches wide, 6 to 9 inches thick, are dropped on rollers and run through the 6 saw Champion Edger, using 6 Hoe bit tooth saws, ripping them into all sizes of dimension timber.

The 4 machines described above, with 6 blocks in the carriage, will weigh in the vicinity of 35 tons.

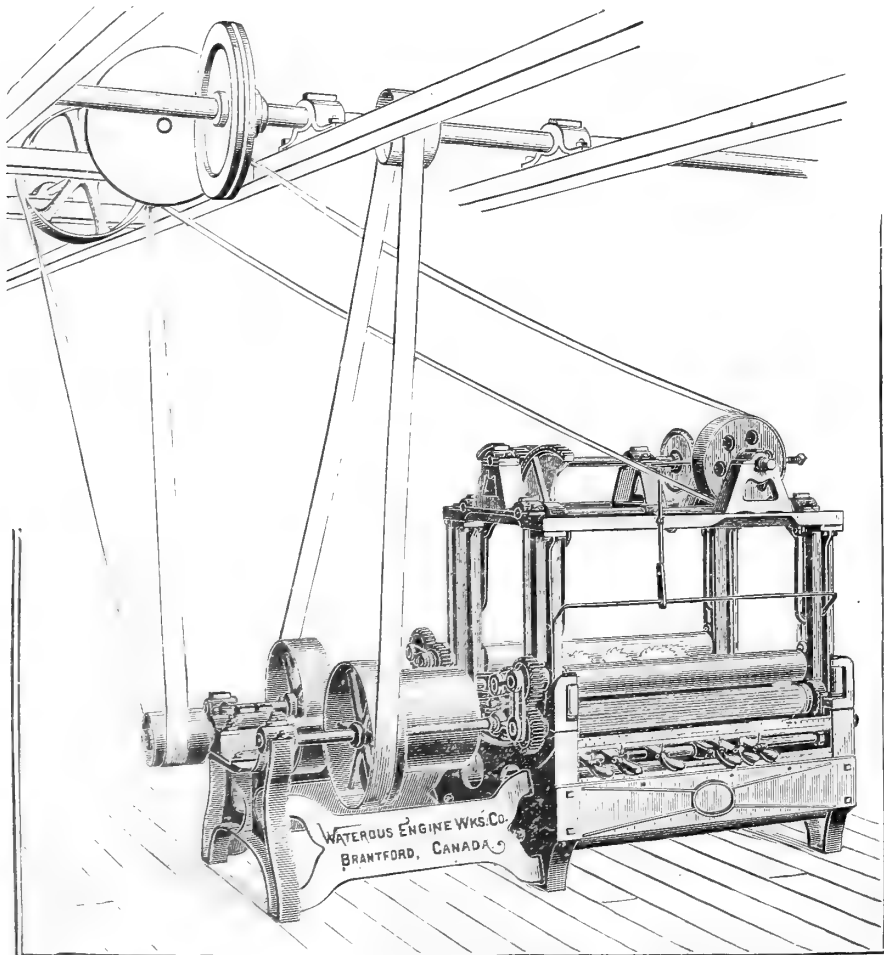
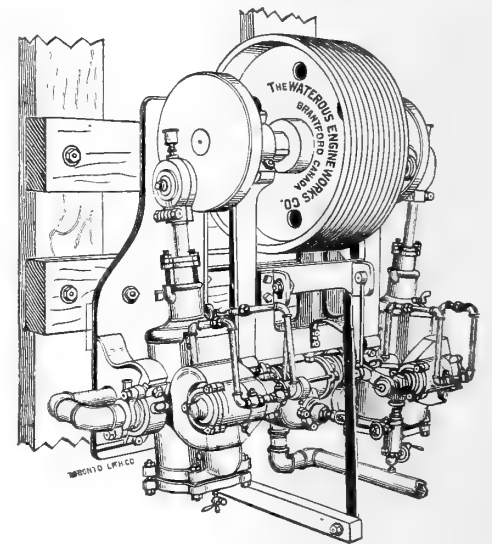

Send for Circulars and Estimates on full Sawmill Plants.

*Waterous Engine Works Co.,  
BRANTFORD, CAN.*



**WANTED AND FOR SALE.**

Advertisements will be inserted in this department at the rate of 15 cents per line each insertion. When four or more consecutive insertions are ordered a discount of 25 per cent. will be allowed. This notice shows the width of the line, and is set in Nonpareil type. Advertisements must be received not later than the 27th of each month to insure insertion in the following issue.

**PLANING MILL FOR SALE.**

THE undersigned offer their Planing Mill for sale, with or without the wood working machinery. Price and terms on application. Address, JNO. WOOD & SONS., Cor. Front and Erin streets, Toronto.

**For Sale or Will Exchange for Saw Mill Machinery.**

REAL ESTATE, valued at \$1,400. The above property consists of lots 1 and 2 Havelock street, in the village of Oxenden, on which there is a large two storey dwelling house and store, with large cellar, good cistern, fresh water pumps and every convenience; besides store house, stables, sheds, and good plum orchard, bearing. Address, W. J. MALLARD, Oxenden, Ontario.

**WANTED—TO BUY.**

GOOD Canadian Timber Limits and Georgian Bay saw logs. Address, BEN BIRDSALL, Whitney Building, Detroit, Mich.

**WANTED.**

EMPLOYMENT or partnership in lumber business, by man of large experience in manufacturing and shipping. Ready by 15th May. High references. Address, R. B. CANADA LUMBERMAN, Toronto.

HARDWOOD lumber, bought, sold or received on consignment, TUCKER DAVID, lumber commission merchant, 202 Eleventh Ave., N.Y.

**WANTED IN 1891.**

ANY QUANTITY OF CEDAR TELEGRAPH POLES at shipping points. Terms cash. Apply to J. HARRISON HARVEY, Cobocok, Ont., purchaser for H. D. McCAFFREY, Engineer and Contractor of Telegraph lines, Oswego, N.Y.

**RAILS AND CARS FOR SALE.**

Light Steel Rails for Tramways; good order. Cars for lumber, cheap. JOHN T. GARTSHORE, 49 Front St. West, Toronto.

**WANTED.**

QUEBEC BIRCH—Those who can furnish choice lumber are invited to correspond with JOHN S. MASON & CO., 240 Eleventh Avenue, New York City.

**Timber Limits**

BRITISH COLUMBIA.

**FOR SALE!**

\$5,000 to \$50,000 of shares in a Stock Company owning and operating Saw and Planing Mills Sash and Door Factory, etc. Valuable Timber Limits in connection. This is an exceptionally good chance to make money.

Address—LIMITS, Care of CANADA LUMBERMAN, Toronto.

E. F. Ames & Co.

Lumber Commission Correspondence solicited from Canadian manufacturers.

Room 3, Lumber Exchange, Chicago, Ill.

**FOR SALE.**

**ENGINES, \* BOILERS, STEAM PUMPS, ETC.**

- One Twin Steam Engine. 21 inch cylinder, 36 inch stroke.
- One Twin Steam Engine. 14 inch cylinder, 20 inch stroke.
- One Single Steam Engine. 14 inch cylinder, 20 inch stroke.
- Nine Double Flue Boilers. 26 feet by 54 inches in diameter.
- Six Tubular Boilers. 16 feet by 48 inches in diameter.
- Two Locomotive Engines.

Suitable for lumber yards or mines. Engines and Boilers are at present in position, having all necessary connections, and are in first class condition having been but a short time in use.

One Large Silsby Steam Pump with Boiler.

Capable of raising steam in seven minutes.

Two Steam Pumps.

Cylinders 12 inches and 5 inches.

One Water Space Refuse Burner.

For particulars Apply to

**LAW BROS. & CO.,**  
OTTAWA, ONT.



**THE ONTARIO CULLERS' ACT.**

NOTICE is hereby given that it is intended to hold an examination of candidates desiring to be licensed as cullers at each of the undermentioned places and dates, and that the places and dates of which notice was formerly given, have been cancelled.

Ottawa, Sudbury, Peterborough, Belleville, Bracebridge, Parry Sound, Arnprior, and Rat Portage, on Wednesday, 15th July, at 10 o'clock a.m.

Sault Ste. Marie and Port Arthur, on Monday, 20th July, at 10 o'clock a.m.

Spanish River Mills, on Friday, 17th July, at 10 a.m.

Candidates will have to make a written application and pay the fee of four dollars on or before the day of examination. AUBREY WHITE,

Asst. Commissioner, Department of Crown Lands, Woods and Forests Branch, Toronto, 5th June 1891.

No unauthorized advertisement of the above will be paid for.

**A. T. ANDERSON & CO.,**

CONTRACTORS FOR

**ELECTRICAL AND GENERAL MACHINERY.**

Complete installations of steam and Hydraulic Power, Electric Light and Power Plants, Wiring and Construction for Arc and Incandescent Lighting. Agents for the celebrated "C. & C." Electric Motors.

75 Adelaide Street East, Toronto, Ont., Canada.

Estimates furnished and every information cheerfully given to intending purchasers. N. B.—Only first-class work on which a full guarantee will be given.

**ROCHESTER BROS.**

**Commission Agents.**

Limits bought and sold on commission. Limits travelled and carefully prepared estimates given. Some first-class berths on the north shore of Lake Huron and on the Upper Ottawa now in our hands for sale. Communications confidential. References given.

36 ROCHESTER ST., OTTAWA.

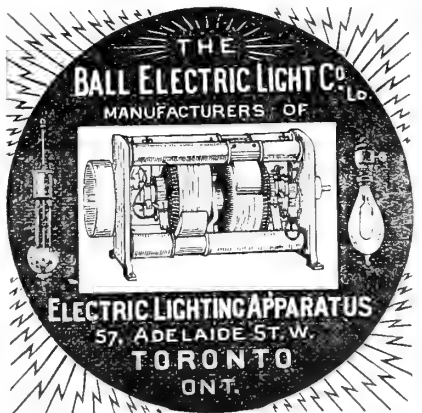

**Ontario Mining Laws.**

The following are a summary of the provisions of the amendments to the Mining Law of Ontario, passed during the session of 1891.

1. In Algoma, Thunder Bay, Rainy River at that part of Nipissing north of Lake Nipissing at the French and Mattawa Rivers, the price per acre of mining lands sold after the 4th day of May, 1891, is \$4.50 in a surveyed township and \$4 in unsurveyed territory if within 12 miles of a railway and if beyond that limit \$3.50 in surveyed and \$3 in unsurveyed territory. If the land is sold within 12 miles of a railway and \$2 per acre at a greater distance.

2. Instead of by grant, the right to mine may be obtained by purchase of a ten-year lease of a per acre rental, unless otherwise provided by regulation, of \$1 for the first year and 25 cents per acre thereafter after the 4th day of May, 1891, and the French and Mattawa Rivers, or of 50 cents per acre per year and 15 cents per acre thereafter, where, with right of renewal at ten-year intervals, an additional ten years at the same rental, and with a right of renewal thereafter every twenty years, subject to payment of the yearly rental charge in advance and to such conditions as may be provided by regulation. But the lessee may at any time purchase the land so held, in which case the first year's rent shall be treated as part of the purchase money.

3. The owner or lessee of mining lands sold or leased by the Crown after the 4th day of May, 1891, is required during the first seven years to expend in actual mining operations \$1 per acre if the location exceeds 160 acres, and \$5 per acre if less than 160 acres or less.

4. After the 4th day of May, 1891, all ores or minerals of silver, nickel or nickel and copper taken from lands sold or leased by the Crown, are subject to a royalty of 3 per cent., and all other ores or minerals to such royalties as shall from time to time be fixed by order in council, not exceeding in the case of iron 2 per cent., and as to any other ores or minerals not exceeding 3 per cent.; and such royalties shall be calculated upon the value of the ores at the pit's mouth. But royalties shall not be imposed or collected upon any ores until after seven years from date of the patent or lease, except as to mines known to be rich in nickel, and as to these not until after four years.

5. Hereafter in all lands sold under the Public Lands Act, or for agricultural purposes, all minerals and mining rights are reserved to the Crown, unless otherwise provided in the patent or grant.

6. In the case of mining lands for which bonafide application was made in writing to the Department prior to the 24th of April, 1891, grants may be made where the application is received within three months from the 4th day of May, 1891, and otherwise at the price and upon the conditions heretofore applicable in accordance with the terms of section 1, subsection 5, of the act of 1891.

ARCHIBALD BLUE, Director.

OFFICE OF THE BUREAU OF MINES, TORONTO, May 21, 1891.

This advertisement will not be paid for if published without authority.



- Cant Dogs, Peavies,
- Skidding Tongs,
- Pike Poles, Coldshuts,
- \* Lumber Bob Sleighs. \*

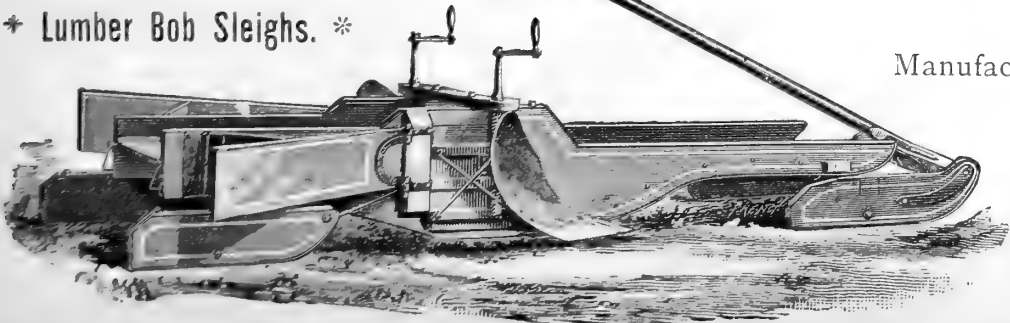

**J. Muckleston & Co.**

Kingston, Ont.

Manufacturers of RED TOP LINE

**LUMBERMEN'S \* TOOLS.**

And Sole Licences for the Manufacture in the Dominion of

**BRAZEL'S PAT. SNOW AND SIDEWALK PLOWS.**

# The Only Successful Kiln for Drying Oak and other Hardwoods

**"THE ANDREWS"**

NEW LUMBER

## DRY-KILN

Remarkable efficiency depends upon its peculiar mode of applying heat to, and eliminating moisture from, the air used in drying. We use no costly fan, engine or other device that requires constant attention, nor do we waste heat by a special chimney. The air circulates through the lumber, and the moisture absorbed from it is extracted from the air by natural methods. You can not afford to be without it.

Our Process Duplicates Nature.

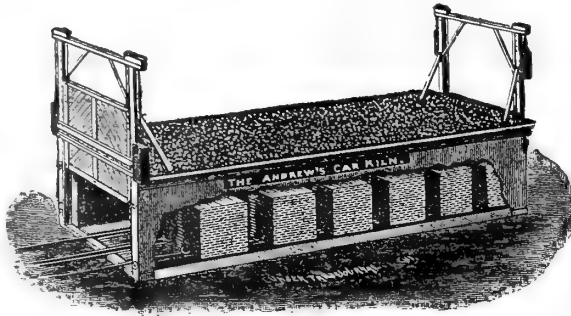

Outside View of the Andrews Kiln.

The following well-known furniture manufacturers have recently purchased the "ANDREWS KILN."

- Estey Manufacturing Co., - - - Owasa, Mich.
- East Shore Furniture Co., - - - Manistee, Mich.
- Universal Tripod Co., - - - Grand Rapids, Mich.
- Grand Rapids School Furniture Co., Grand Rapids, M.
- New England Furniture Co., - Grand Rapids, Mich.
- Milwaukee Chair Co., - - - Milwaukee, Wis.
- Oshkosh Furniture Co., - - - Oshkosh, Wis.
- Skandia Furniture Co., - - - Rockford, Ill.
- Story & Clark Organ Co., - - - Chicago, Ill.
- Rock Falls Manufacturing Co., - - - Sterling, Ill.
- Courey & Birely Table Co., - - - Shelbyville, Ind.
- Southern Spring Bed Co., - - - Atlanta, Ga.
- Sidney School Furniture Co., - - - Sidney, Ohio.
- New Richmond Church Furniture Co., N. Richmond, O.

### A. N. Andrews & Co., Proprietors and Manufacturers

15, 217, 219, 221 Wabash Ave., CHICAGO, ILL.

## The Casselman Lumber Co.

CASSELMAN, ONT. Successors to FLATT & BRADLEY.

ESPECIAL GOOD FACILITIES FOR SHIPPING.  
HEMLOCK BILL STUFF OF EXCELLENT QUALITY.  
ALSO MANUFACTURERS OF  
PINE, SPRUCE, ASH, MAPLE AND OTHER HARDWOODS.  
CORRESPONDENCE SOLICITED.

CEO. HASTINGS. JOHN GRAY. H. HANCOCK.

## GEO. HASTINGS & CO.

Lumber Merchants

TRUST BUILDING CHAMBERS,  
Cor. Yonge and Colborne Streets. TORONTO.

All Kinds of Pine and Hardwood Lumber.

BILL STUFF CUT TO ORDER A SPECIALTY.

J. W. MAITLAND  
H. RIXON

J. G. AINSLIE  
W. STODART

## Maitland, Rixon & Co.,

Owen Sound, Ont.

### Saw Millers & Lumber Dealers

All kinds of Building Material kept in stock.

WE MAKE A SPECIALTY OF  
LONG BILL STUFF IN ROCK ELM, PINE, CEDAR AND HEMLOCK  
QUOTATIONS FURNISHED ON APPLICATION.

## DONOGH & OLIVER,

Wholesale Dealers in

# LUMBER

OFFICE:

Nos. 213, 214 and 215, Board of Trade Building,

COR. YONGE AND FRONT STS.

TORONTO, ONT.

## THE "LEADER"

The Finest Tempered, Fastest Cutting and Best Saw made on the Continent.



Manufactured of Triple Refined Silver Steel, Rolled specially for us from Superior Ingots.

### THE KING OF CROSS-CUT SAWS

## R. H. SMITH COMPANY, LTD., ST. CATARINES, ONT.

Sole Manufacturers.

# Friction Pulley Board.

The Best Materials ever used  
for Frictions of all  
\* kinds \*

MANUFACTURED BY

Asbestos  
Mill  
Board.

The **DOMINION LEATHER BOARD COMPANY,**  
Montreal, Quebec.

Steam  
Packing.

SAMPLES FURNISHED.

PLEASE MENTION THIS PAPER.

CORRESPONDENCE SOLICITED.

# PULLEYS

*LIGHTEST,*  
*CHEAPEST,*  
*AND*  
*STRONGEST*  
*PULLEY MADE.*



*Best Shaft Fastening,*  
*Best Belt Surface,*  
*Best Looking*  
*PULLEY MADE*

20,000 now in use in Canada.

Send for Illustrated Catalogue and Price List.

# DODGE WOOD SPLIT PULLEY CO.

FACTORY:  
TORONTO JUNCTION.

TORONTO.

OFFICES:  
83 KING ST. WEST.

## THE STURTEVANT PATENT PROGRESSIVE LUMBER DRY-KILN.

DRIES HARD AND SOFT WOOD LUMBER WITHOUT WARPING, CHECKING OR BLUING.

The Sturtevant  
System of  
**Heating**  
MILLS  
and **FACTORIES**

BOSTON,  
34 OLIVER STREET.  
NEW YORK,  
91 LIBERTY STREET.

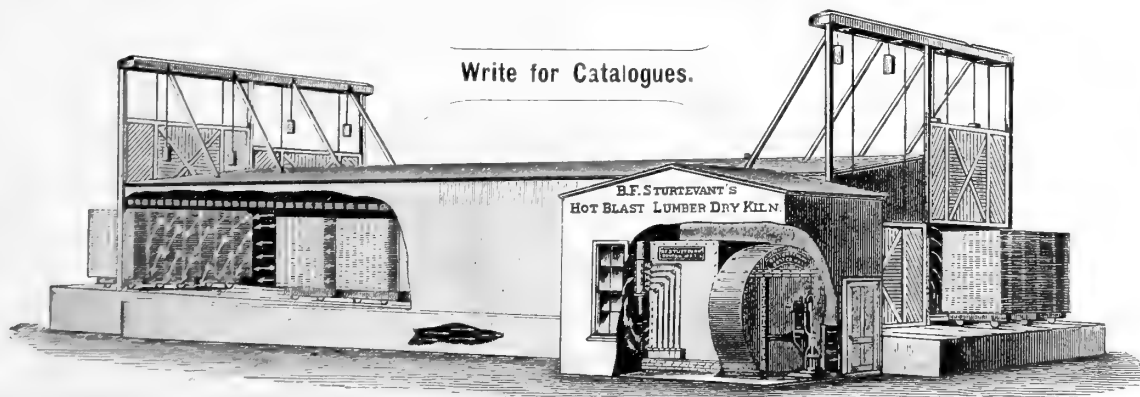

Write for Catalogues.

Steel Plate Plan-  
ing Mill  
**Exhausters**  
For Removing  
Chips, Shavings and  
Sawdust.

CHICAGO,  
16 South Canal Street.  
PHILADELPHIA,  
135 North Third Street.

**B. F. STURTEVANT CO., BOSTON, MASS., U.S.A.**

**A. R. WILLIAMS, Soho Machine Works, Toronto.**  
GENERAL AGENT FOR THE DOMINION.



Repairing

Promptly and

Carefully

Executed

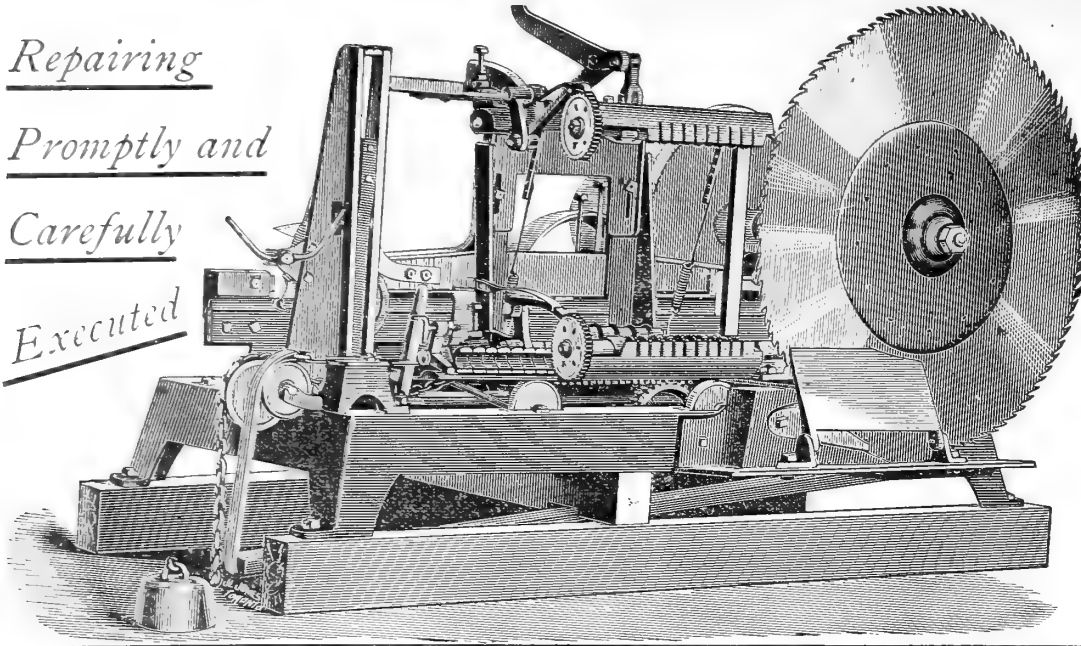

**B. R. MOWRY & SON**

MANUFACTURERS OF

**Saw Mill  
and Shingle Mill  
Machinery.**

*Shingle Machinery a Specialty.*

**The "BOSS" SHINGLE MACHINE**

Manufactured by us is acknowledged by practical men to be the best machine in the market.

**GRAVENHURST, ONT.**

The Gold Medal,  
Toronto, 1883

# WOOD WORKING MACHINERY

The Gold Medal,  
London, 1883

**For Door, Sash, Blind and Furniture Factories**

PLANERS.

MOULDERS.

TENONERS.

SHAPERS.

RIP SAWS.

SAND PAPERERS.

BAND SAWS.

BAND RE-SAWS.

PANEL RAISERS.

DOVETAILERS.

JOINTERS.

DOUBLE SPINDLE BORER.

BUZZ PLANERS.

MORTICERS.

BLIND MACHINERY.

BAND SAW FILER.

BAND SAW SETTER.

ETC., ETC.

## The Galt Bros. Co., Limited,

**GALT, ONTARIO.**

Write for Circulars  
and Prices.

Correspondence  
Solicited.

Established 1849.

Incorporated 1884.



# Detroit Saw Works

MANUFACTURERS OF

**Circular, Gang, Mulay, Drag and Cross-Cut Saws.**

**MOLDING AND PLANING KNIVES,**

We use nothing but W. J. & Sons' English Steel in our saws and the name speaks for itself.

*French Band Saws, Emery Wheels and General Mill Supplies.*

**66, 68, 70 and 72 Fort St. East, DETROIT, MICH.**

### Investment Bonds.

**THE DOMINION SAFE DEPOSIT WAREHOUSING & LOAN CO.,**

Head Office—The Canadian Bank of Commerce Building, King St. W., Toronto.

**CAPITAL, ONE MILLION DOLLARS.**

**DIRECTORS.**

W. D. Matthews, Esq., President.	Henry W. Darling, Esq., Vice-Pres
John I. Davidson, Esq.	S. F. McKinnon, Esq.
H. W. Nelson, Esq.	J. P. Clark, Esq.
M. C. Cameron, Esq.	Robert Kilgour, Esq.
Thomas McCracken, Esq.	Robert Davies, Esq.
	Aaron Ross, Esq.
	G. B. Smith, Esq. M.P.P.
	J. H. Starr, Esq.
	Alexander Nairn, Esq.
	Eugene O'Keefe, Esq.

This Company is now issuing \$100, \$200, \$300, \$400 and \$500 investments in bonds, payable in five, ten and fifteen years from date of issue, with participation in profits, affording all the advantages of compound interest accumulations on small sums of money. These bonds are the obligations of this Company and are specially protected by a sinking fund, invested in first-class real estate mortgages. They are plain definite contracts, subject to no contingencies whatever, are non-forfeitable after one annual payment with values definitely stated thereon. For a small outlay they secure a fixed and generous return.

To bondholders who complete their contracts the Company guarantee compound interest at the rate of Four Per Cent. Per Annum.

The Company is prepared to receive applications from reliable agents at all points where it is not already represented.

**WM. KERR, Manager**

The Safe Deposit Vaults of the company cannot be surpassed for absolute security. Call and examine or write for circular

80 H.P. CUT OFF COUPLING.

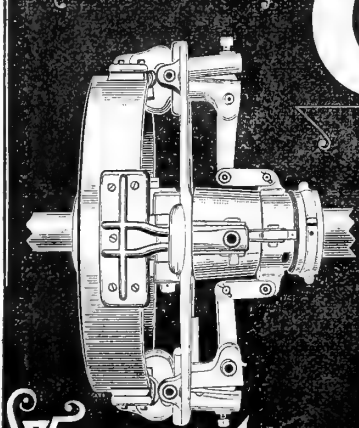

**WATEROUS ENGINE**

# GRIP

**Pulleys & Cut off Couplings.**

INCHES INCHES  
**10 x 3 TO**  
FEET INCHES

**SPLIT OR SOLID**

**GUARANTEED.**

**AFTER USING YOU WONDER HOW YOU MANAGED WITHOUT IT.**

**WKS. Co. Brantford, Can.**

**A. M. DODGE & CO.**  
**M**ANUFACTURERS of and Wholesale dealers in all kinds of Lumber, Lath and Shingles. Tonawanda, N. Y.

**COWPER & GREGORY.**  
**R**ECEIVERS and Forwarders of Lumber, Lath, Shingles, &c. Unexcelled facilities for shipping by canal or rail. Tonawanda, N. Y.

**CHEESMAN DODGE**  
**T**IMBER and Lumber Merchants. Ship and Boat stock, Railroad Ties, &c. Office, 16 West Seneca Street. Buffalo.

**EMMET FLEMING**  
**I**NSPECTOR and Commission dealer in Lumber. Office, 251 Louisiana Street, Buffalo, N. Y.

**LAYCOCK LUMBER CO.**  
**M**ANUFACTURERS of Pine, Hemlock and Oak Timber up to 85 feet in length. Saw Mills: Ackley, Pa., Black Rock, N. Y., Gravenhurst, Ont. Office, corner Main and Seneca Sts, Buffalo, N. Y.

**J. & T. CHARLTON**  
**W**HOLESALE dealers in Masts and Spars, Canada Round Pine, &c. Tonawanda, N. Y.

**WILLARD W. BROWN.**  
 202 Main Street, Buffalo, handles all kinds of Hard Woods.

**A. P. & W. E. KELLEY CO.**  
**W**HOLESALE Lumber dealers. Yards at Tonawanda and Chicago. Correspondence invited.

**C. P. HAZARD.**  
**W**HOLESALE dealer in Lumber, Shingles, Lath and Fence Posts. Correspondence invited from the Canadian trade. No 92 River Street, Buffalo, N. Y.

**L. A. KELSEY LUMBER CO., (Ltd.)**  
**M**ANUFACTURERS and dealers in Hardwood Lumber of all kinds. Describe stock and write for prices. Office Tonawanda, N. Y.

**BOVEE & HOWDEN**  
**M**ANUFACTURERS and Wholesale dealers in Hard and Soft Wood Lumber. Holders of Canadian stocks are invited to write for quotations. Offices at Tonawanda and Le Roy, N. Y.

**THE TONAWANDA LUMBER CO.**  
**M**ILLS at East Tawas, Mich.; office 106 Main Street, opposite N. Y. C. and H. R. R. R. Station, North Tonawanda, N. Y.

**Cash for Lumber**

W. N. McEachren & Co.

Wholesale dealers in all kinds of

**HARDWOOD LUMBER**

NO. 3 DOCK  
 TORONTO

WRITE US FOR PRICES AND SIZES TO CUT.

WE PAY CASH WHEN LOADED ON CARS.

HERBERT G. ROSS. Box 278. REGINALD C. BLAKER

**H. G. ROSS & CO.**

Real Estate, Fire and Life Insurance, Shipping and General Commission Agents.

Timber Limits and Farming Lands a Specialty.

A.B.C. Code, Cable address, "Ross."

**NEW WESTMINSTER, - - - B. C.**

CORRESPONDENCE SOLICITED.

**LUMBER TRUCK \* WHEELS.**

**The Montreal \***

**\* Car Wheel Co.**

MANUFACTURERS OF

**CHARCOAL IRON CHILLED RAILROAD WHEELS**

Offices: New York Life Insurance Building, Montreal.

Works: Lachine, Quebec.

WE make a Specialty of Wheels suitable for the requirements of Lumbermen and Street Car Service, and can supply them Bored, Finished and Balanced.

CORRESPONDENCE SOLICITED

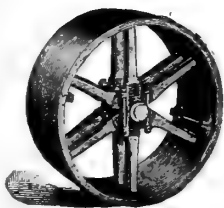

Menasha Hickory Pulleys  
 We make the only hardwood bent rim spoke arm split pulley, only small split pulley, only wooden hangers in the market. Send for discounts & circulars.  
 Menasha Wood Split Pulley Co. MENASHA, WISCONSIN.

**THE MONARCH BOILER AND HERCULES ENGINE.**

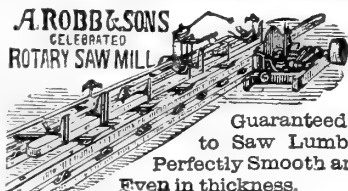

Guaranteed to Saw Lumber Perfectly Smooth and Even in thickness.  
 Portable from 6 to 70 horse power. Surpass portable steam power heretofore produced for strength, durability, compactness, and the ease with which they can be moved.

The 70 horse power can be taken over the roughest roads, or into the forest, and set up as easily and quickly as an ordinary 20 horse power portable engine, and as firm as a brick-set stationary engine. Engines and boilers of every size and description. Rotary Saw Mills, Shingle and Lath machines, Law Grinders, Planers, etc. Mill machinery and supplies of every description. Every boiler insured against explosion by the Boiler Insurance & Inspection Co. of Canada. Write for circulars.

A. ROBB & SONS, Amherst Foundry and Amherst, N.S. Machine works. ESTABLISHED OVER 40 YEARS.

DALTON McCARTHY, President. A. ECKARDT, Secretary. JOHN MCGREGOR, Manager

**Toronto and Midland Mfg Co.**

(INCORPORATED)

**Wholesale \* Lumber \* Dealers**

AND MANUFACTURERS OF

**DRESSED LUMBER, FLOORING**

Ceiling, Sheeting, Siding, Shelving, Mouldings of all Descriptions

Office and Yard:

**FOOT OF SPADINA AVE., - TORONTO.**

Planing Mills: MIDLAND, ONT.

**PORTER, ROBERTSON & CO.**

STOCKS STRIPS SIDINGS BILLSTUFF

WHOLESALE

**LUMBER**

DEALERS

HARDWOODS HEMLOCK SHINGLES LATH, ETC.

Millichamp's Buildings,

35 \* Adelaide \* Street \* East, TORONTO.

YARD: NORTHERN DOCK, FOOT OF BATHURST STREET.

**NAPANEE CEMENT WORKS**

— MANUFACTURERS OF —

**Hydraulic Cement**

PARTICULARLY adapted for Dams, Smoke Stacks, Foundations, Culverts, Cisterns, Cellars, etc.

ENDORSED BY LEADING RAILWAYS AND CONTRACTORS.

**ROACH \* LIME,**

For Building, Plastering, Gas Purifying, Paper Making, &c.

**THE RATHBUN COMP'Y, DESERONTO, ONT.,**

MANUFACTURERS OF

**\* TERRA \* COTTA \* FIRE-PROOFING \***

For Use in Old and New Buildings.

Endorsed by Leading Architects. Absolutely Fire-proof. About as Cheap as Wood or Brick. Weight One-Third that of Brick. Does not Crack on application of Heat or Water.

Deadens Noise. Gives Warmth in Winter; Coolness in Summer.

**Galt \* Machine \* Knife \* Works.**



**MACHINE KNIVES**

OF EVERY DESCRIPTION FOR

Planing, Moulding & Stave Cutting.

SEND FOR PRICE LIST

**PETER HAY, - - - GALT, ONT.**

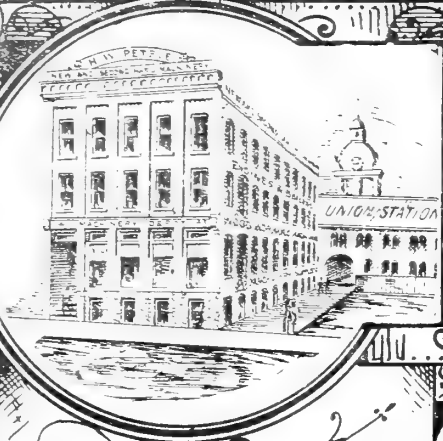

# PETRIE'S MACHINERY DEPOT.

*Special Bargains  
this Month.*

One New Eclipse Planer and Moulder, Galt make.  
 Champion Planer, Moulder and Moulder, nearly new.  
 Little Giant Planer, Moulder and Moulder, price \$200.  
 24-inch Planer and Moulder, Dundas make.  
 New Pony Planers and Moulders, only \$1.75.  
 24-inch Pony Planer, Frank & Co. make.  
 27-inch Double Surfacers, revolving bed—Cowan & Co. make.  
 No. 3 Revolving Bed planer, Cowan & Co. make.  
 24-inch Pony planer, Ross make, Buffalo.  
 No. 4 Pony planer, McKechnie & Bertram, builders.  
 Economist planer, moulder and moulder, Frank & Co. make.  
 24-inch wood frame planer, Kennedy & Sons make.  
 1 planing machine knife grinder.  
 24-inch wood frame surface planer, cheap.  
 24-inch surface planer, Rogers make, Norwich, Conn.  
 23-inch surface planer, American build.  
 21-inch wood frame planer, Kennedy & Sons build.  
 22-inch surface planer, McKechnie & Bertram build.  
 22-inch wood frame planer, in good order.  
 20-inch wood frame planer in good order.  
 12-inch diagonal buzz planer, new, Galt make.  
 Daniels planer, R. Ball & Co. make.  
 Moulder, Kennedy & Sons' make, Owen Sound.  
 Beading and moulding attachment for planer; Ross make, Buffalo.  
 No. 2 Three-sided moulding machine, Galt make.  
 3 Sided Moulder, made by Rogers. Connecticut.  
 New power morticers—Galt make.  
 One chair or upright boring machine.  
 Iron top shaper—Goldie & McCulloch make Galt.  
 Centennial top jig saw—Goldie & McCulloch builders.  
 Double cope tenoning machine—Dundas make.  
 New 36-inch resaw—Galt make—also band resaw machines.  
 Tenoning machine—without copes—price only \$60.  
 Wood turning lathes—several sizes.  
 New combination saw table—all iron and steel.  
 Improved power rod feed machine—MacGregor, Gourlay & Co., Galt, builders.  
 No. 1 shaper—all iron—Goldie & McCulloch build.  
 Improved saw arbors—all sizes—Galt make; large stock.  
 One improved iron frame swing saw—new; Buffalo make.  
 Sand paperers—new and second hand.  
 New dovetailing machine—Tyrell's patent.  
 New 30 and 36-inch band saws—Galt make.  
 New 25-inch hand saw, Cant Bros. & Co. make, Galt.  
 Four pair scroll saws and three foot power; good order.  
 Three blind slot turners, all Galt make.  
 Doge wood split pulleys at maker's prices; quick delivery.  
 Feet and hand mitreing machines, latest design.  
 Feet and hand wiring machine. Galt make.

*Send for our Illustrated Catalogue  
New and Second Hand  
Machinery.*

## H. W. PETRIE

DEALER IN

### New and Second Hand Machinery

OF ALL KINDS.

*141 and 145 Front Street West,  
Toronto, Ont.*

My new and commodious warehouse is fast filling up in every department and new lines are being continually added. Parties requiring Engines, Boilers, Iron or Wood Tools, in fact, anything in the shape of Machinery, will do well to give me a call before placing their orders.

**REMEMBER THE PLACE**

*Immediately adjoining the Union Station.*

H. W. PETRIE PROPRIETOR  
141 TO 145 FRONT ST WEST  
TORONTO, ONT.



C. C. CLEVELAND. G. F. CLEVELAND.  
**J. L. GOODHUE & CO.,**  
 MANUFACTURERS OF  
**Leather Belting**  
 AND  
**Lace Leather.**  
 DANVILLE - - QUEBEC.

THIS SPACE FOR SALE.

RAILROAD, BANK & OFFICE  
**DESKS**  
 TEES & CO.,  
 300 ST. JAMES STREET, MONTREAL.

**STORAGE OF LUMBER.**  
 We are prepared to receive any quantity of Lumber for storage. Freight and money will be advanced on same. Also, Warehouse Receipts issued, which can be hypothecated to banks and others. Storage charges easy. For further particulars apply to  
**W. LEAK & CO.**  
 Lumber, Coal and Wood.  
 DUNDAS STREET, - - TORONTO.

**GOODDAY, BENSON & CO.**  
 QUEBEC, P. Q.  
**General Lumber & Timber Merchants.**  
 Correspondence is solicited from parties having choice stocks of Hardwood and Pine to offer, either in the log or in sawn lumber.

**JOHN BERTRAM & SONS,**  
 CANADA • TOOL • WORKS  
 DUNDAS, ONTARIO.  
 MANUFACTURERS OF  
**WOOD-WORKING MACHINERY**  
 MACHINE TOOLS, ETC.  
 Write for Prices and Catalogues

THIS SPACE FOR SALE.

**GEO. CORMACK**  
 Wholesale and Retail Dealer in  
*All kinds of LUMBER.*  
 Lumber Shipped to all parts by Rail or Vessel.  
 WHITBY, - - ONTARIO

**Toronto**  
**Lithographing Co.**  
 LITHOGRAPHERS &  
 TORONTO. ENGRAVERS.

THOS. WHALEY, President. W. E. HUTCHINSON, Sec.-Treas.  
**The Whaley Lumber Co.**  
 OF HUNTSVILLE, ONT. (LIMITED)  
 Manufacturers of  
**White Pine Lumber, Bill Stuff, Lath and Shingles**  
 ALSO HARDWOOD LUMBER.  
 All orders promptly attended to. First-class facilities for shipping.  
 CORRESPONDENCE SOLICITED.

**THE RATHBUN COMPANY,**  
 DESERONTO, - - ONTARIO,  
 MANUFACTURERS OF  
**Doors, Sash, Blinds, Stairs**  
 AND ALL KINDS OF WOODEN HOUSE FINISHING MATERIALS.  
 CEDAR OIL FOR PURGING BOILERS.  
 CORRESPONDENCE SOLICITED

**The American Lumber Yard**  
**HAMBURG, GERMANY,**  
 Offers the best facilities for Yarding and Selling all kinds of  
**American Wood Goods.**  
 Address :  
 ROSENBACHER & CO., BANKERS, Hamburg. CARL GARTNER, Agent, Hamburg.

**ROBIN & SADLER**  
 MANUFACTURERS OF  
**Leather Belting**



DEALERS IN  
**Lace Leather**  
 Cotton and  
**Gandy Belting**  
 2518, 2520 and 2522 Notre Dame St. MONTREAL.  
 129 Bay Street, TORONTO.

TAPER TOOTH.



TELEPHONE 5120.

**E. R. Burns Saw Co.**

Successors to

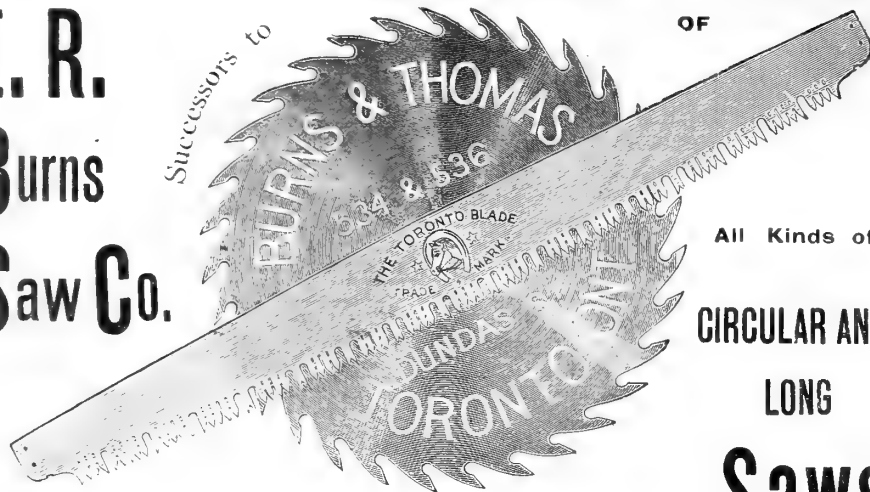

TORONTO.

MANUFACTURERS OF

LANCE TOOTH.



WORKS AT PARKDALE.

All Kinds of  
CIRCULAR AND  
LONG  
**Saws**

TORONTO AGENCY OF

**The Rathbun Co.**

ARE OPEN TO PURCHASE  
OAK, ASH, BIRCH,  
BASSWOOD  
AND  
GOOD PINE LUMBER  
CEDAR AND PINE  
SHINGLES

Manufacturers having such for sale are invited to communicate with

**T. W. WALKER, Agent  
TORONTO**

Office, Cor. Spadina Ave. & Front St.



**SCRIBNER'S LUMBER AND LOG BOOK**

Over One Million Sold.

**M**OST complete book of its kind ever published. Gives measurement of all kinds of Lumber, Logs, Planks, Scantling; cubical contents of square and round Timber; hints to lumber dealers; wood measure; speed of circular saws; care of saws; cord-wood tables; felling trees; growth of trees; land measure; wages, rent, board, interest, stave and heading bolts, etc. Standard book throughout the United States and Canada. Get the new illustrated edition of 1882. Ask your book-seller for it. Send post-paid for 35 cents.

**GEO. W. FISHER,**  
Box 238, Rochester, N. Y.  
or **A. G. MORTIMER,**  
Toronto, Ontario.

**WICKES BROS., Saginaw, Mich.**

MANUFACTURERS OF

**GANGS,  
ENGINES  
AND  
BOILERS.**

The accompanying cut represents our new No. 3 Complete Iron Frame Gang Mill especially designed to meet the demand for a smaller type of mill. The strongest and most durable for high speed and thin saws. Write for further particulars.

Southern Agents,  
**McARDLE & SINCLAIR,**  
50 & 52 Barronne St  
New Orleans, La.

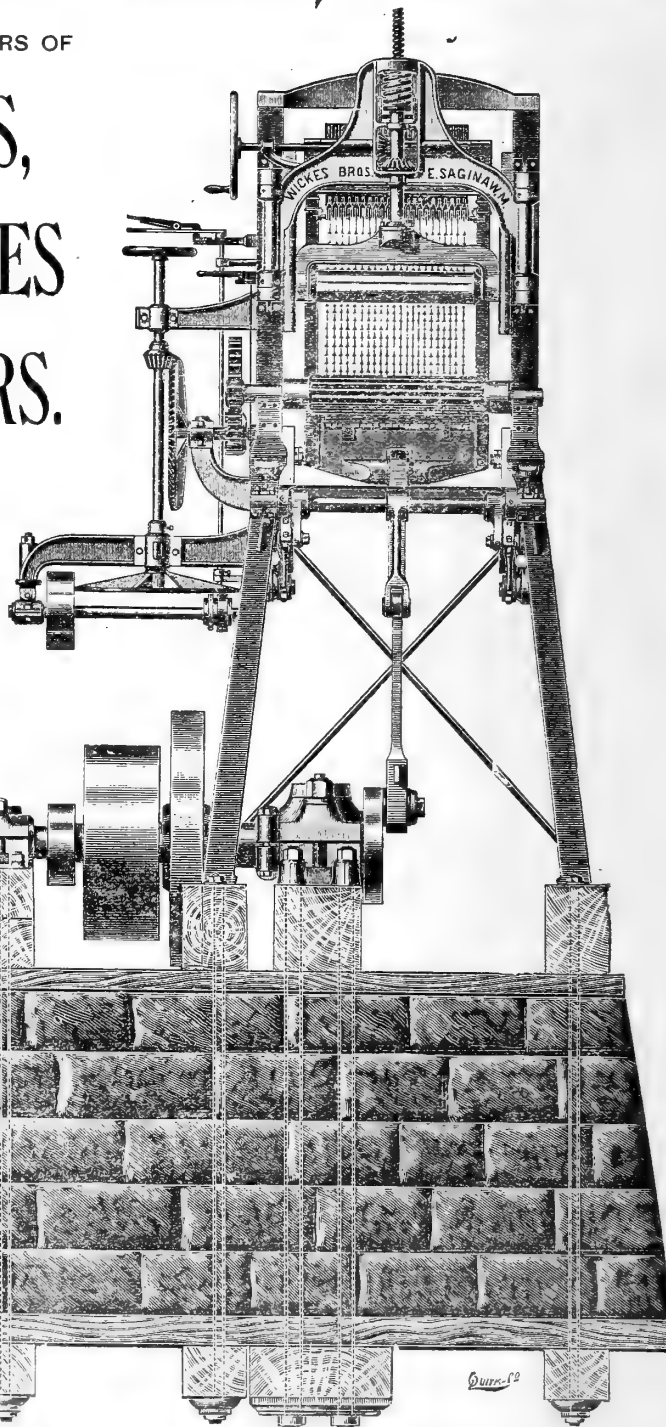

**I**MPORTANT TO LUMBERMEN  
AND ALL WHO USE

**Leather Belting.**

You all use more or less Leather Belting, and are naturally interested in knowing where to get the very best article. That which will give you the least trouble either in stretching crooked or tearing at the lace holes.

**F. E. DIXON & CO'S UNION TANNED**

Belting runs straight and easy on the pulleys, is thoroughly well stretched and cannot be surpassed for strength and durability. Send for discounts. Our hand books of leather belting mailed free on application.

Round Plaited Belts from  $\frac{3}{4}$  inch to  $\frac{1}{2}$  inch. Lace Leather.  
PATENT WIRE LACING, &c.

**F. E. DIXON & COMPANY**  
70 KING STREET EAST., TORONTO.

PATENTED 5TH MARCH, 1877.

**PARKER & EVANS.**

Sole Proprietors of the

FAMOUS INTERNATIONAL

**BOILER - FLUID - COMPOUND.**

This compound will save its cost many times in one year by saving fuel.

It eradicates scale, and when the Boiler is once Clean a very small quantity keeps it clean and free from all incrustation. One fourth the dose will prevent a new Boiler from scaling so long as it is used regularly.

Contains no Caustic Soda, and is the only matter yet known that will not injure metals in any way, and emits a clear pure steam.

30 WILLIAM STREET, - MONTREAL.

**Fawcett & Co.**

**MERCHANT TAILORS,**  
269 Queen St. E., Opp. Seaton St., Toronto.

First-Class Goods and Trimmings. Workmanship and Fit Guaranteed.  
All Orders Punctually Executed.

# THE CANADA LUMBERMAN.

VOLUME XII. }  
NUMBER 8 }

TORONTO, ONT., AUGUST, 1891.

TERMS, \$1.00 PER ANNUM  
SINGLE COPIES, 10 CENTS

## FOREST FIRES.

**A** CAMPER'S fitful fire burns low,  
Then starts afresh with lurid glow.  
Unwatched, unchained, with fuel high  
The flames grow wide, and broad and high!  
With rush and roar, and swoop and crash,  
O'er field and forest, fires now dash.  
They're here and there, and everywhere—  
The sky grows thick with pall and glare.  
The tall trees fall, and house and field  
To all-consuming fiends must yield.  
The men like demons fight the blaze—  
Back-fire and chop—and structures raze.  
Repulsed somewhat, but reinforced,  
From ruthless ruin, death, despair—  
On wings of red they ride the air.  
Through choppings dry, o'er town and lea,  
There surge the waves of a burning sea.  
Will they never cease to onward sweep?—  
The heavens now in sorrow weep!  
First gentle rain—then torrents fall,  
To drench the wood, the field and all.  
The fiery march at last is staid—  
The boon for which men hoped and prayed.  
But, count the lost and find the dead—  
Gaze on the ruin 'round us spread;  
Then on the camper's work reflect—  
The careless one who nothing recked;  
The man who thoughtless left the fire  
That grew and spread destruction dire,  
One heedless act to forethought turned,  
And never a forest fire had burned.

## BACKWOODS LUMBERING IN FLORIDA.

BY JAMES F. HOBART.

**T**HERE are many fine mills in Florida, but these are to be found near seaports, or other good shipping facilities, and cut lumber chiefly for Northern shipment, leaving local demands to be supplied with lumber by innumerable light saw-mills which are scattered everywhere through the state.

Along the line of the Florida Southern Railway are scores of these mills, and a description of one will answer for nearly all of them. A very few of these mills rival in construction and appearance the larger concerns, but as a rule they are thrown together in a very rough manner, and operated equally as rude.

These little mills are built with an aim to get out as great an amount of lumber with as little first cost or running expense as possible. Ample power is at hand in these mills, and they are never troubled by boiler inspectors. In fact, a boiler is never inspected here until after it has blown up.

One mill is built near the North branch of the Florida Southern Railway. It is but four years old, but from its weather-beaten appearance would easily pass for one hundred and four.

The first noticeable feature is the log truck, with its big wheels, eight feet in diameter, and tires six inches wide, which are not welded, but are lapped two or three feet and then riveted. A pole sixteen feet long admits of carrying a forty foot log, without its interfering with the mules.

At the extreme front end of this long pole is the "drag wheel," a unique apparatus, which skates over the sand and to a measure guides the long pole. The drag wheel also serves to prevent excessive sidewise jerks of the pole, and saves the mules from unnecessary labor.

A windlass is mounted on the axle of the wheels, and is worked by means of a long lever and rope. The "log dog" is dropped over a log which it firmly grasps upon the ice tongs principle, then both log and dog are raised by the lever and windlass, and are ready for the journey.

Into the forest for miles these log trucks penetrate, going further and further as the choice logs get scarce, forming a picturesque sight, and each double span of

mules, with its mounted driver, pace sedately along the sandy trail.

"All teams off to the forest," says the foreman, as the teams all unload before the mill, and away they go, a ponderous procession, to fetch the mighty yellow-pine logs.

With a five pound axe, fixed to a long straight handle, the Florida woodsmen cut down the huge trees with a vigor and vim unknown to the Northern chopper. It is seldom that a crooked axe helve is seen here, and the crooked Canadian axe handle is unknown. It is a singular fact that the latitude in which an axe belongs can be almost invariably determined by the amount of curvature in the handle or helve.

There is a nice calculation needed by the Florida axeman to fell timber to an inch in any given direction to escape rocks, or to allow of easier loading. It is unnecessary here, and vigorous blows throw out huge chips until the tree falls in any direction it chooses upon the level sandy plain.

The interior of the Florida saw-mill plainly shows that tasty design has never even been thought of, and combines in a ludicrous manner ingenious makeshifts, and slovenly negligence. The shafting is very much too small for the work it is required to do, and it is not uncommon to see a one and one-half inch shaft driving a double surfacer with beader and matcher heads, the small shaft driving from a forty inch pulley and only running two hundred revolutions per minute.

A bar of railroad iron held the furnace front in place, and two three-fourth inch bolts prevented the whole boiler front from tumbling down. Semi-portable boilers of the locomotive type are in general use. They are run for all they are worth and last until they burst or burn out.

The circular saws in these mills are peculiar; they must be very strong, especially at the roots of the teeth in order to stand the strain of cutting the terrible hard knots which are constantly being met with in yellow pine. The hemlock and spruce knots bear no comparison with the yellow pine knots, and even a good axe will be spoiled unless great care is taken when cutting a knot.

As lumber falls from the saw, it is received by a line of dead rolls, and pushed under a swing saw, when it is cut to the desired lengths. Logs thirty to forty feet long are mostly cut, making two or three bounds from each length cut off by the saw.

A gang jointer stands near the swing saw, and upon it the boards can be cut the desired width of square edge lumber, and, at the same time, a picket cut from either side, should any part of the round edge board be of sufficient width to make it.

From the edges the boards naturally pass to the surfacer, and odd corners about the mill are occupied by a lath machine, shingle mill and a superannuated jig saw. Upon this machine, and held in place by wire, is a board bearing a notice which flavors decidedly of the true Florida "cracker."

The homely ingenuity displayed by the "repair men" of these mills is well worthy of study. The throttle valve got to leaking, the stuffing box bolt threads stripped, and in trying to remove the studs they broke short off, leaving a very bad leak of steam.

The valve stem was repacked very full, the gland put in place and held by two pine wedges driven in, one on each side of the valve stem.

A boiler tube got to leaking and was promptly suppressed by topping a thread in either end, then common pine plugs were screwed therein, stopping the leak with only the loss of the tube's heating surface.

The saw dust conveyors around these mills contain the very essence of mingled ingenuity and laziness.

They are usually made out of a worn out rubber belt or perhaps a new one of canvas, and run from a pulley beneath the saw to some place outside the mill where, instead of running 100 feet further and delivering the waste upon a heap, the belt stops short and is supplemented by a negro and two wheelbarrows, one of which is filling while he empties its mate. The millman also is kept busy by wheeling his dust and shavings entirely around one end of the mill, together with a dozen piles of lumber.

About once an hour the saw dust convey gets too slack to be driven by frictional contact with its drive pulleys. This is quickly cured, however, by two quarts of water, which is dashed upon the belt, forming an efficient but short-lived tightener.

The output of these mills is often used green, as it comes from the saw, but it often lies in shiftless piles exposed to sun, air and wind, until it is twisted out of half its resemblance to lumber. Florida lumbering has many "points well worth imitating, also many which should be improved."

## TREE OIL AND TALLOW.

**B**BRITISH Consul Hosie, in his report on the trade of Wenchow, China, for the year 1890, gives the following information relating to vegetable tallow and oil derived from the tallow tree, "Stillingia sebifera," which is largely cultivated near Wenchow, and still more widely within the Ch'u-chou prefecture to the west: "It is not generally known that the fruit of this tree produces oil as well as tallow. The berries which resemble coffee beans in appearance and size, are first steamed and then pounded in an ordinary rice trough. By pounding, the soft mealy mesocarp is partially separated from the kernels. The mass is then placed in a bamboo sieve, the meshes of which are just large enough to allow the mealy matter to be scrubbed through, and small enough to keep back the kernels, which are hard, black and about the size of peas. From the mealy matter the tallow is expressed in primitive wooden presses. The oil is derived from the kernels in the following manner: They are dried and passed between two millstones held at such a distance apart by means of a bamboo pivot as to crush the hard shells of the kernels without injuring the white interiors. The mass is then passed through a winnower, which separates the broken shells from the solid matter. The latter is then placed in a deep iron pan and roasted until it begins to assume a brownish color. The crushed shells make an excellent fuel for the purpose. It is then ground by a huge steam roller in a circular stone well, steamed, made into circular cakes with bamboo and straw casings, and passed through the wooden press. A good lighting oil called 'ching yu,' of a brownish-yellow color, is thus obtained. The tallow is 'pi yu,' that is skin, or external oil."

## WHERE THE LUMBER GOES.

**W**HERE does all the lumber go that is cut each year? Hundreds of millions of feet go into the thousands of houses built each year in city, town and country. The agricultural implement makers consume 100,000,000 feet yearly, mostly oak, ash, maple and hickory. The furniture manufacturers use 300,000,000 yearly, nearly all hardwood. The waggon, carriage and buggy makers consume more than 100,000,000 feet annually. These are a few of the places where it goes.

A man's chances for life are good and his glory magnified when he enters the forlorn hope for a charge on the enemy's works. He has no chances for life, and is written down a fool, when he engages to set a screw on a revolving shaft.



## SAW MILL BUILDING.

BY J. H. MINER.

**I**N BUILDING a saw mill or medium mill to manufacture good lumber cheaply, we will begin first at the engine and boiler. A good center-crank engine and straight tubular boiler are best. An engine of this kind possesses many advantages, in that it is set and keeps in line, and is more compensating than a side-crank, and is less expensive to set. The fire-box boiler will not steam well unless dry fuel is at hand, and will not burn the saw dust. They are difficult to clean, which few mill men pay close attention to. The slabs, in many cases, can be worked into lath, which means money, or sold for fuel. In some places the dust commands a good price. The idea is, burn the worthless stuff. It is cheaper to get rid of the slabs and edgings with a burner, as no mill can burn all the slabs, but can burn the dust, which is cheaper firing, as an intelligent boy will keep steam.

To burn dust the boiler must be set with the end say two feet ahead of the discharge of dust from the saw. The conveyor will traverse this route. It must be made of link chain belting with an iron cleat every eight or ten feet, with two spouts, one on each side of the boiler, made of sheet iron, with cut-offs. Have stack plenty high and there will be good draft if there is ample grate surface, and after getting your furnace hot your dust will disappear without a cent of outlay except a fireman at fifty cents per day.

If slabs are to be used for fuel, set your boiler the opposite way. Have a glass water or float gauge in sight of the sawyer. Use a good plunger pump or an injector that can be regulated.

Set the engine on a heavy piece of timber, well bedded in ground and of good length. Build up from this the height you wish engine, using bolts clear through, with all timbers keyed firmly together. A brick foundation is not good unless set very deep, with broad base, which costs considerable more. On every bearing of your engine have a thoroughly reliable oil cup and use a sight-feed cylinder lubricator, all which should come with the engine and will if you insist. Only a drop of oil occasionally will keep your engine cool. Use a cup that will save oil, and that you can depend on while at the saw.

By all means exclude your engine from dust and dirt—its enemies. A few sash cost but little and the lumber is handy. Build an engine room, having the light so arranged that the sawyer can see the engine. Use a reliable compound ring packing for rods; it will last four times as long as hem, no friction nor cutting of rods and is quickly inserted. Your engine properly set requires no engineer but the sawyer's attention morning and noon. Exclude the dust and use reliable oilers and you will have a new engine when your neighbors' has burned, thumped and worn itself out.

A high speed engine is the best. They cost less per horse-power, as a 40-horse slow motion will cost as much as a 60-horse fast engine.

Buy a saw mill with a heavy husk and steel mandrel with long bearings. The driving pulley should have a heavy rim, which should be well balanced. Turning a pulley inside does not insure perfect balance. The heavy rim will add to the cut and will carry a slacker drive belt. A thin-rim pulley has no momentum in it to relieve the saw in knots and tough places.

The feed works should have very broad face pulleys, that they may be easy to regulate and quick in operation. The feed-belt should not be less than four inches on a small mill, while six inches will be better. Broad face frictions give the sawyer a variable feed, while narrow pulleys quickly wear from excessive pressure, slipping and burning. There are a great many dollars annually lost on trifling feed works.

The carriage should run on planed ways, with large trucks with axles extending across. Use a good ratchet set works with reliable dog. Put in an overhead log turner. Put in live rollers, which can be cheaply gotten up for small mills, and swing cut-off saw, with a measure on each side, so that defective lumber may be trimmed. Use a light car and ironed track for distributing lumber.

Ground mills seldom have an edger, and mills of less than 10,000 capacity do not need one. Buy the best

extra rubber belting. Use belt hooks properly and every belt in your mill will be endless and reliably fastened. Use a good inserted tooth saw and top saw, if timber is large.

## MILL FIRES AND INSURANCE.

BY C. R. TOMPKINS, M. E.

**T**HE good working qualities of almost any piece of machinery frequently depends upon the foundation upon which it rests. It is not only much easier to arrange and adjust the several parts of a new machine in the first instance, but it is much less trouble to keep the machine in perfect adjustment afterwards, where a good foundation is provided. But aside from this it becomes doubly so in case of fire. Machines that simply stand upon the floor, no matter however good and strong it may be, when it is burned away they will settle down so as to frequently stand upon two legs, if they are not thrown over; with such conditions it does not require a very hot fire to warp them so much out of shape that but little is available for the purpose of rebuilding.

It is a well-known fact to all iron-workers, that cast iron will stand considerable heat without material injury, where there is no strain upon it; while, on the other hand, where it is submitted to a strain, it requires but a moderate heat to produce a permanent set. For this reason, machines that have passed through a fire are more frequently ruined than from the actual heat they are submitted to. Heavy planing machines standing upon a good stone foundation have gone through a pretty hot fire without permanent injury, except to some of the lighter portions and pulleys, that may be replaced at comparatively a small expense; while others, equally as heavy, without an independent foundation, have settled down in such a shape as to be completely ruined by warping and breakage, with much less heat than the former.

With steam engines this is more particularly the case. The method of placing an engine upon a wooden bed and supporting the end of the main shaft upon a wooden support, which is extensively practiced in all parts of the country, especially in saw mills, can not be too severely condemned by practical engineers. Frequent cases are met with where engines thus set up have passed through fire and been totally ruined by being warped out of shape and cracked; whereas, if they had been mounted upon a good stone or brick foundation, and the end of the shaft also permanently supported upon the same kind of structure, the damage from the same fire would have been slight, and a few dollars would have made the loss good. By being put up in this manner, without permanent support to the end of the shaft, as soon as that burns away the whole weight of not only the shaft, but the fly-wheel and pulleys, is thrown upon the main box. The result is the engine bed, which is one of the most important parts, is twisted out of shape and ruined. If no other part but the bed is totally ruined, the expense of putting in a new bed will frequently amount to nearly as much as a new engine.

As a rule, however, if the engine and boiler are properly set up, with good foundations, in case of fire they suffer less damage than any other part of the machinery in a mill. Yet we frequently find mills that carry a large amount of insurance upon the engine and boiler, and much less in proportion upon the lighter machinery which is always liable to much more damage by fire, if not a total loss. In a large majority of cases where a mill is burned, especially a planing mill or a saw mill, it will be found that the insurance will seldom cover the loss on the machinery and tools, while the engine and boiler, if properly set, are not as a rule damaged more than one-half that amount.

Therefore, where a certain amount of insurance is carried, it is for the advantage of the mill owner to place the engine and boiler in a one-story detached building. Place them on good substantial brick or stone foundations, and carry a small amount of insurance. Put the bulk of the insurance upon the machinery in the mill, that is more liable to be totally destroyed in case of fire.

## THE PRESERVATION OF TIMBER.

**I**N THE history of attempts at prolonging the life of timber some very curious expedients are met with. In 1836 Dr. Boucherie, a French chemist, tried to impregnate timber by vital suction—that is, by tapping the tree and allowing the ascending sap to carry up a preserving solution. This, however, did not give satisfactory results, and in place of it a cap was supplied to the end of a newly-cut log, and the solution forced along the sap ducts by hydraulic pressure. Sulphate of copper was the chemical used, and when it was applied to newly felled timber it gave good results. Lime water has been tried, and also salt, but the effects have not been such as to encourage the repetition of the treatment. There is a strip of road in the Union Pacific railroad, in Wyoming, where the sleepers do not decay at all. The analysis of the soil shows that it contains sodium, potassium, chloride, calcium, and iron, which act as preserving agents. An inventor named Foreman brought out a process by which dry arsenic and corrosive sublimate were inserted in holes in sleepers and covered with plugs. The materials became dissolved and effloresced on the surface, when the cattle licked them and died by scores. The farmers rose in arms and forced the railroad company to burn all the sleepers. One of the best of recently devised methods of preserving timber consists simply in soaking the timber in melted naphthaline for a period varying from two to twelve hours, depending upon the bulk of the piece. A temperature of 180 to 200 Fahrenheit is obtained by placing steam pipes in the bottom of the tank which contains the material. Simple as the process is it possesses a still more valuable feature. It can be applied to green timber, thus obviating the necessity of a long and expensive process of seasoning. The naphthaline penetrates the pores of the wood, decomposing the albumenoid compounds and displacing both sap and water. It then becomes fixed, and the whole substance is thoroughly permeated with an anti-septic of a permanent character.

## ANTIQUITY OF THE CARPENTER'S PLANE.

**A** VERY interesting discovery has been made at the Roman city of Silchester. The excavators came across a dry well, which, on being explored, proved quite a little museum of antiquities. Some fifteen feet down, a correspondent says, the diggers found an unshaped pottery vase, about a foot in length, quite intact, and curiously enough, protected by lumps of chalk built around it. The vase, which probably originally contained some precious substance, was, however, quite empty. Above it were deposited a great number of iron implements, most of which were in a wonderful state of preservation. They seem to have been the tools of a carpenter and a coppersmith or silversmith, with some miscellaneous objects of blacksmith's work thrown in. The principal specimen is a carpenter's plane of quite modern type, although unquestionably more than 1,500 years old, three or four axes retaining their fine cutting edges and quite serviceable, a number of chisels and gouges of all shapes and sizes, hammers, adzes, saws files, etc. In the smith's department may be specified a brazier for burning charcoal, quite complete; two or three anvils of different sizes and shapes, a fine pair of tongs adapted for lifting crucibles, a curious tripod candelabrum lamp, or candlestick, and several other curious objects the precise uses of which have not yet been determined. In addition there are several large bars of iron. Probably more will be found deeper down in the well. This is undoubtedly the most important find at Silchester since the discovery of the bronze Roman eagle, now at Strathfieldsaye, some years ago.

One very important cause of deterioration in boilers is due to the fact of their becoming too small to do the work without forcing, so that the pulsations of the engine cause a well marked succession of shocks on the boiler, which result in the weakening of the material. By placing one's hand on the head or shell of the boiler, the vibrations of the metal can be felt similar to the rising and falling of a man's chest while breathing.

## USEFUL INFORMATION

Have all your boilers well inspected,  
And never let them be neglected;  
Keep your water well in sight,  
Never below the proper height.

An insurance man of long experience declares that milk is the best obtainable extinguisher for petroleum fire. If milk is not at hand flour will answer nearly as well for putting out the flames.

When a belt breaks from a fair strain, it bursts nearly straight across at the weakest part. When a belt is broken diagonally across the solid leather, then be sure it is torn by something else than fair strain.

A German engineer has devised a new method for fixing a foundation under water. By means of a powerful blast of compressed air he drives powdered cement down into the sand or mud at the bottom of a stream. The action of the water immediately fixes the cement, and it becomes like solid rock.

Twenty-five per cent. economy in the use of steam does not mean the same degree of economy in fuel. Owners of steam plants have been deceived in this way and very often look upon meritorious devices with suspicion because they did not use one-quarter less coal after buying a device recommended as above.

Some operators make endless leather belts by using common glue to make the joint. One of the advocates of this method says: "Bevel the ends nicely and smoothly. Put the glue on and place the splice in a vise for some time. I have had such splices on the heaviest kind of work, but it has never yet failed to hold."

It is my opinion, says Edward N. Dickson, that with our present knowledge of machinery, a steam engine can be built that will produce a horse power with three-quarters of a pound of coal an hour, if of sufficient size to reduce the percentages of loss by radiation to a minimum. Under those circumstances your fuel expense would be less than one-third of what it now is.

If the grate surface under a boiler is larger than is necessary to burn the required amount of coal, it is neither economy, convenience nor good judgment to retain the full surface, as better results with less labor and more economy in fuel, would be obtained by shortening the grates to such an extent that from eight inches to twelve inches of fire would be required at all times.

In summing up the things that a man should look out for in caring for a steam plant, a man should first study his plant thoroughly. He should know just where each pipe goes, its condition, and the condition of the boiler. He must study the results of other people's work and methods, and apply them to his own work. He must see that there is no waste of steam or of coal, either directly by leakage and carelessness, or indirectly by dirty tubes and laziness. He should also study his engine, read what such a machine can and should do, then try to bring his own engine as near as possible thereto. The machinery should be kept up in such condition that no shutdown and general overhauling will be necessary. To do this, all little repairs must be made "just before they are needed," and not wait until just after. To do all this a man must be a good engineer. He must learn something everyday, and such a man will pick up knowledge as easily as a shaggy dog picks up dirt. The man who "knows it all" will never make a good engineer. A man must always be ready to learn something new, and often does it from an engineer who knows less than he does.

When a nail or spike has been driven into a live tree, or into timber, after a year or more the fibers of the wood will have contracted so tightly about the metal that it will be exceedingly difficult to withdraw the iron. But, strike a nail or spike a sharp blow with a hammer and drive it in a trifle so as to break the wood fibers around the metal, and a nail can be drawn with only a little force. Iron gate hinges are frequently driven into a living tree. When one is not in possession of a strong claw bar, bore a hole close to the hinge on the under side and the hinge can be easily crowded down into the hole and withdrawn. When a large nail has been driven head and all beyond the surface of the timber, bore a hole close to the nail, and with a nail set crowd the nail into the hole. When nails have become rusty, they will usually break in two, leaving a portion of the iron in the timber. But, strike a rusty nail a sharp blow, and one can sometimes withdraw it with his fingers. In tearing down an old building, if it is desirable to take off the boards or casings without splitting them, place a nail set on the head of each nail, and with a hammer start it inward about the eighth of an inch. One blow will break the hold of the nail so that most of the nails will come out when the boards are driven off.

### THE SETTER'S PLACE IN THE MILL.

MUCH has been written of the important places among the operating force of the saw mill. The filer has been written up and written down, and hand books have been compiled for his benefit. As a general rule he gets credit for a great deal more than he deserves, whether of blame or praise. If all goes well and the mill turns out well-manufactured lumber, with a good profit to the owner, the filer is patted on the back. If, on the contrary, the mill does poor work and little of it, he gets more blame than even the foreman.

The sawyer comes next for his share of blame or praise. In fact, he, too, gets both, often unmerited, especially in the matter of blame. More especially is he blamed for faults which should be charged to bad filing, machinery out of line, rickety carriage, a sprung mandrel, or similar causes which should be charged to the neglect or ignorance of the foreman or superintendent.

The edger man comes next in the category, and, indeed, often gets quite as much attention as either of the others; and, it must be confessed, he seldom gets more than he deserves. The edger man can pretty nearly make or unmake a saw mill, and can thrust his hand deeper into his employer's pocket than any other employee about the establishment.

The trimmer also gets a good deal of attention, and rightfully; while the engineer is generally the most petted man of the entire crew, often assuming the lordly air of a hotel clerk.

But there is one man in the mill whose position and importance is hardly even appreciated. That man is the setter, who rides back and forth from morning till night, plying the lever that gauges the entire output. His work in a bill mill, or in any mill cutting fractional thicknesses, can hardly be overestimated. Of course he is, to a certain extent, under the orders and direction of the sawyer. But from that view of it his quickness of perception in catching the sawyer's ideas as signaled him, and his promptness in execution, are strong points.

The setter's work is arduous, especially in a bill mill. The wear and tear of riding back and forth on the carriage 11 hours in a day, subject to the jerks and dizzy see-sawing, often unnecessarily aggravated by a nervous sawyer, is no light thing of itself, even after months of experience. The muscular effort of throwing the lever, supplemented by the muscular tension necessary to his balance on the rapidly-moving carriage, requires great physical endurance and an almost involuntary command of every part of the body.

In addition to an eye quick to comprehend the sawyer's signals, the setter must have the half-dozen bills on his bulletin board thoroughly in mind, and be quick to see what item the log will fit; or, if defects develop, as it is sided up, to see what next best to put into without a moment's stop of the carriage. To hesitate is to lose a cu., and perhaps spoil the whole log. He should also be a good judge of qualities, and especially of the quality required in special bills, like bridge and car material. This is a point too often neglected. More attention to this, and a better knowledge on the part of the setter would save many a log from being run into a bill and sent to the dock, only to be rejected by the shipping clerk or by the inspector at point of destination. A log having once been cut into a special size for a bill it is next to impossible to convince even the proprietor that it should not be shipped. Of course he is expected to have a correct eye for lengths, or to be able to catch the word quickly from the scaler on the log deck.

But it is in the cutting of good logs into graded stock that the setter can make or lose his wages with a facility only equalled by the sawyer and edger man. It is astonishing how little this point is understood, and how little attention is paid to it. No matter how well up the sawyer may be in this respect, his best efforts will be rendered comparatively useless, unless the setter responds quickly and intelligently. This has come to be especially true of the setter in the band mill, which is now doing the highest class of work, superseding the gang in many instances.

That education can be got on the carriage, but in that case it will largely be at the expense of the mill. The setter should learn his qualities in the yard or on

the shipping dock before mounting the carriage. In fact, the only thing that he should have to learn, and that should be the actual mechanical work of the place and the sawyer's signal code. His errors would then become only such as a little practice, in the application of what he has already learned, would readily and quickly correct.

It is a wonder this subject has not received more attention from mill men and log owners, and that the setter was not long ago accorded his true rank in the working force of the saw mill.—*Northwestern Lumberman.*

### THE IMPORTANCE OF SMALL THINGS.

ONE of the most important things in modern engineering of all kinds is the accuracy employed in measurement. The thousandth part of an inch is exceedingly small when examined by the eye, but there are places in engines and other machines where this amount of lost motion would be all but ruinous. The difference between a good working and a good driving fit may be about twice this amount in most places. People who are accustomed to measure with a two-foot rule generally consider that one-half of a sixteenth is as close a measurement as can be conveniently made, while the machinist working at the lathe and testing work by calipers can readily detect a difference of much less than one-thousandth part of an inch, and then again there are cases where more space than this must be allowed, as for instance between journals and their bearings to permit the flow of the lubricant. Occasionally it will be noticed in the adjustment of caps on journal bearings, that there will be a space of one-eighth of an inch or more left between the cap and the journal. This, of course, is not good practice, as the oil supplied to the bearing is not spread over the top of the shaft, but rather is carried over and spread out by the lower half of the box and the oil or other lubricating material is wasted. Where a journal is heavy enough to maintain its seat in the bearing, no special harm is done further than the waste of oil, but if the weight on the shafting be insufficient to hold in position, as is frequently the case with a light shaft, more or less trouble usually follows such a careless adjustment. Take for instance the fit between the valve and its seat. There must be absolute contact between iron and iron at all points, or considerable leakage of steam will be the result. To make this closer fit requires considerable more work and closer attention than the rougher job, but the results obtained in less wear and economy of operating, more than pay for the extra work required. This may readily be observed in the case of all high grade machinery. The greater excellency of workmanship necessarily make the machines cost more, but this is soon paid for by their more economical operation, as a person in charge of a machine, if he be a mechanic, will take a certain amount of pride in devoting considerable attention to keeping it clean and in the best of order, and the better the grade of workmanship that has been put on the machine the more attention and better care he will give it. High-class machinery includes fine workmanship and should only be placed in the care of men who are able to appreciate the reasons for putting the finer finish on such machines.

### RICH MAHOGANY.

A MAHOGANY tree lately cut in Honduras made three logs which were sold in Europe and brought \$11,000. The mahogany tree ranges from one to seven feet in diameter, is often sixty feet to the first branches, and frequently exceeds ninety feet in height. The Honduras mahogany comes to market in logs from two to four feet square and twelve to fourteen feet long, planks sometimes being obtained that are seven feet wide. The weight of a cubic foot mahogany varies from thirty-five to fifty-three pounds. As compared with oak, which is called 100 per cent., the strength of mahogany is 67 to 97, its stiffness is from 73 to 93, and its toughness from 61 to 99 per cent. The Government engineer of Honduras estimates the total value of the trees, such as are regarded fit to be cut, at \$200,000,000, while the smaller trees, not ready to be cut, are also worth a large amount.

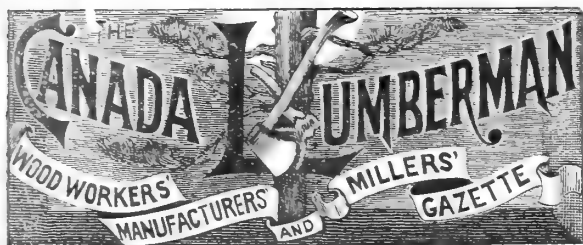

PUBLISHED ON THE FIRST EACH MONTH BY  
ARTHUR G. MORTIMER.

OFFICE:  
75 CANADA LIFE ASSURANCE BUILDING,  
TORONTO, ONTARIO.

TERMS OF SUBSCRIPTION:

One Copy one Year, in Advance, - - - - - \$1.00

One Copy six months, in Advance, - - - - - 50

Foreign Subscriptions \$1.25 a Year.

Advertising Rates Furnished on Application.

THE CANADA LUMBERMAN is published in the interests of the lumber trade and of allied industries throughout the Dominion, being the only representative in Canada of this foremost branch of commerce of this country. It aims at giving full and timely information on all subjects touching these interests, discussing these topics editorially and inviting free discussion by others.

Special pains are taken to secure the latest and most trustworthy market quotations from various points throughout the world, so as to afford to the trade in Canada information upon which it can rely in its operations.

Special correspondents in localities of importance present an accurate report not only of prices and the condition of the market, but also of other matters specially interesting to our readers. But correspondence is not only welcome, but is invited from all who have any information to communicate or subjects to discuss relating to the trade or in any way effecting it. Even when we may not be able to agree with the writers, we will give them a fair opportunity for free discussion as the best means of eliciting the truth. Any items of interest are particularly requested, for even if not of great importance individually, they contribute to a fund of information from which general results are obtained.

Advertisers will receive careful attention and liberal treatment. We need not point out that for many the CANADA LUMBERMAN, with its special class of readers, is not only an exceptionally good medium for securing publicity but is indispensable for those who would bring themselves before the notice of that class. Special attention is directed to "WANTED" and "FOR SALE" advertisements, which will be inserted in a conspicuous position at the uniform price of 15 cents per line for each insertion. Announcements of this character will be subject to a discount of 25 per cent, if ordered for three successive issues or longer.

Subscribers will find the small amount they pay for the CANADA LUMBERMAN quite insignificant as compared with its value to them. There is not an individual in the trade or specially interested in it, who should not be on our list, thus obtaining the present benefit and aiding and encouraging us to render it even more complete.

#### WHO IS BLAMABLE ?

A PAINFULLY unpleasant section of the news columns of this journal each month is the "Fires and Casualties." The items published tell of serious loss of property, coupled sometimes with loss of life, and always with great inconvenience and distress to the owners of the property destroyed, and the hundreds of workingmen dependent upon them for a livelihood. Is all this inevitable? We may be Calvinists in religion, but when we get down to business, we are convinced that more fires occur as the result of downright carelessness and ignorance, than because it has been decreed, that they should take place. An item is before us at this writing, of a lumber yard, stores and other buildings burned down. How? The old, old story—children, matches, fire. Could not be helped. Children will be children—we are perhaps told. Do not talk arrant nonsense of this kind, when the matter is so serious. Children will not play with matches, if those who are responsible for their management, teach them different; and if this teaching is neglected, then care can be exercised to keep matches out of their way. It may be that a fire occurs because something that is capable of generating combustion is thrown down among the saw dust of a mill, there to remain until, in the stillness of the night, when the thoughtless act has gone from memory, the mill is discovered a mass of flames. "Did not know that any harm would come from this simple act?" Somebody should know; and it should be his business not only to impart this information to all directly concerned in the work of the mill, but to place it in so conspicuous a place that no man or boy could say he did not know. The CANADA LUMBERMAN, through its "Useful Information" column and other departments is constantly imparting inform-

ation of this character. Excuse can be taken from no man in this age of magazines and books, devoted to special interests, for not knowing all that he should know concerning his special business.

Reference is unnecessary surely to the fires that are constantly occurring through the carelessness of a smoker, or the negligence of a fireman, or oversight or indifference of some employee, whose especial duty it is to be careful, exact and faithful in his work. Unsympathetic as the words may seem, acts of this character, when freighted with so terrible results, can only be described as bordering on the criminal; and punishment commensurate with the evil done should be meted out to the guilty ones. And what apology shall be offered for the "campers' fitful fire:"

The careless one who nothing recked;  
The man who thoughtless left the fire  
That grew and spread destruction dire.  
One heedless act to forethought turned  
And never a forest fire had burned.

Every one will sympathize with the man who loses a limb, or breaks a leg, or suffers the loss of even a finger, while engaged in his daily work. It would seem cruel not to extend to him this sympathy, when physically he is a sufferer, and besides he must lose time and money consequent upon the accident. And as the work of our saw mills grow and the number of employees is multiplied, these unfortunate fatalities increase. Yet, one who is at all observant and follows the causes of a large percentage of the chronicled accidents of each day, must be satisfied that gross carelessness is at the bottom of much of the trouble. Fatalities of this kind differ from fires in that, while the individual loss and suffering may be greater, the disaster in its entirety will hardly be as widespread, either as to numbers concerned or financial loss.

But the same causes give birth to both, and proper carefulness and thought applied in the two cases will act alike, in a large measure, as a preventative and remedy.

#### LABOR TROUBLES.

THE labor troubles among the mill men of St. John, N.B., particulars of which were given in the July LUMBERMAN, still remain unsolved. The mill men refuse to return to ten hours per day, whilst the mill owners are just as firm in their position that unless the change is made, they will not re-open their mills. One can readily understand, that having been granted nine hours a day last summer, the men do not readily see the point of going back to longer hours this summer. In labor circles this would indicate a retrograde step, as the policy of labor reform is to hold fast to every advance made and press the agitation for something better. But circumstances are not always the same. New Brunswick is near enough to the State of Maine, and the lumber products of the two countries are near enough alike, to bring the one country into competition with the other. In Maine the mill men work from 10 to 12 hours a day. Can New Brunswick hope to meet the competition of Maine with the disadvantage of from 6 to 12 hours labor a week on each man employed? Besides, there is little activity in lumber circles in New Brunswick this year, making the conditions of trade just to that extent unfavorable to them. Deals which a year ago were selling for \$20 a thousand bring only \$14 to \$14.50 now. A drop of this kind is a serious affair to a mill owner. One has said in an interview, that with his firm it would take \$100,000 off the season's business.

What have the mill men to do with this? Not a little. Capital and labor have got to be in sympathetic touch with each other, or else there will ever be discord, and continued loss and worry to both. We take the New Brunswick troubles for the purpose of illustration. Who more than the mill men of New Brunswick are interested in having the mills kept open? This is the source from which they obtain a livelihood? We are told that as a result of the present shut-down, 1,200 men are idle, and wages to the amount of \$21,000 a fortnight are stopped. Are not the mill men affected by these conditions? To many with families depending upon them, it means the difference between comfort and starvation. It means, besides, if the strike is continued for a lengthened period, that every day that a striker is out he is fixing a mortgage on every day's

work of the future, when work is resumed. Do workmen ever consider the extent to which a strike always hypothecates the future? The history of the labor strikes of this continent for a single decade present a record in this respect that is simply appalling.

In saying this much, we have not a word of justification for the monopolist, who would make every man his serf, rather than one with him, in extending his business. Commercial history, sad to say, contains too many blots of this character. But we go back again to the New Brunswick case for illustration. If trade is in such a shape, that it becomes a question with the mill owners, whether they shall curtail expenses, or may be close down business altogether, are not the men, as one of the parties interested, showing the better "horse sense" in lending their aid to keep the mills open? Our strongest sympathies go out with the workingmen in their efforts to improve their conditions, and we believe that every day shows a greater desire on the part of capitalists to help in this direction. Despite even cases like the present the preponderance of facts in the labor world prove that employer and working man are being drawn closer together. But there is no reason why one's sympathies should not be broad enough to cover the capitalist and employer of labor. Has he no troubles? The records of trade tell of too many fortunes wrecked, and whilom capitalists, who in their struggle to keep things going have been obliged at last to give up all, and take a place in the ranks themselves. "It is not all gold that glitters," nor is the man, whose name appears on the sign above some large manufactory, the one who is finding the struggle for existence, the easiest.

The dark ages tell of a life for a life, even among gentlemen of aristocratic blood. Gentlemen do not settle their troubles to-day with an order for "pistols and coffee for two." International difficulties in the past could only be settled at the edge of the sword. Nations arrange their differences to-day around the arbitration board. Strikes and shut-outs only remain a barbarism of the present.

#### CANADIAN BANKING.

THE new Banking Act, which became operative on the 1st July contains several features of importance to the commercial and general public. One of these, and every one is interested here, is the large measure of protection it secures to note holders. Not only must the notes of the bank constitute a first lien on the assets, but each bank is called upon to contribute annually to what is to be known as a redemption fund. Many know from dearly bought experience, that the heavier losers, in the case of a bank failure, comes not unfrequently on those, who cannot afford to hold on for any time to the bills they may have in their possession, and their position being taken advantage of by speculators, they are influenced to dispose of this money at, what is to them, a ruinous sacrifice. It is expected that this redemption fund will be helpful in remedying this evil, as it is to be used, in the case of a bank's insolvency, for the purpose of meeting the notes of the defunct bank within sixty days. Another valuable feature is that all bank issues in Canada are payable at par. It is absurd that a Canadian bank bill should be worth one hundred cents on the dollar in one town, and be subject to a discount in some other town. The provision of the new act, which removes this anomaly, will be welcomed as a piece of common sense legislation. Playing at banking by novices, or starting a "money shop" by unscrupulous money sharks will not be so easy a thing in the future. A quarter of a million of dollars has to be paid in before opening, and no one is eligible as a director of a bank of \$1,000,000 capital or under, unless he has fully \$3,000 of paid-up stock. For a bank of over one million capital a director is obliged to have \$4,000 of fully-paid up stock. Whilst it would be unwise to enact any legislation, that would have a tendency to hamper so important an adjunct to trade, as the banking system of this country, yet from the very direct relationship, that it holds to each individual citizen of the commonwealth, and because so disastrous are the results to the entire community, when a false step is made, too great exactness cannot be insisted on and the people can be depended upon to support all wise legislation in this direction.



# EDITORIAL NOTES

IN ANSWER to an enquiry from Hon. Senator Flint, the Premier, Hon. Mr. Abbott has stated, that in view of the proposed reciprocity negotiations with the American Government in October next, no tariff changes affecting lumber would be introduced at Ottawa this session.

A SUPPLEMENT of the *New York Lumber Trades Journal* has been printed containing a complete account of the contest of the New York lumbermen with the representatives of the trade unions, telling how the fight began, how it was fought and how it was won. It is known to our readers that this fight was the means of paralyzing the lumber trade in the east, just on the opening of the present season. Thanks, however, to the courage of the lumbermen, the fight was of comparatively short duration, and victory was theirs.

A TRIAL in the United States courts has developed the fact that there is considerable wealth embraced in the sunken logs in the logging streams of Michigan. In dragging the Au Sable River for sunken logs, 100,000,000 feet was secured within a very short distance, and now the statement is going the rounds that it is believed there is 150,000,000 feet of logs sunk in the Au Sable alone. These have been calculated at \$6.00 per thousand, which amounts to \$900,000. And the query arises, if this is the wealth at the bottom of one river, how much wealth is lying at the bottom of the various streams, not alone in Michigan, but in logging streams elsewhere as well? An explanation may here be found for the shortage which lumbermen have been unable to account for, when the scale of the boom companies have run hundreds of thousands of feet short of the scale in the woods. As this deficiency never shows itself in logs brought in by rail a strong argument is made for the transporting of logs by rail.

VERY considerable attention is given at the experimental farm in Manitoba to the cultivation of young trees. A recent report says, that millions of native maples are now coming up in one patch. Besides there are 10,000 small elms, which are doing well. The cotton wood from Dakota is hardy and grows very quickly. White birch is doing well and the native spruce trees show an encouraging growth. Some idea of the manner in which the people of the northwest are interested in tree culture is further indicated in the report of Prof. Saunders, of Ottawa, who states that one hundred thousand trees had been secured for these territories, and an announcement was made to this effect. Within five or six weeks after the announcement applications were received covering another hundred thousand. The government have arranged to meet the additional demand. Let this spirit continue and the time is not far remote when the plains of Manitoba and the Northwest will, metaphorically speaking, blossom like the rose.

EXAMINATIONS under the Ontario Cullers Act have been in progress in different sections of the province during the past month. The act provides that no one will be allowed to measure logs cut on the crown domain in Ontario without a government license, and to obtain this license candidates for the position of cullers must first undergo an examination conducted by government examiners. The examination is a written one throughout and consists of twenty-nine questions. (1.) How long have you been engaged in culling and for whom? (2.) How would you measure a log without defects? (3.) How would you measure a defective log? Eleven of the papers had diagrams of logs attached, showing peculiar defects in each. There were a few "catch" questions, two particularly—12 and 18. Number 12 was a diagram of a log thirteen feet long and nineteen inches in diameter, showing seven punk knots on the sides and rotten at both ends. The question

was asked, what would you do with it? and answered, "If I met that fellow in the bush I would not recognize him." No. 18 was, "How should a log thirteen feet long, fourteen inches in diameter at top, and seventeen inches in diameter at the butt, having several case knots on sides, and showing indications of rot at both ends, be treated?" Of course the log was a dead cull. The last paper was making out the culler's return of measurements with affidavit attached.

THE lumber interests of the continent will receive good prominence at the coming world exhibition in Chicago. Canada has received an invitation to make an exhibit and we have no doubt that the lumber section will bear the marks of the enterprise of Canadian lumbermen. We certainly hope so, and will be glad to know that they are already making a movement in this direction. The lumbermen of Washington have promised to contribute all the material necessary for the construction of the building of that State and the Northern Pacific has agreed to transport to the exhibition free of charge. Tulare, California, proposes to furnish a very novel exhibit for the fair. From a gigantic redwood tree, 390 feet high, and 26 feet in diameter, will be cut two lengths forty-five feet long, and these will be transformed into full-sized railway coaches by hollowing out the interior. The rough bark of the tree will be left on the roof and on the sides and ends the natural wood will be left unpolished. The interior will be finished after the style of Pullman cars. One will be a buffet dining car, with bath, barber-shop and kitchen, and the other a sleeper, with observation room. Ordinary car trucks will be put underneath, and the men of Tulare, with their wives and children, will make the trip to Chicago in these strange coaches and live in them while there. The intention is to keep these cars in the exposition grounds, and to sell as mementos the portions of the tree cut away in their construction.

THE sawdust question made itself known at Ottawa this year, though nothing more definite was attained than a promise from the Hon. Mr. Abbott, that next year the government would do something. The question came to the front by Senator Clemow introducing a bill, which proposed to take from the government the power it has at present to exempt any rivers or parts of rivers from the operations of the law against allowing sawdust and other mill refuse to fall into them. The Senator afterwards withdrew the bill on the strength of the promise of the Premier. Hon. Mr. Snowball, the well-known lumber king of the Maritime provinces, placed himself on record in a speech which indicated plainly where he stands on the question. He pointed out that the Miramichi river is one of the most important of the lumbering, as well as of the fishing rivers in the Dominion. Twenty five years ago the local government made such regulations as prevented the mills on that river from throwing their refuse into the water. The regulations were carried out so faithfully on the part of the mill owners that on the main river, where Mr. Snowball stated there are more sawing powers than there are on the Ottawa, there is not one shovelful of sawdust thrown into the river. He deprecated in vigorous terms "the disgrace, that right under the Parliament building, right in the face of the government, this evil has been allowed to exist to the present day," and expressed himself as delighted to hear the Prime Minister say, that action is to be taken in the matter.

AMERICAN lumber exchanges report more than the usual movement of Michigan lumbermen into Canadian pine districts. They are favorably impressed with the conditions for cutting timber in this province, whilst the stumpage with us is cheaper than in their own pine States. Mr. Wm. Ryan, of Brown & Ryan, Saginaw, Mich., is one of the latest visitors to our pine limits, and is likely to make some investments. We suppose there are those who look upon this movement by American investors with a certain measure of dissatisfaction. Why, we hardly know—only that they do so. English gold is to-day largely controlling the manufacturing interests of the United States, and the past year has witnessed a remarkable and increasing influx of British capital into the States. No tangible

reason would seem to exist for the exclusion of foreign capital from any country, and if our American friends see opportunities for investment in Canada, whether in the woods, the mines or commercial pursuits, so long as we have the article to sell, why not sell it? Their greenbacks these days count one hundred cents to the dollar, and our people will lose nothing by the circulation of these in the country. In fact, our merchants are prepared to cross the border with Dominion bank bills, subject to no discount either, and buy those products which conditions in that country make profitable for us to buy. That Chinese wall is the only thing that hits either party.

A DECISION has been given in the case of the Bank of Montreal vs. the J. E. Potts Salt and Lumber Company, of Detroit, Mich. The bank asked the foreclosure of mortgages aggregating \$700,000. This step was opposed by the unsecured creditors, who knew that an adverse decision meant that amount less in assets to be distributed among them. The decision given by Judge Kelly at Detroit on 6th ult., affirms the validity of the mortgages thus leaving the other creditors out in the cold. The common notion has been that an insolvent corporation has no right to distribute the assets, except pro rata among all the creditors. The judge does not do away with this belief, but makes the point that temporary financial inability to tide over a stringent money market or to meet maturing notes without borrowing, is not conclusive evidence of insolvency. In the Potts case he considers that, instead of being in the light of preferred creditors, those who secured mortgages were bona fide creditors. The mortgages, furthermore, did not cover all the property of the corporation. "Until proceedings to dissolve the corporation under the statutes," stated the judge, "or upon sequestration of the corporation assets and appointment of a receiver, the corporation has control of its assets and may sell and mortgage like any individual." The failure of this firm is fresh in the minds of Canadians from the fact that it was supposed to be responsible in a measure for the suspension of the Federal Bank of this city from which a large credit had been obtained.

AT the present time when activity is general among Canadian shingle mills, something may be learned by reference to the work of Mr. Charles Boyden, who ten years ago was the shingle king of the world, and owned a mill at Grand Haven, Mich., with a capacity of 1,000,000 shingles and 50,000 feet of lumber daily. He had his own views of conducting the shingle business, and his own ideas of what should constitute a good shingle. In conversation with a representative of the *Northwestern Lumberman* he once said:—"There are some who see no merit in a shingle unless it is long, clear and thick. I may liken shingle manufacturing to tailoring. One man may want a suit of clothes that cost \$75, but at the same time there are a hundred men who want suits that cost \$15 each. We let the high-priced men buy some where else. We make shingles for the masses. Last year we closed our mill several millions behind on our orders. If there is any man who thinks that a shingle is better for having a played butt, he is, of course, entitled to his opinion. But let me ask you to experiment a little. Take two shingles; with a buck saw cut a piece from across the butt of one of them, and with your knife make the butt of the other smooth and even. Place them side by side in the sun, and the one that is finished so nicely will check an inch or two, while the rough sawed one will not check at all. Then again, go on to an old roof, and notice where the shingles wear out first. The wear is right in front of the lap, and is caused by the water running from the shingle above it. The thicker the shingle the greater the force there is to the water. A shingle with a thin rough butt will outlast a fancy shingle every time, and when on a roof looks just as well from the street." This is the philosophy of only one man, it is true, but of a man who made a conspicuous success of the work he had undertaken. Of late Mr. Boyden has given his attention more particularly to lumbering, being today, president and treasurer of a large lumber company at Neelyville, Mo.



A STATEMENT has been given general circulation in Canadian newspapers, based on a letter to the *Timber Trades Journal*, of London, Eng., from its Ottawa correspondent, saying, that "the shipment of deals from Ottawa to England, is far greater this year than it has been for any previous year." "A Shipper" gives this an emphatic denial. He says the statement is "utterly wrong, reckless and absurd. It is implied that Liverpool takes the Lulk, if not the whole of these magnified shipments. If this correspondent had not cut short his remarks where he did, he might eventually stumbled on something approaching a fact."

I have a letter from a Peterborough lumber firm asking for the latest information relating to the preservation of burnt pine. Canadian lumbermen, of late years, and this year has been no exception, have suffered severely from forest fires. Our American lumbermen have in the past been great sufferers in this respect, and I understand, that some of them have made a study of the question, and are in possession of the best information that is desired by our correspondent. For the general benefit of the craft in Canada, I should be glad to hear from any of our friends.

"With all this talk about the great amounts invested in southern timber by Michigan men," said Walter T. Peale, of Saginaw, Mich., a few days ago, "one would think that our timber was nearly all gone. That is a big mistake. We were so very foolish at the start as to ship a great deal of timber away in the rough, but this is stopped and factories for manufacture of doors, blinds, etc., are increasing wonderfully all over the state. The abolition of the Canadian export duty on logs is already being of great benefit to us. Over 100,000,000 feet of lumber will be sawed in Saginaw this summer. Every year this will increase. We have many years of prosperity before us yet."

"Business is slow," said Mr. Willard W. Brown, the wholesale lumber merchant of Buffalo, N.Y., whom I met a few days ago. "But we look for good trade in the fall. Crops are good. We are just going to have big crops this year. Wheat is looking splendid. Then we send our wheat across the Atlantic, and back comes British gold for it, and things commence to hum. Yes, the New York strike and boycott affected our trade somewhat. I commend the lumbermen of New York for the bold and united front that they showed in this trouble. If they had not acted in this spirit, the boycott might have been in existence to-day. If the men had succeeded they could have gone on and closed every yard in New York. When workmen organize, capital must organize too."

Meeting Mr. R. B. Joyce, a few days since, and knowing that for some years he had been actively identified with the lumber trade of New Brunswick, I queried him in regard to the strike among the mill men of St. John. Said he: "I can remember when eleven and twelve hours was a mill man's day. He would start work at 6 a.m. and keep it up till 6 or 7 p.m., with only the break of an hour for meals. This was simply killing. The work makes too great call on the physical man for even the strongest man to keep this up long. Other employers more considerate would have a break of an hour in the forenoon for a meal, besides the regular dinner hour, which reduced the working hours to ten, rather more reasonable. On the other hand there are and have been cases where the work was kept up until 7 p.m. and a day of twelve hours made up. I know how hard it is for the mill owners to get their money out of their investments on a short working day—at least they think so—when

eleven and twelve hours is the day in Maine. But my own opinion is that the reserve of strength on a nine hour day would be such as to produce more actual work within the week than on the longer day."

To what uses will the products of the forests not be put? I have learned of an hotel in Hamburg built entirely of compressed wood as hard as iron and rendered absolutely proof against both fire and the attacks of insects by subjection to chemical processes. Then what a close relationship is growing up between the wood and paper trades. Sixty-seven cords of poplar is used, for example, to print a single edition of the *Philadelphia Record*—150,000 copies of a twelve page paper. In 22 hours from the time of felling the tree it had been turned into printed papers. A paper averaging 50 cords of poplar daily would consume 18,250 cords annually. In Japan, where the best paper in the world is made, mulberry bark is used. The bark grows on a sort of bush. It is stripped from the young shoots at certain times of the year, just as willow is gotten in this country to make baskets with. The shoots are allowed to grow about three feet long before they are clipped

Where is the man without a sweet tooth—somewhere? Editors possess them, I suppose, like other mortals. The mail clerk of the LUMBERMAN has shown me a letter from an American lumber firm, renewing their subscription to this journal, and adding: "The CANADA LUMBERMAN is a credit to journalism in your country. It is ably edited, and tastily gotten up. We could not do without it in our office." I know of no one who has a better right to sweetmeats than this self same editor. I say eat the candy my friend and relish it. A hearty cheer does every man good in his work. My readers all know the oft told story of the fireman who was ascending a high story to save a child, who was hemmed in by fire and smoke, and must soon have perished. It hardly seemed possible, that the fireman would be able to reach the top of the ladder. He was about giving up in despair. A hearty cheer came from the crowd below. He made one desperate effort inspired by the enthusiasm below, secured the little one and descended safely with her in his arms. The rough places of life with everyone—for who meets not brambles and thistles in his pathway?—is made much the smoother by the heartfelt cheer such as cheered on the fireman to save the little child. These things had far better be given in the present time than in the obituaries that follow after one is consigned "dust to dust, ashes to ashes."

Wonderful finds are not always the most wonderful things in the world. "A wonderful find" always makes a good newspaper item, especially in the "silly season," and the item is often more wonderful than the "find." But there are some good stories extant that can be authenticated sometimes by ones own eyes. The attention of visitors to Toronto has no doubt been attracted by a peculiar "find" that is on exhibition in the emigration offices of the C.P.R., on the corner of York and Front Sts. It will naturally have a special interest to lumbermen, because the "find" was found in a tree—and trees are the stock-in-trade of the lumber business. In one of the windows of these offices will be seen a good sized round of timber sawed from a tree that had its home at one time in the Assiniboine section, near Portage la Prairie. Placed in the heart of this piece is a bone of a buffalo, about eighteen inches in length. How came it there? The tree which was cut down a few years ago, is supposed to have been about 170 years old. The theory is that when a mere sapling, Indian children, who had been playing in the locality, and perhaps had had Buffalo for dinner—aye?—took this bone and set it in a recess in the tree. No more was thought of the affair. The tree grew and grew and the bone was incased in the growth. But in later days, when the woodman had gone forth to slay these giants of the forest, this tree was cut down and the bone discovered. Another good story of interest to the lumber trade comes from Prince Edward Island. Fifty years ago a valuable silver watch was lost by Mr. Holland, the son of Major Holland, well known in the provinces

in those days. A week ago the watch, which was identified by the initials, E. H., on the cover, was found under the roots of a large tree, which had then been chopped down. The watch, I am told, is almost as good as new after its long burial.

The annual period for holidaying has come around and the answer "out of town" meets one more frequently from the business man's office these days than does any other. Going away for the summer has in some cases I believe become a mere fashionable fad. Those who live in the lap of luxury ten months in the year cannot urge, that they must needs spend the other two months in increased luxury, as a means of recuperation from the toils and burdens of the ten months. But my business does not take me among those who spend their days on beds of roses and feed daily with a silver spoon on gold jelly. If there is any lumberman in Canada who finds that he can successfully carry on his business on these lines I want to see him, and I promise him that you shall hear all about him in these pages. No, the business man of the present day has got to have lots of "get up" about him, if his business is to prosper. I am satisfied, that nowhere is the mental tension greater than in mercantile life in the present day. And the more extensive the business man's undertakings, and often the more successful these are, the greater the strain and the heavier the mental burden. "A breaking up of the humdrum of life," as one writer has put it, "and an entire change of life for a couple of weeks once a year is of wonderful benefit to man. It shakes him up, gives him new ideas of life, takes him out of the ruts and delivers him from the charge of becoming a mere machine." I get disappointed in my news gathering, when I find the majority of my clients are summering it, but I know that when I see them on their return, they will fairly bristle with new ideas as an outcome of their summer's outing.

Suggested by an interview in the ELI column of the July LUMBERMAN a New Brunswick reader writes: "I recollect over 50 years ago when ships came from foreign countries into St. John harbor and unloaded their cargo of lumber into British waters and reshipped it and took it to the English market to save the duty they imposed to protect our lumber trade, when our forests were clothed with the most majestic pine and spruce. Sir P. Thompson was at the time sent from England to look into our lumber trade. On his return he recommended the reduction of the duty on foreign lumber and the sons of New Brunswick burned his effigy on the square in St. John. Now our forests are denuded of pine and almost of spruce and the only valuable wood left is our cedar, which is getting slaughtered right and left for shingles; and Americans are allowed to cross our lines and drive it by our mills by the million feet and manufacture it in Maine to save American duty. And O'Leary the great dealer in our short and small spruce, is taking it out of our forests and towing it out of our country in rafts of 3,000,000 ft. at a time; all goes to kill and damn our future lumber trade, all for the want of a protective export duty. Compel the manufacture of our lumber at home and secure our lumber trade for Canadians instead of Americans. Not one stick of lumber should be allowed to leave our shores unmanufactured. Speaking of the Baltic lumber, perhaps it is not generally known that there they haul their lumber in many cases 15 and 20 miles before it is shipped and the wages are less than one shilling per day. Well they may compete under such circumstances, so long as their lumber lasts. We hear considerable blathering about preserving our forests from destruction, and tree planting to meet future demands, but an ounce of prevention is worth a pound of cure. Exact an export duty at once and stop the slaughter of our forests to play into the hands of syndicate lumbermen and give our local mills a chance to secure a few sticks on their streams to saw."

It is estimated that one building at the World's Fair, Chicago, will take 30,000,000 feet of lumber. This will probably be about half of the total consumed by these buildings.

## OTTAWA LETTER.

Conditions of Business—Views of a Leading Lumberman.—Speech by Col. O'Brien M. P. for Muskoka on the Export Duty.—Work of the mills.

[Regular correspondence CANADA LUMBERMAN.]

The general outlook of the lumber trade is, in the opinion of a leading lumberman of the Chaudiere, very satisfactory "For the past year or so business" said he "was very dull and purchasers were slow in buying, but now since there is a stir in the market they will begin to lay in a good stock, especially when it is known that the output of lumber here is to be very small this summer. In my long experience in the business I do not remember any season in which so little lumber was being cut as at present, and the quantity will not likely increase any, as a large number of logs belonging to different firms got stuck in creeks while on the drive, owing to the lowness of the water this spring. It is more than likely, however, that with a good spell of shipping now, the lumbermen will become encouraged and will work their limits heavily next winter, and make the manufacture of lumber lively here next summer. All the shipping accommodation to local points is being eagerly snatched up, and large numbers of men are engaged loading lumber on cars." This opinion is confirmed by the depleted condition of the lumber yards, for never perhaps have they looked so destitute, showing that shipping must have been brisk during the spring.

In the debate on the budget, Col. O'Brien M. P. for Muskoka made a capital speech, dealing largely with the condition of the lumber trade, as a result of present tariff regulations. He took the ground, that whilst certain advantages were obtained by the abolition of the export duty on logs, or rather because of the reduction of the import duty on lumber which followed this step, that yet the general result to the country was most disastrous. He had excellent authority for saying that the export of saw logs during the season will amount to from 80,000,000 to 140,000,000 ft. This means so large a diminution in the employment of labor and capital on our side of the lines, that the country must feel its baneful effects. Further it means a diminution in the production of our forests, so rapid and extensive, that serious consequences in the near future will follow.

Our people are looking forward with eager expectancy to the starting of J. R. Booth's new mill, which will add in a large measure to life around the Chaudiere. Five band saws and the twin circular saws have started, but we wait the buzz of the whole thirteen band saws and the other machinery with which this mill is so splendidly equipped.

Though the E. B. Eddy Co. are rapidly withdrawing from the lumber trade, the well-known energy of this firm is showing itself in other directions and where the product of the forest will be called into use. The old sash factory, of late used as a pulp mill, has been raised one story higher, and a new metallic roof put on. The big saw mill is dismantled, and the mill will be fitted up as another paper factory, though it will likely be January before operations will be commenced, as nearly this time will be needed to put in all the necessary machinery. The workshop in rear of St. John's church is being partly torn down and fitted up as a mill for sawing staves for the pail factory.

Though reports are not very favorable as to the getting out of logs, owing to the low condition of the water, yet a number of the drives are making their way along.

## MINOR MENTION.

Eighteen men of the Egan Lumber Company are also haying along the DesMoines river.

Mill fire wood has been increased 25 cents a load. This will make a difference to Ottawa householders who use mill-wood of \$20,000 per year.

Word has been received here of the death of a well known Ottawa boy named "Jack" Gunnan, who was killed while at work in a Michigan mill.

Mr. J. R. Booth has sent a gang of twenty-five men to his farms on his Upper Black river limit to cut hay for the shanties on that limit next winter.

A lad 12 years of age from Gilmour's mill at Chelsea, stole fifty dollars from a boarding house of that place a short time since. He started for Ottawa, stopped a

night in the Flats, and made away with a watch from a fellow occupant; he next went to Hull and stole a pair of boots; and so far this amateur Jessie James has evaded capture.

Ottawa July 25th, 1891.

## BRITISH COLUMBIA LETTER.

A Big Lumber Deal—English Capital on the Coast.

## A Budget of News Notes.

[Regular correspondence CANADA LUMBERMAN.]

The transfer of the Moodyville Saw Mill Company to an English syndicate to be known as the Moodyville Land and Saw Mill Company has finally taken place. The money has been paid over and the new owners are in possession. The transaction amounts in value to about one million dollars, and is probably the most important which has occurred in the commercial history of Vancouver. The board of directors is a very influential one, comprising the following noblemen and gentlemen: The Earl of Chesterfield, the Earl of Durham, Mr. Arthur Heywood Lonsdale, Colonel, the Hon. Oliver Montague and Mr. Edmund Evan-Thomas. Messrs. Wulffsohn & Bewicke, (Limited), will be the general agents in British Columbia, and Mr. Johann Wulffsohn of that firm the general manager of the company.

The property acquired by the new company is a very extensive and valuable one, including large and valuable tracts of land besides that embraced in the mill property itself. On the north shore of the Inlet, surrounding the mill, there is 1,786 acres, with a valuable water frontage of three miles. Other valuable agricultural lands are situated at Mud Bay, Strainer Island in the Coast District and elsewhere, aggregating 9,384 acres. There are also no less than 31,448 acres of valuable timber limits included in the purchase. The local management of the mill and the general conduct of the business will be the same as at present, the results of the operation of the business having given results that show this policy to be in accord with the interests of the concern. The successful completion of the negotiation by Mr. Wulffsohn cannot fail to be of great advantage to Vancouver.

## A BUDGET OF NEWS MATTER.

The construction of the Nicaragua Canal is expected to consume considerable lumber from Puget Sound and B. C. ports.

A new industry, the British Columbia Paper Manufacturing Co. have decided to locate at Alberni, on Vancouver Island.

No bush fires of a destructive nature are reported yet and as the summer is advancing very little damage will likely be done by them this year.

The Canadian Pacific Lumber Co.'s new wharf on Lulu Island is nearly completed. Their portable mill is ready and soon will be cutting for the main mill.

The Vancouver Manufacturing and Trading Co. are building a dry kiln 40x35 feet. They have lately added a boiler house and put in a new Corliss engine. The mill will be taxed to its fullest capacity when it starts again.

The Taylor Mill Co., Lt'd, have very much increased their output of lumber, sashes, doors, and everything in the building line. This is the concern that took over the plant and buildings of the Queen City Planing Mills, Victoria.

During the month the long expected ship *Duke of Argyle* arrived safely, discharged her cargo and went to Astoria, on the Columbia river, to load wheat for Great Britain. The *Lanarkshire*, *Morayshire*, *Noddleburn* and *Rothsav Bay* are expected now.

The *Louisa Marta* has completed loading for Sydney, at MacLaren-Ross Lumber Co.'s mill. The *Leonor* will finish for Melbourne by the 18th inst. This is the first work the mill has done and gave the greatest satisfaction. Not a hitch occurred and all the machinery worked smoothly.

All the mills continue taxed to their fullest capacity to fill orders. The Brunette Saw Mill Co. and B. C. Mills F. & F. Co. ship from three to five car loads daily to the Northwest, Manitoba and Ontario. The shingle

mills are all increasing their outputs and shipping largely to Manitoba and the Northwest.

The representative of a large lumber firm in Adelaide, Australia, is now here for the purpose of arranging for a line of lumber steamers between British Columbia and Australia. The *Remus* and *Eton* have been chartered, but another is wanted. This is a most important matter for the lumber trade in British Columbia and it is to be hoped the venture will be successful.

H. G. R.

New Westminster, B.C., July 25, 1891.

## VIEWS AND INTERVIEWS.

Sweden has an area of 170,900 square miles, 65,000 of which is timber lands.

One of the interesting objects which will be exhibited at the World's Fair is a table, made from the timber of the house in Funchal, Madeira, in which Columbus lived for a time before he began his voyages of discovery.

The average annual time of employment for mill hands, according to the United States census report, is 7.11 months in Michigan, 6.43 months in Wisconsin and 5.72 months in Minnesota. Has the climate anything to do with making this result as shown?

Practical lumbermen who have visited Mexico say those great forests of mahogany and other woods fail to materialize. Others, who made efforts to build up a trade in South American woods, tell how the difficulties of getting the really valuable timbers out of the impenetrable wood, almost, if not quite, overcome all advantages.

It is worthy the attention of Canadian lumbermen that the output of North Carolina pine during this year is expected to be about five hundred millions of feet, estimated as worth \$6,000,000. In addition to this the production of cedar, poplar, cypress, holly, ash and gum is valued at about four and one-quarter millions of dollars.

Mr. Wolfred Nelson, who is writing a series of papers in the *Montreal Gazette* on commerce with Jamaica, gives a deal of valuable information relative to the conditions of trade with this country. Touching the subject of lumber he tells us that there is a steady demand in Jamaica for Canadian white pine, which is everywhere to be seen there, but that it was purchased in New York through middlemen. Very naturally Mr. Nelson asks, why not reach the Kingston market direct? The spruce of the Maritime provinces is almost useless in any hot climate, as wood borers soon reduce it to a perfect honeycomb. "In fact any wood that holds its sap is only food for the many voracious and destructive insects that infest the tropics." There were shipped from the Maritime provinces last year to the British West Indies \$150,000 worth of planks, boards, joists and scantling, "while Jamaica alone imports over five million (5,000,000) feet of white pine, almost every foot of which comes from New York. All this can be changed if Canadian lumbermen wish, and Canadian vessels could easily secure return cargoes of sugar, fruit, dye woods, etc. It awaits Canada."

The notable suit of Simpson Rennie v. the Utterson Lumber Company will go to the Supreme Court. The defendants are not discouraged because already twice beaten, but are prepared to put up security for costs to carry the case to the Supreme Court. The facts are as follows: Some years ago Simpson Rennie, who is a Scarborough farmer, loaned \$4,000 to two men who were running a saw mill on the shores of Mary's Lake. Rennie took a mortgage, as he supposed, on the mill property and adjoining lots. The mill men assigned subsequently to R. H. Gray, Toronto. At this stage the Utterson Lumber Company was formed by J. W. Lang, Ald. W. W. Park, Wm. A. Mitchell, of Toronto, and other men. They bought out the mill, and ever since have been endeavoring to establish the fact that Simpson Rennie's mortgage did not apply to the mill, but only to the adjoining land. The mill is built on piles in the lake and no part of the building proper touches the land, which facts were not made clear in the mortgage. Nearly two years ago Mr. Justice Falconbridge gave judgment in favor of the plaintiff, and lately the Court of Appeal sustained this decision.



## THE NEWS.

## ONTARIO.

—J. H. Sharp, saw mill, Sudbury, has assigned.

—James Bateman, planing mill, Toronto, is dead.

—Delaney has 30,000 logs stuck in the Spanish river.

—The big saw mill at Burk's Falls, is again running.

—M. L. Killam, lumber, Scotch Settlement, has failed.

—W. F. Kay is operating a portable saw mill at Otterville.

—The saw mill of the late J. W. Brisly, Flesherton, is to be sold.

—Shaw's new shingle mill at Novar will soon be in operation.

—Mr. Grenside, Mitchell, is to start a saw mill in Mount Forest.

—The saw mill at Cheesville is running full time and trade is good.

—Thos. Hissock, a speculative builder of this, city has assigned.

—Malins & Carter contemplate the erection of a saw mill at Burgessville.

—Thomas Rosewames mill at Cottom is in charge of Mr. Robert Quinn.

—McKechnie & Co., will put new machinery into their mill at Glenroaden.

—Wm. Willis & Co., lumber, London, have sold out; firm now Willis & Kernohan.

—Hurdman & Co's mill at Ottawa which had ceased work for want of logs is running again.

—The mill at Thompsonville, which has been undergoing repairs, is now in running shape.

—Orr Brothers, of Maidstone, are shipping lumber in considerable quantities to Detroit, Mich.

—A sneak thief stole \$46 from the till of the Masson timber mill at Hintonburg a few days ago.

—The P. S. L. Co.'s mill at Parry Sound, which has been shut down for some time, has again started.

—Shipping is fairly brisk at Parry Sound, the lumber interests contributing a good share to the trade.

—It is said that an Ottawa contractor has bought all the slabs from the mills and will form a corner in wood.

—Wm. Emery, of the Emery Lumber Co., Wahnipitae, was fined \$10 and costs for taking moose out of season.

—A Stratford lumber dealer, by name, F. S. Miller, has levanted, leaving private banker Kane, of Gorrie, \$265 short.

—One of the Howry camps at Little Current, has disbanded for the meantime. The firm intend to start in the woods in August.

—Eight million feet of logs from this province will, it is said, be received by the Detroit mill at Bay City, Mich, this season.

—James Shand, of Creemore, has sold his foundry to Hawkins Bros., of Sundridge, and taken a saw mill at Eagle Lake as part pay.

—Mr. Charles Bell, of Colchester south, has traded his saw mill and \$1,000 cash for a 60 acre farm, the property of Mr. John Larabee.

—A lot of trucks and chains seized from the Essex Land & Timber Company for undervaluation, have been sold by the custom's authorities.

—An old lumberman down from the Kippewa states that the water in that tributary of the Ottawa is only falling an inch a day at present.

—W. P. Widdifield and C. Dike, mill owners of Port Perry, have been fined \$26, for allowing saw dust to have gathered in the stream at Siloam.

—Thistle, Carswell & Mackay have got their full stock of logs down the Constant Creek and Black Donald. They will cut about 65,000 logs this year.

—A man named Celestier Pleref, an employee on E. Moore's raft, Pembroke, has been committed to jail to await trial for house breaking on 19th ult.

—All the engines, boilers, machinery, waterpipes, hydrants, etc., from Gilmore's mills, Ottawa, have been purchased and removed by Law Bros. & Co.

—The logs of the Dickson Company, of Peterboro', have come through all right and will be cut at the Company's mills at Lakefield, Harwood and Peterborough.

—The drive of the Rathbun Co., Deseronto, has been a difficult one to move owing to low waters. One hundred and

seventy-five men were employed in bringing it down. With energetic work however, it has at last reached its destination.

—Mr. Playfair, whose mill was recently destroyed by fire at Sturgeon Bay will cut out his stock this year at the Ontario Lumber Co.'s mill at Dollarville, Midland.

—Donald Martin of Flesherton, has contracted for the cutting of over a million shingles for the Messrs. Tanner, of Sturgeon Bay. His sawyer is Mr. Joel Smith.

—R. Arnel, with a gang of men is driving pulpwood at Iron Bridge, Algoma. The water in the river is lower than it has been for some years, making driving hard work.

—The new saw mill at Thessalon, erected by S. Maguire, is nearly ready to commence operations. It will cut the logs taken out last winter for the Sault canal contractors.

—Five of the Rathbun Company's men at their yard in Gananoque took from the dock and stowed on a steam barge 24,500 feet of lumber in 24 minutes and 10 seconds.

—The Windsor Planing Mill Company is in financial difficulties. The business will be wound up, and Mr. James Campean, one of the firm, will return to Amherstburg.

—A large steam barge loaded with paper wood taken out of the woods last winter, has been anchored at Thessalon. The wood, it is said, will be taken to Detroit and Cleveland.

—The Casselman Lumber Co., of Casselman, state that their loss by the recent fire will be \$60,000 over insurance. They have bought a mill across the river and have commenced work.

—The Detroit Sulphur and Fibre Works are taking out pulp wood in large quantities from the Algoma section. Before the season is over they will have expended about \$30,000 in and around Thessalon, the centre of their operations.

—Stave works are to be added to the Buchanan mill at Staples. This will make four stave manufactories in the village. The Old Company mill of this place has changed hands, and is to be remodelled with a hoop and stave apparatus added.

—Sibley & Beringer, the Michigan lumbermen, are working away at 11,000,000 feet of logs which are hung up in the Spanish river. They hope to get them down, but the water in the stream is said to be at a lower stage than ever before known.

—The partnership heretofore existing between W. P. Keiran, Samuel McAdam and Andrew Shannon, all of the city of Toronto, Ontario, carrying on business under the firm name of "The Shannon Shingle Manufacturing Company" has been dissolved by mutual consent.

—A man named William Howe, who has been engaged by Loper and Rumley, lumbermen in the logging camps on Battle Lake, about 25 miles from Big Forks, reports that the crops on the Rainy river are looking well and the settlers are happy and contented. The country is well watered and timbered and easily cleared for settlement.

—It is doubtful, says the Lindsay Post, if there is a mill of its size in the whole Midland district that turns out as large a quantity and as varied a list of products as does Rathbun & Co.'s little mill at the lower wharf. The average daily output is 800 tamarac, hemlock and cedar ties, 20,680 of shingles, 4,000 ft. of lumber, 4,000 lath and 3,000 feet of square timber.

—A man representing himself as from British Columbia engaged over 100 workmen at good wages among the mill hands at Ottawa to go west. He collected \$1 from each as a guarantee they would turn up at the railway depot. The men turned up, after losing their jobs, at the station, but the man who had engaged them had decamped with the funds he collected. Those who had no money gave him their watches.

—Royal assent has been given to an Act of Parliament granting power to the "E. B. Eddy Manufacturing Co. of Hull, P. Q.," to change their name to "The E. B. Eddy Co. Ltd." President Eddy, in a circular to his correspondents, hopes that the trade relations, extending in some cases over forty years, may be continued and increased. A branch establishment has been opened in Toronto, in charge of Mr. Weldon.

—A wood pulp mill and paper factory on a large scale is to be built by an American company on the Niagara river, presumably using the power of the waters at the Falls. General Sooy Smith, who will draw the plans for the buildings, says that the company intends putting in a plant that will cost \$500,000. The company has leased sixteen acres of land from the Niagara Tunnel Company. It appears that John L. Newton is at the head of company, and Mr. Hall, of Sault Ste. Marie, who owns one of the largest spruce forests in America is a member.

## QUEBEC.

—Lumber shipping by barge is reported dull in Quebec.

—The mills at Magog have been shut down for a few weeks for repairs.

—A demand of assignment has been made upon Daniel Riopel, a Montreal builder, who owes \$15,582, of which \$13,000 is secured by mortgage, the Jesuit fathers being interested to the extent of \$5,000.

—A number of American families will be brought into Hull from Massachusetts, by the E. B. Eddy manufacturing company, to operate their large paper mills. There is a rumor afloat that the company are considering the advisability of purchasing a parcel of land adjoining Eddyville.

## NEW BRUNSWICK AND NOVA SCOTIA.

—The Misener mill at Edgar, Colchester north, N. S., is again running, Mr. Misener having made fresh purchases of logs which are being trucked to the mill.

—The new saw mill at Burlington, N. S., the property of Messrs. F. A. Clark & Sons, is doing a lively trade, considerable lumber being shipped to Boston.

—One gang in Gibson's lumber mill at Marysville, N. B., cut 87,183 feet of deals on a recent Saturday. This is claimed to be the largest day's cut ever done in the province. The logs were taken as they came.

—The Leary raft of logs which left St. John, N. B. on June 28th, in tow, reached Long Island, N.Y. on 15th ult. The raft is 4,000 feet long from the tugs to the end of the raft and contained about 3,500,000 feet of lumber. The rafts are differently constructed to those of a year ago. The cribs are sixteen in number.

—Lower Stewisacke is one of the flourishing villages of Nova Scotia. Lumbering operations are conducted on an extensive scale. Alfred Dickie's mill has cut 3,500,000 feet of lumber since last summer. Mr. Dickie's mill was completely destroyed by fire a year ago, but he immediately rebuilt and has a thoroughly equipped mill for the productions in all shapes. Fifty hands are employed. In the winter season some seventy to eighty hands and about thirty horses are employed in the woods getting out logs. In addition to Mr. Dickie's work, large lumbering operations are carried on by Jacob Harvey and Messrs. A. Bigelow & Sons.

—The shipment of spruce deals, etc. from St. John to the United Kingdom and the European continent to June 30, '91, compared with shipment for half of the previous year was as follows: The total was 59,359,941 feet of deals, which is 8,600,000 feet more than in the previous time.

Ports.	1891.	1890.	Beh. tons.	Pine. tons.
	Deals, S. ft.	Deals, S. ft.		
Liverpool . . . . .	21,501,810	15,018,403	2,596	681
Bristol Channel . . . . .	19,287,513	16,669,074	187	..
Ireland . . . . .	9,889,546	8,526,466	..	..
Fleetwood . . . . .	2,239,225	5,889,726	..	..
Continent . . . . .	4,593,637	1,801,792	..	..
Other ports . . . . .	1,848,210	2,843,406	..	..
Total . . . . .	59,359,941	50,748,867	2,783	681

Besides these deals there was shipped 2,678 tons birch timber and 1,228 tons pine timber, during 1891, where in 1890, same time, 2,783 tons birch and 681 tons pine was shipped. The largest shippers were M. M. Mackay, Alex. Gibson and George McKean.

## MANITOBA.

—D. Brundrit, lumber, Balder, is moving to Melita.

—A saw and planing mill will be erected at Lockington.

—Lumber mills at Rat Portage are doing a good summer's business.

—Mr. Chaloner, of Rat Portage will open a lumber yard at Napinka.

—The Brandon saw mill have a gang of thirty men at work on their drive of logs.

—The Northwestern, Ontario & Manitoba lumber association excursion by steamer from Rat Portage to Rainy River on the 22 ult.

—Cameron & Kennedy's mill at Norman, is again running having received a tow of 10,000 logs.

—Rutherford & Co., of Stonewall, are putting in a saw, boiler and engine and increasing the capacity of their mill.

—There is a jam of logs at the Assiniboine bridge, about three miles north-east of Virden. They extend back for a mile and a half, some places three feet deep. They are owned by Mr. Christie, of Brandon.

—J. Hanbury, of Brandon talks of converting his planing mill business into a large joint stock company with a capital stock of \$100,000 for the purpose of doing all kinds of sash and door manufacturing.

—Work has been commenced with a large force of men on what is termed the Rainy river extension of the Duluth & Winnipeg, but which is in fact the new logging railway of the Itasca Lumber company, of Minneapolis. The point of junction is at Bass brook, six miles west of Grand Rapids, Mich., and the road as now projected and in process of construction will tap an exceptionally fine tract of timber belonging to the Akeley and Itasca companies.

—A. H. VanEtten, lumber dealer, Winnipeg, is in trouble and his stock has been sold by the sheriff, bringing 60 cents on the dollar. There is likely to be some further litigation over the matter. Judgment was confessed in favor of the Western Lumber Company, and other creditors propose contesting the case. Lake of the Woods mills are mainly interested. Liabilities are largely in excess of the stock, which is estimated at about \$4,000, but book accounts amount to considerable.

#### BRITISH COLUMBIA.

- A saw mill is to be erected at Mission.
- D. F. Adams has established a lumber yard at Victoria.
- Ward's shingle mill on the North Arm is doing a large trade.
- The Slater shingle mill at Vancouver has been purchased by H. H. Spicer.
- Another saw and planing mill is to be started at Chilliwack at an early date.
- A shingle machine has been placed in the mill of McLaren & Co., Edinburgh.
- The McLaren-Ross Lumber Company are carrying on logging on an extensive scale.
- The mill at Nanaimo is unable to supply sufficient lumber to meet the demand there.
- A \$75,000 saw mill is going up on the New Saanich town site, near the Bretbour property.
- The mills at Chilliwack are taxed to their utmost capacity in supplying the local trade.
- A new saw and door factory is being erected at New Westminster by J. Galbraith & Sons.
- The barque *Leonor* will leave New Westminster for Australia shortly with a load of lumber.
- Alderman De Pencier, of Vancouver, intends going into the lumber business near New Westminster.
- The British ship *Leading Wind* will sail from Vancouver for Melbourne, Australia, with lumber, early this month.
- The steamship *Zambesi* left Victoria on the 10th ult., with a shipment of 700,000 feet of lumber for Japan and China.
- A company is being formed in British Columbia to build a fleet of large lumber ships to ply between that country and China and Australia.
- Richardson and Heathorn, Victoria, are no longer interested in the West Bay Saw Mill Co., which is now owned by the estate of Wm. Heathorn.
- A. McLaughlin is surveying new limits near New Westminster. On his return, arrangements will be made to start a number of new logging camps.
- A sale of 160 acres of the government reserve on Burrard Inlet, took place on 15th ult. The property is known as part of the Moodyville Saw Mill Co.'s timber limit.
- A week since, the Hastings mill at New Westminster, made the largest run in their history, namely 165,000 feet and for some time past it has averaged 150,000 feet per day.
- W. L. Tait & Son's shingle factory on False Creek, near Vancouver, employs 18 men and manufactures about 80,000 shingles per day. They find a ready market in the Northwest.
- Another new mill is being erected at New Westminster, under the direction of Mr. Wilson, formerly millwright for the Brunette Saw mill Co. It is expected to be ready for operation by Oct. 1.
- The Canadian Pacific Timber and Lumber Company have commenced driving piles for their new mills on Lulu Island, Fraser river, near New Westminster. The building of the mill will be pushed ahead with all possible despatch.
- L. Geo. Brown, for many years engaged in the export timber business in the Phillipine Islands, has been holidaying in Vancouver. From thence he returns to London, Eng. His business in the east, which he conducted for 27 years, he has sold to Smith, Bell & Co. of Hong Kong.
- The new mill at Chemainus, the property of the Victoria Lumbering and Manufacturing Co., has started work. The machinery used is of the latest and most improved pattern, and capable of cutting 250,000 per day when running at full blast.

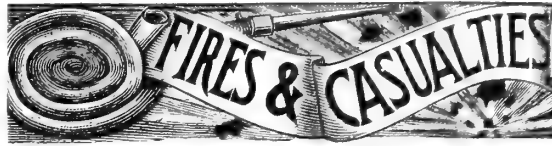

#### FIRES.

- Trigger's mill, West Lorne, Ont., was injured by fire on 14th ult.
- The steam saw mill of H. Ross & Co., Orford, Ont., is an entire loss by fire.
- J. H. Larkin's saw mill at Terranora, was consumed by fire a few weeks ago.
- Great devastation is being caused by fires along the valley of the Madawaska, Ont.
- Hitchcock & Foster will suffer severely by the bush fires on Cockburn Island, Algoma, Ont.
- The shingle mill of A. Van, of Foxmead, Ont., has been destroyed by fire. Loss, \$1,500.
- The Imperial Lumber Company are heavy losers through bush fires in the vicinity of Warren, Ont.
- Thos. Kinread, door and sash factory, Moncton, N. B., was burned out; loss about \$2,500; no insurance.
- The Rathbun Company had 12,000 feet of lumber on Queen's Wharf, this city, burned on 24th ult. Loss, \$400. Insured.
- Great bush fires have been raging around Bark Lake, Ont., in North Hastings and much damage has been done to timber limits.
- The Pettit Bros.' mills four miles from Comber, Ont., have been destroyed by fire. Loss, \$12,000. Insurance, \$4,000.
- Archer & Co., lumber dealers, of Quebec, Que., lost \$10,000 to \$15,000, by the destruction of their lumber yard by fire on the 10th ult.
- Bush fires have been doing considerable damage in the Lake Superior region. Near Fort William there was danger at one time to outlying buildings.
- Forest fires are raging everywhere on the North Shore. Advices from Cockburn Island point to the entire destruction of all standing timber. The loss will run up into hundreds of thousands. Indians are blamed. White people are also very careless.
- Montreal, Que., had a big blaze on 13th ult, resulting in the destruction of the lumber yards and sash factory of Charles Brouillette & Co., St. Catherine St; Roberts & Co.'s lumber yards and the property of Prefontaine, lumber and building supplies.
- The extensive mill plant of Mitchell Bros., at Jennings, twelve miles north of Cadillac, Michigan, was burned. Eighteen million feet of lumber, the big planing mill and eight dwellings were destroyed, involving a loss of over \$200,000. The property was insured for \$150,000.
- The fire on the Pembroke limits, Pembroke, Ont., has almost spent itself. A fire is raging on the old Capt. Findlay limits on Black River, now owned by Mr. Booth. A tremendous fire is raging on the Temiscamingue Government limits, and Bush Ranger, P. McLaugherty, has taken down a gang of men to fight the fire. A fire started in Mr. W. Inglee's bush just outside the town.
- The extensive saw mill of the Georgian Bay Consolidated Lumber Company, Byng Inlet, Ont., was completely destroyed by fire on the 3rd ult. The loss is about \$85,000. The following is a list of insurances: On the saw mill—Etna, \$2,500; British America, \$2,500; Mercantile, \$2,500; Royal Canadian, \$2,500; Hartford, \$2,500; Phoenix of England, \$2,500; Scottish, \$4,000; Liverpool, London & Globe, \$5,000; London & Lancashire, \$5,000; Western, \$5,000. On stores and stock—Royal, \$1,000; Manchester, \$2,000; Etna, \$3,500; Western, \$2,500; Lancashire, \$3,000. On tramways—Royal Canadian, \$5,000. On storehouse—Lancashire, \$1,000; Etna, \$1,500; Western, \$1,500. On lumber—Etna, \$5,000; Manchester, \$4,000; Phoenix of Brooklyn, \$4,000; Western, \$5,000; London Association, \$2,500.

#### CASUALTIES.

- Alex. Young, of Essex, Ont., fell from a load of logs and was seriously injured.
- A. E. Armstrong lost the fingers of his right hand in a planing mill at Peterborough.
- A lumberman at Bickly Bay, B. C., had two ribs broken and was otherwise bruised by a falling tree.

A lad fourteen years old, named Vance, had his face horribly mangled in Ryckman's planing, Waterdown, Ont.

Mr. John S. ... Sturgeon's Falls, Ont., by a stick of timber falling on it.

A man named Bertrand had his fingers smashed a few days ago while at work in Eddy's pail factory, Hill, Q.

A despatch from Manitoulin Island, Ont., says that W. C. Latham, of Providence Bay, was killed while sliding.

A tree fell on Joseph Hopkins, of Vancouver, B. C., breaking one of his legs. He was connected with Tyler's logging camp.

Thomas White, a workman engaged in the Moodyville Saw Mill, B. C., had the end of one of his fingers crushed by a roller.

John Kingswood, an employee of Still's factory, St. Thomas, Ont., had his hand badly lacerated by a circular saw on 13th ult.

Recently, while giving directions in his factory, Mr. Schell, of Alexandria, Ont., had his left hand caught in the planing machine and lost two of his fingers.

A raftman named Ferdinand Fournier, was drowned in the rapids of Lake Deschenes, on the Ottawa, in attempting to spring from one crib to another.

Chas. Coch, an employee of the Union Furniture Co., Bass River, N. S., had his left hand badly cut in a circular saw in their factory, a week since.

William Walder, the head sawyer at Leary's saw mill, Whitechurch, Ont., had several arteries of the left arm severed by falling on a newly sharpened saw.

A young man named Thomas Nicholson, while working in the sash and door factory at Haslem's saw mill, Nanaimo, B. C., had his arm nearly cut off below the elbow.

On the 8th ult., Mr. Chas. Hebb had three fingers of his right hand taken off by a circular saw, while working in the steam mill of Mr. Alex. Nelson, Bridgewater, N.S.

A young man named Charibois, an employee of the Georgian Bay Co.'s saw mill at the mouth of the Severn, went out in a canoe on Sunday 19th, and upset and was drowned.

Wm. Parker, of Sundridge, Ont., met with a painful accident during the month, being struck on the head with the fragment of a large pulley, which went to pieces in Dunbar's mill.

John Chambers, employed in Senkpeil & Hauser's broom handle factory, Elmwood, Ont., was struck in the stomach on the 17th ult., by a piece of board thrown by the circular saw and died from the effects.

Theophile Carriere, an employee of Ross Bros., Buckingham, Que., was drowned a week since, owing to the bank of the river giving way, while he and a gang of men were busy excavating for foundations for a new slide. Five others narrowly escaped.

A logger named Thomas Michand, in the employ of the Hastings Saw Mill Co., Vancouver, B. C. was killed in the woods on Valdez Island, a few days ago, by a falling tree. His head was crushed into a pulp and death was instantaneous.

A promising young man, named Jas. Malone, of Parry Sound, Ont., lost his life on the Sequin River, a week ago. He was working on Wilder's drive and took a step forward to get on the capstan crib within reach of him, when his foot slipped on the driftwood and he fell heavily on his side on a pin which stuck up at the corner of the crib, receiving injuries from which he died in a few hours.

Mr. George Gordon, of the Deseronto, Ont., machine shops, was the victim of a serious accident on 6th ult. He was engaged putting up a Sturtevant steam heater at the Napanee Cement Works, Napanee Mills, when suddenly it fell, crushing him beneath its weight. Though the injuries are severe, they are not likely to prove fatal.

—The British Columbia Iron Works are now engaged building a logging engine for Mr. J. M. Stewart's logging camp on the North Arm of the Inlet. It is of an American pattern, the first of the kind ever made or used in British Columbia and will be of 75 nominal horse power.

—A small saw mill is being erected at Tulameen for the Tulameen Gold and Platinum Mining Co. The mill will be erected on the property of the company, and there used for cutting timber for the flumes and sluices used in hydraulic mining. The company expects to be washing out the gold and platinum in a few weeks, and from last reports the shareholders are more sanguine than ever of rich returns. The headquarters of the company are at New Westminster.

TRADE REVIEW.

Office of CANADA LUMBERMAN, July 31, 1891. THE GENERAL SURVEY.

REPORTS from the leading centres of the lumber trade, both in our own Dominion, the United States, and from over the sea, do not tell of anything remarkably active or momentous.

Local trade, speaking for the moment of our own city, is quiet. Building operations on the larger scale are active. Seldom in the history of the city have so many contracts for buildings of an extensive character been in active movement all at one time, as is the case this year.

If things are slow in the city, no different tale can be told of the country. In Western Ontario trade is unquestionably quiet. But there is good reason for this in country trade everywhere, for the farmers are busy harvesting a grain crop, that will undoubtedly be the largest and finest that Canada has seen for many years, and this means good business in the fall.

A considerable business in Canadian lumber is being developed with New York city and other American points, that had not been done before, and the trade have reason to expect that these new openings will continue to grow and broaden.

In New Brunswick trade has been woefully disturbed by the strike among the mills of St. John, and which at this writing shows no indication of a speedy termination. This is more than unfortunate, for no too great activity in lumber has prevailed in this province for some time.

It can hardly be said that the same life in lumbering is a distinguishing feature of British Columbia trade, as was the case some months ago. The loss of the South America trade, because of the internal troubles of that country, has curtailed the market to no inconsiderable extent.

UNITED STATES.

The special information, which we are enabled to furnish in connection with the quotations of prices current at the principal lumber points of the United States, show that nowhere at present is business rushing. Lumbermen are seemingly resting on their oars,

holidaying in many instances—waiting for the future. Business circles almost everywhere have felt, either directly or indirectly, the failure of S. R. Howell & Co, who conducted business on a gigantic scale at Chicago, Omaha and Atchison. The liabilities reach within a fraction of \$2,000,000. The failure is said to be a very rank one.

FOREIGN.

The tendency of the English market is to lessened trade. Says the Lumber Trades Journal, of London, Eng: "London shows a marked decrease for the five months compared with 1890; Liverpool keeps fairly animate, but the other great depots, more or less, betray a lassitude of business that does not argue well for a heavy import.

France, it is thought, has finally adjusted the duties on wood imports. These will be 65 centimes to 1 franc on timber and sawn goods above 35 millimetres in thickness, and 2 to 3 francs on sawn wood 35 millimetres and under, all per hundred kilogrammes.

Toronto, Ont.

CAR OR CARGO LOTS.

Table listing lumber prices in Toronto, Ont. for July 31, 1891. Includes items like 1 & 1 1/2 in. Cut up and better, 1X10 & 12 dressing and better, etc.

YARD QUOTATIONS.

Table listing yard quotations for lumber in Toronto, Ont. Includes items like Mill cull boards & scantling, Shipping cull boards, Scantling & joist, etc.

Ottawa, Ont.

OTTAWA, July 31, 1891.

Table listing lumber prices in Ottawa, Ont. Includes items like Pine, 1st qual., Pine 4th qual., shipping culls, Laths, etc.

Montreal, Que.

MONTREAL, July 31, 1891.

Table listing lumber prices in Montreal, Que. Includes items like Pine, 1st qual., Pine shipping culls, Pine, 4th quality, Spruce, per M., Hemlock, timber, Ash, Basswood, Oak, Walnut, Cherry, Butternut, Birch, Spruce timber, Hard Maple, 1 1/2 Lath, Shingles, 1st, per M, Shingles, 2nd, etc.

St. John, N. B.

ST. JOHN, July 31, 1891.

Table listing lumber prices in St. John, N. B. Includes items like Spruce deals, Pine, Deal ends, Scantling, Shingles, Clapboards, Spruce, extra, Pine, No. 1, No. 2, etc.

Table listing various lumber products and prices, including Flooring, Dressed, Miscellaneous, Staves, Heading, etc.

New York City

NEW YORK, July 31.—A certain measure of summer quietude marks trade this month. Lumbermen and their customers, both, are doing as much holidaying just now as anything else. The bumptious dealer is found here, as well as elsewhere, and he tells you he is doing big things, but a general survey finds trade no more than fair to middling.

White Pine—Western Grades.

Table listing prices for White Pine—Western Grades, including items like Uppers, 1 in., 1 1/2 & 2 in., 3 & 4 in., etc.

Saginaw, Mich.

SAGINAW, MICH, July 31.—Buyers are few and far between this month. The docks contain abundance of lumber, but there it rests for the present. Emery Bros. are reported to have made a sale of 2,000,000 feet to go east.

Finishing Lumber—Rough.

Table listing prices for Finishing Lumber—Rough, including items like Uppers, 1, 1 1/2 and 1 3/4 in., Selects, 1 in., 1 1/2 & 1 3/4 in., etc.

Siding.

Table listing prices for Siding, including items like Clear, 1 1/2 in., 1/2 in., Select, 1 1/2 in., 1/2 in., etc.

Timber, Joist and Scantling.

Table listing prices for Timber, Joist and Scantling, including items like 2X4 to 10X10, 12, 14 and 16 ft, etc.

Shingles.

Table listing prices for Shingles, including items like XXX 18 in. Climax, XXX Saginaw, XX Climax, 18 in 4 in c. b., etc.

Lath.

Table listing prices for Lath, including items like Lath, No. 1 white pine, Lath No. 2 W. pine Norway, etc.

Albany, N. Y.

ALBANY, N. Y., July 31.—No life in lumber exists at this point at present. Trade is very quiet, and orders are light. We are holding sufficient stocks for all demands, and in pine, the stocks on hand far exceed the demand.

White Pine.

Table listing prices for White Pine, including items like 1 to 2 in. good, 1 1/2 to 2 in. box, 1 1/2 to 2 in., 4ths, selects, pickings, etc.

Thirteen Foot Stack Boards and Plank.

Table listing prices for Thirteen Foot Stack Boards and Plank, including items like 1X10 in., up dressing, 1X10 common, 1X12 dressing, etc.

Shingles and Lath.

Table listing prices for Shingles and Lath, including items like Shingles, shaved pine, 2d quality, Sawed, extra, Sawed, clear butts, Cedar, etc.



Buffalo and Tonawanda, N. Y.

TONAWANDA, N.Y. July 31.—We are looking for a fairly lively trade during August, but throughout July the market has been featureless. We certainly hope for the anticipated improvement, for a long continued siege of quietude in so important a lumber point as this tests even more than the patience of many a dealer. The banks are decidedly conservative in their operations and are not disposed to encourage business based more on speculation than substantial merit. The docks are all pretty well filled up, and yet to do the trade that we anticipate later, and should do, and need to do, greater purchases will be necessary. Prices for coarser grades of lumber have a drooping tendency; for the better grades they remain firm. A good deal of Canadian lumber is being bought by our dealers.

Table listing lumber prices for Buffalo and Tonawanda, N.Y. Includes categories like 'White Pine', 'Box', 'Shingles', and 'Lath' with various grades and prices.

Boston, Mass.

BOSTON, MASS., July 31.—The general situation is without any noticeable features. Business can hardly be called fair—it is possessed of thorough summer quietness. Southern pine in which we are somewhat interested is selling in small lots, nothing more. Trade in cypress lumber is quite active. The output of spruce lumber from the yards is decidedly small, to the extent even of having a depressing effect upon the market. Spruce boards are moving freely. Pine boards are dull and box boards are quiet.

Western Pine—by car load.

Table listing lumber prices for Western Pine by car load, including various grades like 'Uppers', 'Selects', and 'Fine common'.

Eastern Pine—Cargo or Car Load.

Table listing lumber prices for Eastern Pine by cargo or car load, including 'Nos. 1, 2 & 3', 'Ship's bds', and 'West'r pine clapbds'.

Spruce—by Cargo.

Table listing lumber prices for Spruce by cargo, including 'Scantling and plank', 'Yard orders', and 'Clear floor boards'.

Lath.

Table listing prices for Lath, showing 'Spruce by cargo' at 2 10@20.

Shingles.

Table listing prices for Shingles, including 'Spruce', 'Pine, 18 in. extra', and 'Pine, No. 1'.

Oswego, N. Y.

OSWEGO, N. Y., July 31.—No change in prices. Trade is only fair. We are resting on "great expectations" to be cashed later.

White Pine.

Table listing lumber prices for White Pine, including 'Three uppers', 'Pickings', and 'No. 1 cutting up'.

Siding.

Table listing prices for Siding, including '1 in siding, cutting up' and '1 in dressing'.

1x10 Inch.

Table listing prices for 1x10 Inch lumber, including '12 & 16 ft. mill run' and '12 & 16 ft. No. 1 & 2, barn boards'.

1x12 Inch.

Table listing prices for 1x12 Inch lumber, including '12 & 13 ft. mill run, mill culls out' and '12 & 13 ft. dressing and better'.

Table listing lumber prices for various grades and sizes, including '14 to 16 ft. No. 1 culls', '14 to 16 ft. No. 2 culls', and '10 to 13 ft. No. 3 culls'.

ACROSS THE BORDER.

The mammoth lumber interests represented in Omaha, Neb., by the Howell Co., are in financial distress.

Isaac Beringer, the Michigan lumberman is about to begin the erection in Saginaw of an eight-story building for offices to cost \$300,000. This is to serve as one way of "blowing" off some of his surplus cash.

In Western Valentia, in New Mexico, the lumber industry promises to be a very important one within the next two years. Michigan lumbermen have bought up great tracts of timber land in that section and propose erecting saw mills there at an early date. The pine timber in that part of New Mexico is said to be a very superior article.

The market for United States lumber in South America has been very much interfered with by the financial collapse in the Argentine Republic and by the civil war in Chili. Heretofore South America has taken from 300,000,000 to 400,000,000 feet, and now a prominent Savannah lumberman said he did not believe it had taken 2,000,000 within the past six months.

President Oakes of the Northern Pacific refuses to make any reduction in lumber shipments east from Washington over his road although the lumbermen proved to him that cars with a capacity of 103,000 tons went back empty last year. It is estimated that if these only took back 20,000 feet of lumber daily it would have brought \$180 per day of eastern money to the state at only \$9 per 1000 to the mill men.

A single black walnut tree in West Virginia was sold recently to a New York veneer house for \$2,000. Land owners in other Southern States, who have sold similar trees at \$1 apiece in recent years, should now fertilize the stumps and build stone fences around them to keep cattle off the sprouts—which will be valuable some day when they grow up. This the Charlestown News calls "eleventh hour wisdom."

Alger, Smith & Co., of Detroit, will extend the Mud lake branch of the Detroit, Bay City & Alpena road a number of miles, to reach a considerable quantity of timber that has been run over by fire. They have a force of 300 men cutting and peeling the timber. There is about 200,000,000 feet in the track, but only a portion was injured by fire. The same firm has about 30,000,000 feet in the upper peninsula which has been damaged by fire.

Michigan cities, which have heretofore been noted on account of the immense production of lumber are taking great strides in the direction of being manufacturing towns. Improvement associations have been formed, which are working hard to secure manufacturers to locate there. These improvement association are answering the question so often asked by the alarmists. "What will become of the saw mill towns after the lumber is all sawed?"

Col. D. Soper, member of a Chicago lumber firm, was sent out to the Pacific coast about four weeks ago by a prominent brewing company to obtain, if possible, a stick of timber over 100 feet long and four feet square. After spending some little time in prospecting, he finally found a tree in Snoqualmie Valley, in Washington, which filled the bill. The job of cutting down the tree and trimming and loading it on the cars was let to a contractor, who successfully did the work. A half mile of railroad track had to be laid to the spot where the tree stood in order to load it on the cars. The stick from this tree is 111 feet long. It is cut square, each

side being four feet. It was loaded on three 34-foot flat cars, its weight being 90,000 pounds. The cost of getting out this stick of timber has been, so far \$1,300. The cost of moving it to the cars was \$100, and the tarpauln to cover it cost \$100. At Tacoma yesterday the stick was viewed by Sidney Dillon, S. H. H. Clark, Edward Dickinson, and other Union Pacific officials. It will be placed in a big beer hall, in which it is to be used for a counter. It will be polished up in the highest style of the art.

The output of lumber in Washington, Oregon and California for the past year was much larger than that of any previous year. Washington produced 1,820,171,000 feet; Oregon, 829,283,000 feet; California, 864,916,000 feet; total output for the Pacific coast states, 3,522,370,000 feet. The cuts of the leading lumber counties of Washington for the year 1890 were as follows; King, 266,042,000; Jefferson, 229,000,000; Pierce 168,000,000; Chehalis, 122,229,000; Kitsap, 117,518,000; Lewis, 116,500,000; Snohomish, 114,500,000; Spokane, 105,000,000.

The United States census figures show that it cost 1.08 per cent. of the total net value of the product of mills making over five million feet to market their lumber, 2.10 per cent for mills from one to five million capacity and for smaller mills the amount is inconsiderable. The average amount of borrowed capital employed by concerns making more than 5,000,000 feet of lumber annually is found to be \$114,683, and the cost of repairs for mills of this class is found to be 7.38 per cent. of the amount invested in buildings, machinery, etc

The control of the Knapp, Stout & Co. Lumber enterprise, employing seven thousand men, reported to have been purchased by an English syndicate, is to remain in America. It is announced that a new company, to be known as the Knapp-Stout Lumber Company, is being organized. The present management is retained in all departments, with John H. Douglas of St. Louis, in charge of distribution and finances, and T. B. Wilson, at Menominee, Mich., in charge of the manufacturing interest. A portion of the stock of the succeeding company is to be open to subscription. All the bonds and \$300,000 of the stock are taken.

PERSONAL.

Mr. A. H. Campbell, president Muskoka Lumber Co. with his family, are at their summer residence, Muskoka Mills, Ont.

Capt. W. O. McKay, the well-known lumberman of Ottawa, Mrs. McKay and family are at their summer residence below Montreal, Que.

Mrs. Dierks, wife of a successful lumber merchant of Broken Bow, Neb., is holidaying at the home of her parents, Mr. & Mrs. Waters of West Toronto Junction.

James Noble, formerly lumber inspector for Judd & Judd at Tonawanda, N. Y. has taken up his residence in Collingwood, Ont. where he will follow the business of inspecting lumber.

Mr. H. B. Warren of the Imperial Lumber Company, Warren, Ont. is home from a visit to Manitoba. He reports crop prospects good. Mr. Warren owns an extensive farm near Turtle Mountain.

W. D. Cargill, only son of H. Cargill, ex-M. P. and junior member of the firm of H. Cargill, & Son, lumber merchants, of Cargill, Ont., was married last month to Miss Lizzie Kyle, of Chesley.

Secretary Wills of the Toronto Board of Trade has been granted leave of absence for a month to visit England, and Mr. John Donogh of Donogh & Oliver, lumber merchants, will be acting secretary in his absence. A better or more popular appointment could not have been made.

Mr. David Tennant, lumber merchant of this city, died at his late residence 76 Spadina Ave. on 13th ult. Deceased was in his 57th year, and leaves a wife and three children. He was a prominent member of the Ancient Order of United Workmen, of the Select Knights of Canada and also of the Freemasons.

FOR SALE—A RARE CHANCE.

VERY desirable mill property in the town of Essex, Ont., known as the Hanlan Mills, for the manufacture of staves and lumber. The daily capacity of 20,000 feet of lumber and 34,000 staves. Twelve acres of land for mill yard, on which is located 4 charcoal kilns, 1 boarding house, two tenant houses, barns, sheds and other outbuildings, with an unlimited supply of pure well water; with or without horses, trucks, waggons, etc. Also six million feet of standing timber, one-half elm; balance oak, cottonwood, ash, maple and sycamore; from one to three miles from the mill; and other timber in easy reach can be bought. The mills are on the line of Michigan Central Railway, with two spurs running into the mill yard, and within fifteen miles from Detroit. Terms liberal. Good reasons given for selling. Write or call on the proprietor, T. H. DECEW, Essex, Ont.

## NOTABLE ENGLISH OAKS.

THE last number of the "Transactions of the Royal Scottish Aborigicultural Society," gives a description of a number of famous English Oaks, the most notable among which are the "Cowthorpe" Oak, whose age has been variously estimated at from fifteen to eighteen centuries. It stands about three miles from Wetherby, in the West Riding of the County of York. In 1829 Dr. Jessup measured it, and gave its dimensions as follows: Circumference at ground 60 feet, at three feet from ground 45 feet, height 45 feet, extent of principal limb 50 feet, greatest circumference of principal limb 8 feet.

The "Royal Oak" at Boscobel House, in the ancient forest of Brewood, Staffordshire, celebrated in history for having given shelter to Charles II, after the battle of Worcester, on September 6, 1651.

The Earl of Bradford, in a letter dated Weston Park, May 6, 1878, tells the story as follows: "On one occasion when the king was out with one or two of the Penedrils, sounds were heard of horses' feet not very far off. There was not much time for consideration, but his attendants thought he might not be able to get back to his hiding place in the house quietly, or perhaps thought that, even if he did, he might be discovered there, recommended him to go into a thick part of the wood, where they helped him into an Oak tree, and implored him on no account to come down until they returned to him and told him all was safe. They then went as if to their work or ordinary occupation. The troopers of Parliament fell in with them, and made all sorts of enquiries about the house and its inmates, and its neighborhood, and ultimately rode on without discovering how near they were to the king. The Penedrils returned in due time and conducted the king to the house. A pension was bestowed by the English government on this family, which is continued down to the present date, one of the descendants, now a resident of St. John, New Brunswick, being in receipt of it, as the writer is informed. This tree is in a field near the garden of Boscobel House, is surrounded by an iron palisading. It has a circumference at 4 feet up of 12 feet 3 inches.

The "Parliament Oak," in Clipstone Park, Notts, is so called from an informal parliament having been held under it by King John in 1212. Another parliament is said to have been held here in 1290 by Edward I.

This tree stands in a nook by the side of the highway leading from Edwinstowe to Mansfield. It has a circumference at three feet up of 28 feet 6 inches, but is only a living ruin.

William the Conqueror's Oak beyond the fact that this tree has been associated with the Norman's name from time immemorial, its history is unknown. The main stem has long been decayed, and is supported with props. It is situated in Windsor Park, and has a circumference of 37 feet 5 feet up.

In Amptill Park, Bedfordshire, stand the two Amptill Oaks. They are nearly of the same girth, a little over 35 feet at three feet up. On one of the two trees

a short poem of eighteen lines is fastened. The first two of these are as follows:

"Majestic tree, whose wrinkled form has stood  
Age after age the patriarch of the wood."

This provoked the following retort from Lord Wensleydale:

"I'll bet a thousand pounds—and time will show it—  
That this stout tree survives the feeble poet."

"Queen Elizabeth's Oak" stands in Hatfield Park, Hertfordshire. On the morning or afternoon of November 17, 1558, for Mary died between 4 and 5 a.m., Elizabeth was sitting under this tree, when a deputation arrived from the council to apprise her of her sister's demise, and to offer her their homage. She fell on her knees and exclaimed: "*Domino factum est illud, et est mirabile in oculis nostris,*" "It is the Lord's doing, and it is marvelous in our eyes."

Mr. Smith, of Romsey, Hants, the writer of the article referred to, says that he has no measurements of this tree. His paper is full of information, and its reading will amply repay those who wish information on the subject of British Oaks. EDWARD JACK.  
Fredericton, N.B.

## AN OLD PICTURE.

THERE are times when a dream delicious  
Steals into a musing hour,  
Like a face with love capricious  
That peeps from a woodland bower;  
And one dear scene comes changeless;  
A wooded hill and a river;  
A deep, cool bend, where the lilies end,  
And the elm-tree shadows quiver.

And I lie on the brink there, dreaming  
That the life I live is a dream;  
That the real is but the seeming,  
And the true is the sun-flecked stream.  
Beneath me, the perch and the bream sail past  
In the dim, cool depths of the river,  
The struggling fly breaks the mirrored sky,  
And the elm-tree shadows quiver.

There are voices of children away on the hill;  
There are bees thro' the flag-flowers humming;  
The lighter-man call to the lock, and the mill  
On the farther side is drumming.  
And I sink to sleep in my dream of a dream,  
In the grass by the brink of a river,  
Where the voices blend and the lilies end  
And the elm-tree shadows quiver.

Like a gift from the past is the kindly dream,  
For the sorrow and passion and pain  
Are adrift like the leaves on the breast of the stream,  
And the child-life comes again,  
O, the sweet, sweet pain of a joy that died—  
Of a pain that is joy forever!  
O, the life that died in the stormy tide,  
That was once my sun-flecked river.

JOHN BOYLE O'REILLY.

—H. P. Morse & Co., of Vancouver intend soon to put in additional machinery. At present both mill and sash and door factory are running to their full capacity, the former turning out 75,000 feet per day which is expected to increase shortly to 100,000 feet. Not counting those employed in the lumber camps this firm have now 115 men on the pay roll.

## BRITISH COLUMBIA RED CEDAR.

THE annual report of the Vancouver, B. C. Board of Trade furnishes some valuable particulars relative to the trade of that progressive province. The following remarks concerning the red cedar of the province, which comes next in importance to the Douglas fir, will be found of more than usual interest to the lumber trade. "For inside finish the British Columbia cedar is unequalled in color and beauty of grain, and some handsome and striking effects can be produced by the use of this wood. To-day some of the most palatial residences of Canada and the eastern states are finished in British Columbia red cedar, and with excellent effect. It is susceptible of a high polish, which, apart from its rare and beautiful grain, makes it all the more valuable for panel work and ceiling. It is durable beyond belief, and is exceptionally easy to work. In common use it is manufactured into doors, sashes and shingles, and an extensive market has been found in the Northwest Territories and the eastern provinces for these lines, and the demand is constantly growing. Shingles cut from red cedar are absolutely free from knots and they neither curl, warp nor split, and dampness has little perceptible effect on them. For the same reason the wood is particularly adapted to the manufacture of sash and doors. Fort Nesqually built in 1841, was covered with split cedar shingles which are still sound. Roofs laid thirty years ago in Westminster, and for many years covered with moss, have never leaked and appear little the worse for wear. The red cedar has always been in great favor with the Indians, who hollow their canoes out of the wood, because it is so light, splits so true and works easily. The early inhabitants of Queen Charlotte Islands built their houses from red cedar, they being able even with the rude tools then in use among them to split the logs to any thickness required. It is an invaluable timber for the many purposes mentioned, and it is bound to extend until it is found on every market on the continent.

## TRADE NOTES.

A manufacturer writing to an exchange says: "Manufacturers are fast coming to the conclusion that to use any other than a split pulley is one of the things of the past, as changes in machinery, and locations of the same, are so frequent, even in the best regulated factories, that the annoyance and expense of changing a solid rim pulley, by taking down shafting, removing couplings, etc., is so great that most manufacturers prefer to burst them off with a sledge hammer and replace them with properly made split pulleys, or pulleys made in halves. It is, however, so recently that good and well-made split pulleys could be obtained that many have put up with the inconveniences of solid rim pulleys rather than with that "wandering Jew," the cumbersome iron split pulley. But now that a good, light and durable wood split pulley has been introduced, and has been thoroughly tried by many of the representative concerns of the country, and found not wanting in any of the requisites of an ideal split pulley, it would be folly to use any other." In this connection we have pleasure in drawing attention to the advertisement of the Dodge Wood Split Pulley Co. of this city.

Repairing

Promptly and

Carefully

Executed

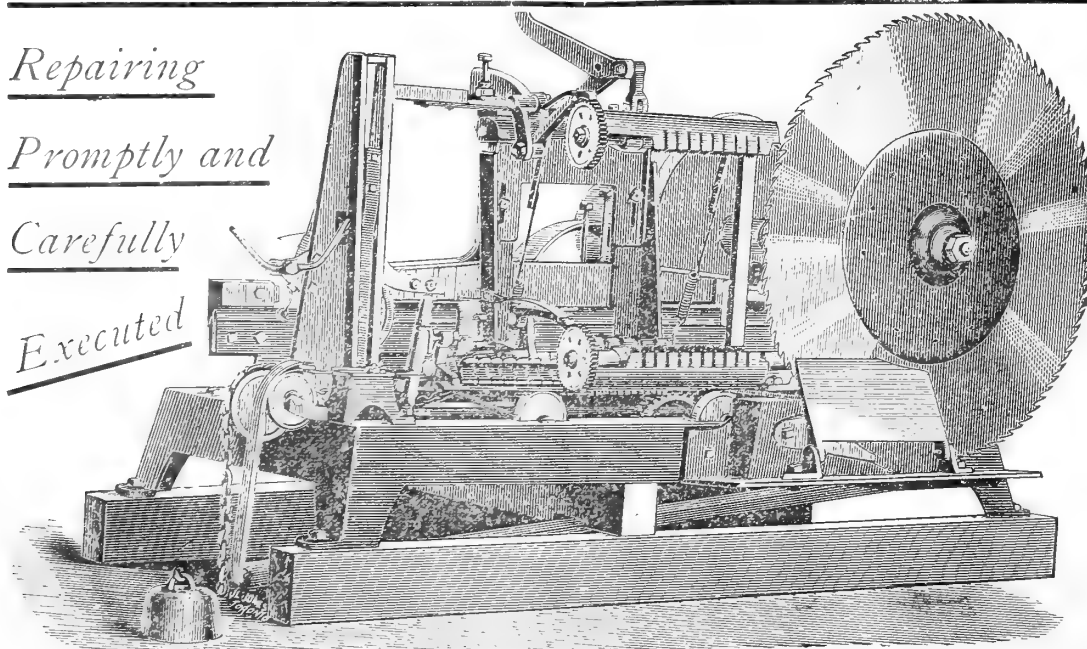

**B. R. MOWRY & SON**

MANUFACTURERS OF

**Saw Mill  
and Shingle Mill  
Machinery.**

Shingle Machinery a Specialty.

**The "BOSS" SHINGLE MACHINE**

Manufactured by us is acknowledged by practical men to be the best machine in the market.

**GRAVENHURST, ONT.**

**WANTED AND FOR SALE.**

Advertisements will be inserted in this department at the rate of 15 cents per line each insertion. When four or more consecutive insertions are ordered a discount of 25 per cent. will be allowed. This notice shows the width of the line, and is set in Nonpareil type. Advertisements must be received not later than the 27th of each month to insure insertion in the following issue.

**For Sale or Will Exchange for Saw Mill Machinery.**

**REAL ESTATE.** valued at \$1,400. The above property consists of lots 1 and 2 Havelock street, in the village of Oxenden, on which there is a large two storey dwelling house and store, with large cellar, good cistern, fresh water pumps and every convenience; besides store house, stables, sheds, and good plum orchard, bearing. Address, W. J. MALLARD, Oxenden, Ontario.

**WANTED—TO BUY.**

**GOOD** Canadian Timber Limits and Georgian Bay saw logs. Address, BEN BIRDSALL, Whitney Building, Detroit, Mich.

**HARDWOOD** lumber, bought, sold or received on consignment, TUCKER DAVID, lumber commission merchant, 202 Eleventh Ave., N.Y.

**RAILS AND CARS FOR SALE.** Light Steel Rails for Tramways; good order. Cars for lumber, cheap.

JOHN J. GARTSHORE, 49 Front St. West, Toronto.

**WANTED.**

**QUEBEC BIRCH**—Those who can furnish choice lumber are invited to correspond with

JOHN S. MASON & CO., 240 Eleventh Avenue, New York City.

**Timber Limits**

BRITISH COLUMBIA.

**FOR SALE!**

\$5,000 to \$50,000 of shares in a Stock Company owning and operating Saw and Planing Mills Sash and Door Factory, etc. Valuable Timber Limits in connection. This is an exceptionally good chance to make money.

Address—LIMITS, Care of CANADA LUMBERMAN, Toronto.

**Muskoka and Georgian Bay Navigation Company.**

**Muskoka Division.**

For all ports upon Lake Muskoka, Rosseau and Joseph, close connections are made daily at Muskoka Wharf with mail and express trains of G.T.R. from Toronto and Hamilton as under.

On Mondays, Wednesdays and Fridays at 7.15 a.m., the Muskoka leaves for Rosseau and intermediate places, and at 1.45 p.m. the "Nipissing" and "Kenozha" leave for all points on the three lakes.

On Tuesdays, Thursdays and Saturdays the "Muskoka" leaves at 7.15 a.m. for Port Cockburn and intermediate places, and at 2.45 p.m. the "Nipissing" and "Kenozha" leave for all points on the three lakes.

**Georgian Bay Division.**

The Str. "Manitou" leaves Parry Sound daily at 7 a.m., calling at Midland on Tuesdays and Fridays and at Penetanguishene on Mondays, Wednesdays, Thursdays and Saturdays. Returning she leaves Midland for Parry Sound on arrival of mail train at 1.42 p.m. on Tuesdays and Fridays, and Penetanguishene for Parry Sound on arrival of mail train at 12.45 p.m. on Mondays, Wednesdays, Thursdays and Saturdays.

The "Manitou" is the only daily boat to Parry Sound and the only boat running the famous South Channel among the islands where the best of fishing is to be had.

**Magnetawan Division.**

The "Wenonah" leaves Burk's Falls daily at 7 a.m. for Magnetawan, Ahmie Harbor and intermediate ports, returning arrives at Burk's Falls at about 5 p.m.

**Good Fishing—Safe Boating and Bathing.**

Full information from any G.T.R. agent. Send for folders with map and full information as to rates &c.

J. S. Playfair, A. P. Cockburn, President, Toronto, Gen. Mgr. Gravenhurst. J. A. Link, Sec. Treas., Gravenhurst.

For information respecting the Georgian Bay Division apply to J. Wilkinson, Purser "Manitou," Penetanguishene P.O.

**E. F. Ames & Co.**

Lumber Commission Correspondence solicited from Canadian manufacturers.

Room 3, Lumber Exchange, Chicago, Ill.

**J. D. SHIER,**

Manufacturer of

**Lumber, Lath and Shingles**

BRACEBRIDGE, ONT.

**WILLIAM FOSTER**  
Lumber & Commission Merchant  
Receiver and forwarder of  
LUMBER, LATH & SHINGLES  
Correspondence Solicited.  
OWEN SOUND, ONT.

**Peter Gerlach & Co.**

Manufacturers of

**ALLIGATOR CHISEL-BIT SAWS**

The Champion Stave, Heading and Shingle Machines.

Ice Tools and Mill Supplies.

CLEVELAND, OHIO.



**ROCHESTER BROS.**  
Commission Agents.

Limits bought and sold on commission. Limits travelled and carefully prepared estimates given. Some first-class berths on the north shore of Lake Huron and on the Upper Ottawa now in our hands for sale. Communications confidential. References given.

36 ROCHESTER ST., OTTAWA.



**A. T. ANDERSON & CO.,**

CONTRACTORS FOR

**ELECTRICAL AND GENERAL MACHINERY.**

Complete instalations of team and Hydraulic Power, Electric Light and Power Plants, Wiring and Construction for Arc and Incandescent Lightings. Agents for the celebrated "C. & C." Electric Motors.

75 Adelaide Street East, Toronto, Ont., Canada.

Estimates furnished and every information cheerfully given to intending purchasers. N. B.—Only first-class work on which a full guarantee will be given.

Cant Dogs, Peavies,  
Skidding Tongs,  
Pike Poles, Coldshuts,  
+ Lumber Bob Sleighs. \*

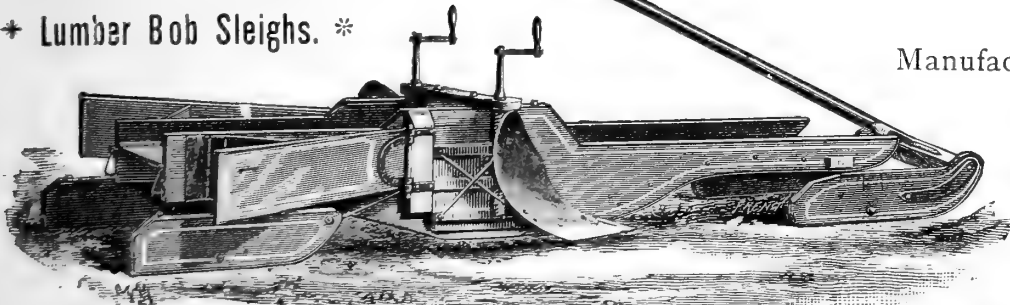

**J. Muckleston & Co.**

Kingston, Ont.

Manufacturers of RED TOP LINE

**LUMBERMEN'S \* TOOLS.**

And Sole Licences for the Manufacture in the Dominion of  
**BRAZEL'S PAT. SNOW AND SIDEWALK PLOWS.**

**Investment Bonds.**

**THE DOMINION SAFE DEPOSIT WAREHOUSING & LOAN CO., LTD.**

Head Office—The Canadian Bank of Commerce Building, King St. W., Toronto.

CAPITAL, ONE MILLION DOLLARS.

**DIRECTORS.**

W. D. Matthews, Esq., President. Henry W. Darling, Esq., Vice-Pres  
John I. Davidson, Esq. S. F. McKinnon, Esq. G. B. Smith, Esq. M.P.P.  
H. W. Nelson, Esq. J. P. Clark, Esq. J. H. Starr, Esq.  
M. C. Cameron, Esq. Robert Kilgour, Esq. Alexander Nairn, Esq.  
Thomas McCracken, Esq. Robert Davies, Esq. Eugene O'Keefe, Esq.  
Aaron Ross, Esq.

This Company is now issuing \$10, \$20, \$30, \$40 and \$500 investments in bonds, payable in five, ten and fifteen years from date of issue, with participation in profits, affording all the advantages of compound interest accumulations on small sums of money. These bonds are the obligations of this Company and are specially protected by a sinking fund, invested in first-class real estate mortgages. They are plain definite contracts, subject to no contingencies whatever, are non-forfeitable after one annual payment, with values definitely stated thereon. For a small outlay they secure a fixed and generous return.

To bondholders who complete their contracts the Company guarantee compound interest at the rate of Four Per Cent. Per Annum.

The Company is prepared to receive applications from reliable agents at all points where it is not already represented.

The Safe Deposit Vaults of the company cannot be surpassed for absolute security. Call and examine or write for circular. **WM. KERR, Manager**

**Our FRICTION GRIP PULLEYS**

ARE THE ONLY SPLIT GRIP PULLEYS & CUT OFF COUPLINGS MADE. GIVE EVERY SATISFACTION AS DRIVERS OR DRIVEN PULLEYS. FULLY GUARANTEED.

**WATEROUS ENGINE WORKS CO**  
BRANTFORD, CANADA



# The Only Successful Kiln for Drying Oak and other Hardwoods

**"THE ANDREWS"**

NEW LUMBER

## DRY-KILN

Its remarkable efficiency depends upon its peculiar mode of applying heat to, and eliminating moisture from, the air used in drying. We use no costly fan, engine or other device that requires constant attention, nor do we waste heat by a special chimney. The air circulates through the lumber, and the moisture absorbed from it is extracted from the air by natural methods. You can not afford to be without it.

Our Process Duplicates Nature.

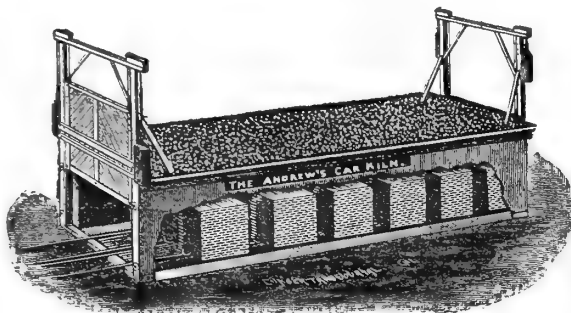

Outside View of the Andrews Kiln.

The following well-known furniture manufacturers have recently purchased the "ANDREWS KILN."

- Estey Manufacturing Co., - - - Owasa, Mich.
- East Shore Furniture Co., - - - Manistee, Mich.
- Universal Tripod Co., - - - Grand Rapids, Mich.
- Grand Rapids School Furniture Co., Grand Rapids, M.
- New England Furniture Co., - Grand Rapids, Mich.
- Milwaukee Chair Co., - - - Milwaukee, Wis.
- Oshkosh Furniture Co., - - - Oshkosh, Wis.
- Skandia Furniture Co., - - - Rockford, Ill.
- Story & Clark Organ Co., - - - Chicago, Ill.
- Rock Falls Manufacturing Co., - - - Sterling, Ill.
- Courey & Birely Table Co., - - - Shelbyville, Ind.
- Southern Spring Bed Co., - - - Atlanta, Ga.
- Sidney School Furniture Co., - - - Sidney, Ohio.
- New Richmond Church Furniture Co., N. Richmond, O.

### A. N. Andrews & Co., Proprietors and Manufacturers

215, 217, 219, 221 Wabash Ave., CHICAGO, ILL.

## The Casselman Lumber Co.

CASSELMAN, ONT. Successors to FLATT & BRADLEY.

ESPECIAL GOOD FACILITIES FOR SHIPPING.

HEMLOCK BILL STUFF OF EXCELLENT QUALITY.

ALSO MANUFACTURERS OF

PINE, SPRUCE, ASH, MAPLE AND OTHER HARDWOODS.

CORRESPONDENCE SOLICITED.

GEO. HASTINGS.

JOHN GRAY.

H. HANCOCK.

## GEO. HASTINGS & CO.

### Lumber Merchants

TRUST BUILDING CHAMBERS,  
Cor. Yonge and Colborne Streets.

TORONTO.

All Kinds of Pine and Hardwood Lumber.

BILL STUFF CUT TO ORDER A SPECIALTY.

J. W. MAITLAND  
H. RIXON

J. G. AINSLIE  
W. STODART

## Maitland, Rixon & Co.,

Owen Sound, Ont.

### Saw Millers and Lumber Dealers

All kinds of Building Material kept in stock.

WE MAKE A SPECIALTY OF

LONG BILL STUFF IN ROCK ELM, PINE, CEDAR AND HEMLOCK

QUOTATIONS FURNISHED ON APPLICATION.

## DONOGH & OLIVER,

Wholesale Dealers in

# LUMBER

OFFICE:

Nos. 213, 214 and 215, Board of Trade Building,

COR. YONGE AND FRONT STS.

TORONTO, ONT.

## THE "LEADER"

The Finest Tempered, Fastest Cutting and Best Saw made on the Continent.



Manufactured of Triple Refined Silver Steel, Rolled specially for us from Superior Ingots.

### THE KING OF CROSS-CUT SAWS.

## R. H. SMITH COMPANY, LTD., ST. CATHARINES, ONT.

Sole Manufacturers.

# Friction Pulley Board.

The Best Materials ever used  
for Frictions of all  
\* kinds \*

MANUFACTURED BY

Asbestos  
Mill  
Board.

The **DOMINION LEATHER BOARD COMPANY,**  
Montreal, Quebec.

Steam  
Packing.

SAMPLES FURNISHED.

PLEASE MENTION THIS PAPER.

CORRESPONDENCE SOLICITED.

The Gold Medal,  
Toronto, 1883

## WOOD WORKING MACHINERY

The Gold Medal,  
London, 1883

For Door, Sash, Blind and Furniture Factories

PLANERS.

MOULDERS.

TENONERS.

SHAPERS.

RIP SAWS.

SAND PAPERERS.

BAND SAWS.

BAND RE-SAWS.

PANEL RAISERS.

DOVETAILERS.

JOINTERS.

DOUBLE SPINDLE BORER.

BUZZ PLANERS.

MORTICERS.

BLIND MACHINERY.

BAND SAW FILER.

BAND SAW SETTER.

ETC., ETC.

# The Galt Bros. Co., Limited,

GALT, ONTARIO.

Write for Circulars  
and Prices.

Correspondence  
Solicited.

Established 1849.

Incorporated 1884.



## Detroit Saw Works

MANUFACTURERS OF

### Circular, Gang, Mulay, Drag and Cross-Cut Saws.

MOLDING AND PLANING KNIVES,

We use nothing but W. J. & Sons' English  
Steel in our saws and the name speaks for itself.

*French Band Saws, Emery Wheels and General Mill Supplies.*

**66, 68, 70 and 72 Fort St. East, DETROIT, MICH.**

## THE STURTEVANT PATENT PROGRESSIVE LUMBER DRY-KILN.

DRIES HARD AND SOFT WOOD LUMBER WITHOUT WARPING, CHECKING OR BLUING.

The Sturtevant  
System of  
**Heating**  
MILLS  
and **FACTORIES**

BOSTON,  
34 OLIVER STREET.

NEW YORK,  
91 LIBERTY STREET.

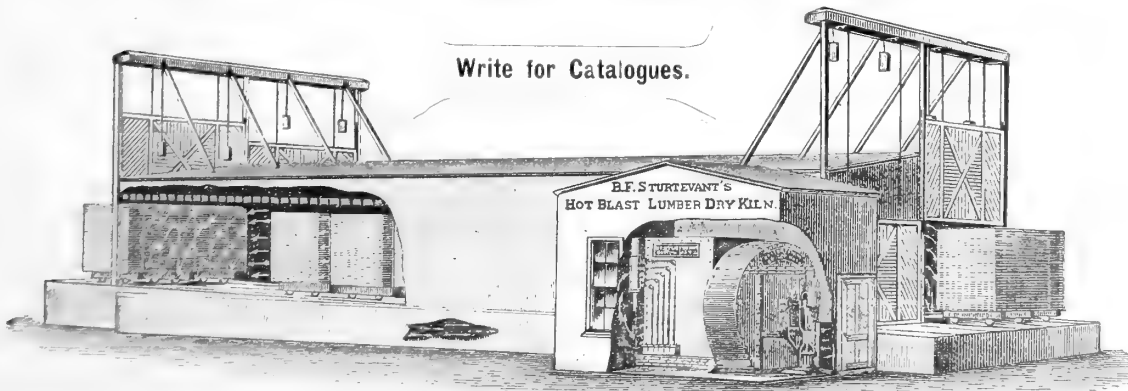

Steel Plate Plan-  
ing Mill  
**Exhausters**  
For Removing  
Chips, Shavings and  
Sawdust.

CHICAGO,  
16 South Canal Street.  
PHILADELPHIA,  
135 North Third Street.

**B. F. STURTEVANT CO., BOSTON, MASS., U.S.A.** | *A. R. WILLIAMS, Soho Machine Works, Toronto*  
GENERAL AGENT FOR THE DOMINION.

# HEAVY SAWMILL MACHINERY

## NO. 4 SAW FRAME With Top Saw Attachment.

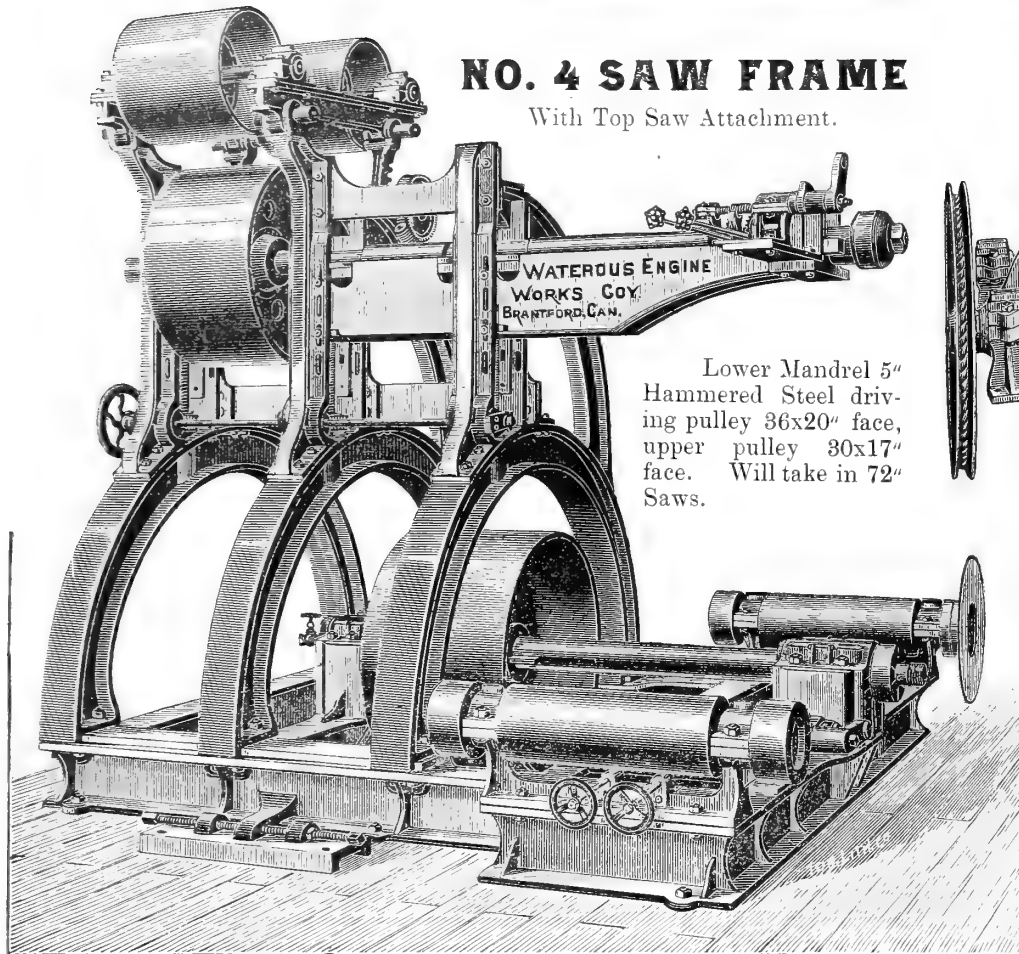

WATEROUS ENGINE  
WORKS COY.  
BRANTFORD, CAN.

Lower Mandrel 5"  
Hammered Steel driving pulley 36x20" face, upper pulley 30x17" face. Will take in 72" Saws.

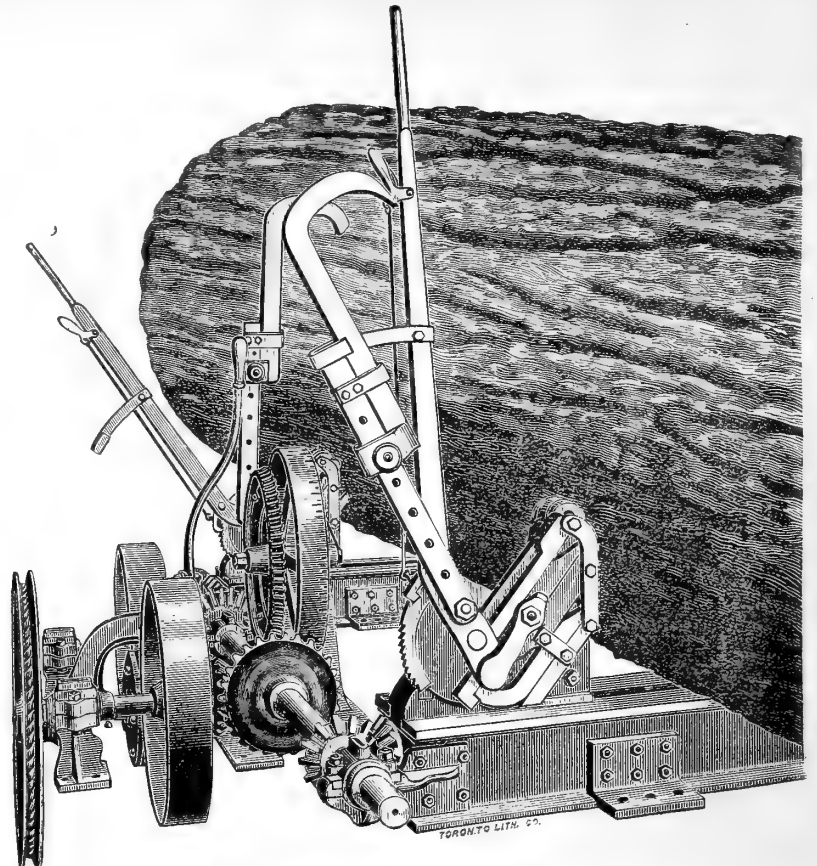

## No. 6 Steel Log Carriage

Made of Wrought and Cast Steel throughout.

SHORT HEAVY KNEES, with roller at top, moved with heavy steel screws.

SET WORKS are our improved power set, actuated by steel cable and entirely under the control of the setter.

LOGSEATS open any distance from saw desired. Carriages made any length.

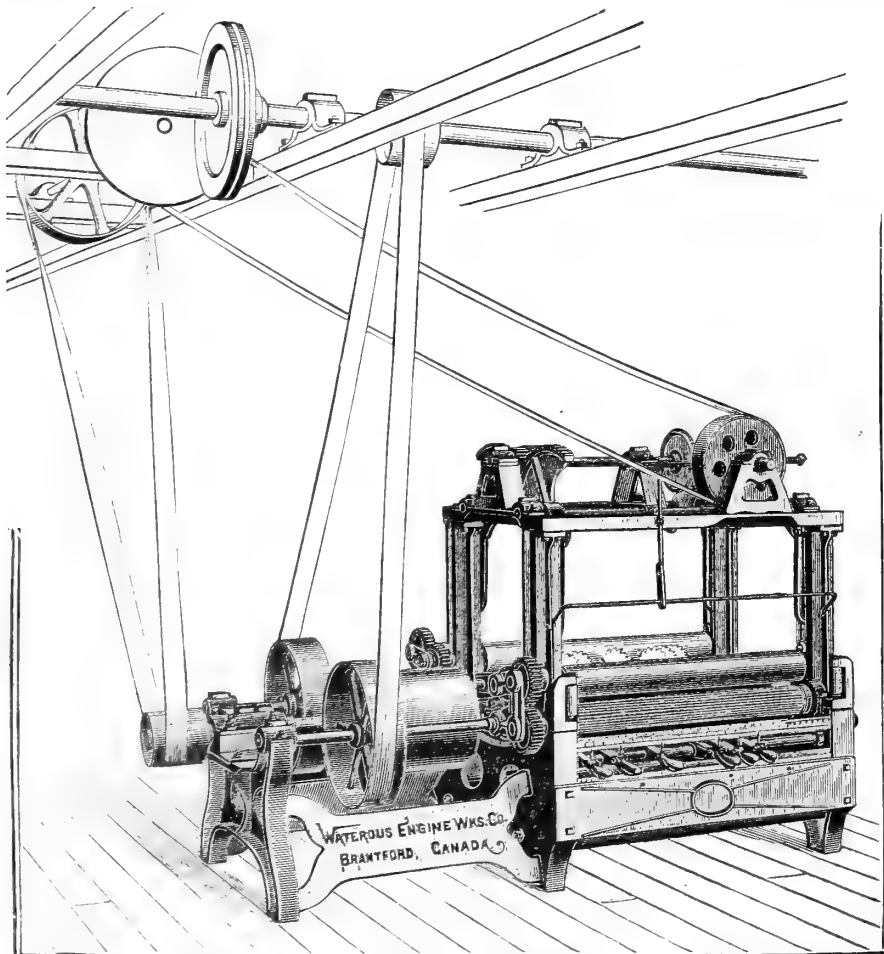

WATEROUS ENGINE WKS. CO.  
BRANTFORD, CANADA

**FEED**; Carriage is driven by our Oscillating Engines, with 14 x 20 cylinders, making an exceedingly strong and uniform feed.

## Champion Gang Edger.

The wide Cants 50 to 60 inches wide, 6 to 9 inches thick, are dropped on rollers and run through the 6 saw Champion Edger, using 6 Hoe bit tooth saws, ripping them into all sizes of dimension timber.

The 4 machines described above, with 6 blocks in the carriage, will weigh in the vicinity of 35 tons.

Send for Circulars and Estimates on full Sawmill Plants.

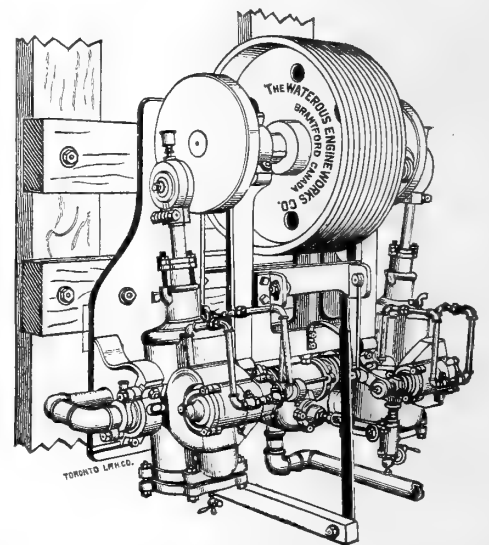

*Waterous Engine Works Co.,  
BRANTFORD, CAN.*



**A. M. DODGE & CO.**  
**M**ANUFACTURERS of and Wholesale dealers in all kinds of Lumber, Lath and Shingles. Tonawanda, N. Y.

**COWPER & GREGORY.**  
**R**ECEIVERS and Forwarders of Lumber, Lath, Shingles, &c. Unexcelled facilities for shipping by canal or rail. Tonawanda, N. Y.

**CHEESMAN DODGE**  
**T**IMBER and Lumber Merchants. Ship and Boat stock, Railroad Ties, &c. Office, 16 West Seneca Street, Buffalo.

**EMMET FLEMING**  
**I**NSPECTOR and Commission dealer in Lumber. Office, 251 Louisiana Street, Buffalo, N. Y.

**LAYCOCK LUMBER CO.**  
**M**ANUFACTURERS of Pine, Hemlock and Oak Timber up to 5 1/2 feet in length. Saw Mills: Ackley, Pa., Black Rock, N. Y., Gravenhurst, Ont. Office, corner Main and Seneca Sts., Buffalo, N. Y.

**J. & T. CHARLTON**  
**W**HOLESALE dealers in Masts and Spars, Canada Round Pine, &c. Tonawanda, N. Y.

**WILLARD W. BROWN.**  
**202** Main Street, Buffalo, handles all kinds of Hard Woods.

**A. P. & W. E. KELLEY CO.**  
**W**HOLESALE Lumber dealers. Yards at Tonawanda and Chicago. Correspondence invited.

**C. P. HAZARD.**  
**W**HOLESALE dealer in Lumber, Shingles, Lath and Fence Posts. Correspondence invited from the Canadian trade. No 92 River Street, Buffalo, N. Y.

**L. A. KELSEY LUMBER CO., (Ltd.)**  
**M**ANUFACTURERS and dealers in Hardwood Lumber of all kinds. Describe stock and write for prices. Office Tonawanda, N. Y.

**BOVEE & HOWDEN**  
**M**ANUFACTURERS and Wholesale dealers in Hard and Soft Wood Lumber. Holders of Canadian stocks are invited to write for quotations. Offices at Tonawanda and Le Roy, N. Y.

**THE TONAWANDA LUMBER CO.**  
**M**ILLS at East Tawas, Mich.; office 106 Main Street, opposite N. Y. C. and H. R. R. R. Station, North Tonawanda, N. Y.

## Cash for Lumber

W. N. McEachren & Co.

Wholesale dealers in all kinds of

## HARDWOOD LUMBER

NO. 3 DOCK  
 TORONTO

WRITE US FOR PRICES AND SIZES TO CUT.

WE PAY CASH WHEN LOADED ON CARS.

HERBERT G. ROSS. Box 273. REGINALD C. BLAKER.

## H. G. ROSS & CO.

Real Estate, Fire and Life Insurance, Shipping and General Commission Agents.

Timber Limits and Farming Lands a Specialty.

A.B.C. Code, Cable address, "Ross."

NEW WESTMINSTER. - - - B. C.

CORRESPONDENCE SOLICITED.

## LUMBER

### TRUCK \* WHEELS.

\*\*\*\*\*

## The Montreal \*

## \* Car Wheel Co.

MANUFACTURERS OF

### CHARCOAL IRON CHILLED

## RAILROAD WHEELS

Offices: New York Life Insurance Building, Montreal.

Works: Lachine, Quebec.

\*\*\*\* \*

WE make a Specialty of Wheels suitable for the requirements of Lumbermen and Street Car Service, and can supply them Bored, Finished and Balanced.

CORRESPONDENCE SOLICITED

### J. J. TURNER, Sail, Tent and Awning Maker.

251 GEORGE AND 154 KING STREETS,  
 PETERBOROUGH.  
 Canoe, Yacht and Boat Sails made to order. Perfect Fits guaranteed.  
 Every description of Lumbermen's Subblies and Waterproof Clothing.

### THE MONARCH BOILER (PATENTED) AND HERCULES ENGINE.

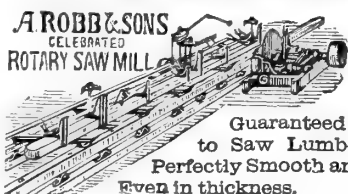

Guaranteed to Saw Lumber Perfectly Smooth and Even in thickness.  
 Portable from 6 to 70 horse power. Surpass portable steam power heretofore produced for strength, durability, compactness, and the ease with which they can be moved.  
 The 70 horse power can be taken over the roughest roads, or into the forest, and set up as easily and quickly as an ordinary 20 horse power portable engine, and as firm as a brick-set stationary engine. Engines and boilers of every size and description. Rotary Saw Mills, Shingle and Lath machines, Law Grinders, Planers, etc. Mill machinery and supplies of every description. Every boiler insured against explosion by the Boiler Insurance & Inspection Co. of Canada. Write for circulars.  
 A. ROBB & SONS, Amherst Foundry and Amherst, N.S. Machine works.  
 ESTABLISHED OVER 40 YEARS.

DALTON McCARTHY,  
 President.

JOHN MCGREGOR,  
 Manager

## Toronto and Midland Mfg Co.

INCORPORATED.

## Wholesale \* Lumber \* Dealers

AND MANUFACTURERS OF

### DRESSED LUMBER, FLOORING

Ceiling, Sheeting, Siding, Shelving, Mouldings of all Description.

Office and Yard:

FOOT OF SPADINA AVE., - TORONTO.

Planing Mills: MIDLAND, ONT.

## PORTER, ROBERTSON & CO.

STOCKS  
 STRIPS  
 SIDINGS  
 BILLSTUFF

WHOLESALE

## LUMBER

DEALERS

HARDWOODS  
 HEMLOCK  
 SHINGLES  
 LATH, ETC.

Millichamp's Buildings,

35 \* Adelaide \* Street \* East,  
 TORONTO.

YARD: NORTHERN DOCK, FOOT OF BATHURST STREET.

### NAPANEE CEMENT WORKS

— MANUFACTURERS OF —

## Hydraulic Cement

PARTICULARLY adapted for Dams, Smoke Stacks, Foundations, Culverts, Cisterns, Cellars, etc.

ENDORSED BY LEADING RAILWAYS AND CONTRACTORS.

### ROACH \* LIME,

For Building, Plastering, Gas Purifying, Paper Making, &c.

## THE RATHBUN COMP'Y, DESERONTO, ONT.,

MANUFACTURERS OF

## \* TERRA \* COTTA \* FIRE-PROOFING \*

For Use in Old and New Buildings.

Endorsed by Leading Architects. Absolutely Fire-proof. About as Cheap as Wood or Brick. Weight One-Third that of Brick. Does not Crack on application of Heat or Water. Deadens Noise. Gives Warmth in Winter; Coolness in Summer.

## Galt \* Machine \* Knife \* Works.



### MACHINE KNIVES

OF EVERY DESCRIPTION FOR

Planing, Moulding & Stave Cutting.

SEND FOR PRICE LIST

PETER HAY, - - - GALT, ONT.

# Do you want a MACHINE ? ENGINE ? BOILER ?



If so

# Cheap ?

READ THIS LIST AND WRITE FOR PARTICULARS AND PRICES TO

H. W. PETRIE, 141-145 FRONT ST. W., TORONTO. TELEPHONE 2590.

## Wood-Working Machinery.

ONE new eclipse planer and matcher, Galt make.  
**C**HAMPION planer, matcher and moulder, McGregor, Gourley & Co. builders; nearly new.  
**N**O. 6 planer and matcher, Cowan & Co's build.  
**L**ITTLE giant planer, matcher and moulder Price, \$200.  
**N**EW poney planers and matchers, only \$175.  
**F**OUR 20-inch poney planers; Harper, Cant Bros., Waterous, and Ross make.  
**24**-inch poney planer, Frank & Co's make.  
**N**O. 4 poney planer, McKechnie & Bertram's build.  
**24**-inch poney planer, Ross' make, Buffalo.  
**24**-inch wood frame planer, Kennedy & Son's make.  
**24**-inch wood-frame surface planer. Cheap.  
**24**-inch surface planer, Rogers' make, Norwich, Conn.  
**21**-inch wood-frame planer, Kennedy & Sons' build.  
**22**-inch surface planer—McKechnie & Bertram.  
**12**-inch diagonal buzz planer, new; Galt make.  
**D**ANIEL'S planer, R. Ball & Co's make.  
**B**EADING and moulding attachment for planer, Kuss make, Buffalo.  
**N**O. 4 four-side moulder, McGregor, Gourley, builders.  
**8**-inch four-side moulder, Dundas build.  
**N**O. 1 1/2 three-side moulder, McGregor, Gourley builders.  
**N**O. 2 three-sided moulding machine, Galt make.  
**T**HREE-SIDE moulder, Rogers' make, Connecticut.  
**O**NE-SIDE moulder, Dundas build.  
**N**O. 0 shaper, McGregor, Gourley, builders.  
**S**HAPERS No. 1 and 2, Galt make.  
**N**EW power morticer, Galt make, also several second hand.  
**8** BORING machines—by different makers.  
**R**ESAWING machines—I have two band resaws, one circular resaw, all Galt make.  
**T**ENONING machine—one each, Goldie & McCulloch, McKechnie & Bertram, Ross & Cant Bros. make.  
**T**WO from handle lathes, with cutters and countershafts.  
**O**NE axle handle and spoke lathe.  
**W**OOD turning lathes, several sizes, new and second hand.  
**I**MPROVED power rod feed machine, McGregor, Galt, builders.  
**S**AND papers and knife grinders, several of them.  
**I**MPROVED saw arbors, all sizes, Galt make, in stock.  
**O**NE 18-pronged iron frame swing saw, new, Buffalo.  
**N**O. 10 saw, also 36-inch, band saws, Galt make.  
**N**EW 25-inch band saw, Cant Bros. make, Galt.  
**H**Y SCROLL and jig saws, at various prices.  
**N**O. 1 universal saw bench, H. B. Smith, builder.  
**C**OMBINATION saw bench, Haggis, builder, in stock.  
**10** WOOD frame saw benches at very low prices.  
**T**HREE blind-cut tenoners, all Galt make.  
**D**IRTYGE wood-split pulleys at manufacturer's price. Quick delivery.  
**F**LAT and hand watering machines, latest design.  
**F**OOT and hand wiring machine, Galt make.  
**O**NE set cheese box machines.

## Miscellaneous Machinery.

**T**WO sets match machines. Also set clothes' pin machinery.  
**2** DRY KILN outfits, also several fans by different makers.  
**F**ULL particulars of any machine in above list on application.  
**T**WO sets cracker or biscuit machines with fine assortment of dies.  
**R**UGER & CO., builders.  
**O**NE leather rolling machine.  
**O**NE corn husker, Sell's make.  
**S**EVERAL buhr stone chopping mills.  
**O**NE ditching machine.  
**O**NE clover huller and thresher.  
**O**NE bobbin winder, Georgetown make.  
**O**NE laundry hand shirt ironer.  
**O**NE power and two hand paint mills.  
**S**EVERAL wrought and cast iron tanks and kettles.  
**B**ONE mill for green bones. Capacity 1/2 lb. per minute.  
**O**NE lot canning factory tools, presses, solder moulds, etc., etc.  
**O**NE galvanic battery, (McIntosh) Chicago, Ill. make.  
**H**AND and power meat choppers, also sausage stuffers.  
**100** PRESS plates for cotton or woollen mill use.  
**O**NE soda water fountain.  
**4** GREEN corn cutting machines.  
**2** SETS fulling mill crank shafts with bearings and wheels.  
**P**ORTABLE forges; genuine Buffalo make.  
**O**NE Eureka smut machine and one purifier.  
**N**O. 2 Caligraph writing machine, also a World typewriter.  
**O**NE Ronald steam fire engine.  
**T**WO village hand fire engines.  
**O**NE Silsby steam fire engine.  
**T**WO Diamond mill stone dressers.  
**S**EVERAL large iron band wheels, turned and balanced.  
**O**NE 62 gallon Gasoline tank, Buffalo make.  
**O**NE sugar cane mill, Cincinnati build.  
**O**NE stump machine screw, also three cloth press screws complete.  
**N**EW hand corn shellers, only \$4 each.  
**C**ENTRIFUGAL pumps, all sizes.  
**C**OMplete steam heating plant for public or private building; a bargain.  
**O**NE clay crusher, Galt make.  
**O**NE shooting gallery tube.  
**B**OILER tube expanders and brushes; all sizes.  
**O**NE new 60-foot steam pleasure yacht at a bargain.  
**H**Ydraulic rams, several sizes, Seneca Falls build.  
**T**WO set plate bending rolls for boiler shop use.  
**O**NE derrick hay press, good order.  
**O**NE lot new bolting cloths, Goldie & McCulloch make.  
**O**NE lot woollen machinery, cards, pickers, etc.  
**B**BRICK and tile machines, one of each.  
**T**WO fire proof safes, both good as new.

## Engines.

**225** HORSE power pair of engines, Northy & Co., builders.  
**75** HORSE power horizontal engines, Gartschore build.  
**50** HORSE power horizontal engine, Goldie & McCulloch builders.  
**45** HORSE power horizontal engine, White-law, builder.  
**35** HORSE power horizontal engine, Northy make.  
**30** HORSE power horizontal engine, Northy & Co., builders.  
**25** HORSE power horizontal engine, American make.  
**25** HORSE power horizontal engine, Waterous Engine Company build.  
**25** HORSE power horizontal engine, McRae build.  
**20** HORSE power pair of twin engines, Montreal build.  
**20** HORSE power horizontal engines, F. G. Beckett & Co., build.  
**20** HORSE power rotary steam engine, Erie Iron Works make.  
**20** HORSE power horizontal engine, Ki ley, builder.  
**18** HORSE power horizontal engine, George White builder.  
**16** HORSE power horizontal engine, American make.  
**16** HORSE power horizontal engine, Beckett make.  
**16** HORSE power horizontal engine, Tift & Sons, builders.  
**15** HORSE power horizontal engine, F. G. Beckett, builder.  
**15** HORSE power horizontal engine, Mount Forest make.  
**12** HORSE power horizontal engine in good order.  
**12** HORSE power horizontal engine, American make.  
**12** HORSE power horizontal engine, Kelley, maker, Hamilton.  
**10** HORSE power horizontal engine, F. G. Beckett builder.  
**10** HORSE power vertical engine, Swamscott Machine Co., make.  
**8** HORSE power vertical engine in good order.  
**6** TO 8 horse power twin engines, marine; American build.  
**6** TO 8 horse power new double cylinder engine; marine.  
**6** HORSE power automatical vertical engine; Berlin make.  
**6** HORSE power new champion engine, Waterous make.  
**6** HORSE power oscillating engine, Beckett build.  
**5** HORSE power upright engine, Cine make, Alliance, Ohio.  
**6** HORSE power horizontal engine, Reid & Barr, builders.  
**4** HORSE power horizontal engine; good order.  
**3** HORSE power horizontal boat engine, Meakins make.  
**3** HORSE power vertical marine engine, good as new.  
**3** HORSE power vertical yacht engine; new.  
**2 1/2** HORSE power rotary engine; new.  
**2** HORSE power horizontal engine; refitted.  
**1 1/2** HORSE power yacht engine, vertical; American build.  
**1** HORSE power horizontal engines; three in stock.  
**1-4** HORSE power horizontal engine, Yankee make.  
**T**WO rotary engines, Josiah Ross patent and make; send for cut.  
**I**RON and brass castings for model steam engines.  
**E**NGINE governors, all sizes and by different makers.  
**F**ULL particulars regarding any of above engines on application. I also have a large stock of portable and semi-portable engines and boilers.

## Boilers

**B**OILER 16 feet x 48 inch, 50 tubes 3 inch.  
**B**OILER 15 1/2 feet x 52 inch, 76 tubes 2 1/2 inch.  
**T**WO boilers 15 ft. x 60 in., 84 tubes 3 inch.  
**B**OILER 14 ft. x 54 in., 62 tubes 3 inch.  
**B**OILER 14 ft. x 48 in., 52 tubes 3 inch.  
**B**OILER 14 ft. x 36 in., 28 tubes 3 inch.  
**B**OILER 13 1/2 ft. by 36 in., 33 tubes 3 inch.  
**B**OILER 12 ft. 9 in. x 36 in., 33 tubes 3 inch.  
**B**OILER 11 1/2 ft. x 3 ft. 32 tubes 3 inch.  
**B**OILER 11 1/2 ft. x 3 ft., 30 tubes 3 inch.  
**B**OILER 11 ft. 6 in. x 30 in., 33 tubes 2 1/2 inch.  
**B**OILER 11 ft. x 48 in., 55 tubes 3 inch.  
**B**OILER 11 ft. x 40 in., 34 tubes 3 inch.  
**B**OILER 10 1/2 ft. x 40 in., 33 tubes 3 inch.  
**P**AIR of boilers each 10 ft. 4 in. x 26 in., 11 tubes 3 inch in each.  
**B**OILER 10 ft. x 44 in., 50 tubes 3 inch.  
**B**OILER 8 ft. 10 in. x 30 in., 31 tubes 2 inch.  
**B**OILER 8 ft. 3 in. x 25 in., 16 tubes 3 inch.  
**B**OILER 8 ft. x 35 in., 28 tubes 3 inch.  
**B**OILER 7 ft. x 25 in., 18 tubes 2 1/2 inch.  
**B**OILER 6 ft. x 30 in., 20 tubes 3 inch.  
**B**OILER 6 ft. x 22 in., 9 tubes 3 inch.  
**B**OILER 57 in. x 30 in., 17 tubes 2 1/2 inch.  
**U**PRIGHT boiler 7 ft. 4 in. x 36 in., 84 tubes.  
**U**PRIGHT boiler 65 in. x 24 in., 21 tubes 3 inch.  
**U**PRIGHT boiler 4 ft. 10 in. x 30 in. 40 tubes, 2 1/2 inch.  
**U**PRIGHT boiler 42 in. x 30 in. 37 tubes 2 inch.  
**U**PRIGHT boiler 33 in. x 12 in., 4 tubes 2 inch.  
**U**PRIGHT boiler 30 in. x 13 in., 19 tubes 1 1/2 inch.  
**P**ORTABLE fire box boiler 16 1/2 ft. x 54 in., 55 tubes 3 1/2 and 4 inch.  
**P**ORTABLE fire box boiler 12 ft. x 3 ft., 29 tubes 3 inch.  
**P**ORTABLE fire box boiler 11 ft. x 45 in., 28 tubes 2 1/2 inch.  
**P**ORTABLE fire box boiler 10 1/2 ft. x 25 in., 13 tubes 3 inch.  
**P**ORTABLE fire box boiler 10 ft. x 3 ft., 35 tubes 2 inch.  
**P**ORTABLE fire box boiler 8 1/2 ft. x 30 in., 36 tubes 2 inch.  
**F**OR full particulars and prices of the above boilers, apply to H. W. Petrie, 141 and 145 Front Street West.

Remember The Address.

**H. W. Petrie**  
**TORONTO, ONT.**

Two Minutes Walk From  
 Union Station.

C. C. CLEVELAND. G. F. CLEVELAND.  
**J. L. GOODHUE & CO.,**  
 MANUFACTURERS OF  
**Leather Belting**  
 AND  
**Lace Leather.**  
 DANVILLE - - QUEBEC.

THIS SPACE FOR SALE.

RAILROAD, BANK & OFFICE  
**DESKS**  
 TEES & CO.,  
 300 ST. JAMES STREET, MONTREAL.

**STORAGE OF LUMBER.**  
 We are prepared to receive any quantity of Lumber for storage. Freight and money will be advanced on same. Also, Warehouse Receipts issued, which can be hypothecated to banks and others. Storage charges easy. For further particulars apply to  
**W. LEAK & CO.**  
 Lumber, Coal and Wood.  
 DUNDAS STREET, - - TORONTO.

**GOODDAY, BENSON & CO.**  
 QUEBEC, P. Q.  
**General Lumber & Timber Merchants.**  
 Correspondence is solicited from parties having choice stocks of Hardwood and Pine to offer, either in the log or in sawn lumber.

**JOHN BERTRAM & SONS,**  
 CANADA TOOL WORKS  
 DUNDAS, ONTARIO.  
 MANUFACTURERS OF  
**WOOD-WORKING MACHINERY**  
 MACHINE TOOLS, ETC.  
 Write for Prices and Catalogues

THIS SPACE FOR SALE.

**GEO. CORMACK**  
 Wholesale and Retail Dealer in  
*All kinds of LUMBER.*  
 Lumber Shipped to all parts by Rail or Vessel.  
 WHITBY, - - ONTARIO

**Toronto**  
**Lithographing Co.**  
 LITHOGRAPHERS &  
 TORONTO. ENGRAVERS.

THOS. WHALEY, President. W. E. HUTCHINSON, Sec.-Treas.  
**The Whaley Lumber Co.**  
 OF HUNTSVILLE, ONT. (LIMITED)  
 Manufacturers of  
**White Pine Lumber, Bill Stuff, Lath and Shingles**  
**ALSO HARDWOOD LUMBER.**  
 All orders promptly attended to. First-class facilities for shipping.  
 CORRESPONDENCE SOLICITED.

**THE RATHBUN COMPANY,**  
 DESERONTO, - - ONTARIO,  
 MANUFACTURERS OF  
**Doors, Sash, Blinds, Stairs**  
 AND ALL KINDS OF WOODEN HOUSE FINISHING MATERIALS.  
**CEDAR OIL FOR PURGING BOILERS.**  
 CORRESPONDENCE SOLICITED

**The American Lumber Yard**  
**HAMBURG, GERMANY,**  
 Offers the best facilities for Yarding and Selling all kinds of  
**American Wood Goods.**  
 Address: ROSENBACHER & CO., Bankers, Hamburg. CARL GARTNER, Agent, Hamburg.

**ROBIN & SADLER**  
 MANUFACTURERS OF  
**Leather Belting**

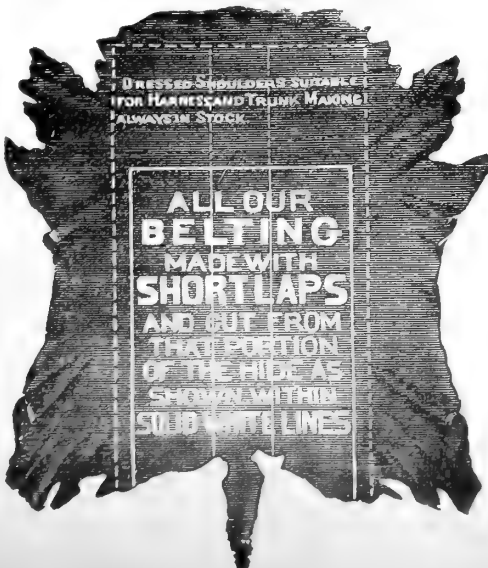

DEALERS IN  
**Lace Leather**  
 Cotton and  
**Gandy Belting**  
 2518, 2520 and 2522 Notre Dame St. MONTREAL.  
 129 Bay Street, TORONTO.



TAPER TOOTH.

Large and Small

LANCE TOOTH.



CIRCULAR AND  
CROSS-CUT  
**Saws**

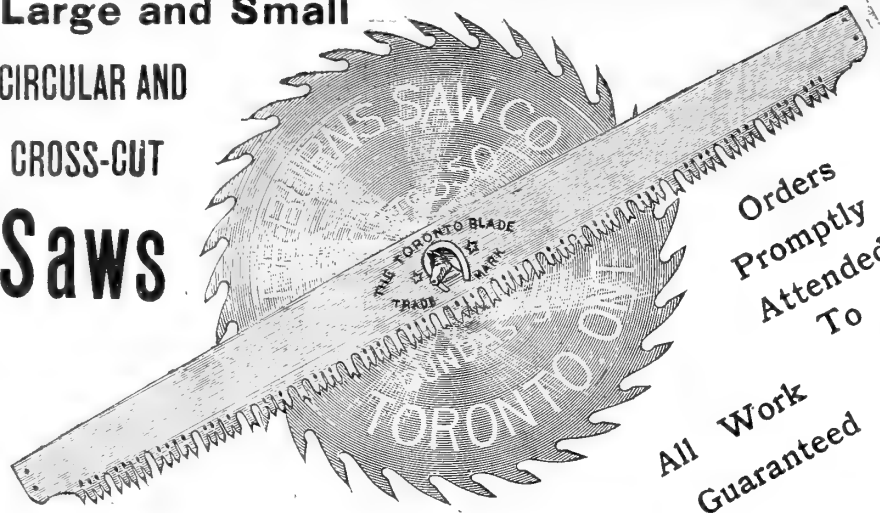

Orders  
Promptly  
Attended  
To  
All Work  
Guaranteed

TELEPHONE 5120.



WORKS AT PARKDALE.

TORONTO AGENCY OF

**The Rathbun Co.**

ARE OPEN TO PURCHASE  
OAK, ASH, BIRCH,  
BASSWOOD  
AND  
GOOD PINE LUMBER  
CEDAR AND PINE  
SHINGLES

Manufacturers having such for sale are invited  
to communicate with

**T. W. WALKER, Agent**  
**TORONTO**

Office, Cor. Spadina Ave. & Front St.



SCRIBNER'S  
**LUMBER**  
AND  
**LOG BOOK**

Over One Million Sold.

**M**OST complete book of its kind ever published. Gives measurement of all kinds of Lumber, Logs, Planks, Scantling; cubical contents of square and round Timber; hints to lumber dealers; wood measure; speed of circular saws; care of saws; cord-wood tables; felling trees; growth of trees; land measure; wages, rent, board, interest, stave and heading bolts, etc. Standard book throughout the United States and Canada. Get the new illustrated edition of 1882. Ask your book-seller for it. Send post-paid for 35 cents.

**GEO. W. FISHER,**  
Box 238, Rochester, N. Y.

or A. G. MORTIMER,  
Toronto, Ontario.

**WICKES BROS.,** Saginaw, Mich.

MANUFACTURERS OF

**GANGS,  
ENGINES  
AND  
BOILERS.**

The accompanying cut represents our new No. 3 Complete Iron Frame Gang Mill especially designed to meet the demand for a smaller type of mill. The strongest and most durable for high speed and thin saws. Write for further particulars.

Southern Agents,  
**McARDLE & SINCLAIR,**  
50 & 52 Barronne St  
New Orleans, La.

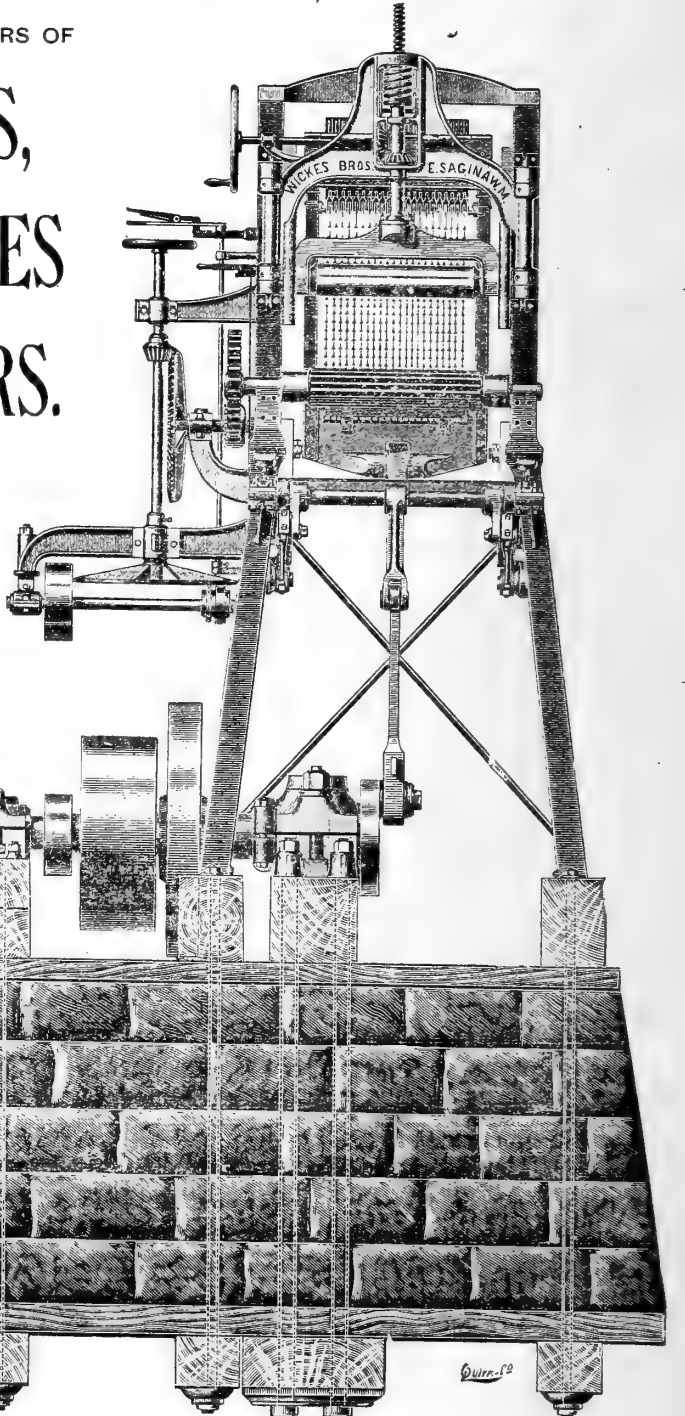

**IMPORTANT TO LUMBERMEN AND ALL WHO USE** **Leather Belting.**

You all use more or less Leather Belting, and are naturally interested in knowing where to get the very best article. That which will give you the least trouble either in stretching crooked or tearing at the lace holes.

**F. E. DIXON & CO'S UNION TANNED**

Belting runs straight and easy on the pulleys, is thoroughly well stretched and cannot be surpassed for strength and durability. Send for discounts. Our hand books of leather belting mailed free on application.

Round Plaited Belts from  $\frac{3}{4}$  inch to  $\frac{1}{2}$  inch. Lace Leather.  
PATENT WIRE LACING, &c.

**F. E. DIXON & COMPANY**  
70 KING STREET EAST., TORONTO.

PATENTED 5TH MARCH, 1877.

**PARKER & EVANS,**

Sole Proprietors of the

FAMOUS INTERNATIONAL

**BOILER - FLUID - COMPOUND.**

This compound will save its cost many times in one year by saving fuel.

It eradicates scale, and when the Boiler is once Clean a very small quantity keeps it clean and free from all incrustation. One fourth the dose will prevent a new Boiler from scaling so long as it is used regularly.

Contains no Caustic Soda, and is the only matter yet known that will not injure metals in any way, and emits a clear pure steam.

**30 WILLIAM STREET, - MONTREAL.**

**Fawcett & Co.**

**MERCHANT \* TAILORS,**  
269 Queen St. E., Opp. Seaton St., Toronto.

First-Class Goods and Trimmings. Workmanship and Fit Guaranteed.  
All Orders Punctually Executed.

# THE CANADA LUMBERMAN.

VOLUME XII. }  
NUMBER 9

TORONTO, ONT., SEPTEMBER, 1891.

TERMS: \$1.00 PER YEAR  
SINGLE COPIES FIVE CENTS

## WHEN WE PLANT THE TREE.

**W**HAT do we plant when we plant the tree?  
We plant the ships which cross the sea ;  
We plant the mast to carry the sails ;  
We plant the planks to withstand the gales—  
The keel, the keelson and beam and knee ;  
We plant the ship when we plant the tree.  
What do we plant when we plant the tree ?  
We plant the houses for you and me,  
We plant the rafters, the shingles, the floors,  
We plant the studding, the lath, the doors,  
The beams, the siding, all parts that be ;  
We plant the house when we plant the tree.  
What do we do when we plant the tree ?  
A thousand things that we daily see ;  
We plant the spire that out-towers the crag,  
We plant the staff for our country's flag,  
We plant the shade, from the hot sun free ;  
We plant all these when we plant the tree.

## SAW MILL BUILDING.

BY J. H. MINER.

**A**RRANGING a mill to cut 10,000 feet in ten hours, with seven hands, including piling of lumber and arranging bill stuff, may sound a "little off" to those who are employing twice that number of men.

First, it is best to set the mill with end to a hillside and receive the logs on a car. This is best where bills are cut on short notice, as logs can be received from both sides of the track.

If logs are to be sawed as they come, they may be received more conveniently from the side. In this case it is much better to build an overhung roof, so that all in front of the carriage will be clear. The logs should be dropped as closely to the mill as possible, to save much rolling.

The carriage I have partly described. What is wanted is a cheap, quick and reliable overhead turner. The cost of machinery, of course, must be carefully compared with labor. Fifty dollars will put up a log turner which fifty days running will pay for in the saving of the man, to say nothing of the increase in cut. A great drawback in small mills is not having a log-turner ; to get the same results requires two, sometimes three extra men.

To construct the log-turner, put a 36x8 inch friction pulley on a three inch shaft four feet long. This shaft is set, say three to six inches over the end of the head-blocks. Next a two-inch shaft with 8x8 paper or wood friction pulley on the outer end, working in a sliding box. This shaft extends back over the saw mandrel, where power is taken. The feed shaft should be reduced about one-third. Use not smaller than twenty-inch pulley on saw mandrel, or larger if the logs are heavy. If the feed rig interferes with putting the pulleys in right, increase the size or diminish the pulleys. The belt being a quarter-twist, will necessitate the driven pulley being larger to get farther from the saw. Few sawmills are constructed so that a turner of this kind cannot be used.

The question of the chain comes next, but not in a tricky intermediate friction. On the end of the three-inch chain shaft a wood spool, say eight to twelve inches diameter, is placed ; around this is wound a rope with a heavy weight attached to hang out of the way. The lever that handles the friction is arranged with a brake working on the face of the large iron pulley. The sawyer pulls his lever gently, unwinding the chain as desired which is done while sawing. The chain remains just where left. This constitutes the best and most reliable rig out. It cannot get out of order and is quick.

The sawyer, setter and one man to roll down logs constitutes the saw crew. The log deck man handles the chain while setter attends to releasing the dogs.

While log is being sawed up he is rolling down or bringing in logs on a car. The sawyer stands behind the saw to down the boards (which is the proper place for him.)

The first five or six rollers are made live by simply attaching a sprocket wheel on the end of roller shaft, which should not be less than one inch, and must extend through the roller, which must not be less than ten or eight inches in diameter, as the sprocket wheel must be two inches smaller, to allow an inch board to protect the operators. The first roll is driven with a three-inch belt from the saw mandrel. The link belting or chain drives the rolls by simply passing over the top of the sprockets, except the first and last. Rollers may be made of dry hardwood with a key pin through the center, or they will soon become loose and worthless. A rig of this kind will cost but \$30 above the ordinary rig, and give thirty to forty feet of live rolls, as desired.

The space between car track and rolls should be about thirty inch. The siding can be placed on skids beyond the track and edged on main saw when in the way. The swing saw should be five feet ahead of the longest log that can be cut. Two men behind the sawyer will place the lumber, the bill stuff being dumped on skids beyond the swing saw and stock lumber taken to destination on car or lumber truck.

A word here about lumber cars. Few of them are labor savers. They are constructed very small, heavy wheels, running on rough bearings in wood at that. I have seen many such cars require two good men to get back in the mill. The wheels should be large and light running in babbitted boxes, with a frame just heavy enough to keep the car square on an iron track.

One man with two cars can take care of 15,000 feet of lumber. One man can do the piling, which will be about one-half the mill cut where bills are cut, otherwise two men will be required. Then a boy to fire and all goes along well. The slabs are cut into four-foot lengths, as most suitable for lath. The surplus may be kept away with a cart or carried out on a separate dumping car to a place out of the way, where most of edge trimmings must go.

While edging up, the log deck man assists in placing siding on carriage, the sawyer and setter placing it. The sawyer will have ample time at noon or evenings to attend to machinery. By using a good inserted tooth saw a few moments "pointing up" will be all that is required of him, while the setter can change teeth when necessary.

I recently saw a letter from a reputable firm which is cutting 50,000 feet per day of yellow pine with an inserted-tooth saw, using "shot-gun" feed. They would not have a solid saw. This is an exception, but it is not impossible with the right style of saw.

## FORESTS AND DESTRUCTIVE INSECTS.

**T**HERE can be little doubt but that insect pests as a general rule attack only those trees which have been debilitated and weakened, of which state some of them are good judges. As a remarkable instance of the instinct shown by an insect, it may be mentioned that the writer, when exploring timber land on the Nashwaah river, in New Brunswick, having to camp in the woods, built his fire against a large spruce, which he used as a back log. The ground was covered with moss, and the roots exposed. On them the fire was laid. The tree when left next morning was badly scorched. Two or three days after, on returning to this place, the borer was seen hard at work depositing her eggs in the doomed tree.

W. Somerville, lecturer on Forestry, Edinburgh University, says : "The most common cause of the production of a large quantity of breeding material is

a severe gale, or a succession of severe gales, as we experienced in Scotland some years ago. At that time, as will be remembered, whole woods were leveled with the ground over wide areas of country, and some years afterwards the timber could neither be cut up nor marketed. That, then, was an opportunity for *Hylurgus piniperda*, as well as for all bark beetles, to increase at a prodigious rate, and one which the results show that they were not slow to avail themselves of."

Precisely the same thing has occurred in New Brunswick, where, after a heavy gale, by which large extents of forest were blown down, great destruction was made among the standing trees by bark beetles, so much so that on one brow among 100 spruce logs but 10 were found to have been cut from living trees, the other 90 having been destroyed by beetles. The forests which suffered most after the gale referred to, which is locally known as the "Saxby," were those consisting of large trees which had been cut among. Where lumbering had been carried on for some time and the larger trees cut away, little harm was done by the beetle, due no doubt as well to the circumstance that the trees in the latter instance were not so tall, and consequently not so obnoxious to the effects of the gale, as to the fact that as there were fewer trees standing on the same area of ground, they would be better supplied with sustenance from it than the original forest would have been had it remained intact, and thus the tree which had been cut among were endowed with sufficient vitality to resist the insects' attack.

Spruce woods gain much by being cut among and the larger trees removed, since the danger of attacks from insect is thereby lessened, and light and air being more freely admitted, the growth of the remaining trees is greatly facilitated thereby. EDWARD JACK.

Fredericton, N. B.

## THE MANUFACTURE OF SPOOLS.

**A**S MAY well be imagined, the immense number of spools used and thrown away every year requires that the business of making them should be conducted on a large scale, and with facilities for rapid production. Birch wood is preferred. The wood is first sawed into sticks of four or five feet long and seven-eighths of an inch to three inches square according to the size of the spool to be produced. These sticks are thoroughly seasoned. They are sawed into short blocks and dried in a hot air kiln. At the time they are sawed, holes are bored perpendicularly through each block which is set on end under a rapidly revolving, long-shanked auger. Next, one whirl of each little block against some little knives that are turning at lightning speed, fashions it into a spool according to the pattern desired, and that, too, at the rate of one second for each set of knives. A row of small boys feed the spool making machines by simply placing the blocks in a spout, selecting the best and throwing out the nobby and defective stock. The machine is automatic but there are some things which it cannot do, hence the employment of the small boys above mentioned. After the spools are turned they are placed in a large drum and revolved rapidly until they have taken on a fine polish. For some special purposes they are dyed yellow, black or red, according to taste. When one sees a spool of thread marked "200" or "300 yards," it does not signify that the thread has been measured, but that the spool has been gauged, and is supposed to have that amount of thread upon it.

The Interior Department at Washington has ordered a permanent government post to be established on the Rainy river, near Fort Francis, 150 miles north-west of Duluth, for the purpose of watching timber stealers from Canada.

## THE CARE AND ABUSE OF SAWS.

SECOND only to the proper tension of the saw is the care of the teeth, and the want of it is responsible for much of the bad sawing seen in almost every saw mill. Here is where the tramp filer gets in his work, being only a degree less mischievous than the tramp hammerer. He generally "knows it all," and has a lot of pat technical phrases picked up while hanging around some saw manufactory or by listening to some good workman. These he hurls at the head of the defenseless proprietor or manager with such oracular gravity and assurance as to impress him with his vast knowledge of saws, an illusion which generally lasts till there is not a single saw in the mill that will do good work. With a fairly good sawyer, who can make some suggestions as to the shape of the teeth, now and then, the agony may be prolonged; but it generally winds up with having all the saws sent to the repair shop, under the impression that something is the matter with the tension, or, at least, that the fault is anywhere but with the teeth.

The tramp hammerer and filer are a gold mine to the repair shop, the proprietor of which seldom takes the trouble to report to the saw mill owner the imposition he is subjected to, though he must be fully aware of it.

A circular saw may have pretty bad teeth and still do fair work, provided there is a good man at the lever, who knows when and how to favor it, and provided the power behind it is sufficient and the speed is high and well maintained. But a tooth once out of shape is bound to grow worse, until it will absolutely refuse to make merchantable lumber, or even any lumber at all. There are so many different ways in which a saw tooth may be wrongly dressed, that but a few of the more common ones will be mentioned here.

A very common and glaring fault is in swaging. The tooth, to work easily and smoothly, must be so shaped that it will cut like a chisel used to cut across the grain. It was stated in a former paper that the cutting edge of the tooth should be dressed at right angles with the face of the log. A careless hand may swage one corner longer than the other. If the outside corner be the long one, it will not have the bad effect it will if it is the inside corner, provided always that the opposite tooth is swaged the same way, even though only the two teeth are so swaged; but the next two teeth will have an extra amount of work to do.

If the pair of teeth are thus filed, they will present an inverted V shape to the wood, and leave a ridge in the centre of the kerf for the next tooth to cut away in addition to doing its own work.

A good many filers pooh pooh so small a fault, but there is just where the trouble begins. It is seldom a single abuse of a saw that renders it unserviceable, but many little abuses working together, the avoidance or correction of which marks the skilled workman.

A common fault is in swaging the teeth, with the swage held at such an angle that the force of the blow comes on top, so as to turn the tooth upward. This causes the tooth to strike the wood at an angle leading into the log, as though in beating out the farther side of a mortise the chisel were held with the handle toward you. This gives the tooth more of a pulling hold on the wood than it can cut, causing it to break its hold, thus tearing, jamming, pounding out the sawdust instead of cutting it out as it should.

To illustrate this, take a framing chisel and work out the farther side of a mortise. Hold the handle toward you, the straight side of the tool being from you. Drive it into the timber a half inch or so, then push the handle from you, and continue to drive the chisel down until you have pushed it back to a perpendicular, and then note how much force it required. You will observe that you lose nearly the entire effect of the leverage of the wedge shape of the chisel in forcing out the chip, and instead of it coming out mechanically, by the force of the blows of the mallet, it has to be pried out by muscular force. Compare that force with that required to be exerted on from 6 to 10 saw teeth, swaged as described, all driven into the log at once, and with the much deeper hold of a 10 or 12-inch feed, in a large log. The extra steam power thus wasted is often enormous, and with an engine just large enough for the work, with the saw in good condition, is often the

source of much vexation and unmerited growling at the engineer.

But by far the most serious result is the straining effect on the rim of the saw, resulting in a stretching that will soon take the "dish" out of the saw, and if persisted in producing a "slack rim." This latter condition will be first detected by a rattling of the saw between the guides, necessitating their tightening up to the point of heating the saw plate, and finally such a flapping of the tail of the saw as to impair the smoothness of all the lumber sawed.

If only a part of the teeth are of this character, as often happens, the filer not knowing enough to detect the difference, or at least not realizing the effect, the action of the saw will be peculiar, an alternate catching hold and letting go that will have a jerky effect on the engine, and cause the saw to give forth a whir-ur-ing sound, as if it were out of balance, or some of the teeth were longer than others, making it "out of round."

Occasionally a filer will discover he has swaged his teeth in the manner described, and has sense enough to know it will have a bad effect, and will endeavor to correct it by filing. This can be done, of course, but it involves extra labor and much unnecessary filing away of the points, and a loss of a portion of the effect of the swage. With abundant steam power behind a saw swage as here described, it will work right along, doing fairly good work, with now and then a broken tooth when the vicious hold happens to be on a particularly wiry knot, until at last the constant straining and pounding produces the effect on the tension already noted, and the saw has to go to the repair shop to be rehammered, but never again to do as good work as before.

Everybody concerned outside of the repair shop, will wonder what caused the slack rim, the true cause not being suspected. In nine cases out of ten the blame will be saddled on the sawyer, on the supposition that he has allowed the saw to get some wrench or twist. And right here is an illustration of the theory stated in a former article, that a sawyer should at least have a theoretical knowledge of filing. In that case he would be able, not only to vindicate himself, but to detect the errors of the filer, who, if not amenable to advice or suggestion, could soon be made to give place to a better man.

There is a difference of opinion as to how the corners of a tooth should be left. Some very good filers, supported by very good sawyers, claim they should be left as sharp angled as possible toward the body of the tooth. Others, and probably the majority, swage out pretty full, and file the side angle as near a right one as possible, keeping the tooth nearly full as far back as the amount of swaging will permit. A third class swage sufficient to allow of dressing the side of the tooth to an exact right angle to a slight depth, say one thirty-second of an inch, then reducing the angle more or less sharply. A fourth class, generally experts, swage out fuller still, and make a right angled side surface of twice or three times the depth last described. Every style of tooth has its strenuous advocates, with strong arguments to back them. The first assert that the less swaging the better, its effect being to drive the particles of steel back one upon the other, compressing them and then spreading them sidewise, and that the repeated compression and expansion will tend to crystallization, rendering the edge liable to crumble, which will more than offset the lack of wear in the sharp corners.

The second class argue that the sharp, angular corners, while requiring much less swaging from regular wear, are more liable to be broken by contact with any hard substance, like a knot or foreign body like gravel, imbedded in the bark or sap; that they wear off so fast, under the most favorable circumstances, as to require such frequent swaging as to amount in the end to really much more than if swaged out fuller at first.

The third class repeat the arguments of the second and go a step further, asserting that the danger of crystallization is very remote and not to be compared with the danger of breakage of corners to which all angular-sided teeth are liable. In addition they call attention to the wedge action of the tooth that loosens the particles of wood the cutting edge has severed; that with the sharp angular point, the wedge acts only to the ex-

tent of the thickness of the body of the tooth, which, being so much narrower than the cutting edge, leaves a triangular ridge from the line of the cut of one tooth to that of the next, and that, notwithstanding the wide cutting edge, the kerf is practically not wider than the thickness of the saw plate, the lumber thus being left with an uneven surface; while the narrow kerf between the grooves made by the points of the teeth renders the saw liable to being heated, even to the extent of ruining the tension.

This is a correct theory that is perfectly easy of demonstration by watching the action of such a saw while in the kerf, and noting the ridgy surface of the lumber it makes. The advocates of this class of teeth claim that the small amount of square side they get gives them practically the full benefit of the wedge in breaking squarely off the particles of sawdust, at least to such an extent as to give sufficient width to the kerf, to avoid pinching the plate, and also to give room for the tooth to clear itself. They, too, deprecate further swaging on account of the danger of crystallization, claiming they have found the limit.

The fourth class emphasize all the claims of the third, except as to the sufficiency of the wedge action. They scout the idea of danger of crystallization, and claim that all the straight side that can possibly be obtained is necessary to the perfect action of the saw, and that if it were possible to carry the full width of the edge back to a line with the cutting point of the next tooth, perfection would then be reached; that the tooth would wear long enough to do as much and as hard work as the carpenter's framing chisel, and the surface of the lumber would be as smooth as though jackplaned.

The claims of these four classes of teeth, when analyzed, lead to the following conclusions: The sharp angular pointed are the poorest made. They are bad for the saw, as they require such frequent filing from constantly getting the corners knocked off. They are liable to uneven wear, thus causing unequal work of the several teeth. The liability to heat the saw and the tendency to make rough lumber should forever debar it from any first-class mill. No sawyer, with any regard for his reputation, will submit to using a saw with such teeth, as, in nine cases out of ten, he will be blamed for its faults.

The second class are only a degree better than the first, and should be ruled out, though there are probably more such teeth in use in this country than of any other kind, a majority of inserted teeth being of that shape.

The third class of teeth are a compromise between the extremes. They do good work, hold an edge nearly as well as the longer sided ones, and keep their corners out in pretty good shape till the whole edge is dulled. The teeth wear evenly, thus preserving the roundness and consequent balance of the saw. A fair amount of the wedge effect is obtained, and, up to a certain amount of feed, the lumber made is fairly smooth. But beyond that point there is the same fault as in the other—ridgy lumber—more or less pronounced as the saw is favored or crowded by the feed. The kerf, however, is shaved out fairly wide, so there is seldom heating of the saw from pinching.

With the machine swages in use in many saw mills, it is probably difficult to go beyond this point until some improvement is made.

It will be apparent to the reader that this theorizing is largely based on the use of the hand swage, and this is a correct basis when it is remembered that with all the improvements in them, and their cheapness, the machine swages are not in use in more than 20 per cent. of the mills of the country, and automatic sharpeners or filers in not more than 50 per cent.—*Northwestern Lumberman.*

A firm at Dresden are successfully manufacturing tool handles and shafts from compressed paper chemically prepared. They are very hard and firm and have the additional advantage of being non-conductors of heat. Another German firm is making pulleys of pasteboards pressed by hydraulic power, having an iron core and casing. They are supposed to take up less room, generate more friction and are water proof.



## WOOD-WORKING CHIPLETS.

BY JOB.

**M**R. OWNER, call down your fireman. Don't you know that those vast volumes of dense black smoke that issue from your smokestack every 20 or 25 minutes, means something very serious in the way of a draft on your profit account? Ask your fireman why such volumes of black smoke, which is simply coal heated enough to drive it apart, but not enough to burn it, should be sent out to blacken the landscape. Ten chances to one he cannot tell you why. He may not even know that these regular eruptions mean a loss to you.

All the same they do. It is a double-ended loss, too, a regular two-edge-cut-both-ways knife that chisels away your profits at a fearful rate. In the first place, he shovels in too much coal at one time, having let the fire burn too long without replenishing. In the second place, he throws in the fresh coal in a heap here, a heap there, and a heap over yonder, instead of spreading thinly and evenly over the whole bed of fire. The unusual quantity of cold fuel reduces the heat in the furnaces, lowers the steam pressure for a time, and causes a loss. Then the heaps become heated enough to allow unburned coal to pass up the chimney. That causes another loss. In this way the bad method of feeding the fire simply uses up the heat, which ought to make steam out of the water in the boiler, to volatilize and carry away the coal that ought to be used in making steam.

See? You ought to if you do not. Your chimney belches out thousands of cubic feet of half gaseous coal every day, wasting the money you paid for the coal, shortening the service it performs for you, subjecting your plant to unnecessary wear and tear and dirt, and all because your fireman, left to his own devices and ignorant of what he is doing, goes on shoveling coal in the wrong way, at the wrong time, and in wrong quantities. Call him in. Call him down.

The subject of firing leads directly up to the question of the general building, use and treatment of steam boilers. Here is a table compiled by an inspection and insurance company, showing the number of explosions of steam boilers, giving a summation of the results of bad construction, bad treatment and bad management in general for 12 years:—

Year.	Explosions.	Killed.	Injured.
1879.....	132	208	213
1880.....	170	259	535
1881.....	159	251	313
1882.....	172	271	359
1883.....	184	263	412
1884.....	152	254	251
1885.....	155	220	278
1886.....	185	254	314
1887.....	198	264	388
1888.....	246	331	505
1889.....	180	304	433
1890.....	226	244	351
Total....	2,159	3,123	4,352

Of course, this is only a partial table, made up from the records of a single company, with no attempt to make it absolutely complete. It is an instructive, really a destructively instructive, showing. Look over it and then set about finding whether your own steam plant is not in such a shape that it is a promising, or threatening, candidate for a front place in the record of catastrophes for 1891. Foresight with steam is far better than hindsight.

## NATIONAL FORESTRY PAYS.

**T**HE government of France has expended \$30,000,000 so far in re-forestation, and it is estimated that \$34,000,000 more will be necessary before the mountain slopes are re-clothed and the farming lands reclaimed, and all because the State did not interfere in time to prevent the consequences brought about by the greedy private owners. It is not generally known that in Europe every State owns more or less forest property, which under a competent administration, yields a large revenue. Prussia appropriates annually \$8,000,000 for her present administration, but she receives \$14,000,000 in return, leaving a net revenue of \$6,000,000, and all German States, as well as Austria, Italy and France have a net income of \$1.50 to \$4 from every acre they have in forest growth.

## ADVICE FOR YOUNG FOREMEN.

**F**IRST, don't be self-conceited; this is one of the commonest diseases of young foremen. At first, no doubt, you will be modest and careful enough, but after one month has rolled by, and you find the shop is not a total wreck under your management, modesty will very likely give way to a satisfaction that will make you ridiculous if you don't check it. Don't ever let in the idea that you have done better than others could do, and don't imagine that the shop couldn't run without you. There are lots of sensible men in every shop, who size the boss up very correctly. They will know just what your calibre is, and you can't fool them. Therefore don't try. Don't ever pretend to know it all. If your men are convinced that you are fairly well informed they will respect you. But they will instantly detect and despise any false pretences in this line. Moreover, when you really do know a thing, show it by your actions rather than by words.

Don't be afraid to ask advice when necessary. There are men in that shop, I'll be bound, from whom you can learn a big lot. Therefore, when you are "stuck" on some problem that would puzzle anybody, don't be ashamed to seek counsel of some level-headed man in the shop. He can probably help you; and, if the problem is a hopeless one, you at least have the comfort of good company in your perplexity. But don't ask advice habitually or needlessly; and, if possible, counsel in each case with the man who is to do the work in question. Don't go over his head to some one else; it hurts his feelings, and don't work well. When, for instance, a difficult pattern is to be made, full of novel and peculiar features, consult the head molder as well as the pattern-maker. Above all things, don't fall into the habit of always leaning on the same man, or the same two or three men for advice; it will ruin you all.

Be calm and deliberate. No matter what emergencies arise, don't act, or give orders, or talk at all without giving yourself time to think. I have often had a perplexing job come into the shop, or a bad break occur, late in the afternoon, that paralysed me. In such a case I always looked it over coolly and deliberately, and gave no sign of what I thought of it, or what I intended to do. In fact, I didn't know; but, ten chances to one, an hour's study after supper, when I had time to think, would clear away the difficulty, and in the morning I would go at the job so easily that they all thought I intended from the start to do it that way.

In such cases it generally pays pretty well to note carefully and silently any suggestions that may be dropped by any of the men; I have learned a lot in this way.

Keep your temper, don't ever speak roughly to your men; no treatment can be too good for a good Canadian machinist. If a man is not good enough to be well treated, you don't want him. And don't ever get angry at a hard job, or a poor tool, or an accident—it makes the men laugh at you.

## STEAM MOTIVE POWER IN 1700.

**T**HE discoveries which are from time to time made in the Egyptian tombs authorize the belief that many of the inventions and machines of the present day were known to the ancients and used by them. A correspondent who is curious in such things, sends us the subjoined extract from the "History of China," Pere du Halde, which was published in 1741 (folio edition). It is certainly nothing less than a miniature locomotive and steamboat which was here noticed. The extract is taken from a description given by Du Halde of the various inventions made by the Jesuit missionaries in China for the instruction and amusement of the Emperor Kanghi, who died in 1722. The inventions there described were about the beginning of the eighteenth century:—"The pneumatic engines did no less excite his Majesty's curiosity. They caused a wagon to be made of light wood, about two feet long, in the middle whereof they placed a brazen vessel full of live coals, and upon them an eolipile, the wind of which issued through a little pipe upon a sort of wheel, made like the sail of a windmill. This little wheel turned another with an axletree, and by that means the wagon was set a running for two hours together; but for fear there should

not be room enough for it to proceed constantly forwards, it was contrived to move circularly in the following manner: To the axletree of the two hind wheels and at the end of this beam another axle was passed through the stock of another wheel, somewhat larger than the rest; and accordingly, as this wheel was nearer or further away from the wagon, it described a greater or lesser circle. The same contrivance was likewise applied to a little ship with four wheels; the eolipile was hidden in the middle of the ship and the wind issuing out of two small pipes filled the little sails, and made them turn around a long time. The artifice being concealed, there was not heard but a noise like wind, or that which water makes about a vessel."—*The Engineer.*

## THE BOTANY OF TREES.

**T**IMBER trees are known botanically as exogens, or outward growers, because the new wood is added underneath the bark outside that already formed. The whole thing consists of: *a*, Pith in the centre, which dries up and disappears as the tree matures. *b*, Woody fiber, or long, tapering bundles of vascular tissue, forming the duramen or heart-wood, arranged in rings, of which one is considered to represent a year's growth, and interspersed with medullary rays or traverse septa, these consisting of hard, flattened plates of cellular tissue, known to carpenters as silver grain, felt, or flower, and showing most strongly in oak and beech. After the tree is a few years old, the heart-wood becomes comparatively dry and hard from the compression produced by the newer layers. *c*, Albunum or sap-wood, which is the immature woody-fiber recently deposited. In coniferous trees the sap-wood is only distinguishable when dry by a slight greenish tinge; when wet, it holds the moisture much longer than the heart-wood, and can be detected in that way. *d*, The bark, which is a protecting coat on the outside of the tender sap-wood. It receives additions on the inside during the autumn, causing it to crack and become very irregular in old trees. The mode of growth is as follows: In the spring the moisture is absorbed and rises through the stem as sap to form the leaves; during summer the leaves give off moisture and absorb carbon, which thickens the sap; in autumn the sap descends inside the bark, and adds a new layer of wood to the tree.

## NOT CARELESSNESS.

**A**N IDEA as to what opinions some practical men have as to what is, and what is not carelessness in the management of a steam boiler, is furnished by evidence recently given by an expert engineer, when under examination in regard to a boiler explosion. He was asked, "How did the explosion occur? Was it on account of carelessness?" He replied "No, *there was no carelessness about it.* The boiler was simply worn out." So that running a worn out boiler, liable to explode any day and to kill a few dozen people, was not carelessness in the sworn judgment of an engineer! Probably he thought it showed carefulness. It certainly proved that more care was taken to create a terrible risk than to avoid it, and that carefulness over a few dollars caused criminal carelessness about human life, as do most boiler explosions.

## TRADE NOTES.

The following is the description of a new two-spindle borer just constructed by the Cant Bros. Co., of Galt, Ont: It is designed to perform with accuracy and in one operation, that class of work in which two holes can be bored at any given distance and angle, as in dowelling, chair, cabinet and other similar work, thus effecting a very great economy of time and labor. In most of those hitherto constructed, the angle has been from the horizontal to the perpendicular, one bit being thus brought exactly above the other. But in this one the two bits are mounted in an adjustable head which swivels around one of them, so that they may be set at an angle from the horizontal line of the table. The range of adjustment is from a horizontal to a perpendicular.

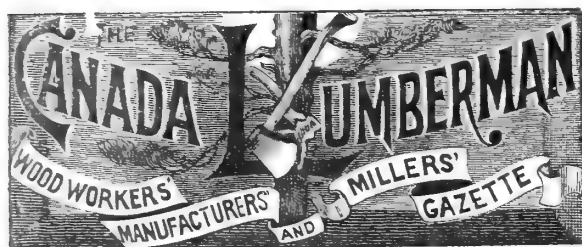

PUBLISHED ON THE FIRST EACH MONTH BY  
ARTHUR G. MORTIMER.

OFFICE:  
75 CANADA LIFE ASSURANCE BUILDING,  
TORONTO, ONTARIO.

TERMS OF SUBSCRIPTION:

One Copy one Year, in Advance, - - - - - \$1.00  
One Copy six months, in Advance, - - - - - 50

Foreign Subscriptions \$1.25 a Year.

Advertising Rates Furnished on Application.

#### POLITICAL AND COMMERCIAL MORALITY.

IT should be possible for a citizen of the Dominion to express an opinion on the revelations at Ottawa, made during the present session of Parliament, and in doing so not to have laid at his door the charge of partizanship. And yet the thoughts of our people, and many of the thinking people, are so honeycombed with partyism, that it is difficult to write or speak on political corruption, and not have a party interpretation placed on one's words.

Neither political party can afford to throw the first stone at the other, for unfortunately the scandals that fill the air, and which in too many instances have developed into hard realities, have not been confined to either political party. The one act does not in any way off-set the other, though here the disposition is to work the "saw off" method, which is a demoralizing method, however applied. We say that it is unfortunate, that this demoralization has been general in its character, because it reveals under-methods of conducting the business of the country that the more unscrupulous of politicians have always said were common to both parties, but which the better citizens had hoped had not obtained so strong and sure a foothold on Canadian soil. Now it will be good manners to say less, for a time at any rate, of the purity of Canadian politics in contrast with those of other countries.

We are not encouraged in history, either ancient or modern, to expect the best ensample of things moral, from those who sit in high places. Yet the people will look to those who rule over them for suggestions as to right ways of acting and living; and there is more than a grain of wisdom in the old saw, 'like father, like son, like master like servant'. The truly loyal citizen, for he only is loyal who is loyal to truth, must regret with deep and sincere poignancy, that in the politics of this country the ideal set by those in high places has been of this demoralizing character.

The question has a commercial side, that should come home with force to businessmen. The revelations referred to have shown to what extent dishonesty—for this is the Anglo-Saxon of the matter—has been practised, not alone by the men placed in positions of honor by their country, but by the employee who has been engaged by these men to do certain work, and been paid to do it. We know how any business man would have dealt with these people had they been in their employ and been guilty of like offences. But the point we aim at is this: Mercantile business, however it may be with politics, is built upon the one foundation stone of confidence, one in the other. It is not capital that gives strength to business; it is the confidence that business men have in one another—in their ability, their judgment, their energy, and above all their honesty. When this confidence is shaken down comes the whole fabric, like a house of cards. Men in the employ of the government of the country cannot accept presents from contractors, commissions and bonuses from those to whom they have given government orders, and do this thing continuously without these influences being felt in the regular channels of commerce. Employees, those who are not servants of the government, but servants, it may be, of some large lumber company, will be tempted and influenced by the example set them, to abuse the trust placed in them, for their own personal gain. Peculation, em-

bezzlement and breach of trusts are not unknown quantities in the commercial world to-day. Happily they are the exception—though unhappily not as exceptional, as they should be—but once set moving and the evil will spread like a prairie fire.

This is a view of the matter, that business men cannot afford to ignore; and while the LUMBERMAN takes the broad view, that as citizens we should each and all rise in our strength and 'lend a hand' to whosoever is honestly desirous to purify the political atmosphere, it insists with every emphasis on stamping out this business dishonesty, because of the general hurtful influence it must create in commercial circles everywhere.

#### FREE TRADE IN LUMBER.

IN our correspondent's column we publish a letter from a well-known citizen of Algoma, in which he makes several direct enquiries relative to the question of free trade in lumber. In the early months of the year when lumber circles were agitated on this question, we devoted considerable space to the subject. A reference to the files of THE LUMBERMAN, by our correspondent, or any other reader interested, will furnish, in a large measure, an answer to the enquiries now made. Then it was supposed, that the question would come before Parliament at its first session, and on that account it took rank as a live question of the day. Parliament has since met, and we have had the announcement of the Premier that the matter will not be introduced in the House until another session; that it is likely to be a factor in the reciprocity negotiations with the United States' government in October next.

This is the immediate position of the question—it is not to-day in practical politics. Approaching it as a question of the future, though it may be the near future, and referring to our correspondent's letter, we may say, speaking broadly, that we believe that the concensus of opinion among lumbermen, is that entire free trade in lumber with the United States would be helpful to the general interests of the trade in both countries. At present, if it is not paradoxical to say so, this free trade is only partial. Our logs go into the States free, but our lumber, though not taxed as high as before, still has the impost of one dollar placed on it. This fact no doubt operates to a measurable extent, and more particularly in some localities than others, against the manufacture of lumber in our own country. It would seem likely, that if there were entire free trade with the United States, that the American lumbermen, who become purchasers of our logs, would prefer to manufacture their lumber at the mills adjoining where the logs would be cut and ship in this shape to their own side of the lines. It has already been shown in these columns that the shipping rates by vessel from the North Shore are sufficiently favorable to the shipper in that locality to influence him to do this. It will strike the average man as an unbusiness like method to take the logs away from the mills, that are at their door, so to speak, when these logs, before being marketable, have to be made into lumber: providing the duty in the case of both logs and lumber was removed.

We think of one influence that might operate against this course; the American lumberman is in many cases owner of his own mills on his own side of the lines; it pays him best to keep these mills running; he has local interests to serve; and he would be willing to pay the expenses of towing the logs to his own mills.

Facts are clear that at present our logs are, in no small number, going across the border. This spring the Midland and North Shore Lumber Company sold their limits to an American firm, Merrill & Ring of Saginaw, Mich., \$225,000 being, we believe, the sum paid, and this winter the new owners will cut a considerable amount of timber; and in the spring they are more than likely to tow this product to the States, there to be manufactured into lumber. The people along the north shore of the Georgian Bay naturally feel grieved at this condition of affairs. But until we have free trade in lumber, it is difficult to suggest a remedy. Fortunately the conditions are local and not general. Get away from that particular section of the Georgian Bay, marked on the one side by Sault Ste.

Marie and on the other by Parry Sound, and we find our lumbermen sending the manufactured lumber by rail into the States, and not shipping logs.

This has to be remembered in discussing the question of free trade in lumber: we have not the whole "say." Friend McKinley has to be considered. Senator Flint warns us, that when making a bargain with the Yank watch which way he holds the stick he is whittling. If he whittles inward to himself he is making the best of the bargain. If he whittles outward some one else is getting the bargain. We have to remember the whittling stick and the whittler in this matter.

#### WORKING UNITEDLY.

TWO events of recent occurrence in the lumber trade serve as practical illustrations of the advantages to be attained by united effort on the part of the members of this trade. Our reference is, in the first instance, to the labor boycott in the city of New York, when in May last the Lumber Handlers and Lumber Truck Drivers' Association of that city endeavored to force the lumber dealers to come to their terms. Without going into particulars, it is enough to say that the end sought was, as in all like cases, to obtain better terms from their employers, and failing to accomplish this by more amicable methods, the objectionable resort of a strike and boycott was employed. This step was resented with vigor by the Lumber Trade Association, and with complete success. There were features of the strike, that furnish suggestive matter for an article on the relations of employee to employer, and of working men to workingmen's unions; but our purpose here in referring to the matter is simply to show to the lumber trade, that there is only one way of meeting a difficulty and that is by all pulling together. The end to have been attained might have been any other than meeting an employees strike; it might have been to accomplish some reform or meet a difficulty within their own ranks; whether one or the other, if the trade had been divided success could not have been expected.

A more recent illustration comes from the lumber trade of England; not a fight this time with labour, but a battle in Parliament with the railway operators of the "tight little island." Elsewhere we give particulars of the trouble, and for this reason do not need to particularize here. The outcome is asked: not entire success; and it would appear, for the reason, that the trade were not throughout the battle acting as a united body. It is true that when, within the past few months, the gravity of the situation was realized, they quickly got close together and worked as one man. Back in 1889, however, when it was known that the trouble was upon them, and then it was that their forces should have been brought together, and careful thought, the outcome of concerted action, have been given to the question, the trade, to borrow the words of an English lumber contemporary, were found at "sixes and sevens." It is pleasing to know that even at the eleventh hour, something has been accomplished.

No question is before the Canadian trade to-day to stir up the fires of enthusiasm that usually seem needed to bring any body of men of any particular class together. Were a question of this kind to assert itself are the trade ready to meet it? And after all, are there not matters that call for "talking over" together? All through the past season there has been an undercurrent of dissatisfaction among the trade, because of the tendency to cut prices and otherwise to draw away from safe and careful methods of doing business. We do not say, these are crying evils of the trade, but they are of sufficient importance to call for a little consideration; and no better time than the present could be found. The country is on the eve of the most prosperous fall's business that has greeted the people of Canada for many years. The lumber trades will certainly reap the gain that will come from the country's splendid harvest. How far the profits of this extra trade will be theirs will depend on what plans they shall adopt to secure these profits.

We are impressed with the thought, that it would be a good thing for the lumbermen of this province to get together in convention early this fall and talk over trade matters. Why not?

# EDITORIAL NOTES

THE *Northwestern Lumberman* of Chicago warns manufacturers of tierce staves and headings to give Chicago a wide berth, except when advised that stock is wanted. Tierces have reached such a beggarly price that they can be made and sold only at a loss, and 20 cents is all the journeyman cooper gets, at that.

THE millmen's strike of St. John, N. B. is in the meantime at an end. The *Globe* of that city says: "Apparently a *modus vivendi* has been reached between some of the millmen and some of the owners which ought to be satisfactory to the former. Practically nine hours are admitted to be a day's work, and under that the mills will resume, leaving to the future to decide the rate of wages to be paid. The ratification of the terms is in the hands of the Millmen's Union. They appear to be satisfactory to all who have heard of them."

RECENT figures issued by the United States Department of Agriculture show a very great increase in the production of lumber within the past ten years. The total annual product of all kinds of material is about 25,000,000,000 cubic feet, equal to a solid bulk of a mile square on the base and a little more than one-sixth of a mile high. It is equal to the annual increase of 500,000,000 acres of forest in fair condition. The value is about \$1,000,000,000, being ten times that of the entire gold and silver output, three times the product of all the coal and other minerals, and nearly three times the farm value of the wheat crop. It exceeds the gross income of all the railroads and other transportation companies. Ten years ago manufacturers of all kinds held the first place in importance as measured by dollars, agriculture second, and forests and products ranked third. The lumber industry now occupies the second and possibly the first place.

OUR knowledge of the behavior of American timber under stress is based upon very incomplete and antiquated series of tests, and until very recently no attempt had been made to supply a want so keenly felt by every engineer and architect who has to deal with wooden construction. The rules of Gordon and Hodgkinson, as applied to wooden pillars, are very old: Mr. Trautwine has done some good work, but his experiments are confined practically to pine, and Charles Shaler Smith, in his excellent formula for the breaking load of square or rectangular pillars, also limited his experiments to white and yellow pine. Mr. Killkardy has tested long pillars of Riga and Dantzic fir; and other scattered oata, of more or less value, are to be found. But the first exhaustible series of tests of American woods ever attempted is now in progress at the testing laboratory of the Washington University, as directed by Prof. J. B. Johnson. These tests are being made under the auspices of the Forestry Division of the U. S. Agricultural Department.

AN American contemporary "desires to enter a protest against the promiscuous use of the term 'lumber mills,' instead of saw mill, planing mill or otherwise, as the case may be. Sometimes one is meant for 'lumber mill' and sometimes the other. In a trade sense a saw mill is where lumber is manufactured, and it is confusing to call a planing mill by any other name. A shingle mill, stave or heading mill, or any saw mill which does not manufacture lumber, should be definitely designated, where there is a desire to give information that can be understood. If there were uniformity in the use of the term 'lumber mill' it might be regarded admissible, but as now used it is a sort of omnibus term that is more or less inane." In Canada the lesson might be extended still further. With the average local newspaper the bare word "mill" is made to cover every conceivable place that can boast a smoke stack. We are told improvements have been made at John Jones' mill, or that the mill at Jackson's corners has

been burned down, or that a new mill is being built at Scugog, but the imagination is left to fill in the blank telling what class of article is to be manufactured within the four walls of the building named.

A MAINE firm that handles thirty-seven millions of spruce yearly, says, that for the next ten years the bulk of the spruce timber in Maine will be made into pulp. Spruce, they say, makes tougher paper than poplar. The vastness of Maine's timber wealth is probably realized by few. Every year now 500,000,000 feet of logs are cut in this state. On the Penobscot River, logging got its first start in 1816, when Maine was still a province of Massachusetts, and in that year 1,000,000 feet of lumber were surveyed at Bangor. By 1831 the output of the river mills had increased to 30,000,000 feet. It is estimated that prior to 1832 there were sawn on the Penobscot 200,000,000 feet of lumber; in the period from 1832 to 1855 inclusive the output was 2,969,847,201 feet, while in the thirty-five years since, 5,892,197,717 feet have been manufactured at the river mills and shipped from the port of Bangor, making a grand total of 9,062,044,918 feet of timber that have been taken from the forest bordering one great water course of the state since the inception of the industry in 1816. Undoubtedly spruce is King in Maine.

EVERYTHING we are told has been created for a good purpose, and we can not hold that the Omnipotent is else than omnipotent and question the word as given to us. Perhaps it serves as an active illustration of the other statement that is found in Divine record, that in many things we see, as through a glass darkly. For when we read that a peculiar insect is creating havoc by destroying the foliage, which is a thing of beauty, and in turn the tree, which is a thing of utility, the most orthodox are apt to become doubters. A recent newspaper dispatch from the State of Pennsylvania has brought the word that a peculiar worm has been discovered among the hemlock timbers of that section of country. The lumbermen had noticed that the tops of the timbers on the mountain were turning brown, and on investigation it was discovered that the defected trees were covered with myriads of worms. A remarkable scene is presented in the "choppings," where the bark peelers are at work. The worms are swarming about the men by the millions, while on all the trees from Coudersport to Port Allegheny, miles and miles of trees are turning brown, and ruin is threatened to vast lumber interests of that section. The worm that is doing the damage is of the "measuring worm" species, about an inch long, and nearly an eighth of an inch in diameter. Reports from Glen Hagel, Elk county, and from the east side of the county, state that the same worm is devastating the hemlocks there. A crisis confronts the whole population of the entire hemlock region of New York and Pennsylvania. The worm is steadily advancing and spreading and working destruction with inconceivable rapidity.

ENGLISH lumbermen are greatly exercised over certain clauses that have been introduced into the railway Bills passed at the present session of the British House of Commons. It would appear that the matter of railway rates and charges of the various British railway companies have for years been in a chaotic condition. As far back as 1883 Parliament made a movement to bring order out of chaos, the opinion being quite general among members of parliament and in commercial circles that it was absolutely necessary that the powers which parliament had conferred upon railway companies should undergo revision and codification. In 1888 Parliament took steps in this direction. The railways were called on to submit a classification and schedules of their proposed maximum rates, to the Board of Trade. Arrangements were then made for traders to submit their objections to the propositions of the railway companies. From August 1888, up to the present the matter has been under the consideration of a special committee, eventuating in the bill now passed, which, so far as the clauses affecting the shipment of lumber are concerned, is of an extremely radical character. The proposition is, that lumber which has hitherto been shipped by measurement is

to be shipped by weight; and other changes are made in the mode of classification that will have an injurious effect on the trade. The force of some of the changes will be better understood, "when" to use the words of *Timber*, of London, England, "we assert that besides fixing several impossible conditions, it was proposed in some instances to increase rates and charges of lumber by no less than 200 per cent., which if imposed in practice, would have rendered the carriage by rail, of the description of timber effected, a matter of utter impossibility." The whole usage of the trade has been clustered around the methods of the railroads of carrying lumber by measurement; and we can well understand the indignation that has been aroused by the present innovation. A courageous fight was made before Parliament, not with very great success, for the Bill, slightly amended, has passed the Upper House, and received the Royal assent. But the trade are thoroughly aroused, and they will as one man, push forward the agitation, hoping at the next session of Parliament to have the obnoxious legislation revoked.

A POPULAR, and there would seem to be good reasons for saying it, a wise admonition of the day is, "learn every boy a trade." It is well known that the professions and commercial pursuits are over crowded. Of course there is room "up top" in all these callings, but only the few can get there, though all can try, and the most unlikely, apparently, often succeed. The mechanical trades are not so crowded, and employment in these can frequently be obtained when the doors are closed on other sides. To employ a colloquialism, "a trade is a handy thing to have by one." Can one learn every boy a trade? Not as readily as the simplicity of the question would suggest. A clause is to be found in the regulations of the labor organizations of the day, which restrict the number of apprentices in each shop or factory. One may make application at a shop to have his boy apprenticed to some given trade, and their may be room for him, or what is just as likely, the maximum number of apprentices has been reached, and the boy cannot be placed there to learn the trade he would wish. It is not difficult to understand the argument from the labor side for this restriction: too many apprentices, too many journeymen; over supply of journeymen, a reduction in the standard of wages. All the time a fundamental principle of political economy is forgotten, viz: that the demand will certainly regulate the supply. The father who is considering the question of placing his boy to a trade, will not seek that trade where he knows that two men are to be found for each one who is wanted. He does not do this under the apprentice restriction clause, he would not do it were this clause an annulity. The existence of this restriction to-day bars out many a desirable youth from learning the trade of his choice. It has a hurtful moral effect upon the ambitious workman, who says to himself: "My bread and butter is sure enough. It is not because I am a better workman than my bench mate, that I am here to-day and obtaining certain wages; the union fixes this thing regardless of the individual. Why should I strive to improve myself in my work? I would gain nothing by it." We do not need to look far afield to see trouble and injustice arising from these conditions constantly. They confront the man, who has not a direct interest in either the plans of the capitalist or the labor union, further than that general interest in the commonwealth which makes him anxious to see every citizen a better citizen by having the opportunity and encouragement given him to make of himself all that is make-a-ble. In Pittsburgh, Pa., troubles arising out of these conditions have led the Builders' Exchange of that city to establish trade schools where boys will be taught the bricklaying trade without any restrictions; and our contemporary, the *Builders' Gazette*, of that city is exerting its influence to have trade schools established to meet like necessities in other trades besides that of bricklaying. Nor is this proposition confined to the people of Pittsburgh alone. We find other localities moving on similar lines. Just as the evils of the system are general, so may we expect that the remedy, when once carefully worked out, to be just as wide in its scope.





"IN REGARD to the statement in an American paper," said Mr. John Donogh, "that heavy purchases of Canadian pine of common grades by American lumbermen, has forced down the price of Michigan pine in the eastern markets about \$1, I don't think there is anything in it. We are into these markets all the time, and our experience has not shown us that any such reduction exists, when one wants to buy. About home trade, August has been a dull month, so much so that we have called in our salesmen, but we could hardly look for anything else in the country with farmers very busy. I think that trade will be good this fall."

Among the shippers of Canadian hardwoods, who are doing an encouraging export trade, is James Gordon, of London, Ont. I had the opportunity of a few words with this dealer a week ago. "I ship in considerable quantities," said he, "to Glasgow. Lately I have been developing a satisfactory trade in broom handles, that gives promise of an encouraging growth. The matter of freights gives us some trouble. The Grand Trunk railway are not as considerate of western shippers as they should be, and when we do bring them any ways nearly to time, it is only after a good deal of pressure."

I dropped in on Mr. Geo. Hastings, one of our city lumbermen, the same day that the census returns for the Dominion had been published. "The showing is a bad one," said he. "The money that we have been throwing into worse than sink holes, *vide* Ottawa revelations, wants to be employed in intelligent and energetic ways for peopleing this country. We know where the money has gone, but we don't do anything with the fellows who got it. How you or I would have fixed them if they had played any such business in our offices. But you ask about lumber. Things are dull. There has been precious little doing this summer. I don't anticipate much activity this fall. Even if the farmers have more money than usual, the season is too short for them to do much in building. In any case they have a good many old scores to wipe off, the accumulations of several bad harvests."

"Selling timber limits to American capitalists," said Mr. John Bertram, one of the largest Canadian operators, "is not a bad thing for the workingmen. From the day Americans took hold of our limits in the Spanish River section, now some time since, wages of teamsters and other workingmen have been increased. They pay the same wages here, that they have been accustomed to give in Michigan, which is higher than Canadian wages. I have on my desk now a telegram from one of our managers in the north, asking for instructions on this very point. He has a gang of men waiting engagements, but before they will go into the woods they expect the same wages that American firms operating in the section are paying. So you see, the workingmen are really gainers, to at least this extent, through American capital being invested in Canadian timber. Of course a good many logs cut are towed across the border, and our saw mills lose the work on them, but all the money necessary to get them to this point is expended in our own country." "You ask me," continued Mr. Bertram, "what stock I take in the agitation for forest preservation. Not much on the lines one usually hears talked. Those who write and talk on the subject seldom have more than a sentimental or theoretical knowledge of the question. I will take them into the woods and show them thousands of young trees, the result of a natural second growth, too young for years to come to cut, but which if allowed to remain unimpaired mean untold timber wealth to the country. The danger is that before these trees reach a period of utility, the bush fire will have gotten hold of

them and this wealth will be wiped out in the flame. The kind of forest preservation that is needed is that which will provide the most complete protection against the fire touching these limits. This is to be done by the government supplying a perfect service of fire rangers. Coming back again to Americans working our limits, they are great people to do things with a rush. An American will clean out the limits he owns in one-quarter the time we do. We are not in so great a hurry as he is to get the timber all cut. One advantage, however, exists in this method: he lessens the risk of having his limits destroyed by fire. You see there are two ways of looking at nearly every question."

I heard it remarked in conversation the other day, the reference being to a gentleman recently appointed to a high position in the affairs of the country, that it would not be an easy matter to approach him for information concerning his particular department. He was set down as a pretty gruff fellow, and if he did not feel 'right,' he would make short work of those who might have occasion to do business with him. It is a misfortune, it occurs to me, for any man to be so built, and especially a man, whose position makes it necessary for him to meet frequently with his fellow men. All this is by the way, suggested by an interview I had a few days ago with Aubrey White Esq., Ass't Commissioner of Crown Lands for this Province, who is one of the men, that is not built after the fashion here described. A most affable and come-at-a-bleman, he is on this account, as well as for his special qualifications, eminently fitted to occupy the important position of Deputy-Administrator of Crown Lands. Mr. White had only returned a few days from a tour of inspection in the Rainy River territories, and I was anxious, in the interests of LUMBERMAN readers, to obtain his impressions of this country. "Our main purpose in taking the trip," said Mr. White, "was to learn for ourselves the 'lay of the land,' and from actual observation, to be able to speak of the conditions, resources and possibilities of these territories. The party consisted of four, the Hon-Commissioner Hardy, Provincial Secretary Hon. J. M. Gibson, A. Blue, Esq., mining director, and myself. We were all immensely pleased with appearances. The lumbermen report having had a good season's trade. They ship altogether west of course into Manitoba and the Territories. And whatever they may have done hitherto, they are enthusiastically hopeful of the trade ahead of them. These hopes are built on the great crop of this year—if it is not blighted any way by frost. It was a remark of almost every one, as nightfall would appear, 'I wonder if we will have frost to-night,' and when one considers the immense interests at stake, not simply local, but as affecting the whole country, we can all appreciate the burden of this thought. I do not know that the effect has been felt to any appreciable extent yet, but the trade in lumber in that section being confined, to Manitoba and the Northwest Territories, one can foresee a possible glut in the market, or a cutting of prices to a dangerous extent, if British Columbia lumber should be pushed with too great energy into these provinces. I don't think, however, that there is any doubt, but that the product of this province better meets the requirements of the Manitobians. Yes there is a lot of timber in this section. I dare not commence to put it in figures the quantity is so great. There will be a large cut this year. I was surprisingly impressed with the conditions of the land in the Rainy River section. It is an excellent farming land, and I should say capable of producing a gratifying yield. Truly we do not know what are the resources of this Province."

I came across an interesting representative of the lumbering industries of this country a few days ago. By name, J. McDonagh; residence, Thorold, Ont; birth, an Irishman, and a typical son of the Green Isle; a man who can go back in lumbering in this province a full half century. "Yes," said he, "I cut plank for the old Welland canal locks, as far back as 1843. I commenced business on my own account in 1854, and have been at it ever since. My trade in those days was largely with ship builders; our shipments went to Ogdensburgh, Oswego and Kingston. But there is no

money now to the lumber trade in ship building. Iron has taken the place of wood. Our cut was chiefly of oak timber, though in my time I have cut millions of feet of pine." Mr. McDonagh's early years were surrounded with no small measure of romance and adventure. "I read with interest," he remarked, "what you tell in the columns of THE LUMBERMAN each month of the work of Mr. Donogh and other modern representatives of the trade in Canada. I want to meet these younger men some day and have a chat with them on lumber matters. I tell you what, they had not the hardships to put up with that fell to the lot of the early settlers in this country." In 1849 Mr. McDonagh was taken bad with the California gold fever. "Forty-two years ago," he continued, "I crossed the plains of California. With some others I made the journey on foot from St. Jo to the Sacramento Valley. That's work for you. In 1850, the day the battle of Waterloo was fought, sixteen of us, all British subjects, stood on the highest summit of the Rocky mountains and had a grand view of the country around us. I was four years in California, and for two years, outside of our own party, there was not a man who could speak English. Never was a day sick all the time I was away." Mr. McDonagh is an enthusiastic Britisher, and says he was glad to return to British soil, which he did at the end of four years, located again in Thorold, and has run a saw mill there from that day to the present. All who struck the California fields in the fifties did not come back rich men. Our Irish friend gathered in a good deal of the "dust" of those days and brought it along with him to Canada.

The account in this page last month of the "wonderful find" of the bone of a buffalo that had been incased in the heart of a tree cut in the Assiniboia section a short time since, which had been there for 170 years has started several curious "finds." Mr. E. C. Grant, manager of the Ottawa lumber Co., of Ottawa, writes that he has in his possession an old Indian tomahawk, which has the following history attached to it: One afternoon while a white pine log, about 25 inches in diameter, was being run through the stock gate, it was noticed that the saws had come in contact with some hard substance in the log breaking a couple of the teeth and otherwise damaging the saws. The man in charge of the gate, immediately stopped it and had the log drawn out. When it was cut into he expected to find part of a cant dog or something of the sort, but after cutting well into the center of the log, what was his surprise, to find embedded near the heart an old Indian tomahawk, which had evidently been left sticking in the tree, which had grown completely round it. On either side of the tomahawk can be noticed the grain of the wood which has eaten well into the steel, and on the top are the cuts where the saws had worn into it when the log was being cut. By information obtained from different sources, it has been ascertained that, from the old fashioned pattern of the tomahawk, and the depth that it was embedded in the log, that it must have been stuck there at least seventy-five years ago. The story comes from Galt of a large silver maple recently cut on one of the streets of that town. The heart was found to consist of a stick, about the size of a walking stick. How the stick got there is a mystery, but having by some means done so, the tree appears to have grown round it, taking it completely in, but keeping it distinct and intact from the new wood with which it was surrounded. A short time ago a large pine log was being sawed at the Jesse Cox's saw mill, Seymour, Ind., when the saw struck some hard substance with a clash. The engine was stopped and the side of the log was chopped into and a whole horseshoe was found, the outer end of which had been struck by the saw. The tree had been sawed down in the old Fair grounds in the north-east part of the city. The shoe was located about three feet from the end of the log, and there were twenty-six yearly growths over the outside part of the shoe, so that it is safe to say that the shoe was nailed to the tree for a hitching place for horses not less than forty years ago. The outside of the tree was smoothly grown over, and there was nothing to indicate the hidden shoe save an indistinct snarl in the bark. Who says there is nothing interesting in the life of a lumberman?

## QUALIFIED AS CULLERS.

NAMES OF THOSE QUALIFIED TO DO BUSINESS UNDER THE ONTARIO CULLERS' ACT.

THE following have passed the necessary examinations and are recommended as possessing the requisite skill and knowledge to warrant their being licensed as saw-log cullers under the provisions of the Ontario Cullers' Act. The examinations were held at the towns and cities named below:—

At Arnprior—Wm. G. Austin, Renfrew; John L. Bremner, Admaston; W. H. Bromley, Thomas Bromley Pembroke; George R. Baulke, Aylmer; W. G. Boland, Eganville; Hyacinthe Caillin, Arnprior; John A. Campbell, Galetta; James R. Campbell, Pembroke; John L. Close, Arnprior; Patrick Drum, Belleville; Patrick Draper, Quyon, Que.; John Ellis, Westmeath; Alex Ellis, Arnprior; Wm. A. Fraser, Pembroke; Wm. Fairbairn, Calabogi, Alex, Fraser, jun., Westmeath; H. A. Fraser, Foster Fraser, Pembroke; Nelson Guertin, Petawawa; Robt. W. Gordon, Noah; J. Gaveau, Pembroke; Densmore Hopkins, Abiram Hopkins, Kingston; Dennis Halferty, Eganville; Thos. A. Low, Renfrew; Michael Mulvihill, Arnprior; Andrew Moran, Rockingham; John Mulvihill, M. J. Monaghan, John B. Monaghan, Arnprior; Benjamin Mason, Westmeath; Edward Mackey, Alex. McLaughlin, Peter McLachlin, John McPhee, Arnprior; Hugh McPhee, Renfrew; Wm. B. McKendry, Arnprior; Duncan McFarlane, Renfrew; J. D. McFarlane, Stewartville; Alex McFarlane, Renfrew; Alex McNabb, John C. McManns, Arnprior; Peter W. McLean, Sand Point; Duncan McGregor, Burnstown; Donald McCallum, Arnprior; Robert Niblett, Osceola; James Niblett, J. F. Richie, Robert Ramsay, Robert Scrim, Wm F. Sinn, Arnprior.

At Belleville—F. G. Richardson, M. P. Kinsella, C. M. Richardson, Peter Pomery, John Loso, Frank Jay Golden, C. T. Marsh, A. J. Campbell, Trenton; James Hartt, Gilmour; Dennis Callaghan, James Manning, Trenton; Norman A. Green, Gilmour. Thomas James Barry, Hastings; P. J. Andersen, Campbellford; A. E. Simpson, Lakefield; Joseph Claremont, Campbellford; Timothy Kenny, Enterprise; John McIlroy, Madoc; J. A. McWheeler, Richard Richards, Tamworth; Henry Kirk, Trenton; Wm. Scanlan, Enterprise; Philip Martin, Stoco; John Kirby, Belleville; Robert Kennedy, Marmora; Middy Lenayre, Campbellford; James Hayes Enterprise; John Grant, Flinton; Alex. Howe, Queensborough; Thos. Barry, Millbridge; Frank McEvoy, Campbellford.

At Bracebridge—D. C. McKay, Baysville; Finlay Johnson, James Carson, Bracebridge; James T. Bayley, J. C. Anderson, D. H. Sutherland, Gravenhurst; Evan Richey, Brentwood; Dugald McLeod, Gravenhurst; John McEachren, West Gravenhurst; Joseph Chew, Gravenhurst; James D. Shier, Bracebridge; C. N. Taylor, Gravenhurst; R. H. Salmon, Baysville; John Hutton, Hutton House; Wm. E. Hutcheson, Robert Lee, John Spanner, Huntsville; B. F. Kean, Orillia; W. R. Spooner, Kattine; W. D. Thornton, Longford Mills; Geo. F. Morris, Frank's Bay; T. J. Doyle, Eau Claire; J. Q. Adams, Longford Mills; M. M. Anderson, Almonte; Job E. Smith, Cache Bay; J. S. Morris Hoff, Arnprior; James S. McPherson, Rama; Geo. J. Overend, Longford Mills; John W. Millar, Huntsville; John Dickson, Sundridge; Hector D. McInnes, Daniel McLean, Malcom McKinnon, Thomas Pattinson, Bracebridge; Thomas B. Tait, Walter Freeston, Burk's Falls; Edwin B. Appleton, Bracebridge; Peter McDermott, Orillia; Singelton Brown, Bracebridge; James Latimer, Frank's Bay; T. A. Roberts, Huntsville; T. W. Humphrey, Gravenhurst. Abm. Boland, Cartier; R. O. Miller, Gravenhurst; Archibald Menzies, Burk's Falls; Gilbert Truster, Trout Creek; Robert Jackson, Brechin; Archibald McKinnon, Bracebridge; J. W. McFarlane, A. J. Young, Cache Bay; Alfred Lloyd, Severn Bridge; James D. Allan, Bracebridge; Wm. Young, Severn Bridge; Mark Malloy, Baysville; Frank Newton, Gravenhurst; Wm Watson, Huntsville; Andrew Ross, Longford Mills; Mark Longford, Baysville; Robert Campbell, J. M. Campbell, Bracebridge; John Humphrey, Gravenhurst; Ridley Appleby, Kattine; Robt. D. Brown, Port Sidney; Asa Mutchbarker, Rosseau Falls; A. C. Train, Rowan Mills.

At Mattawa—William O'Connor, Nobsonging; John Tuffy, Cartier; James W. O'Neil, North Bay; Napoleon King, Mattawa; Silas Brown, Klocks Mills; William Durrell, Nobsonging; Ferdinand Kelly, Mattawa; Samuel Volin, Nobsonging; Christopher L. McCool, Cartier; Wm. J. Snaith, Sidney C. McDonald, Mattawa; Francis Henry Thompson, Nobsonging; Lewis McNamara, Klocks Mills; Andrew P. Ebert, Pembroke; Daniel A. McIntyre, Klocks Mills; John Anderson, Cartier; Alex. B. Gordon, Pembroke; Fred. A. H. Thompson, Callander; Wm. A. Fraser, Mattawa.

At Ottawa—Henry Bell, H. M. Beach, John E. Luby, W. P. Malone, L. R. Kirby, James Riddell, Ottawa; George A. Riddell, Rochesterville; George Spargo, J. B. Souliere, Ottawa; James A. Sheels, Carlton Place; A. Carruthers, Hintonburg; Paul F. Blanchet, Andrew Albert, John W. Durrill, Ottawa; Wm. McCormack, Pembroke; John McPherson, Ottawa; Roderick

McDonald, Pembroke; Milton Knox, Andrew O'Brien, James McFadden, Wm. J. Culder, Ottawa; John O'Connor, Hintonburg; Wm. G. Purcell, Ottawa; James G. McIntosh, Carleton Place; Chris. McKay Forbes, McLaren's Depot; F. W. Brooks, Mackey's Station; J. C. Cole, James Locknan, Ottawa; Joseph R. Hogarth, Pembroke; W. H. Farrell, Ironside, Que.; Arthur Green, Alfred Allen, Joseph W. Ward, A. Stremer, Ottawa; A. A. Rice, Hull Que.; D. B. Rochester, Ottawa; L. Loughrin, Pembroke.

At Parry Sound—W. H. Lynch, Collingwood; F. A. Laurie, Parry Sound; E. C. McKinlay, Toronto; Geo. M. Aikins, French River; Louis W. French, Bying Inlet; William Wilkinson, French River; James Ludgate, Peterboro; A. H. Huckson, John E. Waldie, French River; Percy J. Vigrass, Dufferin Bridge; William Cameron, Collins Inlet; R. W. George, R. W. Danter, John Gardiner, Parry Sound; Dean Udy, French River; Samuel E. Green, William Newburn, Jacob Lutz, Parry Sound; Edwin Hurd, Hurdville; James McDonald, John McClland, Parry Sound; P. K. Perry, W. H. Smyth, Bying Inlet North; Thos. H. Irwin, Geo. W. Webb, R. H. McClland, W. B. Beatty, Parry Sound; Louis G. Randall, D. Kitchen, French River; Robert J. Clarkson, Robert J. McNabb, Thomas Wilcox, Parry Sound; Peter F. Sheehan, Loring; John Purvis, W. S. Bird, J. H. Linton, E. Clair Fitzgerald, Frank A. Shields, Parry Sound.

At Penetanguishene—Thos. B. Shaw, Waubashene; J. M. Bird, Muskoka Mills; David Hall, Lovering; A. D. Grosette, Muskoka Mills; George Ross, Waubashene Robert Caan, Midland; J. F. Beck, Penetanguishene; J. C. McFailand, Port Severn; August Groupe, Penetanguishene; Geo. Murray jun., Waubshene; C. E. Dawson, W. J. Lovering, Robert Buchanan, Coldwater; J. P. McDonald, French River; Nelson Sage, T. G. L. Barnes, Muskoka Mills; A. Jones, Victoria Harbor; Allen McPherson, Longford; Joshua Hill, Midland; A. G. Breed, Penetanguishene; Edwin Letherby, Midland.

At Peterboro—George Lenton, Peterboro; John J. Pearson, Lindsay; James Aylward, John C. Bell, Peterboro; Thomas Sadler, Lindsay; Thomas Johnson, Bobcaygeon; William Simpson, Hall's Bridge; Charles Hartlev, William Maniee, Peterboro; George Murray, sen., Waubashene; Nathaniel Crowe, Bobcaygeon; John Coburn, Lindsay; Owen Fortune, Trenton; James Porter, Uphill; George Cochrane, Martin W. Brandon, James Swanston, Peterboro; Maurice Lane, Bobcaygeon; Edward McGrane, Lindsay; James Goulais, Peterboro; Thomas Chamberlin, J. P. Davis, Bobcaygeon.

At Port Arthur—Archibald M. McGillivray, Wm. J. Margech, Port Arthur; Joseph Maughan, Fort William.

At Rat Portage—Donald McLeod, jun., Keewatin; Wm. Murray, Rat Portage; John L. Archibald, Percy T. Roberts, Charles Grayson, Keewatin; Alexander Cameron, Patrick Albert Smith, Archibald M. Johnston, David Fraser, Norman; Donald M. Rose, Robert Hamilton, Hugh Carson, Thomas A. Magee, Richard J. Morgan, Rat Portage.

At Sudbury, Spanish River Mill and Sault Ste. Marie—Richard S. Donally, Sudbury; Joseph Vincent, Warren; Peter P. Munroe, Comanda; George W. Bartlett, Warren; John C. McCormack, Sudbury; Alex. D. McNabb, Warren; Edward G. Graham, John Paterson, Charles Ford, Wahnapiatae; Henry C. Gladstone, James Mindoch, Cook's Mills; Wm. Cassidy, John R. Wells, Charles Anderson, Little Current; John K. Cameron, Spanish River; Melvine Carson, Little Current; John France, Collins Inlet; Duncan McDougall, Bracebridge; Alex. R. Dobie, Blind River; Robert Garson, Thessalon; P. B. Wali, Cheboygan, Mich.; James M. Adams, Sault Ste. Marie; Thomas G. Wigg, John F. Boyd, Stephen W. Crawford, Alex. McNabb, Thessalon; George S. Thompson, Lindsay; Darcy Oliver, Wahnapiatae; Jeremiah Kelly, Sudbury; Frank R. L. Chrysler, Webbwood; Hector R. McDonald Thessalon; Wm. D. Ritchie, Little Current; James Griffin, Spanish River; Duncan D. McGillivray, Algoma Mills; Archibald J. Campbell, Little Current; Wm Devine, Cook's Mills; John McNamara, Bying Inlet.

IT IS poor argument to say, because mills and factories well equipped with fire extinguishing apparatus, occasionally burn, that it does not pay to put in such apparatus. Hundreds of fires are thus extinguished every year, of which nothing is heard; whereas, had the places in which they started not been prepared for fire, the loss of entire establishments would have resulted. Good mill management demands the most effective fire extinguishers obtainable.

Twenty-five per cent. economy in the use of steam does not mean the same degree of economy in fuel. Owners of steam plants have been deceived in this way and very often look upon meritorious devices with suspicion because they did not use one-quarter less coal after buying a device recommended as above.



## THE QUESTION OF DUTY AGAIN.

*Editor Canada Lumberman:* As you are aware, the lumbering industry in Algoma is one of its most important industries, and being desirous of seeing this industry prosper and become as beneficial to Algoma as possible, I would be pleased to receive your opinion upon the probable effects of free trade between this country and the United States in all lumber believing you to be intelligently informed on this and all matters touching this particular industry. At present our millmen are encouraged to sell the logs, instead of cutting them into lumber, to the Americans, owing no doubt to the difference between the American import duty on lumber and the Dominion export duty on logs. I believe some ninety million feet of logs have been already exported to the United States mills to be sawn. Supposing there was free trade between the two countries in lumber and logs, or, in other words, the American import and Canadian export duties were removed, do you think it would encourage American mill men to move their mills nearer the limits and ship the lumber by vessels, or would it have the effect of sending more logs to the American mills to cut there? Would it be cheaper for the American lumbermen to tow their logs over there or cut the logs up here and send the sawn lumber over there in vessels?

Hoping to hear from you soon and trusting I am not intruding too much on your valuable space.

Thessalon, August 25, 1891.

ALGOMIAN.

## BLACK TEAK IN AFRICA.

VARIOUS writers who have visited Africa attest the enormous wealth of the forests of the country, which seem to abound in valuable hardwoods. Among other woods a recent writer mentions the African black teak. To quote his language: "The black teak is an entirely new wood. It has the full appearance of teak in tree, leaf and bark, grain or growth. But it is nearly a dull black color, and splits just about the same as the yellow teak. What I have seen of it has been in small trees, but I am told that there are large forests of it up the Kasiah river, mostly trees in size of from 12 to 20 inches over the stumps, ranging from 20 to 60 feet to first limbs. This is the timber chosen by the natives for bows and arrows, spear handles, paddles and anything where a good tough piece is needed. I consider it a better timber for spokes, felloes, handles, etc., than the best American hickory or oak, or white ash, as it is very hard when green, dries still harder, and is not much of a timber to warp. I have used it on axe handles and other places for over a year, and it has proven far better than the best imported split axe and shovel handles. It is very spring, and that is why it is used for bows and spear handles."

An engineer has reversed the method of cleaning out boiler tubes. Instead of pushing the soot with a scraper, or blowing it into the back connection, a device with a tapered nose fits snugly into the tube at the front, which draws the soot from the tube and forces it along to the stack. The device is shaped something like a steam jet with a circular opening, steam blowing through the device and inducing a strong draft through the particular tube being operated upon. In this draft the tubes are cleaned of all loose deposits. The draft is strong enough, it is said, to pick up pea coal and eject it fifty feet."

COMPETENT Sawyer required to handle lever on circular. Address, giving experience and references. THE RATHBUN CO., Deseronto, Ont.

GANG Saw Filer wanted—must be good. Address, giving experience and wages, THE RATHBUN CO., Deseronto, Ont.

## THE NEWS.

## ONTARIO.

—Lumbering is brisk at Petawawa.

—Rankin's mill at Brunel is running over time.

—D. W. Hawkins, saw mill, Grey Eagle, has sold out.

—The tug Shawanago is towing logs from Spanish River.

—Bush fires are plentiful in the vicinity of Maidstone, Essex Co.

—The last drive of logs for the season, on the Petawawa, is down.

—The saw mill at Edgar, which had been closed for a time, is in full operation.

—The mill at Thessalon is running short of logs and may have to close down.

—Messrs. Perley & Pattee, of Ottawa, have a full gang working in their mill.

—The P. S. L. Co's saw mill at Parry Sound, has shut down for want of logs.

—C. Young of Young's point is cutting lumber for the Edison Works, Peterboro.

—The Utterson Lumber Co., of Utterson, have sold their store to a Mr. Brock, of Toronto.

—A shingle machine in Thompson's mill, Orillia, has made a record of 218,000 cut in one week.

—The demand for lumber in the Algoma section is reported on the increase and prices on the rise.

—The Crossfield mill at Sturgeon Bay, is running again after having been shut down for repairs.

—A Wiarton dealer has the contract to supply a London firm with 100 carloads of cedar for paving.

—It is estimated that the cut of lumber at the Chaudiere this year will not be one-half of last year's output.

—Seaman & Newman, of Wiarton, are supplying 1,250,000 feet of square timber for use on the "Soo" canal.

—It is said that about 90,000,000 feet of lumber will be taken out at the back of Spanish River next winter.

—W. S. Greensides, formerly of Mitchell, has removed to Mount Forest, where he will erect a band saw mill.

—Buel, Orr, Hurdman & Co., of Ottawa, have thousands of logs, which cannot be brought down until next spring.

—The Saginaw Lumber Co. have started work in the vicinity of Whitefish, giving employment to a good force of men.

—Buel, Orr, Hurdman & Co.'s new mill on the Chaudiere, which has been idle all summer has commenced work again.

—On the 10th ult. Mr. Chas. O'Neil left Ottawa for the Kippewa, in charge of thirty men engaged for Perley & Pattee.

—Two saw mill proprietors of Nelson have been fined \$20 each for depositing saw dust and mill refuse into Kootenay lake.

—The new shingle mill erected on the site of the one burned down some time ago at Sturgeon Bay is now in active operation.

—Wm. Peter, lumberman of Bay City, Mich., has a representative in Canada just now looking for "good bargains" in Canadian lumber.

—James Johnston, who lost his mill at Utterson by fire in the early spring, has bought a mill site at Rat Portage and is building a shingle mill.

—D. Belleghem, furniture manufacturer, of Peterborough, has purchased the season's cut of elm lumber of C. Young, of Young's Point.

—A boom of logs belonging to McLachlan Bros., of Pembroke, was broken by a wind storm a week ago and sent dashing down the Chats Rapids.

—A large raft of extra fine square timber, the property of Thistle, Carswell & Francis, has created more than ordinary interest at the Ottawa docks.

—E. B. Eddy's big mill, Ottawa, is being altered beyond recognition. A portion of the machinery for the new paper mill has arrived from Vermont.

—The Rathbun Co., of Deseronto, have bought 1,875 acres of timber and mineral lands in the township of Lavant, on the Kingston and Pembroke railway, for \$8,000.

—"Bold Monroe," the able bodied shantyman, of the Upper Ottawa, has completed the work of getting out the drives under his management. He reports the work heavy.

—C. Young, of Young's Point, has sold his season's cut of basswood to Rathbun & Co., of Deseronto. The season's cut of shingles amounting to nearly 700,000 he has sold to a Montreal firm.

—D. H. Cameron & Co., of Ottawa, have secured a site at Liverpool, Eng., and will shortly commence the erection of a large saw-mill to work for both local and export trade.

—Hurdman & Co., of Ottawa, have dispatched a gang of forty-five men to their limits on Laville Creek, up the Kippewa river. The rate of wages being paid is from \$16 to \$22 a month.

—About seven hundred cars of lumber, posts, ties, etc., are handled every month by the yard department of the Rathbun Co., of Deseronto. This excludes all such material moved by vessels.

—Rumor saith that a big American lumber concern of Maine, will remove their entire lumber business to Owen Sound in consideration of a certain grant of land from the municipality.

—Recent rains have helped the drives in the Rainy River section. All drives have now been able to get through, and the drives of Saunders, on Little Forks, of six or seven millions, hung up since the spring, are coming down.

—The Penetanguishene *Herald* states that from July, 1890, to July, 1891, over 16,000,000 feet of lumber have been shipped from that port to the United States. This does not include shingles or lath, of which large quantities have been sent to the same market.

—The schooner *Niagara*, laden with lumber for Burton Bros., Barrie, and bound for Owen Sound, which went ashore about a month ago during a heavy gale, is a complete wreck, all efforts to release her proving futile. The vessel was owned by Robt. Baird, Kincardine.

—Following is the estimated cut of the Lake of the Woods mills for the present season in feet:—

Keewatin Lumber Company.....	12,000,000
Minnesota & Ontario Company.....	12,000,000
Cameron & Kennedy.....	10,000,000
Dick, Banning & Co.....	10,000,000
Western Lumber Company.....	8,000,000
Ross, Hall & Brown.....	8,000,000

These are given as close figures, and may be exceeded before the season is over. The mills are all running briskly, and the demand is large. Cameron & Kennedy operate the Bulmer mill, in addition to their own, the cut in the two mills being included in the figures for this firm. This accounts for the total seven mills on the lake.

—A despatch from Peterborough says:—For several years past there has been dissatisfaction amongst the saw mill owners on the Otonabee and Indian rivers with the water supply. A few years ago a new high dam was built at Young's Point which held the water back in Stony lake, and the Otonabee men claim that since that time a large share of the natural flow into the Otonabee has gone into the Indian river, while the latter interests claim that they are not receiving their former supply, but have had to shut down their mills from lack of water. Superintendent R. B. Rogers got about twenty of the mill owners together the other day, but after discussing the question no conclusion was arrived at. Well-informed persons say that the only way to make the supply of water last is to make reservoirs of the upper lakes which empty into Stony lake. The Government will soon have to deal with the matter.

—In the action of the Parry Sound Lumber Co. against the Victoria Harbor Lumber Co., a motion for an injunction\* was to have been argued before Mr. Justice Meredith, at Osgoode Hall, but the action having been settled by the parties an order was made in the terms of the settlement. The dispute arose in regard to floating logs down the Seguin River, which flows from Mill Lake to Parry Sound Harbor. The plaintiffs had some 2000 logs to take down the river and the defendants about 38,000. The river is narrow and only one drive can go down at a time, and all logs in the river go with it and are assorted at the Harbor. The plaintiffs' mill is situated near the mouth of the river and when the drive, being brought down by the defendants, came to the plaintiffs' mill they wanted their logs sorted out and left there. The river at this point is only 100 feet wide, and the defendants refused to comply with the request on the ground of inconvenience and expense and proceeded to take the drive into the harbor. Some 10,000 logs had been got down when the local judge issued an injunction restraining the defendants from proceeding with the work. By the settlement all logs are to be taken down to the harbor and then the plaintiffs' logs by means of a jack-ladder are, at the defendants' expense, to be returned to the plaintiffs' dam.

—The following is believed to be the basis of settlement between the Ontario Government and the Keewatin Lumbering and Manufacturing Company, generally spoken of as the Mather islands claim. Tunnel Island, situated between the east and west falls became the property of the company, but they are required to expend within three years one hundred

and fifty thousand dollars in improving the water power and on demand of the Government, though not necessarily within the three years, a further sum of one hundred thousand dollars. In addition to Tunnel island twenty acres on the main land north of the track and immediately west of the rapids near Norman is given to the company. Part of the proposed improvement of the water power will be the building of a dam at the west of Norman rapids about fifteen hundred feet below the railway bridge. One very important condition, and in one sense the most important one, in the agreement is that the Ontario Government is to have direct control of the rates that may be levied for the water power, thus preventing any dog in the manger policy in the matter of encouraging any proposed manufacturing establishments. As regards Coney Island the Mathers will be granted one acre each for certain of the summer cabins erected by them but this will under no circumstances cover those put up this season and it is believed that the number covered by this agreement will not exceed six or seven. They do not get Sandy Beach. Mr. Wm. McCarthy who claims Coney Island, interviewed the Minister and received satisfactory assurances from him that his claim would have special consideration, and it is believed he will get the greater portion of what he claims. Captain Brereton will also be granted his claim to the point at present occupied by him.

## BRITISH COLUMBIA.

—C. M. Beecher of New Westminster, becomes manager of the Hastings mill at Vancouver.

—Martin Bros. contemplate moving their saw mill from Harrison River to Hope Slough shortly.

—The Canadian Pacific Lumber Co., New Westminster, have sold out to Ewen, McCormick & Scott.

—Large gangs of loggers have gone north, as far as Port Neville, to commence operations at the various camps.

—The Chilean barque *Hinaostan* is on her eighth trip to South America. She is loaded with lumber from Moodyville.

—Elmer Ward of the recently established shingle mills on the North Arm is building a tugboat to run in connection with his mill.

—The owners of the Mission City townsite are offering inducements to parties to erect and operate a saw and planing mill at that point.

—Cassidy & Co. of Vancouver have received a shipment of about 25,000 feet of redwood from California. It is to be used for mouldings.

—There is some talk of the establishment of an extensive saw mill at Esquimalt, under the auspices of certain Moodyville and other capitalists.

—Galbraith & Sons, new sash and door factory at New Westminster is about completed and work will be started with a number of good orders already booked.

—The Revelstoke Lumber Co. mills are busy in getting material out for the northwest, an order for 15 carloads has been received and numerous smaller orders are being filled.

—A. J. Jamieson, from Ontario, is looking over timber limits here with a view of locating a saw or planing mill at Mission City, with a capacity of 50,000 feet per day.

—The sawmill on the Southern side of LuLu Island is doing a considerable business. This mill will shortly be supplanted by a large mill, preparations for which have already commenced.

—The prospectus of the British Columbia Paper Co. (Ltd.) just issued, states that the proposed capital is to be \$50,000. A site for the mills has been selected on first rapids of the Somas River.

—Though some of the mills on the coast are closed down the Hastings mill is still in operation and announce that they will continue running. They have a large order in from Yokohama, Japan, for shipments by next boat.

—Mr. F. M. York, of the Puget Sound and B. C. Stevedoring Company, who has been the company's manager at Victoria for some time, has been transferred to Vancouver, where he will replace Mr. Betts, who goes to Tacoma.

—The barque *Leonor*, which has been loading lumber at the McLaren-Ross mills for several weeks has finally completed her cargo and will leave immediately for Melbourne, Australia. She carries 628,000 feet of assorted lumber.

—The British Ship *Leading Wind*, sailed from Moodyville 5th ult for Melbourne, Australia with the following cargo: 763,443 feet of rough lumber; 2,500 bdls laths; 8,679 bdls pickets—valued at \$7,326. Deck load consisted of 76,879 feet.

—It is stated that another Stevedoring Company will enter the field to compete for British Columbia work. The head quarters of the company is Port Townsend, but they will contract for the discharging of all vessels in all Puget Sound and British Columbia ports.



—A tax of fifty cents per 1,000 feet of lumber got out from this province has always been charged as "stumpage tax," but in accordance with an order-in-council, dated the 27th of November, 1888, a rebate of 25 cents was allowed on every 1,000 feet exported from the Province. A notice is now inserted in the British Columbia *Gazette* stating that the rebate on the royalty received from lumber exported will be discontinued, the new regulations coming into effect on the 31st ult.

—Mr. L. Woods has returned to New Westminster after an absence of three months with a survey party in the vicinity of Fort Rupert. Mr. W. E. Deveraux, of Victoria, was in charge of the party, which consisted of sixteen men, with Mr. Woods as head chainman. They were absent three months and experienced a rough time. The same party leave Victoria again in about a week's time for the west coast of Vancouver Island, and will be absent about nine months on the same mission.

—The nominal rates for lumber charters are quoted as follows: From Burrard Inlet or Puget Sound to Sydney, 50s; Melbourne, Adelaide or Port Pirie, 60s to 62s 6d; Shanghai, 62s 6d; West Coast of South America, 50s to 55s. For coal freights, presents quotations are: Nanaimo or Departure Bay to San Francisco, \$2.50; to San Diego and San Pedro, \$2.50 to \$2.75. Grain freights are quoted from Puget Sound to U. K., 42s 6d, to 45s; from Portland, 50s., and from San Francisco 40s. to 42. 6d.

—Two old fir log water pipes were unearthed in Victoria by the men engaged in the sewer work. They were found about four feet below the surface, near the corner of Bastion and Government streets. The two pipes were remarkably well preserved. They were laid 37 years ago and were made at Hope mill, a few miles from Yale. They are fir logs, bored out with a diameter of about four inches. The old-fashioned water pipes have served well their purpose and now will be carefully treasured as relics of an early day in Victoria's history.

MANITOBA.

—A lumber yard has been started at Rosenfield.

—Slater & Anderson, of Napinka are doing a good trade in lumber. A Mr. Kose of Rat Portage, it is said, will open another yard here this fall.

—The royalty upon lumber manufactured from burnt timber on licensed lands in Manitoba and the Northwest has reduced from 5 to 2½ per cent.

—A despatch of 10th ult from Seikirk says, that the steamer Red River, just arrived there, experienced rough weather on Lake Winnipeg and lost a barge of 155,000 feet of lumber belonging to Brown & Rutheford. Three Indians on the barge were rescued with great difficulty.

—One of the pioneer firms of Winnipeg, is Dick, Banning & Co., manufacturers of lumber, shingles, and lath, which was established in 1872. Their mills are located at Keewatin, covering an area of 30 acres, and is one of the best equipped in the country. The plant consists of the saw mill, planing mill, lath mill, and dry kiln, the latter being the only one in the country, and has a capacity of 90,000 feet of lumber. They own 100 square miles of timber lands, located on the tributaries of the Lake of the Woods and Rainy river, and operate two steam boats which tow the logs from the camps to the mill. Employment is given to about 100 men at the mills, while a like number find employment in the various camps. The mill has a capacity of 10,000,000 feet of lumber per annum, and the product which consists of rough and dressed lumber, shingles, lath and mouldings, is shipped all over Manitoba and the northwest territories as far west as Regina.

NEW BRUNSWICK.

—John C. Risteen, of Hartford, Conn., has been here in the interests of the American bobbin, spool and shuttle company. He has been looking up birch lands with a view of ascertaining whether it will pay to erect mills to cut spool wood.

—E. D. Jewitt & Co., lumber operators and mill owners, St. John are in financial difficulties, occasioned by the embarrassment of the Boston Branch of the firm conducted under the name of Glendon company, which handled and manufactured their New Brunswick output. Jewitt & Co. cut most of their logs on the tributaries of the Upper St. John and operated a mill at Millidgeville.

—A new industry has been started at York Mills by A. W. Little. Finding a poor supply of lumber for his mill, he has begun the manufacture of excelsior. Poplar wood of which there is a large growth near his mill, is used in the manufacture of this material, which is packed and shipped from Prince William station. The business is paying well and it is likely to be continued for some time.

The saw mill of Robert K. Jewett, of Kesinck, N. B., was destroyed by fire a few weeks ago.



—Over 100,000 trees in forest reserves in South Australia have lately been destroyed by grasshoppers.

—Dynamite is being resorted to in breaking up log jams in many United States' streams, and with it is said, good results.

—Mr. Gladstone is not the only famous woodman. It is reported that the Czar of Russia is very fond of woodchopping.

—The Wilkin Manufacturing Company, makers of saw mills and general milling machinery at Millwaukee, has assigned. The assignee's bond has been fixed at \$400,000.

—A Pacific coast timber and lumber dealer who located a mill in a South American state vows that brush will grow there a height of six feet in one day succeeding a night's rain.

—According to the *Graschdanin* the new law permitting Russians to acquire property in Finland is causing a considerable export to the latter country of wooden buildings in Russian style.

—Under the reciprocity treaty with Spain covering trade with Cuba and Porto Rico, United States' lumber which has heretofore paid a duty of from \$4.60 to \$5 a thousand is admitted free.

—It is said that every month adds from one to three dozen new mills to the number already established in the Pacific northwest, and of these nearly two-thirds are built in Western Washington.

—At Fleming's mill, San Bernardino, Cal., recently was cut a pine log from which 18,334 feet of lumber was cut. The average price of this lumber in San Bernardino is \$20 per thousand feet.

—Enormous fires have been raging in the forests in the vicinity of Toulon, France, and a great quantity of valuable timber has been destroyed. Three thousand acres are already reported as consumed by the flames.

—Padouk, a hardwood from the East Indies, is being used in London, England, as a substitute for mahogany. It is only half the price of mahogany, and some claim that in color, figure, and other qualities it is superior to mahogany.

—Negotiations are going on which may result in the sale of the Mississippi River Logging Company's two saw mills and real estate at Eau Claire river to the Northwestern Lumber Company. The deal would cover property for which the Mississippi Logging Company paid the Eau Claire Lumber Company about 1,000,000 three or four years ago.

—A World's Fair big tree committee has been scouring the woods of Puget Sound region of Washington for monstrous growths, the Northern Pacific having offered to haul to Chicago the largest stick of timber that can be found in the State. The committee, has measured a good many firs; some standing in a bunch were 10, 11 and 14½ feet in diameter, six feet from the ground, and 100 feet to the first limb. Those of another group were not over nine feet in diameter, but 350 to 400 feet high. A single tree of similar diameter, is said to be 200 feet to the first limb. On the north fork of the Nooksack, is a perfect spruce, said to measure 14 feet in diameter, and on the south fork there is a cedar tree, blackened by fire, that is 21 feet in diameter. The same journal furnishes its readers with an illustration of a pine stump 10 feet high and 25 feet diameter, on which are standing and seated 78 persons.

—A measure has just passed through the French legislature which enacts that on and after March, 1892, import duties shall be paid on all wood goods brought into the republic. On timber in the round, 60 centimeters and upward in circumference, measured at the butt, the duties will range from 75 centimes to 1 franc per 100 kilos. On planks and boards, or hewn and sawn timber of a greater thickness than 35 millimeters, the dues range from 1 franc 75 cent. to 1 franc 25 cent. Sawed wood of smaller dimensions will have to pay from 3 to 2 francs. Between now and the imposition of the dues, there should be a brisk demand from France for all descriptions of wood goods, as the duties saved will represent a very handsome profit. According to returns furnished by the British Board of Trade, the imports of wood goods into Great Britain from the United States during the past half year have amounted to 355,946 loads, valued at £826,999, against 248,868 loads, of a declared value of £851,834, for the corresponding period of last year.

A steady decrease is to be noted, during the past eight years, in shipments of lumber from Saginaw. The total shipments of forest products by water from the Saginaw valley during the last month are as follows: Lumber, 57,394,000 feet shingles, 14,350,000 pieces, and lath, 3,230,000 pieces. The total shipments thus far this year to August 1st are as follows: Lumber, 199,325,000 feet; shingles, 38,550,000 pieces, and lath 7,948,000 pieces. Following is the amount of lumber, shingles and lath shipped by water from the valley during the months of July in recent years:

LUMBER.		Feet.
1884	.....	118,638,000
1885	.....	85,387,000
1886	.....	75,623,000
1887	.....	68,849,000
1888	.....	72,521,000
1889	.....	53,862,000
1890	.....	57,554,000
1891	.....	57,394,000

SHINGLES.		PIECES.
1884	.....	27,755,000
1886	.....	11,490,000
1888	.....	11,650,000
1890	.....	8,200,000
1891	.....	14,350,000

LATH.		PIECES.
1884	.....	9,042,000
1886	.....	4,860,000
1888	.....	3,190,000
1890	.....	5,091,000
1891	.....	3,230,000

FIRES.

New Westminster, B. C., has bush fires in close proximity to the town.

Bush fires to a considerable extent are raging in different parts of British Columbia.

For the third time the shingle mill of Abraham Van, Orillia, Ont., has been destroyed by fire.

T. McElwan's saw mill at Bannockburn, Ont., was burned recently. Loss \$2,000. No insurance.

A portable shingle mill, belonging to Mr. Fox, of Mill-bridge, Ont., was recently destroyed by fire.

Bush fires are raging in South Colchester, Ont. Large quantities of cordwood have been destroyed.

Smith, Malcolm & Gibson's planing mill, Seaforth, Ont., was partially destroyed by fire during the past month.

A small quantity of lumber, the property of the planing mill at Chilliwack, B.C., was destroyed by fire on 18th ult.

The steamer *Alderson*, owned by the Georgian Bay Transportation Co., was burned to the water's edge. Insurance \$6,000.

R. Olmsted, of Walters Falls, Ont., has suffered a severe loss by the destruction of his saw mill by fire. No insurance. Mr. Olmsted will rebuild.

The large saw and planing mill owned by John Smith, of Tilsonburg, Ont., was totally destroyed by fire on the 19th ult. Loss \$7,000. Insurance \$2,000.

On the morning of 20th ult., a fire broke out in the planing factory of Galt, Henderson & Co., this city, and consumed almost the entire building before gotten under control.

PERSONAL.

Mr. J. H. Hart, of Sadler, Dundas & Co., Lindsay, Ont., is on a trip to the Pacific coast and San Francisco.

The LUMBERMAN had the pleasure of a call during the month from Mr. J. L. Eaton, of Orillia, Ont.

Miss Annie A. McLean, daughter of M. G. McLean, manager at Vancouver, B. C., for the Pt. Moody Lumber Co., has been united in marriage to A. C. Stirrett, Esq., of New Westminster.

Mayor Eddy, of Hull, Que., has been ill for several weeks from blood poisoning which occurred in a very simple way. A small pimple appeared on his neck and coming in contact with a patent shirt button, which had accumulated a small quantity of verdigris, blood-poisoning set in. His face and neck were badly swollen.

Hon. A. S. Hardy, Commissioner of Crown Lands, Hon. J. M. Gibson, Provincial Secretary, Aubrey White, Esq., Assistant Commissioner, and A. Blue, Esq., Mining Director, have been on a tour of investigation in the Rainy River District. While at Bracebridge, on 7th ult., Mr. White rescued from drowning two children aged five and fifteen, who had fallen into deep water in the lake. Seeing their danger, he, at considerable risk to his own life, at once jumped into the water and brought them safely to land.

TRADE REVIEW.

Office of CANADA LUMBERMAN, }
Aug. 31, 1891. }

THE GENERAL SURVEY.

IT IS a long day since a brighter future loomed up before the people of Canada than meets them at this time, as they stand on the threshold of a new season's trade. Viewing the landscape o'er from every point of vantage, they can with hopefulness sing 'the long looked for has come at last'.

During the month that is just closed unmolested quietude was the vogue. This can easily be accounted for in the city, for August is the holiday month of all the summer months, whilst in the country everyone has been so busy in the fields that they have had no time to come to town.

Locally trade has been quiet and it is not expected that there will be more than a fair trade done in the city this side of spring. A local firm, carrying on a rather heavy contract business is in deep water. At the time of writing no assignment has been made, though a large amount of the firm's paper has gone to protest.

Perhaps at the close of no season have the yards at all main points been so cleared of lumber. In some cases it is difficult to meet present calls. This fact is influencing our lumbermen to prepare for an active winter in the woods.

No element of noticeable activity marks the lumber trade in the Maritime provinces. The strike of last month is off, and the mills are again running. This much gain has been made during the month. The fall season, however, does not open, with strong premonitions of a large trade.

Business in British Columbia, at the present time, is suffering not alone from the loss of trade in South America, caused by the Argentine trouble, but a depression exists just now in Australia which has a tendency to further circumscribe export trade.

Quotations are as follows for cargo lots for foreign shipment, being the prices of the Pacific Pine Lumber Association: Rough merchantable, ordinary sizes, in lengths to 40 feet, inclusive \$9 per M feet; rough deck plank, average length 35 feet, \$19; dressed flooring, \$17; pickets, \$9; laths, 4 feet, \$2.

UNITED STATES.

Reports for this month from leading United States lumber centres indicate some improvement in trade—though not anything, so far as actual present trade is concerned, to make much noise over.

letter that gives emphasis to this. In Boston and New York lumber would appear to possess the sulks. The condition of the crops has inspired hope, of course, that had no existence at all hitherto, but before lumber circles anywhere will feel a strong impetus from the money coming in this way, farmers and store-keepers will have many old scores to liquidate and get out of the road.

FOREIGN.

The English Board of Trade returns for July, which are just published show a drop back of two millions sterling in export in a single month. The figures relating to sawn goods are particularly worthy of attention, the import for July of the present year having been 683,487 lds., as against 834,605 lds. for the same month last year.

Toronto, Ont.

TORONTO, Aug. 31, 1891. CAR OR CARGO LOTS.

Table listing lumber prices in Toronto, Ontario, including items like 1 & 1 1/2 in. Cut up and better, 1x10 & 12 dressing and better, etc.

YARD QUOTATIONS.

Table listing yard quotations for various lumber products such as Mill cull boards & scantling, Shipping cull boards, Scantling & joist, etc.

Ottawa, Ont.

OTTAWA, Aug. 31, 1891.

Table listing lumber prices in Ottawa, Ontario, including Pine, 1st qual., 2nd, shipping culls, etc.

St. John, N. B.

ST. JOHN, Aug. 31, 1891.

Table listing lumber prices in St. John, New Brunswick, including Spruce deals, Pine, Deal ends, Scantling, Shingles, etc.

Montreal, Que.

MONTREAL, Aug. 31, 1891.

Table listing lumber prices in Montreal, Quebec, including Pine, 1st qua'y, Pine, 2nd, Pine shipping culls, etc.

New York City

NEW YORK, Aug. 31.—Business is dull, dull—really dull. A comparison with ordinary seasons makes us feel bad. Nothing is lacking in supplies, and the cost is low. An oasis of encouragement is found in a slightly improved trade with country points; and with a large grain crop, and a hopeful leaning to good prices, we take this circumstance as a precursor of better days ahead.

White Pine—Western Grades.

Table listing prices for White Pine—Western Grades, including Uppers 1 in., 1 1/2 & 2 in., etc.

Albany, N. Y.

ALBANY, N. Y., Aug. 31.—Some large shipments, covering many million feet of lumber, made from this market to New York and vicinity, during the month, have given fresh heart to the trade here.

White Pine.

Table listing prices for White Pine, including 1 to 2 in. good, 1 1/2 to 2 in., etc.

Thirteen Foot Stock Boards and Plank.

Table listing prices for Thirteen Foot Stock Boards and Plank, including 1x10 in., up dressing, 1x10 in., common, etc.

Shingles and Lath.

Table listing lumber prices for shingles and lath, including items like Shingles, shaved pine, Lath, pine, Spruce, Hemlock, etc.

Saginaw, Mich.

SAGINAW, MICH., Aug 31.—Present trade is conducted on a limited scale. Sorting up orders are in order, but nothing more can be said of the lumber trade in Eastern Michigan—as regards the present.

Finishing Lumber—Rough.

Table listing lumber prices for finishing lumber, including items like Uppers, 1, 1 1/2 and 2 in., Selects, 1 in., etc.

Siding.

Table listing lumber prices for siding, including items like Clear, 1/2 in., 3/4 in., etc.

Timber, Joist and Scantling.

Table listing lumber prices for timber, joist, and scantling, including items like 2x4 to 10x10, 12, 14 and 16 ft.

Shingles.

Table listing lumber prices for shingles, including items like XXX 18 in. Climax, XXX Saginaw, etc.

Lath.

Table listing lumber prices for lath, including items like Lath, No. 1 white pine, Lath No. 2 W. pine Norway, etc.

Buffalo and Tonawanda, N. Y.

TONAWANDA, N. Y., Aug. 31.—The predictions in this column last month of a 'fairly lively trade' for August have been verified. A decided improvement has been experienced in lumber around Buffalo and Tonawanda.

White Pine.

Table listing lumber prices for white pine, including items like Uppers, 1 1/2, 1 1/2 & 2 in., Selects, 1 in., etc.

Box.

Table listing lumber prices for boxes, including items like 1x10 & 12 in (No. 3 out), 1x6 & 8 in (No. 3 out), etc.

Shingles.

Table listing lumber prices for shingles, including items like 18-in. XXX, clear, 18-in. XXX, 6-in clear, etc.

Lath.

Table listing lumber prices for lath, including items like No. 1, etc.

Boston, Mass.

BOSTON, MASS., Aug. 31.—Hardly a hopeful word can be written of trade here. It has been one long siege of dullness all summer through; the dullness continues, with seemingly no outlet before the late fall, if then.

get. The demand is not large, yet a lack of stock to meet moderate needs. Walnut is seldom asked for.

Western Pine—by car load.

Table listing lumber prices for Western Pine by car load, including items like Uppers, 1 in., 1 1/2, 1 1/2 & 2 in., Selects, 1 in., etc.

Eastern Pine—Cargo or Car Load.

Table listing lumber prices for Eastern Pine, including items like Nos. 1, 2 & 3, 4, 5, Ship's bds & coarse, etc.

Spruce—by Cargo.

Table listing lumber prices for spruce, including items like Scantling and plank, random cargoes, Yard orders, etc.

Lath.

Table listing lumber prices for lath, including items like Spruce by cargo, etc.

Shingles.

Table listing lumber prices for shingles, including items like Spruce, 18 in. extra, Pine, No. 1, etc.

Oswego, N. Y.

OSWEGO, N. Y., Aug. 31.—There is absolutely nothing new to note from this point. Prices show no change during the month, and the same is to be said of trade.

White Pine.

Table listing lumber prices for White Pine, including items like Three uppers, 1 1/2, 1 1/2 & 2 inch, Pickings, etc.

Siding.

Table listing lumber prices for siding, including items like 1 in siding, cutting up, 1 1/2 in selected, etc.

1x12 Inch.

Table listing lumber prices for 1x12 inch lumber, including items like 12 & 16 ft. mill run, 12 & 16 ft. No. 2, etc.

1x10 Inch.

Table listing lumber prices for 1x10 inch lumber, including items like 12 & 13 ft. mill run, 12 & 13 ft. dressing and better, etc.

1-4x10 Inches.

Table listing lumber prices for 1-4x10 inch lumber, including items like Mill run, mill culls out, Dressing and better, etc.

1x5 Inches.

Table listing lumber prices for 1x5 inch lumber, including items like 6 7 or 8. mill run, mill culls out, etc.

Shingles.

Table listing lumber prices for shingles, including items like XXX, 18 in pine, Clear butts, pine, etc.

Lath.

Table listing lumber prices for lath, including items like No. 1, No. 2, etc.

IMPORTANT TO SHIPPERS.

THE Grand Trunk Railway Company has issued the following circular through district General Freight Agent Mr. A. White: "Our car supply officers say that they are frequently taken at a disadvantage through not being advised of my contracts, or of shippers intention of shipping heavily."

During a high wind on the morning of the 28th ult., a shingle mill situated on Muskoka Bay and owned by A. L. King, was burned to the ground. Cause of fire unknown. Insured for \$2,000.

LUMBERING CASUALTIES.

Peter Swanson, Watterville, Ont., lost two fingers by a circular saw.

A youth named Beauville has had one of his legs badly cut in the mill of Perley & Pattee, Ottawa, Ont.

Geo. Skelton an employee of Orr's planing mill, Stratford, Ont., had two fingers of his right hand cut off on 6th ul.

Charles Gray an employee in Lloyd & O'Connor's planing mill, Ottawa, had the top of a finger taken off by a buzz planer.

Two weeks ago William Wright, of Cardinal, Ont., fell from a pile of lumber 25 feet high breaking his neck and causing instant death.

Caleb George Cliff, contractor for lumber piling at Burton Bros. Mills, Bying Inlet, Ont., was accidentally drowned by falling off a lumber pile.

Joseph Courville, watchman, for the E. B. Eddy Co., Hull, Que, was knocked down by a horse and rig a few days ago, receiving severe injuries.

Moses Wilkinson of Lutterworth, Ont. was badly cut in the arm and side at his saw mill and eighteen hours after receiving the wound breathed his last.

Deseronto, Ont., counts her share of accidents: Alexander Green had his hand badly crushed by the fall of a log. Archie Smith lost the top of a finger.

James Hamilton an employee of the Union factory, Wingham, Ont., received a severe wound in the hand a fortnight ago while working with a rip saw.

Instantaneous death came to Walter Moore of Morton Bros. saw mill, Clover Valley, B. C. by falling on the large saw belt. He was at once carried around the drum and dropped to the floor a corpse.

There are now twelve men working in Thackray's mill on Sparks street, Ottawa, Ont., who at one time or other have had some of their fingers cut off while at work. The latest victim was on Wednesday.

A young man named Charlebois, an employee in the Georgian Bay Co's saw mill at the mouth of the Severn near Midland, Ont. upset in a canoe in four feet of water, and must have been seized with cramps immediately as he lost his life.

What is likely to prove a fatal accident occurred to Dunn Mitchell who was working a capstan at Whitefish, Ont., moving a boom of logs belonging to Howry & Co. A bar slipped, and flying round with considerable force struck him fair across the stomach, shutting him up like a jack knife.

Joseph Gray works the slabber in the Victoria Harbor Lumber Company's mill at Garden Hill, Ont., and was standing in his place on the 28th ult., when one of the other men threw an apple towards him. Not having seen it coming in time to catch it he dodged back and stepped into the hole beside the saw used as a trimmer. As he fell he threw his arm on the saw, the teeth of which cut into the flesh and quite a way into the bone. Amputation may be necessary.

A frightful boiler explosion occurred at Spencer's saw mill, one mile from Walsingham Centre, Ont., on 22nd ult. There was no one in the boiler room at the time except the engineer Clark Branson, and he was thrown 100 feet out into the yard. His death was instantaneous. The men in the mill escaped uninjured, but how they got off with their lives is a marvel, because the mill was completely demolished. The heavy boiler was torn from its bed and thrown, together with many saw about 25 yards.

NEW PUBLICATIONS.

We have received from Mr. H. R. A. Baughman, the author, a copy of his valuable little work, "Baughman's Buyer and Seller." It is gotten up in pocket shape, being well and tastefully bound in full leather. Undoubted labor has been given to the preparation of the valuable lumber tables which the book contains, which show 4,000 different sizes and lengths by which the number of feet in any number of pieces of lumber can be shown at a glance.

A neatly gotten up edition of the Rules and Regulations for the inspection of pine and hardwood lumber as adopted by the lumber section of the Toronto Board of Trade, has been published by the CANADA LUMBERMAN. To every lumberman, really it is a pocket vade mecum, and a copy will be sent to any of our subscribers on receipt of a three cent stamp.



## USEFUL INFORMATION

Always have your boiler covered with non-conducting material, no matter how cheap your fuel may be.

A few accidents about machinery happen from seemingly unfavorable causes, but a great many are the direct result of carelessness.

In the use of oil, uniformity of distribution is as important as the regularity of the supply. A dry spot on a bearing will at once cause heating, and, if allowed to continue, cutting will be the result.

An insurance man of long experience declares that milk is the best obtainable extinguisher for petroleum fire. If milk is not at hand flour will answer nearly as well for putting out the flames.

The same rule which applies to constant feed with pumps holds good where injectors are used; there should always be a stream of water going into the boiler so long as there is a current of steam going out of it.

It is surprising how careless steam pipes will be hung. The majority of cases make no proper allowance for the movement of the pipe by expansion, and as a consequence joints are strained and leak, flanges are broken off and in many cases hangers are pulled out.

Here is another recipe for a mixture for uniting belts: Dissolve gutta percha in bisulphide of carbon to the consistency of molasses, slice down and thin the ends to be united, warm the parts, apply the cement and submit the parts to heavy pressure at least four hours.

A pretty good rubber cement for cementing leather belts can be made by dissolving guttapercha in bisulphide of carbon. It is safe to say that if belts possessed the sense of smell they would never stand a cement of this kind, as the odor is so loud it would, as the old saying goes, "drive a dog out of a tan yard."

An essential requirement for the successful working of an injector is the suction, the same as with any pump, for if not properly attached it causes a great deal of trouble, and more especially when the water is far away or on a lift of twenty-five feet, for then the slightest leak of air will effect the quantity of water if not wholly destroy the vacuum. The injector will lift water at 100 degrees temperature on a lift of twenty-five feet, or 140 degrees temperature on three or four feet lift. Water of a high temperature will not condense the steam; therefore injector will not feed it to the boiler with certainty, but with a small jet of cold water from street pressure, applied close to the injector, hotter water can be lifted, even to 212 degrees, but not delivered any hotter than it would be taken at 140 degrees, as the jet would be used to temper down to that point.

A Mr. Elliott of London, Eng. proposes to solve the smoke problem by condensing the smoke in water and recovering the by-products. To this end he has a tank of water in which are revolving stirrers driven by a small engine or by spare power. By means of a fan he draws the smoke from the chimney and forces it into the water at a point near the bottom of the tank. The smoke and products of combustion are then churned up together in the tank, the solid particles of the smoke and the sulphurous vapors and noxious fumes being arrested in the water. In time the heat of combustion warms up the water and the steam is allowed to escape through a chimney into the air. When the water has become fully charged with the condensed smoke and other matters, it is drawn off and the tank is refilled with water. The charged liquor is to be afterward treated and the by-products due to the combustion of coal are to be recovered. By this means, it is claimed that not only will the smoke nuisance be abated but that a profit will be derived from the operation.

The horse power of steam boilers is a subject upon which something may always be said. It is pretty well understood that the capacity of a boiler is determined by its ability to evaporate water; and the amount of evaporation necessary for a horse power is fairly well agreed upon. But while this furnishes a standard for ultimate resort, it can only be applied to the recorded performance of a boiler in actual use, and the practitioner will still have frequent occasion to approximate the capacity of a boiler whose evaporative efficiency can not be determined by actual test. The amount of heat absorbing surface which a boiler contains is the most effective factor in determining its evaporation. Of course, the value of each square foot of heating surface varies with the amount of heat which is supplied to it from the furnace, which will depend upon its position with relation to the furnace, ordinary rates of combustion and fair grades of coal, the number of feet of heating surface necessary to produce a horse power in a boiler of ordinary construction ought to be approximately determinable, and the power of the boiler determined for ordinary conditions the effect of extraordinary conditions could be estimated.

### CHIPS AND BARK.

Be firm! one constant element in luck  
Is genuine, solid, old Teuonic pluck;  
See yon tall shaft; it felt the earthquake's thrill,  
Clung to its base, and greets the sunrise still.

Many good sawlogs have knots on them.

People like to travel in cheerful company.

A man is apt to run down when his affairs are wound up.

Cover a nail with soap and it will drive in hard wood easier.

A northern clime—an Arctic bear skinning up the North Pole.

Men seldom conceal their virtues, nor do their faults conceal them.

Creaking boots may be prevented by driving a peg into the sole.

Not to be out of fashion, the lawns now wear their summer hose.

The man that never committed a folly never appreciated wisdom.

The roots of a tree are of more consequence than its highest branches.

A busy baker may not be an idler, but it must be admitted that he is a loafer.

The only people who are discontented are those who are not doing their whole duty.

"Two heads are better than one." This was written before three-story bonnets came in fashion.

"Bring up the child in the way he should go," and then follow him and keep out of bad company.

The fact that there are two hemispheres goes to demonstrate that the shape of the earth is spherical.

"Did you put flowers on the old soldier's grave?"  
"No; I did better. I sent a barrel of flour to his poor widow."

Tom—"Have you asked Bessie yet?" Jack—"Yes."  
Tom—"What did she say?" Jack—"That she would take vanilla."

Teacher—"In the sentence, 'The sick boy loves his medicine,' what part of speech is loves?" Johnny—"It's a lie, mum."

"Only a belt manufacturer and worth over a million? How did he ever make it?" "By attending strictly to his own business."

How nice it is to hear the raftsmen shouting in the early morning and the cook's grumbling in dulcet tones because the pots are black.

The horseshoe crab chews its food with its legs, which is a very curious thing even for a crab to do, while the oyster feeds with his beard.

The saw-mill proprietor desirous of an appropriate coat of-arms should paint on the panels of his carriage the latin motto, "*Vidi*," which by interpretation is "I saw."

Granpa—Yes, its a good thing for a boy to travel, Freddy; it develops him. If he has anything in him, travel will bring it out.

Freddy (who is precocious)—Yes I discovered that when I was crossing the Atlantic.

"Hello!" said the Pine Log to the Hickory Log.  
"How have you been?"

"Pretty well, thanks. What has become of your brother?"

"Oh, he has gone into a large importing house in New York. Where is yours?"

"Doing picket duty on a back yard fence."

The more the girls pine for some young man, the more spruce they become.—*Timberman*.—Yes, and did yew ever notice how lovers slab-ber over each other's dimensions, and how re-joist they are when cypressing each other's hands, and how soon life becomes a chestnut to them if they carry the j-oak so far as to get spliced? By gum, it's all queerious, every way, is life from a lumbering point of view.—*Exchange*

The small boy's view of it: "Papa," inquired the editor's only son, "what do you call your office?" "Well," was the reply, "the world calls an editor's office the sanctum sanctorum, but I don't." "Then, I guess," and the boy was thoughtful for a moment, "that mamma's office is a spanktum spanktorum, isn't it?"

### THEY LIKED JAM.

Citizens of St. Paul and Minneapolis were treated a few nights ago to a novel sight to them. A jam of twenty million feet of logs was formed at Taylor's Falls on the St. Croix River, having been carried into the narrows by a sudden rise of the water. The railroad companies, learned of the attraction and advertised it. Excursions were formed which took the curious to the scene of the log pile for the small sum of \$1.75.

### THINGS QUEER AND CURIOUS.

The \$10,000 painting of Christopher Columbus, executed by the famous Moro in 1540, and purchased in London by Charles F. Gunther, will be displayed at the World's Columbian Exhibition, Chicago.

A million men standing close together, each not occupying more than four square feet, could be placed on a patch but little more than a third of a mile square. A square mill will accommodate 7,965,000 men.

Thunder was never heard more than fourteen miles from the flash of lightning. The report of artillery has reached much greater distances. The cannonading of the battle of Waterloo was heard at the town of Creil, in the north of France, about 115 miles from the field.

The period of a generation has been lengthened; it used to be thirty years and later increased to thirty four; now a scientist says, the average term of human life has increased to forty-two years, and the improvement has all been made during the last half century.

Very few people have any idea of the cost of some of the rare metals. For instance, vanadium cost about \$11,265 per lb.; zirconium, \$7,080 per lb.; and lithium, which is the lightest of metals, about \$6,880 per lb. Rhodium, which is extremely hard and brittle and is only fusible at a very high temperature, brings about \$2,260 per lb.; and iridium, the heaviest substance hitherto discovered, costs about \$1,070 per lb. It will therefor be seen that gold and silver are far from being the most precious metals as far as their market value is concerned.

The oak grows very slowly. It has been known at 100 years old to be only one foot in diameter. Until the age of 40 years it grows pretty fast, but after that its increase becomes less and less sensible. At 200 or 300 years old these trees are at their best. Vancouver, from observations on the growth of timber in Hampshire, arrived at the conclusion that the relative growth of wood in that country, taking the trees at 10 years' growth, and the oak as a standard is: oak 10, elm 16, ash 18, beech 20, white poplar 30. That is to say, in any given time, if the growth of oak be 1, the growth of white poplar will be 3.

One of the oldest wooden stairways that exist is the flight which leads up to the gallery of the Sainte Chapelle, in Paris, on the north side of the shrine, its companion on the southern side being a restoration. It was built during the first half of the thirteenth century, when Saint Louis erected the chapel, to contain the Crown of Thorns, now preserved at Notre Dame. It is very delicately carved, and is regarded as a masterpiece of the finest period of Gothic art. The stairs wind about a central newel and are supported on the outside by uprights which form an open-work sage.

Every one may not know that the Bank of England notes are made from new white linen cuttings—never from anything that has been worn. So carefully is the paper prepared, that even the number of dips into the pulp made by each workman is registered on a dial by machinery, and the sheets are counted and booked to each person whose hands they pass. They are made at Laverstroke on the River Whit, in Hampshire, by a family named Portal, descending from a French Huguenot refugee, and have been made by the same family for more than 150 years. They are printed within the building, there being an elaborate arrangement for making them so that each note of the same denomination shall differ in some particular from the other.

### STARTING A NEW SAWMILL.

Says a writer in the *Saw Mill Gazette*: "In starting a new sawmill, there are a number of things to be reckoned on. Are we limited in power? Then we shall have to bend all our other parts to fit our power. Are we limited as to the amount to be sawed? Then it will be useless to put up a larger mill than is needed. In any event, to have the mill go we must have a harmony of all the parts which may be named thus: the power, the speed, the feed, the number of teeth, the size and thickness of the saw, the kind of wood to be sawed, the number of men to run the mill, and the amount of logs."

## OTTAWA LETTER.

## Other Things Beside Scandals—The Biggest Saw Mill in the World—The Future of Lumber Heavy American Shipments.

[Regular Correspondence CANADA LUMBERMAN.]

The average reader, I fancy, cannot think of the capital of the Dominion except as the very hot-bed of scandals and speculations. These things in truth smell "higher to heaven," than, to use Senator Snowball's words, "the saw dust dump, right under Parliament House." Well we are certainly getting our share of the pestiferous things, and the worst of it is the end is not yet. But less even readers of THE LUMBERMAN should be carried off in the swim, and think of Ottawa only from this untoward side, let us hold up the other side of the shield and assure them that this is a community known for other and better things than political corruption.

## THE BIGGEST IN THE WORLD.

We can claim to have almost ready for operation the biggest saw mill, not only in the Dominion, but in America, and it is said, in the world. I refer of course to J. R. Booth's big mill, with its 13 band saws, which is now about ready for complete operation. With a capacity for 900,000 feet daily, or for a season of seven months 153,000,000 feet, visitors to the capital will find it a place worth visiting, a monument to hard, honest work by one of our best citizens. And they need not stop here. Ottawa is creditably known as the centre of lumbering operations for the Dominion. A visit to any of our larger mills—Bronson & Weston's; Buell, Orr, Hurdman & Co's., the Gilmour's, Perley & Pattee's and others will well repay the time and trouble.

## THE LUMBER OUTLOOK.

Our lumbermen are feeling hopeful of the future. General activity prevails around the Chaudiere, and the expectation is that an unusually large quantity will be cut in the bush for sawing here next summer. Preparations in this direction have commenced, several leading firms having already sent men up to their limits to cut roads and otherwise pave the way for extensive winter operations. Wages are not high, because of the season's trade having been slack, but they will improve as the season advances. While there will be little or no square timber taken out, the number of men who will be given employment logging will be twenty-five per cent in excess of those of last year. Three trains a day leave the Chaudiere yards at present, each train carrying upwards of 400,000 feet of lumber for various American points. The principal shippers in this case are Messrs. Booth, and Bronson & Weston. Some of the firms here cannot fill orders for want of dry stuff. Nearly all the immense quantities of dry stuff that were on the piling

grounds have been shipped. The demand for the coarser grades is only fair, but the best grades are constantly in demand.

Ottawa, Ont. Aug. 28th 1891.

## BRITISH COLUMBIA LETTER.

## Depression in the Lumber Trade—Mills Closed Down—Opinions of a Michigan Lumber King on Pacific Coast Trade—Visits of Wisconsin Lumbermen—News Notes.

[Regular correspondence CANADA LUMBERMAN.]

SINCE my last letter several mills have closed down for from 3 to 6 months on account of the depression in trade. This is principally caused by the Chillian troubles, but the Australian market has experienced a sudden drop in prices. The demand has decreased; the MacLaren-Ross Lumber Co. was the first to close down. They only cut the two cargoes *Jonisa Maita* and *Leonor*. This is a great disappointment to many, as this concern would have employed a great many hands in its works.

The province has been favored with a party of tourists from Minnesota and Iowa, among the number being several of the best known lumbermen in the Mississippi valley. When in Vancouver they visited a number of sawmills. In an interview Mr. Wm Carson of Eau Claire, one of the number, said, that he had been much pleased with a visit to the Hastings saw mill where he had seen larger logs than he had ever seen before. There was no doubt in his opinion western lumber would become more common on the eastern markets. It was estimated that the timber supply of the Mississippi valley would be exhausted in about eight years and he thought the Pacific coast timber would hardly compete with the white pine of Wisconsin and Iowa for fine work, but he admitted that he had not had much experience with the cedar of British Columbia or Puget Sound. There was no doubt but that the lumbermen of the east were turning their attention to the west and some of them would no doubt engage in the business in the west.

Mr. N. L. Slaght, one of Michigan's lumber kings, who last year came to British Columbia and invested extensively in timber claims, arrived in Vancouver a few days ago. His company had intended to erect extensive saw mills in this Province some time this year, but the dullness in the lumber market caused him to advise the suspension of building operations until 1892. He would go into the exporting of lumber from the beginning of operations. Mr. Slaght has been engaged in lumbering since a boy, and that is quite a long time ago, and consequently is conversant with the business in all its details. He holds some opinions on the lumber question which are slightly different from the practice of the mills of this coast. He would prefer to have all the

lumber, or the greater part of it, exported from the Province, cut up into small stuff and dressed before shipping. He argues that in this form it could be more conveniently stowed aboard ship, would sell more readily when it reaches the foreign market, and would yield a profit upon the extra labor done in this Province which now goes to the purchaser, who has the deals and fitches, after he receives them, sawn into smaller pieces and dressed before retailing. He would also advocate having the saw mill men engaged in exporting to unite, so that a system of grading could be adopted and joint action on certain matters affecting all. The lumber business of Michigan was not reduced to a solid paying basis till this was done. With such an association a salesman could be sent to each of the leading foreign markets, who would handle the produce of all the mills, thereby turning the profits of the middle men into the pockets of the producers. Mr. Slaght is accompanied by his daughter, who comes west on a pleasure trip.

J. Galbraith & Sons new sash and door factory in this city is ready for the machinery which is daily expected.

Bush fires have been raging for two weeks in several parts of this district, but very little merchantable timber has been touched.

The frame for the Canadian Pacific Lumber Co's. mill is well advanced. The Portable mill is still sawing for this and other buildings.

The Burnett Saw Mill Co. and others will send an exhibit to Toronto Exhibition this fall, which will certainly attract considerable attention.

Mr. C. M. Beecher of B. C. Mills T. & T. Co. has removed to Vancouver to take charge of Hastings saw mill, which also belongs to this Co. and Mr. John Hendry returns here from Vancouver, where he was living while managing the Hastings mill.

The *Lanarkshire* arrived last week and has discharged her rails for the tramway between here and Vancouver last night and will come here to discharge the pipes for our Water Works system. The demand for shipment of lumber to the northwest continues.

H. G. R.

New Westminster, B. C. August 22, 1891.

## FOR SALE - A RARE CHANCE.

A VERY desirable mill property in the town of Essex, Ont., known as the Hanlan Mills, for the manufacture of staves and lumber. The daily capacity of 20,000 feet of lumber and 34,000 staves. Twelve acres of land for mill yard, on which is located 4 charcoal kilns, 1 boarding house, two tenant houses, barns, sheds and other outbuildings, with an unlimited supply of pure well water; with or without horses, trucks, waggons, etc. Also six million feet of standing timber, one-half elm; balance oak, cottonwood, ash, maple and sycamore; from one to three miles from the mill; and other timber in easy reach can be bought. The mills are on the line of Michigan Central Railway, with two spurs running into the mill yard, and within fifteen miles from Detroit. Terms liberal. Good reasons given for selling. Write or call on the proprietor, T. H. DECEW, Essex, Ont.

## WANTED AND FOR SALE.

Advertisements will be inserted in this department at the rate of 15 cents per line each insertion. When four or more consecutive insertions are ordered a discount of 25 per cent. will be allowed. This notice shows the width of the line, and is set in Nonpareil type. Advertisements must be received not later than the 27th of each month to insure insertion in the following issue.

**TO LUMBERMEN**—For Sale—400 acres well timbered land, of which 350 acres never culled, being lots 23 and 24, concession 10, Sombr, County Lambton, 4 1/2 miles from Sydenham River, navigable for tugs; log house and stable. Address, WILLIAM SPAVEN, Hagersville, Ont.

**WANTED AT ONCE**—delivered at Toronto Junction, from \$5,000 to \$10,000 worth of lumber for building and manufacturing purposes for fully paid up stock in a flourishing manufacturing business, well established; a continuous supply of over 2,000,000 feet required annually. The Gurd Brandon Woodware Co., Limited, Toronto Junction, Ont.

**PARTNERSHIP WANTED** in Sawmill Sash and Door or Furniture Factory, or any other class of good wood working establishment. Advertiser will invest \$5,000 cash. Address, "PARTNER" care of CANADA LUMBERMAN.

## SAW AND SHINGLE MILL

**FOR SALE**—on the Manitoulin, near Little Current. A bargain. Address, W. L. H., CANADA LUMBERMAN.

**HARDWOOD** lumber, bought, sold or received on consignment, TUCKER DAVID, lumber commission merchant, 202 Eleventh Ave., N.Y.

## RAILS AND CARS FOR SALE.

Light Steel Rails for Tramways; good order. Cars for lumber, cheap.

JOHN I. GARTSHORE,

49 Front St. West, Toronto.

## WANTED—TO BUY.

**GOOD** Canadian Timber Limits and Georgian Bay saw logs. Address, BEN BIRDSALL, Whitney Building, Detroit, Mich.

**MORTGAGE SALE** of Desirable Sawmill Property and Timber Limits in the Township of Limerick, County of Hastings.

Under and by virtue of the power of sale contained in a certain mortgage, which will be produced at the time of sale, there will be offered for sale by Public Auction at the premises in the village of St. Ola, County of Hastings, on **Tuesday September 8th, 1891**, at 2 o'clock in the afternoon, the following sawmill property and timber limits in three parcels, namely:

**FIRST**—All those parcels of land consisting of lots 5, 6 and 7 on Edgar Avenue, in the village of St. Ola in the Township of Limerick, County of Hastings, according to C. F. Aylesworth's registered plan of part of St. Ola, and being subdivision of parts of lots 9 and 10 in the 1st Con. of Limerick.

**SECOND**—All the timber on about 800 acres of land being lots 4, 5, 6, 8 and others in the 7th Concession of Limerick aforesaid, consisting of ash, birch, bass, cedar, maple, hemlock, &c.

**THIRD**—1 complete saw rig, 1 circular saw and belting, 1 large driving belt.

The improvements on parcel 1 consist of frame sawmill, engine and boiler, and the property is on Beaver Creek and has a good mill pond for logs and is about 2 miles from Central Ont. Ry.

Ten per cent. of the purchase money to be paid down at time of sale and balance in one month thereafter for parcels 1 and 2 and cash for parcel 3.

For further particulars and conditions of sale apply to Messrs. R. M. Mowat & Co., Trenton; P. F. Clark, Esq., St. O's, or to

S. J. YOUNG,

Vendors' Solicitor, Trenton, Ont.

Aug. 5th, 1891.

## PLANING MILL FOR SALE.

A Planing Mill and Sash and Door Factory in running order and fully stocked with best machines. Land freehold. **GOOD LOCATION IN TORONTO. WILL BE SOLD AT A BARGAIN ON EASY TERMS.**

Apply to "Planing Mill"

Canada Lumberman.

## Peter Gerlach &amp; Co.

Manufacturers of

## ALLIGATOR CHISEL-BIT SAWS

The Champion Stave, Heading and Shingle Machines.

Ice Tools and Mill Supplies.

CLEVELAND, OHIO.

## GOOD BUSINESS CHANGE

A party having the disposal of about 50,000,000 feet of good standing White Pine under Government license, besides a vast quantity of standing Hemlock, Spruce, Birch, &c., in a most convenient part of the District of Muskoka, together with a good Mill, nearly new, containing the very best machinery, is anxious to meet with a purchaser or parties willing to form a joint stock company. The whole property will be put in at an extra good bargain, and employment arranged for practical men. Full particulars as to Limits, Mill and prices, map, &c., can be seen at the office of the "Canada Lumberman."

E. F. Ames &amp; Co.

Lumber Commission. Correspondence solicited from Canadian manufacturers.

Room 3, Lumber Exchange, Chicago, Ill.

*Repairing*  
*Promptly and*  
*Carefully*  
*Executed*

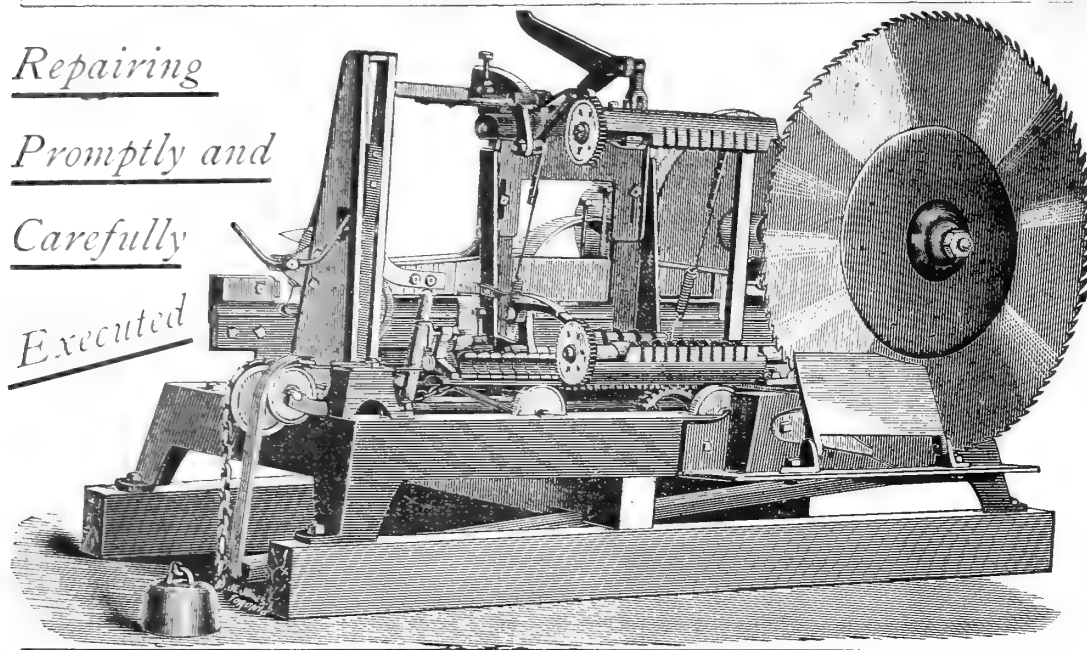

**B. R. MOWRY & SON**  
MANUFACTURERS OF

**Saw Mill**  
**and Shingle Mill**  
**Machinery.**

*Shingle Machinery a Specialty.*

**The "BOSS" SHINGLE MACHINE**

Manufactured by us is acknowledged by practical men to be the best machine in the market.

GRAVENHURST, ONT.

# The \*XXX\* Saw \*Gummer\* and \*Sharpener

**HAS NO RIVAL**

**For Variety, Capacity or Quality of Work.**

OR FOR

Simplicity,

Durability

Cheapness.

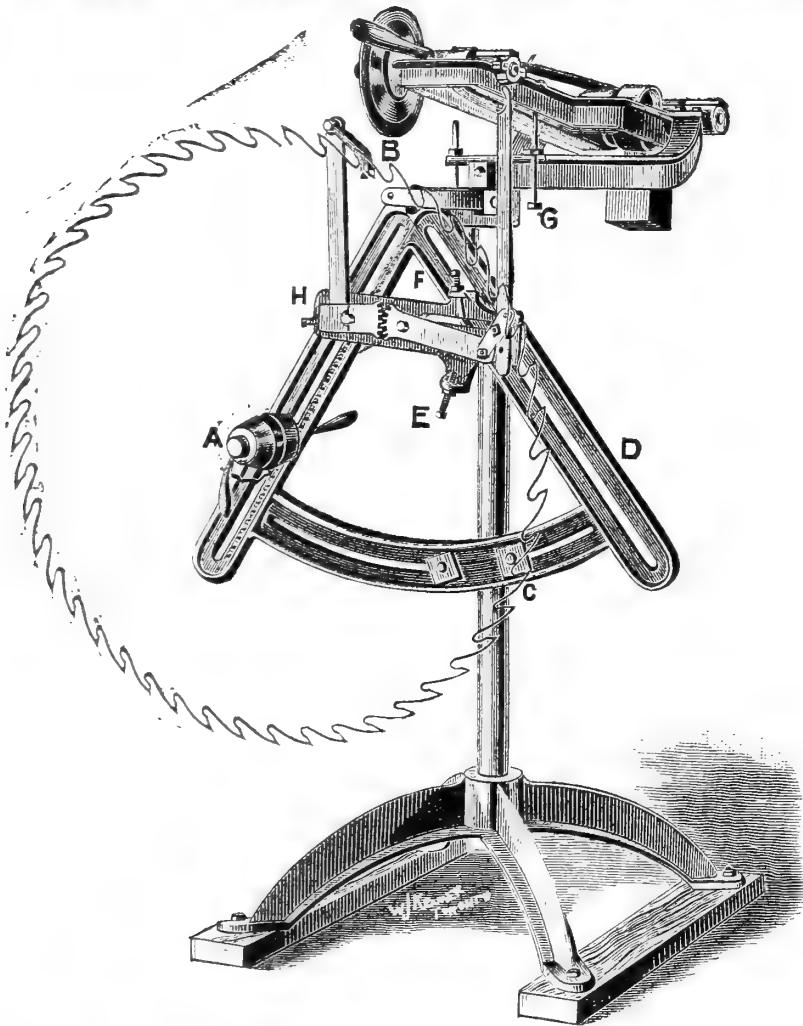

Will take saws from 6 inches to 6 feet diameter, sets the saw forward one tooth at a time automatically. Sharpens any saw (rip or cross-cut) perfectly. Giving the teeth any desired pitch or bevel, and making all the teeth exactly alike. Will sharpen 20 teeth in ordinary mill saw in One Minute, or 100 teeth in shingle saw in four or five minutes. The cut shows outline of mill saw 54 inch dia. Patent applied for.

MANUFACTURED ONLY BY

**F. J. DRAKE**

Belleville, Ontario.

# The Sturtevant System of Heating AND Ventilating

Applicable to all classes of Buildings.

**PROGRESSIVE LUMBER DRY-KILNS.**

**Steel Plate PLANING MILL Exhausters**

SEND FOR CATALOGUE.

**B. F. STURTEVANT CO., BOSTON, MASS., U. S.**

BRANCHES:

91 Liberty St., New York; 16 S. Canal St., Chicago 135 N. Third St., Philadelphia.

A. R. WILLIAMS, Soho Machine Works, Toronto, General Agent for the Dominion.

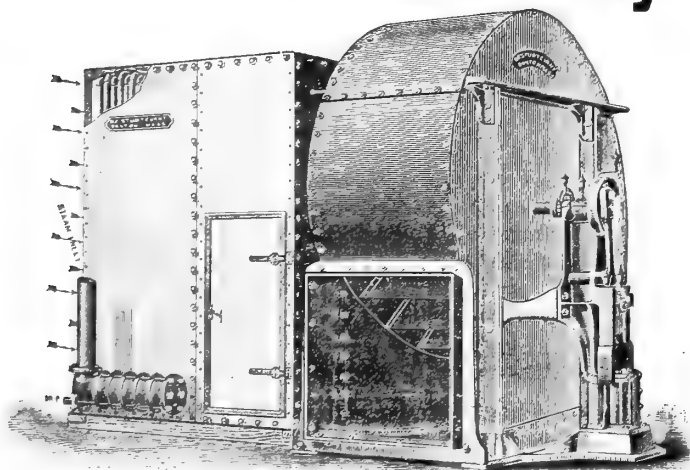

The Sturtevant Steam Heating and Drying Appartus.





# EXHIBITION



## MY WAREHOUSES

Will be thrown open to the Public from September 7th to 19th, when the following lists of

# Machines, Engines and Boilers

WILL BE ON VIEW,

H. W. PETRIE, 141-145 FRONT ST. W., TORONTO. TELEPHONE 2590.

### Wood-Working Machinery.

ONE new eclipse planer and matcher, Galt make.  
**C**HAMPION planer, matcher and moulder, McGregor, Gourley & Co. builders: nearly new.  
**N**O. 6 planer and matcher, Cowan & Co's build.  
**L**ITTLE giant planer, matcher and moulder Price, \$200.  
**N**EW poney planers and matchers, only \$175.  
**F**OUR 20-inch poney planers: Harper, Cant Bros., Waterous, and Ross make.  
**24** inch poney planer, Frank & Co's make.  
**N**O. 4 poney planer, McKechnie & Bertram's build.  
**24** inch poney planer, Ross' make, Buffalo.  
**24** inch wood-frame planer, Kennedy & Son's make.  
**24** inch wood-frame surface planer. Cheap.  
**24** inch surface planer, Rogers' make, Norwich, Conn.  
**21** inch wood-frame planer, Kennedy & Son's build.  
**22** inch surface planer—McKechnie & Bertram.  
**12** inch diagonal buzz planer, new; Galt make.  
**D**ANIEL'S planer, R. Ball & Co's make.  
**B**EADING and moulding attachment for planer, Ross make, Buffalo.  
**N**O. 0 four-side moulder, McGregor, Gourley, builders.  
**8** inch four-side moulder, Dundas build.  
**N**O. 1½ three-side moulder, McGregor, Gourley builders.  
**N**O. 2 three-sided moulding machine, Galt make.  
**T**HREE-SIDE moulder, Rogers' make, Connecticut.  
**O**NE-SIDE moulder, Dundas build.  
**N**O. 0 shaper, McGregor, Gourley, builders.  
**S**HAPERS No. 1 and 2, Galt make.  
**N**EW power morticer, Galt make, also several second hand.  
**8** BORING machines—by different makers.  
**R**ESAWING machines—I have two band resaws, one circular resaw, all Galt make.  
**T**ENONING machine—one each, Goldie & McCullough, McKechnie & Bertram, Ross & Cant Bros.' make.  
**T**WO broom handle lathes, with cutters and countershafts.  
**O**NE axe-handle and spoke lathe.  
**W**OOD turning lathes, several sizes, new and second hand.  
**I**MPROVED power rod feed machine, McGregor, Gourley, Galt, builders.  
**S**AND papers and knife grinders, several of each.  
**I**MPROVED saw arbors, all sizes, Galt make, large stock.  
**O**NE improved iron frame swing saw, new, Buffalo make.  
**N**ew 30-inch, also 36-inch, band saws, Galt make.  
**N**EW 25-inch band saw, Cant Bros. make, Galt.  
**H** SCROLL and jig saws, at various prices.  
**N**O. 1 universal saw bench, H. B. Smith, build.  
**C**OMBINATION saw bench, Haggis, builder, Uxbridge.  
**I**O WOOD frame saw benches at very low prices.  
**T**HREE blind slat tenoners, all Galt make.  
**D**ODGE wood split pulleys at manufacturer's price. Quick delivery.  
**F**OOT and hand mitering machines, latest designs.  
**F**OOT and hand wiring machine, Galt make.  
**O**NE set cheese box machines.

### Miscellaneous Machinery.

**T**WO sets match machines. Also set clothes' pin machinery.  
**2** DRY KILN outfits, also several fans by different makers.  
**F**ULL particulars of any machine in above list on application.  
**T**WO sets cracker or biscuit machines with fine assortment of dies.  
**R**UGER & CO., builders.  
**O**NE leather rolling machine.  
**O**NE corn husker, Sell's make.  
**S**EVERAL buhr stone chopping mills.  
**O**NE ditching machine.  
**O**NE clover huller and thresher.  
**O**NE bobbin winder, Georgetown make.  
**O**NE laundry hand shirt ironer.  
**O**NE power and two hand paint mills.  
**S**EVERAL wrought and cast iron tanks and kettles.  
**B**ONE mill for green bones. Capacity ½ lb. per minute.  
**O**NE lot canning factory tools, presses, solder moulds, etc., etc.  
**O**NE galvanic battery, (McIntosh) Chicago, Ill. make.  
**H**AND and power meat choppers, also sausage stuffers.  
**100** PRESS plates for cotton or woollen mill use.  
**O**NE soda water fountain.  
**4** GREEN corn cutting machines.  
**2** SETS felling mill crank shafts with bearings and wheels.  
**P**ORTABLE forges: genuine Buffalo make.  
**O**NE Eureka smut machine and one purifier.  
**N**O. 2 Caligraph writing machine, also a World typewriter.  
**O**NE Ronald steam fire engine.  
**T**WO village hand fire engines.  
**O**NE Silsby steam fire engine.  
**T**WO Diamond mill stone dressers.  
**S**EVERAL large iron band wheels, turned and balanced.  
**O**NE 62 gallon Gasoline tank, Buffalo make.  
**O**NE sugar cane mill, Cincinnati build.  
**O**NE stump machine screw, also three cloth press screws complete.  
**N**EW hand corn shellers, only \$4 each.  
**C**ENTRIFUGAL pumps, all sizes.  
**C**OMplete steam heating plant for public or private building: a bargain.  
**O**NE clay crusher, Galt make.  
**O**NE shooting gallery tube.  
**B**OILER tube expanders and brushes; all sizes.  
**O**NE new 60-foot steam pleasure yacht at a bargain.  
**H**Ydraulic rams, several sizes, Seneca Falls build.  
**T**WO set plate bending rolls for boiler shop use.  
**O**NE derrick hay press, good order.  
**O**NE lot new bolting cloths, Goldie & McCulloch make.  
**O**NE lot wool'en machinery, cards, pickers, etc.  
**B**BRICK and tile machines, one of each.  
**T**WO fire proof safes, both good as new.

### Engines.

**225** HORSE power pair of engines, Northy & Co., builders.  
**75** HORSE power horizontal engines, Gartsshore build.  
**50** HORSE power horizontal engine, Goldie & McCulloch builders.  
**45** HORSE power horizontal engine, White-law, builder.  
**35** HORSE power horizontal engine, Northy make.  
**30** HORSE power horizontal engine, Northy & Co., builders.  
**25** HORSE power horizontal engine, American make.  
**25** HORSE power horizontal engine, Waterous Engine Company build.  
**25** HORSE power horizontal engine, McRae build.  
**20** HORSE power pair of twin engines, Montreal build.  
**20** HORSE power horizontal engines, F. G. Beckett & Co., build.  
**20** HORSE power rotary steam engine, Erie Iron Works make.  
**20** HORSE power horizontal engine, Kiley, builder.  
**18** HORSE power horizontal engine, George White builder.  
**16** HORSE power horizontal engine, American make.  
**16** HORSE power horizontal engine, Beckett make.  
**16** HORSE power horizontal engine, Tift & Sons, builders.  
**15** HORSE power horizontal engine, F. G. Beckett, builder.  
**15** HORSE power horizontal engine, Mount Forest make.  
**12** HORSE power horizontal engine in good order.  
**12** HORSE power horizontal engine, American make.  
**12** HORSE power horizontal engine, Kelley, maker, Hamilton.  
**10** HORSE power horizontal engine, F. G. Beckett builder.  
**10** HORSE power vertical engine, Swamscott Machine Co., make.  
**8** HORSE power vertical engine in good order.  
**6** TO 8 horse power twin engines, marine; American build.  
**6** TO 8 horse power new double cylinder engine; marine.  
**6** HORSE power automatic vertical engine; Berlin make.  
**6** HORSE power new champion engine, Waterous make.  
**6** HORSE power oscillating engine, Beckett build.  
**5** HORSE power upright engine, Cline make, Alliance, Ohio.  
**6** HORSE power horizontal engine, Reid & Barr, builders.  
**4** HORSE power horizontal engine; good order.  
**3** HORSE power horizontal boat engine, Meakins make.  
**3** HORSE power vertical marine engine, good as new.  
**3** HORSE power vertical yacht engine; new.  
**2½** HORSE power rotary engine; new.  
**2** HORSE power horizontal engine; refitted.  
**1½** HORSE power yacht engine, vertical; American build.  
**1** HORSE power horizontal engines; three in stock.  
**I-4** HORSE power horizontal engine, Yankee make.  
**T**WO rotary engines, Josiah Ross patent and make; send for cut.  
**I**RON and brass castings for model steam engines.  
**E**NGINE governors, all sizes and by different makers.  
**F**ULL particulars regarding any of above engines on application. I also have a large stock of portable and semi-portable engines and boilers.

### Boilers

**B**OILER 16 feet x 4½ inch, 50 tubes 3 inch.  
**B**OILER 13½ feet x 52 inch, 76 tubes 2½ inch.  
**T**WO boilers 15 ft. x 60 in., 84 tubes 3 inch.  
**B**OILER 14 ft. x 51 in., 62 tubes 3 inch.  
**B**OILER 14 ft. x 45 in., 52 tubes 3 inch.  
**B**OILER 14 ft. x 36 in., 28 tubes 3 inch.  
**B**OILER 13½ ft. by 36 in., 33 tubes 3 inch.  
**B**OILER 12 ft. 9 in. x 36 in., 33 tubes 3 inch.  
**B**OILER 11½ ft. x 3 ft. 3½ tubes 3 inch.  
**B**OILER 11 ft. 6 in. x 30 in., 33 tubes 2½ inch.  
**B**OILER 11 ft. x 48 in., 55 tubes 3 inch.  
**B**OILER 11 ft. x 40 in., 34 tubes 3 inch.  
**B**OILER 10½ ft. x 40 in., 33 tubes 3 inch.  
**P**AIR of boilers each 10 ft. 4 in. x 26 in., 11 tubes 3 inch in each.  
**B**OILER 10 ft. x 44 in., 50 tubes 3 inch.  
**B**OILER 8 ft. 10 in. x 30 in., 31 tubes 2 inch.  
**B**OILER 8 ft. 3 in. x 25 in., 16 tubes 3 inch.  
**B**OILER 8 ft. x 35 in., 28 tubes 3 inch.  
**B**OILER 7 ft. x 25 in., 18 tubes 2½ inch.  
**B**OILER 6 ft. x 30 in., 20 tubes 3 inch.  
**B**OILER 6 ft. x 22 in., 9 tubes 3 inch.  
**B**OILER 57 in. x 30 in., 17 tubes 2½ inch.  
**U**PRIGHT boiler 7 ft. 4 in. x 36 in., 64 tubes.  
**U**PRIGHT boiler 65 in. x 24 in., 21 tubes 3 inch.  
**U**PRIGHT boiler 4 ft. 10 in. x 30 in., 40 tubes, 2 inch.  
**U**PRIGHT boiler 42 in. x 30 in., 37 tubes 2 inch.  
**U**PRIGHT boiler 33 in. x 12 in., 4 tubes 2 inch.  
**U**PRIGHT boiler 30 in. x 13 in., 19 tubes 1½ inch.  
**P**ORTABLE fire box boiler 16½ ft. x 54 in., 55 tubes 3½ and 4 inch.  
**P**ORTABLE fire box boiler 12 ft. x 3 ft., 29 tubes 3 inch.  
**P**ORTABLE fire box boiler 11 ft. x 45 in., 28 tubes 2½ inch.  
**P**ORTABLE fire box boiler 10½ ft. x 25 in., 13 tubes 3 inch.  
**P**ORTABLE fire box boiler 10 ft. x 3 ft., 35 tubes 2 inch.  
**P**ORTABLE fire box boiler 8½ ft. x 33 in., 36 tubes 2 inch.  
**F**OR full particulars and prices of the above boilers, apply to H. W. Petrie, 141 and 145 Front Street West.

Remember The Address.

## H. W. Petrie

TORONTO, ONT.

Two Minutes Walk From  
Union Station.

Cant Dogs, Peavies,  
Skidding Tongs,  
Pike Poles, Coldshuts,  
\* Lumber Bob Sleighs. \*

# J. Muckleston & Co.

Kingston, Ont.

Manufacturers of RED TOP LINE

## LUMBERMEN'S \* TOOLS.

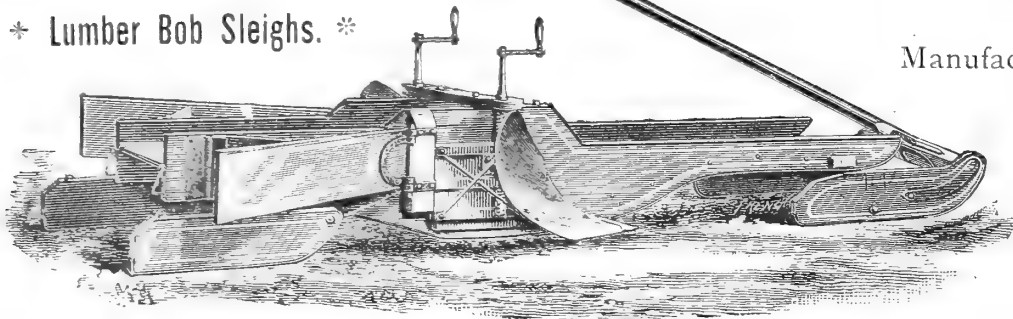

And Sole Licencees for the Manufacture in the Dominion of

## BRAZEL'S PAT. SNOW AND SIDEWALK PLOWS.

### DODGE PATENT

# Wood \* Split \* Pulleys.

We guarantee 30 to 60 per cent. more Power with same belt.

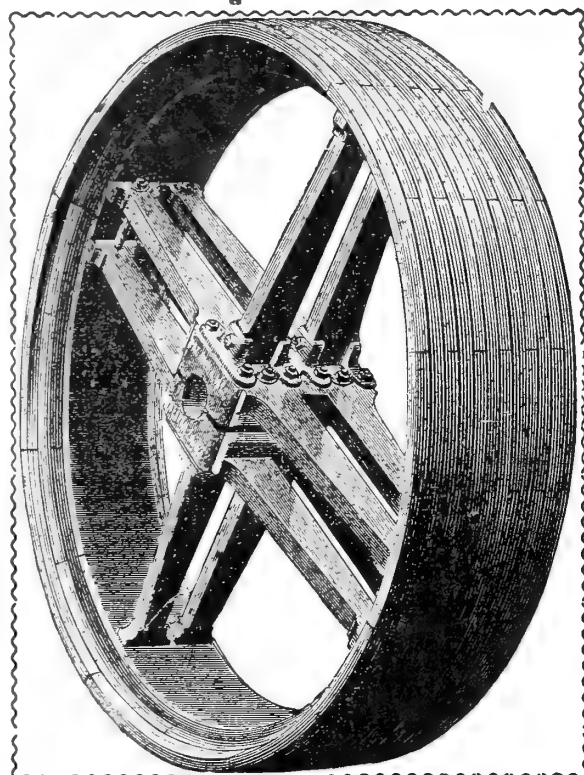

Every Pulley guaranteed strong enough for Heaviest Mill Work.

All Sizes in Stock. Send for Catalogue.

## DODGE WOOD SPLIT PULLEY CO.

83 King St. West, Toronto.

## ROCHESTER BROS. A. T. ANDERSON & CO.,

Commission Agents.

FACTORS FOR

### ELECTRICAL AND GENERAL MACHINERY.

Complete installations of team and Hydraulic Power, Electric Light and Power Plants, Wiring and Construction for Arc and Incandescent lighting. Agents for the celebrated "C. & C." Electric Motors.

75 Adelaide Street East, Toronto, Ont., Canada.

Estimates furnished and every information cheerfully given to intending purchasers. N. B.—Only first-class work on which a full guarantee will be given.

Limits bought and sold on commission. Limits travelled and carefully prepared estimates given. Some first-class berths on the north shore of Lake Huron and on the Upper Ottawa now in our hands for sale. Communications confidential. References given.

36 ROCHESTER ST., OTTAWA.

### Investment Bonds.

## THE DOMINION SAFE DEPOSIT WAREHOUSING & LOAN CO., LTD.

Head Office—The Canadian Bank of Commerce Building, King St. W., Toronto.

CAPITAL, ONE MILLION DOLLARS.

#### DIRECTORS.

W. D. Matthews, Esq., President.	Henry W. Darling, Esq., Vice-Pres.
John I. Davidson, Esq.	S. F. McKinnon, Esq.
H. W. Nelson, Esq.	J. P. Clark, Esq.
M. C. Cameron, Esq.	Robert Kilgour, Esq.
Thomas McCracken, Esq.	Robert Davies, Esq.
Aaron Ross, Esq.	Eugene O'Keefe, Esq.

This Company is now issuing \$100, \$200, \$300, \$400 and \$500 investments in bonds, payable in five, ten and fifteen years from date of issue, with participation in profits, affording all the advantages of compound interest accumulations on small sums of money. These bonds are the obligations of this Company and are specially protected by a sinking fund, invested in first-class real estate mortgages. They are plain definite contracts, subject to no contingencies whatever, are non-forfeitable after one annual payment, with values definitely stated thereon. For a small outlay they secure a fixed and generous return.

To bondholders who complete their contracts the Company guarantee compound interest at the rate of Four Per Cent. Per Annum.

The Company is prepared to receive applications from reliable agents at all points where it is not already represented.

The Safe Deposit Vaults of the company cannot be surpassed for absolute security. Call and examine or write for circular **WM. KERR, Manager**

### WILLIAM FOSTER

Lumber & Commission Merchant

Receiver and forwarder of

LUMBER, LATH & SHINGLES

Correspondence Solicited.

OWEN SOUND, ONT.

### Muskoka and Georgian Bay

Navigation Company.

#### Muskoka Division.

For all ports upon Lake Muskoka, Rosseau and Joseph, close connections are made daily at Muskoka Wharf with mail and express trains of G.T.R. from Toronto and Hamilton as under.

On Mondays, Wednesdays and Fridays at 7.15 a.m., the Muskoka leaves for Rosseau and intermediate places, and at 1.45 p.m., the "Nipissing" and "Kenozha" leave for all points on the three lakes.

On Tuesdays, Thursdays and Saturdays the "Muskoka" leaves at 7.15 a.m. for Port Cockburn and intermediate places, and at 2.45 p.m., the "Nipissing" and "Kenozha" leave for all points on the three lakes.

#### Georgian Bay Division.

The Str. "Manitou" leaves Parry Sound daily at 7 a.m., calling at Midland on Tuesdays and Fridays and at Penetanguishene on Mondays, Wednesdays, Thursdays and Saturdays. Returning she leaves Midland for Parry Sound on arrival of mail train at 1.42 p.m., on Tuesdays and Fridays, and Penetanguishene for Parry Sound on arrival of mail train at 12.45 p.m., on Mondays, Wednesdays, Thursdays and Saturdays.

The "Manitou" is the only daily boat to Parry Sound and the only boat running the famous South Channel among the islands where the best of fishing is to be had.

#### Magnetawan Division.

The "Wenonah" leaves Burk's Falls daily at 7 a.m. for Magnetawan, Abmie Harbor and intermediate ports, returning arrives at Burk's Falls at about 5 p.m.

#### Good Fishing—Safe Boating and Bathing.

Full information from any G.T.P. agent. Send for folders with map and full information as to rates, &c.

J. S. Playfair, A. P. Cockburn, President, Toronto, Gen. Mgr. Gravenhurst, J. A. Link, Sec.-Treas., Gravenhurst.

For information respecting the Georgian Bay Division apply to J. Wilkinson, 1 urser "Manitou," Penetanguishene P.O.



### J. D. SHIER,

Manufacturer of

Lumber, Lath and Shingles

BRACEBRIDGE, ONT.

ELECTRIC LIGHT PLANTS

# THOMSON-HOUSTON AND THOMSON SYSTEMS.

FOR MILLS AND FACTORIES.

THE ROYAL ELECTRIC CO. ADDRESS 58 WELLINGTON ST. MONTREAL, QUE.

**A. M. DODGE & CO.**

MANUFACTURERS of and Wholesale dealers in all kinds of Lumber, Lath and Shingles. Tonawanda, N. Y.

**COWPER & GREGORY.**

RECEIVERS and Forwarders of Lumber, Lath, Shingles, &c. Unexcelled facilities for shipping by canal or rail. Tonawanda, N. Y.

**CHEESMAN DODGE**

TIMBER and Lumber Merchants. Ship and Boat stock, Railroad Ties, &c. Office, 16 West Seneca Street, Buffalo.

**EMMET FLEMING**

INSPECTOR and Commission dealer in Lumber. Office, 251 Louisiana Street, Buffalo, N. Y.

**LAYCOCK LUMBER CO.**

MANUFACTURERS of Pine, Hemlock and Oak Timber up to 85 feet in length. Saw Mills: Ackley, Pa., Black Rock, N. Y., Gravenhurst, Ont. Office, corner Main and Seneca Sts, Buffalo, N. Y.

**J. & T. CHARLTON**

WHOLESALE dealers in Masts and Spars, Canada Round Pine, &c. Tonawanda, N. Y.

**WILLARD W. BROWN.**

202 Main Street, Buffalo, handles all kinds of Hard Woods.

**A. P. & W. E. KELLEY CO.**

WHOLESALE Lumber dealers. Yards at Tonawanda and Chicago. Correspondence invited.

**C. P. HAZARD.**

WHOLESALE dealer in Lumber, Shingles, Lath and Fence Posts. Correspondence invited from the Canadian trade. No 92 River Street, Buffalo, N. Y.

**L. A. KELSEY LUMBER CO., (Ltd.)**

MANUFACTURERS and dealers in Hardwood Lumber of all kinds. Describe stock and write for prices. Office Tonawanda, N. Y.

**BOVEE & HOWDEN**

MANUFACTURERS and Wholesale dealers in Hard and Soft Wood Lumber. Holders of Canadian stocks are invited to write for quotations. Offices at Tonawanda and Le Roy, N. Y.

**THE TONAWANDA LUMBER CO.**

MILLS at East Tawas, Mich.; office 106 Main Street, opposite N. Y. C. and H. R. R. R. Station, North Tonawanda, N. Y.



**LUMBER**

**TRUCK \* WHEELS.**

\*\*\*\*\*

**The Montreal \***

**\* Car Wheel Co.**

MANUFACTURERS OF

**CHARCOAL IRON CHILLED**

**RAILROAD WHEELS**

Offices: New York Life Insurance Building, Montreal.

Works: Lachine, Quebec.

\*\*\*\*\*

WE make a Specialty of Wheels suitable for the requirements of Lumbermen and Street Car Service, and can supply them Bored, Finished and Balanced.

CORRESPONDENCE SOLICITED

**J. J. TURNER,**

**Sail, Tent and Awning Maker.**

251 GEORGE AND 154 KING STREETS, PETERBOROUGH.

Canoe, Yacht and Boat Sails made to order. Perfect Fits guaranteed.

Every description of Lumbermen's Supplies and Waterproof Clothing.

**THE MONARCH BOILER AND HERCULES ENGINE.**

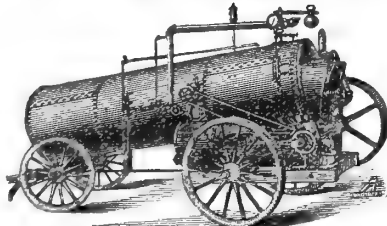

Portable from 6 to 70 horse power. Surpass portable steam power heretofore produced for strength, durability, compactness, and the ease with which they can be moved.

The 70 horse power can be taken over the roughest roads, or into the forest, and set up as easily and quickly as an ordinary 20 horse power portable engine, and as firm as a brick-set stationary engine. Engines and boilers of every size and description. Rotary Saw Mills, Shingle and Lath machines, Law Grinders, Planers, etc. Mill machinery and supplies of every description. Every boiler insured against explosion by the Boiler Insurance & Inspection Co. of Canada. Write for circulars.

A. ROBB & SONS, Amherst Foundry and Amherst, N.S. Machine works.

ESTABLISHED OVER 40 YEARS.

**PORTER, ROBERTSON & CO.**

STOCKS  
STRIPS  
SIDINGS  
BILLSTUFF

WHOLESALE

**LUMBER**

DEALERS

HARDWOODS  
HEMLOCK  
SHINGLES  
LATH, ETC

Millichamp's Buildings,

35 \* Adelaide \* Street \* East,  
TORONTO.

YARD: NORTHERN DOCK, FOOT OF BATHURST STREET.



ARE THE ONLY SPLIT GRIP PULLEYS & CUT OFF COUPLINGS MADE. GIVE EVERY SATISFACTION AS DRIVERS OR DRIVEN PULLEYS. FULLY GUARANTEED.

**WATEROUS ENGINE WORKS CO.**  
BRANTFORD, CANADA

**NAPANEE CEMENT WORKS**

— MANUFACTURERS OF —

**Hydraulic Cement**

PARTICULARLY adapted for Dams, Smoke Stacks, Foundations, Culverts, Cisterns, Cellars, etc.

ENDORSED BY LEADING RAILWAYS AND CONTRACTORS.

**ROACH \* LIME,**

For Building, Plastering, Gas Purifying, Paper Making, &c.

**THE RATHBUN COMP'Y,**  
DESERONTO, ONT.,

MANUFACTURERS OF

**\*TERRA COTTA\* FIRE-PROOFING\***

For Use in Old and New Buildings.

Endorsed by Leading Architects. Absolutely Fire-proof. About as Cheap as

Wood or Brick. Weight One-Third that of Brick. Does not

Crack on application of Heat or Water.

Deadens Noise. Gives Warmth in Winter; Coolness in Summer.

**Galt \* Machine \* Knife \* Works.**



**MACHINE KNIVES**

OF EVERY DESCRIPTION FOR

Planing, Moulding & Stave Cutting.

SEND FOR PRICE LIST

PETER HAY, . . . GALT, ONT.

HERBERT G. ROSS.

Box 273.

REGINALD C. BLAKER.

**H. G. ROSS & CO.**

Real Estate, Fire and Life Insurance, Shipping and General Commission Agents.

Timber Limits and Farming Lands a Specialty.

A.B.C. Code, Cable address, "Ross."

**NEW WESTMINSTER.**

**B. C.**

CORRESPONDENCE SOLICITED.



Waterous is the name we wish you to remember when requiring Sawmill or other Machinery.

**HEAVY SAWMILL  
MACHINERY.**

**PORTABLE  
SAWMILLS.**

## **The Industrial, 1891.**

Proprietors of Sawmills, users of machinery and the public generally will find much to interest them in our exhibit this year.

**CITY, TOWN AND VILLAGE** authorities should appoint a committee to examine carefully the No. 4 Steam Fire Engine built for the enterprising town of Sault Ste. Marie, which will be shown in operation. Also, Ariel Truck and Fire Department Supplies.

Waterous Engine Works Co., Brantford, Can.

If unable to call on us  
write for new Circulars  
stating your present requirements.

**STEAM FIRE ENGINES  
HOSE TRUCKS, CARTS, &c.**

**WOOD WORKING MACHINERY  
CRIP PULLEYS.**

Waterous is the name we wish you to remember when requiring Sawmill or other Machinery.

C. C. CLEVELAND. G. F. CLEVELAND.

**J. L. GOODHUE & CO.,**  
MANUFACTURERS OF  
**Leather Belting**  
AND  
**Lace Leather.**  
DANVILLE - - QUEBEC.

THIS SPACE FOR SALE.

RAILROAD, BANK & OFFICE

**DESKS**

TEES & CO.,  
300 ST. JAMES STREET, MONTREAL.

**STORAGE OF LUMBER.**  
We are prepared to receive any quantity of Lumber for storage. Freight and money will be advanced on same. Also, Warehouse Receipts issued, which can be hypothecated to banks and others. Storage charges easy. For further particulars apply to  
**W. LEAK & CO.**  
Lumber, Coal and Wood.  
DUNDAS STREET, - - TORONTO.

**GOODDAY, BENSON & CO.**  
QUEBEC, P. Q.  
**General Lumber & Timber Merchants.**

Correspondence is solicited from parties having choice stocks of Hardwood and Pine to offer, either in the log or in sawn lumber.

**JOHN BERTRAM & SONS,**  
CANADA • TOOL • WORKS  
DUNDAS, ONTARIO.  
MANUFACTURERS OF  
**WOOD-WORKING MACHINERY**  
MACHINE TOOLS, ETC.  
Write for Prices and Catalogues

THIS SPACE FOR SALE.

**GEO. CORMACK**  
Wholesale and Retail Dealer in  
*All kinds of LUMBER.*  
Lumber Shipped to all parts by Rail or Vessel.  
WHITBY, - - ONTARIO

**Toronto**  
**Lithographing Co.**  
LITHOGRAPHERS &  
TORONTO. ENGRAVERS.

THOS. WHALEY, President. W. E. HUTCHINSON, Sec.-Treas.

**The Whaley Lumber Co.**  
OF HUNTSVILLE, ONT. (LIMITED)  
Manufacturers of  
**White Pine Lumber, Bill Stuff, Lath and Shingles**  
ALSO HARDWOOD LUMBER.  
All orders promptly attended to. First-class facilities for shipping.  
CORRESPONDENCE SOLICITED.

**Peter Gerlach & Co.**  
Manufacturer of  
  
THE ALLIGATOR CHISEL-BIT SAW.  
**ALLIGATOR CHISEL-BIT SAWS**  
The Champion Stave, Heading and Shingle Machines.  
Ice Tools and Mill Supplies.  
CLEVELAND, - OHIO.  
**J. D. SHIER,**  
Manufacturer of  
**Lumber, Lath and Shingles**  
BRACEBRIDGE, ONT.



**Investment Bonds.**  
**THE DOMINION SAFE DEPOSIT WAREHOUSING & LOAN CO., LTD.**  
Head Office—The Canadian Bank of Commerce Building, King St. W., Toronto.  
**CAPITAL, ONE MILLION DOLLARS.**  
**DIRECTORS.**  
W. D. Matthews, Esq., President. Henry W. Darling, Esq., Vice-Pres.  
John I. Davidson, Esq. S. F. McKinnon, Esq. G. B. Smith, Esq. M.P.P.  
H. W. Nelson, Esq. J. P. Clark, Esq. J. H. Starr, Esq.  
M. C. Cameron, Esq. Robert Kilgour, Esq. Alexander Nairn, Esq.  
Thomas McCracken, Esq. Robert Davies, Esq. Eugene O'Keefe, Esq.  
Aaron Ross, Esq.  
This Company is now issuing \$100 \$200 \$300, \$400 and \$500 investments in bonds, payable in five, ten and fifteen years from date of issue, with participation in profits, affording all the advantages of compound interest accumulations on small sums of money. These bonds are the obligations of this Company and are specially protected by a sinking fund, invested in first-class real estate mortgages. They are plain definite contracts, subject to no contingencies whatever, are non-forfeitable after one annual payment, with values definitely stated thereon. For a small outlay they secure a fixed and generous return.  
To bondholders who complete their contracts the Company guarantee compound interest at the rate of Four Per Cent. Per Annum.  
The Company is prepared to receive applications from reliable agents at all points where it is not already represented.  
The **Safe Deposit Vaults** of the company cannot be surpassed for absolute security. Call and examine or write for circular **WM. KERR, Manager**

**THE RATHBUN COMPANY,**  
DESERONTO, - - ONTARIO,  
MANUFACTURERS OF  
**Doors, Sash, Blinds, Stairs**  
AND ALL KINDS OF WOODEN HOUSE FINISHING MATERIALS.  
**CEDAR OIL FOR PURGING BOILERS.**  
CORRESPONDENCE SOLICITED

**The American Lumber Yard**  
**HAMBURG, GERMANY,**  
Offers the best facilities for Yarding and Selling all kinds of  
**American Wood Goods**  
Address :  
ROSENBACHER & CO., CARL GARTNER, Agent.  
BANKERS, Hamburg. Hamburg.

TAPER TOOTH.

E. R. Burns

LANCE TOOTH.



Saw Co. TORONTO.



TELEPHONE 5120.

CIRCULAR AND

Long Saws

Works at Parkdale.

WICKES BROS., Saginaw, Mich.

MANUFACTURERS OF

GANGS, ENGINES AND BOILERS.

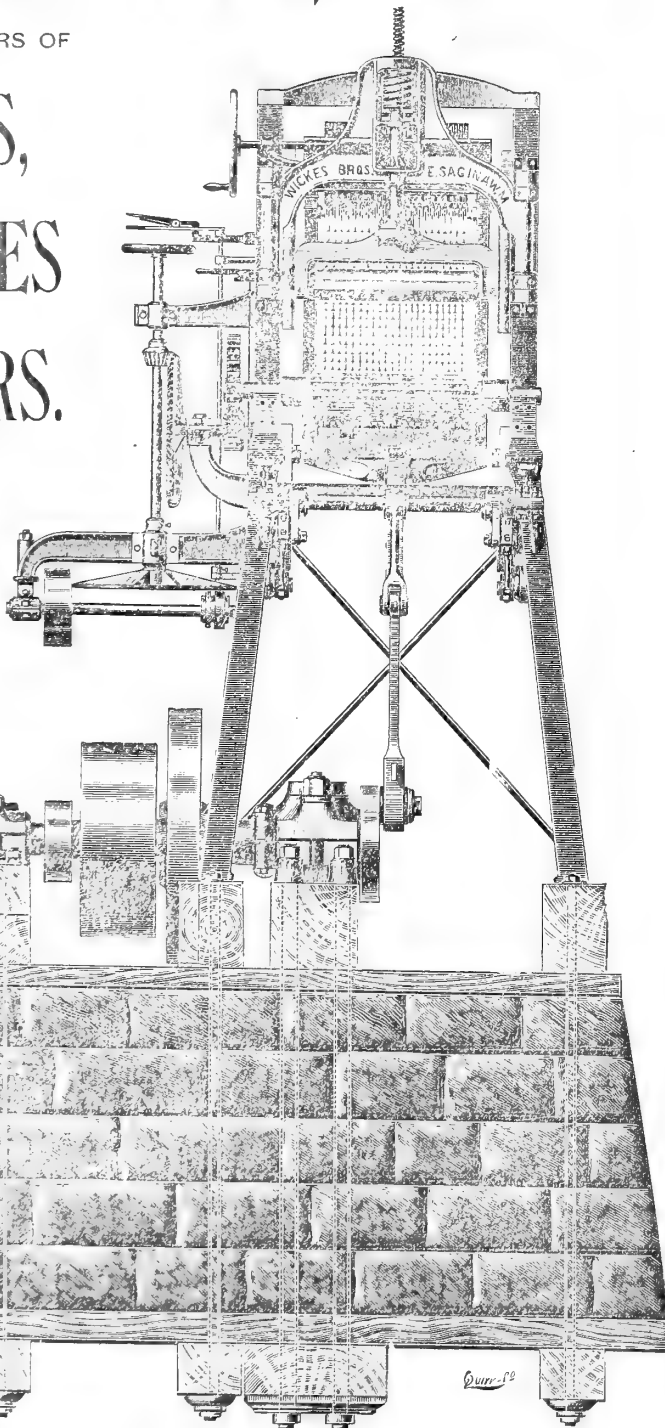

The accompanying cut represents our new No. 3 Complete Iron Frame Gang Mill especially designed to meet the demand for a smaller type of mill. The strongest and most durable for high speed and thin saws. Write for further particulars.

Southern Agents, McARDLE & SINCLAIR, 50 & 52 Barronne St New Orleans, La.



SCRIBNER'S LUMBER AND LOG BOOK

Over One Million Sold.

MOST complete book of its kind ever published. Gives measurement of all kinds of Lumber, Logs, Planks, Scantling; cubical contents of square and round Timber; hints to lumber dealers; wood measure; speed of circular saws; care of saws; cord-wood tables; felling trees; growth of trees; land measure; wages, rent, board, interest, stave and heading bolts, etc. Standard book throughout the United States and Canada. Get the new illustrated edition of 1882. Ask your book-seller for it. Send post-paid for 35 cents.

GEO. W. FISHER, Box 238, Rochester, N. Y.

or A. G. MORTIMER, Toronto, Ontario.

TORONTO AGENCY OF

The Rathbun Co.

ARE OPEN TO PURCHASE

OAK, ASH, BIRCH, BASSWOOD AND GOOD PINE LUMBER

CEDAR AND PINE SHINGLES

Manufacturers having such for sale are invited to communicate with

T. W. WALKER, Agent

TORONTO

Office, Cor. Spadina Ave. & Front St.

ROCHESTER BROS.

Commission Agents.

Limits bought and sold on commission. Limits travelled and carefully prepared estimates given. Some first-class berths on the north shore of Lake Huron and on the Upper Ottawa now in our hands for sale. Communications confidential. References given.

36 ROCHESTER ST., OTTAWA.

A. T. ANDERSON & CO.,

CONTRACTORS FOR

ELECTRICAL AND GENERAL MACHINERY.

Complete installations of team and Hydraulic Power, Electric Light and Power Plants, Wiring and Construction for Arc and Incandescent Lighting. Agents for the celebrated "C. & C." Electric Motors.

75 Adelaide Street East, Toronto, Ont., Canada.

Estimates furnished and every information cheerfully given to intending purchasers. N. B.—Only first-class work on which a full guarantee will be given.

The Casselman Lumber Co.

CASSELMAN, ONT. Successors to FLATT & BRADLEY.

ESPECIAL GOOD FACILITIES FOR SHIPPING. HEMLOCK BILL STUFF OF EXCELLENT QUALITY.

ALSO MANUFACTURERS OF

PINE, SPRUCE, ASH, MAPLE AND OTHER HARDWOODS.

CORRESPONDENCE SOLICITED.

J. W. MAITLAND H. RIXON

J. G. AINSLIE W. STODART

Maitland, Rixon & Co.,

Owen Sound, Ont.

Saw Millers and Lumber Dealers

All kinds of Building Material kept in stock.

WE MAKE A SPECIALTY OF

LONG BILL STUFF IN ROCK ELM, PINE, CEDAR AND HEMLOCK

QUOTATIONS FURNISHED ON APPLICATION.

ADVERTISING

—IN—

THE CANADA LUMBERMAN

PAYS.

WRITE FOR RATES.



# THE CANADA LUMBERMAN.

VOLUME XII }  
NUMBER 10 }

TORONTO, ONT., OCTOBER, 1891.

TERMS: \$1.00 PER YEAR.  
SINGLE COPIES, 10 CENTS.

## LARGE TIMBER DESTRUCTION.

A MELANCHOLY sight in British Columbia and Washington is the enormous areas of forests through which fires have swept, leaving only blackened trunks. The forests of the Pacific slope are going a good deal like the bison of the plains. The people of this continent do not realize how many hundreds of thousands of dollars' worth of fine timber in that region is being annually destroyed. Through the Rocky Mountains along the Canadian Pacific Railroad one may travel for many miles and see hardly a bit of live timber, though the blackened trunks standing quite thickly together show that a few years ago the mountain sides were covered with spruces and hemlocks. A good deal of this devastation is wrought by hunters and locomotives, and the fires are accidental. In some parts of British Columbia, however, and in Washington the farmers are destroying a great deal of timber to clear land for agricultural purposes.

In the last days of July the atmosphere was beautifully clear, and for many miles the grand pyramids of Mount Baker and Mount Ranier could be seen, rearing their splendid cones high above all their surroundings, and showing their great sides covered with the snow that never seems to melt. Three days later a gentleman was within ten miles of Mount Baker, and he could not distinguish the grand mountain for the air was oppressively heavy with smoke. It did not take long to find out who started these fires. Here and there in the timber through which the train sped across Washington were little clearings, and farmers and their men could be seen felling trees and setting fire to the branches. It is the only way they have of removing timber, so that they may plough the land. They have no means of getting the wood to market, and the only thing they can do is to reduce the enormous growth to ashes and then pull out the stump, and thus add a little to their tillable area. They are fortunate men if they are able to clear more than an acre or two a year, for the work is enormous; but when an acre is finally freed of its heavy burden of timber it is found to be magnificent farming land.

But it seems a terrible waste to see these mighty forests reduced to nothing but smoke and ashes. Now and then one sees a more cheerful picture in these woods. At a side track he will find a large number of flat cars, loaded with big logs all ready to be taken to a sawmill. This is a lumber camp, and through the timber may be seen the little pine or canvas huts of the lumbermen, who are felling the trees and trimming the logs ready for shipment. Then again the traveller sees a sawmill, where lumber is being turned out in great quantities; but probably fifteen times as much timber is destroyed without profit to a living soul as is now being utilized in the forests of British Columbia and Washington. It is a terrible waste, but there is no present prospect that it will be stopped.

## SPONTANEOUS FIRES.

THE number of fires due to what is commonly called spontaneous combustion is probably much greater than is generally supposed. An innumerable number of substances are liable to undergo the process, and as a good deal of ignorance appears to exist in regard to the connections which are necessary for its development, it seems worth while to offer a few hints on the subject. Many organic, and some inorganic, substances, when exposed to the air in a moist state, absorb oxygen and so develop heat. The rusting of iron, the decay of leaves, and the putrefaction of nitrogenous matters are examples of this kind of action. In ordinary cases the mass of oxidizing matter is small, and the heat conse-

quently, being speedily dissipated, has but little intensity, or is even quite insensible to ordinary tests.

Heat is, however, always produced, and when, as in a hot-bed the mass is considerable, the tendency becomes notable. When large masses are concerned with sufficient supply of air, but without the possibility of free ventilation, the heat sometimes becomes so intense as to produce actual combustion. In a few well known cases this takes place in contact with water. Thus; cotton closely packed in a moist place, on board ship or in warehouses, has been known to become ignited, and serious fires have arisen from this cause. Hay stacked when moist always becomes greatly heated, and not unfrequently gets thoroughly charred, or even bursts into flames, and the same phenomenon has been observed in barns and granaries. Many fires in country places are, no doubt, due to this cause, and probably some that are ascribed to arson.

Coal, which contains much pyrites, absorbs oxygen and becomes heated rapidly when moist, and although proof is commonly impossible, it is generally believed that fires, particularly at sea, have often originated in this way. But the greatest danger arises when cotton, hemp, jute, flax, or even saw-dust or charcoal, saturated with oil or turpentine, is stored in masses. Under such conditions, the supply of air being limited, spontaneous combustion is sometimes matters of certainty. We do not wish to exaggerate the danger of spontaneous combustion. Most fires are, probably, due to gross carelessness, particularly in the matter of lucifer matches, which are often used with amazing recklessness, or to the too close proximity of wood-work to stoves and open fires. But it seems certain that risk of the kind we have indicated is constantly incurred in ignorance, and we hold it to be a public duty to point out to all, but particularly to warehousemen and ship-owners, the character and causes of the danger which besets them.

## ORDER AND SYSTEM.

THE common theory is that if one man who has a mill of a certain capacity and furnished with a set of the latest and most improved machinery, and is able to run it successfully and profitably, there is no good reason why another having equally as good a plant and possessing the same advantages for business, should not be equally successful. Now, theoretically, this may be the case; but practically it is not always so. That there is a cause for this no one will deny, but to arrive at just that cause is not always so easy a matter, as there are so many small matters to be taken into consideration that combine to bring about this effect, but all may be summed up under the head of order and system.

In the successful mill there will always be found a certain system which is strictly carried out in every department from the time the lumber is received in the rough state until the finished product is ready to be delivered. Everything is so arranged that there is no unnecessary handling, each man has a certain part of the work to perform and he is expected to perform that work in a proper and judicious manner. Every part of the outfit is kept in the best working order so that each machine is capable at all times of turning out the greatest possible amount of good work in a given time.

In such mills breakdowns and expensive repairs are seldom met with and the saving in repairs by close attention at the proper time is one important item that goes far to help increase the profits at the end of the year. It is not so much in the actual cost of the repairs as it is in the loss of the work that the machine would perform while those repairs are being made.

Cutting up the lumber preparatory to being worked

is another important item in the management. The careful and experienced man at the saw will scan every board and cut it up in such a manner as to get the greatest amount of clear stuff, worth from two to three dollars per thousand more than it would be were it cut up haphazard, as is the case in many mills. A wide board, for instance, may be knotty on one side while the other may be clear and there is no economy, in cutting up such stuff into second class flooring when by a little management a strip six inches wide that is perfectly clear may be had and go into a lot of first class stuff. Again, the careful sawyer will so adjust his machine that each strip for matching will be just the proper width and no more. It is no uncommon thing in measuring such strips as they come from the edging saw to find them anywhere from one-eighth to one-fourth of an inch wider than necessary in order to match full, and while one-eighth or even one-quarter of an inch may seem to be a small matter to talk about, yet if only one-eighth is wasted on a strip six inches wide it means one hundred eighths in a hundred strips which amounts to little more than two whole strips six inches wide and when the number of such strips that go to make up a day's matching with a modern fast feed planer is taken into consideration, the loss is no small item. While it may not be practical to rip up stuff so close that there will be no waste, yet much of the waste in cutting up such strips for matching might be avoided by having one experienced and careful man at the saw for this purpose.

The same rule that applies to the saw is equally applicable to every other machine in the mill. It is true that in some of the smaller mills it may not be possible to give each man a machine and keep him constantly employed upon it; but in mills of larger capacity where all the machinery is kept constantly in motion, it is not only practical, but necessary, in order to obtain the best results. The fact is, that when a man is kept constantly upon one machine and doing a certain class of work day after day he soon becomes familiar, not only with that class of work, but also becomes acquainted with all the peculiarities of the machine, and the necessary changes and adjustments will be made in less time than by one who is not, and the result is that he will get more and better work out of it in a given time.

It is a fact that almost every kind of mechanical work is fast running to specialties, and there is no reason why planing mills should not adopt the same system as far as possible. Experience among the different manufacturers has demonstrated the fact that there is less profit in working men upon the all around principle than there is in giving each man a particular machine and a certain part of the work and keeping him constantly employed on the specialty. Planing mills and other wood-working establishments which have adopted this plan and work upon a correct system with each man to his particular machine and class of work, are more successful than those who have no regular system but work their men upon the all around principle, one day upon the saw the next upon the planer, and so on. Order and system is one of the laws of God and without it no business can be successfully conducted.

## A POPULAR ROUTE.

The Manitoba-Pacific route of the Great Northern has opened up a new and picturesque route to Spokane, Washington. The route from St. Paul and Minneapolis runs via Neche, N.D., Winnipeg, Man., to Revelstoke, B.C., thence by steamer on the Columbia River to Little Dalles and then rail to Spokane.

## AUTOMATON MEN.

WHAT manager, superintendent or proprietor of a wood-working establishment who has not had in his employ, for a time at least, men who were mere automatons—men who appeared to have no more intelligence so far as to discern the difference between doing a certain kind of work the right way, or the wrong way, or if they knew did not care, than the machine which they attended? They performed their work in a mechanical manner. They would handle a board or plank and feed it through the planer or matcher, because they were told to do so by the "boss." They would hold such board or plank up to the guide of the rip saw, or shove it up to the cut-off saw, with about as much interest in their work, or evidence of a true purpose to secure the best results from their work, as the machines which worked up the lumber. A new idea or suggestion from anyone as to how a piece should be examined, studied and manipulated so that it might otherwise yield a larger profit to the proprietor would stagger such a man like a stroke of paralysis. His only ideas of the duties of his daily life were that they were of a mechanical nature. He worked, ate and slept as if he were a human machine. Originality, study, thought were entirely foreign to his nature.

If in a planing-mill where he attended a planer, the lumber to be surfaced only on one side, he never turned over the piece of lumber to examine it and to ascertain the best side to surface. Instead, he would pick it up and allow it to go through the machine, the same side up as that which he found it. It would be the same if a piece was to be surfaced and matched, or made into flooring or ceiling. He could not comprehend that there was a difference in the quality of the two sides of the piece of lumber, and quite as likely as not surfaced the poorest side. His dominant idea was that he was there in the same capacity as if he were feeding a sausage machine or emptying the grist into the hopper of a corn mill.

Every day that he worked he damaged lumber to the extent of more than two weeks of his wages. In a lot of lumber which you had bought as culls, some of it so graded on account of bad sawing, and being thick or thin in the middle or ends of the boards, what had been intended by the sawyer to be an inch board, by the saw "snaking" had become as one and a-half or two inches thick piece of lumber in places. While it was thus not an attractive looking piece, the quality, had it been sawed properly, would have placed it in one of the higher grades. The automaton has the planer set to surface seven-eighth inch thick, regardless of the thickness of the lumber. He places this thick and thin piece of lumber on the bed-plate of the planer, gawks around the mill, or outside, or watches a railway train pass by the mill, or gives more attention to somebody else's business than to his own. Meanwhile the planer draws in the piece of lumber until it gets to the thick part where the knives have to cut way an inch of solid wood without slacking the feed. The planer, which is not a heavy one, struggles and groans under the imposition of the task. Something must give way. Snap goes a belt, or it flies off the pulley, if nothing more serious occurs. Then follows delay in fixing or repairing and valuable time is lost, all through the stupidity of the automaton booby, who made pretense of attending the machine. In this instance the machine seems to have shown more intelligence than the man, for it would not submit to unfair treatment beyond a certain limit.

How much better for the interests of the proprietor of an establishment for the work required, is such a man than an ingeniously-contrived machine which would answer the same purpose? Some may say that this is overdrawn, but there are hundreds of just such men to-day who are at work in planing mills all over the country.

It is pleasing to know that we have another type of men entirely opposite to that of the automaton. It is the inquiring, investigating, studious, watchful man, who is always trying to do his work well, but better from time to time. He is always alert, vigilant. Nothing in his line of business escapes his notice. He is said to possess knowledge of an intuitive nature. We shall not discuss the metaphysical view of that question, more than to say that we have good grounds for believ-

ing that much of his discernment and clearness in his judgment resulted from his study in his special line of work.

## THE DISADVANTAGES OF INSUFFICIENT BELT SURFACE.

A FRIEND of the writer was talking with a belt manufacturer the other day, and in the course of conversation the belt man said, "I wish you would try some of this new belting of mine in some of your hard places where the belts must stand the hardest kind of strain and wear." "Well, I would if I had any such places: but I don't, and what is more I won't have, as long as I am a sane man."

On being asked to explain he spoke as follows: "I run belts wide enough so that there need be no undue strain on any of them, and I haven't got a double belt in my place." There was only one thing for the belt manufacturer to say, and he said it. "If everyone would plan shafting and machinery in the same manner, there would be no trouble from belting," and he struck the key-note of successful belt running. What my friend meant by saying he had no hard places in his establishment, was that he always used belts wide enough to do the work without straining them like fiddle-strings, as we often see.

To a certain extent this is impossible, as the makers of machinery have not yet reached that point in their education which teaches them to give the proper amount of belt surface, for the work in hand, without straining the belt until it is ashamed of itself. Lathes and other machinery as well will be found with a three-inch belt where a four-inch is required to do the work nicely without undue strain. When full capacity is expected of any machine the belt suffers, as it must be laced up another notch or two, without improving the belt in the least.

The harm does not stop here, but it continues until the machinery suffers as well, and many cut boxes and bearings worn out of true, can testify. This strain is not evenly distributed, and the lathes have got out of line as a result of this barbarous treatment.

We see belts listed as having such a carrying capacity, and invariably we find that the double belt is rated as having double the carrying capacity, yet it is to be doubted when we think of it thoroughly. What increases the power of the double belt over the single? There is no increase of surface, and is not surface the main factor in the question of the power of a belt?

The only increase of power due to the double belt is in the ability to stand a greater strain on the bearings, shafting and all other interested parts. It is an undoubted fact that a double belt will stand a much greater strain than a single, but it is hardly good practice to strain bearings in order to save the room occupied by the additional width, that a single belt would necessitate, and the cost of the wider pulleys.

It is just as cheap to buy a 10-inch single belt as a five-inch double, and the machinery fares a great deal better; the cost of the wider pulley is hardly to be considered at all, as the saving in cost of maintenance of shafting and the attendant parts. The rating of double belts as twice the carrying or transmitting capacity of single belts seems absurd when it is considered in detail. With nothing to increase the capacity except the ability to stand greater tension, this claim should be dropped as soon as possible as a relic of the past. Whether the theory of air pressure on the outside of the belt be abandoned or not (and in the face of the success of the wire link belt it looks a little doubtful if it can be maintained) the question of slack belts is the same. For if the frictional theory be the accepted one, the increase of surface on the pulley will certainly add to the driving power.

The advent of the perforated belt was by many deemed as proof conclusive, that the "air" theory was doomed to retirement, but to the writer it has appeared as an additional argument in its favor. For assuming the theory just mentioned the presence of air under the belt would prevent the atmospheric pressure from acting to its full extent, the imprisoned air being a sort of back pressure which lessens the efficiency of any means of transmission or power.

There are few appliances that are so abused as the

one under consideration, namely, the old and tried friend of all shops, the belt. We find it stretched out of all resemblance to its former self, laced in a slipshod manner and half the lace holes torn out, making a fine place for the belt to catch against the fingers of the shifter and finally tear out and come down on somebody's head. When we go into a shop of this kind and see the belts as just described, we are pretty sure to find a shop where the time of attending to the shafting, hot bearings and the attendant ills, would make a big item in the shop accounts, if it was counted in the list of running expenses. But this kind of a shop never keeps much account anyhow, and guesses at the charges to be made for work, with the result of either losing money or driving custom elsewhere.

It is not idle capital to have belts running slack and doing less work than they possibly might be made to do, for it is much better to have the capital invested in this way than to have delays, cut boxes and the annoyance that follows in the wake of all unsatisfactory machinery and parts, in the whole establishment. It is a pleasure to see a nicely running belt, to go in a nice engine room and see the great driving belt that is running the whole of a great plant and doing it without apparent effort, the belt being so loose as to almost touch the lower part where the sag of the upper half comes. This is a sure sign that the journals are running cool and everything is going along as nicely as possible. That is perhaps a rash statement, for there are exceptions and a cool journal may not follow, as there may be some cause that is foreign to the belt question; the bearings may not be large enough for the work and heat from that reason even without any belt on the engine.

In one case to the writer's knowledge a new engine was installed, and run hot from the first; all kinds of lubricants were tried without making any improvement in the bearings being cool, and finally the makers had to increase the size of the journals to secure the desired end. This is a case where the belt has no bearing on the subject whatever and is an exception to the above statement.

Designers of machinery are too apt to slight the bearings, or else are not versed in the practical side of the question, for we often find machinery with bearings so small that it is impossible to keep them from heating and cutting. These cases must not be attributed to the belting, though the practice of tight belts, strained to their utmost, is responsible for additional trouble.

In this as in nearly all other branches of the shop or factory management, it is well to beware of the "tinker," for he is on hand here as elsewhere and is just as destructive. The care of the belting should be in responsible hands, and the increased efficiency and lack of trouble will more than repay the expense.

## SENSIBLE TALK.

LUMBERMEN, read your lumber trade newspaper very closely. In the hurry and midst of business do not throw it aside, to be forgotten and perhaps finally used for waste paper. After the day's work, when the evening lamp is lighted in the study and the good wife supervising the clearing away of the supper table, draw your easy chair near the lamp—light the evening pipe—put on your spectacles and go through your lumber trade paper from the title page to the last column of the advertising pages. You may, if you choose, give but a cursory glance to the editorials, but subject the correspondence and price-lists to your closet scrutiny. The notes of new enterprises, and new incorporations may offer many timely and valuable suggestions, and the review of the market is always worthy of consideration and reflection. Above all don't slight the column of advertised "wants." These are always newsy, and indicate the drift of current trade. Advertisements of labor-saving machines generally suggest ideas of practical economy. In the resting intervals, between suns, is the time to con the columns of the trade paper—to digest the information it contains, and then to sleep on it.

Pay a reasonable price for an economical boiler, and you have made a first-rate business investment.

### THE DANGER OF CIRCULAR SAWS.

A DELIVERANCE BY THE INSPECTOR OF FACTORIES

THE Inspector of factories for Ontario in his report recently published deals at some length with the danger attending the use of circular saws. One-sixth of the accidents which occur are due, he says, to these dangerous tools. The subject is necessarily one of practical importance to lumbermen and saw mill men. The report says:—

"Saws in general are known as upright, band and circular. To these latter I more particularly refer. They have various names according to the work they are required to perform, or on the manner they are set up and operating in their frames, such as shingle, veneer or section, butting, edging, resaw, stave, equalizing, swing, railroad, angle, concave, cylindrical, grooving and others. These saws are supposed to be made of the best crucible or finest silver steel, and to be carefully and uniformly tempered throughout, requiring great skill and watchfulness on the part of the temperer. Great care is also required in hammering out these saws, as often the process forces the strain to one part, causing a slight bulge which may crack when some unusual strain is put upon the saw. The crack relieves the strain caused by the bulge, and on boring a small hole at the terminus of the fracture it will go no farther, and the saw, I have been informed by the maker of them, is safer than before the fracture.

"Shingle saws vary in diameter from 30 to 36 inches; are rather thin for their work, one would judge from their appearance, being about one-eighth of an inch in thickness, supported at the back by an iron flange to which the saw is made fast by proper screws. This flange will extend to within six or eight inches of the saw's circumference. These saws occasionally break as one did in Ottawa in October, the flying piece striking the workman near by in the side, causing his death 90 minutes later. Veneer saws are necessarily thin in order not to waste the valuable wood being cut into veneer. They are made in sections, fastened as a circumference to a steel blade or disc. Butting saws are in use in various works to square off the ends of lumber in saw mills and for cutting off butts of smaller sticks in other industries. Most of these saws I look upon as being very dangerous, as the saw overhangs the frame so that persons may accidentally walk or stumble against it.

"Edging saws are chiefly used in mills for cutting off the bark edge from the boards. I do not know that there is any special danger from these, except it be that in many saw mills the saw for cutting the logs and the butting and edging saws with their tables or frames are rather crowded together, so that the workers are sometimes jostled by the lumber being handled, and thereby thrown against the saw. In a resaw machine I do not consider there is any special danger. They are common in planing mills and in other wood-working industries, and no accidents have yet been reported to me from this machine. The stave or cylindrical saw is a tube of steel about two feet in diameter, about 36 inches in length, with the teeth on the outer end, and is used for cutting heavy staves such as are used for oil or liquor barrels. The cylinder is set up in a frame and is used horizontally, near the floor. The special danger of this saw is the liability of a person to run against it. It would be difficult to prevent this by a guard, as the wood can only be fed in from the end exposed. Equalizing saws are two cross-cut saws on the same mandril, at the extreme ends; each saw overhangs the frame in which it is set and projects a few inches in front of it. They are used for cutting off the staves or stave bolts to an equal length. In stave works they are set the length of the stave—32 inches apart; they are also used in factories making wagon or carriage wheels for equalizing the spokes. In some of these equalizing machines the wood to be cut is fed into the saws by being placed on a table swinging from above, and in others the feed tables rest on pivots below. I consider these saws to be very dangerous, and not easily guarded, but those with the table resting on pivots may be guarded with respect to the top and front of the table by putting a suitable box across the table, covering the saw, allowing room at the end for the clearance

of pieces of wood cut off. But this does not prevent risk of injury from the lower part of the saws, which in this arrangement of feed table, it seems hard to guard against. On the other hand those equalizing saw machines, so arranged so to feed from the table swinging from above, cannot be guarded in the same way as the other, as the box covering the saws would be in the way of the feed table swinging through between the saws. So while the front and lower part of the saws in this arrangement can be guarded, I do not feel satisfied that the top of the saws can be. At best those saws are dangerous—more than ordinarily so.

"Swing saws are those attached to the frame, which is usually swung from the above floor. There is more than ordinary danger from these. The operator has to pull the saw up to its work, overcoming the resistance of a counterbalance weight, which is attached to the swing frame, generally by a rope, but occasionally by a chain. Sometimes the chain gives way and allows the revolving saw to come forward with sufficient force to reach the operator, often causing serious injury. As a check to this there ought to be a frame built down from the floor above in such a position that its cross-piece will arrest the forward motion of the swinging frame at a point which would prevent the operator from being touched with the saw. There is difficulty in putting a guard over the saw itself of this machine, and many have them. As to rip saws, several practical men have informed me that all of this kind could have a wedge set on the table behind the saw to keep open the cut, so as not to bind the saw, which causes the saw to be thrown forward and frequently injuring the sawyer. This year in Ottawa one young man was reported to me as meeting his death from this cause; also other injuries more or less serious were reported. The railroad saw is for a similar purpose to the swing saw, but usually for lighter work. It is of quite different construction, the saw being set in a sliding frame within the table, and by pressure of the foot on a lever is moved up to its work. I can see no special danger in this machine more than appertains to all saws; in fact I think that there is less than any other I have noticed without guards. The angle saw I consider very dangerous to the attendant, nor do I know of any way by which it can be made less so. The device consists of two saws set at right angles to each other, with their teeth just escaping contact. The saws operate on the top of the log to be cut, one cutting down and one cutting in, sawing out a square stick. They are used chiefly in chair and handle work. Here about as many of the uses to which the saws are put all depends on the watchfulness of the attendant. Concave saws are used for various purposes, but there is no special danger from them, more than from a flat saw rigged up in the same way.

"Another dangerous use of the saw is the machine for making axe handles. In this machine the saw, a thick one about 12 inches in diameter, projects in front of the frame, about one half its diameter, and there is nothing to prevent the attendant or other person from coming in contact with it and receiving most serious injuries. This can be guarded, and I have asked to have it done wherever I have seen this machine in use.

The recommendation is made that wood-working fences be kept free from bits of stick and other refuse that may trip or cause a person to fall towards the saw. This in some instances is done; one case is cited where the Inspector had to walk altogether on sticks and refuse from the saw, and where the floor, it is behind, was two feet below the rubbish.

### TREES THAT STING.

THOUGH the tropical shrubs of Queensland are very luxuriant and beautiful, they are not without their dangerous drawbacks, for there is one plant growing among them that is really deadly in its effects—that is to say, deadly in the same way that one would apply that term to fire, for if a certain proportion of one's body be burned by the stinging tree death will be the result.

They are found of all sizes, from three inches up to fifteen and twenty feet. In the old ones the stem is whitish, and the red berries usually grow in a cluster at

the top. It emits a peculiar and disagreeable smell, but it is best known by the leaf, which is nearly round, with a point at the top, and jagged all around the edges like a nettle. All the leaves are large, even on small plants—sometimes larger than a saucer.

The effects of the sting are curious. It leaves no mark, but the pain is said to be maddening, and for months after a jab from one of its numerous "stingers" the part stung remains very tender; especially so, if the true in rainy weather, and when the parts stung have been accidentally damped, even if very slightly.

Hunters who have found themselves surrounded in small forests of "stinging trees" in the dusk of evening have been known to lie down and pass the night as comfortably as possible, fearing to make an effort to extricate themselves in the dim, uncertain light, lest they might get deeper into the besetting trouble.

"I have seen," said Shuman, "a man who would treat ordinary pain lightly roll on the ground in agony for hours after being stung, and have known a horse so completely mad, after getting into the thicket of these trees, that he rushed open-mouthed at everyone that approached him, and had to be shot to relieve his agony."

Dogs, when stung, will rush about, whining piteously, biting pieces of flesh from the affected parts.

The small "stinging trees," only a few inches high are even more dangerous than the large ones, being so small they are likely to brush one's ankles before they are seen.

One safeguard for the experienced hunter is the fact that they always grow in palm thickets, and no place else. The presence of palm trees is, therefore, sufficient to put the old settler on his guard.

### SOME STATISTICS OF STEAM.

ACCORDING to a recent estimate, four-fifths of the engines now working in the world have been constructed during the last twenty-five years. France owns 47,500 stationary engines, 7,000 locomotives and 1,850 steamboat engines. Germany has 10,000 locomotives of all kinds, 59,000 stationary engines and boilers and 1,700 ship and steamboat engines. Austria has 12,000 stationary engines and 2,800 locomotives. The force equivalent to the working power steam engines represent is: In the United States 7,500,000 horse-power; in England, 7,000,000 horse-power; in France 3,000,000 horse-power; in Austria 1,500,000 horse-power, and in Germany 4,500,000 horse-power. In these figures the motive power of locomotive engines is not included. Their number in all the world at the beginning of 1890 was 150,000, representing a total of between 5,000,000 and 7,000,000 horse-power, about 6,000,000 horse-power, which, added to the other powers enumerated above, gives a total of 49,000,000 horse-power for the world. A steam "horse-power" is equal to three actual horses' power, and a living horse's strength is equal to that of seven men. Therefore, the steam engines of the world represent, approximately, the working-power of 1,000,000,000 men, or more than double the working population of the world, the total population of which is usually estimated at 1,455,923,000 inhabitants. Steam has accordingly enabled men to treble his working power, making it possible for him to economize his physical strength while attending to his intellectual development.

### WHAT CUTTING A MAHOGANY TREE MEANS.

It is a full day's task for two men to fell a mahogany tree. On account of the spurs which project from the base of the trunk a scaffold has to be erected and the tree cut off above the spurs, leaving thus a stump of the very best wood from ten to fifteen feet high.

### THE TREE THAT FURNISHES REAL LACE.

A remarkable tree is found in Jamaica, the inner bark of which is composed of many layers of fibers that interlace it in all directions. Caps, ruffles, and even complete suits of lace are made from it. It bears washing from common soap, and when bleached in the sun acquires a degree of whiteness equal to the best artificial lace, with which this surprising natural product compares quite favorably as to beauty.



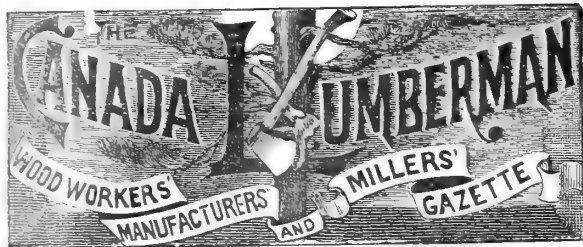

PUBLISHED ON THE 1ST EACH MONTH BY  
ARTHUR G. MORTIMER.

OFFICE:  
75 CANADA LIFE ASSURANCE BUILDING,  
TORONTO, ONTARIO.

TERMS OF SUBSCRIPTION:

One Copy one Year, in Advance, - - - - - \$1.00  
One Copy six months, in Advance, - - - - - 50

Foreign Subscriptions \$1.35 a Year.

Advertising Rates Furnished on Application.

THE CANADA LUMBERMAN is published in the interests of the lumber trade and of allied industries throughout the Dominion, being the only representative in Canada of this foremost branch of commerce of this country. It aims at giving full and timely information on all subjects touching these interests, discussing these topics editorially and inviting free discussion by others.

Special pains are taken to secure the latest and most trustworthy market quotations from various points throughout the world, so as to afford to the trade in Canada information upon which it can rely in its operations.

Special correspondents in localities of importance present an accurate report not only of prices and the condition of the market, but also of other matters specially interesting to our readers. But correspondence is not only welcome, but is invited from all who have any information to communicate or subjects to discuss relating to the trade or in any way effecting it. Even when we may not be able to agree with the writers, we will give them a fair opportunity for free discussion as the best means of eliciting the truth. Any items of interest are particularly requested, for even if not of great importance individually, they contribute to a fund of information from which general results are obtained.

Advertisers will receive careful attention and liberal treatment. We need not point out that for many the CANADA LUMBERMAN, with its special class of readers, is not only an exceptionally good medium for securing publicity but is indispensable for those who would bring themselves before the notice of that class. Special attention is directed to "WANTED" and "FOR SALE" advertisements, which will be inserted in a conspicuous position at the uniform price of 15 cents per line for each insertion. Announcements of this character will be subject to a discount of 25 per cent, if ordered for three successive issues or longer.

Subscribers will find the small amount they pay for the CANADA LUMBERMAN quite insignificant as compared with its value to them. There is not an individual in the trade or specially interested in it, who should not be on our list, thus obtaining the present benefit and aiding and encouraging us to render it even more complete.

"STRIKE BUT HEAR."

PROBABLY twelve years ago, we quote from memory, an important editorial from the pen of Dr. J. G. Holland, then editor, entitled "Strike but Hear," appeared in the pages of the *Century* magazine. It was written at the time of a great strike among the employees of a leading American railroad, and was characterized by that remarkable common sense that made the "Topics of the Time" of this journal so famous with all English reading people.

It was strike, but hear with the strike of that particular time. It has been strike, but hear with every strike before and since then, and it will be strike but hear with every strike until strikes shall be no more.

We remarked in these columns when commenting on the strike of the millmen of New Brunswick a few months ago, that strikes were seemingly the one barbarism of the nineteenth century. We were able to settle almost every other difficulty, national, international or individual by means of reasonable common sense, but a difference between capitalists and labor, two interests that above all others should be mutual, can only be settled apparently at the end of drawn swords.

Does a strike settle a strike? No; again quoting Dr. Holland's words it is strike—if one will—but hear. For months the carpenters of London, Eng. have been out on strike; what the issue will be is yet unsettled; but whatever the end; will the trouble be over? Even if the men obtained every inch asked, what will they have obtained? The primary object of this strike as every other is to secure certain supposed benefits usually in the direction of shorter hours for the same pay, or more pay for the hours established as the working

day. Both mean an increase in pay—a greater disbursement on the part of employer. What will have been the cost of securing this pay? We are not going into figures here; but will workmen out of their own individual experience tell us how many months they must needs work at the increased rate to recoup themselves for the loss of the months' wages while the strike was on? The matter has been figured out more than once, and the record is a terrible one.

But the disaster that follows a strike is not confined to the loss made during the days of idleness, which the workman hopes somehow to recover. With many it means putting the man and his family in a hole out of which they can neither pull themselves by the proverbial boot straps nor any other way. The store debts that have been incurred, the house rent accumulated, not to say anything of the poverty that has been endured by wife and children to keep the necessities down as close as possible, prove veritable millstones around the neck for all time to come. Let working men tell us if there is anything more difficult than to keep the house running along out of the week's wages, even though there be a dollar or two more than formerly, and at the same time pay off some old score that has been allowed to accumulate with grocer, with the doctor or elsewhere? Those who may have had the misfortune to have gotten behind at some period in their life know what this means.

But a strike extends far beyond the workingman in its injurious influence. Take the case of the railroad strike referred to by Dr. Holland. The loss to the public, who were not parties to, nor responsible for that strike in any way, has been carefully computed at tens of thousands of dollars, a loss which was an absolute loss, not possible in any way to retrieve. We have already referred to the strike of the carpenters of London, Eng. Its effect has been to stay building operations, curtail the sale of lumber, stop the buzz of the planing mill, cancel the contracts of plasterers, painters, and other trades dependent on the completion of the carpenters' work, reduce the sales of storekeeper, in short to paralyze the wheels of commerce in almost every direction. Let the strike be declared off to-day; would it be possible from the future to recover these losses of the past? Verily no: the old saw is emphatically true in this case, one cannot grind with the water that is past. What is lost, is lost. The wage bill per week of the millmen of Ottawa is \$25,000. Is it a trifling matter to the merchants of Ottawa, and in turn to the wholesalers who supply them, and to the bookkeepers, clerks and porters who are in the employ of the merchants, and dependent upon the success of the business for the permanency of their positions, that there should be a shrinkage in the trade of that one community to the extent of \$100,000 a month?

Dr. Holland was right; strike but hear—capitalist and laborer, both.

SOME ASPECTS OF THE OTTAWA STRIKE.

THE wages are not extravagant; the hours are long. The statement of the men is that the average wage is only \$1.08 per day. This is not however in keeping with the exact facts. The pay roll of Perly & Pattee shows 288 hands employed, at \$2,222 per week or an average of \$7.72 for each man. The wages range from \$6.91 per week for teamsters to \$15 and \$18 per week for millwrights. The average wage paid by Bronson & Weston is \$1.22 per day or \$7.33 per week. This it will be seen is a larger average than that claimed by the men. Then it is to be remembered that it is the inferior workman, who gets the small wage; the capable man is paid a more liberal figure. This is the case in every calling.

Eleven and three quarter hours is a long day; but the lumber trade differs from many other trades. The season is short, the mills only running on an average about five and a half months in the year. To cover the work required within this time, the day must necessarily be longer than the average working day. But, as a matter of fact, whilst a day from the time the men start to work until they close is eleven and three quarter hours, yet owing to the peculiar nature of the work,

causing a good deal of lost time each day from actual steady work, the working day does not count for more than ten hours.

In the case of one firm alone to meet the demands of the men would be equivalent to an increase of \$20,000 per year in wages. What would be the increase with one mill would apply proportionately to all others. Is the lumber trade in Canada in that shape that it will admit of any such an addition to the cost of cutting lumber? The history of the trade for a few years past gives a clear negative to the question. In any proposition for higher wages this matter must necessarily be considered.

The wailing boss and the professional labor agitator, as our Ottawa correspondent points out, have been a factor in the strike. We are firmly convinced that their influence is never in the direction of mending matters.

In the interests of commerce generally, and the lumber trade in particular, it is unfortunate that this strike should have taken place on the eve of the fall and winter trade. At this writing there does not seem to be much disposition on the part of either side to give way; yet we are hoping from correspondence in our possession, that if the men are left to themselves, and their passions and interests not excited by the professional agitator, that an amicable basis of settlement can be reached in time to prevent a loss of the remainder of the season's work.

GETTING NEARER THE SAW.

IN THE ELI page of this month's LUMBERMAN an extract is made from an article in a recent issue of the *Monetary Times* touching a statement made in an American lumber exchange that 100,000,000 feet of Canadian lumber have gone over the G.T.R. to the United States during the past few months. Rebutting this absurd statement still further, our city contemporary of later date adds: "Since our paragraph of last week on the lumber trade was written, there has come to our knowledge a specimen transaction which confirms the truth of what we then alleged. A builder on a large scale in Philadelphia, who has been in the habit of buying largely of lumber in American cities, visited Western Ontario a few days ago desiring to make purchases. His aim was, as he expressed it, "to get nearer the saw," this is, nearer the original source of supply, and that is the desire, we understand, of other builders in eastern American cities. The competition in various branches of the United States lumber trade has become so keen that the builder is anxious to do away as far as he can with intermediate profits, and so tries to avoid the middlemen. The result of this builder's visit is a purchase of sawn lumber at a Georgian Bay port for shipment eastward. It may be judged that trade direct from these mills is increasing and has as much to do with affecting American distributing points such as Tonawanda, Buffalo and Albany, as freight rates on the tariff, and probably more."

NOVA SCOTIA has taken a new departure in the construction of lumber carrying ships, by which a high rate of speed and sailing qualities and great carrying capacity are to be combined. The barquentine *Argentina*, built for the South American lumber trade, is the pioneer vessel in this recent addition to Canada's merchant marine. The *Argentina*, with a registered capacity of 583 tons, will carry 600,000 feet of lumber, while she can easily sail 12 knots an hour. She carries an immense deck load of lumber without any ballast whatever. She is expected to leave Montreal about 1st inst., for the River Platte, with a cargo of lumber, the first of the season from that port to that part of South America. Allowing 10 days to clear the river and gulf, she expects to make the balance of the run to Monte Video in 40 days, making the time for the whole run 50 days or thereabouts. The average time for an ordinary sailing vessel from Montreal to the River Platte, is about 70 days.

Wooden columns are far better than those made of iron. In case of fire the wood will require some time before it will be burned sufficiently to weaken it, but iron is easily heated, and in that condition will collapse immediately as soon as it comes in contact with water.

## EDITORIAL NOTES

THE monthly returns of the Board of Trade, of Toronto show exports in lumber for month of Aug. 1891 to be \$83,038 as against \$62,822 for the same month last year; an increase of \$20,216. The exports in the products of the forest in 1878 were \$19,511,575, and these had increased in 1890 to \$26,179,136 showing a growth in the lumber trade in Canada that is far from discouraging.

LEARY, the log rafter has made a reputation for himself in the success that attended his work in rafting large quantities of logs from New Brunswick to New York. But behold a greater than Leary has made himself known, and we are now told that Lock, Moore & Co., of Westlake, La., will try the experiment next season of rafting logs to England from Galveston. "The attempt" says a lumber contemporary "may seem too much of a risk for the amount of the prospective return. It has been demonstrated, however, that large rafts can be successfully towed on the ocean, but whether they can be made strong enough to withstand the hardships of such a long voyage, remains to be discovered. The greater the risk, the larger the profit, if the plunge is made on the right side."

THE collector of customs at New York recently wrote to the Treasury Department at Washington, in regard to the cancellation of export bonds under the departmental instructions, where the duty does not exceed \$100, upon presentation of a bill of lading without requiring the production of a foreign bill of lading. He pointed out the provisions of the recent reciprocity treaty with Spain, and the possibility that Canadian lumber exported from the United States may be entered in ports of the Spanish West India Islands as lumber of the United States. He enquired if, in the opinion of the department, the waiver of the requirement to procure foreign landing certificates would tend to a breach of comity towards a friendly power. Acting Secretary Spalding has replied that the department does not apprehend that the Government of Spain will construe as unfriendly the regulations referred to, as it applies equally to all exports made by the drawback of duties.

WORK on the Manchester ship canal in England is being pushed ahead with all energy. Its completion, which is expected next year, may have an important influence on the lumber trade of this continent. The calculation is, when the canal is opened, that by bringing timber ships straight to Manchester, instead of unloading them at Liverpool as much as seven shillings per ton will be saved in the carriage. The eastern portion of England forms the market for the Baltic white woods, and that of the west is supplied with American woods. Manchester being some thirty miles inland will most probably produce a redistribution of area and will send the American woods further east than they have hitherto gone, and this, if carried to the extent anticipated by the supporters of the canal, will effect in no slight degree the timber trade in America, Norway, and Sweden. The demand for the Baltic woods will decrease and that for American woods will increase to a corresponding extent simply because it will be possible at a cheaper rate to place the latter in the markets hitherto supplied with the former.

THE statement is made that cedar railway ties are being imported at Cleveland from Canada at a considerable undervaluation and an investigation has been ordered by the custom's authorities. In all lines of business conscience seems to come to a dead stop when the government of a country can be defrauded. Reference need not be made to instances as glaring in both kind and extent as the Tammany frauds of some years

since across the border, or our own revelations at Ottawa and Quebec just now. Perhaps to these, however, we must attribute the lesser peccadillos like cedar post undervaluations or the case of a woman from Windsor of a week ago, who was discovered in the act of bringing over from Detroit, carefully concealed beneath her petticoats, a bag containing a few brace of chickens and several dozen eggs, and who coolly admitted she had been doing this kind of thing for years and selling the stock to a local grocer. These are poor arguments for the removal of a custom's line between the two countries; the morals of both Yank and Canuck would at the same time be improved by the removal; and would not trade and commerce experience a relief by virtue of the freer breathing?

THE first fruits of Adam Brown's visit to the West Indies, so far as the lumber trade is concerned, are shown in a shipment of lumber a fortnight ago from Montreal to Kingston, Jamaica by E. H. Lemay of Montreal. Mr. Lemay says plainly that this shipment is the direct outcome of the Jamaica exhibition. It consists of 750,000 feet of lumber, and he was placed in direct communication with the firm to whom he made the sale through writing to Mr. Brown. If the first experiment is successful Mr. Lemay will continue to export to Jamaica. Other lumbermen will watch with interest the result of the Montreal experiment. Mr. Brown in his official report of his trip to Jamaica says, "a large and profitable trade can, if properly attended to, be done in lumber. Most of the supplies have hitherto been obtained from the United States, the large proportion of which is supplied to that country by Canada and culled there and sent to different tropical countries, Jamaica and other British West India Islands among the rest." White pine Mr. Brown says is in good demand. Likely difficulties in regard to freight rates were anticipated by Mr. Brown, but his efforts to have this question satisfactorily settled are hardly likely to prove futile. The experiment of Mr. Lemay will furnish practical information on the question.

MR. PHIPPS, forest commissioner for the Province, is untiring in his study and investigations on the subject of forestry. In his last report he refers to the indifference to the question in America in contrast with Europe. Here, on condition of the lumberman, paying the authorities a certain amount, he is allowed to cut the timber of the forest at his pleasure. In Europe, on the other hand, the wood buyer is carefully instructed as to what portion he may clear or thin, while, as soon as the ground is ready, it is again planted or the gaps filled. Two reasons for the American practice exist: (1) Farm land was needed. This reason is not now valid, as the pine land now left is very largely too poor for agriculture. (2) Chiefly the timber could be sold. "Matters have now come to pretty much the following condition: This generation, say after 30 years, will have timber enough, though it will have to use much wood hitherto thought unfit. After that there will be little good pine and not much good hardwood in our present forests. What is obtained will be brought from British Columbia and the forests of the southern states, while the generation following will exhaust these. Considering the well known benefit of keeping a large section of the country in forest—benefits which it is not the province of this paper to state—I would earnestly urge the people of America to consider how much more advantageous it would be at once and decidedly to say of certain large portions now in forest, "These shall not be cleared for settlement; "These shall be sacred to the tree." Once this determination is arrived at, the rest is easy. Nothing is more simple than to introduce and maintain a method of preservation, if populations demand it, and government fulfils its desires. It is often said, "We have a large proportion of forest land." But most of this is not good forests. Much has been run over by fire, much culled of every good stick by the lumbermen. But nearly all this might be renewed and made good, permanent forest, if the means were used."

OUR Ottawa correspondent reports a brief, but important interview with Mr. J. W. Todd, of Liverpool,

Eng., an extensive operator in Canadian lumber, who spent some time during the past month in the Ottawa district. Mr. Todd's talk has an amusing side, albeit in the interests of the Canadian lumbermen it is not desirable that the funny vogue should be continued. In all seriousness the CANADA LUMBERMAN and the newspaper press in general have been telling of the fast depleting stocks of dry lumber on the piling grounds of Ottawa and other lumber sections. Everybody in this country, who knows anything of lumber movements, was aware of this fact. These conditions have been growing worse each month until within the past few weeks it has not been possible in some cases to fill the orders that have come to hand. The members of the trade across the sea have read these statements, but have thought that Canadian lumbermen were playing at bulls and bears; at least to use Mr. Todd's words, "that the statements made respecting the shortness of lumber were greatly exaggerated." Our conservative and long headed Englishmen were not going to be caught by a caper of this kind, and consequently orders from England have been circumscribed. "Seeing is believing." Mr. Todd has been able to learn for himself the true condition of affairs. He now knows that the statements made on this side of the Atlantic have been moderate in tone and in no measure have they partaken of an exaggerated character. Stocks in the old country, Mr. Todd tells us, are low and getting lower, and putting these two conditions together, Canada has reason to expect a prosperous trade with England, after another season's cutting is put in our mills.

It reads like a joke to say that bread can be produced from sawdust, but propositions seemingly as absurd have before to-day turned out to be stern realities. The question is one in which lumbermen are interested, for they have the sawdust to sell and will hardly object to so large a market as one comprised of the bread-eaters of the whole civilized world. The problem is at present under investigation by the United States Department of Agriculture. This is the account given by a Washington correspondent: Scientists are of the opinion that no good reason exists why this thing should not be entirely practicable. It is a well known fact familiar to all that starch is a substance extremely nutritious; in fact, it is nearly all nutriment. Well, starch and sawdust are the same thing. Sawdust, which is "cellulose," is of precisely the same chemical composition as starch. The two are expressed by the same chemical formula  $C_6H_{10}O_5$ —that is, six parts of carbon, 10 of hydrogen and five parts of oxygen. These are the simple ingredients of either starch or sawdust. Scientific experimenters have been trying for a long time to find out a way to transform the one into the other. If they should succeed the discovery would be away ahead of the philosopher's stone in point of value. An inexhaustible source of food supply would at once be rendered available in the forests, in grass and even in straw and chaff. Hitherto chemistry has occupied itself almost wholly with taking things apart, in order to find out what they are made of; but now the science is directing its attention to putting elements together for the production of useful substances. Already it has succeeded in the artificial preparation of indigo, alizarin, and many other compounds. The aniline colors, obtained from coal tar and yet rivaling the most brilliant tints of the rainbow, are similarly produced. From coal tar in like manner are derived many valuable anti-fever medicines and soporifics. The prospects of this new science of putting elements together seem infinite, and the era of bliss may yet dawn which has been prophesied by the illustrious naturalist, Frederick Cohn, who says that all struggles for existence among men arising from want of food will be done away with when chemistry shall have learned to make starch from carbonic acid and water. Plants grow by doing just that, and it may, therefore, be said that farmers have been engaged since time immemorial in this very chemical industry. It would scarcely be surprising, then, if the farms of the country should be replaced at some time in the future by chemical laboratories.



IN THE March LUMBERMAN a Montreal correspondent asked for information concerning mahogany, chestnut and veneers. As a result of enquiries made at the time we replied that these woods were nearly all imported. I was glad to learn from Mr. H. S. Lusty, a lumberman, of Rodney, Ont., with whom I had a conversation a few days ago, that in Elgin Co., in which Rodney is located, that they have there an abundance of chestnut, and that Mr. Lusty handles it in large quantities.

James McBain Reid, Sec'y and manager of the Bradley, Morris & Reid company of Hamilton, has been two years in Canada, and obtained his lumber experience across the border. He does not think Canadians are quite as slow as they are charged with being but thinks they follow beaten paths too much, and are too well satisfied with what was good enough for their fathers, or what seems good enough for their neighbors. He would like to see better rates secured over American roads to Canadian centres, as a means of enlarging trade between the two countries.

"Less lumber is to be found on the piling grounds in the vicinity of Gravenhurst this year," said Mr. Jas. Tennant of this city, who had just returned from a trip in that section of country, "than for ten years back. Only two mills are running, and with these the cut is light. Reason of this? you ask. For one thing timber in that immediate neighborhood is becoming pretty well thinned out. The G.T.R. have had a share in shaping matters thus. For two or three years shippers in the north could not get cars from the railway to move their stocks. Stocks began to accumulate eating up interest until manufacturers became wearied cutting up only to store in their yards. Consequence was, they stopped. To-day we can get all the cars we want. I saw twenty or thirty cars on a siding when I was north a week ago waiting to be used, but no use for them. It is a case of chickens coming home to roost and the Grand Trunk knows it. My impression is that the principal mills in the Georgian Bay district will close down early this season. If so, this fact, along with the Ottawa strike, should stiffen prices.

At not unfrequent intervals I have given in this page the opinions of Canadian lumbermen on the duty question. One important purpose of the page is to cultivate a free expression of opinion on trade matters. We will get nearer the truth on any question by gathering all the information we can touching it; when the proper time comes we can do the sifting. We are going to hear this time from an American lumberman, Henry Moles, Jr. of the firm of Laing & Moiles, of Saginaw, Mich. In a chat with a reporter of the *Saginaw Globe* he said: Previous to the enactment of the McKinley law there was an export duty of \$3 placed on logs by the Canadian government, and a United States import duty of \$2 on lumber. The provisions of the McKinley bill took \$1 off the duty from the American tax providing that the Canadian government took off the entire export duty, and of course the dollar remaining is ample to pay the tow bills on the logs coming here. The result has been that the Canadian government has taken their duty off of logs, and they are being sent over to this country where the manufacture of salt and the sale of slabs, etc., makes it possible to compete with the Canadian mills in a way most disastrous to them, the towing being only 90 cents or \$1 per thousand. The consequence has been that these Canadian mills have lost the manufacture of an immense quantity of lumber in the Georgian Bay country and all along that district, and men are working for very small wages, in many cases for their board. There are laborers engaged in shoveling coal from the holds of vessels at Algoma Mills for 75 cents per day, where

last year they received \$3 per day. This state of affairs is, of course, due to the McKinley bill and logs coming here from Canada free. The fact that Americans can go from here over there and buy logs in such immense numbers and ship them in here has raised a howl on that side that is bound to have its effect. The Canadians have already made an appeal to their premier in regard to the matter, and he has told them that there will soon be a meeting of American and Canadian commissioners at Washington, and if the duty is not then taken off the lumber they would be obliged to take some action to protect themselves, and would surely do so. It looks as if the result will be that the entire import duty will be taken off by the American government as that is what the Canadian people demand. This will leave both logs and lumber on the same footing, and entirely free. If the duty is not removed the chances are that it will go back to \$3 per thousand where it was before.

One of the events of the month in lumber circles is the unfortunate strike among the millmen of the Ottawa district. I say unfortunate, for there never was a strike, be it big or little, of short duration, or long continued, that did not bring hurt upon all concerned, and on many others not concerned, nor in any way responsible for the act. But I am not going to enter into a discussion of the question of strikes right here. My anxiety has been to lay hold of some one from Ottawa, who could speak from personal knowledge and observation of the strike. I questioned one gentleman, who is a resident of the capital, and well posted on lumber questions in regard to a despatch that appeared in the *Toronto dailies*, saying that the mill owners had decided to close down for the season and that the strikers were leaving in large numbers for the States where work was being offered them. He said: "This report" very probably originated in the fact that the mill owners had remarked that they might have to resort to closing down for the season and some two or three men, who have shantied in the American forests; for the last three or four years, had gone over to occupy the same positions again this season." What will be the effect of the strike on the lumber trade, assuming the dead-lock to continue? "As nearly all of last season's lumber has been shipped," was the reply, "and the cut at Ottawa has been very much smaller this year, than other years, Pierce & Co.'s mill being shut down, the E. B. Eddy Co. having gone out of the lumber business, Jas. McLaren & Co. and Cassleman Lumber Co.'s mills being destroyed by fire, the latter reconstructed, only having commenced sawing again about six weeks ago, Buel, Orr & Hurdman's sawing delayed for want of logs, so that now should all have to close down it will make lumber very scarce, which means an advance in prices all round."

Regarding the merits or demerits of the strike, whichever way you like, I have the views of an Ottawa gentleman with which every one may not agree. But as LUMBERMAN readers know this kind of thing is rather enjoyed in this particular page. The ELI page is a free parliament where any one and every one may express their opinions on any question of interest to lumbermen. Sometimes I have to get after correspondents myself and give them a piece of my mind; and to any reader who feels like doing the same thing, we say come right on friend; you'll have every show in this page. The correspondent writes: "My impression is that the mill owners will give in to the demands of the men, perhaps not all they ask but they will make concessions. The men are not making any unjust demands, the most of the lumbermen would be willing to give them what they ask only they don't like the means adopted to get it. Perhaps those most directly affected by the strike are the exporters who have vessels waiting at Montreal or Quebec for loads; and of course it means probably a loss in circulation in this city of three or four thousand dollars daily. The effect on the lumber trade itself may not amount to much, although it means just that much lumber less to ship this fall, which along with the shortage in the season's cut may have the effect of increasing the price of lumber. I don't think the mill owners have any intention of closing their mills as they are anxious to cut for the balance of the season. As to men leaving for the States, I don't think very many

have left as yet although quite a number go over there for the winter and return in the spring. This occurs every year."

Somebody has been "stuffing" the *Northwestern Lumberman*, of Chicago, regarding Canadian lumber. I give the paragraph: "A dealer in this city who is conversant with the eastern trade estimates that the Canadians this year have captured the sale of 100,000,000 feet of the American trade through the operation of the new tariff and the favor that has been shown Canadian shippers by reduced rates on the Grand Trunk and its York state connections. The loss has been especially felt at Tonawanda and Buffalo, and by the hemlock operators in Pennsylvania. The Canadian mills had accumulated a great surplus of coarse stock that could not successfully compete with lumber on this side under the old tariff. Since the reduction of \$1 a thousand in the duty, lumber from the other side has flowed in freely, the Grand Trunk through rate regulation greatly helping in the process. The Canadians have thus been able to work off their accumulation doubtless to great satisfaction to themselves, but to the disgust of dealers and manufacturers at the east end of Lake Erie. In gathering stocks there they necessarily accumulate a large per centage of low grade common lumber, and depend on the eastern state trade as a means of getting rid of it. It was consequently a serious matter for Canadians to come in with their 100,000,000 feet as a competition. The hemlock interest of Pennsylvania has suffered in proportion to the territory affected. In this instance the American operators know that the reduced tariff has cost them money. One concern estimates that its direct loss this year from the cause indicated is \$15,000. The only way to even up the difference is to go to Canada for logs and lumber, and that is being done to an increasing extent." The *Montreal Trade Review* and the *Monetary Times*, Toronto have both copied the item; the latter however, with the comment, "that the estimate by the Chicago dealer is, without doubt, a gross exaggeration," adding enquiries made in this city show "that no more than 10,000,000 feet additional lumber has been moved over the Grand Trunk Railway into the United States this season as compared with former years." I took occasion in my intercourse with leading lumbermen in the city to show them the paragraph. "A hundred million is a big figure," said Mr. John Donogh. "It means a season's output of at least eight of our large mills. No such quantity was shipped from Canada. It is to be remembered that the drop in the G.T.R. rates was only temporary and made for the purpose of moving off the quantities of lumber that had been allowed to accumulate for want of sufficient cars previously. In the spring of the year, just as soon as navigation opened, the rates went up again. A maximum figure would be 10,000,000 or 12,000,000 feet." "With my knowledge of the shipments to the States" said Mr. Jas. Tennant, "I would say 10,000,000 feet would be outside figures. The Chicago journal was well filled up when 100,000,000 feet was talked to them." Our contemporary the *Monetary Times*, winds up its reference to the question in these words: "The dullness of trade frequently leads to magnified statements of this kind. The quantity of both 1889 and 1890 sawn lumber in the mill yards is proof, the inaccuracy of the statement. The coarser grades of lumber which found market in the States did not go over the Grand Trunk, but over the Canada-Atlantic Railway, and by water. The lower rates on these routes may have moved a larger quantity from that district; but from the west shipments have not been much in excess of former years. The increased distributing trade direct from the mills both in Michigan and Canada, and which continued throughout the whole year, is affecting central distributing points such as Buffalo, Tonawanda, Albany and Troy, more than any change in the tariff, or reduction in rate of freights."

Give fools their gold and knaves their power;  
Let fortunes bubbles rise and fall;  
Who sows a field or trains a flower,  
Or plants a tree, is more than all.



## OTTAWA LETTER.

THE MILLMEN'S STRIKE—3000 WORKINGMEN IDLE  
VISIT OF A PROMINENT ENGLISH LUMBER-  
MAN—BRITISH COLUMBIA LUMBER IN  
OTTAWA—NOTES OF THE TRADE.

[Regular correspondence CANADA LUMBERMAN.]

PARLIAMENT will have prorogued by the time this letter is in print, but the millmen's strike is still with us. On the morning of the 14th, inst., 1,500 men employed in the lumber mills of the Chaudiere went on strike, and this number has grown by accessions of men from other mills, forced into line since then, until to-day probably 3,000 men are walking our streets idle. The demand of the men is for shorter hours and increased pay. It is interesting to observe how working men in their demands seldom go it moderately. They would have every concession granted to them at the one time.

The hours of the men now are eleven and three-quarters; the request is for a ten hour day; and that wages be increased 50 cents per week. This does not at first thought appear an extortionate demand, but there are other factors to be taken into account, which no doubt will receive attention from THE LUMBERMAN.

The excitement for the first few days was intense. It is to be regretted that the mill-men resorted to violence and coercion to such an extent that the military had to be called out. I am not going to say how far circumstances, in this case or any other, justify a strike as a means of solving the troubles between employer and employed. Only decency and common fairness suggests that when a strike is proposed that the working men themselves shall say whether or not they shall be participants in it. In this case, and it is not the only case on record, the men who went out the first morning marched in hundreds first from one mill and then to another and by absolute force compelled the men who were diligently earning their daily bread to at once drop their work and come out. This occurred first at Booth's new mill where everything was in full swing and four hundred men were at work. From Booth's the strikers went to Mason's and did the same thing. Later Eddy's mill was attacked with the same result, but not until plucky resistance had been made by Mr. Eddy and his manager.

The usual program of all strikes has been followed out in the case of the millmen. Though not as thoroughly organized as some trades still much active organization has been perfected among the men within the past week. The "walking boss" and the professional labor agitator have been here—even your own Dan O'Donohue, Ottawa's whilom citizen. I can never see that these men do else than fan the flame of discontent in troubles like the present. What is wanted is calm council, a little common sense, and a measure of consideration, and that old staple medicine, "give and take," and by these means such troubles as are now worrying our people are more likely to be settled.

At this writing no settlement has been reached. The Shepherd & Morse company have resumed work. In this case it is claimed a mistake was made in calling out the men as they had only been working ten hours a day whilst their lowest rates of wages was \$7.50 and the highest \$10.50. The general situation, however, remains unchanged, and whilst the hope is entertained that a speedy settlement will be reached it does not look over probable. Be it not and a bleak Christmas is in store for a host of men, women and children in this section of the Dominion.

## OTHER LUMBER MATTERS.

Mr. J. W. Todd, lumber merchant, of Liverpool, Eng. was in the city during the month. This gentleman is an extensive purchaser of Canadian lumber and his visit was purely of a business character. Speaking on the lumber business in general Mr. Todd made a rather significant statement to an interviewer. He said that in England lumber dealers consider the statements made on this side respecting the shortness of lumber here to be greatly exaggerated. Many of them he said would continue to be credulous till they realize the truth by actual experience. Quite recently, however, a few of the buyers who are better informed on the condition of the markets here, have wakened up and have commenced purchasing. The stocks in the old country

which have been low for the past year still remain low, but the prospects are that they will take a jump in the near future. The market now is hardening for pine lumber and timber. In view of the real conditions of the market which have been understated rather than exaggerated by the press on this side of the Atlantic it is fortunate that Mr. Todd has been with us to learn for himself that it is a fact that not for years has the piling grounds of every leading centre in the province been so bare of saleable lumber. Speaking of Mr. Todd's transactions in Canada it is opportune to note that Watson & Todd of which firm he is a member have purchased the entire cut of deals of Messrs. Buell, Orr, Hurdman & Co., of this city.

On the 9th of the month a car load of lumber unloaded at the C.P.R. from the mills at New Westminster in which Mr. J. W. McRae has a large interest, the material being intended for use in the new stables in course of completion on that gentleman's property on Elgin and Lisgar streets. The shipment comprises a quantity of red cedar shingles of excellent width and cut from timber that is perfect in construction, the great beauty being that this wood will not warp. Besides this there is a lot of spruce sheeting, for flooring and the ordinary millrun of red cedar ranging from two to five inches in thickness and some of it thirty inches wide. This lumber when oiled and varnished will present a beautiful finish as the grain is remarkably clear and well sustained throughout. Mr. McRae states that despite the high rate of freightage this lumber can be laid down in Ottawa at a good profit. It is as fine a car load of mill produce as can be found on this continent.

A feature of work in the woods this season will be the number of broad-axe men who will be employed, owing to the increased quantity of square timber that will be taken out in the bush.

Messrs. Bronson & Weston now have most of their men in the bush. The firm have two shanties on the Dumoine river, and two at Rockliffe, and four on the Quinze. They will likely put in several on the York branch, bringing the number up to twelve or thirteen as against eight or nine last year.

The full capacity of the machinery in the new Eddy paper mill is equal to 180 to 200 feet by 72 inches in width per minute. This company are also making their new matches out of cardboard, manufactured in the same mill as that in which the paper is made.

J. R. Booth has made some extensive repairs recently by fixing up the docks and blasting away rock to make more room for piling.

Bidou Renand, the well known lumberman's agent of Murray St. has sent as many as two hundred men to the shanties in one week. He is signing wood choppers as rapidly as he can secure them. Most of the men are from the Province of Quebec.

Ottawa, Sept. 28, 1891.

## TRADE NOTES.

The Wm. Hamilton Manufacturing Co., of Peterborough have established an agency at Vancouver, B. C. Robert Hamilton remains in charge. A British Columbia exchange says that when business increases the company proposes to erect a foundry and machine shop in the province.

The Magnolia Anti-Friction Metal Company has a very pleasant habit of now and then remembering their friends with something useful or ornamental, or more often a combination of both. Their latest souvenir is a sixteen inch rule for desk use, of the best pattern and make, the receipt of which THE LUMBERMAN gratefully acknowledges.

John Pell Northey, manufacturer, John Leys, merchant, Arthur Brindley Ley, merchant, Arthur Burdett Lee, accountant, and Harry Sutton Pell, insurance inspector, all of the City of Toronto, have made application for letters patent incorporating the Northey Manufacturing Company (Ltd.) incorporation being sought to manufacture and deal in pumps, engines, boilers, machinery and all other articles made wholly or in part of iron or other metals and to deal in iron and other metals.

## BRITISH COLUMBIA LETTER.

STATE OF TRADE—EXPORT SHIPMENTS—A LARGE  
CARGO—TIMBER PRODUCTS OF THE PROVINCE.

[Regular Correspondence CANADA LUMBERMAN.]

EVERYTHING in lumber circles continues very quiet. The Vancouver mills are still loading ships for export, in spite of the dull times. The *Atahapuy* chartered by the MacLaren & Ross Co. for a cargo load for Australia is being loaded at the Brunette saw mills on MacLaren-Ross account. This is deemed wiser than to put the big mill into motion to cut a hundred million. Local trade continues good as is the N.W.T. and Manitoba business.

A local company has been formed to erect a mill on Barkley Sound, Vancouver Island, with a capital of \$500,000. In addition to all kinds and grades of paper, pulp will also be manufactured.

A Norwegian steamship is loading lumber at Moodyville for Port Pirie, Australia, and will carry 2,000,000 feet. We cannot recall a larger cargo. Do you know of one? It is supposed she will make the trip in 37 days.

The agitation begun by the New Westminster Board of Trade to have B. C. lumber sold and quoted as "Douglas Fir" instead of "Oregon Pine" has received the full approval of the Vancouver and Victoria Boards of Trade as well as several large shippers. Several Australian ports have replied endorsing the movement and admitting that "Douglas Fir" is superior to "Oregon Pine" in every way.

We have strong hope that the export trade in general will revive this fall. Fine crops in the east, together with the cessation of the Chilian troubles should lead to a large number of orders before many months; and we hope an advance in prices.

## OUR LUMBER WEALTH.

I sometimes think that those who do not know British Columbia experimentally hardly realize the wondrous timber wealth that is born of this province. In this respect the language is moderate when I say that no other province in Canada, no country in Europe and no state in North America can compare with it. The finest growth is on the coast and in the Gold and Selkirk ranges. The Canadian Pacific Railway passes through a part of this and crosses streams that will bring untold quantities to the mills and railway stations. The species of trees found in British Columbia are as follows: Douglas fir, western hemlock, Engleman's spruce, Menzie's spruce, great silver fir, balsam spruce, white pine, giant cedar, yellow cypress, western larch, maple, aspen poplar, mountain ash and others. Of these probably the best and most in demand is Douglas fir. It is straight though coarse grain, exceedingly tough, rigid and bears great transverse strain. For lumber of all sizes and planks it is in great demand. Few woods equal it for frames, bridges, ties and strong work generally, and for shipbuilding. Its length, straightness and strength specially fit it for masts and spars. Masts specially ordered have been shipped 130 feet long and 42 inches in diameter octagonally hewn. It grows to an enormous height, frequently from 250 to 300 feet, and often exceeds 8 feet in diameter. It is only a matter of some 30 odd years since the first sawmill was put up at Burrard Inlet and now there are mills scattered all the way from Williscrafts, near Port Simpson, down to Martins of Clover Valley, and many of which are shipping their products to Australia, South America and to ports even on the Atlantic seaboard. Our three large towns Vancouver, Victoria and New Westminster have each grown rapidly within a few years, and this growth is due in a great measure to the development of the lumber industry. In New Westminster we have five mills established, employing altogether about 600 men, a third of whom are married and have families, thus making the probable population supported by this industry in town about 1,500. Besides lumber you are aware that the wealth of the mine and the richness of our streams are likewise valuable factors in the progress of this province, but I have briefly sketched the lumber industry as that in which your readers are more particularly interested.

H. G. R.

New Westminster, B.C., Sept. 23, 1891.

## THE NEWS.

## ONTARIO.

—All four mills at Staples are very busy.

—C. H. Staintor, builder, city, has assigned.

—Jayue's shingle mill at Sturgeon Bay is closed down.

—F. W. Schwendiman, planing mill, Dayton, burned out.

—Operations at Cook's mills, Thessalon, are expected to be brisk this year.

—Buel, Orr, Hurdman & Co. have two shanties under way at Deux Rivieres.

—W. J. Church, a builder in a small way at Ottawa, is reported insolvent.

—The Waubashene mill at Waubashene, will run until the end of October.

—Benson & Grinnell, of Penetanguishene are shipping hardwood lumber to Germany.

—The Rainy River Boom Company has handled 35,000,000 feet of logs since May.

—T. B. Tait, of Burk's Falls, is doing a good trade in shingles for the American market.

—C. Young, of Young's Point, is shipping basswood in considerable quantities to the States.

—Warren has had an increase of 300 in population—men employed by the Imperial Lumber Co.

—Lumbering operations in the Parry Sound district are expected to be brisk the coming winter.

—At Penetanguishene, the C. Beck Manufacturing Company have stopped sawing for the season.

—Brennen's mill, Huntsville, which has been idle all summer is being fitted up by George Marskell.

—W. Perdue, of Goderich, has purchased the portable saw mill formerly owned by Perdue & Donaldson.

—W. O. Emory and Thos. Pickard, of Wahnapiatae are conducting large operations in the Sudbury district.

—The mills generally, at Huntsville, will shortly close down, the supply of logs being pretty well exhausted.

—The new shingle mill at Sturgeon Bay, on the site of the old mill which was burned down is doing good work.

—Menzie's millmen at Berriedale are busy completing a contract of 130,000 feet of lumber for sidewalk purposes.

—The local paper at Bracebridge writes rather discouragingly of the prospects for lumbering this fall and winter.

—M. Boyd & Co., of Bobcaygeon ship annually about 10,000,000 feet of white lumber to their yard in Albany, N. Y.

—Mailloux & Co., of Stoney Point, saw mill men, have dissolved partnership. Clement Mailloux will carry on the mill.

—Richard Olmstead's mill at Walter Falls, which is undergoing important improvements, will be in running shape about Nov. 1.

—The Keewatin Milling Co. are about to erect a stave factory on the Rainy river, where there is excellent timber for staves.

—Charles Logue, Maniwaki, has commenced operations for the season on his limits on the Gatineau river, ten miles from Maniwaki.

—The Red Mill at Manitoulin has contracted for the logs which will be cut this winter on the Indian reserve at Wekeoimikony.

—J. Milne, of Essex Centre, is negotiating with Michigan men for the formation of a company to manufacture hollow blast grates for saw mills.

—Rochester Bros., of Ottawa, are operating on Horse Island, Manitowaning. An exchange says their clearings will include rattle snakes as well as timber.

—The Rathbun Co., of Deseronto, have purchased the old McDougall mill at Harwood and are removing the machinery and building material to Deseronto.

—The capacity of the Lindsay shingle mill of A. W. Parkin & Sons, is 60,000,000 a day, and the firm controls the cut of five other mills adjacent to the town.

—W. A. Frazer, of Suspension bridge, has leased yard room at Tonawanda, N. Y., and will open a yard there. He has a saw mill in Canada and Michigan.

—The Ontario government offer for sale a large quantity of standing pine timber west of Sudbury. The official advertisement appears in our advertising pages.

—Sage & Emory, of Bay City, Mich., have the contract for cutting the lumber on McArthur Bros' limits, twelve miles back of Thessalon, and will run four large camps

—McLaughlin Bros., of Arnprior, have given a large order for harness to the local harness maker to be used by the heavy teams employed by this firm in logging operations.

—Stocks at the mills at Severn Bridge will be well reduced by the time the weather makes it desirable to close down. A good average trade is reported for the season.

—M. V. Ranger, of Ottawa, has sent a gang of men to the limits of the Georgian Bay Lumber Company on the French River. The wages paid vary from \$16 to \$23 a month.

—The mill at Thessalon has again commenced cutting, sufficient logs having been obtained to keep it running until the logs which have been "tied up" in the creeks are brought down.

—Bobcaygeon has supplied a fair quota of the men for the lumber camps on the north shore of Lake Huron. Wages are a trifle higher than last year, running from \$20 to \$24 a month.

—The steamer *Empire* made a trip to the Rainy River boom and returned with a tow of logs of 1,200,000 feet in four days and twenty-two hours. This beats any previous record.

—J. Beck, Sec.-Treas. of the Beck Lumber Company has taken to the woods with a gang of twenty-six men and teams. Their winter's work will be in the vicinity of Webbwood on the French River.

—The estate of J. P. Snook, builder, of this city, who has been compelled to consult his creditors, is likely to pay 100 cents on the dollar. The trustees' statement shows a surplus of \$3,806.

—An assignment has been made to Campbell & May by McGeary & Co., planing mill men, of this city. The liabilities are placed at \$8,000. M. Dymond, of Barrie, figures as the principal creditor.

—It is expected that a larger quantity of paper wood than usual will be taken out this winter in the vicinity of Thessalon. White & Myers, local dealers, and G. A. Burton, of Appleton, Wis., are the principal operators.

—The Parry Sound Lumber Company at Parry Sound, are building a new dam to replace the old one at their water mill. Part of the old dam which they are now tearing away was built thirty-five years ago, when lumbering was first commenced in that vicinity.

—At Osgoode Hall, on 15th ult., Alphonso Charlebois obtained a continuation of the injunction against the Great North-western Central, preventing the railway company from selling their 300,000 acres of Crown Lands, or disposing of their bonds. Charlebois intends to press his action for \$75,000 against the railway company. On 29th ult., an agreement was arrived at by both parties, and all suits dropped. The agreement was ratified by Mr. Justice Ferguson.

—R. S. Donally, bush and fire ranger for the Emery Lumber Co., reports that he saw several wild animals in the woods near Sudbury. The first was a young lynx. Two hours later he came across a moose deer. He had a more exciting venture afterwards when he came upon a bear. It looked like fight at one time and Donally was in a tight corner. But Bruin decided to move on, followed by a couple of shots from a 32-calibre revolver. Mr. Donally says there is no water to be found in the small creeks and he travelled from ten o'clock until five in the evening before he could get water to drink.

—Recent storms have caused serious loss to some lumber concerns. The *Mocking Bird* lost a tow of the Emery Lumber Company off French River, but got it all together again and made a safe trip to Michigan. A small tug belonging to the Beck Manufacturing Co., of Penetanguishene, was less fortunate and lost considerable of her stock. The barge, *Louis Hotchkiss* was lost in Lake Huron with a full cargo of lumber. She was the property of the Muskoka Mill and Lumber Co., and was valued at \$30,000.00. The cargo, valued at \$10,000, was fully covered by insurance, but there was no insurance on the hull, which is a total loss to the owners. This boat has been running since 1871, and this is her first and last loss. The cargo consisted of lath and lumber amounting to 1,196,000 feet. The steam barge *Lothair*, loaded with lumber from French River foundered a few miles out of Tobermory harbour. The vessel is water-logged, and but for the lumber she carried would have sunk. Tugs *Clucas* and *Seagull*, towed her into the harbor where she will be unloaded and pumped out. At the time she foundered the weather was favorable and the cause of the disaster is unknown. The *Resolute* which got a bad shaking up at the time of the *Mocking Bird* disaster is in such a condition that her crew have refused to take her out again and she will have to be rebuilt.

## QUEBEC.

—Preparations for the winter's lumbering are active.

—Butle & Brodeur, saw mill, etc., Waterloo, have dissolved.

—J. B. Herbert of Fulford, has disposed of his saw mill to a friend.

—The Bonnallie saw mill in the township of Oxford has been sold to E. Marshall & Co., of Sherbrooke.

—A rumor has it that an American firm is negotiating with the two leading lumber firms of Buckingham with a view to purchase.

—Richard Ready, lumber merchant, Montreal, Que., has assigned with liabilities of about \$16,000. The Rathbun Co. of Deseronto are among the creditors.

—The Buckingham Manufacturing Company (limited), with a capital of \$80,000 has been incorporated, a number of Montrealers being the promoters. Their objects are to deal in wood pulp paper.

—According to figures published by the Quebec government it is estimated that there have been produced in the province during the twenty-three years from 1867 to 1890 inclusive, 11,173,516,549 feet of lumber, and 70,272,572 cubic feet of timber, while \$10,764,368 have been paid over to the government as timber dues.

—Elie Lachance was at one time in the dry goods business at Levis. In this he proved unsuccessful, and in 1889 he moved to St. Praxede where he started a saw mill and general store. His capital was very limited, and as things seem to have run the wrong way for him during the past year, he has been obliged to take refuge in an assignment.

—In addition to the big saw mill which the Eddy Company has converted into a paper mill, the construction of a stone store house 10x75 feet long has been commenced. It will front the present mill at Hull and be three stories high, and will be used to store paper and the company's other wares. A substantial boiler house with a monster smoke stack 130 feet high is also under way, at the Devil's Hole.

—There is a most marked decline in the export of the square timber from the port of Quebec this year as compared with 1889 and 1890. The falling off has not been restricted to white pine, as in oak, elm, ash and birch and maple there has been a corresponding shrinkage. The following statement in cubic feet, of timber measured and culled up to the first of September at the port of Quebec this year, as compared with the two preceding years, shows at a glance how this once profitable branch of the lumbering industry has declined:

	1889.	1890.	1891.
Waney white pine.....	2,811,842	2,868,730	1,339,358
Red pine.....	612,175	97,808	34,269
White pine.....	3,477,910	2,127,792	842,149
Oak.....	960,188	843,036	653,258
Elm.....	705,430	486,055	471,349
Ash.....	229,540	92,787	76,240
Birch and maple.....	365,980	163,377	126,666

## NEW BRUNSWICK AND NOVA SCOTIA.

—Meteghan River Lumber Co., Meteghan River, N. S., is in liquidation.

—An extensive shingle business has been done this season at Morrison's mills, Frederickton, N. B.

—Kelly Bros., of River Herberth, N. S. out-put this season has been 2,700,000 feet of lumber and 2,300,000 lath.

—Messrs. Rees & Lozar of Colchester South, N. S. have succeeded in getting water to their mill from the M. C. R. R. reservoir and have resumed business. They have a good stock of logs in their yard, and there is every probability of the mill running steadily until the end of the year.

—Hundreds of citizens of St. John, N. B., were attracted to the corporation pier of that city a few days since to see the big ship *Canada* take her departure for Liverpool. She takes 1,580,500 feet of deals and battens 31,154 feet of scantling, 104,155 feet of ends and 165,701 feet of boards. The value of her cargo is in the vicinity of \$144,109. The tug *Storm King* towed the ship down as far as Musquash.

—A statement published in the *Moncton Times*, N. B., shows that the wooden ship-building industry in Nova Scotia is not dead. Says that journal: In 1887 Nova Scotia built 37 vessels, of 12,300 tons. In 1888 that province built 116 vessels, 12,900 tons. In 1889 she built 106 vessels, 16,645 tons. In 1890 no less than 148 vessels, 33,749 tons. Some of the vessels lately turned out of Nova Scotia yards are among the finest wooden ships afloat.

## MANITOBA AND THE NORTHWEST.

—The Minnesota & Ontario lumber mill at Norman, has closed down. The planing mill is still running, and the yard and office men are busy shipping. The season's cut has been a large one.

—Rafuse Bros. are running a successful saw mill at Riversdale, Assa.

—Fraser & Co., Edmonton, Alberta, are sawing in the neighborhood of 1,000,000 feet of lumber this season.

—Activity prevails at Christie's mills, Brandon. Seventy-five men are constantly employed, and the turn out is 60,000 feet of dressed lumber every twenty-four hours. 42,000 logs are on hand and 2,100,000 feet of lumber. 40,060 feet of lumber leaves the yard daily for different parts of the province.

—The Western Retail Lumberman's Association has been organized embracing all the retail lumber merchants of the province. The following are the officers: President, A. Black, Winnipeg; vice-president, Mr. Barclay, Brandon; secretary-treasurer, Mr. Housser, Portage la-Prairie. Five directors were also appointed, who, with the president and secretary-treasurer, form the executive committee.

BRITISH COLUMBIA.

—James Tretheway will erect a saw mill at Chilliwack.

—Five logging camps north of Victoria have shut down and the men have been paid off on account of dullness in the lumber trade.

—Capt. Armstrong's lumber mill near Golden, has received a large new planer.

—Purdy & Dixon will shortly begin operations at their new saw mill at Mission City.

—The Cornwall mill, at Whatcom, is now cutting 100,000 feet per day and has over 2,000,000 on hand ready to load in anticipation of the arrival of two vessels from Chili.

—J. A. Carthew contemplates the establishment of another first-class saw mill on the Skeena river, and a few days ago placed a contract for the necessary engines and plant with the Hamilton Manufacturing Company, of Peterboro. The new mill is to have a daily capacity of 50,000 feet.

—Col. J. Y. Scott of Port Moody, who owns a large ranch near Westminster Junction, made an interesting discovery a few days ago. Trees in the woods were found full of honey, each containing an enormous quantity of wild honey. One taken down one night held 400 pounds deposited in the cavity of the cedar, 10 feet long and 18 inches in diameter. The Colonel expects to get a ton of honey this Fall. It has a better flavor than hive honey.

—The shipping intelligence of the month tells of the Chilean ship Atacana, 1,235 tons on the way from Valparaiso to Moodyville to load a return cargo of lumber on owners account. The Chilean ship Emma Louise, 1,480 tons has been chartered to load a cargo of lumber at Moodyville for Valparaiso. The Norwegian steamship Herman Wedal Jarlsberg, 1,958 tons, arrived at Moodyville Sept. 4 from San Francisco to load a cargo of lumber for Port Pirie. The Norwegian ship Saga, 1,413 tons, Capt. Oftedahl, cleared from Vancouver Sept. 3rd, with a cargo of lumber from the Moodyville saw mill for Sydney, N.S.W., consisting of 960,254 feet rough lumber, 22,461 feet t & g flooring, 2,277 bundles of staves and 1,414 bundles of laths.

MEASURING TIMBER.

THE usual rule for calculating timber, is to measure the trunk round the middle, take one-fourth part of the girth and square it, and then multiply such square by the height of the tree. In calculating a standing tree, it is usual to measure the height of the tree to the first fork, and if there is still a good portion of trunk above that, it is measured separately and added to the previous calculation. If a tree is very irregular, divide it into several lengths and find the contents of each part separately; or add all the girths together and divide the result by the number of them to find the mean. When the square of the quarter-girth is multiplied by the length, the product gives a result nearly one-fourth less than the true quantity in the tree. Some allowance ought to be made to the purchaser on account of the waste in squaring the wood, so as to be fit for use. Dr. Hutton recommended the following rule, which will give the contents extremely near the truth: "Multiply the square of one-fifth of the girth by twice the length, and the product will be the contents." It has been estimated that forty years growth is required to produce one load of timber.

—The large sale of yellow pine made by Messrs Lacey and Wellman to the German government will probably be a big factor in strengthening the yellow pine market, more especially if arrangements now pending, looking toward a sale of 150,000,000 feet more, are successfully completed.



—Michigan lumbermen are embarking to no small extent in Southern timber limits.

—Over 100,000 trees in forest reserves in South Australia have been lately destroyed by grasshoppers.

—Cleveland's trees are being killed by soot, and it is feared that she will soon lose her title of Forest City.

—Terrible forest fires broke out in Northwestern Minnesota on the 23rd, ult., destroying immense quantities of timber land.

—The Michigan Hoop Company expects to handle 10,000,000 hoops at Clare the coming year, and contemplates erecting a mill at that point.

—At Saron, Texas, a plant is being erected that will manufacture from sawdust and pine slabs, alcohol, creosote, tar, pitch, turpentine, and charcoal.

—The early closing down of all lumber mills at the head of Lake Superior is probable. The cause is lack of logs in the Aminincon and Middle rivers.

—The three tallest trees in the world are believed to be a sequoia near Stockton, California, which is 325 feet high, and two eucalypti in Victoria, Australia, estimated to be 435 and 450 respectively.

—With millions of logs hung up in the Wisconsin and Minneapolis streams logging operations should not be very brisk next winter. But it is a difficult matter to curb the ambition of the average logger.

—The Morton & Backus Lumber Company, of Detroit, Mich., one of the largest institutions of the kind in the city, is temporarily embarrassed. Chattel mortgages aggregating \$81,040.17 have been filed in the office of the city clerk. Nearly all of the mortgages have been given to secure the payment of promissory notes given at three months.

—The Upper Congo abounds in forests, and many of the woods would prove of value in Europe. Mahogany and ebony, camwood, and a timber almost as strong as teak, known locally as ironwood, are found in the interior, but the question of transport stands in the way of their being utilised by commerce.

—Choice logs are said to be scarce along Puget Sound this season, owing to a short cut brought about by a poor demand. It is estimated that there are less than 30,000,000 feet of marketable logs in rivers tributary to the Sound. As a consequence, prices are stiffening, and choice logs bring from \$7.50 to \$9.50, a rise from \$6 to \$8 at which prices they were quoted a short time ago.

—There are 413 species of trees found within the limits of the United States and territories, sixteen of which, when perfectly seasoned, will sink in water. The heaviest of these is the black iron wood, found only in southern Florida, which is more than 30 per cent. heavier than water. Of the other fifteen, the best known are the lignum vitæ and the mangrove. Texas and New Mexico lands, full of queer, creeping, crawling, walking, and inanimate things, are the homes of a species of oak which is about one and one-fourth times heavier than water, and which, when green, will sink almost as quickly as a bar of iron. It grows only in mountain regions, and has been found westward as far as the Colorado desert, where it grows at an elevation of 10,000 feet.

—With the close of the present season, the H. W. Sage & Co. mill at West Bay City, Mich will have finished cutting all the stock of timber at present owned by the firm. This mill was erected in 1865, and will have the best record of any mill on the river when it closes the season, a cut of 700,000,000 feet of lumber, valued at nearly \$11,000,000. In the decade ending with 1890, the mill manufactured 416,445,251 feet of lumber, as follows:

1880	25,048,987
1881	20,121,264
1882	31,500,000
1883	30,000,000
1884	28,000,000
1885	20,000,000
1886	30,000,000
1887	30,000,000
1888	33,000,000
1889	30,000,000
1890	28,275,000

Total ..... 416,445,251



FIRES.

James Dollar's storehouse and stables in Bracebridge have been burned. Loss \$1,000.

Mackay & Co's saw mill, one mile west of Griffin Lake, was burned to the ground on the 14th, ult.

Large mountain fires lately destroyed millions of feet of good timber in the Kootenay Valley, B. C.

A fire on the 14th ult., destroyed Robertson's lumber shed at Metcalfe, Ont. Loss \$700; no insurance.

The shingle mill on Muskoka Bay owned by A. L. King was burned to the ground a week ago. Insured for \$2,000.

Hilliard's shingle mill, Peterboro, Ont., was burned to the ground on the 21st, ult. Loss \$2,500. No insurance.

The planing mill of F. W. Schwendrinan, Drayton, Ont., together with 10,000 feet of lumber have been destroyed by fire. Loss \$5,000.

Rollister & Jewitt's saw mill and a large quantity of lumber at Garden River, Ont., was destroyed by fire a fortnight ago. Loss \$200,000; insurance light.

The mills of the St. Lawrence Lumber Co. (Ltd.) of Bathurst, N. B. were totally destroyed by fire on the night of the 23rd, ult., together with a large quantity of lumber. Mr. K. F. Burns, M. P. for Gloucester, N. B., is the general manager of the company, and was in Ottawa attending his parliamentary duties when the fire broke out. Our readers will remember that we printed a cut and sketch of Mr. Burns in the June LUMBERMAN.

CASUALTIES.

John Holbert of Burk's Falls, Ont., while at work in his saw mill, had one of his thumbs cut.

A boy named Henry Brodhayen, had his arm broken in Bettscher's planing mill Palmerston, Ont., a week ago.

Robert Rusk, of the cedar mill, Deseronto, Ont., is suffering from a disabled arm through being struck by the shaft of a saw.

A native of Switzerland, named Emiel Hackstrosser died a week ago from the results of an accident in Busie's saw mill, Vancouver, B. C.

A logger named Charles Levva employed in Mackies camp on Valdy Island, B. C. died suddenly on 23rd, ult. He had recently come from Marysville, Cal.

A man named Brown in the employ of the Royal City planing mills, New Westminster, B. C., had his left hand badly cut and torn by a circular saw a few days since.

A young man named Arnett who was working at Thompson & Baker's mill, Oakley, Ont., had one of his arms nearly cut off a few days ago by the saw of a shingle machine.

Felix Logon, an employee in Cameron & Kennedy's mill, Rat Portage, Ont., was struck by a shingle bolt in the abdomen, and died the following day from his injuries.

A son of John McConachie, owner of a saw mill at Huntsville, Ont., received an ugly wound in the knee on the 5th, ult., by coming in too close contact with a shingle saw.

Thos. Callaghan, superintendent of the Rathbun company's operations on the Trent river had his leg broken while driving from his office to the railway station at Campbellford, Ont.

Thos. Sheridan, assistant in the Rathbun agency in Brockville, Ont., died of lockjaw on the 15th, ult. Deceased was unmarried, 35 years of age, and a very competent man in the lumber business.

A broken leg has come to Andre Toussaint, a young man employed in J. R. Booth's mills, Ottawa, Ont. He was at work on the mill platform and his leg was caught between a stock of lumber and the rollers.

George Peterson, a logger, working for David Conklin, Gosfield, Ont., was nearly killed a few weeks ago. The logs of a truck with which he was working became loosened, striking him with terrible force on the face. He will be disabled for life.

Some operators make endless leather belts by using common glue to make the joint. One of the advocates of this method says: "Bevel the ends nicely and smoothly. Put the glue on and place the splice in a vise for some time. I have had such splices on the heaviest kind of work, but it has never yet failed to hold."



TRADE REVIEW.

Office of CANADA LUMBERMAN }  
Sept. 30, 1891. }

THE GENERAL SURVEY.

**B**ARRING the Ottawa strike no disturbing elements mark the lumber trade of the month. A somewhat improved business is shown, and the trade has reason to expect at least a fair business this fall. The crop in Ontario, as indeed is the case in all the provinces, is well harvested and shows up a splendid quality. Prices are ruling satisfactory, we should think, to the farmer, and in a few weeks when he commences to sell, money must necessarily circulate with some freedom. A commercial writer whose trade experience and careful judgment usually lends accuracy to his calculations, fixes the result of the harvest, the Dominion over, at \$25,000,000 in excess of last year. It will be passing strange if lumbermen do not get a slice of this. In the meantime collections are slow.

Not much, if any, increase in business may be expected from Toronto this side of next spring at any rate. Building operations that will benefit the lumber trade may show a revival then, though we have houses enough and to spare for some time to come. Two or three failures of small contractors and planing mill men have occurred during the month, but the liabilities have been light and caused no serious worry to anyone in particular. The firm of contractors whose case was referred to in the September LUMBERMAN continue to sail in deep waters, seemingly indifferent whether they sink or swim. Creditors are endeavoring by various ways to collect their money, but we fear the shot in most cases strikes a bullet proof armour.

Business in the country is quite healthy. Jobbers say that an encouraging movement is shown around out-town yards, and buying will be free for some months.

Canadian lumber is being shipped in good quantities to the States with the outlook for continued and stronger shipments in October. Prices remain firm.

What will be the result of the Ottawa strike on prices? This will depend on the outcome. At this writing it looks as if the dead lock would continue, and if so, it is not improbable that the mills will at once close down for the season. THE LUMBERMAN has taken some trouble to ascertain the views of the trade both in Ottawa and in the west based on this contingency. The consensus of opinion appears to be that no immediate effect of any importance will be experienced in lumber circles generally. If the mills continue closed down the season's cut will be necessarily curtailed and this would have the effect of stiffening prices of stocks on hand; it is the case, however, and especially in the Ottawa district, that these stocks are very light. That better prices will prevail in the spring, as a result of these conditions seems more than likely. One correspondent, who is in a position to know says: "Our opinion is, assuming that the mills shut down for the balance of the season, that the effect would be purely local; better prices would be obtainable for such lines of this season's manufacture, as are yet unsold, and a much brisker trade would begin in the spring. Also in view of the cessation in shipping, greater activity will prevail during the fall and coming winter. We do not see how any effect on the lumber market in other centres can result from the strike in this locality."

Of Canadian trade as a whole, taking a diagnosis of the conditions at all the various controlling centres, it can be said that the patient is in a fairly healthy state, with the probabilities pointing to continued and increasing strength.

NEW BRUNSWICK.

Business in New Brunswick is recovering from the effects of the strike a few months since. The mills are all running and shipments to the United States and Europe are fairly brisk. Work for the winter is commencing to engage the attention of the lumbermen of this province, and more than one large operator has despatched gangs of men into the woods to prepare for operations. Fredericton is experiencing quite a shingle boom, the mills in this vicinity being kept very busy. The Canadian Pacific railway track runs right alongside of Morrison's shingle mill, and this company has made special rates for the shipment of shingles to the Boston market, with the result that immense quantities are being sent forward.

MANITOBA.

Mills in Manitoba and vicinity are commencing to close down for the season, though a good trade is anticipated as soon as the pressure of harvesting and contingent work is completed. The question sometimes arises in lumber circles, how do prices run in the west as compared with other markets? To answer this we give here the price list, f.o.b. at Lake of the Woods mills, 60 days, or 2 per cent. discount in 30 days: Dimensions—2x4 to 12x12, 18 feet long, \$14; do., 10 feet long, \$15; cull dimension, \$10; \$1 per M advance on each inch over 12 inches in depth and width; 50c per M advance on each foot over 18 to 24 feet. \$1 per M advance on each foot over 24 feet long. Surfacing, 50c; sizing, \$1; dressing 4 sides, \$2. Boards—1st common rough, \$16.50, dressed, \$17.50; 2nd do., rough,

\$14, dressed, \$15; 3rd do., rough, \$12; dressed, \$13; culls, rough, \$10, dressed, \$11; 1st common stock, 12 in., rough, \$19; dressed, \$20; do., 8 and 10 in., rough, \$18; dressed, \$19; 2nd do., 12 in., rough, \$16; dressed, \$17; do., 8 and 10 in., rough, \$15; dressed, \$16; wide box boards, No. 1, rough, \$19; dressed, \$20; do., No. 2, rough, \$16; dressed, \$17. Shiplap—6 inches, \$14; 8 and 10 inches, \$16; cull, \$12. Siding, ceiling and flooring—1st, 4, 5 and 6 inches, white pine, \$31; do., red pine, \$26; 2nd, 4, 5 and 6 inches, white pine, \$27; do., red pine, \$24; 3rd, 5 and 6 inches, white pine, \$23; do., red pine, \$20; 3rd, 4 inch, white pine, \$22; do., red pine \$19; 4th, 5 and 6 inch, white and red \$15; do., 4 inch, white and red, \$14; culls, white and red, \$10. \$1 per M advance for dressing both sides, \$2 per M less for lengths 10 feet and under. Bevel Siding—No. 1, 1/2 in. x 6 in. white pine, \$20; No. 2, white and red, \$17. Finishing—1/4, 1/2 and 2 inch. —Clear white pine, 1st and 2nd, \$45; 3rd, \$37; selects, white pine, \$30; shop, do. \$25; clear red pine, \$27; selects, do. \$22. 1 inch white pine—1st and 2nd clear, \$40; 3rd, do., \$32; 1 in. selects, \$20; 1 in. red pine clear, \$25; No. 1, stock, white pine, 12 in., \$37; No. 1, do., 8 and 10 in., \$35; No. 2, do., 12 in., \$32; No. 2, do., 8 and 10 in., \$30; No. 3, stock, white and red pine, 12 in., \$26; No. 3, stock, white and red pine, 8 and 10 in., \$25. Moulding—Parting strips, per 100 feet lineal, 40c; window stops, do., 50c; door stops, do., 75c; 1/4 round and cove, do., 50c; 4 in. casing, O.G., per 100 feet lineal, \$1.50; 5 in. do., \$1.90; 6 in. do., \$2.25; 8 in. base, \$3; 10 in. base, \$3.75. Mouldings not mentioned above at 45 per cent. off prices in universal moulding book. Lath, \$2. Shingles—No. 1, \$3; No. 2, \$2.25; No. 3, \$1.50; No. 4, \$1.

BRITISH COLUMBIA.

Whilst British Columbia continues to feel the shrinkage in export trade to South America, yet the past month has shown signs of improvement in this direction. There is a strong feeling that matters are coming round again in this market. The financial troubles of the year are shaping better and the hope is that the mills on the Pacific coast will ere long resume their old time activity. As it is, several shipments of no mean size have left here for South America during the month, and others are in preparation. Australian trade is not heavy, at the same time it has not counted an entire blank. There has been more or less shipping to Sydney and other points since our last review of the trade here. Local trade moves along in the ordinary way, a fair business being done with plenty to do it. The disposition of some mills to cut rates is quite manifest. Prices are quoted as follows: Rough lumber, per M, \$12; best quality dressed lumber, per M, \$20; second quality dressed lumber, per M, \$17.50; laths, per M, \$2.50; shingles, per M, \$2.50; with a liberal discount for cash.

UNITED STATES.

Briefly summarized reports from the more important lumber centres tell of increased activity in trade over the preceding month, and a hopeful outlook for the fall. One can hardly say more than this. The good things that we have all been expecting have yet to come; they seem nearer than for some months; the spurt trade has taken augurs an increased activity of movement ahead; but it is still to the future we are looking for actual results. The lumber manufacturers of the Northwest held a meeting at Minneapolis on the 1st inst., in which they decided to take action towards advancing the price of lumber. Over 60 were present from Minnesota, Iowa and Wisconsin. It is proposed to advance prices about a dollar a thousand. This disposition to stiffen up on prices is noticeable at other points and in better goods which are none too plentiful any where we may expect this tendency to prevail. At no point perhaps has a revival foreshadowing better things, been more observable than in the Saginaw Valley. Unsold stocks had been accumulating the season through, but a reference to our report from this section will show a movement now running up into considerable figures. Bulk stocks are quite dronish on Lake Michigan. Short pine stuff has been on the decline, caused by the condition of the stocks which are wanting in usable length and sizes. But taken altogether the lumbermen of the United States have cause to take heart and carry a cheerful mood.

FOREIGN.

Activity has not been a characteristic of the British market of late. Various causes have led to this dullness, not the least of which, so far as the big city of London is concerned, has been the carpenters' strike, which has proven a long drawn out affair, and still continues with prospects of settlement far off. Unfavorable weather has had full swing here, and this has affected all out-door building operations. "But the easy rates ruling for money," says Denny, Mott and Dickson in their usual reliable monthly report, "and the more wholesome position of the trade in respect to credit, (the result of the clearance of unsound firms in the earlier half of the year,) may fairly be expected to operate in favour of elasticity of reaction to sound business and more remunerative prices as soon as these temporary causes of depression have passed away; and we are

inclined to forecast a brisk condition of business in general during the closing months of the year." Whitewood logs are a drug in Liverpool, the market being swamped according to the *London Timber Trade's Journal* with large arrivals from America. Under this pressure prices have gone down to a point about as low as ever known. The Association of Swedish and Norwegian Wood-pulp Manufacturers has now concluded an agreement respecting the output in 1892, reducing it to two-thirds of the ordinary quantity, and, in accordance with the decision of manufacturers last May, the prices for next year are 36kr. per ton, 50 per cent. wet white spruce pulp, 80 kr. for dry f.o.b. Scandinavian port; other kinds in proportion.

Toronto, Ont.

TORONTO, Sept. 30, 1891.

CAR OR CARGO LOTS.

1 & 1 1/2 in. Cut up and better	32 00	33 00
1x10 & 12 dressing and better	18 00	20 00
1x10 & 12 mill run	13 00	14 00
1x10 & 12 dressing	14 00	15 00
1x10 & 12 common	12 00	13 00
1x10 & 12 spruce culls	10 00	11 00
1x10 & 12 mill culls	9 00	
1 inch clear and picks	24 00	25 00
1 inch dressing and better	18 00	20 00
1 inch siding mill run	14 00	15 00
1 inch siding common	11 00	12 00
1 inch siding ship culls	10 00	11 00
1 inch siding mill culls	8 00	9 00
Cull scantling	8 00	9 00
1/2 and thicker cutting up plank	22 00	25 00
1 inch strips 4 in to 8 in mill run	14 00	15 00
1 inch strips, common	11 00	12 00
1 1/2 inch flooring	14 00	15 00
1 1/2 inch flooring	14 00	15 00
XXX shingles, 16 in.	2 30	2 40
XX shingles, 16 in.	1 30	1 40
Lath, No. 1	1 70	1 90
No. 2		1 70

YARD QUOTATIONS.

Mill cull boards & scantling	10 00	Dressing stocks	16 00@20 00
Shipping cull boards, pro-		Picks Am. inspection	30 00
miscuous widths	13 00		
stocks	14 00		
Scantling & joist, up to 16 ft	13 50	1 1/2 in. flooring, dres'd	26 00 30 00
" " " 18 ft	15 00	1 1/2 " " rough	18 00 22 00
" " " 20 ft	16 00	1 3/4 " " dres'd F.M.	25 00 28 00
" " " 22 ft	17 00	" " " undrs'd B.M.	15 00 16 00
" " " 24 ft	19 00	" " " dres'd	18 00 20 00
" " " 26 ft	20 00	" " " undres'd	12 00 15 00
" " " 28 ft	22 00	Beaded sheeting, dres-	
" " " 30 ft	24 00	ed	20 00 35 00
" " " 32 ft	27 00	Clapboarding, dres'd	12 00
" " " 34 ft	29 50	XXX sawn shingles	
" " " 36 ft	31 00	per M	2 60 2 70
" " " 38 ft	33 00	Sawn Lath	1 90 2 00
" " " 40 to 44 ft	37 00	Red oak	30 00 40 00
White	37 00	White	37 00 45 00
Cutting up planks 1 and		Basswood, No. 1 & 2	28 00 20 00
thicker dry	25 00 28 00	Cherry, No. 1 & 2	50 00 60 00
board	18 00 24 00	White ash, 1 & 2	24 00 35 00
		Black ash, 1 & 2	20 00 30 00

Ottawa, Ont.

OTTAWA, Sept. 30, 1891.

Pine, 1st qual., per M	\$35 00@40 00	Pine 4th qual. deals	10 00 12 00
" 2nd "	22 00 25 00	" mill culls	8 00 10 00
" shipping culls	14 00 16 00	Laths	1 25 1 50

Montreal, Que.

MONTREAL, Sept. 30, 1891.

Pine, 1st qua'y per M	\$35 00@40 00	Basswood	12 00 20 00
Pine, 2nd "	25 00 28 00	Oak, per M	40 00 60 00
Pine shipping culls		Walnut	60 00 100 00
per M	13 00 16 00	Cherry	60 00 80 00
Pine, 4th quality		Butternut, per M	22 00 40 00
deals per M	10 00 12 00	Birch	15 00 25 00
Pine, mill culls, per M	8 00 10 00	Spruce timber	13 00 16 00
Spruce, per M	6 00 12 00	Hard Maple	20 00 21 00
Hemlock, lumber	8 00 10 00	1 1/2 Lath	1 60 1 90
Hemlock timber	13 00 14 00	Shingles, 1st, per M	3 00
Ash	13 00 25 00	Shingles, 2nd, "	1 25 1 50

St. John, N. B.

ST. JOHN, Sept. 30, 1891.

Deals, Boards, Scantling, etc.		Spruce boards		12 00
Spruce deals	\$12 00	Pine	-12 00@40 00	
Pine	15 00	Oak	- 40 00	
Deal ends	6 00	Ash	-15 00@25 00	
Scantling	10 00	Hemlock	- 7 50	
Shingles.				
Spruce, extra	\$3 50	No. 1	- 1 25	
" clear	- 3 00	Pine	- 1 25	
" No. 1 extra	- 2 25			
Clapboards.				
Pine, extra	- 35 00	Spruce, extra	- 24 00	
" clears	- 45 00	" clears	- 23 00	
" 2d clears	- 35 00	" No. 1	- 15 00	
		" No. 2	- 10 00	
Flooring, Dressed.				
6 in., No. 1	- 12 00	4 in., No. 1	- 12 00	
" No. 2	- 10 00	" No. 2	- 10 00	
Miscellaneous.				
Staves	- 3 00@ 4 50	Laths	- 1 80	
Heading 17 in. per pr.	0 4	Pickets	- 6 50@15 00	
" 18 in.	0 4 1/2	Railway ties		
" 22 in.	0 4 1/2			

New York City

NEW YORK, Sept. 30.—Perhaps the best that can be said of the lumber market here is that it shows some improvement; not much to brag about, but a start. This is also to be noted that whatever increased demand exists is in anticipation of colder weather—stocking up to some extent for the winter. Very little stuff is required for immediate use. Money continues hard to get. We have one advantage over some points—the trade are pretty thoroughly united. There is not that cutting of prices that is too common to some localities. White pine is shaping up an improved market; the



## SAW MILL BUILDING.

BY J. H. MINER.

AN ITEM to be closely considered in erecting any mill, is the timber supply. Few men can look over a tract of timber and not overestimate it. It is bad policy to erect a mill on a small lot of timber, calculating to buy the adjoining timber later. It will in many cases cost two or three times the amount that you could have got an option on it 'at. Better keep quiet and secure plenty of timber if any money is to be made.

Erecting a mill on a stream or water course, is a different thing. Here the location of the mill and opportunities of holding logs in swift water must be closely looked at.

The amount of waste around a saw mill can in many cases be worked up very economically, in a way not known to all. Where lath are not in sufficient demand, all slabs should be worked into box boards or heading, which will command a nice profit at your nearest city. An ordinary shingle machine can be used for this purpose and all trimmings can be utilized. A boy at a small cost will work up the refuse from a mill of 15,000 feet capacity.

The care and assorting of timber should be done but once. Many large mills spend more money to take care of their product than to make it. A good edgerman and assorter are necessary. The latter in ordinary mills may be one of the hands at a salary above the rest. Bad work starts back from the sawyer; where he uses bad judgment in setting and sawing, the edgerman is compelled to spoil more to rectify the carelessness.

Lumber should be well trimmed. Defects never grow smaller. Where judgment is not used, a board may be reduced from clear to a cull for the want of one foot more in trimming, or one inch in edging. When the lumber leaves a mill it should be so graded that there are no rejected pieces and no tearing down a stack to "pick." The policy of putting in a few better boards to compensate for some worse ones, will never work with customers. The natural tendency is toward accuracy. A man wants it as near alike as possible.

By close grading is where many yard dealers make the profit which the mill man should make. The shipments are made without much attention to rigid inspection. The buyer never gives any credit for what is above the inspection, but lays aside the lower grade and culls, that the mill man may come over and see for himself. Green lumber presents a deceiving appearance, and the mill man is surprised at shakes, loose knots, stained sap and the appearance of rot. The considerate, successful merchant classifies his goods. How many customers would be had and what would he make lumping certain articles together? Nothing; yet we see mill men with competition just as sharp working on this plan.

It is safe to count a ten per cent. loss by the time lumber leaves the mill until the money is received in the office, and many mills lose much more than this—not only from rejection because of bad assorting, but from the care and abuse lumber is subjected to in many yards.

## HOW TO BE A SUCCESSFUL SAWYER.

1. Acquire a sufficient knowledge of machinery to keep a mill in good repair.

2. See that both the machinery and saws are in good order.

3. It does not follow because one saw will work well that another will do the same on the same mandrel, or that even two saws will hang alike on the same mandrel. On the principle that no two clocks can be made that tick alike, no two saws can be made to run alike.

4. It is not well to file all the teeth of circular saws from the same side of the saw, especially if each alternate tooth is bent for the set, but file one-half of the teeth from each side of the saw, and of the teeth that are bent from you, so as to leave them on a slight bevel, and the outer corners a little the longest.

5. Never file any saw to too sharp or acute angles under the teeth, but on circular lines, as all saws are liable to crack from sharp corners.

6. Keep your saw round, so that each tooth will do

its proportional part of the work; if a reciprocating saw, keep the cutting points jointed on a straight line.

7. The teeth of all saws wear narrowest at the extreme point; consequently they must be kept spread so that they will be widest at the very points of the teeth; otherwise saws will not work successfully.

8. Teeth of all saws should be kept as near a uniform shape as possible, in order to keep a circular saw in balance and condition for business.

9. Frosted steel is always brittle. No intelligent woodsman will use a good chopping ax on hard frozen timber until he has taken the frost out of it, and no intelligent sawyer ought to attempt to set the teeth of any saw without taking out the frost, if there is frost in it.

## AMERICAN LUMBERMEN IN CANADA.

A RECORD OF SOME RECENT OPERATIONS.

G. A. BURTON, representing the Pulp Wood Supply Company, of Appleton, Wis., spent some time during September in the Algoma district with a view to making an arrangement with a responsible party for the taking out of some twenty thousands cords of paper wood.

H. M. Sage and Hiram Emery of Bay City, Mich., have purchased a timber limit on the Serpent river, and Mr. Emery has started camp with the intention of putting in 20,000,000 feet of logs, which will be towed to the Sage mill in Michigan. Without this supply the Sage mill was likely to have been closed down.

A. J. Scott and Eli McLaughlin, of Michigan are in the Georgian Bay section looking up timber limits for William Peter to stock his mill at Bay City, Mich.

An American lumber exchange gives currency to the rumor that Merrill & Ring, of Saginaw, Mich., are talking of turning over their mills at Parry Sound, Ont., to some other operators.

Edmund Hall, of Michigan has parties prospecting for timber berths, in the Georgian Bay territories.

A consignment of 306,685 feet of pine lumber from Byng Inlet, Ont., reached Bay City, Mich., per barge *Hercules* on 8th ult. There is said to be no previous record of the arrival at this port of a direct consignment of lumber from Canada.

Howry Bros., of Saginaw, Mich., shipped on 7th ult., from White Fish river, a raft of 3,500,000 feet of logs, and will take another over immediately on her return.

Nelson Holland of Michigan is a large buyer of Canadian logs.

The Saginaw Lumber and Salt Company depends almost wholly upon Canada for its supply of logs. The company owning a large body of timber on the Vermillion and Wahnapiatae rivers, and also on Fitzwilliam island.

## A BOOK FOR LUMBERMEN.

A VERY complete directory of lumbermen in Canada and the United States has just been issued by Rand, McNally & Co., of Chicago. The work contains the names of lumbermen, loggers, sash and door men—in truth of every one identified with the lumber trade. The financial rating of each firm, so far as it has been possible to cover the ground, is also given. The work besides contains much valuable information concerning the grading and inspection of lumber, legal pointers for lumbermen, and the power, style and daily capacity of the different mills in these territories. The work makes one large volume of nearly 700 pages, and the name of the veteran publishers is a guarantee of the excellent mechanical make-up of the book.

## BITS OF LUMBER.

Shipments of lumber from San Francisco to South America for the first six months of 1891 fell short of those of the first six months of 1890 by over 5,000,000 feet.

More than 300,000 persons are occupied to-day in the United States in the direct manufacture of forest and saw mill products alone.

Rosewood takes its name not so much from its color as its fragrance when first cut. It still remains prince among the finer woods, being worth \$750 per 1,000 feet board measure.



When a belt breaks from a fair strain, it bursts nearly straight across at the weakest part. When a belt is broken diagonally across the solid leather, then be sure it is torn by something else than fair strain.

An expert in such matters says he has found the following the best thing he has tried for making joints against fluid pressure: Five pounds of paris white, five pounds of red lead, four pounds black oxide manganese. The whole is to be well mixed, and a little asbestos and boiled oil added. This, he says, soon becomes nearly as hard as the iron itself.

It is considered a good load for a belt to be able to manage fifty pounds for every inch in width; in fact this is considered about as much as a belt is able to stand, for seventy-five pounds for every inch in width to let the slack side run with only one third this strain, for it is the difference in tension that does the business in belt driving.

If you wish to prevent the slipping of pulleys, throw out your iron pulleys and put in wooden ones, or else cover the iron ones with leather or wood. High speed light belts should be fastened together with the strongest quality of bed ticking, torn into strips one inch wide and double lace into the belt. It will last longer than the best rawhide lacing, and when it breaks will give away all along and not tear out the holes in the belt. Those who do not believe this, just try it for any belt under eight inches in width.

A traveller has recently returned from Mexico with an idea which he hopes to utilize in the manufacture of flour. He notes that for centuries the Mexicans have been accustomed to parch their grain before grinding it, and claims to have discovered that the heat gives the flour a sweetness and fragrance unknown in the flour of ordinary brands, and at the same time adds much to its power of nutrition. Mills are to be equipped with apparatus for parching the wheat before putting it in the hopper.

One of the latest applications of electricity is to lumbering and a company has been formed for the purpose of exploiting a lumber carrier to be electrically worked. The apparatus consists simply of a clamp to be swung from trees or other supports on which hangs a cable; the cable is drawn taut, and on it run pulleys from which hangs the chains which carry the logs about three feet from the ground.

One very important cause of deterioration in boilers is due to the fact of their becoming too small to do the work without forcing, so that the pulsations of the engine cause a well marked succession of shocks on the boiler, which result in the weakening of the material. By placing one's hand on the head or shell of the boiler, the vibrations of the metal can be felt similar to the rising and falling of a man's chest while breathing.

To make elevator-cups discharge perfectly the speed of belt and size of pulley should be as follows: Of belt speed 200 to 250 feet per minute, size of pulley 24 inches; speed 300 to 350 feet, pulley 36 inches; speed 400 to 450 feet, pulley 48 inches; speed 500 to 550 feet, pulley 60 inches, and speed 600 to 650 feet, pulley 72 inches; or 35 to 40 revolutions per minute of any size pulley.

An excellent way to discover the whereabouts of pound about an engine is to place the end of a piece of rubber hose to one ear and the other at different parts of the engine. Sometimes it may be necessary to stop up the other ear, as sound travels in a very deceptive way. Some engineers put the end of a thin pine stick between the teeth, and let the other end touch the suspected part of the engine. We have always found the hose quicker and more reliable.

A shaft that is crooked, and is run in bearings that are in line, consumes power equal to the amount of strain it requires to spring it into line, and this strain is constant in any position that the shaft may be in, but as it revolves it shifts the strain to the bearings, and has a tendency to wear and loosen it. If the shaft is straight, and the bearings are out of line or level, the result is similar as to the constant strain of bending the shaft as it revolves, but the strain on the bearing will be one way all the time, and the tendency will be to wear the bearing in a direction that will allow the shaft to straighten itself. If the shaft is crooked and the bearings are out of line to the same amount, there will be one point in each revolution where there will be no strain, but opposite to that will be a point where it will be double, and the result will be a jerky motion, worse than if one or the other was right.



**THE CROWN LANDS OF NEW BRUNSWICK.**

By EDWARD JACK, C. E.

THE position of the crown timber lands of this Province is none too encouraging to the lumbermen. Years ago the lumbermen were given leases for a period of ten years; the stumpage payable under such leases was \$1.25 a thousand. Many of them had been purchased at large sums over and above the upset price of \$8 a mile, very conclusive evidence that the rate of stumpage, \$1.25 a thousand, was not too high. Owing to some trouble with the representatives of the city and county of St. John, the local government finding that they could not stand without the aid of money, resorted to the unheard-of and extraordinary measure of rebating to those who had contracted to pay this sum of \$1.25 a thousand, a fifth part thereof, or in other words the sum of 25 cents a thousand, thus virtually canceling the solemn agreements which the lumbermen had made to pay a certain and specific sum of money. They did not cancel the whole agreement and offer the lands at sale again by public auction subject to this lower rate of stumpage, for the simple reason that it did not suit these lumbermen whose representatives desired to make the corrupt bargain above referred to, because there were outsiders who stood ready to buy these leases and to pay large bonus for them. This bonus had been lost, thus entailing a double loss on the unfortunate country, first, that of the 25 cents a thousand, and second, that of the bonus for the unexpired term of ten years. This bonus might have been safely estimated at \$50,000. This statement will explain fully enough the inwardness of the famous or rather the infamous Northumberland deal. Now what is the present state of matters? The ten years lease will expire in a year or two; they will be renewed to the present lease holders, or will they be offered again for sale by public auction? What is the government policy? since, until this is known, capital from the United States cannot be introduced into New Brunswick to forward any extensive wood manufacturing enterprises which will have to depend for their source of supply upon timber lands which are not the property of the crown. The writer has always looked unfavorably on the annual or even decennial sale of

timber berths at Fredericton, and believes that the parties who have bought their timber leases at public auction should be allowed to hold them so long as they comply with the conditions therein contained, since it is no difference to the country who holds these leases so long as the stumpage is paid and conditions performed; in fact if one would be willing to pay the mileage on the land and not cut the lumber, but hold the same until there should be a greater demand, he would be doing the country a great service for holding and caring for the timber, and would also be aiding to curtail the cut of lumber for spruce in this province, which is not excessive. There is a large amount of capital in the United States which can be introduced into New Brunswick, to be used in the manufacture of woods in various shapes, so soon as the government will adopt such a policy as will give some security that the leases of crown land which may have been purchased shall not be subject to be taken away at the expiration of a short period and again offered for sale. There is in New Brunswick a vast area of crown land not now under lease; much of this would rapidly be taken up did the government give leases renewable yearly, so long as the conditions contained in them are being complied with, and the revenue from the crown timber lands would thus be greatly increased.

FREDRICKTON, N.B.

**A USEFUL CATALOGUE.**

We are in receipt of a 66 page catalogue of new and second-hand machinery from H. W. Petrie the well-known dealer, whose large ware-rooms are located on Front street. There is hardly anything in the way of machinery that Mr. Petrie has not for sale. The list includes machine tools, chucks, boring machines, drill presses, drills, milling machines, power hammers, punch and shearing machines, bending rolls, tops and dies, screw plates, bolt cutters, jack screws, machinists' stocks and dies, forges, anvils, vises, saw gummers, engines and boilers, feed pumps, injectors, tube brushes, governors, pressure gauges, steam pumps, steam fire engines, wood-working machinery, sand papering machinery, circular saws, belting, hose, lace leather, belt

fasteners, water and steam gristmill machinery, mill making machinery, cotton and wool machinery, agricultural machinery, etc. To all interested in Petrie's depot is well worth a visit

**TO THE WEST! TO THE WEST!**

TO THE West! to the West! to the land of the free.  
Where mighty St. Lawrence rolls down to the sea,  
Where a man is a man, if he's willing to go,  
And the humblest may gather the fruits of the soil;  
Where children are blessings, and he who hath most,  
Hath aid for his fortune and riches to boast;  
Where the young may exult, and the aged may rest,  
Away, far away, to the Land of the West!  
To the West! to the West! where the rivers that flow,  
Run thousands of miles, spreading out as they go;  
Where the green waving forests, that echo our call,  
Are wide as old England, and free to us all;  
Where the prairies, like seas where the billows have rolled,  
Are broad as the kingdoms and empires of old;  
And the lakes are like oceans in storm or in rest,  
Away, far away, to the Land of the West.  
To the West! to the West! there is wealth to be won,  
The forest to clear is the work to be done,  
We'll try it, we'll do it, and never despair,  
While there's light in the sunshine and breath in the air,  
The bold Independence that labor will buy,  
Shall strengthen our hands and forbid us to sigh,  
Away! far away! let us hope for the best,  
And build up a new home in the land of the West!

**FOR SALE—A RARE CHANCE.**

A VERY desirable mill property in the town of Essex, Ont., known as the Hanlan Mills, for the manufacture of staves and lumber. The daily capacity of 20,000 feet of lumber and 34,000 staves. Twelve acres of land for mill yard, on which is located 4 charcoal kilns, 1 boarding house, two tenant houses, barns, sheds and other outbuildings, with an unlimited supply of pure well water; with or without horses, trucks, waggons, etc. Also six million feet of standing timber, one-half elm; balance oak, cottonwood, ash, maple and sycamore; from one to three miles from the mill; and other timber in easy reach can be bought. The mills are on the line of Michigan Central Railway, with two spurs running into the mill yard, and within fifteen miles from Detroit. Terms liberal. Good reasons given for selling. Write or call on the proprietor, T. H. DECEW, Essex, Ont.

**WANTED AND FOR SALE.**

Advertisements will be inserted in this department at the rate of 15 cents per line each insertion. When four or more consecutive insertions are ordered a discount of 25 per cent. will be allowed. This notice shows the width of the line, and is set in Nonpareil type. Advertisements must be received not later than the 25th of each month to insure insertion in the following issue.

**WANTED AT ONCE**—delivered at Toronto Junction, from \$5,000 to \$10,000 worth of lumber for building and manufacturing purposes for fully paid up stock in a flourishing manufacturing business, well established; a continuous supply of over 2,000,000 feet required annually. The Gurd Brandon Woodenware Co., Limited, Toronto Junction, Ont.

**PARTNERSHIP WANTED** in Sawmill, Sash and Door or Furniture Factory, or any other class of good wood-working establishment. Advertiser will invest \$5,000 cash. Address, "PARTNER" care of CANADA LUMBERMAN.

**HARDWOOD** lumber, bought, sold or received on consignment, TUCKER DAVID, lumber commission merchant, 202 Eleventh Ave., N.Y.

**SAW AND SHINGLE MILL**

**FOR SALE**—on the Manitoulin, near Little Current. A bargain. Address, W. L. H., CANADA LUMBERMAN.

**SHINGLE LIMIT WANTED.**

**WANTED**—Good shingle timber limit. Address, P. J. D., care CANADA LUMBERMAN.

**PARTNER WANTED.**

**WANTED**—Partner—Silent or active, with \$10,000 to \$15,000, to handle lumber 1892. Address, T. C. F., care CANADA LUMBERMAN.

**STEEL RAILS, ETC.**

**SEVERAL** thousand feet T rails 12 and 20 lbs. to the yd. A large quantity of flat strap rail for tramways. 20 pair wheels and axles, all in good second hand condition, very cheap.

JOHN J. GARTSHORE,

49 Front Street, West, Toronto.

**FOR SALE, RENT OR PARTNERSHIP**

**FIRST CLASS** saw mill, planing mill, sash and door factory and dry kiln, 35 pieces of machinery in complete running order, situated just outside of limits of city of Kingston. Premises suitable for a ship yard, or will sell machinery, dry kiln or building for removal. For particulars and catalogue of machinery address M. STRACHAN & SON, Kingston, Ont.

**WANTED—TO BUY.**

**GOOD** Canadian Timber Limits and Georgian Bay saw logs. Address, BEN BIRDSALL, Whitney Building, Detroit, Mich.

**SALE OF TIMBER LIMITS.**

For sale by Public Auction, at the Russel House, Ottawa, at three o'clock in the afternoon of TUESDAY 26th October, 1891, the following Timber Limits.

Parcel No. 1—Kippewa Birth No. 21, on White Pine River, area 22 square miles, being one of the few Virgin Forests and contains a considerable quantity of superior Pine with very short haul.

Parcel No. 2—Berths A & B River Coulonge, area 100 square miles. This country is very nearly all green and contains a large quantity of good Pine, short haul, the drive from which reaches the Ottawa early in June.

With Parcel No. 2, there are supplies and plant for one chantier, to be taken at a valuation as per inventory.

The terms and conditions made known on day of sale.

For other information, apply to, R. GOKMAN, or I. B. TACKABERRY, Auctioneer.

Ottawa, Sept. 16th, 1891.

**GOOD BUSINESS CHANGE**

A party having the disposal of about 50,000,000 feet of good standing White Pine under Government license, besides a vast quantity of standing Hemlock, Spruce, Birch, &c., in a most convenient part of the District of Muskoka, together with a good Mill, nearly new, containing the very best machinery, is anxious to meet with a purchaser or parties willing to form a joint stock company. The whole property will be put in at an extra good bargain, and employment arranged for practical men. Full particulars as to Limits, Mill and prices, map, &c., can be seen at the office of the "Canada Lumberman."

**WANTED**

**SAW MILLS**

**IN - LITTLE - BELT**

—AND—

**ROCKY MOUNTAINS**

ALONG LINE OF

**Great Northern Railway**

For particulars write

**J. M. SUCKINS,**

4 Palmer House Block, Toronto

Or F. J. WHITNEY, Gen. Pass. Agent, St. Paul, Minn.

**PLANING MILL FOR SALE.**

A Planing Mill and Sash and Door Factory in running order and fully stocked with best machines. Land freehold. **GOOD LOCATION IN TORONTO. WILL BE SOLD AT A BARGAIN ON EASY TERMS.**

Apply to "Planing Mill"

Canada Lumberman.

**Muskoka and Georgian Bay Navigation Company.**

**Muskoka Division.**

For all ports upon Lake Muskoka, Rosseau and Joseph, close connections are made daily at Muskoka wharf with mail and express trains of G.T.R. from Toronto and Hamilton as under.

On Mondays, Wednesdays and Fridays at 7.15 a.m. the Muskoka leaves for Rosseau and intermediate places, and at 1.45 p.m. the "Nipissing" and "Kenozha" leave for all points on the three lakes.

On Tuesdays, Thursdays and Saturdays the "Muskoka" leaves at 7.15 a.m. for Port Cockburn and intermediate places, and at 2.45 p.m. the "Nipissing" and "Kenozha" leave for all points on the three lakes.

**Georgian Bay Division.**

The Str. "Manitou" leaves Parry Sound daily at 7 a.m., calling at Midland on Tuesdays and Fridays and at Penetanguishene on Mondays, Wednesdays, Thursdays and Saturdays. Returning she leaves Midland for Parry Sound on arrival of mail train at 1.42 p.m. on Tuesdays and Fridays, and Penetanguishene for Parry Sound on arrival of mail train at 12.45 p.m. on Mondays, Wednesdays, Thursdays and Saturdays.

The "Manitou" is the only daily boat to Parry Sound and the only boat running the famous South Channel among the islands where the best of fishing is to be had.

**Magnetawan Division.**

The "Wenonah" leaves Burk's Falls daily at 7 a.m. for Magnetawan, Abmic Harbor and intermediate ports, returning arrives at Burk's Falls at about 5 p.m.

**Good Fishing—Safe Boating and Bathing.**

Full information from any G.T.R. agent. Send for folders with map and full information as to rates &c.

J. S. Playfair, A. P. Cockburn, President, Toronto, Gen. Mgr. Gravenhurst, J. A. Link, Sec.-Treas., Gravenhurst.

For information respecting the Georgian Bay Division apply to J. Wilkinson, Purser "Manitou," Penetanguishene P.O.

**WILLIAM FOSTER**

**Lumber & Commission Merchant**

Receiver and forwarder of

**LUMBER, LATH & SHINGLES**

Correspondence Solicited.

**OWEN SOUND, ONT.**

*Repairing*  
*Promptly and*  
*Carefully*  
*Executed*

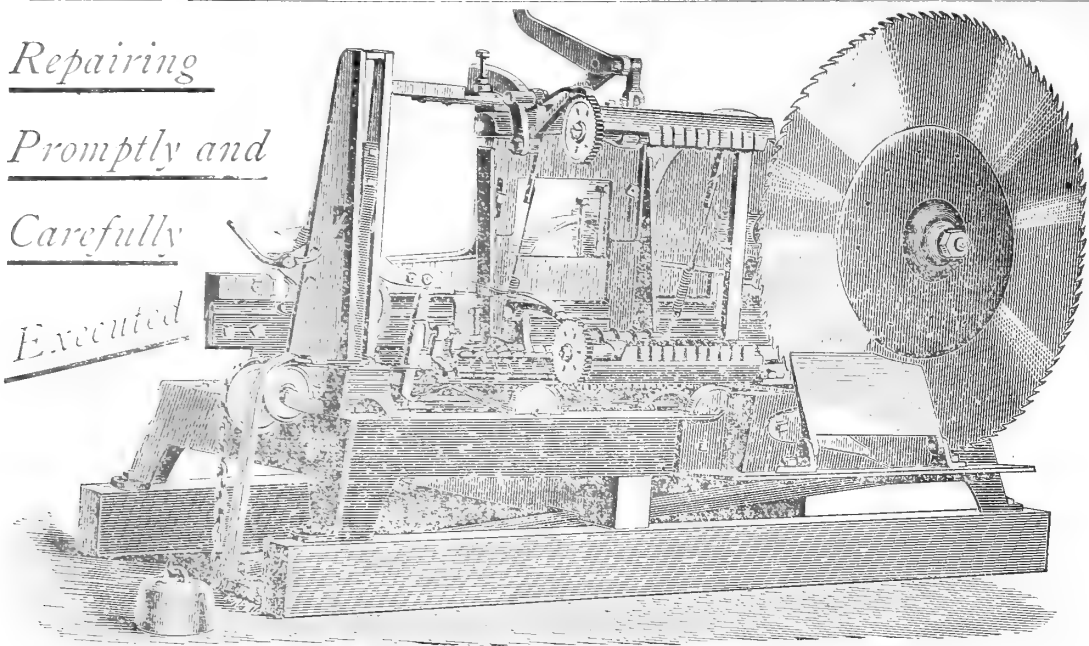

**B. R. MOWRY & SON**

MANUFACTURERS OF

**Saw Mill  
and Shingle Mill  
Machinery.**

*Shingle Machinery a Specialty.*

**The "BOSS" SHINGLE MACHINE**

Manufactured by us is acknowledged by practical men to be the best machine in the market.

GRAVENHURST, ONT.

# The \*XXX\* Saw \*Gummer\* and \*Sharpener

**HAS NO RIVAL**

**For Variety, Capacity or Quality of Work.**

OR FOR

**Simplicity, Durability, Cheapness.**

Will take saws from 6 inches to 6 feet diameter, sets the saw forward one tooth at a time automatically. Sharpens any saw (rip or cross-cut) perfectly. Giving the teeth any desired pitch or bevel, and making all the teeth exactly alike. Will sharpen 20 teeth in ordinary mill saw in One Minute, or 100 teeth in shingle saw in four or five minutes. The cut shows outline of mill saw 54 inch dia. Patent applied for.

GILMOUR & Co.

Lumber Manufacturers and Dealers.  
F. J. DRAKE Esq, Belleville, (nt).

Trenton, Ont., 26th Aug., 1891.

Dear Sir,—Your Patent Saw Sharpener is giving us good satisfaction. We average about one hundred thousand shingles per day, and sharpen the saws for both automatic and hand-feed machines with your Sharpener. As it keeps the teeth all perfectly uniform it must be easier on the machine and sawyer too. It causes also a great saving in files. We now only use about one 10 in. file per week. Before putting in your machine we used about six per week. As regards your Improved "XXX" Shingle Packer—they work first rate, and are the only machines we could get that would press tight enough. We consider them the best we ever had.

Yours truly,

GILMOUR & CO.

MANUFACTURED ONLY BY

**F. J. DRAKE**

**Belleville, Ontario.**

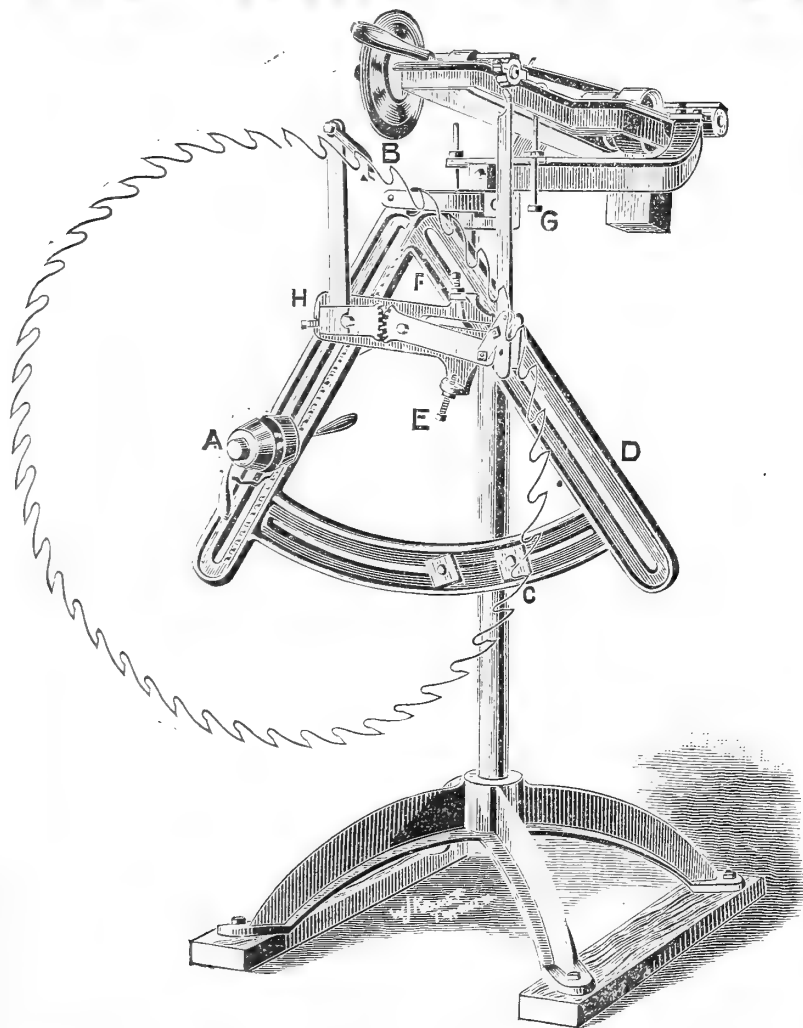

## THE STURTEVANT PATENT PROGRESSIVE LUMBER DRY-KILN.

DRIES HARD AND SOFT WOOD LUMBER WITHOUT WARPING, CHECKING OR BLUING.

The Sturtevant  
System of  
**HEATING**  
Mills  
and Factories  
BOSTON,  
34 OLIVER STREET.  
NEW YORK,  
91 LIBERTY STREET.

Write for Catalogues.

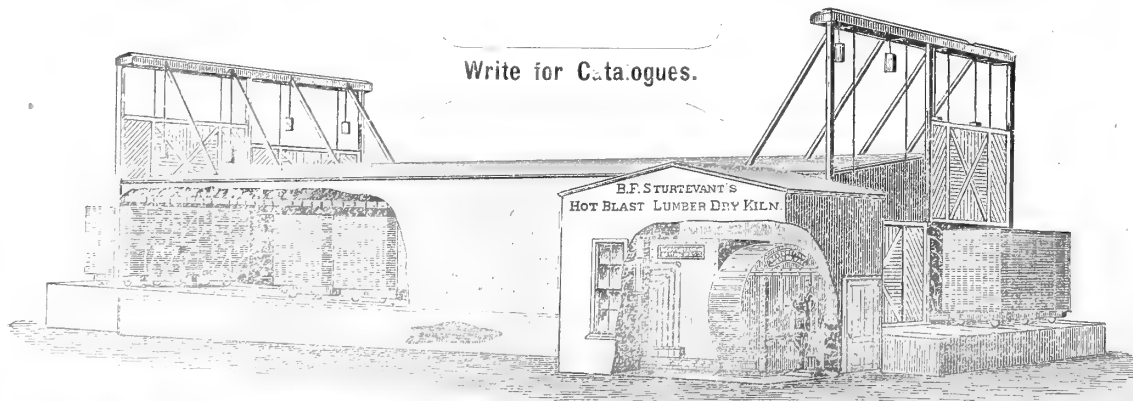

Steel Plate Plan-  
ing Mill  
**Exhausters**  
FOR REMOVING  
Chips, Shavings and  
Sawdust.  
CHICAGO,  
16 South Canal Street,  
PHILADELPHIA,  
185 North Third Street.

**B. F. STURTEVANT CO., BOSTON, MASS., U.S.A.**

A. R. WILLIAMS, Soho Machine Works, Toronto  
GENERAL AGENT FOR THE DOMINION.

# H. W. PETRIE, Machinest and General Machine Dealer

ESTABLISHED 1876.

Main Office, Yard, Storehouse and Shipping Depot, Opp. Union Passenger Station, Toronto, Canada.

\* 141-145 FRONT ST., WEST. \*

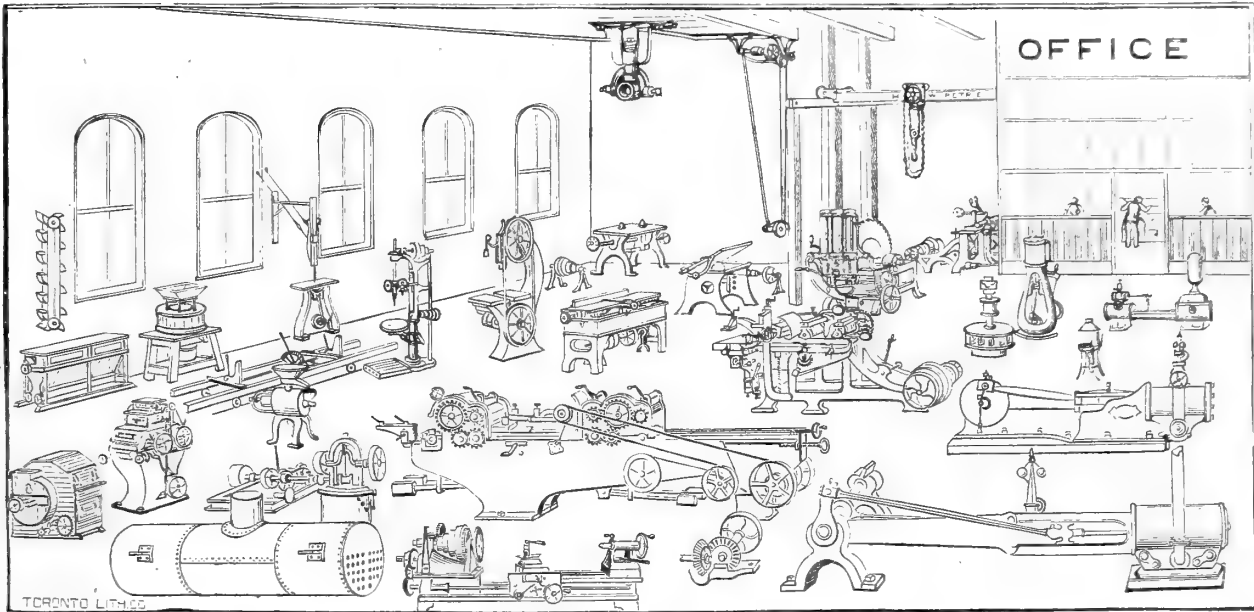

Send for

One of My

New

Catalogues

FREE.

New

66 Page

Descriptive

Catalogue

Just Out.

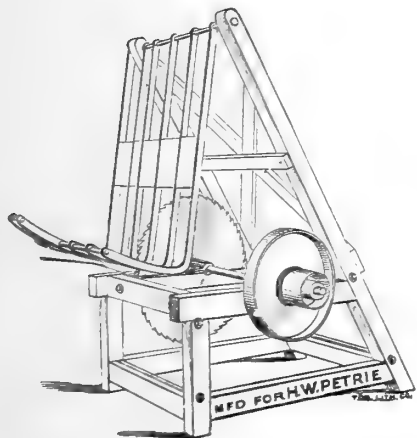

Wood and Shingle Bolt Saw.

## WOOD YARD MACHINERY

:- A Specialty. :-

See New Catalogue No. 16.

The Improved Little Giant Planer, Mather and Moulder.

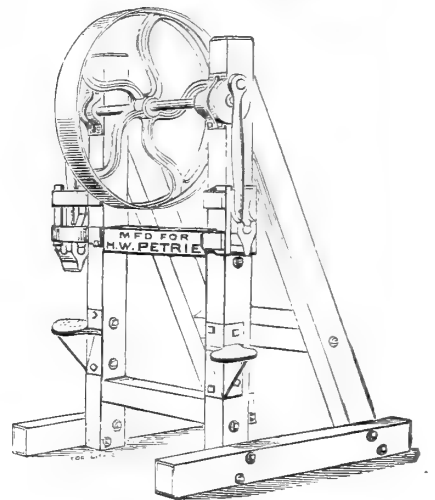

The Champion Wood Splitter.

25,000

CATALOGUES

NOW READY

FOR DISTRIBUTION

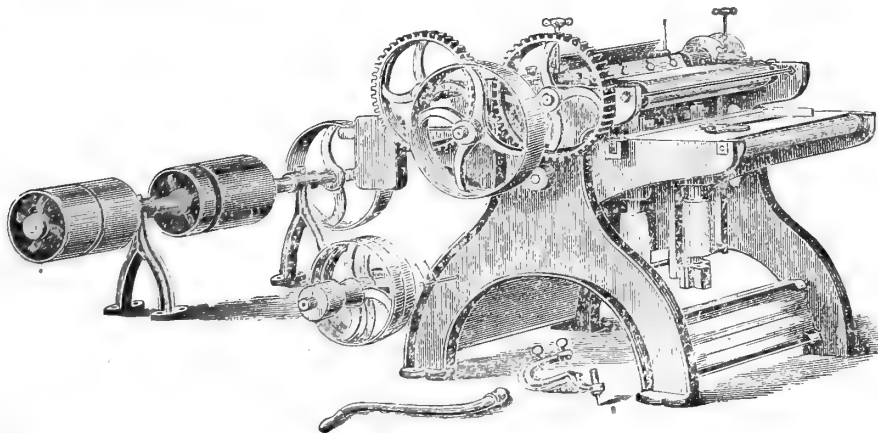

CATALOGUE NO. 16

GIVES FULL

DESCRIPTION

OF ALL

OUR MACHINERY



Planing and Saw Mill Machinery of all Kinds.



CIRCULAR



SAWS.



Cant Dogs, Peavies,  
Skidding Tongs,  
Pike Poles, Coldshuts,  
\* Lumber Bob Sleighs. \*

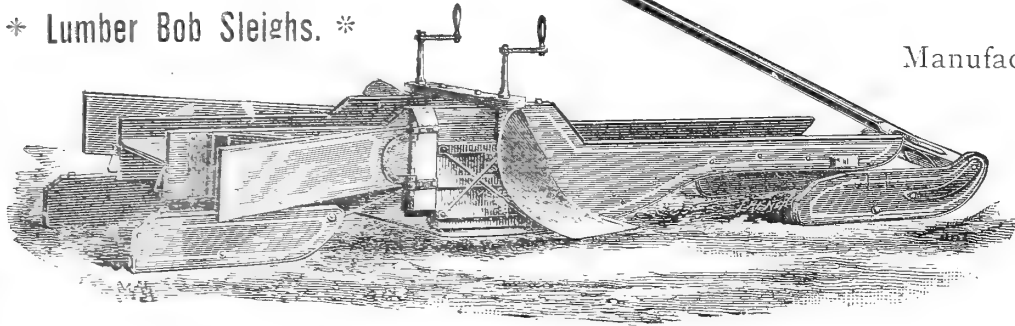

# J. Muckleston & Co.

Kingston, Ont.

Manufacturers of RED TOP LINE

## LUMBERMEN'S \* TOOLS.

And Sole Licences for the Manufacture in the Dominion of  
**BRAZEL'S PAT. SNOW AND SIDEWALK  
PLOWS.**



### Sale

—OF—

## Pine Timber

A QUANTITY of standing pine timber upon unsold and unlicensed lands of the Crown, west of Sudbury, in the neighborhood of the Canadian Pacific Railway, estimated as follows:—

Spanish River.....	13,500,000	feet B. M.
Onaping Lake, north of.....	18,000,000	" "
south of.....	11,000,000	" "
Cat Lake (Ramsay Sta.).....	5,000,000	" "
Township of Moncrieff.....	2,000,000	" "
Hess.....	1,500,000	" "
<b>Total.....</b>	<b>51,000,000</b>	<b>feet B. M.</b>

having been damaged by fire during the past summer, the undersigned hereby calls for tenders for the right to cut the damaged timber. There is also some green pine estimated at 2,000,000 feet in the vicinity south of Onaping Lake, for which tenders are also invited. Tenders will be received up to and including the 15th day of October next, and may be for any parcel or for the whole, and must state the amount per thousand feet board measure the tenderer is willing to pay for the burnt and green timber separately in addition to the regular Crown dues of one dollar per thousand feet board measure. For conditions and further particulars application should be made to the Crown Lands Department.

Mr. John Regan, forest ranger under the Department, will be at Cartier Station on and after the 15th September to give information to parties desirous of examining the timber.

The above figures represent only the Department's estimate, and intending purchasers must satisfy themselves as to quantities, etc.

The Department does not bind itself to accept the highest or any tender.

A. S. HARDY,  
Commissioner of Crown Lands.

1st September, 1891.

No unauthorized advertisement of the above will be paid for.



### FURTHER

## SALE

—OF—

## PINE TIMBER.

A FURTHER quantity of standing pine timber upon unsold Crown Lands north of Sudbury Junction, on the Canadian Pacific Railway, having been damaged by fire, the undersigned hereby calls for tenders for the right to cut the same.

The timber is situated immediately east and north-east of the Township of Lumsden, upon what would be on plan of North Shore and Lake Huron projected Berth 66, and that part of Berth 65 north of Vermilion River.

It is estimated at 32,500,000 feet B. M. viz., thirty million feet B. M. damaged and two and a half million feet B. M. of green pine. Tenders for the whole quantity will be received up to 12 o'clock noon of 31st October next, and must state the amount per thousand feet B. M. or feet cubic the tenderer is willing to pay in excess of the regular Crown dues of \$1 per 1,000 feet B. M. or \$25 per 1,000 feet cubic. For further conditions application should be made to the Crown Lands Department.

Mr. John Cunningham, Forest Ranger at Sudbury will give information to parties desirous of examining the timber.

The above figures represent only the Department's estimate, and intending purchasers must satisfy themselves as to quantities, etc.

The Department does not bind itself to accept the highest or any tender.

A. S. HARDY,  
Commissioner of Crown Lands.

25th September, 1891.

No unauthorized advertisement of the above will be paid for.

## WHEN YOU ARE IN NEED OF PRINTING

You will consult your own interests by sending your order to

## THE CANADA LUMBERMAN JOB DEPT. \*

If you are in need of Stationery for your office, shanties or drives, let us know your wishes and we can guarantee that both our work and prices will please you. Address, The Canada Lumberman Job Dept., Canada Life Building, Toronto, Ont.

### DOLGE PATENT

# Wood \* Split \* Pulleys.

*We guarantee 30 to 60 per cent. more Power with same belt.*

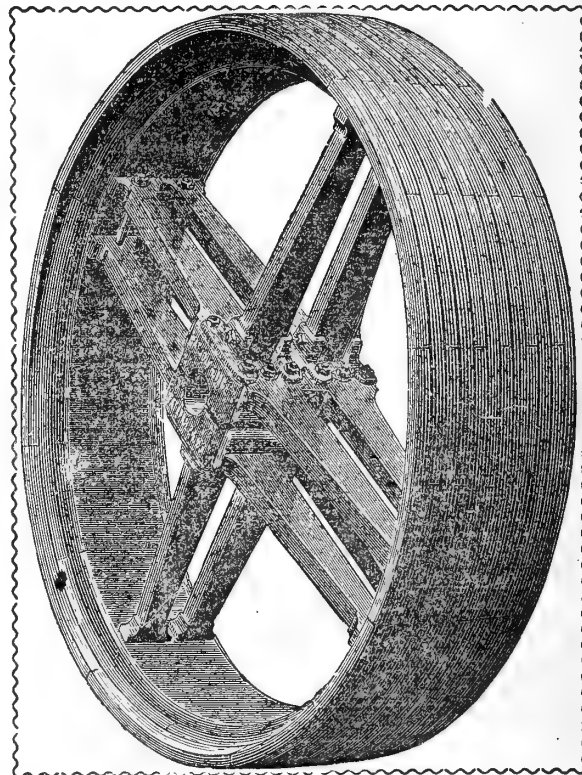

*Every Pulley guaranteed strong enough for Heaviest Mill Work.*

All Sizes in Stock. Send for Catalogue.

**DODGE WOOD SPLIT PULLEY CO.**  
83 King St. West, Toronto.

**Advertising** IN The Canada Lumberman **PAYS**  
**Write for Rates.**

ELECTRIC LIGHT PLANTS

THE THOMSON-HOUSTON AND THOMSON SYSTEMS.

ADDRESS: 58 WELLINGTON ST. MONTREAL, QUE.

FOR MILLS AND FACTORIES.

**A. M. DODGE & CO.**  
**M**ANUFACTURERS of and Wholesale dealers in all kinds of Lumber, Lath and Shingles. Tonawanda, N. Y.

**COWPER & GREGORY.**  
**R**ECEIVERS and Forwarders of Lumber, Lath, Shingles, &c. Unexcelled facilities for shipping by canal or rail. Tonawanda, N. Y.

**CHEESMAN DODGE**  
**T**IMBER and Lumber Merchants. Ship and Boat stock, Railroad Ties, &c. Office, 16 West Seneca Street, Buffalo.

**EMMET FLEMING**  
**I**NSPECTOR and Commission dealer in Lumber. Office, 251 Louisiana Street, Buffalo, N. Y.

**LAYCOCK LUMBER CO.**  
**M**ANUFACTURERS of Pine, Hemlock and Oak Timber up to 85 feet in length. Saw Mills: Ackley, Pa., Black Rock, N. Y., Gravenhurst, Ont. Office, corner Main and Seneca Sts, Buffalo, N. Y.

**J. & T. CHARLTON**  
**W**HOLESALE dealers in Masts and Spars, Canada Round Pine, &c. Tonawanda, N. Y.

**WILLARD W. BROWN.**  
 202 Main Street, Buffalo, handles all kinds of Hard Woods.

**A. P. & W. E. KELLEY CO.**  
**W**HOLESALE Lumber dealers. Yards at Tonawanda and Chicago. Correspondence invited.

**C. P. HAZARD.**  
**W**HOLESALE dealer in Lumber, Shingles, Lath and Fence Posts. Correspondence invited from the Canadian trade. No 92 River Street, Buffalo, N. Y.

**L. A. KELSEY LUMBER CO., (Ltd.)**  
**M**ANUFACTURERS and dealers in Hardwood Lumber of all kinds. Describe stock and write for prices. Office Tonawanda, N. Y.

**BOVEE & HOWDEN**  
**M**ANUFACTURERS and Wholesale dealers in Hard and Soft Wood Lumber. Holders of Canadian stocks are invited to write for quotations. Offices at Tonawanda and Le Roy, N. Y.

**THE TONAWANDA LUMBER CO.**  
**M**ILLS at East Tawas, Mich.; office 106 Main Street, opposite N. Y. C. and H. R. R. Station, North Tonawanda, N. Y.



**LUMBER TRUCK \* WHEELS.**

**The Montreal \***

**\* Car Wheel Co.**

**MANUFACTURERS OF CHARCOAL IRON CHILLED RAILROAD WHEELS**

Offices: New York Life Insurance Building, Montreal.

Works: Lachine, Quebec.

**WE** make a Specialty of Wheels suitable for the requirements of Lumbeimen and Street Car Service, and can supply them Bored, Finished and Balanced.

**CORRESPONDENCE SOLICITED**

**J. J. TURNER,**  
**Sail, Tent and Awning Maker.**  
 251 GEORGE AND 154 KING STREETS, PETERBOROUGH.  
 Canoe, Yacht and Boat Sails made to order. Perfect Fits guaranteed.  
*Every description of Lumbeimen's Subblies and Waterproof Clothing.*

**THE MONARCH BOILER AND HERCULES ENGINE.**

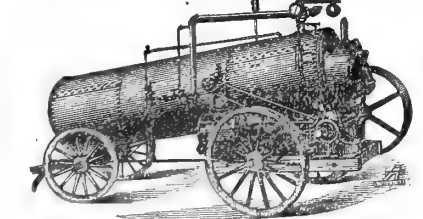

Portable from 6 to 70 horse power. Surpass portable steam power heretofore produced for strength, durability, compactness, and the ease with which they can be moved.  
 The 70 horse power can be taken over the roughest roads, or into the forest, and set up as easily and quickly as an ordinary 20 horse power portable engine, and as firm as a brick-set stationary engine. Engines and boilers of every size and description. Rotary Saw Mills, Shingle and Lath machines, Law Grinders, Planers, etc. Mill machinery and supplies of every description. Every boiler insured against explosion by the Boiler Insurance & Inspection Co. of Canada. Write for circulars.

**A. ROBB & SONS,** Amherst Foundry and Machine works. Amherst, N.S.  
**ESTABLISHED OVER 40 YEARS.**

**PORTER, ROBERTSON & CO.**

STOCKS	WHOLESALE	HARDWOODS
STRIPS	<b>LUMBER</b>	HEMLOCK
SIDINGS		SHINGLES
BILLSTUFF	DEALERS	LATH, ETC.

*Millichamp's Buildings,*  
**35 \* Adelaide \* Street \* East,**  
**TORONTO.**  
 YARD: NORTHERN DOCK, FOOT OF BATHURST STREET.

**FOUR FRICITION GRIP PULLEYS**

**ARE THE ONLY SPLIT GRIP PULLEYS & CUT OFF COUPLINGS MADE. GIVE EVERY SATISFACTION AS DRIVERS OR DRIVEN PULLEYS. FULLY GUARANTEED.**

**WATEROUS ENGINE WORKS CO.**  
 BRANTFORD CANADA

**NAPANEE CEMENT WORKS**

**Hydraulic Cement**

**P**ARTICULARLY adapted for Dams, Smoke Stacks, Foundations, Culverts, Cisterns, Cellars, etc.  
**ENDORSED BY LEADING RAILWAYS AND CONTRACTORS.**  
**ROACH \* LIME,**  
 For Building, Plastering, Gas Purifying, Paper Making, &c.

**THE RATHBUN COMP'Y,**  
**DESERONTO, ONT.,**

**\* TERRA \* COTTA \* FIRE-PROOFING \***

For Use in Old and New Buildings.  
 Endorsed by Leading Architects. Absolutely Fire-proof. About as Cheap as Wood or Brick. Weight One-Third that of Brick. Does not Crack on application of Heat or Water.  
 Deadens Noise. Gives Warmth in Winter; Coolness in Summer.

**Galt \* Machine \* Knife \* Works.**

**MACHINE KNIVES**  
 OF EVERY DESCRIPTION FOR  
**Planing, Moulding & Stave Cutting.**  
 SEND FOR PRICE LIST

**PETER HAY, - - - GALT, ONT**

HERBERT G. ROSS. Box 273. REGINALD C. BLAKER.

**H. G. ROSS & CO.**

*Real Estate, Fire and Life Insurance, Shipping and General Commission Agents.*

**Timber Limits and Farming Lands a Specialty.**

A.B.C. Code, Cable address, "Ross."

**NEW WESTMINSTER, - - - B. C.**

CORRESPONDENCE SOLICITED.

# The Best is the Cheapest

This is True Especially in Machinery.

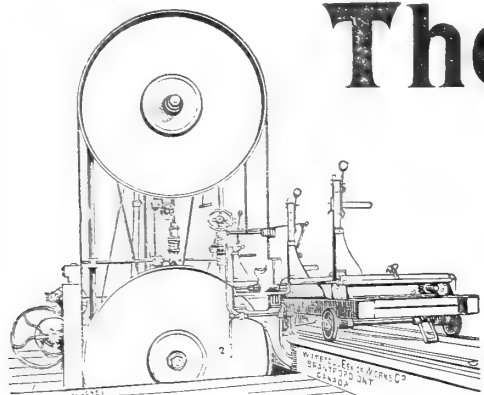

1844

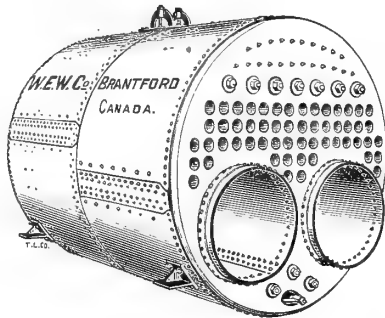

1890

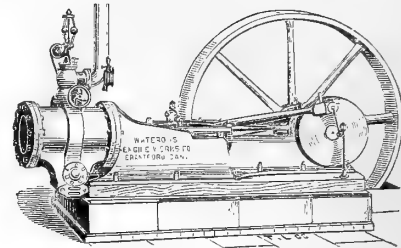

Stationery and Portable Engines.

**OUR SPECIALTY.**

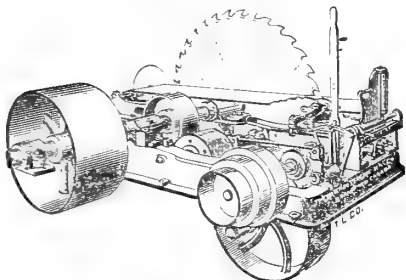

**Saw Mill Machinery**

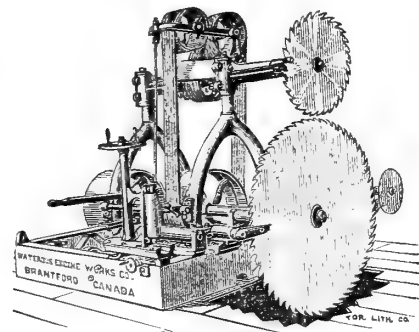
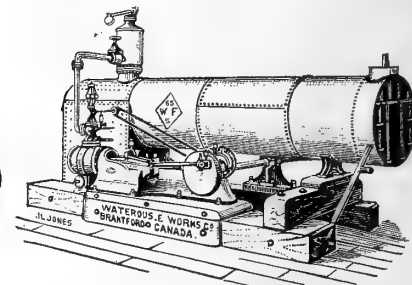
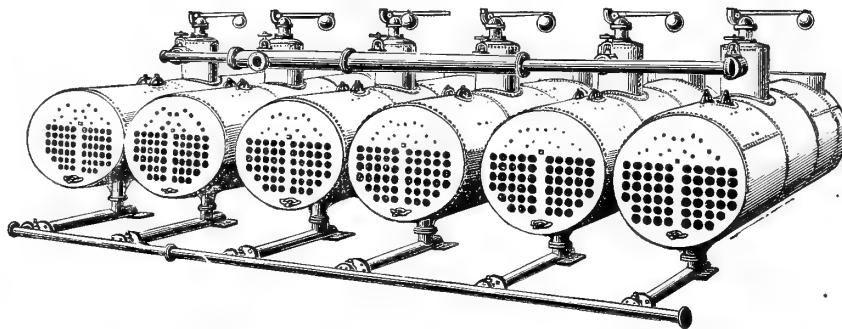

**Band and Circular**

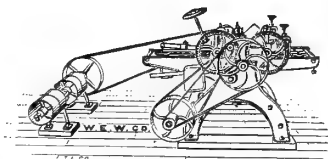

Combined Planer and Matching Machines From \$170 up.

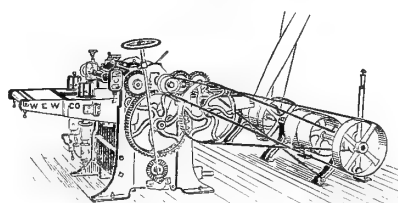

Several Styles of Mill Dogs for Plain and Quarter Sawing.

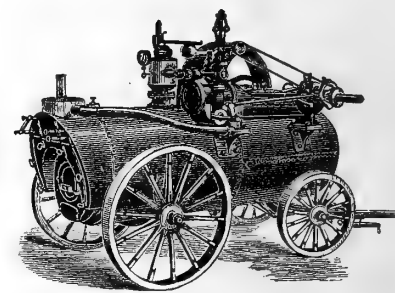

Friction Grip Pulleys.

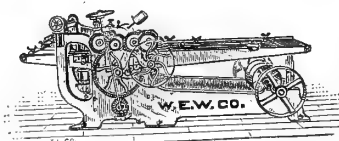

Write for Circulars stating what machinery you require, capacity, &c. Special facilities enable us to quote very low prices.

## WATEROUS Engine Works Co., Limited, Brantford, Canada.

REPRESENTATIVES.

Montreal, A. A. Benson.  
Victoria, B. C., Nichols & Renonts.

Quebec, W. A. Ross  
Toronto, Hugh Cameron.

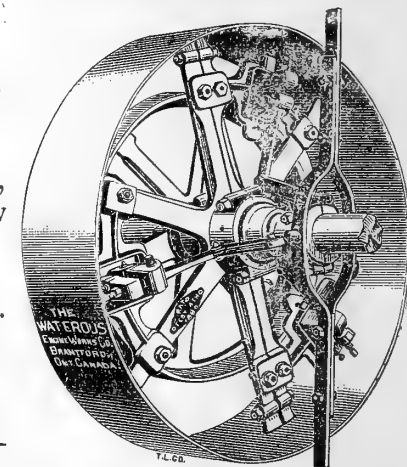

**Turbine Water Wheels and Mining Wheels**

Plain leffel, globe case.

Oscillating Engine, Steam Feed

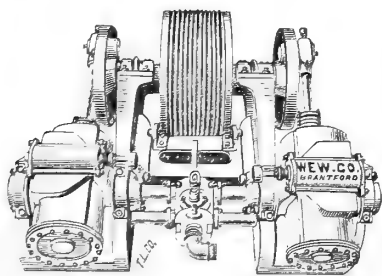

**Gang Edgers**

Heavy, Medium and Light

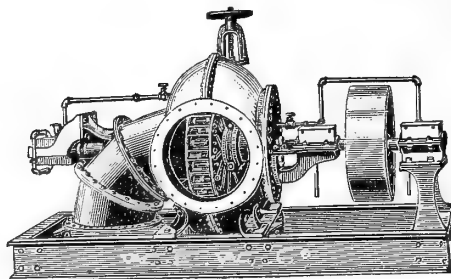
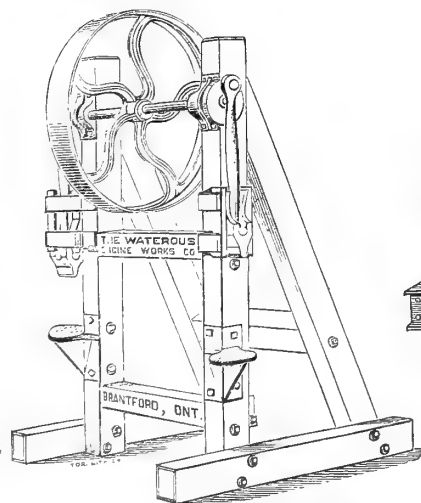

Wood Yard Outfits, Double Axe Splitters and Swing Wood Swans.

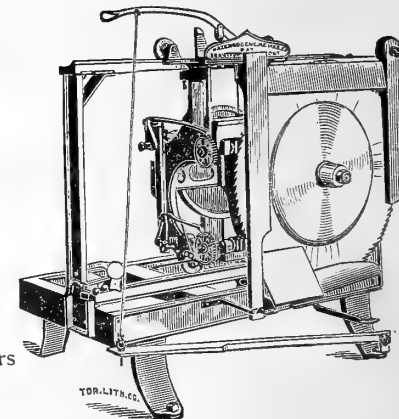

LATH MACHINES.

**Shingle Machines**

Ewart Link Belting, the great Conveying medium.

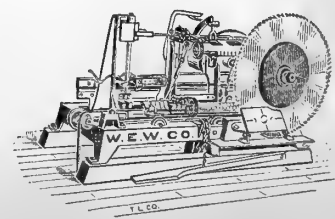
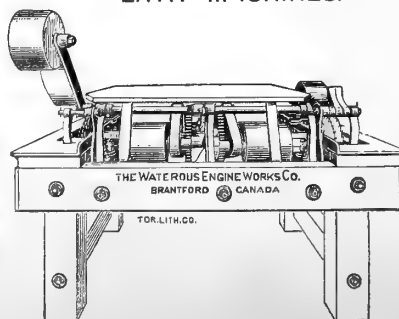
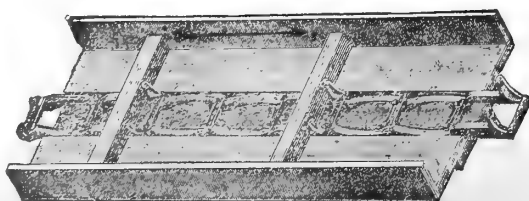



C. C. CLEVELAND. G. F. CLEVELAND.

**J. L. GOODHUE & CO.,**

MANUFACTURERS OF

**Leather Belting**

AND

**Lace Leather.**

DANVILLE - - QUEBEC.

THIS SPACE FOR SALE.

RAILROAD, BANK & OFFICE

**DESKS**

TEES & CO.,

300 ST. JAMES STREET, MONTREAL.

**STORAGE OF LUMBER.**

We are prepared to receive any quantity of Lumber for storage. Freight and money will be advanced on same. Also, Warehouse Receipts issued, which can be hypothecated to banks and others. Storage charges easy. For further particulars apply to

**W. LEAK & CO.**

Lumber, Coal and Wood.

DUNDAS STREET, - - TORONTO.

**GOODDAY, BENSON & CO.**

QUEBEC, P. Q.

**General Lumber & Timber Merchants.**

Correspondence is solicited from parties having choice stocks of Hardwood and Pine to offer, either in the log or in sawn lumber.

**JOHN BERTRAM & SONS,**

CANADA • TOOL • WORKS

DUNDAS, ONTARIO.

MANUFACTURERS OF

**WOOD-WORKING MACHINERY**

MACHINE TOOLS, ETC.

Write for Prices and Catalogues

THIS SPACE FOR SALE.

**GEO. CORMACK**

Wholesale and Retail Dealer in

*All kinds of LUMBER.*

Lumber Shipped to all parts by Rail or Vessel.

WHITBY, - - ONTARIO

**Toronto**

**Lithographing Co.**

LITHOGRAPHERS & ENGRAVERS.

TORONTO.

THOS. WHALEY, President. W. E. HUTCHINSON, Sec.-Treas.

**The Whaley Lumber Co.**

OF HUNTSVILLE, ONT. (LIMITED)

Manufacturers of

**White Pine Lumber, Bill Stuff, Lath and Shingles**

ALSO HARDWOOD LUMBER.

All orders promptly attended to. First-class facilities for shipping.

CORRESPONDENCE SOLICITED.

**Peter Gerlach & Co.**

Manufacturer of



THE ALLIGATOR CHISEL-BIT SAW.

**ALLIGATOR CHISEL-BIT SAWS**

The Champion Stave, Heading and Shingle Machines.

Ice Tools and Mill Supplies.

CLEVELAND, - OHIO.

**J. D. SHIER,**

Manufacturer of

**Lumber, Lath and Shingles**

BRACEBRIDGE, ONT.



ALONZO W. SPOONER

PORT HOPE ONT.

THE HANDSOMEST TOWN IN CANADA AND THE ONLY PLACE IN THE WORLD WHERE COPPERINE IS MADE. HARDWARES ALL SELL IT.

MAKER.

**Investment Bonds.**

**THE DOMINION SAFE DEPOSIT WAREHOUSING & LOAN CO., LTD.**

Head Office—The Canadian Bank of Commerce Building, King St. W., Toronto.

**CAPITAL, ONE MILLION DOLLARS.**

**DIRECTORS.**

W. D. Matthews, Esq., President. Henry W. Darling, Esq., Vice-Pres

John I. Davidson, Esq. S. F. McKinnon, Esq. G. B. Smith, Esq. M.P.P.

H. W. Nelson, Esq. J. P. Clark, Esq. J. H. Starr, Esq.

M. C. Cameron, Esq. Robert Kilgour, Esq. Alexander Nairn, Esq.

Thomas McCracken, Esq. Robert Davies, Esq. Eugene O'Keefe, Esq.

Aaron Ross, Esq.

This Company is now issuing \$100 \$200 \$300, \$400 and \$500 investments in bonds, payable in five, ten and fifteen years from date of issue, with participation in profits, affording all the advantages of compound interest accumulations on small sums of money. These bonds are the obligations of this Company and are specially protected by a sinking fund, invested in first-class real estate mortgages. They are plain definite contracts, subject to no contingencies whatever, are non-forfeitable after one annual payment, with values definitely stated thereon. For a small outlay they secure a fixed and generous return.

To bondholders who complete their contracts the Company guarantee compound interest at the rate of Four Per Cent. Per Annum.

The Company is prepared to receive applications from reliable agents at all points where it is not already represented.

The **Safe Deposit Vaults** of the company cannot be surpassed for absolute security. Call and examine or write for circular **WM. KERR, Manager**

**THE RATHBUN COMPANY,**

DESERONTO, - - ONTARIO,

MANUFACTURERS OF

**Doors, Sash, Blinds, Stairs**

AND ALL KINDS OF WOODEN HOUSE FINISHING MATERIALS.

**CEDAR OIL FOR PURGING BOILERS.**

CORRESPONDENCE SOLICITED

**The American Lumber Yard**

**HAMBURG, GERMANY,**

Offers the best facilities for Yarding and Selling all kinds of

**American Wood Goods**

Address :

ROSENBACHER & CO., BANKERS, Hamburg. CARL GARTNER, Agent, Hamburg.

TAPER TOOTH.

**E. R. Burns**

LANCE TOOTH.



TELEPHONE 5120.

**Saw  
Go.**

TORONTO.



Works at Parkdale.

**WICKES BROS., Saginaw, Mich.**

MANUFACTURERS OF

**GANGS,  
ENGINES  
AND  
BOILERS.**

The accompanying cut represents our new No. 3 Complete Iron Frame Gang Mill especially designed to meet the demand for a smaller type of mill. The strongest and most durable for high speed and thin saws. Write for further particulars.

Southern Agents,  
McARDLE &  
SINCLAIR,  
50 & 52 Barronne St.  
New Orleans, La.

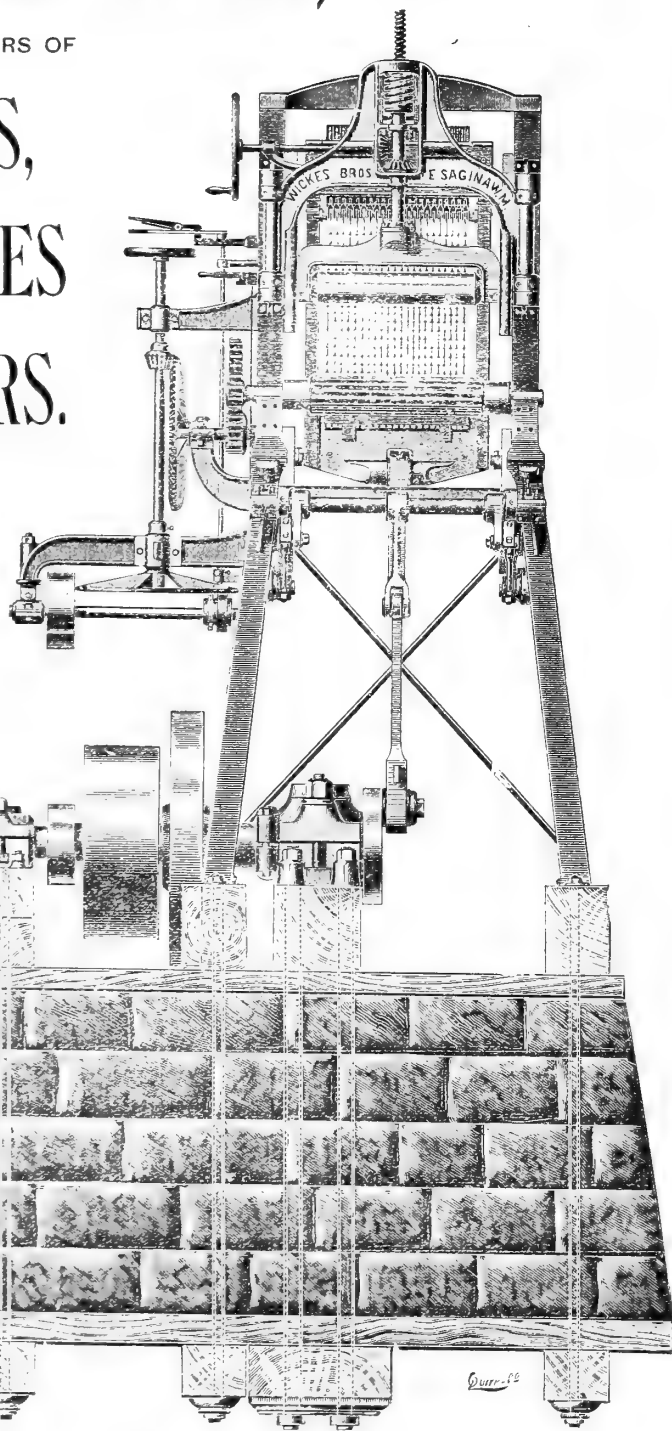

ADVERTISING

IN—  
**THE CANADA LUMBERMAN**  
PAYS.

WRITE FOR RATES.



SCRIBNER'S  
**LUMBER**  
AND  
**LOG BOOK**

Over One Million Sold.

MOST complete book of its kind ever published. Gives measurement of all kinds of Lumber, Logs, Planks, Scantling; cubical contents of square and round Timber; hints to lumber dealers; wood measure; speed of circular saws; care of saws; cord-wood tables; felling trees; growth of trees; land measure; wages, rent, board, interest, stave and heading bolts, etc. Standard book throughout the United States and Canada. Get the new illustrated edition of 1892. Ask your book-seller for it. Send post-paid for 35 cents.

**GEO. W. FISHER,**  
Box 238, Rochester, N. Y.  
or A. G. MORTIMER,  
Toronto, Ontario.

TORONTO AGENCY OF

**The Rathbun Co.**

ARE OPEN TO PURCHASE  
OAK, ASH, BIRCH,  
BASSWOOD  
AND  
GOOD PINE LUMBER  
CEDAR AND PINE  
SHINGLES

Manufacturers having such for sale are invited to communicate with

**T. W. WALKER, Agent**  
**TORONTO**

Office, Cor. Spadina Ave. & Front St.

**ROCHESTER BROS.**  
Commission Agents.

Limits bought and sold on commission. Limits travelled and carefully prepared estimates given. Some first-class berths on the north shore of Lake Huron and on the Upper Ottawa now in our hands for sale. Communications confidential. References given.

36 ROCHESTER ST., OTTAWA.

**A. T. ANDERSON & CO.,**

CONTRACTORS FOR

**ELECTRICAL AND GENERAL MACHINERY.**

Complete installations of team and Hydraulic Power, Electric Light and Power Plants, Wiring and Construction for Arc and Incandescent Lighting. Agents for the celebrated "C. & C." Electric Motors.

75 Adelaide Street East,  
Toronto, Ont., Canada.

Estimates furnished and every information cheerfully given to intending purchasers. N. B.—Only first-class work on which a full guarantee will be given.

**The Casselman Lumber Co.**

CASSELMAN, ONT. Successors to FLATT & BRADLEY.

ESPECIAL GOOD FACILITIES FOR SHIPPING.  
HEMLOCK BILL STUFF OF EXCELLENT QUALITY.

ALSO MANUFACTURERS OF

**PINE, SPRUCE, ASH, MAPLE AND OTHER HARDWOODS.**

CORRESPONDENCE SOLICITED.

J. W. MAITLAND  
H. RIXON

J. G. AINSLIE  
W. STODART

**Maitland, Rixon & Co.,**  
Owen Sound, Ont.

**Saw Millers AND Lumber Dealers**

All kinds of Building Material kept in stock.

WE MAKE A SPECIALTY OF

**LONG BILL STUFF IN ROCK ELM, PINE, CEDAR AND HEMLOCK**  
QUOTATIONS FURNISHED ON APPLICATION

# THE CANADA LUMBERMAN.

VOLUME XII.  
NUMBER II.

TORONTO, ONT., NOVEMBER, 1891.

TERMS, \$1.00 PER ANNUM  
SINGLE COPIES, 10 CENTS

## RUSSIAN SAWMILLS.

DR. WALTER KEMPSTER writes from Wilna, Russia: "I visited a large saw mill, located upon the River Vilia, which flows through this place. The mill, a very substantial brick building, stands back from the river forty rods. The logs, some more than eight inches in diameter, and all twenty-one feet long, are drawn out of the water by horses, a heavy trace chain hitched to each end of the log and fastened to whiffletree serving as a means of hoisting them out. There is a horse at each end with a boy on the horse's back, and when the chains are made fast each boy cracks his horse and out the log comes. You understand it is not drawn out endwise but sidewise, the whole twenty-one feet scraping over the runways. In this manner the logs are drawn into the yard where they are piled up for winter's use. As the horses approach the pile the boys start them into a gallop and they skid them to the top of the pile on the gallop.

"In the mill there are two gang saws—the old, old fashioned kind 'up one day and down the next'—five saws in each gang. There are also some edging saws. The machinery is all in good order and everything about the place indicated prosperity.

"From the log yard the logs are hauled into the mill in the usual way and why they do not haul them from the water in the same manner is a mystery. All the boards are carried about the mill by men, not by carriers such as are used with us. It is laughable to watch operations in a Russian sawmill.

"The rafts are made up much as ours are, except that the logs are piled up three or four feet in each section, and the reason for this becomes apparent when I explain that for every section in a raft the owner pays the government a river tax of five roubles (about \$2.50). The logs come several hundred miles down the river, which is a fine stream even here. The raftsmen live on the rafts but have no shelter like the raftsmen on the Allegheny.

"The most pitiable thing about it all is the price paid to workmen. Sawyers receive five roubles (\$2.50) per week and board themselves. Laborers receive from thirty to fifty kopecs (fifteen to twenty-five cents per day and board themselves, working from 6 a.m. until 8 p.m. Many men and women too get only one rouble (or 50 cents) per week and board themselves. Fifty kopecs per day (25 cents) is the pay for a first-class laboring man, who is not a skilled mechanic, and no mechanic that I have found yet receives more than one rouble (fifty cents per day. I have visited mills of all kinds, carpenter shops, cabinet makers, machinists, wood carvers, brick layers and stone masons, and in short every trade, and seven roubles (about \$3.50) per week is the very highest price paid to the most skilled artisan."

## OIL IN BOILERS.

IT SEEMS to be proved beyond a doubt that kerosene oil has a beneficial action upon the interior of steam boilers in a section of country where lime water is used for feed. Some engineers open the boiler once a week and turn in from one to three quarts of either crude oil or kerosene. Other engineers follow the practice of injecting a pint or so of oil every day. Some men have rigged up special apparatus for injecting oil. This is hardly necessary, especially where a power feed pump is used. There is, or should be, a small pet cock tapped into the barrel of every power pump. If a bit of rubber hose is squeezed on over this pet cock, and the end of the hose dipped into the can containing the oil, it is quite easy to open this pet cock during the suction stroke of the pump and close it

during delivery. This action for a dozen strokes will suck up all the oil and send it en route to the boiler.

Where an injector is used a pet cock may be tapped into the water supply pipe just back of the injector. If the water supply flows through the instrument it may be necessary to throttle it slightly when oil is to be administered to the boiler. When this is done the rubber hose can be applied to the pet cock in a manner similar to that described for the power pump. When the injector is working well turn on the oil and it will be quickly soaked into the injector and discharged toward the boiler. Care must be taken not to open the pet cock to its full extent when passing oil through an injector, or the large body of oil acting differently from the water may cause the injector to "break." If this happens, the engineer may get a dose of oil and greasy water on his face and shirt front, but no more serious action will occur. The steam pump may be given oil in a similar manner, but it will not pay to harness up the air chamber pet cock for this purpose.

## OPPORTUNITY.

DO WE ever stop to think how much of human success depends upon opportunity? The world is full of square men who are industriously trying to fill round holes, and the men occupying the square holes are in like manner misfits. How many men waste the energies of an entire life in misdirected efforts simply because they have never found a fit opportunity for the development of such abilities as they possess. A man who possesses decided executive capacity, and is competent to handle great interests, or control an army of workers, perhaps plods away for years in some subordinate routine position, because the opportunity has never come for him to display his mental calibre. He has never struck the right line, is probably engaged in a business for which he is wholly unfitted and in which he will never be anything but a failure. Another, perhaps through a merely fortuitous circumstance, it may be an almost accidental connection with a man prominent in some special line, is placed in a position for which he happens to possess marked capabilities, although as yet undeveloped. He does not even know himself that he possesses any special fitness for the post. But with opportunity comes development. Manifesting continually increasing capacity for the business, he is pushed ahead, the scope of his authority broadened, and he becomes in time a type of the highly successful man.

Placed in a different position, one for which he had no aptitude, he might have run on in the same dull groove, gradually deteriorating into a mere machine, doing his work perfunctorily and without interest. But when he has found his special work he grows mentally with every day's experience, and finally rises to the extreme height of efficiency.

It is too often the case that the unsuccessful men, those who have made a failure of their life's work, have merely lacked the opportunity to develop what was in them, and in their failures are rather to be pitied than blamed. It is true that even persistent plodding will sometimes reach the goal of success, but the way is a long one, and the final rewards hardly commensurate with the toil involved.

That man is indeed fortunate to whom opportunity comes early in life, and who has the good judgment to grasp it while the way is clear. It is said of some men that they compel opportunity; but for one who succeeds in that effort there are many who fail. That occupation for which a man is adapted, by natural temperament, by physical and mental qualifications,

is the one to which he ought to devote his energies, for, although he may achieve a measure of success in other callings, it will never be so complete or so liberal in its material rewards as that for which he is naturally qualified. Let us have fewer square pegs in round holes.

## STAVELESS BARRELS.

THE *London (Eng.) Times*, tells of a remarkable invention of a German, that may do much to revolutionize barrel-making the world over. This is the account as given by the Thunderer:—

"It is doubtless a matter of general knowledge that the bodies of casks and barrels are composed of a number of tapered staves, which are assembled together, held in position and hooped up. By a novel and ingenious method of manufacture casks are now being manufactured from one piece of wood, and therefore without any staves, or, it may be said, with only one, the body constituting in itself a long, single stave. The method of preparing the body of the cask may be likened to the sharpening of a lead pencil by a pocket sharpener. The stem of the tree is first cut up into pieces or logs of a length according to that of the barrel required, and is then boiled for two or three hours in a closed vessel to soften the wood, a current of electricity being passed through the water the whole time. From the boiler the log of wood if taken to the machine, where it is held at each end horizontally between two points, much in the same way as a piece of wood is held in the lathe. Rotation is given to the piece of timber, which is advanced towards a broad blade fixed on a frame having a slot in it in line with the edge of the blade, just as in a plane, which the cutting part of the machine may be said to resemble. As the trunk of the tree is revolved against the blade a continuous sheet of wood is produced of any desired thickness. The wood is drawn out flat from the rear of the machine by hand onto a table. The sheet of wood thus obtained is cut transversely into pieces each of the required lengths for one barrel. The pieces are then passed through a grooving machine, which cuts the groove in which the head is eventually fitted. Another machine cuts V-shaped pieces at intervals out of the edges of the pieces of wood, which are then easily bent round into a cylinder and firmly hooped, the V-shaped slots enabling it to assume the necessary conical form at each end. There is thus only one joint in the body of the cask or barrel. The casks are afterwards dried in a special apparatus, after which they are ready for use. A factory is in operation in Germany manufacturing these casks, some of which we recently examined at the offices of the Oneken Patents Syndicate, 10 Old Jewry Chambers, London. We were also shown a model of the machine and some samples of wood of various thicknesses, including some exceedingly thin veneers.

## THE ELECTRICAL SAW.

IT HAS been noticed that platinum when placed in an electric current, is heated to a dull redness. This fact is the basis of the invention of an electrical saw, which will cut quickly and neatly the hardest wood. The device is made of steel wire, upon which is deposited metallic platinum. By connecting this modified wire with the terminals of four Bunsen batteries, the platinum is heated to a brightness, and the saw is ready for business.

## MYSTERIOUS MILLS IN THOSE DAYS.

M. R. MORRISON, an English traveller of the seventeenth century, while at Dantzic, Prussia, says that he saw mill "which without the help of human hands did saw boards, having an iron wheel which did not only drive the saw, but did also hook in and turn the logs onto the saw." Dr. John Dee must have seen a similar mill at Prague, of which he says: "I saw me a mill at Prague of which the devil himself was master."



### BAND SAW SPEED AND TEETH.

THIS is a question of much interest and hard to answer. There are so many conditions that affect a standard speed, that it is out of the question and would be absurd to recommend any certain speed. These conditions extend from the filing room to the foundation of the mill. If all mills were built on solid foundations, perfectly balanced, had good filing and care of saws, then a standard speed and space of teeth could be adopted.

My experience, and I have tested it from 6,000 to 10,000 feet per minute, is that it takes speed to cut lumber, that is, about 9,000 feet. If teeth are not of the right dimensions, they will not stand this speed in hardwood. Other surroundings being perfect, any saw cutting hardwood must have the right space teeth or a peculiar shape must follow. If the right space tooth is had for hard wood, it will cut soft wood, but requires to be longer to give dust clearance, which soft wood requires, provided the saw is put to its test. If too many teeth, they should be short with not so much hook and with a rounder gullet. This is necessary, that the dust may pack or maintain itself in the throat of the teeth.

Right here is where the whole trouble is with the band saw in hardwood. Each tooth *must* cut sufficient to form a chip, otherwise the kerf is scraped, forming a powdered dust which passes between saw and log, heating the saw. This is noticed by the dust being packed hard against the side of the log.

To get feed enough to take a chip does not require teeth closer than  $1\frac{3}{8}$  inches, and then 8,500 speed is best, with everything in the best of condition. My experience has been with oak, ash, cottonwood, pine (hard and soft) and cypress, and on saws from eight to twelve inches wide, 14 to 16 gauge.

As previously stated, I prefer  $1\frac{3}{8}$  inches from point to point on 14-gauge saws, speed 9,000; but on account of iron in every conceivable shape, from a nail to the blade of an axe, I have adopted  $1\frac{1}{2}$ . Teeth  $1\frac{3}{8}$  apart would not do as well on 8,000 as on 9,000; there is a liability to lose corners in knots, and it requires nice swaging to make them stand. Filers differ.

A saw that will run well in soft wood may not run at all in hard wood, but a saw that will run in hard wood, will certainly run in soft. The only difference in the teeth, is, being a little longer for the latter, as a certain kerf for soft wood will produce dust to consume more space than in hard wood. What is wanted is as few teeth as possible to do the work well, as the saw cuts lighter and will stand more feed.

As to the shape of the teeth, they must be shaped to have a straight back and as much hook as will make the tooth stiff enough to stand. The difference in 7,000 and 8,000 feet speed would require a stiffer tooth; that is, for a high speed it can be made a little slimmer, with a straight back. I don't think there can be too much hook. The practice of rounding backs on band saws will not work; my experience with the round saw is that very little rounding is needed, and that for light feeds.

A saw that is not well hammered will not stand 9,000 speed; it will assume a flapping or trembling motion, which deprives it of that steady, firm motion necessary for fast and good work. Defective brazes will soon play out on high speed. Anything that is not right about saw or mill will necessitate the reduction of the speed to 8,000, or less.

M.

### SAW MILL KINKS.

BY DIGS TOSMER.

IT is not an uncommon thing for circular saws to wobble a little; and when one is not skilled in the use of the hammer, very thin paper should be used to "pack" between the collar and saw on the touching side; the difficulty usually being to get paper thin enough. It is sometimes amusing to see how a beginner will be deceived in the amount a saw may seem to wobble. We have been often told, on sending out a new mill, that the saw was so crooked that it ran "out" over a quarter of an inch. To prove this, the owner should place a strip on the mill frame, the end touching the saw. Then, by slowly turning, the stick would be forced away by the

bulging side, and when the slack side came opposite the stick, a space would be seen that really appeared to be more than one-eighth of an inch wide, the bright surface of the saw making this distance very deceptive. By the means of a thinly whittled wedge, the actual width of this space was measured and found to be less than a sixteenth of an inch.

We were once greatly annoyed by a complaint similar to this; one which came near baffling all efforts to remedy it. Being so peculiar a case of "crookedness," we mention it. We finally discovered that the saw ran truly when the holding nut was screwed up with the hand; but when tightened with a wrench, the saw wobbled. This led to the discovery that in welding the saw-collar it was only stuck on one side, and yielded back on the other when forced by the wrench. We have wondered if anyone else ever met with a similar experience.

Before leaving this subject, we will mention another source of annoyance in saw-collars. This originates in the machine shop, and is caused by imperfectly turned collars. The lathe man cannot be too careful—First, to have the cutting tool sharp, the proper shape, and set to take a light chip, especially on the finishing cut. Secondly, to look closely for hard spots which may be found in the iron. These will cause a yielding of the tool which is almost imperceptible, and yet is sufficient to derange the running of the saw.

We have seen collars concaved gradually from the periphery to the mandrel. This is wrong, we think. The surface on which the saw is to bear should not exceed the distance from the pins on the outer edge of the collar. From the pins to the mandrel a slight recess should be made, which is a cross section of a collar, cut through the centre. The pins should be of the best cast steel and driven very tightly. Doing this will swell the iron around the hole, and the swell will extend to the surface where the saw is to rest. It is obvious, therefore, that after the pins are driven the bearing surface of the collar should be carefully turned, two or three cuts being sometimes necessary to secure perfect accuracy. A straight edge, when placed against the collar, should bear hardest at the outer edges. A thin coating of oil will serve best to show its bearing. Some allow a space between the straight edge and collar that will permit light to enter.

### A WORD ABOUT MILL FOREMEN.

A WELL proportioned and arranged mill allows the foreman to establish his reputation in many instances as an A No. 1. Such a mill, well-set, of course, will run for months without putting him to test. To his surprise a line shaft wrings in two. He flies around, finds a flaw in the shaft and a dozen things to clear his skirts. A line drawn through the boxes shows it to be a trifle out of line. This is sufficient to break any shaft, and only remains a question of time under heavy duty. Pretty soon one of the boilers needs patching. No cause under the sun for it, only that the boiler was defective, etc. The truth of the matter is, that he has allowed the engineer to blow out with fire in the furnace and refill with cold water. This remains only a question how long the rivets and sheet can stand this enormous contraction. It is not advisable to have such an engineer. But how long does it take a man to realize whether the foreman is up to his business or not? Not long. He nine times out of ten will hurry such jobs as cleaning boilers—in fact, slight what he can; the foreman can only lay it to the maker, etc. One Monday morning a battery of five boilers in a saw mill were found to be leaking. A new engineer had been lately put on. He had his way out of it, of course. He had found the engine to be one hundred and fifty horsepower, and in such "bad" condition that the excessive firing had burned or strained the boilers. The foreman coincided with him, and the mill owners had to stand a day's loss and pay a large boilermaker's bill. The competent engineer, who had been fired by the order of the new "cracked-up" foreman, was put on the black-list.

All mill owners cannot be practical mill men, but if they would only investigate the matter more closely they would save many hundreds of dollars annually by kicking out such men or making them bear the loss. Going through a mill just as the engine was starting up,

I heard a slight squeaking noise in the hub of a driving pulley. I remarked to the foreman that something was wrong there. He could not be told anything. Four hours later parts of that pulley were all over the mill, one part of the line shaft pulled down, the belt wound around the engine shaft. The foreman thought it amounted to nothing (the slight squeaking noise), and got out of it by scientifically arguing that the pulley burst from centrifugal force. The mill owner could only stand off and look. Had he examined the broken ends of the shaft and condition of the hub, he could have located an old break, and not have been completely deceived. A case of a seven-inch friction shaft, carrying a 24x24 friction pulley broke early one morning in a ten-inch cut. I discovered that this friction, which drove the main sixty-six inch saw, had been slipping a little. The engineer whose department it was in had tightened it all from one side. The other side of the friction was smeared with grease, by the new greaser pouring too much oil in the bearings which was very close to the edge of the pulley. The motion soon had it out to the edge and over the face. The engineer to keep me off the racket, tightened the other end of the shaft, which put the entire strain on the center of shaft, driving from about ten inches contact. This was another mysterious case. I at once saw the cause, by drawing a line and discovering the oiled surface of pulley. The engineer went. He should have charged the boy about those particular bearings, and should have wiped the grease from the pulleys and chalked them until no slipping was perceptible.

In my experience, I find that in most cases saw mill break-downs can be attributed to the neglect of the foreman. A competent foreman will at once call attention to parts that are too weak, and insist on duplicate parts. If such parts break he can not be blamed, unless in an extreme case of revenge, which no man of honor would do. A good foreman has sufficient mechanical judgment to pass readily upon a certain machine. He may not like the style and workmanship, but will make it go—will not kick it out because it's not what he is used to. A good gang edger was thrown out of a large mill for no other reason than that the saw collars had worn until the saws would not go straight. The incompetent foreman figured around the rollers to make straight lumber and could not; so cried out for a new \$600 edger. The mill owner bought it. While new it went well, of course. Other things turning up, and the mill owner making no money, realized his fate and let him go.

There are many good machines thrown out for the want of a few new parts. The competent foreman will keep a mill right up to its full capacity until worn out—that is, until the expense of keeping it up, which does not run in break-downs, but in replacing and keeping up parts, until the machine can no longer be kept to its capacity without more or less loss of time. Such mill men have a good bank account, have made money, and are ready to sell the old mill for what they can get and put in the latest. The mill men who are constantly changing do not make money in these competitive times. The old adage, "A poor workman grumbles at his tools," can be well applied to incompetent foremen.

### A STRANGER IN A STRANGE LAND.

SOME time ago a sea captain in the Pacific coast trade visited Australia, and there saw a large log which was being examined by the people of that country as a great curiosity. They were at a loss to know what the lettering on the log meant, and consulted the aforesaid sea captain in relation thereto. But he could not inform them, and having somewhat interested himself, made up his mind to learn from whence the log came, believing it to be from some point on this coast. Upon his return to this country he began making inquiries, and at last found a boom superintendent at Port Gamble who informed him of the meaning of the brand, B B, which showed the log to belong to Blackman Bros., of Snohomish. The testimony at hand would seem to warrant the assertion that one of Blackman Bros.' logs had found its way from the river into the Sound, thence into the sea and across the ocean for a distance of over 6,000 miles before being picked up on the coast of Australia.

**THE MAN WHO SAWS THE WOOD.**

You may talk of new inventions  
That attest the printer's power;  
Of the presses that can rattle off  
Ten thousand sheets an hour;  
Of the editors that want them  
For this glorious country's good;  
But the hand that rocks the hand-press  
Is the hand that—saws the wood!

**BRITISH OAK.**

THE oak is indigenous throughout Britain, and in former ages, before the clearing away of the forests had commenced, appears to have covered a very large portion of its surface, for even in districts where the natural or self-growing oak is now rarely seen, the remains of noble and gigantic trees are frequently met with, sometimes in alluvial deposits on the margins of our rivers, or in boggy places, covered with a layer of peat moss, which has been generated around them by the stagnation of water, caused by their fall. Several trees of large dimensions have been exhumed in tracts, where at the present day scarcely an oak of any great age, or that has attained one-fourth the size of those former denizens of the forest, are now to be met with. At Linden the trunk of a magnificent oak was extracted from a peat moss. This oak was covered by a layer of peat moss to a distance of about three feet, and was discovered by probing the moss. The trunk, with a small portion of one of the larger limbs, was with great labor and difficulty dragged from its miry bed.

The contents of the portion recovered contained 545 cubic feet., although the whole of the sap wood had perished. The timber was perfectly sound, and the tree, by whatever accident it had been overthrown, had fallen in the vigor of its growth. When sawn up the interior planks were found of a deep rich brown color, those nearer the interior darker, or approaching to black. A variety of elegant furniture had been made from the wood, but it has been found necessary, for fine cabinet work, to have it cut into veneers, as when worked in bulk it is apt to crack and become warped. The remains of other large oaks have also been met with upon the banks of the Tyne, the Alne, and other rivers, as well as the various bogs and morasses, and we mention these instances to show in a district, where at the present day nothing but recently-planted oak or dwarfish timber from stock shoots exist, that in former times the monarch of the forest grew luxuriantly and attained a splendid development; and also as an inducement to the planter not to neglect the liberal insertion of this national tree wherever soil and situation are found congenial to its growth. In other parts of England the oak still grows in all its magnificence of form and dimensions, and the remains of those ancient forests which are chronicled by our earliest writers, and which in the time of our Saxon ancestors spread over the greater portion of the country, are still to be traced in the venerable but living relics of enormous oaks, many of which are supposed to number more than a thousand years.

There may perhaps be some who suppose, from the slower growth of the oak and the height of time it requires to attain maturity, that they are likely to gain more and within a shorter period by plantations composed of other trees than oak. Such an opinion we conceive to be erroneous, at least with respect to all soils in which this tree will thrive, for we believe that greater advantages and equal profit may be obtained from mixed plantations in which the oak has been introduced in sufficient quantity to stand as an ultimate crop, for the number of plants required for this purpose and the room they occupy when quite young is not such to lessen materially the value of the necessary and periodical thinning of the other occupants which have been planted as secondaries. As compared with the larch, the Scotch fir and others of the pine tribe, or with the rapid growing poplars and willows, the growth of the oak during youth is undoubtedly much slower, being at only one-third the rate of that of the white poplar. The difference, however, in respect to the ash, the elm, the beech and some other forest trees is not nearly so great, as we find from Vancouver's observations that the relative increase in growth of various trees, taking them at ten years old, and fixing the oak as a standard, was as follows: Oak, ten; elm, sixteen; ash, eighteen; and beech, twenty.

**A GOOD FILER.**

BY J. H. MINER.

THIS is what over one-half of the mills to-day want and cannot get. There is no trade or occupation that pays the wages that a first-class filer obtains, and these wages are kept too much in view. There is no trade with apparent deception in it, and many men think the art a secret, and if they can catch on to a few points are out for big wages. If filers were not so conceited they would fare much better.

The capacity of the circular and band saw depends on the skill of the filer. Take the rotary saw of over half a century, and every day it is made to cut more lumber, and astonishing records are obtained. To a certain limit only the average filer attains. The close mechanical eye and judgment necessary are not found in one man out of fifty. Years of experience are not all that is necessary. It must be in the man. There are more men of long experience that cannot master the saw than in any other mechanical pursuit. The differences in capacity of mills should classify filers, but we find a man from a mill who is ready to talk of his own records and what he can do; in many cases only imitating some other man's chat.

If filers would not be contented, but try to improve they would succeed much better. In the art of hammering, many men claim to hammer when they do not know the principles of expansion. Their reputation is gotten up by taking a saw considerably run down, slack on the rim, which has not been treated to the following process, and the professional man hits the saw a series of blows usually in segment lines. Naturally anything from a center-punch to a sledge hammer would open up the body which would apparently help the saw. Delighted at the result he is soon out on the road or after another job. We often find such men carrying recommendations as hammerers.

The adjustment of any saw requires as close work as the finest chronograph watch; in swaging, filing and hammering, the utmost care must be exercised. A tooth not of the proportion set will lose its corners on heavy feed; the tooth may have the necessary body, but the steel may be deadened by the tooth being too dull, and the use of the upset. The pressure swage is best, but this, like all other machines, will do the work only as it is set. If the filer knows what he wants, he will get good work.

The automatic sharpener, in nine cases out of ten, is not properly used; that is an edge left on the tooth that will stay. The file is used to point up which throws the tooth out of square. There is not one filer in fifty who can file a square tooth. The hammering is the most essential thing. It requires a tension properly distributed.

There are many filers who can detect any irregularities in temper, and compensate for them in their work. The reason why many men do not succeed is that they do not know the force of expansion. The saw receives expanding blows where it does not need it.

There are two elements in hammering any saw, and they are keeping the plate true, and of proper opening to speed. It is not required of one man to know it all; but the filer who cannot show some mechanical skill outside of the file room is not much of a filer.

A man must be a natural mechanic, have good judgment, and the straightest eye of any man about the business. He will keep up with his work with all the mill sharp. The man who only files or gums a saw when necessity compels him, is not a good man. While it is not required of a filer to be a sawyer, he should know enough about the running of a saw to adjust it right. If the sawyer cannot make good lumber, it is his duty to see why; whether in the saw, lead of mandril, or anything else. A man well up in the business will fit up every saw precisely alike. Saw makers say this cannot be done, but it can, if saws are of the same gauge and teeth. The variation of temper the filer will compensate for, so that a sawyer practically has the same saw when running a half dozen or more.

**A WHOLE FOREST OF CHESTNUTS.**

"Don't you think the baritone's voice has unusually fine timbre?" "Yes, some chords of it."



Never lay tools or other things on belts that are standing still, for they may be forgotten and cause a break-down when the machinery is started.

If the strain on a pulley be so great that the screw already in place will not hold it, do not let them score in the shaft, but put in an extra screw or cut a key-way and put in a key.

To find the length of a belt when closely rolled: The sum of the diameter of the roll and the eye in inches, multiplied by the number of turns made by the belt, this product multiplied by the decimal .1309, equal the length of the belt in feet.

For users of steam power who are not skilled mechanics or not accustomed to run engines, a unique type of engine construction has recently come into vogue, consisting of a moving steam cylinder and moving valve and a stationary steam chest, thus dispensing with the various mechanical arrangements commonly employed, such as the eccentric valve rod, complicated connecting rods, slides, rockers, etc.

A French official industrial department issues the following recipe for preserving wrought iron chimneys and chimney flue from oxidation: Brush over the inside of the pipe with a mixture of coal tar and pine tar. Then fill it with wood shavings and chips and set fire to them. The tar is thereby calcined and adheres to the metal, and also covers its surface with carbon. A pipe so treated will last many years longer than one which is unprotected.

Where a person has frequently to put on pulleys on a line or counter shaft near the ceiling of a room, it is somewhat annoying and inconvenient: to use a ladder for such purpose, and a single little device which we have seen used in the shop, but it is not common by any means, consists of a pole of such size and length as is convenient for handling and will reach the top of the pulley. Two or three inches from the end of pole, a small iron rod four or five inches in length is attached so that it projects from the pole at right angles. When a belt is to be thrown on the pulley, the belt where it rests on the shaft is caught on the projecting iron and pushed back until the slack of the belt is carried beyond the pulley. The belt is then guided on to the surface of the pulley, where it catches, and being held by the stick is easily and quickly lifted on to the pulley, the stick and rod being carried out of the way by the motion of the belt. By use of this simple device a dozen belts may be thrown on in less time and with greater ease than a ladder could be brought and placed in position for putting on a single belt.

Apropos of boiler incrustation how singularly tenacious many engineers are of the idea that potatoes are about the best preventive of scale that there is. The reasoning runs thus: "Did you ever see the inside of a teakettle?" "Yes." "And did you ever notice how it was all furred up with scale?" "Yes." "Did you ever see a kettle used for boiling potatoes furred up like a teakettle?" "No." "Well, then, if you would use potatoes in your boiler you would not be bothered by scale." It never seems to occur to these geniuses that there may be another reason for the difference between the two vessels which will explain the different results. Thus, I presume no one ever saw the washboiler of a laundress scaled to any extent, and yet the boiler is not what she is apt to use in cooking her potatoes, but it is generally wiped out, and thus any sediment from the water is got rid of at once, while the teakettle is used for months at a stretch without being cleaned, and by that time it has acquired a coat of "enamel" which a cold chisel and hammer will scarcely budge.

There are three methods of producing forced draft, writes a correspondent of *The Tradesman*. One is a jet of steam admitted to the smoke stack near the base, through an annular pipe pierced with small holes. This system is not the most efficient and causes considerable loss of fuel as the steam that is used to create draft would do ten times as much work were it used in an engine instead of being used direct. The second method is that of forcing air into the ash pit of the furnace through pipes from a blower. This system is good especially if the air be first warmed by being forced through pipes in the smoke stack. The third method is in maintaining a "closed fire room," the stoke hole being made air tight, and blowers being used to force the air into the fire-room, from which it rushes into the ash pit and thence up through the grates. The principal defect of this system is that when the furnace doors are open the cold air will rush in, causing strains and perhaps cracks in the tube sheet and perhaps the tubes themselves.

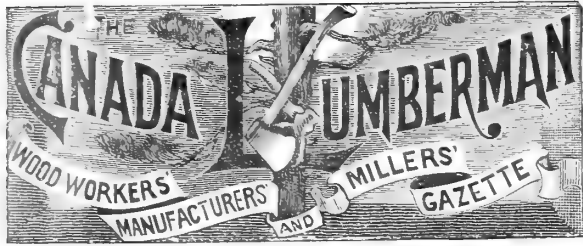

PUBLISHED ON THE FIRST EACH MONTH BY  
ARTHUR G. MORTIMER.

OFFICE:

75 CANADA LIFE ASSURANCE BUILDING,  
TORONTO, ONTARIO.

TERMS OF SUBSCRIPTION:

One Copy one Year, in Advance, - - - - \$1.00  
One Copy six months, in Advance, - - - - 50  
Foreign Subscriptions \$1.25 a Year.

Advertising Rates Furnished on Application.

OPINIONS ON THE LOG DUTY.

THE reciprocity negotiations between the United States and Canada that were on the carpet for October have been declared off in the meantime. President Harrison's alleged reason for the postponement is the precarious condition of Secretary Blaine's health. The postponement of negotiations some months ago, when the Canadian representatives had by appointment actually reached Ottawa, was due to the inability of the President to give the needed time to the conference, having on hand a political tour through certain of the States. This time it is Mr. Blaine's turn to play bluff, for a dispatch of 25th ult says that the Secretary has reached the capital, and appears in splendid health. THE LUMBERMAN has no interest in this little by-play at political battleground and shuttlecock. Its direct interest is in the anticipated relation of reciprocity to the lumber industries of the country. Our own government did not move in the matter during the meeting of Parliament, waiting the result of the expected conference; and with the meeting still hanging in the balance, nothing better than speculation as to results is likely to be realized just now. Anything of value that will shed new light on the question, or make more clear the ground already covered, we shall in the interim be pleased to lay before our readers. We observe that Mr. Loveland, the active head of the Saginaw Salt & Lumber Co., a firm largely interested in Ontario lumber, and of whose lumber operations a sketch is given in our Michigan letter, has been expressing himself to an interviewer on the question. He states that his advices from prominent lumbermen in Canada, leaves very little reason to suppose that our government will reimpose the log export duty. "A reimposition of the duty," he says, "would at once increase the duty on the 600,000,000 feet or more of manufactured lumber which Canada annually markets in the States, \$1 a thousand." In his opinion if the duty were re-imposed there would not be one-half the quantity of Canadian logs cut by Michigan owners as at present. "Not only this," adds Mr. Loveland, "but all the supplies for the operations in Canada are purchased there, all the horses are bought on that side; I purchased 40 only a few days ago for our company's camps there, and all of the men for the camps are hired there, all of which benefits the Canadian people. If the log export duty should be reimposed the result would be that the buying of Canadian timber by Michigan lumbermen would be largely curtailed."

The *Mail*, discussing the subject at some length in a recent editorial, apprehends unpleasant consequences should the Dominion government reimpose the log duty. Irritation would follow reimposition. The *Mail* says:—

The Americans are now aware that Canada has for many years been a large importer of American logs down the St. John and elsewhere—a trade which they cannot check by an export duty, as their constitution prohibits such an impost. The export duty having been removed, its reimposition would attract a degree of attention that was never given to the subject before the repeal of the duty, and no doubt the result would be that, as retaliation in kind could not be resorted to in consequence of the constitutional prohibition of any export duty, the case would be promptly met upon the

assembling of Congress by a joint resolution adding the export duty on logs to the import duty on lumber imported from countries imposing an export duty. Under this arrangement, if the export duty was the same as when repealed, the duty on pine would be \$4 and upon spruce lumber \$3 per thousand. This course would force an ignominious backdown upon our government, and the export duty would again be removed under circumstances less pleasant than in October 1880."

It is not to be forgotten that there is no love lost between the *Mail* and the Abbott administration, and besides the *Mail* is the Canadian champion of reciprocity between the two countries, and to the extent that its convictions are undoubtedly strong on this question, in that measure it may write with a bias in the one direction.

The *Canadian Manufacturer* the straight-out apostle of protection to every form of Canadian industry, devotes several columns of its latest issue to a discussion of the lumber and timber trades in Canada. It quotes at some length from the speech of Dr. Spohn, MP. for East Simcoe, excerpts from which we publish in another column. Our contemporary contends that the Canadian government made a fearful and foolish mistake in allowing themselves to be 'brown beaten and intimidated' by the United States government, and in the face of this threat to have removed the log duty.

The *Manufacturer* goes on at some length to say:—

"Before the imposition of that duty it was found that Canadian forests were being depleted to supply American sawmills, and it was hoped that the export duty would encourage the manufacture of the logs into lumber in Canadian mills; and it had this effect. The American government felt keenly the loss caused by this transfer of business from their country to Canada; and the plan to recover it was by raising their duty upon lumber. The answer of the Canadian government to this menace should have been not a back down by the removal of the export duty on logs, but an increase of the export duty to \$3, the old duty of \$1 only to be enforced whenever the United States government might see proper to reduce the import duty to that amount."

This is undoubtedly strong ground to take, but in the opinion of our contemporary it is the only right position for Canada, and the immutable law of supply and demand would operate here the same as it does in everything else. "We know that the American market stands in imperative need of Canadian lumber."

The Sault Ste. Marie *Pioneer* published in the centre of an important lumber section sees only disaster ahead. It says:—

"In a few years at longest—unless sooner restrained—these grand pineries will have been stripped of their timber by the United States mill men, and Canada will be left with a thousand miles of pine stumps to remind her of the prodigal waste of one of the richest territories in the world. Two hundred years of careful industry cannot replace the timber which has already been taken from thousands of acres. How long will it be before such wilful waste is overtaken by woeful want? Are all the men who are elected to Parliament lumberers or their agents, that not one word of protest is to be heard in local or federal legislatures against the almost ceaseless destruction of one of the greatest sources of Canadian wealth. Verily our land is being laid waste by strangers, and the source of Canadian wealth is rapidly disappearing without adding to the manufacturing interests, industry, or revenue of the Dominion."

WOOD FOR STREET PAVEMENTS.

JUST at a time when the movement in Toronto and many of the larger cities of the States is to abandon the wooden pavement for asphalt and kindred compositions, word comes to us through European travellers that the wooden pavement is coming into increased favor abroad. We are discarding it in this country for the reason that it seems to be no more than put down before repairs commence; and on many of the streets of this city, where the charge can neither be laid to the door of old age, nor heavy teaming, the wooden pavements are in a more unpassable condition for driving than the most primitive country road. Nor is the record from a sanitary view encouraging to this form of roadway; at least popular opinion attributes to the block pavement its full share of evil for the several epidemics of greater or less virulence that from time to time show themselves in our cities.

This is an indictment that does not place wood on top for the important purposes of road-building. At

least the evidence quoted; and we do not pretend to gain say it, does not place it in a favorable light for these uses. At the same time, however, that it is receiving its condemnation here and elsewhere, we find not only Europeans looking with favor on wooden pavements, but cities on this side of the water, despite the damaging testimony against the cedar blocks, are making large plans for the use of this particular pavement. The city of Rockford, Ill., is a case now before us. The authorities there are laying cedar block pavements, but they do not lay them in the usual way. Instead of placing them on hemlock blocks, they will be placed on a base of six inches of rubble, heavily rolled, and two inches of sand. This method is not without good authority to support it, those who should know contending that by pursuing this course the pavement will wear much longer and make a better pavement by being upon a firm body. On general principles wood should make a satisfactory and durable pavement. But if the plan of using the wood in the construction of the pavements is faulty an unfair sentence is passed upon wood. It is known that in this country timbers and in not a few cases shingles are found that have withstood the blasts of our severe winters for one hundred and even one hundred and fifty winters. While in Norway wooden churches are standing, with timbers of nothing harder than Norway pine, that have braved the fell frosts of these arctic winters for seven hundred years. The preservation in this latter case is attributed largely to the fact that they have been coated over and over again with tar. The standing timbers of a country church and the cedar blocks of a city roadway, which have peculiar hardships to endure, are not parallel cases; but the inference is clear, that proper preservative measures must be employed to give enduring qualities to wood under whatever conditions, favorable or otherwise, it may be used. Let us give the products of our forest a fair show for wooden pavements, as we would for any other purposes, before we pronounce too vigorously against them.

LUMBERMEN BOYCOTTING LUMBERMEN.

THE methods of the boycott are not to be restricted to workingmen's grievances only. The contagion has caught the Pine Lumbermen's Association of Winnipeg, Man. The members of this association have taken the position that they will not sell pine lumber to dealers who handle spruce lumber. The question was brought before the Winnipeg board of trade a week ago, and after considerable discussion, the following resolution was passed:—

*Resolved*, That this board views with strong disapprobation the decision of certain pine lumber manufacturers of the northwest to refuse to supply lumber to dealers who handle and sell spruce lumber, believing such decision to be direct interference with the legitimate flow of trade and a tyrannical attempt to hamper and coerce trade to the benefit of the few and against the interests of the many.

The resolution, on instructions of the Board, will be forwarded to the lumbermen's Association and also to the several boards of trade in the province.

However desirous it may seem under certain circumstances to give a special push to one particular line of merchandise, at the expense of another line of the same class, uncertain ground is taken, when the methods employed to accomplish this end are in contravention to the true principles of trade and commerce. And of all the means that can be used to accomplish a business end none are more absolutely objectionable than the boycott. There is an ugly spirit of arbitrariness about it to which no man will submit except under power of a force that cannot be conquered; and no business man should ask another to be placed under its domination.

We would want the pine lumberman of the Northwest provinces to secure as large and profitable market for their pine as the opportunities and extent of the market will permit; but let them be assured that this cannot be accomplished by any methods as restricted and imperious as the boycott.

R. J. S. DRINKWATER, ORILLIA, ONT.: "You must allow me to compliment you on the perfection that your paper is coming to or rather has come to."

WM. LEES, FALLBROOK, ONT.: "I think THE LUMBERMAN, a most excellent paper."



## EDITORIAL NOTES

WOOD is to be at a discount in future in C. P. R. trestle work. As a result of the recent tour of inspection made by the chief officers of this company, it has been decided to replace all the wooden trestles with steel structures. The cost is estimated at something over two million dollars, but the directors believe the consequent lessening of the schedule time between Vancouver and Montreal will repay this immense outlay, since trains will be able to run at considerable higher speed over steel bridges than over the best class of wooden trestle work.

THE favorite wood for paving purposes in London is the jarrah wood, imported from Australia. An inquiry has been recently set on foot to determine whether some other of the Australian woods notably red gum would serve as well as jarrah wood, but the testimony goes to show that while substitutes are used in some of the Australian cities for jarrah nothing that is offered is quite as satisfactory. They all lack the lasting qualities of jarrah. The inquiries further show that the supply of jarrah is abundant and that there need be no apprehension of the supply running short for many years to come. Wood paving grows more and more in favor in the European cities.

THE durability of timber under certain conditions is illustrated in a foundation of red pine planks, taken from a sewer in Sparks street, Ottawa. The sewer was constructed from 32 to 38 years ago. It consists of a foundation of red pine planks laid transversely, on which two side walls of stone are erected, which are covered over at the top with heavy round cedars. The cedars at the top are all, though still apparently quite serviceable, in a more or less advanced state of decomposition. The planks, however, are to all appearance as sound and hard as on the day they were put down. It is another proof that timber kept constantly submerged in water keeps in good condition—unless sewage has a special virtue as a timber preservative.

THE *Southern Lumberman* celebrates its tenth birthday by the issue of a special number descriptive and illustrative of the progress of the lumber and timber industries of the Southern States. Our contemporary is to be congratulated on the general "make-up" of its anniversary issue and on the gratifying progress that it has made during the first decade of its existence. The opening up of the lumber industry of these states is of comparatively recent date. It was not till 1875 that any vigorous effort was made to realize the rich stores that time has since shown exists in these southern forests. The walnut and cherry timber of Indiana began to fail, and buyers, seeking for other pastures green, began to flock into the hardwood forests of Tennessee. The early bird, in this case, reaped the reward. The value of this hitherto unrecognized source of wealth was not realized by the people, and before its riches had dawned upon them, millions of feet, including the bulk of walnut and cherry, were bought at about one-tenth its value. This was true also of ash, and to some extent, of poplar and oak. History repeats itself in the case of all our natural products. The adventurous prospector, who has often to brave the ridicule and prejudice of friends, gets in on the ground floor and makes his pile. We see no reason why he should not. It requires courage and foresight to be among the pioneers in any cause; success does not always crown the work of the pioneer; when it does, he has generally well earned it. The primitive methods of manufacturing and marketing, that have been common to all lumbering sections in their early history, were with the South in the days of the seventies. To-day they are as well up to the times as most of the older territories. Interest just now in these states gathers around yellow

pine. There people are very sanguine of the uses and value of this wood, and whilst some discount must be made for native enthusiasm, indications tell of good value having its existence in this particular timber. Tennessee is the chief lumbering state of the south, where there are now 436 saw mills, 142 planing mills and 20 shingle mills. Of these 41 (including twelve saw mills and ten planing mills) prosecute their successful industries in the city of Nashville. They have a daily saw mill capacity of 456,000 feet. The lumber handled or consumed by them yearly is 229,350,000 feet. We are not so far north in Canada that we do not find an appreciative interest in the welfare of those engaged in the timber interests of the Sunny South.

NEW YORK is again threatened with a lumber "tie-up." The trouble is a continuation of the labor difficulties of the early summer. At that time, as a result of united action by the members of the Lumber Dealers Association the men were badly beaten. It was an ugly licking for the walking delegate, and he continues to smart under it. He would again stir up the men and practice his old tricks, and it is an effort in this direction that has given rise to present rumblings of a fresh fight. *The Lumber Trade Journal* of New York, which carried through the former contest with marked ability and success, very plainly warns the men that if they allow themselves to be influenced by these agitators, and a single dealer in the Lumber Association is boycotted that every yard in the district will shut down and the men will have to meet their fate with a cold winter before them. It is to be hoped that for the sake of the families of the men, if for no other reason, that wise counsels will be allowed to prevail.

RECENT government returns furnish some important particulars of the volume and character of lumbering operations in Manitoba and the Northwest Territories. We are told that there are 19 mills in operation within the Winnipeg agency cutting under government license. The total amount of dues collected for timber within the Calgary agency during the year amounted to \$8,232.88, being a decrease of \$8,578.24. The price of lumber at Calgary was from \$12 to \$18; at Cochrane, \$12 to \$16; at Fort McLeod, \$15 to \$43; at Lethbridge, \$30, and at Cypress Hills, \$13. Two saw mills were cutting lumber within this agency last year under government license, and several portable mills under permit. The total amount of dues collected within the Edmonton agency was \$4,910.59, being an increase of \$868.86, as compared to the previous years. The price of lumber at Edmonton during the year was \$20 to \$23, and at St. Albert \$23 to \$25. The agent reports three saw mills in operation within his agency. The total amount of dues collected in the Prince Albert agency was \$7,689.91, being an increase of \$3,596.32 over the previous year. Lumber sold at Prince Albert from \$20 to \$42, and at Battleford from \$30 to \$35. There is only one saw mill in this agency cutting timber under license, namely, the one at Prince Albert, erected by Moore & McDowell in 1876. There are, however, several mills at Prince Albert and Battleford cutting under permit. Saw mill returns received at the head office give the following quantities of building material as having been manufactured and sold during the year within the five agencies: Lumber, 30,605,906 feet; sold 27,097,480. Shingles, 1,449,916; sold, 1,610,247. Lath, 156,402; sold, 142,146. Sixty-four licenses to cut timber over a total area of 2,312.88 square miles were issued during the year. The number of applications during the year to cut timber was 88, of which 48 were for licenses to cut lumber in Manitoba and the Northwest Territories, and the remainder to cut timber on Dominion lands in British Columbia. The number of applicants during the previous year was 81.

A RETURN brought down at Ottawa towards the close of the session showing that 42,000,000 acres of land in Manitoba and the Northwest Territories had been granted to railways, and the same policy being continued has brought from the *Winnipeg Commercial* a vigorous and outspoken protest. This journal, in order to make clear to its readers what this "dissipation

of the public domain" means, points out that the entire superficial land area of the province of Manitoba, including swamps and all unutilized land, is 41,002,240 acres, so that the gift to railways exceeds by a million acres the whole area of this province. We need to have a question of this character placed sometimes in this bold shape to realize fully its import. Our contemporary follows up its protest by showing that as yet the railways that have been built, influenced by this prodigal gift, cover only a small portion of the country, and "if land grants are to continue until all parts of the country are opened by railways, there will not be land enough in the entire country to satisfy the railways. The railways will own all the land, and still be unsatisfied." Railways have the power, apparently, to hoodwink governments and corporations with a child's innocence that is foreign to anyone else, but that is perfectly indigenous to them. No one is so unfair as not to concede to the railways of the country well-deserved merit for the important part they have occupied in the development of the country. But there is a wide gulf between credit-earned commendation, and an insatiable hoggishness that breeds with too many railway corporations. The people have rights, the country has rights, that must be made a consideration with governments, just as much, as the alleged rights of railway companies. If a protest to avail anything is to be entered it cannot be done too soon. We may make up our minds that whatever the railway companies secure they will hold; there will be no giving back anything. A little regiment of municipalities in this province have had some experience, if not in land giving, yet in bonus granting to railway companies, and in the interim of careful second thought, they know to-day, just how much their generosity has cost them, and how little, in too many cases, they have for their liberality. The objection to this principle of bonusing comes with enlarged strength when it applies to public land. *The Commercial* states a true principle when it contends that the public lands belong to and "should be held by people." We agree with our contemporary that the time has come to cry a halt to this policy, which if not seriously felt now, will certainly "in the future prove disastrous to the country."

TORONTO has had an avalanche of failures in building and lumber circles during the past month. Among the smaller concerns that have gone under may be mentioned Hammon & Williams, builders, of North Toronto, who assigned to Campbell & May with liabilities of \$3,000, and assets nominally the same. H. Lambert, another builder in a small way, is seeking a composition with his creditors. Herbert A. Matthews, proprietor of the Toronto Hardwood Company, has assigned to H. J. Watson. The Bloor Street Lumber Company is liquidating. The company consists of Stephen Wilcox, H. H. Mullin, of this city, and T. J. Hammil, Barrie. Direct liabilities are placed at \$9,800, and indirect \$9,000. The assets are about \$9,000—largely book debts. The surprise of the trade has been the financial embarrassment of William McBean, the extensive builder of what is familiarly known as speculative properties. His affairs have been placed in the hands of A. E. Osler. Mr. McBean's trouble is in being "land-tied," and unable to sell owing to the depressed condition of the real estate market. The amount involved in the failure is from \$250,000 to \$300,000, while it is claimed there is a surplus of \$90,000, but this is conditional on the assets realizing what is deemed their proper value. What the outcome will be it is just now difficult to state. These several difficulties will have no serious effect on the lumber trade outside of the firms, that may be interested as creditors, and we do not know that any of them will be hit to hurt very badly. The builders who have gone under are sufferers from the depression in building operations in the city. As we have pointed out before in these columns, speculative building in the city has for some years been carried on in a measure altogether in excess of the actual requirements of our population. The reaction that has set in is perfectly healthy, and whilst it will pinch some, and others it will squeeze pretty hard, the outcome will be for the general good, and will not be without a salutary effect upon some enthusiastic spirits who are more noted for their ability as boomer than level headed business men.



**HUGO B. RATHBUN**, founder of the Rathbun Co., Deseronto, Ont., is an American having been born near Aurora, N.Y., in 1812. He established himself in business at Deseronto, then known as Mill Point in 1848. He died in 1886, and the extensive business is to-day managed by his eldest son, Edward W. Rathbun. The company owns and operates 350,000 acres of timber land under government license, 57,000 acres of deeded timber lands, 7,750 acres of timber rights only.

P. D. Gordon, of Pembroke, Ont., in company, with W. R. Thistle, of the extensive lumber firm of Thistle, Carswell & McKay, of Calabogie, Ont., have been enjoying a business and pleasure trip on the Pacific coast. Mr. Gordon says that he has been especially interested in the sawmill part of their observations. He states that it is a treat to watch the cutting of the large timber. He saw a big log cut which was 52 feet long by 41 inches at the top end, without a knot in it.

Miss Jessie Alexander, Canada's popular and talented elocutionist, recently returned from a trip through the Northwest and British Columbia. It is needless to say that she was delighted with the country and believes that the one who is yet to write Canada's poem must pay a visit to the Pacific coast and drink in the wonderful inspiration that comes from the scenery of British Columbia. She tells how, "We drove out one day to see the famous big trees in Vancouver park, and we found a party of six gentlemen just grouping inside one to be photographed. Four were mounted and the others were in a carriage. The huge tree held both horses, vehicle and men, then there was room for us to join the party."

The large blocks of burnt timber limits in the Sudbury section, burnt over during the past summer and placed on the market by the Ontario government, were sold by tender during the month. The occasion of opening the tenders brought to the city a number of prominent lumbermen, among whom were W. R. Thistle, Ottawa; R. A. Klock, Klock's Mills; T. B. Chapin, Saginaw; S. B. Hill, Saginaw and Joseph Williams, Goderich. The quantity of lumber was estimated at over 50,000,000 feet, and the whole was secured by four well known firms, realizing \$122,000, exclusive of the regular timber dues, which will have to be paid as well. The purchasers were: Hill & Booth, Pembroke, 30,000,000; R. Booth, Ottawa, 5,000,000; Moran & Co., Pembroke, 5,000,000, and Walters & Co.; Lindsay, 13,000,000. Hon. Mr. Hardy, Commissioner of Crown Lands, on being interviewed on the sale, expressed himself as well satisfied with the prices obtained.

I continue to meet with various curious "finds" of interest to the lumber trade. Here is a budget of them this month. In the September LUMBERMAN readers will remember the "find" of a walking cane embedded in a large silver maple that had been cut on one of the streets of Galt, Ont. This town is ambitious to celebrate itself in this line. The other day while some Galt boys in Ward 1 were cutting up a portion of a pine stump the axe struck something hard, and an examination showed it to be a flint arrow-head, which in the days of long ago had been driven into the tree, doubtless by some Indian when testing his bow or shooting at a mark. It was buried in the wood between six and seven inches. In a sawmill in Spottsylvania county, Va., in sawing a pine log two feet in circumference, the saw went through the butt end of a twelve-pound shell which was embedded in the log out of sight. It is supposed that the tree was about nineteen inches in diameter at the time the shell was fired in 1863, as these trees grow about a quarter of an inch a year. A curi-

osity has been found in Washington. It consists of a very large moose horn grafted in the base of a tree. It has been in that position for years, as the tree has grown around it so as to get such a grip on it that cutting the wood away is the only way of separating the two. It was found near the Betty O'Brien mine on the highlands south of the town. It is evident that at some remote period a huntsman was chasing the monarch of the woods, who, in running away, was caught in a tree, and in trying to extricate himself the horn was broken off.

Isaac Cockburn, of Gravenhurst, Ont., one of the best known of the lumbermen operating largely in the northern section of the province, returned recently from an extended trip in British Columbia, Washington, Idaho, Montana, Dakota, Minnesota, Manitoba, and the Canadian North-West Territories. He went in the spring by way of the Northern Pacific to Spokane Falls and struck north for the lumbering districts, visiting Tacoma, Seattle, Victoria, New Westminster, Vancouver and other points. He was of course interested in the methods of lumbering on the Pacific coast. These operations are on an extensive scale, but in Mr. Cockburn's opinion the system of taking out lumber is open to much improvement. The methods of fishing in the rivers in the west are unique. A large revolving wheel is used which throws the fish into traps, and the barrels filled with fish are sent floating down the river like sawlogs to the various canneries. Minneapolis impressed him with its fine buildings and the extent of its lumbering business. But no point was, in his judgment, open to more favorable commendation than the Province of Manitoba. He considers it far superior to Dakota and Montana the other side of the boundary. He visited every part of Manitoba where there was railway connections and part of the territories. There is no country like it for the poor man; no where can he get a like start in life with the same certain prospects of success. He met with a man who four years ago was working at \$28 a month, and this season had thirteen binders at work in his field and would be likely to sell \$16,000 worth of wheat.

J. H. Gilbert, of the Hollister Bros. Lumber Company, of Saginaw, Mich., has expressed himself thus in regard to Canadian lumber matters: "I have been looking over lumbering operations in the Georgian Bay region. Eighty million feet of logs have been sent across from that section to Michigan this season, and next season the quantity will be pretty nearly doubled. Howry & Sons sent over 28,000,000 feet, and have camps at work cutting actively. Thomas Pickard, a jobber for the Emery Lumber Company, who has contracted to put in 200,000,000 feet of logs with about five years to do it in, says he will bank 40,000,000 feet this fall and the coming winter. He is operating a logging railroad 12 miles long, and is hauling 100,000 feet of logs daily. Sibley & Bearer had 11,000,000 feet of logs hung up, which were sold last spring but did not come out. Bearer was over there last week looking at a tract of pine, with the view of further investment. The woods in all regions are full of land lookers, the removal of the export duty on logs having stimulated Michigan men to invest in Canada pine. While the quantity of timber is inferior to that in Michigan, the condition of lumbering, the climate, proximity to market, etc., are so nearly like those in the peninsular State, that it is a question if Canada does not offer a better field for operations than any other locality further west or in the south. The market on the east side of Lake Huron is not as good as on the other shore, and for this reason the Folsom & Arnold mill and the Emery mill have been idle this season, the owners preferring to raft the logs across the lake."

The recent sale of burnt timber by the Crown Lands Department of the province, particulars of which I have given elsewhere, brings to the front the question, how best to preserve timber damaged by fire. Worms if allowed to have their own way will lose no time in getting at the damaged timber. They immediately commence boring and the damage done is irretrievable. I have before me at this writing, a letter from a lumberman asking what can be done to

stay the ravages of the worm. The question is difficult to answer. One thing is sure no time should be lost in cutting the pine, peeling the bark, and getting the logs into the water. One lumberman has stated as a result of personal observation, that in upper Michigan, where forest fires had prevailed, the bark on pine logs was being opened and salt inserted as a preventative of destruction by worms. This would be an expensive method to apply to a large tract of timber. An American operator, who has become disgusted at efforts to save burnt timber, is reported to have said that "the best way to treat burned pine was to punch up and continue the fire until the timber is reduced to ashes." This man of course was a little mad, but it shows the difficulties that beset the matter. It is a pity that we cannot apply to our burnt timber in this country the charm which is said to surround a sacred log of yellowish colored wood standing just outside of Ch'li Hua gate, Pekin. The log has remained in its present position since the fall of the old Ying dynasty. It is in good preservation and has commanded the respect of all classes and conditions of people. Insects in China usually make inroads in timber in a very short while, but they are said never to alight upon this sacred tree trunk, and it is true that they have not left a single trace of their work upon it, while the timbers in every direction are a perfect honeycomb of insect work. The Chinese people believe that the log is the habitation of some god, and on that account gather and worship at its base at least once a year.

"Perhaps some one else can tell why," remarked Mr. Meaney, manager for Robert Thompson & Co., wholesale lumber merchants, "but it does look as if the United States government were not anxious to talk reciprocity to the present Canadian government. President Harrison and Secretary Blaine between them manage to have a neat little excuse ready whenever the time comes for the commissioners of the two countries to get together. Some day may be something will transpire when these two peoples will actually get down to business and then we will know where lumber stands in the deal." Our conversation was interrupted here by a telephone summons to Mr. Meaney to attend a meeting of creditors. Interesting business, I remarked. "Yes," said the genial lumberman. Been a good many local failures during the month? "And there will be more of them before the snow falls," he added. "General lumber trade is, taking it altogether, in a fairly satisfactory condition, but local trade is far from healthy. We are tired of carrying many of these men and have drawn the lines of credit very close in the case of the average city builder. One does not know what day any one of them will drop. It is the old story of being brought into existence and carried on the real estate inflation of a year ago. Now the bottom has fallen out of speculative building and there is nothing for many but to go under." Would not a reduction of the time on which lumber is sold save the jobber from at least part of the loss made by these constant failures? "Certainly replied Mr. Meaney. Three months' credit on lumber, which is now the rule of the trade, is absurd. Lumber should be cash, or at the most thirty days; were this so we would be able to keep down many an account that on a three months' basis soon grows to large proportions. You smile and ask, why don't we do it? Without any exception the wholesalers agree that a change should be made, but we go no farther. We never get any nearer together than to say it should be done. In Hamilton, where our firm has a branch, it is done and works to the gain of every dealer." It appears to me, I remarked, that the dealers here are much in the same box as the Chicago wholesalers at the present time. They are selling lumber at prices that represent no profit. Every one of them does it. All agree that prices should be raised, but there is not among them one who will take the initiative. You need, as they need, some one like Joan of Arc, to rise up from the ranks, and give the order to advance. No one will take the step of his own account for he is afraid he will be alone. "That is so," said Mr. Meaney as he left to see what show there was for a dividend in the meeting calling him off. "I wish THE LUMBERMAN would prove the Joan of Arc."

### A PLEA FOR RECIPROCITY.

Bearings on the Lumber Interest—Effects on Manufacturing—A Budget of Facts and Figures—  
Speech by Dr. Spohn, M. P.

**F**OLLOWING are extracts from a speech delivered by Dr. Spohn, M. P. for East Simcoe, during the recent session of the House of Commons. Dr. Spohn represents a constituency largely interested in lumber and his speech was confined chiefly to the one subject. Whether or not one agrees with the conclusions reached, the speech deserves a careful reading for the information and many important facts that it contains. Dr. Spohn said:—

"Of course the lumber interest has, in the course of the last ten years, greatly increased; as the lumbermen employ better machinery they can consequently turn out more lumber. However, in 1880, according to the trade and navigation returns, the export amounted to \$16,530,000, and in 1890 it amounted to \$26,071,000. Taking that same ratio, we find that the lumber trade in 1891 will put out something like \$50,000,000 worth of lumber, and be worth over \$600,000,000. In 1881 the mills used up, according to the census returns, in raw material, \$21,134,000 worth, and the output was \$39,326,000 worth, and

#### THEY PAID IN YEARLY WAGES

\$8,347,000, and the total value of the lumber trade was in 1881, \$471,912,000. The lumber interest employs 61 times as many hands as all the sugar refineries, 156 times as many as all the distilleries, 234 times as many as the oil refineries, and the binder twine combine is simply nowhere. There are 150 saw mills in the three ridings of Simcoe. One firm cuts 75,000,000 feet a year, another 18,000,000 feet per year and another 17,000,000 feet per year, and so on. In the town of Midland there is but one saw mill running to-day. All the others are closed. One of these mills which is closed cut last year nearly 18,000,000 feet of lumber and employed, in its different departments, 380 hands. That mill has been shut down, and the logs, which would otherwise have been cut in Midland, are

#### NOW CUT IN MICHIGAN,

and these 380 hands and their families have been compelled to follow the logs, thus depriving Canada of many good citizens, and the town of Midland is thus becoming depopulated and is losing the advantage it would gain by the expenditure of this large sum of money, were the logs cut there as they should be. But this is not an isolated case. What affects Midland affects all the lumbering towns and cities in Ontario. For instance, the town of Gravenhurst should be the manufacturing centre for the Muskoka Lakes, but this affects that town as it does every other town and city in Canada. I have been speaking of the effect of the McKinley Bill on the lumber trade as it affects us on the Georgian Bay, but now I propose to come nearer home to some of you. Some people think that because the logs cannot be towed from the Ottawa Valley this does not affect the Ottawa Valley, but I will show you that it does affect the lumber trade of the Ottawa Valley as it affects the trade of the Georgian Bay. I am informed that you had a box factory in Ottawa which was run by E. H. Barnes & Co. and employed 150 hands, but, when the United States put a 35 per cent. duty on boxes, that box factory shut down; but that is not the whole history of your box factory, E. H. Barnes & Co. took the machinery out of the Ottawa box factory and carried it to Rouse's Point, on the other side of the line, and they are there now manufacturing boxes for the American market, and the people of Ottawa lost the factory and the 150 hands and their families, and the United States gained. Further, E. B. Eddy had a box factory, but, like E. H. Barnes & Co., it was compelled to shut down. Having given these examples to show the state of things in the east and in the west of the Province, I have no doubt that the same state of things exists more or less over the whole country. Still further, the effects of reciprocity would be more beneficial to the country, because there would be a great variety of wood manufactures started at once. In the west, a planing mill is considered a necessary adjunct to every saw mill. They do not ship their lumber in the rough from the saw mills in Michigan, as we do here, but the lumber is planed and then shipped to all parts of the United States. Our lumber could be planed in the same way and manufactured, and

#### THIS WOULD GIVE EMPLOYMENT

to a great number of men. We know that it does not pay to ship the lower grades of lumber to the United States, because the duty is the same on all grades. Whether we have lumber worth \$25 a thousand or only worth \$7 a thousand the same duty of \$1 has to be paid, so it hardly pays to ship the lower grades of lumber to the United States. We could manufacture the lower grades of lumber here. Every one who knows anything about the lumber trade is aware that there is an immense market in the eastern States for the Ottawa Valley lumber and a large market in the Western and Central

States for the lumber manufactured on the Georgian Bay.

Lumber is cut 1 inch, 1-16 and 1-32 of an inch in thickness. When green it weighs 4,000 lbs. per 1,000 feet, partly dry from 3,000 to 3,500 lbs., and dry 2,500 lbs. per 1,000 feet. An average carload weighs 30,000 lbs., so that a car can carry 8,000 feet green, 10,000 feet partly dry and 12,000 feet of dry lumber. Lumber is generally shipped partly dry, that is, from two to four months after being cut. The freight varies with the distance and the lumber is graded differently in different localities. For the calculations I am going to make I intend to take the grading on the Georgian Bay, and also the freight from the Georgian Bay to Buffalo. At the present time, rough or unplanned lumber has to pay a duty of \$1 a thousand, planed lumber \$2 a thousand, and planed tongued and grooved \$2.50 a thousand, and lumber manufactured or partly manufactured 35 per cent. Thus the

#### DUTY ON PLANED AND MANUFACTURED LUMBER

virtually prohibits its exportation. To be properly planed the lumber must be dry, so that a car that carries 10,000 feet partly dry, as it is generally shipped, could carry 15,000 feet dry and planed, because we not only gain by reduced weight but by reduced thickness also. Lumber is planed on both sides to 7-8 of an inch thick for the eastern trade. Lumber in the rough is 35-32 of an inch in thickness, while after being planed it is only 28-32 of an inch, thus losing 1-5 of an inch in thickness, and consequently 1-5 in weight. So you will see that a car that will carry 10,000 feet partly dry will carry 15,000 feet planed and dried. The freight to Buffalo is \$35 a car, so that if we had reciprocity with the United States the lumbermen would save from \$7 to \$8 a car in freight alone, besides the duty of from \$2 to \$2.50 a thousand, which is a saving on the average of at least from \$32 to \$35 on every car we ship over and above the present profit, whatever that may be. Now, you can imagine what this would do for the city of Ottawa. Just fancy the lumbermen being able to save \$32 to \$35 on every car they ship over and above what they save to-day. They could afford to give better wages, to employ more hands. It is not necessary for me to tell you that not only Ottawa, but every town and every place in the Dominion of Canada where lumber is manufactured would flourish. Now, part of the lumber that is shipped from Georgian Bay is shipped to Buffalo and Tonawanda. The latter town has been built up by the lumber trade; in fact Tonawanda has been called the city of planing mills. A large portion of the Georgian Bay lumber is shipped there in the rough, and is planed and reshipped to different parts of the United States. I was in Tonawanda not a great while ago and while there the proprietor of a planing mill told me that he could plane lumber and ship it to Kansas and sell it cheaper than he could sell the same quality of lumber in the rough, simply on account of the extra freight on the rough lumber. In Tonawanda they employ 5,000 hands in planing and handling lumber. Just fancy

#### THE BOOM THAT WOULD TAKE PLACE

in our Canadian towns if these hands with their families could be distributed among them in working up this lumber. Of course you know Ottawa lumber does not go to Tonawanda, but is shipped in a different direction; but the Georgian Bay lumber goes, a portion of it, to Tonawanda, and if the towns and lumber districts of the west that shipped this lumber to Tonawanda could have the advantage of the residence among them of 5,000 hands with their families you can imagine what prosperity that would bring. There are thousands of dollars paid yearly on Canadian lumber in duty in the town of Tonawanda. It is not necessary for me to discuss the question of who pays the duty on lumber, because we all know that the lumbermen of this country pay the duty on every foot of lumber they send to the United States. Now, in speaking of reciprocity with Canada, this proprietor of a planing mill in Tonawanda told me that if they had reciprocity between Canada and the United States he would be compelled to move his planing mills from Tonawanda to the lumber districts of Canada within two years, because the extra freight on sawdust and shavings would be to him

#### A LITTLE FORTUNE.

Now, shipping culls, Georgian Bay grade, are worth \$7 per 1,000 at the mill; 1,000 shipping culls cut up and planed would make at least 500 feet of wainscotting. It would make a little more than 500 feet; but I wish to be on the safe side, and I will say 500 feet, although, as a matter of fact, it makes some 600 feet. Wainscotting is worth in Buffalo \$40 a thousand. The labor for making wainscotting costs \$1 a thousand. It takes 24,000 feet of culls to make 12,000 feet of wainscotting, worth at the mill \$168; cost of making, \$12. Now, the freight to Buffalo is \$33, the total amounts to \$213; 12,000 feet of wainscotting at Buffalo, at \$40 a thousand, would be worth \$480, so there would be a return for the shipper over the price of lumber and labor of \$267 a car. Now, then, take the article of doors. The ordinary four-panel stock doors are made out of what we call cut-ups and better, worth at the mill \$22. These doors are worth here \$1.50 wholesale, they are worth in Buffalo \$2.20 each; 1,000 feet of cut-ups and better will make

36 four-panel stock doors; 12,000 ft. will make 432 doors, or a car load 432 doors in Canada at \$1.50 each would be worth \$648; 432 doors in Buffalo at \$2.20 each would be worth \$950. Now, if we want to ship a car load of doors to Buffalo, we pay freight \$44 a car. I have in my calculation quoted freight at \$33 a car, but in shipping doors and manufactured lumber the freight is \$44 a car. Now, the duty on \$950 at 35 per cent. would be \$332.50, clearance paper \$3, total expenditure of shipment \$379.64. This, added to the \$648, the cost of the doors in Canada, makes \$1,027.24 as the total cost of delivering doors in Buffalo. But the doors in Buffalo are only worth \$950, so that the shipper actually loses \$77.24 on every carload of doors shipped to Buffalo. If we had reciprocity with the United States the shipper would get a return of \$77.24 on every carload over the cost of the door and freight.

#### QUITE ANOTHER THING.

**T**HE owner of a woodworking plant in these days finds himself compelled to pay far more attention to the administration of his business than was necessary a few years ago. When the woodworking machines were fewer in number and less efficient in work, the demand for wooden articles in every line outran the supply, making prices good and business generally remunerative. It used to be said that a man who failed in every other line could get rich in running a saw, shingle or planing mill. Those good old days have gone, and to-day, with the market crowded with countless high-grade and efficient machines turning out a supply greater than the demand, running a saw, shingle or planing mill, or a chair, coffin, waggon, excelsior, veneer, stave, heading, finish, frame, molding, crate, basket, bucket, tub, barrel or furniture factory is quite another thing. Twenty or thirty years ago the consumer pressed manufacturer. To-day the manufacturer is thrusting himself upon the consumer. The owner of a plant must make his wares, and then he must "hustle" for a market. This is the reason why the manufacturer of to-day spends more time in his office, over his books, than in his shop, over his machines. The machinery makers have wrought the great change visible in this line. The modern machines work so well and produce so much that supply has overtaken demand. The owner is succeeded in the shop by the foreman. The owner has become a mere administrator.

#### COST OF AN ACCIDENT.

**A**LUMBER case that created some general interest in the assize court, this city a week ago, was that of Martha Tobin, of Bracebridge against the Shannon Shingle Manufacturing Company, of Parkdale. William Tobin, husband of the plaintiff, was a joiner at the shingle factory and was killed there on November 1st 1890. The widow is left with five little children, the eldest only nine, and now sues to recover \$3,000 damage for the death of her husband on her own and their account. Tobin was getting \$1.75 a day as joiner, 25 cents a week being retained by the company as an insurance against accident. The claim alleges that the saw where Tobin was working was not guarded; while revolving at the rate of 1,350 revolutions a minute a block was drawn into it catching between the saw and adjacent machinery breaking a huge piece from the saw which flew at Tobin and cut through his body like a knife. He died about an hour after the accident. The defence is a denial of negligence on the part of the company, and denial of any defect in the machinery and an assertion that Tobin placed himself in the position occupied by him when he was hurt. Diagrams of the machinery used in a shingle mill were shown the jury, while Mr. Meredith, who is counsel for the defendants, had in court a pretty little model, said to be a fac-simile of the saw used by Tobin, all of which were used as matters of evidence. The verdict was rendered in favor of the plaintiff, the judge reserving his decision as to the exact amount of the award.

Have you a copy of the "Lumberman's Inspection Book"? It contains rules and regulations for the inspection of pine and hardwood lumber adopted by the lumber section and sanctioned by the council of the Board of Trade of Toronto, June 1890. Send a three cent stamp to the office of the CANADA LUMBERMAN and a copy will be sent you.



## THE NEWS.

### ONTARIO.

—Thomas Reaburn's mill at Perm is in full operation.

—E. C. Lewis, saw mill at Essex is doing a large trade.

—Parker's mill at Parkersville is still running and very busy.

—Smith Bros., saw mill and handles, Stewart, have sold out the handle business.

—The mill at Waubausene is shut down and the men have taken to the woods.

—John Charlton & Co. are operating 80 to 100 men on long timber in the Algoma section.

—A new road has been laid by the Western Lumber Co. near their offices at Rat Portage.

—The tug *Resolute* the property of the Emery Lumber Co., is to be rebuilt at Collingwood.

—The Gilmour Company will establish car works in connection with their business in Trenton.

—The paper wood that was hung up this spring in the Thessalon district is now coming down.

—Oct. 18th was the nineteenth anniversary of the laying of the first stone of the big mill at Deseronto.

—The Dickson Lumber Co., of Peterboro', have sold the remainder of their lumber to an Oswego firm.

—The lumber business of Mr. McDonald at Newton is showing every indication of a healthy growth.

—Woodstock has a soft maple tree, which shed its leaves some weeks ago and is now budding out again.

—A large force of men are at work on Fitzwilliam (Horse) Island, and a considerable cut is to be expected.

—A tow of six barges laden with lumber for New York and other American ports left Ottawa on 14th ult.

—Wages in the shanties this year range from \$18 to \$24 per month and board, a shade better than a year ago.

—Perley & Pattee, Ottawa, made a shipment of four barges of lumber and lath to Whitelake, N.Y., a few days ago.

—J. & T. Conlon's mill at Little Current, has shut down for the season. This firm are running two camps this season.

—Klock Bros.' limits in Wells township have been bought by Chew Bros., of Midland, and will be cleared this winter.

—About three hundred men will be employed in the Mickle-Dyment camps in the Gravenhurst section this winter.

—Fraser's mill in the Algoma district has closed down for the season. They hold a considerable quantity of lumber in their yards.

—Hugh Cameron, a shanty foreman, Ottawa, had \$300 stolen from his boarding house. Another boarder in the house is suspected.

—J. R. Booth's new mill at Ottawa is shut down for improvements and is hardly likely to get running again for this season's trade.

—Mickle & Dymont's mill at Barrie has closed for the season. The cut has been 6,000,000 feet of lumber and over 1,000,000 shingles.

—According to some old time river men the water in the St. Lawrence River a month ago reached the lowest point for thirty years.

—A large accumulation of sawdust in the river near Mansfield wharf, may yet seriously interfere with navigation around that portion of the Ottawa.

—J. S. Findlay, of Brooke, is building a new sawmill on the Center road, Keppel, to fill contracts he has for supplying maple blocks to a firm in England.

—Heath, Tait & Turnbull have started a camp in Bethune, and J. Whiteside, of Huntsville, intends putting a camp in the south-west corner of Proudfoot.

—Wm. McKinley, who stole a watch from John Bowles in Sloan's mill, Tilbury Centre, has been sentenced to one month's imprisonment in the county gaol.

—Ald. Scully, of Guelph, has been in Kentucky buying lumber for Charles Raymond's sewing machine factory, one of the profitable industries of the Royal City.

—The Wm. Mackay lumber concern of Ottawa, have recently completed a number of important repairs to their waterways on the Upper Ottawa tributary.

—A local paper says that within the past two weeks no less than 1,400 men went by North Bay to the vicinity of Wahnapiatae, to commence lumbering operations.

—The Rathbun Company, of Deseronto, has secured power from the Dominion parliament to borrow money to the extent of 75 per cent of the paid up stock of the company.

—The Collinsby Rafting and Towing Company are building a powerful steel steam tug at Kingston, the plates, machinery, etc., for which are being imported from England.

—W. R. Beatty and a gang of men are busily engaged building and repairing various dams in the Parry Sound district. The work is likely to keep them going until Christmas.

—Business is brisk at the sash and door factory at Deseronto. Many shipments are made to Great Britain. An annex of 60x16 feet will be erected to meet increased requirements.

—The Conger Lumber Co.'s mills at Parry Sound have closed for the season. The season's cut has been 8,000,000 feet. The company will get out a large number of logs this winter.

—Hollister & Jewell, of Garden River, whose lumbering property was destroyed by fire recently, have presented the fire brigade with a cheque for \$100 for the valuable services rendered.

—Reeve McCusker, of Prescott county, has secured contracts with Messrs. Bronson & Weston, Perley & Pattee, Hurdman & Co., and J. R. Booth for a winter's supply of hogs for the different shanties.

—Lumber shipments at Burk's Falls are reported to be heavy for the past month; these include lumber, shingles, lath, pulp wood and bark. The principal shippers are Jas. Sharpe, M. C. Drew, and Knight Bros.

—The Saginaw Salt and Lumber Co. are running three camps on the Vermillion and have a steam barge forwarding supplies from Nelson, on the Soo branch of the C.P.R. to Foster and the berth east, on which they are operating.

—David Sicklesteel, of Amherstburg, and two daughters will spend the winter at Vicksburg, Miss. Mr. Sicklesteel has a mill in that place, which will engage his energies. His business at McGregor will be managed by his son Lester.

—Manes & Booth, builders and contractors, Toronto, have assigned with liabilities about \$7,700, and assets consisting of equities in land and house properties worth \$16,500. With a slow real estate market the pressure of taxes and interests on mortgages was too much.

—Wm. Tyler, builder, of London, is endeavoring to effect a settlement with his creditors on the basis of 40 cents, secured. He owes \$10,000, and it is likely most of them will accept. He appears to have not figured his contracts out closely enough and to have lost money by taking them too cheap.

—The Hawkesbury Lumbering Company down the Ottawa have enough logs at their mill at present to keep them running nicely until cold weather sets in. A few days ago they sent an order to the Upper Ottawa Improvement Company's booms at Deschene's rapids to hold 50,000 there for them until next spring.

—McGibbon & Sons, of Sarnia, shipped a cargo of lumber to Germany. The cargo consisted of 300,000 feet of red oak, intended for furniture manufacture; it was shipped from their mill at Penetanguishene by the steamer Niagara, which delivered it in Quebec to a vessel which will land it in Antwerp. The freight amounted to \$5,525.

—The Pembroke Lumber Company has been incorporated under charter from the Dominion government. The leading stockholders are Andrew Thompson White, Arunah Dunlop, Peter White, Thomas Deacon, Cornelius Chapman and John Bromley. The capital stock is \$120,000, with power to increase same to \$240,000 by resolution of the shareholders.

—Howry & Sons have a large force on Whitefish River and expect to take out about twenty millions this next season. They have an "Alligator" tug which climbs portages from lake to lake and does the work of many men on the drive and in forwarding winter supplies on the inland lakes. It is of 30-h.p. and built by John West, of Simcoe, the inventor.

—A Sudbury correspondent writes that the camps in that section are running to their full capacity, with the exception of A. McCormick & Son, who are desirous of disposing of their limits and do not intend to run a camp themselves. Some building is going on in Sudbury and quite a few buildings on the Soo branch railway for the Chicago Nickel Co.

—Two shantymen Chanor and Duchesne had a narrow escape from going over the Cascade rapid: up the Gatineau. They had allowed the craft to drift with the current, until it got beyond their control and was within fifty yards of the waterfall. Fortunately at this point the boat stuck fast on a rock, where the men remained until daylight when assistance arrived.

—\$150,000 worth of timber limits are involved in the case of Moore vs. Moore, which is now on the docket in the Master-in-Chamber's court at Osgoode Hall. The Moores come from Ottawa. Not long ago David Moore, a wealthy timber limit man died there, leaving no will; and his son,

Edward D. Moore, who had been manager of the timber interests, possessed himself of this property, and the other brothers, Charles A. and Fred. D. Moore, brought an action of ejectment against him. The case is also in the Quebec courts, and the motion at Toronto is for a stay of the injunction until the first case is decided.

### QUEBEC.

—End, Trihey & Co., lumber, Montreal, have dissolved.

—Richard Ready, coal and lumber, Montreal, has assigned.

—Moore & Eady, of Bryson, have large gangs of men at work on the Schyan.

—David Lunam, of Campbell's Bay, is at the shanties on the Madawaska with a large gang of men.

—The decrease in the timber exports this season as compared with last will show a falling off of about thirty per cent.

—The four great driving pulleys for Eddy's new mill at Hull will measure 7 ft high, 4 ft. wide and two inches thick on the flange. Each of them will transmit power equal to 400 horse.

—The Buckingham Manufacturing Company (limited,) with a capital of \$80,000 has been incorporated, a number of Montrealers being the promotors. Their objects are to deal in wood pulp paper.

—Mrs. Bondu, who lives near Lac du Sable, charges a number of shantymen with stealing her whiskey, breaking her bottles and doing lots of other mischief. The magistrate when appealed to for redress gave the woman the very sensible advice to go home and give up selling whiskey.

—According to figures published by the Quebec Government it is estimated that there have been produced in the province during the twenty-three years from 1857 to 1880 inclusive, 11,173,516,546 feet of lumber, and 70,272,572 cubic feet of timber, while \$10,764,368 have been paid over to the government as timber dues.

### NEW BRUNSWICK AND NOVA SCOTIA.

—About one hundred men are in the woods at Clearwater, N.B., for Mr. Lynch.

—Richards & Co., of Boieston, N.B., will have three camps this winter on Burnet Land Brook.

—Stevens & Roman are two young men from Acadia Mines who started a small saw-mill four miles from Spring Hill, N. S., on some money advanced by the father of one of the partners. Their next step was to give a bill of sale for \$759 covering the engine, boiler and plant, and this they have followed up with an assignment.

### MANITOBA AND THE NORTHWEST.

—Ross, Hall & Brown, of Rat Portage, Man., have closed down for the season.

—The Safety Bay Lumber Co. (Bulmer's mill) cut 57,000 feet of lumber in one day with Howard Vanderburg presiding at the circular.

—Cameron & Kennedy, of Norman, Man., have been running their mill day and night throughout October. They have sent a large gang of men to the woods for the winter's work.

### BRITISH COLUMBIA.

—A new logging camp will be established by the Brunette Saw Mill Co., near Pitt River.

—The Spicer mills, at Vancouver, are at present giving their entire attention to sawing shingles for the Manitoba trade.

—S. F. McIntosh and J. W. Enland, lumber dealers, Victoria, have dissolved partnership. Mr. S. F. McIntosh will continue the business.

—C. L. Street & Co., of Chilliwack, have lately purchased from Mr. B. A. Irwin, a former resident of Markdale, Ont., the standing timber of 100 acres for \$2,700. The timber is comprised mostly of red fir, silver fir, cedar, hemlock, spruce, alder and maple. A limit of five years is given the above firm to remove the timber.

—J. M. Stewart, formerly Chief of Police at Vancouver, who does a great deal of logging for the Brunette Saw Mill Co., has just completed fitting up a portable logging camp on Burrard Inlet, which will add much to the comfort of his men while engaged in the woods. It consists of a one storey house constructed upon a scow. It is fitted up with bunks for eight or ten men, and a separate room for Mr. Stewart himself. The galley for cooking is well supplied with the required utensils. One end of the scow is fitted up for the reception of the logging engine which is placed there for transportation. While aboard, however, its power can be used for the side wheel paddles with which the scow is supplied. The outfit also contains a blacksmith's forge, anvil, vice and other tools required to make ordinary repairs.



## Foreign News Items

- Russia makes 30,000,000 wooden spoons a year.
- Mexico's new tariff law retains lumber on the free list.
- Winds have blown down about 80,000,000 feet of timber in northern Minnesota.
- W. H. Sawyer, a lumber dealer of Buffalo, N.Y., has made contracts with Ashland mill owners to saw 80,000,000 feet of lumber.
- The Montreal Lumber Company has bought 1,200 acres in Ashland County and 200 in Michigan.
- More than 187,000,000 feet of lumber have been received at Buffalo, N.Y., since the opening of navigation.
- Men are so scarce in Michigan that in order to get them to go into camp they have to be obtained from the ranks of sewer diggers and other day laborers.
- More than 15,000,000 feet of lumber will be used in the construction of the huge building for Manufactures and Liberal Arts at the World's Fair, Chicago.
- Nearly 2,500,000 feet of lumber was shipped by rail by the Saginaw Lumber and Salt Company during September. Rail shipments have been active all along the line for the past month.
- The whole State of Maine is experiencing a severe drought and typhoid fever is raging in many towns. The cotton mills at Waterville and Augusta and the sawmills along the Kennebec are seriously retarded.
- In France the government still levies a tax on doors and windows. To the peasant in his small hut this tax amounts to a little more than 60 cents a year, but in small towns it rises to \$3.40 annually for each family.
- It is reported that a Michigan hardwood concern has exhibited at a county fair thirty varieties of wood cut from a single acre of ground. If this be the case, and the trees are of any use, this concern ought not to be obliged to shut down for want of something to cut.
- The H. C. Akeley Lumber Company, the largest manufacturers in Minneapolis, had sold within 6,000,000 feet as much lumber as they had made up to the first of October. Secretary Jones and E. L. Harkness expect that October sales will aggregate 10,000,000 feet a month.
- The Grounds and Buildings Committee of the World's Fair, Chicago, have decided to advertise for the construction of a building to accommodate four sawmill plants. The structure will be located south of the agricultural annex, on piles driven in what is now a natural lagoon. The building will be 130x200 feet and will cost \$25,000.
- And now comes the proposition to build two railroad cars out of a big tree found in Tulare, Cal. The log is to be made hollow, windows and doors will be cut, and the interior will be handsomely finished. The cars will be 45 feet long with a diameter of 20 feet. They will be exhibited at the World's Columbian Exposition.
- It is reported from Duluth that Michigan lumbermen who are interested in timber in the Duluth district expect to perfect arrangements with the Duluth & Winnipeg and St. Paul & Duluth railways to bring logs to Duluth by rail. It has not been found practical to get the logs by the Knife Falls Boom Company's boom at Cloquet and down the St. Louis river, which is always an uncertain stream.
- Maine lumbermen are making preparations for their winter's logging and will commence work promptly with the advent of cold weather. It is said the cut will be somewhat less than that of last season, but it is probable that each lumberman will let his neighbor do the curtailing and put in an average cut himself.
- The foreign lumber business it is evident is still very much demoralized. A meeting of the saw mill owners' society of Sweden was recently held at which thirty mill owners were present at which an agreement was reached to reduce the mill cut one-half. A proposition was also made to reduce the time of credit to English buyers from six months to four months. Under these conditions it is believed that the market will be very much strengthened. The sawmill owners are to open negotiations with the Swedish banks and endeavor to induce them to discount no bills drawn for a longer period than four months.

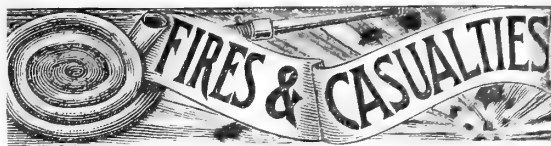

### FIRES.

- An old saw mill owned by J. W. Dinwoodie, Campbellford, Ont., was burned recently.
- An incipient fire occurred in Fredett's lumber yard, St. John, Que. Little loss occurred.
- Mather's saw mill near Vancouver, B.C., was completely destroyed by fire first week of October. No insurance.
- Chew's mill at Gravenhurst, Ont., was burned to the ground on 14th ult. The lumber was saved. Loss, \$12,000. Insurance, \$8,000.
- An old church at Seaforth, Ont., stored with lumber and egg cases by D. D. Wilson was burned on 6th ult. Insurance \$1,000—incendiary.
- A fire occurred at Leg Lake, Ont., on 15th ult., destroying the Deblaqueir mill and about one and a half million feet of lumber and 200,000 shingles.
- Moffat's steam saw mill at Dalhousie, N.B., was burned the other night together with a large quantity of lumber. The loss is about \$25,000 and no insurance.
- The large box factory at Waubashene, Ont., owned by the Dodge & Bliss Box Company, Jersey City, was destroyed by fire on 21st ult. Loss about \$25,000; insured.
- The workshops and mills of the Canada Lumber Cutting Machine Company, at Trenton, Ont., were destroyed by fire on 21st ult. A quantity of hardwood lumber was also burned. Property insured for \$31,200.
- A destructive fire occurred in Halifax, N.S., the early part of the month. Among other properties destroyed were Brookfield's lumber wharf, J. C. Merlin's planing mill, Brookfield Bros.' lumber warehouses and office, and Mulcahy's cooorage.
- The large planing factory at Uxbridge, Ont., owned by R. P. Harman and operated by Reid & Thirsk, was totally destroyed by fire on 9th ult., together with machinery and contents. Harman's loss is fully \$5,000 and Reid & Thirsk's about \$6,000. No insurance.

### CASUALTIES.

- John Watts, working in a Kingston saw mill had his leg broken by a falling log.
- A circular saw removed parts of two fingers of W. R. Davey, Williamsworth, Ont.
- Joseph Dauphin had a finger badly cut with a saw in Sicklesteel's mills at McGregor, Ont.
- J. Johnsen, of Magog, Que., had his head badly cut by coming into contact with a circular saw.
- Antoine Merault, an old river man, of the Ottawa, had two ribs broken near the Deschenes rapids while booming logs.
- Wm. Crowe, of Dummer, Ont., lost a son by a falling tree in the Parry Sound Lumber Co.'s camp the early part of the month.
- The right hand of F. A. Clark, of Berwick, N.S., is badly lacerated through coming in contact with a saw while at work in the mill.
- Thomas Boulanger is in the hospital at New Westminster, a victim of a broken leg, caused by a log falling on him while at work in the woods.
- Wm. Johnson, a river man has come down from the Kippewa to Ottawa, Ont., suffering with a fractured leg, sustained by a tree falling on him.
- A young man named Wm. Graham, working in Bryce's shingle mill, Penetanguishene, Ont., got caught in a shaft and had an arm broken and his face badly bruised.
- A Frenchman working in the Fullerton lumber district, near Masonville, Que., was killed a few days ago by a falling tree, and a comrade with him was seriously injured.
- David Esdale, an employee at McLaren's mills, Ottawa, Ont., dislocated his wrist, broke his arm, and seriously injured his right foot, while moving lumber at the mills.
- James Watson, an employee at Moore's planing mill at St. Mary's, Ont., met with an accident the other day, by which he lost part of the thumb and the three fingers of his right hand.
- F. Plastow, son of Mr. Plastow, while working around Mr. Roach's stave factory, at West Lorne, Ont., slipped and coming in contact with the knife, had the ends cut off two fingers of the right hand.

A 12-year-old daughter of Joseph Bourdeau had the misfortune to cut off the first and second fingers of her hand Sloan's mill, Tillyary Centre, Ont., while foobing with the stave jointer.

Clark Jones, jr., of Glen Sutton, Que., who was cutting logs, cut his foot severely a week ago. Willur Richardson, of the same place, was severely injured by falling from a log while chopping.

The careless use of an axe in the hands of a young son of F. A. Haystead, of Fielding, Ont., has brought severe injury to the foot of this lad. He was at work in the woods in the Parry Sound district.

A shantyman, Jacques Granbois, D'Amone camp, has returned to Ottawa, Ont., suffering from a fearful accident with a sharp axe he was wielding. It is feared the limb will have to be amputated.

A shantyman named St. Croix, while on the way to the station in Ottawa on 23rd ult., was thrown from an express wagon by a broken street car rail, and received an ugly cut on the head.

A frightful accident happened on 10th ult., near Spanish River, about one-half mile east of Shea's Hotel, in which one Robert Quigley, lumberman, was cut to pieces by a freight train. The unfortunate man was supposed to have been under the influence of liquor at the time of the accident and had not noticed the approach of the train.

Robert O'Rourke had his hand cut in the cedar mill at Deseronto, Ont., and Edward Bruyca, while working in the big mill, the same day had the index finger of his left hand badly lacerated. Heber Winfind had two fingers badly crushed at the sash factory. So much for Deseronto, Ont.

Accidents have been numerous in the Eddy mills at Hull, Que., during the month. A young man named Guertin, aged 15, had two fingers severed from his right hand by the steam rollers of a paper machine. C. Miller, another employee in the paper mill caught his arm between two large iron rollers and had it terribly lacerated. Jacques, a youth of 17, sustained a severe scalp wound by the breaking of a pulley in the saw mill.

A budget of accidents is reported from Mickle & Dyment's camps in the Bracebridge district. Abraham Vanwicklin nearly lost a thumb and is in the hospital. Fred Sawyer, another workman, is keeping him company with a bad gash in his shin made by an axe. John O'Neil was struck over the back with a large limb broken by the storm. He died while being carried to Huntsville by his companions. Wm. Clevely is in the hospital at Huntsville and may not recover. He was at work in the camp near Dorset and was going to another camp to see his brother, and travelling along the road was mistaken for a deer by a hunter and was shot, the ball striking near the shoulder and travelling through his body.

### TRADE NOTES.

In our September issue, in giving a short description of a new two-spindle boring machine just constructed by the Cant Bros. Co., of Galt, Ont., instead of saying "The range of adjustment is from a horizontal to a perpendicular," it should have been "The range of adjustment is from a horizontal to a perpendicular line, and to 45 degrees beyond the perpendicular."

A notable exhibit at the late Montreal exhibition, was that of Robin & Sadler's in the machinery hall. One of the chief attractions of this exhibit was a pyramid consisting of three large leather belts made for W. W. Ogilvie's flour mills; these were 24 in., 18 in. and 16 in. belts respectively. Messrs. Robin & Sadler had also on exhibition a 26 in. belt which was awarded a gold medal at the Jamaica exhibition. Besides these were to be seen some very fine specimens of the dynamo belting this firm make a specialty of.

The Brazil Snow Plow, manufactured by J. Muckleston & Co., Kingston, who control the patent for the Dominion, bids fair to be soon used by all our lumbermen who have limits to operate. Although this firm only lately commenced manufacturing them the following lumber firms have already placed orders for plows: McLachlin Bros., 6; McKeon & Glover, 3; Barnet & McKay, 1; Georgian Bay Lumber Co., 2; Thistle, Carswell & Co., 1; Bronson & Weston, 2; Perley & Pattee, 4. Satisfactory orders have also been received by the Messrs. Muckleston for cant dogs, peavies, etc. As this establishment is the only one in the Dominion turning out a complete outfit of lumbermen's plows, sleighs and tools, it is unique in its character and we trust will receive liberal support.

TRADE REVIEW.

Office of CANADA LUMBERMAN.  
Oct. 31, 1891.

THE GENERAL SURVEY.

CANADIAN lumbermen are in good feather. This is despite the fact of more local failures during the month than for probably any single month in the year. These have in no measure, however, disconcerted the general trade. They comprise chiefly builders of speculative properties in the city, men who could keep their heads above water so long as the real estate boom was on, but with whom it was only a matter of time of going under, as soon as the bottom fell out of real estate. Though, in numbers these embarrassments have not been few, none have been for large amounts, with the exception of William McBean, whose liabilities are about \$250,000. This amount consists nearly altogether of mortgages on properties, the unsecured claims not exceeding \$10,000. For some time back the insolvent's building operations have been almost nil. A proposition of twenty-five cents on the dollar has been made to the unsecured creditors, and is likely to be accepted.

Country trade has not opened out as was expected a month ago. Reports from western Ontario tell of a quiet trade, yet the expectations are well founded that the year's work among the farmers completed, and the grain to some reasonable extent marketed, a satisfactory business will be done. No disturbing elements have a place with country dealers.

The chief cause of hopefulness with the trade is the impetus that has been given to American trade during the month. Said the head of one large concern, and we found that the same view was entertained by wholesalers generally, "lumber trade with the States is undoubtedly looking up. The demand for dressing and better is in excess of the supply. Truth is that we have very little of these grades unsold at any important lumber point in the province. This is having the effect of making prices unquestionably firm and foreshadows a promising trade for the spring." One firm holding a large quantity of Canadian lumber is Shepherd & Morse, of Boston, and they realize that they have a good thing to hold. A few days ago a request came from an Albany house to be put in communication with any one having 1 1/4, 1 1/2 and 2 in. wide sidings 12 and 16 ft. cutting up and better, but no one could be found to meet the call. Briefly stated Canadian lumber will be at a premium in the near future. Coarse grades are a little slow, yet the scarcity of better is causing a demand for these in places where dealers must have something. A good trade is being done in hardwoods. The Ottawa strike is over, and the mills are making the most of the short season left them. Conditions in the maritime provinces, Manitoba and British Columbia, also United States and foreign markets are reviewed at length further on in this paper.

NEW BRUNSWICK.

No big boom is on in this province. Shipments in spruce deals to Great Britain for the month ending September 30th have been slightly in excess of the corresponding month last year. Trade with the States has been only fair. The total value of exports of the products of the forest from St. John during September shows an increase from \$190,190 to \$245,654 as compared with the corresponding month last year. Attention is being given just now to the winter's work in the woods which is likely to show an average cut.

MANITOBA.

The trade are somewhat stirred up over a circular issued by the Pine Lumbermen's Association concerning spruce lumber. The pine lumber manufacturers have found that the demand for high grade stuff, such as ceiling, siding, and flooring, has been in excess of the demand for common dimension stuff and common boards. This has been caused by the fact that many retail dealers handle spruce lumber for common stuff, and take pine for their high grades. This has left the pine men with a large surplus of common stuff on their hands. A circular was accordingly sent out by the association lumbermen that they would not sell to any retailer who handled spruce for low grades. As the

retailers must have pine for best grades, they would be forced to take pine for common stuff also. The matter has been referred to in our editorial columns, showing that not only has the spruce men been up in arms, but that the local board of trade have had the question under consideration, resulting in a resolution vigorously protesting against this action of the Pine manufacturers. The Winnipeg Commercial says that "the men certainly have ground for complaint, but they evidently have made a mistake in the way they have undertaken to remedy the difficulty." The operations are about an average for the season of the year. The Lake of the Woods lumbermen are busy getting their camps in ship shape for the winter's work. The business of the Lake Winnipeg Lumber and Trading Company is being liquidated.

BRITISH COLUMBIA.

The month has closed with conditions in lumber not by any means discouraging. A good local trade has been done, and the exhibit made at the annual exhibition, referred to in our British Columbia news letter, indicates some of the possibilities of the province in manufactured lumber, as well as telling something of the natural products of our forest. A fair trade with Australia continues to show up from month to month. Several good sized shipments were made during October, and on the 10th inst. the bark *Pisagua* sailed from the Moodyville mills for Pisaga, Peru, on owners account. The freight market is unchanged, and dullness prevails at 57s 6d. Quotations are as follows for cargo lots for foreign shipment, being the prices of the Pacific Pine Lumber Association: Rough merchantable, ordinary sizes, in lengths of 40 feet, inclusive, \$9 per M feet; rough deck plank, average length 35 feet, \$19; dressed flooring, \$17; pickets, \$9; laths, 4 feet, \$2. For local trade, the Rock Bay Saw Mill quotes: Rough lumber, per M..... \$10 00  
Best quality dressed lumber, per M..... 20 00  
Second " " "..... 17 00  
Lath, per M..... 2 50  
Shingles "..... 2 25

Recent official returns show that the revenue received from the British Columbia crown timber agency during the last year was \$45,485.09, an increase of \$27,440.32. The total quantity of lumber manufactured for the year amounted to 13,546,943 feet as compared with 23,759,942 feet for the last year, and sold at the rate of \$9 to \$10 a thousand.

UNITED STATES.

We doubt if on the whole reports from leading lumber circles in the States tell of as satisfactory lumber trade in October as for the preceeding month. This is perhaps to be explained by the fact that we are one month nearer the close of the season than was the case thirty days ago. Besides the contrast between the opening of fall trade in September with the dullness of the summer months just then ended was more noticeable than a contrast between October and September trade; lumbermen like other mortals are influenced by their impressions. Buffalo and Tonawanda, as a point in which Canadians are interested, sends a good decent growl of dull times, and so does New York, and no one at these points looks for a change before the opening of spring. The situation is like this: Trade in certain rural sections, observably in the State of Ohio, is brisk, especially in white pine. Farmers have secured abundant crops, and they are spending their money in improvements. But the benefits of a rich harvest are not being experienced in the great centers of population. There was too deep an impairment of confidence in all forms of investment, as a result of last fall's panic, for that. Real estate had received a severe setback, and it will take some time for it to again reach the speculative stage. Credits were seriously impaired by several important failures. Investments that promised well last year turned out badly, and recovery must be made from loss. Liquidation must reach farther than it has yet before capital will again venture to take risks. But it can be seen that the process is going on, and by the beginning of next year or in the early spring we may expect to see all forms of enterprise take a fresh start. Then will come an extraordinary demand for lumber from the railroads, from the cities and towns and from the developing west. Quite an export trade has been

done from Puget Sound, Washington, and the Humboldt regions of California. One report chronicles a big sale of lumber from California, a contract having been closed in San Francisco recently for the shipment of 20,000,000 feet of lumber to South Australia for the use of the Broken Hill Mining Company. This is the largest shipment ever ordered for a foreign market from the Pacific Coast. Bids were put in for it by a number of Puget Sound mills, as well as California concerns, but it is not yet announced who was successful in securing the contract.

FOREIGN.

"There has been a perceptibly improving tone in most branches of the trade during the past month" say Denny, Mott & Dickson, of London, Eng., in their October wood market report, "and there are appreciable indications to justify the expectation of better business during the closing months of the year, beyond the consideration that newly-spread confidence often serves to bring about the improvement hoped for. We trust that these hopes may be realized and that the last quarter of the year may do something to redeem the character of what has hitherto proved one of the most disastrous years within the experience of the trade." Messrs. Churchill & Sims, London, in their wood circular of October 5, give these figures:—From Canada the importation has been—Pine deals, 971,000 pieces, against 2,189,000 pieces in 1890; spruce deals, 872,000 pieces, against 1,499,000 pieces in 1890. And from New Brunswick—Spruce deals, 167,000 pieces, against 98,000 pieces in 1890. They add: The consumption of pine deals in September has not quite equalled that of last year; but the position is very healthy, mainly in consequence of an importation of less than half of the great quantities brought to London in 1890. This has reduced the stocks to not much more than those of 1888 and 1889. Spruce deals have also been sparsely supplied, and, the stock being now in quite average compass, prices have risen during the month and holders are very hopeful. Hardwoods have been a little more in demand." The great carpenters and joiner's strike at London, which has been on for the last six months and has cost upwards of a quarter of a million of dollars, has at last been settled by arbitration and the men have gone to work. Though late in the season this will have an influence for the better over local trade. The Liverpool *Timber Merchant* reports that owing to the falling off in American shipments of walnut and whitewood, more business has been done at the yards, demand running chiefly to the better qualities. Stocks of inferior descriptions are still much too heavy. Stocks of pitch pine lumber are large, and prices are low. Stocks of Quebec oak logs are heavy, but recent arrivals of plank and scantling have gone immediately into consumption. Several parcels of Montreal deals arrived during the latter part of September, the bulk of which also went into consumption. High freight rates have made prices firm, and the tendency is toward advance. The demand for third quality deals is very good, and the stock is small, consequently a rise in price is looked for. There are several arrivals in spruce deals. Prices generally were firm, and favorite sizes brought excellent figures. "Flooring boards" were reported in reduced supply, there having been no recent arrivals, some sizes and qualities being entirely wanting. African mahogany has become a serious competitor in the English market, of Honduras, Tobasco and Mexican mahogany selling readily at high prices, and being, seemingly, as well liked by consumers. In Sweden trade has been greatly hindered by the continuance of the strikes in the joinery and allied trades. Activity is reported in the Australian trade, considerable shipments being made from the Pacific coast to this point.

Toronto, Ont.

TORONTO, Oct. 31, 1891.

CAR OR CARGO LOTS.

1 & 1 1/2 in. Cut up and better.....	32 00	33 00
1x10 & 12 dressing and better.....	18 00	20 00
1x10 & 12 mill run.....	13 00	14 00
1x10 & 12 dressing.....	14 00	15 00
1x10 & 12 common.....	12 00	13 00
1x10 & 12 spruce culls.....	10 00	11 00
1x10 & 12 mill culls.....		9 00
1 inch clear and picks.....	24 00	25 00
1 inch dressing and better.....	18 00	20 00
1 inch siding mill run.....	14 00	15 00
1 inch siding common.....	11 00	12 00



Table listing lumber products such as 1 inch siding ship culls, 1 inch siding mill culls, and various shingles with their respective prices.

YARD QUOTATIONS.

Table listing yard quotations for mill cull boards, shipping cull boards, and various types of flooring and shingles.

Ottawa, Ont.

OTTAWA, Oct. 31, 1891.

Table listing lumber prices in Ottawa, Ontario, including pine, ash, and lath.

Montreal, Que.

MONTREAL, Oct. 31, 1891.

Table listing lumber prices in Montreal, Quebec, including pine, spruce, and hemlock.

St. John, N. B.

ST. JOHN, Oct. 31, 1891.

Table listing lumber prices in St. John, New Brunswick, including spruce, pine, and shingles.

New York City

NEW YORK, Oct. 31.—Indications tell that we are drawing to the close of the season's business. Many of the transactions of the month have this cleaning up character.

White Pine—Western Grades.

Table listing prices for white pine in Western grades, including various sizes and types of lumber.

Albany, N. Y.

ALBANY, N. Y., Oct. 31.—Whatever may be the mood of lumbermen elsewhere, seldom have the craft here been in more jubilant spirits. They are full of business and getting plenty to do.

White Pine.

Table listing prices for white pine in Albany, including various sizes and types of lumber.

Thirteen Foot Stock Boards and Plank.

Table listing prices for thirteen foot stock boards and plank in Albany.

Shingles and Lath.

Table listing prices for shingles and lath in Albany.

Buffalo and Tonawanda, N. Y.

TONAWANDA, Oct. 31.—Lumber business is emphatically dull, that is the long and short of it. We are not getting any so-called fall trade worth the name, nor are our people looking forward to a change this side of spring.

White Pine.

Table listing prices for white pine in Buffalo and Tonawanda, including various sizes and types of lumber.

Box.

Table listing prices for box lumber in Buffalo and Tonawanda.

Shingles.

Table listing prices for shingles in Buffalo and Tonawanda.

Lath.

Table listing prices for lath in Buffalo and Tonawanda.

Oswego, N. Y.

OSWEGO, N. Y., Oct. 31.—An increased demand has taken place for box grade also cutting up and better, making prices in these lines rather firmer.

White Pine.

Table listing prices for white pine in Oswego, including various sizes and types of lumber.

Siding.

Table listing prices for siding in Oswego.

1x12 Inch.

Table listing prices for 1x12 inch lumber in Oswego.

1x10 Inch.

Table listing prices for 1x10 inch lumber in Oswego.

1-4x10 Incher.

Table listing prices for 1-4x10 inch lumber, including mill culls and dressing.

Shingles.

Table listing prices for shingles, including various types and sizes.

Lath.

Table listing prices for lath, including various types and sizes.

Saginaw, Mich.

SAGINAW, MICH., Oct. 31.—No special activity has marked business during the month, and some hold to the old story that trade is dull. At the same time a good deal of lumber has changed hands, the past week.

Finishing Lumber—Rough.

Table listing prices for finishing lumber in Saginaw, Michigan.

Siding.

Table listing prices for siding in Saginaw, Michigan.

Timber, Joist and Scantling.

Table listing prices for timber, joist, and scantling in Saginaw, Michigan.

Shingles.

Table listing prices for shingles in Saginaw, Michigan.

Lath.

Table listing prices for lath in Saginaw, Michigan.

Boston, Mass.

BOSTON, MASS., Oct. 31.—Business has been fair throughout the month, without any special circumstances to be noted. Quotations remain unchanged.

Western Pine—by car load.

Table listing prices for western pine in Boston, Massachusetts.

Eastern Pine—Cargo or Car Load.

Table listing prices for eastern pine in Boston, Massachusetts.

Spruce—by Cargo.

Table listing prices for spruce in Boston, Massachusetts.

Lath.

Table listing prices for lath in Boston, Massachusetts.

Shingles.

Table listing prices for shingles in Boston, Massachusetts.

The following vessels are now due at B. C. ports to load lumber at Hastings or Moodyville Mills: The Norwegian bark Floar, 776 tons, from Australia; German ship Elsie, 1,348 tons, from Sydney; German bark Kalinka, 876 tons, from Rio de Janeiro; Chilean ship India, 1,054 tons, from Valparaiso, and the Chilean ship Glenmoray, 1,235 tons, from Valparaiso.

LUMBER WANTED.

WANTED for cash immediately, about 150,000 feet ash, bill stock, prime quality from 9 to 18 feet long, 15 to 18 inches wide, 1 1/2 to 6 1/2 inches thick. Quote price f.o.b. New York. Will submit dimensions upon request. Address P.O. Box 2144, New York, N.Y.

## MICHIGAN LETTER.

American Lumber Operations in Canada—Sketch of Two Big Firms—Transfer of Valuable Ontario Limits—Michigan Lumber Items.

[Regular correspondence CANADA LUMBERMAN.]

CANADIAN lumbermen are not without a lively and appreciative interest in American lumber affairs. Much of your lumber, under any circumstances, is sold on this side of the lines, and of late this trade has been steadily increasing. I need not tell you that Michigan lumbermen have a special concern in Canadian lumber, not a few of her citizens being among the largest operators of timber limits in the Province of Ontario. Among the larger of these firms are the Saginaw Lumber & Salt Company and the Emery Lumber Company, both of Saginaw, Mich. I have thought that it may not be without interest to your people to learn something of the personal composition and financial strength of these concerns.

The Saginaw Lumber & Salt Company dates its existence from 1881, when it was capitalized at \$120,000, with a surplus of \$200,000. The president of the company is one of your own citizens, James McLaren, the well known lumberman of Buckingham, Que. R. A. Loveland, of Saginaw, Mich., is vice-president; R. H. Roys, of Saginaw, secretary; D. L. White, jr., treasurer. The head offices are located here, with Mr. Loveland and Mr. Roys as managers. Mr. Loveland is a New Yorker, born at Westport in that State in 1819, and has followed lumbering all his life. He was for several terms a member of the New York legislature. The mill owned by the company was formerly that of Sibley & Beringer, Crow Island, just out of the city. They manufacture 20,000,000 feet annually. The company owns 70,000 acres of stumpage in the Georgian Bay district, and the coming winter will put 15,000,000 feet of logs into the Vermillion river, and about 5,000,000 feet will be cut on Fitzwilliam Island. These logs will be rafted to the company's mills here next season. Mr. Loveland took an active and influential part in securing in the McKinley bill the clause reducing the tariff on Canadian lumber imported into the United States, upon the repeal of the Canadian log export duty.

The Emery Lumber Company was organized in 1885, with a capital stock of \$120,000 increased in 1889 to \$180,000. The officers are the same as those of the Saginaw Lumber & Salt Company. This company owns a mill at Midland, Ont., having a capacity of 18,000,000 feet, but it has not been operated during the season of 1891. It stocks the mill of Temple Emery, at East Tawas, and also furnishes stock for N. Holland's mill in Saginaw, as well as some logs for the Saginaw Lumber & Salt Company. During the present year it has handled about 40,000,000 feet of logs and has camps established on the Wahnapiatae, under the direction of Thomas Pickard, an old Michigan logger, who expects to cut 40,000,000 feet of logs during the season of 1891-2 for the supply of the mills next season. This company also owns 70,000 acres of timber in the Georgian Bay district.

These same lumbermen are organized into another corporation known as the Michigan Log Towing Company, with a capital of \$75,000. It owns and controls five large tug boats, and brought across the lake from Canada the present season 40,000,000 feet of logs.

## OTHER OWNERS OF CANADIAN LIMITS.

An important sale of Canadian timber was closed here on 3rd inst., when Ring & Merrill, of this city, who some time ago purchased from the Midland & North Shore Lumber Co., of your country, valuable timber limits in the Georgian Bay territories, sold these limits to Wm. Peter, Columbiaville, Lapeer Co., the millionaire lumberman. The property it is believed contains nearly 300,000,000 feet of pine timber and the consideration is reported at about \$350,000. Mr. Peter buys the lumber to stock his Bay City mill, which means, of course, that the logs will be towed to this side of the line.

Sibley & Beringer, of this State have started two camps in the Georgian Bay district. They will put in about 6,000,000 feet, and have hung up for another season, 2,000,000 feet. Mr. Beringer is disposed to grumble at the price of stumpage in the Georgian Bay, and thinks it will be a barrier to future buying.

## MICHIGAN LUMBER NOTES.

Freights have advanced 25 cents per thousand, the rate now being as follows: From Bay City to Buffalo and Tonawanda, \$1.75; to Ohio ports, \$1.50; from Saginaw to Buffalo and Tonawanda, \$1.87½, and to Ohio ports, \$1.62½. This rate may be further increased shortly.

Rodney has had a fire, which wiped out \$25,000 worth of hemlock lumber.

The Tittabawassee Boom Company is forging toward the 275,000,000 feet limit, which it was predicted would be their output this year.

S. G. M. Gates, who runs one of the best mills on the Saginaw river, will save a big towing bill by having over 1,000,000 feet of logs transformed into lumber up at Cheboygan.

As high as \$28 per month is being paid experienced men for logging operations.

H. W. Sage has purchased the Emery mill property at East Tawas, consideration \$12,500.

C. K. Eddy & Sons, East Saginaw, have purchased a berth on the White Fish river, on the north shore of the Georgian Bay.

An estimate of the logs rafted and delivered the present season is as follows:

	Feet.
Tittabawassee and tributaries.....	295,000,000
Cass river .....	6,000,000
Bad river.....	3,000,000
Kawkawlin.....	5,000,000
Rifle river.....	25,000,000
Au Gres river.....	15,000,000
From Georgian Bay.....	80,000,000
Upper Michigan points.....	35,000,000
Total.....	464,000,000

PICA.

SAGINAW, MICH., Oct. 24, 1891.

## OTTAWA LETTER.

Conclusion of the Strike—What has been Accomplished—The Trade Side—Other Matters.

[Regular Correspondence CANADA LUMBERMAN.]

THE great strike is ended. The mills are not running with as large a staff of men as formerly, for the reason that the men are not here. Not a few found employment elsewhere during the progress of the strike and left the country. To this extent the ranks are broken.

Do you ask what has been accomplished by the strike? It is about as THE LUMBERMAN has put it, "Strike but Hear." The mill men of their own volition have made the rate of wages the same as they had been in 1890, that is 50 cents a week increase over what they were getting this year. No reduction has been made in the number of working hours per day, except in the case of Buel, Orr & Hurdman, where the ten-hour system has been adopted, but unaccompanied with any promise of an increase of wages.

The outcome can hardly be deemed a satisfactory one for the strikers. They have lost a month's work and consequently a month's pay, and at a season of the year when it was important that they should have made every day count. The pinch in this direction was being experienced by many families. Bakers and grocers were prepared to lend some assistance to the workmen in the shape of credit, but it was not to be expected that this could be continued for any great period, and the time had come when credit had to be refused, as many as forty families being cut off by bakers alone.

A calm survey of the situation, now that the trouble is over, confirms me in my opinion that the difficulty between employers and employees might have been brought to a conclusion within a short time of the first outbreak had it not been for the interference of professional agitators of the stamp of the leader Fateaux and others. Any little discontent that may be in the air to-day is caused by a fanning of the flame by these fire-eating professionals, who are the curse of the working class anywhere; and it will be a grand thing for the workmen when they recognize this fact.

## TRADE ASPECT OF THE STRIKE.

Three-weeks' lost time during the period of the strike and a reduced staff for the remainder of the season tells of a short cut. This has been placed by one leading mill owner at 25,000,000 feet. "Mill men," he

said, "would not, however, suffer any very great loss in the end, as the short cut would certainly have a tendency to stiffen prices later on. It would without doubt reduce the stock to be carried over the coming winter. The logs are coming down rapidly, and extra precaution will be taken to strengthen the booms if they have to be held over."

Shipping has been brisk throughout the month, sufficient men being secured in most cases for the work, even when the strike was in progress.

As compared with September last year the returns of the United States consulate show that last month's exports were greatly decreased. The figures are: Exports, September, 1890, \$907,321; exports, September, 1891, \$662,197; decrease, \$243,124. This is largely due to the decreased export of lumber, etc., due to the strike.

The Hon. E. H. Bronson, M.P.P., and Messrs. F. P. Bronson, W. G. Bronson, Levi Crannell and Daniel A. Martin, of Ottawa, will apply to the Quebec legislature to be incorporated under the name of the Schyan River Improvement Co. The object of the proposed company is the construction of slides, dams, piers and booms for the floating of timber.

Men in large numbers are leaving here for the shanties.

OTTAWA, CAN., Oct. 26, 1891.

## BRITISH COLUMBIA LETTER.

The Westminster Exhibition—Showing of Lumber Products—Export Shipments—A Rival to E. B. Eddy—News Gleanings.

[Regular correspondence CANADA LUMBERMAN.]

THE Annual Exhibition and Citizens' celebration held in this city 23rd to 27th Sept., was the greatest event of its kind ever held in this province. The gate receipts at the grounds were \$5,850. The exhibits surpassed the shows of former years in every respect, even in your line, lumber and wood-work exhibits. The Brunette Sawmill Co. got first prize for cedar shingles. A pair of oak doors most beautifully carved attracted great attention. Mr. Wyther, owner of the steam yacht *St. George*, of Royal Yacht Squadron, England, purchased a piece of fir plank 52 inches wide, 10 feet long by 2 inches thick, free from blemish or defect. He takes it to England and intends having a table top made of it and polished. The B. C. M. T. & T. Co. also had a very fine exhibit. So closely were these two matched that the judges have not yet been able to decide as to which to award a special prize "to the best exhibit of provincial manufacture." They showed very fine windows and blinds and took first prize for doors and windows. They showed a fir plank 50 inches wide, 26 feet long by 2½ inches thick, very smoothly sawed. The Mechanics Mill Co. amongst other fine exhibits had a very nice bar-room counter and newel post. They got second prize for doors and windows. Messrs. Welsh & Son, of this city, showed 25 pieces of native woods polished and varnished to the highest state of perfection.

## TO COMPETE WITH THE HULL PAUL KING.

Vancouver has credit for erecting the first wooden-pail factory coming directly into competition with the celebrated makers of pails, the E. B. Eddy Company of Hull, Que. I think I am correct in saying that until this time this well known concern has practically had a monopoly of this line of manufacture. The Vancouver Manufacturing and Trading Company will make a bold attempt to divide the trade with the Eddy people. We think that no better wood can be found for this use than the splendid cedars of British Columbia. The pail factory is well equipped with modern machinery and is under capable management.

## BITS OF LUMBER.

Mr. Slaughter has joined Mr. MacLaren in the Bunard Inlet mill and may not build at Stevenston.

*Rothsay Bay* has arrived from Glasgow with water works pipes and supplies.

British Columbia has determined to be represented at the World's Fair in Chicago. She proposes to exhibit a building composed of every variety of wood that grows in her forests, and to adorn it with ferns and mosses grown within her own boundaries.

H. G. R.

NEW WESTMINSTER, B. C., Oct. 24, 1891.

**PIECE STUFF FROM VARIOUS PARTS.**

BITS OF NEWS OF INTEREST TO LUMBERMEN.

The Moodyville saw mill has closed down for repairs.

It is estimated that there is in pile in Arkansas 85,000,000 feet of lumber.

Henry W. Sage & Co., are closing out their lumber business at Albany, N. Y.

About 500,000,000 feet of logs are annually cut in Maine. about one-third floating down the Penobscot and 150,000,000 down the Kennebec.

It is estimated that New Brunswick lumbermen will cut 75,000,000 feet of logs the coming winter, as compared with 130,000,000 feet a year ago.

Fire broke out in Booth's lumber yard, Rochesterville, Ont., on 27th ult. The fire was soon got under control. Damage about \$3,000; covered by insurance.

A new building is being erected in connection with the factory department of the Brunette Sawmills to meet the requirements of an ever increasing output.

East Texas lumbermen are rejoicing in heavy rains which have raised the streams and made the prospects for getting down a good supply of logs very bright.

It is said that violins made from cedar logs, supposed to have been buried 2,000 years, and now being exhumed in Cape May county, N. J., have a soft and melodious tone.

The recent sales of American walnut in London, Eng. have not indicated a very strong market and will no doubt have the effect of checking shipments, particularly of low grade logs.

Detroit has a dry-dock just finished capable of holding any craft on the lake. The plant cost upwards of \$200,000 and was necessitated by the rapid growth of the freshwater marine.

John Charlton M.P., of Lynedoch, Ont and who has a large interest in lumber, when in Saginaw, Mich., a few days ago is reported as saying that he is "confident that the log duty will not be reimposed."

The planing mills and the wood-working factory of James Dempster & Co., Halifax, N. S., were completely destroyed by fire on 27th ult. Forty men are thrown out of employment. Loss, \$20,000; insured for \$5,000.

Gillis Bros. saw mill, Paris, Ont., was completely destroyed by fire on morning 27th ult. The fire originated in the boiler house, and fanned by a stiff north wind, it quickly demolished the mill and a large quantity of timber. Loss about \$8,000; insurance \$900.

The Valleyfield Lumber Co. has been organized with a capital stock of \$40,000, to manufacture and deal in lumber, by Edmond Chausse, Joseph Marchand, Napoleon A. Hurlteau and Alcime Harteau, of Montreal, and Maderic Lamothe, of Salaberry de Valleyfield.

A sensational disclosure has been made regarding the affairs of M. R. Hansen, a well known lumberman of Hansen, Wood County, Wis., after whom the town was named. He has disappeared and is accused of forgeries aggregating perhaps \$40,000, using the name of George Hiles, a wealthy Milwau-

kee land owner, with whom he had had extensive transactions. Up to the time of the recent discoveries Hansen had been regarded an honorable business man.

The Guelph Lumber Company's limits have again changed hands, being twice inside of six months. The previous sale was for \$250,000, exclusive of mills, houses, offices and town property. A second sale has now been made, to a Michigan man, for \$335,000, exclusive of mills, houses, offices and town property, and this after some 10 years' cutting, at an average of about 10,000,000 feet a year.

**CHIPS AND BARK.**

Which is the most dandyish tree? The spruce tree.

More than 300,000 persons are occupied in the United States in the direct manufacture of forest and saw products alone.

Rosewood takes its name not so much from its color as its fragrance when first cut. It still remains prince among the finer woods, being worth \$750 per 1,000 feet board measure.

An old toper, while ruminating on the cause of his numerous tumbles, came to the satisfactory conclusion that it was quite in accordance with natural laws. He says: "Leaves have their time to fall, and so have I; the reason is the same; it comes of our getting dry; but the difference between leaves and me is that I get dry more frequently."

There is a man who own the site of a sawmill in New York. He did own the sawmill and a wasps' nest. He set fire to it and incidently, everything but the sawmill site was removed with the nest. The cure was rather expensive but this incident teaches that people cannot be too careful. The majority of damages to machinery losses of mills and accidents of all kinds are caused by acts just as foolish as the burning of a sawmill to get rid of a nest of wasps.

**HIRING AN ENGINEER.**

In hiring an engineer, obtain the best you can get for the amount of money you can pay. Do not hire a man because he is a carpenter, a machinist and a blacksmith. If he understands these trades so much the better. He may keep that power in reserve to be used in case of emergency. Hiring an engineer and expecting him to do the work of three or four men, besides attending to his boilers and engine, is not a good practice. It is certain that while a man is putting on belts, oiling the machinery or screwing down cap bolts, he cannot be attending to the steam power of your establishment. The first that is known there will be a crank pin melted fast to its brasses, or a cylinder head knocked out, and the repair bill would include the cost of three engineers.

**SECOND-HAND LUMBER.**

THE second-hand clothes man is a known quantity in all the large communities, and the dealer in second-hand furniture, stoves, books, and other articles of general merchandise is a familiar citizen of the modern city. But it has been given to New York to develop the dealer in second-hand lumber. He has hung on to his shingle, and makes an honest living, for lumbermen make their living in no other way, in buying and selling the lumber that is released by the extensive repairs and alterations that are always going on in that great city. A year ago a truckman for one of these firms was struck on the head by a beam which fell from the second story of a house which was undergoing repairs. His skull was fractured and at the hospital thirty-five pieces of the same were removed. He brought suit for damages against the owner of the house and last week the jury gave him a verdict for \$7,500.

**LITERARY MENTION.**

One of the thoroughly readable weeklies of this city is *Saturday Night*, and the success that has attended its publication is a practical compliment to its merits. Every one reads the *Saturday's* comments on current topics signed "Don," which is the well known pseudonyme of E. E. Sheppard, the editor. This writer touches every subject on which he writes with a practised pen and in a manner alike refreshing and bright. Society news, music and the drama are leading departments, and each edited with care and knowledge of the subject handled.

The Magnolia Anti-Friction Metal Co., of New York, having offices at Chicago, London, Berlin, Marseilles, St. Petersburg and Vienna, made greater sales and did more business in the month of September this year than they did the first 18 months of the company's existence, commencing several years ago.

Messrs. Carthew-Findlayson, Dalby, Claxton & Banks, of Victoria, B.C. have formed a Company. The Royal Canadian Packing Co. The principal place of business will be Claxton on the Skeena River—capital, \$100,000. Besides the canning business they will go into saw milling and manufacture of all kinds of fish oils.

**FOR SALE—A RARE CHANCE.**

A VERY desirable mill property in the town of Essex, Ont., known as the Hanlan Mills, for the manufacture of staves and lumber. The daily capacity of 20,000 feet of lumber and 34,000 staves. Twelve acres of land for mill yard, on which is located 4 charcoal kilns, 1 boarding house, two tenant houses, barns sheds and other outbuildings, with an unlimited supply of pure well water; with or without horses, trucks, waggons, etc. Also six million feet of standing timber, one-half elm; balance oak, cottonwood, ash, maple and sycamore; from one to three miles from the mill; and other timber in easy reach can be bought. The mills are on the line of Michigan Central Railway, with two spurs running into the mill yard, and within fifteen miles from Detroit. Terms liberal. Good reasons given for selling. Write or call on the proprietor, T. H. DECEW, Essex, Ont.

**WANTED AND FOR SALE.**

Advertisements will be inserted in this department at the rate of 15 cents per line each insertion. When four or more consecutive insertions are ordered a discount of 25 per cent. will be allowed. This notice shows the width of the line, and is set in Nonpareil type. Advertisements must be received not later than the 27th of each month to insure insertion in the following issue.

WANTED a cargo of one inch Basswood lumber. Address, F. ZIMMERMAN, Cleveland, Ohio.

A 25,000,000 Timber Limit for Sale. Easy to water; close to rail; good mill site; will be sold far below value. Address, LUMBERMAN Office, Box 421.

**Saw and Shingle Mill for Sale.**

FIRST-CLASS water power, with 40 feet head. Any quantity of good timber at hand. Sold cheap if not soon. Address, ALEX. MITCHELL, Jr., Red Wing, Ont.

**WANTED FOR CASH.****Half a Million Feet of Ash.**

MOSTLY 1 inch, some 1½ and 1¾ inch Canada Ash, strictly first and seconds; must be of uniform color, also commons and 1 inch Elm, I and II State particulars as to stock on hand dryness and lowest prices F. O. B. Montreal, Que. Address all particulars to

P. O. Box 2144,

NEW YORK,

N. Y.

PARTNERSHIP WANTED in Sawmill, Sash and Door or Furniture Factory, or any other class of good wood-working establishment. Advertiser will invest \$5,000 cash. Address, "PARTNER" care of CANADA LUMBERMAN.

**WANTED—TO BUY.**

GOOD Canadian Timber Limits and Georgian Bay saw logs. Address, BEN BIRDSALL, Whitney Building, Detroit, Mich.

HARDWOOD lumber, bought, sold or received on consignment, TUCKER DAVID, lumber commission merchant, 202 Eleventh Ave., N.Y.

**SAW AND SHINGLE MILL**

FOR SALE—on the Manitoulin, near Little Current. A bargain. Address, W. L. H., CANADA LUMBERMAN.

**SHINGLE LIMIT WANTED.**

WANTED—Good shingle timber limit. Address, P. J. D., care CANADA LUMBERMAN.

**PARTNER WANTED.**

WANTED—Partner—Silent or active, with \$10,000 to \$15,000, to handle lumber 1892. Address, T. C. F., care CANADA LUMBERMAN.

**STEEL RAILS, ETC.**

SEVERAL thousand feet T rails 12 and 20 lbs. to the yard. A large quantity of flat strap rail for tramways. 20 pair wheels and axles, all in good second hand condition, very cheap.

JOHN J. GARTSHORE,

49 Front Street, West,

Toronto.

**FOR SALE, RENT OR PARTNERSHIP**

FIRST CLASS saw mill, planing mill, sash and door factory and dry kiln, 35 pieces of machinery in complete running order, situated just outside of limits of city of Kingston. Premises suitable for a ship yard, or will sell machinery, dry kiln or building for removal. For particulars and catalogue of machinery address M. STRACHAN & SON, Kingston, Ont.

**GOOD BUSINESS CHANCE**

A party having the disposal of about 50,000,000 feet of good standing White Pine under Government license, besides a vast quantity of standing Hemlock, Spruce, Birch, &c., in a most convenient part of the District of Muskoka, together with a good Mill, nearly new, containing the very best machinery, is anxious to meet with a purchaser or parties willing to form a joint stock company. The whole property will be put in at an extra good bargain, and employment arranged for practical men. Full particulars as to Limits, Mill and prices, map, &c., can be seen at the office of the "Canada Lumberman."

**PLANING MILL FOR SALE.**

A Planing Mill and Sash and Door Factory in running order and fully stocked with best machines. Land freehold. GOOD LOCATION IN TORONTO. WILL BE SOLD AT A BARGAIN ON EASY TERMS.

Apply to "Planing Mill"

Canada Lumberman.

**WANTED SAW MILLS****IN - LITTLE - BELT**

—AND—

**ROCKY MOUNTAINS**

ALONG LINE OF

**Great Northern Railway**

For particulars write

**J. M. HUCKINS,**

4 Palmer House Block, Toronto

Or F. J. WHITNEY, Gen. Pass. Agent, St. Paul, Minn.

**WILLIAM FOSTER****Lumber & Commission Merchant**

Receiver and forwarder of

**LUMBER, LATH & SHINGLES**

Correspondence Solicited.

OWEN SOUND,

ONT.



*Repairing*  
*Promptly and*  
*Carefully*  
*Executed*

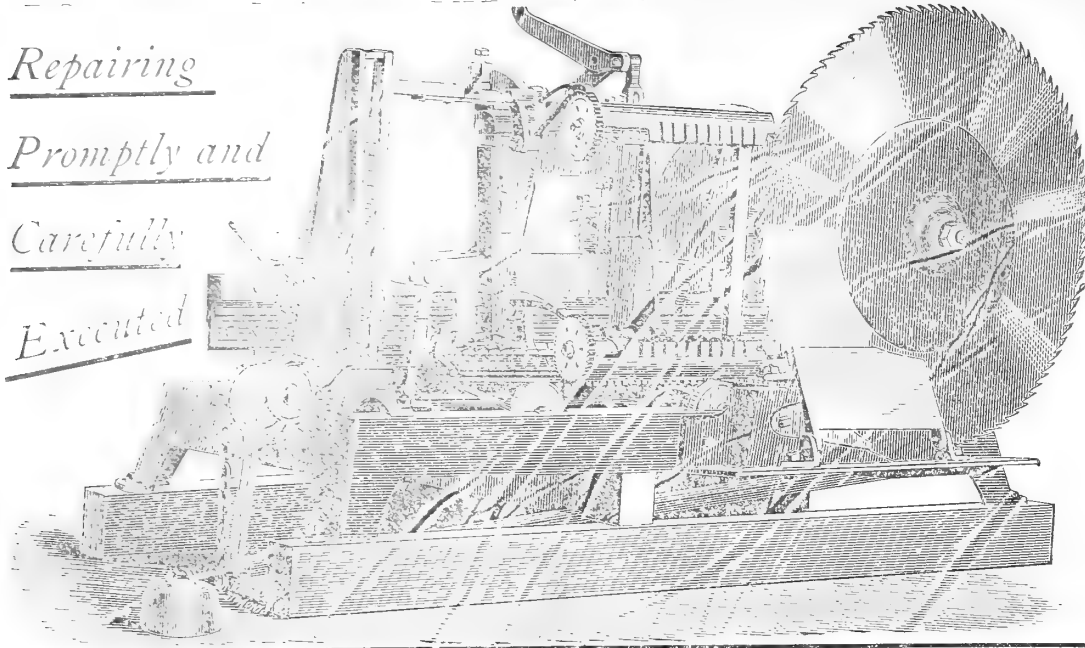

# B. R. MOWRY & SON

MANUFACTURERS OF

**Saw Mill  
and Shingle Mill  
Machinery.**

*Shingle Machinery a Specialty.*

## The "BOSS" SHINGLE MACHINE

Manufactured by us is acknowledged by practical men to be the best machine in the market.

GRAVENHURST, ONT.

# The \*XXX\* Saw \*Gummer \*and \*Sharpener

### HAS NO RIVAL

### For Variety, Capacity or Quality of Work.

OR FOR

### Simplicity, Durability, Cheapness.

Will take saws from 6 inches to 6 feet diameter, sets the saw forward one tooth at a time automatically. Sharpens any saw (rip or cross-cut) perfectly. Giving the teeth any desired pitch or bevel, and making all the teeth exactly alike. Will sharpen 20 teeth in ordinary mill saw in One Minute, or 100 teeth in shingle saw in four or five minutes. The cut shows outline of mill saw 54 inch dia. Patent applied for.

GILMOUR & Co.  
Lumber Manufacturers and Dealers.

Trenton, Ont., 26th Aug., 1891.

F. J. DRAKE Esq, Belleville, Ont.

Dear Sir,—Your Patent Saw Sharpener is giving us good satisfaction. We average about one hundred thousand shingles per day, and sharpen the saws for both automatic and hand-feed machines with your Sharpener. As it keeps the teeth all perfectly uniform it must be easier on the machine and sawyer too. It causes also a great saving in files. We now only use about one 10 in. file per week. Before putting in your machine we used about six per week. As regards your Improved "XXX" Shingle Packer—they work first rate, and are the only machines we could get that would press tight enough. We consider them the best we ever had.

Yours truly,

GILMOUR & CO.

MANUFACTURED ONLY BY

## F. J. DRAKE

Belleville, Ontario.

# The Sturtevant System of Heating AND Ventilating

Applicable to all classes of Buildings.

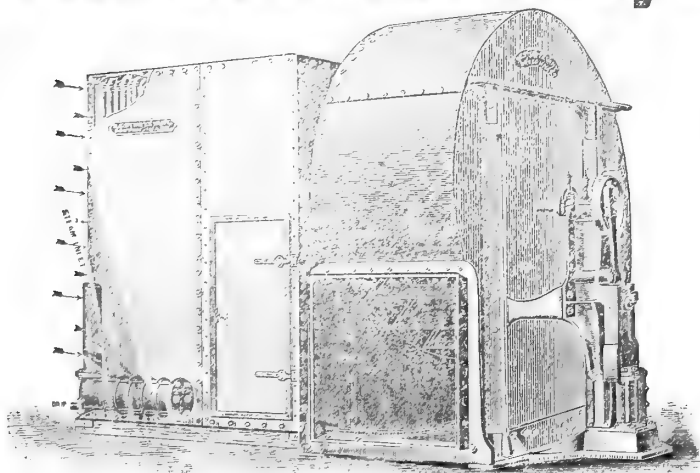

## PROGRESSIVE LUMBER DRY-KILNS.

## Steel Plate PLANING MILL Exhausters

SEND FOR CATALOGUE.

## B. F. STURTEVANT CO., BOSTON, MASS., U. S.

BRANCHES:

91 Liberty St. New York; 16 S. Canal St., Chicago 135 N. Third St., Philadelphia.

A. R. WILLIAMS, Soho Machine Works, Toronto, General Agent for the Dominion

The Sturtevant System of Heating and Ventilating Apparatus.

# H. W. PETRIE, Machinist and General Machine Dealer

ESTABLISHED 1876.

Main Office, Yard, Storehouse and Shipping Depot, Opp. Union Passenger Station, Toronto, Canada

\* 141-145 FRONT ST., WEST. \*

Send for  
One of My  
New  
Catalogues  
FREE.

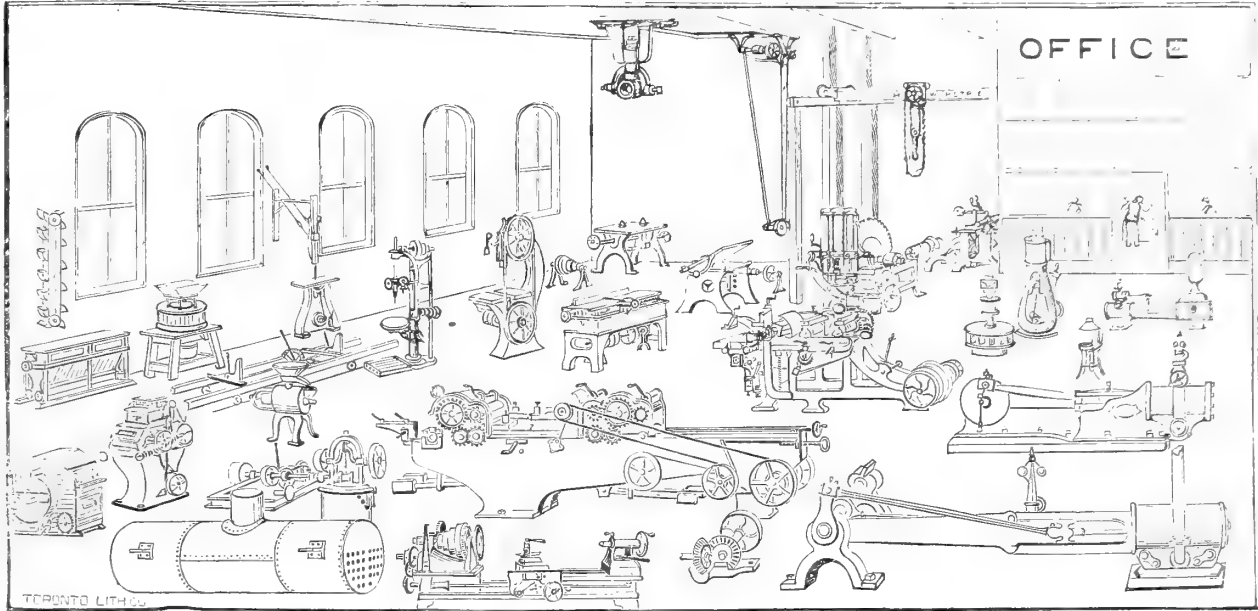

New  
66 Page  
Descriptive  
Catalogue  
Just Out.

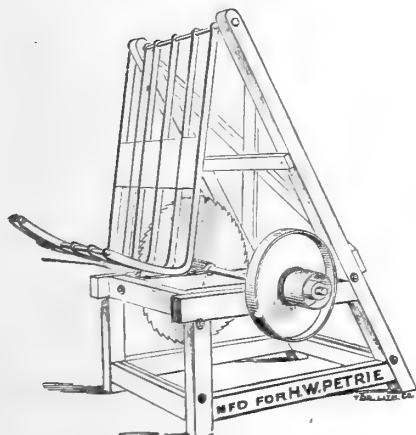

Wood and Shingle Bolt Saw.

## WOOD YARD MACHINERY

:- A Specialty. :-

See New Catalogue No. 16.

The Improved Little Giant Planer, Matcher and Moulder.

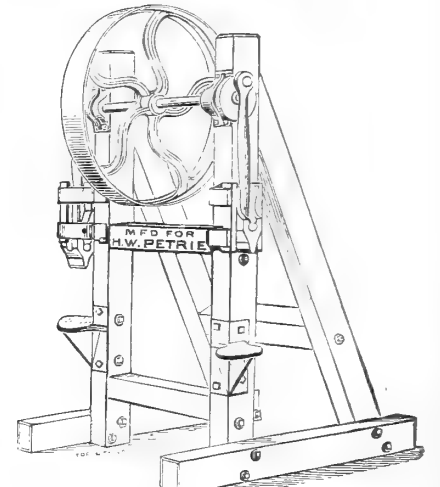

'The Champion Wood Splitter.

**25,000**  
**CATALOGUES**

NOW READY

FOR DISTRIBUTION

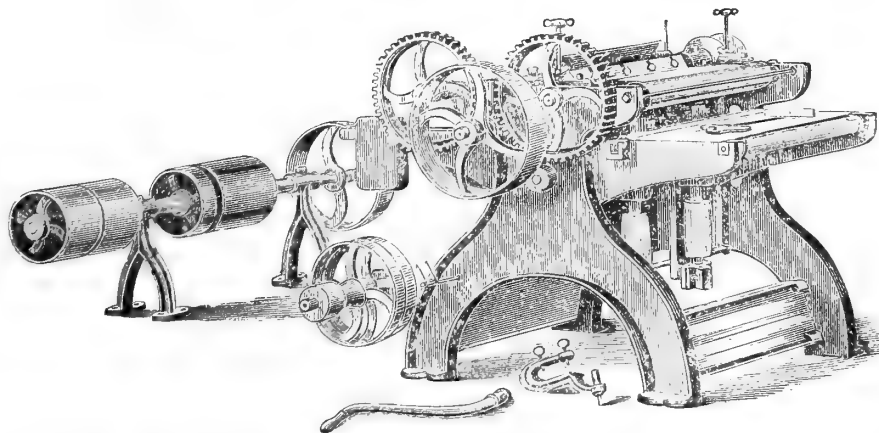

CATALOGUE NO. 16

GIVES FULL

**DESCRIPTION**

OF ALL

OUR MACHINERY



**Planing and Saw Mill Machinery of all Kinds.**



**CIRCULAR**



**\* \* SAWS. \* \***

Cant Dogs, Peavies,  
Skidding Tongs,  
Pike Poles, Coldshuts,  
Lumber Bob Sleighs. \*

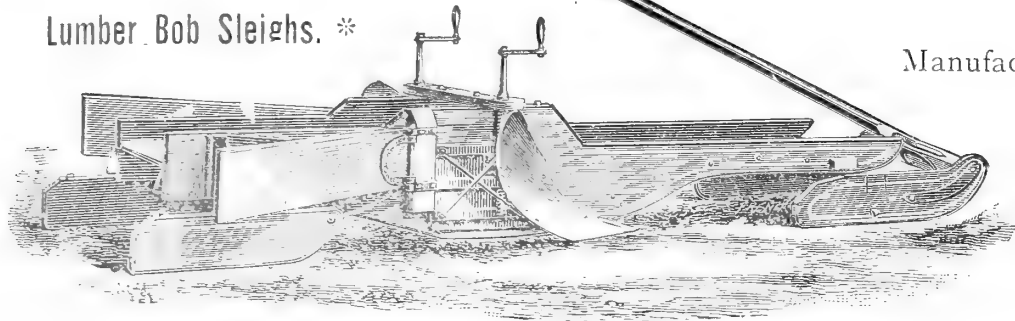

# J. Muckleston & Co.

Kingston, Ont.

Manufacturers of RED TOP LINE  
**LUMBERMEN'S \* TOOLS**

And Sole Licences for the Manufacture in the Dominion of  
**BRAZEL'S PAT. SNOW AND SIDEWALK  
PLOWS.**

**DODGE PATENT**

## Wood \* Split \* Pulleys.

*We guarantee 30 to 60 per cent. more  
Power with same belt.*

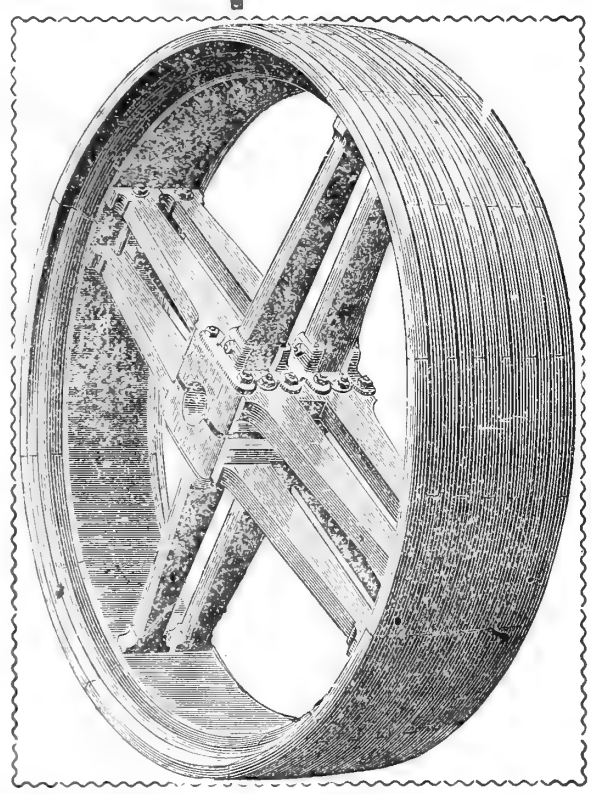

*Every Pulley guaranteed strong enough  
for Heaviest Mill Work.*

All Sizes in Stock. Send for Catalogue.

**DODGE WOOD SPLIT PULLEY CO.**  
83 King St. West, Toronto.

WHEN YOU ARE IN NEED OF **PRINTING**

You will consult your own interests by sending your order to

**THE CANADA LUMBERMAN JOB DEPT. \***

If you are in need of Stationery for your office, shanties or drives, let us know your wishes and we can guarantee that both our work and prices will please you. Address, The Canada Lumberman Job Dept., Canada Life Building, Toronto, Ont.

## DONOGH & OLIVER,

Wholesale Dealers in

# LUMBER

OFFICE:

Nos. 213, 214 and 215, Board of Trade Building,  
COR. YONGE AND FRONT STS.

**TORONTO, ONT.**

\*\*\*\*\*  
**Advertising** IN The Canada Lumberman **PAYS**

**Write for Rates.**

\*\*\*\*\*

# OUR FRICTION GRIP PULLEYS

**ARE THE ONLY SPLIT GRIP PULLEYS & CUT OFF  
COUPLINGS MADE. GIVE EVERY SATISFACTION AS  
DRIVERS OR DRIVEN PULLEYS. FULLY GUARANTEED.**

**WATEROUS ENGINE WORKS CO.**  
BRANTFORD, CANADA

<b>ELECTRIC LIGHT PLANTS</b>	<b>THE THOMSON-HOUSTON AND THOMSON SYSTEMS.</b>	<b>FOR MILLS AND FACTORIES.</b>
<b>THE ROYAL ELECTRIC CO. ADDRESS 58 WELLINGTON ST. MONTREAL, QUE.</b>		



**A. M. DODGE & CO.**  
**M**ANUFACTURERS of and Wholesale dealers in all kinds of Lumber, Lath and Shingles. Tonawanda, N. Y.

**COWPER & CREGORY.**  
**R**ECEIVERS and Forwarders of Lumber, Lath, Shingles, &c. Unexcelled facilities for shipping by canal or rail. Tonawanda, N. Y.

**CHEESMAN DODGE**  
**T**IMBER and Lumber Merchants. Ship and Boat stock, Railroad Ties, &c. Office, 16 West Seneca Street, Buffalo.

**EMMET FLEMING**  
**I**NSPECTOR and Commission dealer in Lumber. Office, 251 Louisiana Street, Buffalo, N. Y.

**LAYCOCK LUMBER CO.**  
**M**ANUFACTURERS of Pine, Hemlock and Oak Timber up to 8 1/2 feet in length. Saw Mills: Ackley, Pa., Black Rock, N. Y., Gravenhurst, Ont. Office, corner Main and Seneca Sts. Buffalo, N. Y.

**J. & T. CHARLTON**  
**W**HOLESALE dealers in Masts and Spars, Canada Round Pine, &c. Tonawanda, N. Y.

**WILLARD W. BROWN.**  
**202** Main Street, Buffalo, handles all kinds of Hard Woods.

**A. P. & W. E. KELLEY CO.**  
**W**HOLESALE Lumber dealers. Yards at Tonawanda and Chicago. Correspondence invited.

**C. P. HAZARD.**  
**W**HOLESALE dealer in Lumber, Shingles, Lath and Fence Posts. Correspondence invited from the Canadian trade. No 92 River Street, Buffalo, N. Y.

**L. A. KELSEY LUMBER CO., (Ltd.)**  
**M**ANUFACTURERS and dealers in Hardwood Lumber of all kinds. Describe stock and write for prices. Office Tonawanda, N. Y.

**BOVEE & HOWDEN**  
**M**ANUFACTURERS and Wholesale dealers in Hard and Soft Wood Lumber. Holders of Canadian stocks are invited to write for quotations. Offices at Tonawanda and Le Roy, N. Y.

**THE TONAWANDA LUMBER CO.**  
**M**ILLS at East Tawas, Mich.: office, 106 Main Street, opposite N. Y. C. and H. R. R. R. Station, North Tonawanda, N. Y.

USE SPOONERS BOX-METAL COPPERINE FOR SAW MILLS AND CIRCULAR SAWS. PLANNING MILLS AND HEAVY WORK. FINE SOLID OLD MACHINERY. HARDWARE STORES. ALL SELL THIS WORLD IN PERFECTION. PATENTED.

**LUMBER TRUCK \* WHEELS.**

**The Montreal \***

**\* Car Wheel Co.**

MANUFACTURERS OF

**CHARCOAL IRON CHILLED RAIRO AD WHEELS**

Offices: New York Life Insurance Building, Montreal.

Works: Lachine, Quebec.

**W**E make a Specialty of Wheels suitable for the requirements of Lumbermen and Street Car Service, and can supply them Bored, Finished and Balanced.

CORRESPONDENCE SOLICITED

**J. J. TURNER,**  
**Sail, Tent and Awning Maker.**  
 251 GEORGE AND 154 KING STREETS, PETERBOROUGH.  
 Canoe, Yacht and Boat Sails made to order. Perfect Fits guaranteed.  
 Every description of Lumbermen's Supplies and Waterproof Clothing.

**THE MONARCH BOILER AND HERCULES ENGINE.**

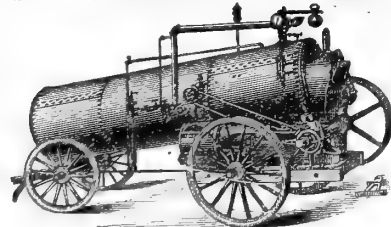

Portable from 6 to 70 horse power. Surpass portable steam power heretofore produced for strength, durability, compactness, and the ease with which they can be moved. The 70 horse power can be taken over the roughest roads, or into the forest, and set up as easily and quickly as an ordinary 20 horse power portable engine, and as firm as a brick-set stationary engine. Engines and boilers of every size and description. Rotary Saw Mills, Shingle and Lath machines, Log Grinders, Planers, etc. Mill machinery and supplies of every description. Every boiler insured against explosion by the Boiler Insurance & Inspection Co. of Canada. Write for circulars.

**A. ROBB & SONS,** Amherst Foundry and Amherst, N.S. Machine works.  
 ESTABLISHED OVER 40 YEARS.

HERBERT G. ROSS. Box 273. REGINALD C. BLAKER.

**H. G. ROSS & CO.**

*Real Estate, Fire and Life Insurance, Shipping and General Commission Agents.*

Timber Limits and Farming Lands a Specialty.

A.B.C. Code, Cable address, "Ross."

**NEW WESTMINSTER. - - - B. C.**

CORRESPONDENCE SOLICITED.

**PORTER, ROBERTSON & CO.**

STOCKS STRIPS SIDINGS BILLSTUFF

WHOLESALE

**LUMBER**

DEALERS

HARDWOODS HEMLOCK SHINGLES LATH, ETC

*Millichamp's Buildings,*

**35 \* Adelaide \* Street \* East, TORONTO.**

YARD: NORTHERN DOCK, FOOT OF BATHURST STREET.

GEO. HASTINGS.

JOHN CRAY.

H. HANCOCK.

**GEO. HASTINGS & CO.**

**Lumber Merchants**

TRUST BUILDING CHAMBERS,

Cor. Yonge and Colborne Streets.

**TORONTO.**

**All Kinds of Pine and Hardwood Lumber.**

BILL STUFF CUT TO ORDER A SPECIALTY.

**NAPANEE CEMENT WORKS**

— MANUFACTURERS OF —

**Hydraulic Cement**

PARTICULARLY adapted for Dams, Smoke Stacks, Foundations, Culverts, Cisterns, Cellars, etc.

ENDORSED BY LEADING RAILWAYS AND CONTRACTORS.

**ROACH \* LIME,**

For Building, Plastering, Gas Purifying, Paper Making, &c.

**THE RATHBUN COMPANY, DESERONTO, ONT.,**

MANUFACTURERS OF

**\* TERRA \* COTTA \* FIRE-PROOFING \***

For Use in Old and New Buildings.

Endorsed by Leading Architects. Absolutely Fire-proof. About as Cheap as Wood or Brick. Weight One-Third that of Brick. Does not Crack on application of Heat or Water.

Deadens Noise. Gives Warmth in Winter; Coolness in Summer.

**Galt \* Machine \* Knife \* Works.**

**MACHINE KNIVES**  
 OF EVERY DESCRIPTION FOR  
**Planing, Moulding & Stave Cutting.**  
 SEND FOR PRICE LIST

*PETER HAY, - - - GALT, ONT*

80 H.P. CUT OFF COUPLING.

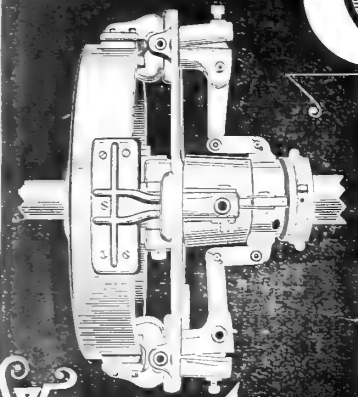

# GRIP

Pulleys & Cut off Couplings.

10 x 3 TO 10 x 30

SPLIT OR SOLID

GUARANTEED.

AFTER USING YOU WONDER HOW YOU MANAGED WITHOUT IT.

WATEROUS ENGINE WORKS Co. Brantford, Can.

A FEW REFERENCES

FOR GRIP PULLEYS AND COUPLINGS.

Martin, Mitchel & Co., Elevator.....	Winnipeg.....	3-78x 6
Cookshire Mill Co. (Saw Mill).....	Cookshire, Que.....	5-48x12
P. & A. McGibbon, Saw Mill.....	Lachute, Que.....	1-33x16
J. C. Wilson & Co., Paper Mill.....	Lachute, Que.....	2-36x12
E. Buse, Saw Mill.....	Vancouver, B. C.....	1-48x12
Waterous E. W. Co.....	Brantford.....	14-36x 8
Riordon Paper Mills.....	Merriton, Ont.....	4-36x 8
Globe Printing Co.....	Toronto.....	2-42x12
Brooke Woolen Co.....	Simcoe.....	1 Split-30x 6
Hall & Price, Saw Mill.....	Quebec.....	3-30x16
George Erb.....	Winnipeg.....	1 Split-36x12
A. A. Benson.....	Montreal.....	1 Split-36x12
W. H. Law.....	Peterboro'.....	1-24x 6
Northumberland Paper Co.....	Campbellford.....	1-36x12
Electric Light Co.....	Kat Portage.....	1-48x12
R. Lang & Son, Tanners.....	Berlin.....	1-30x 8
Wisner, Son & Co.....	Brantford.....	1-34x 9
W. Sutton, Grist Mill.....	Simcoe.....	1-32x10
E. Lavendaro.....	S. America.....	4 { 90x16, 60x13 81x10, 44x10
Miller & Bunting, Veneer Works.....	St. Catharines.....	1-48x 9
Hunt Bros., Electric Light and Mills.....	London.....	6 { 56x12 72x16
S. Frank Wilson, Publisher.....	Toronto.....	1-46x13
Kuntz Brewing Co., ice elevator.....	Hamilton.....	1-30x 8
W. B. & S. Anglin, Saw Mill.....	Kingston.....	1-36x14
C. S. Hyman & Co., Tanners.....	London.....	1-30x 8
American Watch Case Co.....	Toronto.....	1-26x 9
M. C. Keith, Saw Mill.....	Central America.....	1-22x 8
Westman & Baker, Machinists.....	Toronto.....	1-24x 6
A. Harris, Son & Co.....	Brantford.....	1 coupling
British American Starch Works.....	Brantford.....	2 couplings
North Pacific Lumber Co.....	Port Moody, B. C.....	1-48x21
Firstbrook Bros., Bx Makers.....	Toronto.....	2 { 42x 8 42x12
Bertram & Co., tool makers.....	Dundas { Duplex... { 3-15x 4 1/2 Toronto { Pulleys... { 2-10x 3	
James Morrison, brass works.....	Toronto {	2-10x 3
Canadian Copper Co.....	Sudbury.....	1-48 in. Sprocket
Clough & Co., Elevator.....	Lennoxville.....	1-18 in. Sprocket
Royal Electric Light Co.....	Montreal.....	3-9x19&22
Gurney Scale Co.....	Hamilton.....	Grip Sprocket
Grand Trunk Shops.....	Hamilton.....	Cut off coupling
British American Starch Co.....	Brantford.....	1-36x 8
W. S. Shaw, tannery.....	Bracebridge.....	4-18x 8, &c.

A FEW RECENT SHIPMENTS.

Genelle Bros., Sawmill, Tappen Siding, B.C.	1-20x10 in. face	W. H. McCordick, St. Catharines.....	1-30x 9 in. face
J. L. Pink, Grist Mill, Toronto.....	1-40x 9	Waterous Engine Works Co., St. Paul, Minn.	1-30x 9
J. Nightingale, Brick Works, Toronto.....	1-30x14	J. A. K. Drummond, (elevator work) Manitoba	2-20x 6
Dowling & Leighton, Furniture, Harrison, Ont.	1-24x 6	A. Harris, Son & Co., Brantford.....	2-18x 8
Toronto Radiator Co., Toronto.....	1-40x 7	Letang & Letang, Montreal.....	1-12 in. Sprocket
Taylor Bros., Brick Works, Toronto.....	1-30x14	Pettit Bros., sawmill & stave works, Comber	5-64x17 in. face
J. J. Coulter, Toronto.....	1-22x 9	Adamson & Co., (for elevator work) Manitoba	1-24x 7 in. face
Nanaimo Electric Light Co., Nanaino B.C.	2-30x 8	J. Morrison, (for lathes) Toronto.....	1 pair 12x 4
For Elevator Work, Manitoba.....	1 Cut-off Coupling	Ogilvie & Co., Grist Mill, Seaforth.....	2-36x10
W. Milne, Sawmill, drive bull-wheel, Stayner	1-16x10	American Mill Building Co., Stratford.....	3 { 28x 6 49x13 28x13
Windsor, Sandwich & Amherstburg Electric	2 { 48x16		
Railway, Windsor.....	2 { 60x12		
British America Starch Co., Brantford.....	1-48x14		

Many, after trial, make further purchases of our Pulley.

# WATEROUS

Is the name we ask you to remember when about to purchase **SAW MILL MACHINERY, ENGINES, BOILERS, FRICTION GRIP PULLEYS.**

Brantford, - Canada.

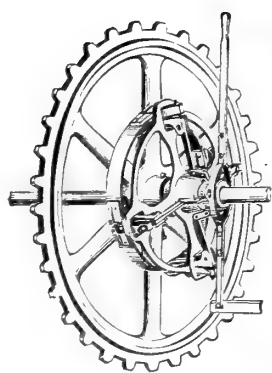

A Driven Grip Sprocket.

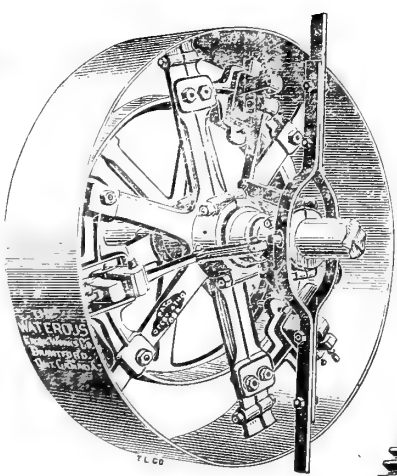

A Driving Grip Pulley.

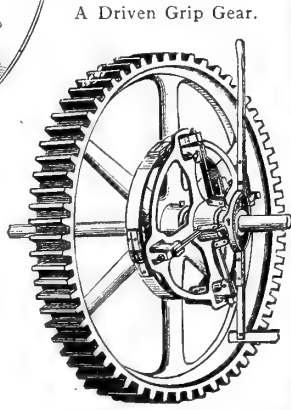

A Driven Grip Gear.

SPECIALLY NOTE

Grips always motionless when pulley out of clutch.

Not necessary to stop an important shaft with a dozen pulleys on it to adjust an unimportant pulley.

Orders from 7th to 23rd October.

North American Mill Building Co.....	Stratford.....	2 { 28x13 36x13
Practical School of Science.....	Toronto.....	1-36x16
Riordon Paper Co.....	Merriton (their 5th order)	1-24x 6
Walkerville Mal. Iron Co.....	Walkerville.....	1-40x10
E. B. Eddy Co.....	Hull.....	10-44x13
Barber Bros., Paper Mill.....	Georgetown.....	1-40x12
Globe File Works.....	Port Hope.....	1-16x 7
Tallman & Son, Brick Works.....	Beamsville.....	1-24x14
George Erb, elevator.....	Winnipeg.....	1-46x14
George Wright.....	Fort Corington, N. Y.....	2-24x 8

# Our FRICTION GRIP PULLEYS

ARE THE ONLY SPLIT GRIP PULLEYS & CUT OFF COUPLINGS MADE. GIVE EVERY SATISFACTION AS DRIVERS OR DRIVEN PULLEYS. FULLY GUARANTEED.

WATEROUS ENGINE WORKS Co.  
BRANTFORD, CANADA.

**JOHN BERTRAM & SONS,**  
 CANADA • TOOL • WORKS  
**DUNDAS, ONTARIO.**  
 MANUFACTURERS OF  
**WOOD-WORKING MACHINERY**  
 MACHINE TOOLS, ETC.  
 Write for Prices and Catalogues

C. C. CLEVELAND. G. F. CLEVELAND.  
**J. L. GOODHUE & CO.,**  
 MANUFACTURERS OF  
**Leather Belting**  
 AND  
**Lace Leather.**  
 DANVILLE - - QUEBEC.

**GEO. CORMACK**  
*Wholesale and Retail Dealer in*  
**All kinds of LUMBER.**  
*Lumber Shipped to all parts by Rail or Vessel.*  
 WHITBY, - - - ONTARIO

**Toronto**  
**Lithographing Co.**  
**LITHOGRAPHERS & ENGRAVERS.**  
 TORONTO.

THOS. WHALEY, President. W. E. HUTCHINSON, Sec.-Treas.  
**The Whaley Lumber Co.**  
 OF HUNTSVILLE, ONT. (LIMITED)  
 Manufacturers of  
**White Pine Lumber, Bill Stuff, Lath and Shingles**  
**ALSO HARDWOOD LUMBER.**  
 All orders promptly attended to. First-class facilities for shipping.  
 CORRESPONDENCE SOLICITED.

**Peter Gerlach & Co.**  
 Manufacturer of  
  
**ALLIGATOR CHISEL-BIT SAWS**  
 The Champion Stave, Heading and Shingle Machines.  
 Ice Tools and Mill Supplies.  
**CLEVELAND, - OHIO.**  
**J. D. SHIER,**  
 Manufacturer of  
**Lumber, Lath and Shingles**  
 BRACEBRIDGE, ONT.

**ALONZO W. SPOONER**  
 PORT HOPE ONT.  
 THE HANDSOMEST TOWN IN CANADA  
 AND THE ONLY PLACE IN THE WORLD WHERE  
**COPPERINE**  
 IS MADE.  
 HARDWARES ALL SELL IT.  
**MAKER.**

**Investment Bonds.**  
**THE DOMINION SAFE DEPOSIT WAREHOUSING & LOAN CO., LTD.**  
 Head Office—The Canadian Bank of Commerce Building, King St. W., Toronto.  
**CAPITAL, ONE MILLION DOLLARS.**  
**DIRECTORS.**  
 W. D. Matthews, Esq., President. Henry W. Darling, Esq., Vice-Pres.  
 John I. Davidson, Esq. S. F. McKinnon, Esq. G. B. Smith, Esq. M.P.P.  
 H. W. Nelson, Esq. J. P. Clark, Esq. J. H. Starr, Esq.  
 M. C. Cameron, Esq. Robert Kilgour, Esq. Alexander Nairn, Esq.  
 Thomas McCracken, Esq. Robert Davies, Esq. Eugene O'Keefe, Esq.  
 Aaron Ross, Esq.  
 This Company is now issuing \$100, \$200, \$300, \$400 and \$500 investments in bonds, payable in five, ten and fifteen years from date of issue, with participation in profits, affording all the advantages of compound interest accumulations on small sums of money. These bonds are the obligations of this Company and are specially protected by a sinking fund, invested in first-class real estate mortgages. They are plain definite contracts, subject to no contingencies whatever, are non-forfeitable after one annual payment, with values definitely stated thereon. For a small outlay they secure a fixed and generous return.  
 To bondholders who complete their contracts the Company guarantee compound interest at the rate of Four Per Cent. Per Annum.  
 The Company is prepared to receive applications from reliable agents at all points where it is not already represented.  
 The **Safe Deposit Vaults** of the company cannot be surpassed for absolute security. Call and examine or write for circular **WM. KERR, Manager**

**THE RATHBUN COMPANY,**  
 DESERONTO, - - ONTARIO,  
 MANUFACTURERS OF  
**Doors, Sash, Blinds, Stairs**  
 AND ALL KINDS OF WOODEN HOUSE FINISHING MATERIALS.  
**CEDAR OIL FOR PURGING BOILERS.**  
 CORRESPONDENCE SOLICITED

**The American Lumber Yard**  
**HAMBURG, GERMANY,**  
 Offers the best facilities for Yarding and Selling all kinds of  
**American Wood Goods**  
 Address :  
**ROSENBACHER & CO.,** CARL GARTNER, Agent,  
 BANKERS, Hamburg. Hamburg.

**THE STURTEVANT PATENT PROGRESSIVE LUMBER DRY-KILN.**  
 DRIES HARD AND SOFT WOOD LUMBER WITHOUT WARPING, CHECKING OR BLUING.

The Sturtevant System of  
**HEATING**  
 Mills and Factories  
 BOSTON.  
 34 OLIVER STREET.  
 NEW YORK,  
 91 LIBERTY STREET.

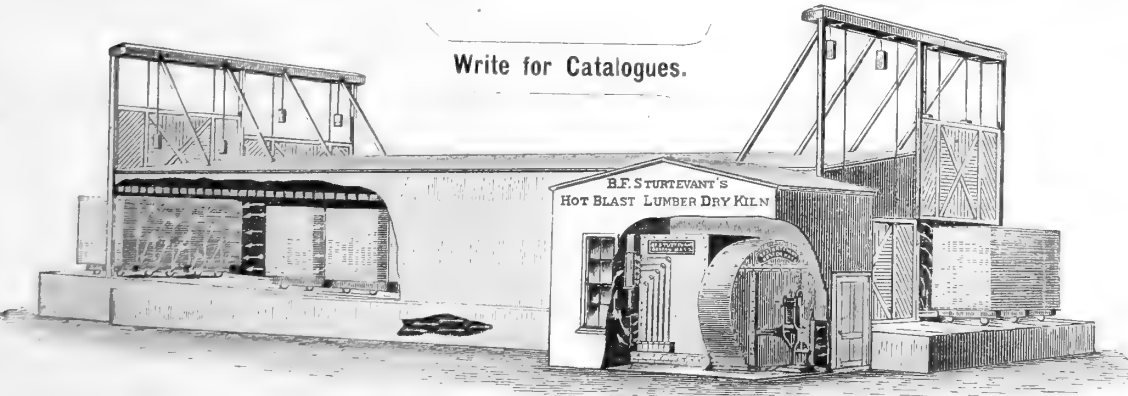

Write for Catalogues.

Steel Plate Planing Mill  
**Exhausters**  
 FOR REMOVING  
 Chips, -:- Shavings -:- and Sawdust.  
 CHICAGO.  
 16 South Canal Street.  
 PHILADELPHIA,  
 135 North Third Street.

**B. F. STURTEVANT CO., BOSTON, MAS., U.S.A.**

**A. R. WILLIAMS, Soho Machine Works, Toronto.**  
 GENERAL AGENT FOR THE DOMINION.



TAPER TOOTH.

**E. R. Burns**

LANCE TOOTH.



**Saw  
Go.  
TORONTO.**

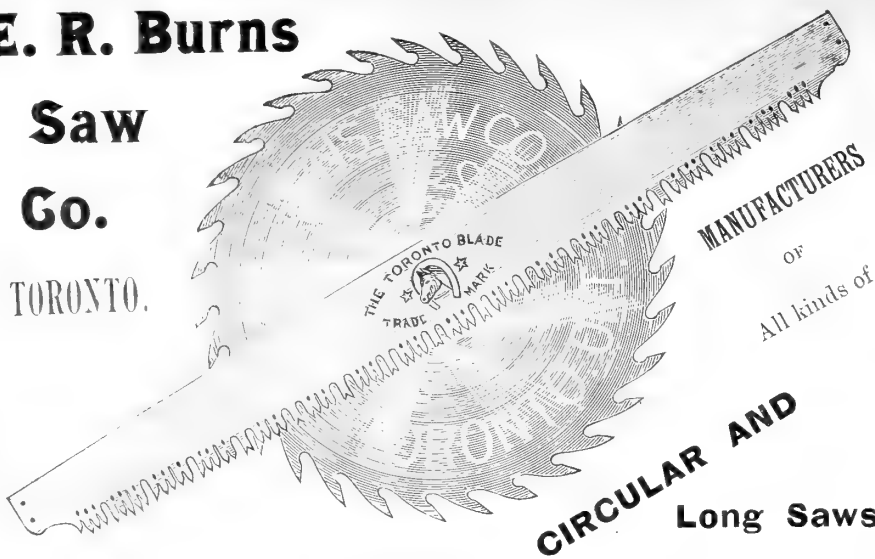

**CIRCULAR AND  
Long Saws**



**Works at Parkdale.**

TELEPHONE 5120.

**WICKES BROS., Saginaw, Mich.**

MANUFACTURERS OF

**GANGS,  
ENGINES  
AND  
BOILERS.**

The accompanying cut represents our new No. 3 Complete Iron Frame Gang Mill especially designed to meet the demand for a smaller type of mill. The strongest and most durable for high speed and thin saws. Write for further particulars.

Southern Agents.  
**M. AKDLE &  
SINCLAIR.**  
50 & 52 Barronne St  
New Orleans, La.

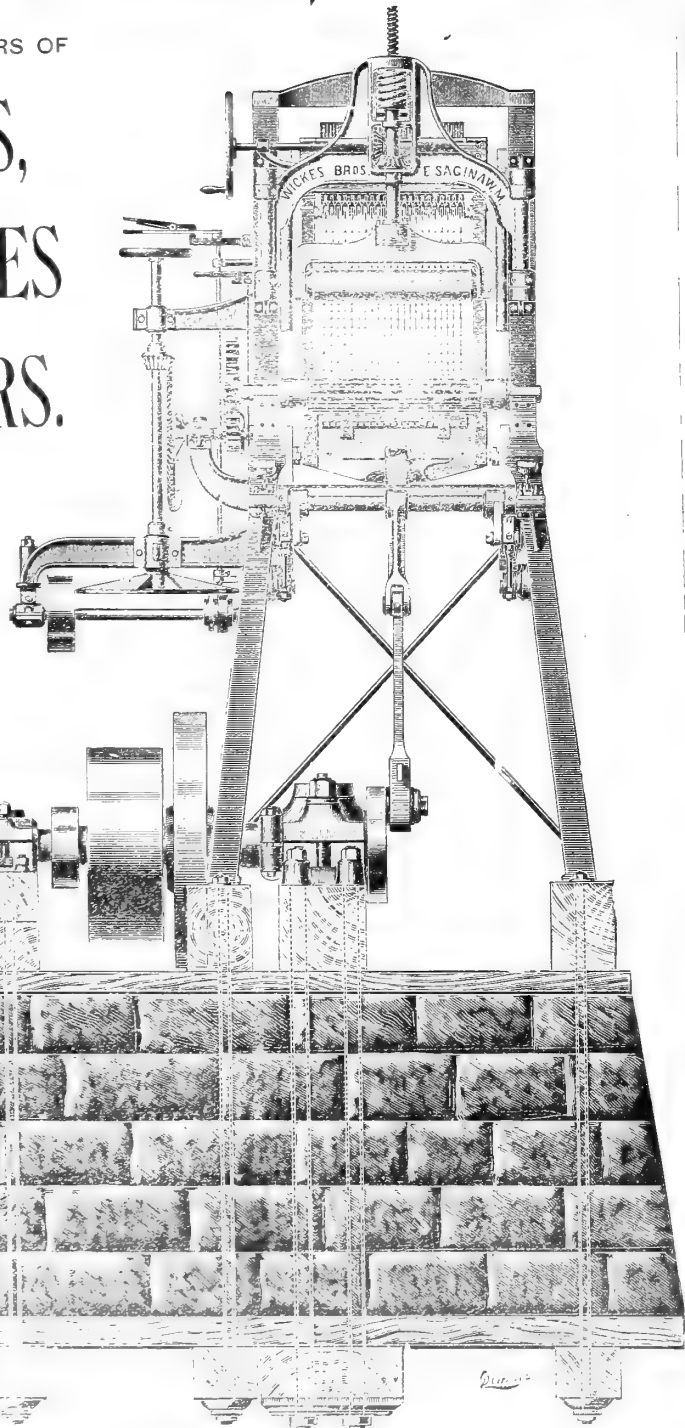

ADVERTISING

—IN—

*THE CANADA LUMBERMAN*

**PAYS.**

WRITE FOR RATES.



**SCRIBNER'S  
LUMBER  
AND  
LOG BOOK**

Over One Million Sold.

**M**OST complete book of its kind ever published. Gives measurement of all kinds of Lumber, Logs, Planks, Scantling; cubical contents of square and round Timber; hints to lumber dealers; wood measure; speed of circular saws; care of saws; cord-wood tables; felling trees; growth of trees; land measure; wages, rent, board, interest, stave and heading bolts, etc. Standard book throughout the United States and Canada. Get the new illustrated edition of 1892. Ask your book-seller for it. Send post-paid for 35 cents.

**GEO. W. FISHER,**  
Box 238, Rochester, N. Y.

or A. G. MORTIMER,  
Toronto, Ontario.

**ROCHESTER BROS.**  
Commission Agents.

Limits bought and sold on commission. Limits travelled and carefully prepared estimates given. Some first-class berths on the north shore of Lake Huron and on the Upper Ottawa now in our hands for sale. Communications confidential. References given.

36 ROCHESTER ST., OTTAWA.

TORONTO AGENCY OF

**The Rathbun Co.**

ARE OPEN TO PURCHASE

**OAK, ASH, BIRCH,  
BASSWOOD**

AND  
**GOOD PINE LUMBER**

**CEDAR AND PINE  
SHINGLES**

Manufacturers having such for sale are invited to communicate with

**T. W. WALKER, Agent  
TORONTO**

Office, Cor. Spadina Ave. & Front St.

**A. T. ANDERSON & CO.,**

CONTRACTORS FOR

**ELECTRICAL AND GENERAL MACHINERY.**

Complete installations of steam and Hydraulic Power, Electric Light and Power Plants, Wiring and Construction for Arc and Incandescent Lighting. Agents for the celebrated "C. & C." Electric Motors.

75 Adelaide Street East,  
Toronto, Ont., Canada.

Estimates furnished and every information cheerfully given to intending purchasers.  
N. B.—Only first-class work on which a full guarantee will be given.

**The Casselman Lumber Co.**

CASSELMAN, ONT. Successors to FLATT & BRADLEY.

ESPECIAL GOOD FACILITIES FOR SHIPPING.  
HEMLOCK BILL STUFF OF EXCELLENT QUALITY.

ALSO MANUFACTURERS OF

**PINE, SPRUCE, ASH, MAPLE AND OTHER HARDWOODS.**

CORRESPONDENCE SOLICITED.

J. W. MAITLAND  
H. RIXON

J. G. AINSLIE  
W. STODART

**Maitland, Rixon & Co.,**

Owen Sound, Ont.

**Saw Millers AND Lumber Dealers**

All kinds of Building Material kept in stock.

WE MAKE A SPECIALTY OF

**LONG BILL STUFF IN ROCK ELM, PINE, CEDAR AND HEMLOCK**

QUOTATIONS FURNISHED ON APPLICATION

# THE CANADA LUMBERMAN.

VOLUME XII. }  
NUMBER 12. }

TORONTO, ONT., DECEMBER, 1891.

TERMS: \$1.00 PER YEAR  
SINGLE COPIES, 10 CENTS

## MILL SURGERY.

BY JONATHAN TORREY.

SOME things have been said about surgery, or more properly dressing wounds in the mills. I had hoped to see some plan developed by which men getting hurt might receive immediate attention, and not as is often the case, be obliged to wait and suffer a long time before medical aid comes. Very many, if not the majority of cases, are wounds which common sense and good judgment will care for without the aid of a physician.

A few things should be kept in common by the men, and each one should contribute from time to time a few cents to keep a little treasury, and a little medicine chest amply supplied even for the most complicated wounds. Very often where it is necessary to call a skilled physician he often fails to bring the most needed things with him, such as lint, bandages and surgeon's plaster, and much delay is caused by hunting them up. The medicine chest should contain a pair of scissors, two or three knives, a knife made especially for spreading a plaster, needles, a good supply of bandages, alcohol, five per cent. solution of carbolic acid, arnica, and with the rest a flask of whiskey, and a roll of good surgeon's plaster. A cut, even quite a saw cut, can be drawn together with strips of surgeon's plaster, sticking it fast on one side and drawing the parts gently together until they are nicely in place, and then fasten the other side. These strips should be about three-sixteenths-inch wide, and long enough to reach over the wound and stick firmly on the skin each side of the wound. After covering the wound properly in one direction, cross them in the other, and you will find with a little care that the cut will be nicely done up. Don't be particular and cover it over tight, for it will do as well in that way. This does very well for small cuts, but for large, clean cuts made with some knife, I advise sewing up with white silk.

A bruise must be treated differently. If the skin is not broken, and no bones broken, a pail of hot water is the very best application in the world. Strip the parts immediately, and with a towel bathe the bruised parts with water as hot as it can be borne, till the intensity of the pain is gone, and often a continued bathing will free the person from all pain, and the bathing continued frequently, will be all that is needed to make a permanent cure.

For a common cut, which needs only a little immediate attention, a roll of Griswold's salve, or any good sticking plaster will be all that is necessary; and the part properly done up with this treatment will get along well enough without further trouble.

For complicated cases, however, the first thing to be done is to call the best surgical aid known. In the meantime keep the injured person as comfortable as possible. The whiskey will often be found a good assistant, for often the nervous system needs sustaining by some stimulant, and this is as good as anything for the purpose, and it is so hard to get a pure brandy of any kind, whiskey is usually the best thing to depend on.

One thing should be always borne in mind, and that is, if the person is so badly injured that he must be taken to his home, it is better to take him there before any operation is performed; not taking him to the surgeon's and then home. Ordinarily, however, it is quite as well to have the surgeon come to the mill, for here any convenience can be improvised for the operation, which can not be provided at home. It is always best to give the injured person the benefit of a doubt, and have the surgeon at hand, rather than let the wound go uncared for. Often a person is made a permanent cripple by not attending to the injured part at once.

## SOUTH AFRICAN TREES.

IN the Spring, in the year when rain has fallen for two months, the Karoo is a flower garden. As far as the eye can reach stretch blotches of white and yellow and purple fig flowers. Every foot of Karoo sand is broken up by small flowering lilies and wax flowers; in a space of a few square feet you may sometimes gather fifty kinds. In the crevices of the rocks little, hard leaved, flowering air-plants are growing. At the end of two months the bloom is over, the bulbs have died back into the ground by millions, the fig blossoms are withered, the Karoo assumes the red and brown tints which it wears all the rest of the year. Sometimes there is no Spring. At intervals of a few years great droughts occur when no rain falls.

For ten or thirteen months the sky is cloudless. The Karoo bushes drop their leaves and are dry, withered stalks: the fountains fail, and the dams are floored with dry-baked mud, which splits up into little squares: the sheep and goats die by the thousands, and the Karoo is a desert. It is to provide for these long rainless periods that all the plant life in the Karoo is modified. The Karoo bush itself provides against drought by roots of enormous length, stretching under ground to a depth of many feet. At the end of a ten months' drought, when the earth is baked brickdust for two feet from the surface, if you break the dry stalk of the Karoo bush three inches high, you will find running down the centre a tiny thread of pale green-tinted tissue, still alive with sap.

The air plants, which are fastened by the slenderest roots to the ground or rocks, live entirely upon any moisture they may draw from the air, and will grow and bloom for months in a house without any water. In other ways the intense dryness modifies vegetation.

## SAWING AND PILING.

ALMOST as much depends on the after care and handling as upon the quality of timber and manufacture. If not very carefully piled it will warp or buckle, especially thin wide stuff. The writer recently visited a band saw mill that makes a specialty of quartered oak, and saw some thin stuff—three-eighths inch panels—piled in a manner new to him. Instead of being piled on sticks out of doors, the sticks were nailed to strips at the ends and middle, forming a sort of frame, and the boards were set up endwise as nearly perpendicular as possible to prevent them falling, and under a shed were latticed sides and ends boarded up. It looked like a good deal of trouble for very little, but the millman said it paid him well for all the additional trouble and expense. He was twelve miles from a railroad, in a very rough country, but had evidently made money. He declined to state for publication the price he asked for three-eighths inch panels—only made prices to those who wished to purchase. "But," he added with it, "I sock it to him on prices, you bet." The fact that he had a well equipped band saw mill of twenty-five thousand feet capacity, plenty of fine white oak timber in sight of it, and less than three carloads of that sort of lumber on hand, was an indication that he did not lack for customers. Another idea of this man's is worth mentioning. He trimmed his lumber as it came from the saw, but did not edge it until ready to ship. This incident is given to show the care necessary in the proper manufacture of quartered oak. When so prepared and handled there is no quoted market price set on it, but it is like thoroughbred Jersey cows or imported Spanish jacks the price depends on how bad the buyer wants it. There is a good demand for it at prices that allow a profit satisfactory to any reasonable man.

## HE HAS HAD HIS DAY.

The iceman's look becomes austere,  
A frown is on his brow;  
The summer's gone, the fall is here—  
He isn't in it now.

## CAMEL'S HAIR BELTING.

ONE of the latest things in the way of a belt in this country, though it is more familiar in England, is belting made of camel's hair. The first thought of the mechanic who has had experience in buying a camels' hair shawl for his wife, and paying five or six hundred dollars for it, is that it is altogether too expensive a material for belts; but we are informed that this depends upon what particular kind of hair is selected, and that some kinds of camel's hair, that is, hair which comes from certain parts of the body, is not so expensive as to prohibit its use for this purpose. Among the advantages claimed for the belts are, they are absolutely uniform in strength and elasticity at either surface or at either edge, so that they run true and smoothly; have only one joint in them, which can be made as good and smooth as any other part of the belt; it is stronger than leather belting, and more durable; its adhesion is better, and it is adapted to use in exposed places where it is liable to become wet.

## A TIMBER STORY.

THERE are timber stories as well as fish stories. A quarter section of timber land that will cut from five to ten million feet is considered a good quarter. Fifteen million is rated extraordinary, but even that is a baby estimate when we place it by the side of a particular quarter section on the Satsop, in Mason county, recently cruised by several competent men who will testify shortly in the United States land office to the quantity they found. One of these men will testify that the quarter section will cut 40,000,000 and the whole section at least 100,000,000. It is a solid mass of fir even in the thinnest spots. When a railroad is built to this land, the quarter section alone will be worth forty to sixty thousand dollars.

## AN ESSAY ON TREES.

The following essay on trees was written by a scholar in Standard VI, of a Board School in Chelsea: Trees are very useful. There are all sorts of trees the coker-nut trees and orange, apple and plum trees. Coker nuts are very nice people. In the pacific and foreign nations live on cokernut and many other fruits. Apple trees and orange trees are very nice. Their are trees that do not bloom, oak trees and bay and corn trees and pine apple trees never bloom. Some trees are very tall they stand from the height of 10 to 15 yds. high and some are taller than that. Trees are very useful for the wild rabbits and hares and dears. There is no wild beasts in England only in foreign nations.

## PERT BUT LUCKY.

A few weeks ago a 11-year-old lad approached Marshall Field, the noted Chicago merchant, and asked him for a raise of salary.

"You'll have to go to your manager," replied Mr. Field; "he attends to the pay."

"I've been to him, and he won't do anything," said the lad.

"How much do you get?"

"Five and a half a week."

"Well, my boy, that's 50 cents more than I got when I was your age," said Mr. Field, assuringly.

"Perhaps you weren't worth any more," the lad retorted.

The youth is getting \$7 now.

### RUNNING CIRCULAR SAWS.

I HAVE seen men who, to judge by the intelligence they displayed, had better be running an axe in a wood yard. They would jamb a saw through a board like a man running a beetle and wedge. If the saw choked up and stopped, they pull the board back a foot or two, take a breath themselves, then bring the lumber slap bang against the saw again, stopping it dead. Something has got to slip; the saw belt is the thing that usually does it. The belt can't run off for it has a cob house of edgings around it. Like a horse in a horse power machine, the poor belt can kick as much as it chooses, but must run as long as it holds together.

Sometimes a well-regulated saw will bind. It will cut into the work and cut a wider strip than can pass between the saw and fence. Now the average man tries to remedy matters by pulling the work back. The back of the saw cuts itself clear, but there is a spot the width of the saw that has not been touched, so the saw runs in there again and is just where it was before. The trouble is caused by the saw getting hot. It expands and dishes over. The saw always dishes towards the coolest side. The cool side is the sharpest or may be has a trifle the most set in it.

When a saw acts as above, lift the board up square off the saw. If you have just started into a long board bear down on your end, and let it swing upon the edge of the table and raise clear of the saw. If nearly through the board, let it swing upon the back of the table, and raise your end of it. Be very careful to keep the board snug against the fence while lowering it back upon the saw. The cool air striking on the saw takes out all the dish, the saw straightens itself up and cuts itself clear as the board is replaced, and will go along all right. There always is one thing to look out for when a saw cuts this caper, and that is to see if the saw does not need setting or filing. Nine times out of ten this is the trouble.

In jointing boards upon a sliding carriage you will sometimes feel the board crawl sidewise as the saw crawls along. When this happens just take the saw off and play dentist for a few minutes. When a saw smokes (and when a man does also) it is time to quit. Saw the timber, don't burn it off. File a saw before it gets dull. Don't follow the rule one old chap had, viz.: "When edgings would slide off the saw without catching, then file the saw." Any saw that can be filed with a three-cornered file, should need but three strokes of the file for each tooth, two for the face and one for the back. It does not take long to go around a saw at this rate, and it can be done every time if the saw is filed before it gets too dull.

Sometimes when taking a saw from the arbor, a blue spot is found upon one or both sides of it. Just look that saw over, and see if there is not a spot of gum or dirt close to the blue spot. Glue is bad to get on a saw. Pitch is worse, and there is something in maple sap wood that is worse than either. A spot of gum upon a saw will cause it to heat, and the blue spots tell the story. Take a piece of sand stone or a soft Scotch "rag," wet the saw and scour off all the dirt or gum. Blue spots do not hurt the temper of the saw, but they are apt to spring the saw, and cause it to take a permanent set; and the only cure is hammering.

Hammering a saw is the sawyer's bugbear. Almost every one of them has tried to take a kink out of a saw by hammering, and many have failed in the attempt. The way they did was to lay the saw on the buzz planer and rounding spot up, then take a five-pound hammer and attempt to beat down the bent spot. Just like putting a saucer upside down and trying to hammer it flat. A man might as well attempt to straighten a dent in a tall hat by placing it on the floor and pounding on the top of it with the heel.

Take a steel straight-edge long enough to reach across the saw. Hold the saw nearly plumb upon your finger (if a small saw) and locate the bend. It is generally a little round spot. Lay the saw, rounding place down, upon the anvil. If you can not afford to own an anvil to true your saws upon, you are too poor to own a saw and had better sell out. Have a little hammer not larger than your finger. The face should be round and convex and not over an inch in diameter. The pene of the hammer should never be used, except

in severe cases. Strike one or two blows upon the bent place. Be sure that the saw lays true upon the anvil, or you may hammer until you are tired, for all the good it will do. After striking one or two blows, test the saw again with the straight-edge. If it shows any improvement, strike a few more blows, and test again. If no change is seen, strike a couple of hard blows and make another test.

The principle of the thing is, that the convex side of the saw is larger than the other side, so it puffs out; the hammer blows upon the smaller side, stretch the surface, and have a tendency to correct the error by swelling out this side, and, of course, shrinking the other. Sometimes hammering as above only makes the matter worse. In this case mark the place with chalk or by some other means and strike several blows in a line extending from center to circumference through the bent spot. Strike each side of the spot so as to stretch the whole saw to agree with the full place.

The simplest bend to remove is when an arc of the saw is sprung one side and the line of the bend follows the cord of the arc. All that is needed to cure is a number of light blows all in a row upon the hollow side as above, and right in the hollow or bend. The worst case to deal with is a twist, part of the saw bent one way, part of it another, and the rest of it both ways.

In this case, go for all the low places one side first. Get them all out and the saw will dish. It is very easy to deal with a dishing saw—just hammer the rim. Take the worst saw you ever got hold of, and if you can hammer it so as to be dishing, then the battle is yours. A few good blows at the roots of the teeth, and that saw is good for something.

Once get it through your head where to strike a saw and you can easily true up a bent one. If you have an old saw that you have always kept to look at, try your hand on that. Pick out a true place in it, and strike there with the hammer, and see what the effect will be. Strike four or five blows in a line and measure the bend they cause. Now, try to straighten the saw back again, always bearing in mind that you can not drive down a bulging place. You must coax it down. Do it as Paddy coaxed the pig to go ahead, by hitting him on the nose. "If the mountain won't go to Mahomet, then Mahomet must go to the mountain." If a certain part of the saw is too big, stretch the rest of the saw to correspond. It doesn't take much hammering. Have often seen saws hammered too much. It would spring the saw the other way every time, and it would have to be hammered elsewhere to get it back again.

Hammering wants to be done like filing, "just before it is needed." A small kink needs but three or four taps of the hammer. Let it go and another kink gets in, the saw springs out of shape, or you may have to get an expert to hammer it in shape again. Don't let a saw run a minute after it needs fixing. It is only a waste of time, power and elbow grease. It is ten times as much wear to the machinery, saw and man. If we could only make the men who tolerate dull, untrue saws believe the above, they might get rid of lots of hard work and poorly-cut stock.

One day while passing through a shop, a circular saw was heard making a noise as if it were having an awful hard time. Every time the sawyer forced a board against the saw it would slow down and stop after going eight or ten inches. The countershaft kept right on, and didn't care what the saw was doing. Upon going around the saw table where the belt could be seen, it was found to be sagging badly. It was too loose. The remark was made to the sawyer that "if he took up the saw belt the saw would work better." The sawyer said, "I'll be — if I take up any belts round this mill unless I have an order." That man can not be blamed, either. The foreman would fuss and fret around a man every time he found him doing a little repair work, and it shows the foreman does not know his business. The men get so they hate to mend anything. It is hard, in any shop, to make the men "take a stitch in time," but when the whining boss runs the shop, then every crack goes until it breaks clear off.

Patch up the little breaks as fast as they are found; things will work better. If the corner of a cement joint in a belt starts up, don't let it go until the belt breaks, but warm the belt, work in a little cement (one-third

fish, two-thirds common glue), hammer the parts together and drive in a few pegs. Five minutes will do the job, but it will take half an hour to mend the belt if it runs a week longer without fixing.

Some sawyers raise the table until the saw barely reaches through the work. They claim that the saw cuts better and easier. This is a mistake. It puts double the work on the saw. For example: Take an eight-inch saw and a pine board. When the board runs close to the collars, the saw cuts nearly square across, and the action of the saw is to cut off the grain of the wood and split off the pieces thus cut off. This agrees with the action of cutting tools in general. When the table is raised, the tendency is to split before. This, with the increase of the section upon which the saw acts, which is double, makes it much harder for the saw. The chip is smaller, but does not compensate for the extra section of cut.

Always run the saw as high as possible. If the pulley is small, or the machine is bolted down, raise up the saws until the collars almost project through the table. Keep the saw sharp and true. Use more oil than cuss words. Then your saw will cut a great deal of lumber, and do it easily.

### THE FAITH OF INVENTORS.

UNSHAKEN faith in their ideas, and a determined perseverance to overcome obstacles, are gifts with which inventors have been endowed, or, in common parlance, they have their inventions "on the brain"—mount their hobbies and ride them continually. If they were influenced by rewards, or hopes of reward ultimately, it would seem, in the eyes of the world at large, that there was a "method in their madness," and that the tangibility of wealth was the terminus of the "hobby" race. But we find a large proportion of inventors unbiased and uninfluenced by any hope of wealth, money or reward. They labor and experiment as though their life depended upon it; they labor with the hope only of ultimate success in accomplishing what they proposed to perform, and the labor is with them a labor of life and love. This labor is ever constant in their minds, ever uppermost in their thoughts, ever exerting itself in every movement and every action. They are determined to overcome every resistance. It is an example of the power of mind over matter—of intelligence over the forces of nature.

And what does the world not owe to inventors? Civilization, arts, and commerce are the fruits of the inventors' "hobbies," and the greater part of these fruits have been the product of toil, many years of labor, at a cost of life, privation and poverty; yet such was the inventors' faith that all obstacles have been overcome, and often after the results are obtained the fruit is left for others to mature and gather. Galileo declared the world "did move," and a prison was the result. Columbus, on the eve of his discovery, was nearly being thrown overboard by his discontented mariners. Harvey, the discoverer of the circulation of the blood, and Jenner, who first practiced vaccination, may be cited as examples of how great discoveries may be treated by the world before their discoveries are appreciated. Among the mechanics of a later day, Fulton, who was declared crazy; Colt, who had to mortgage his little stock of tools to obtain money to make his pistol; Goodyear, patiently toiling to obtain his results in the manufacture of rubber; Howe, bravely meeting all adversity to finish and introduce the sewing machine, may be cited as a few—very few—examples of struggling but afterwards successful inventors. The list might be extended almost *ad infinitum*. Yet when success is achieved and the true value of the invention appreciated, the tardy meed of praise is tendered to the persistent faith of the inventor who accomplished the results.

### A THREE CENT STAMP DOES IT.

On receipt of a three cent stamp we will mail free to any address a copy of our little hand book entitled "Rules and Regulations for the inspection of pine and hardwood lumber," as adopted by the Lumber section and sanctioned by the Council of the Board of Trade, of Toronto, June 16, 1890. Address, CANADA LUMBERMAN, Toronto, Ont.



**HOW TO REPAIR A SPRUNG OR BLISTERED SAW.**

**T**O MAKE it clear: A blister is a bent spot, or the same condition as a part of the plate forming the tooth bent for set. The plate is bent enough to stay in both cases, only a bent tooth does not change the tension, and a blister does change it; it buckles that part of the plate, and must be bent back again. This restores the tension somewhat, but in doing this that part of the plate becomes stretched, and causes tension in the surrounding plate immediately connected with the blistered spot. It seems that the only practical way to bend this blister back is by the use of a hammer and anvil. It is humped up and must be humped back again. For a saw 12 to 20 inches, 12 to 16-gauge, a two-pound hammer will do. It should have a moderately rounding face, and be very smooth, and the same is true of the anvil.

If you do not care to buy a set of tools for this, then get a two-pound machinist's hammer, pick out the highest and smoothest place on the blacksmith's anvil, and use it while he is gone to dinner. On this put a thin piece of sheet copper, then strike heavy blows directly on the convex side of the blister and force it down using your short straight-edge. When you get it down level, hammer the saw all over both sides alike on the bare anvil, except where the blister is; do not touch this spot only to true it, using copper blanket between the saw and anvil. By hammering lightly all over the plate you have restored the tension. To judge when this is right, your saw if running at a high speed, should have a little drop to it, that is, the most tension on the edge caused by hammering most near the center. To find this drop or sag, lay the saw down flat, and with the straight-edge applied across the saw at right angles with the support raise the edge next you, and the plate should show 1-32-inch drop at and near the center; turn the saw down, and it should drop the same on that side too; this for about 2,000 revolutions per minute.

In truing up the plate, test all over both sides with the short straight-edge. When you find a round hump, use the round face of the hammer, but if the high place extends in ridge-like form, that is longer one way than the other, use the pene end of the hammer parallel with the ridge. A very dry, hard block of wood, oak or maple, or what is best, *lignum vitæ*, endwise of the grain, is a pretty good substitute for a flat anvil top; indeed, some sawmakers prefer to use this, but I prefer a large flat-top anvil; this always remains in shape and true.

If your saw happens to be center-bound or rim-slack, "fast" as termed by saw hammerers, it should be hammered at and near the edge; this condition is known by the saw dropping near the center too much when testing flat. The tension may be the reverse of this and drop at the edge; by forcing the straight-edge hard down, holding the saw up a little, one edge resting on a support, the edge will fall away, leaving the center the highest. This is overcome, as before said by hammering the plate about one-third the way off from the center in circles, three or four of them both sides alike, on the smooth, hard-faced anvil, with the round face of the hammer.

These rules hold good on large saws, and as far as goes on all metals.

**WHERE TO FIND THE OLD-FASHIONED BUCK-SAW.**

**T**HE buck-saw has gradually gone out of use in cities, in consequence of changing methods of life. Twenty-five years ago cords of wood for the winter's use were dumped into the back yards, which were then deemed a necessary adjunct to every house, to be sawed. With the abbreviated space which the crowding of cities has brought about, this routine would not be practicable nowadays, even if it were desirable. The kindling wood factory, cutting up the log into very small pieces and kiln-drying it for convenient use, is the order of the day.

The itinerant wood-sawyer who followed a load of wood from the wagon stand has passed on. Not so, however, in the country. Many a farmer has his buck-saw, which he uses on rainy days to keep himself busy,

an economy of time at which the agriculturist, if any one, is an adept.

In sections where this is the rule the demand for the buck-saw is as large as it ever was, and in its perfection the saw has ever kept in line with the step of our day. Better sorts are made of what is called "razor steel," which is more in its name than in its approaching the high order which its appellation would signify.

It is, however, carefully selected from high grades; how carefully, being shown by an extra cost of fifty per cent. over ordinary sorts. The bracing of the saw has also reached a point of high technical skill. The middle brace often represents an elliptic in its center, reaching at both ends a solid piece of wood. What is claimed, however, to be superior has the points separately joined in the frame at the handle end, reaching a point solidly in the further upright. This gives a certain spring and strength to the movement, which is in itself a study. Then the frame itself is light, combining all in strength, utility, graceful lines, workmanship, and ease in movement.

Nothing is more laborious outside of the stoke-hole of an ocean steamer than the sawing of wood, and the care and skill with which the saw is made and put together are full of thought to the reflective mind in considering the strides making in this mechanical age.

**HOW TO DRY OAK.**

**A** CORRESPONDENT of the *Scientific American* asks the following question: "Would you kindly inform a reader how to successfully kiln dry oak lumber and not have it warp? We use twelve feet even length, best quality Wisconsin red oak. In piling we have six sticks even thickness two feet apart, foundation of piles perfectly level but the lumber is not straight. With exhaust in day we have one hundred and thirty degrees, live steam at night one hundred and sixty to one hundred and eighty degrees of heat. Sometimes in the middle of drying we allow the kiln to cool down entirely; for instance, stopping Saturday night and not starting again till Monday morning. Does that affect it? What is the right temperature for drying oak when hot air is not used? How is lumber dried with hot air? What degree of heat and what size of blower? How can I figure the pressure of force of any sized blower?" The answer given is as follows: Try turning steam into the drying room at the same time steam is turned upon the coils. Keep the room moist in this way until the lumber gets heated to one hundred and thirty or one hundred and fifty degrees. Then shut off steam from the room and continue the heat with very little ventilation. This will dry the lumber evenly and make it less liable to warp. It is better to have an even heat, and the drying should be finished in a week. It is better for drying oak to heat to two hundred degrees if possible. This you can do with live steam by closing drying room nearly tight during the last of the process. Ventilating blowers give about two ounces pressure to the per square inch. The pressure depends upon the speed.

**A SIMPLE FIRE EXTINGUISHER.**

**I**T IS THE opinion of many that some of the money which is spent by factories, mills, and stores on the introduction of pipes and valves for fire extinction might be saved by the adoption of a much simpler method. Both sulphur and ammonia are well adapted for extinguishing fire. Sulphur absorbs oxygen and forms sulphuric acid, the fumes of which are much heavier than air. The quantity required would be small, since seventy grammes of sulphur can make one hundred cubic metres of air inimical to combustion. An effective sulphur extinguishing apparatus can be made of a large box of moderate depth and open at the top. It should be hinged at one end or one side to a protected ceiling, and kept close thereto by a cord or wire connected with a wire or strap formed chiefly of cadmium fusible at 144° F. Inside the box is placed a considerable quantity of cotton wadding well saturated with powdered sulphurous acid gas is instantly evolved, which extinguishes the fire by rendering the air unfit for combustion.



Keep the lag-bolts and lock-outs of machines tight. Many machines that have become rickety and shake can be made to work perfectly still by attending to them in this particular.

**A Powerful Gas.** A German scientist has discovered a curious gaseous compound, made up of oxygen and hydrogen. It dissolves metals, and with silver and mercury it forms powerful explosives.

**True Economy.**—When selecting pulleys or belts don't be afraid of having the face of the pulley or the belt too wide. Economy will be found in the use of wide belts if not carried to extremes.

Some German engineers have invented a new lining for bearings. It consists of a thin layer of compressed vegetable parchment, and may be made to stand a great deal of use by being occasionally impregnated with mineral oil.

Few engineers will assert that either of the three methods in common use from prime movers to the machines is so good that nothing better need be desired. Toothed wheels, flat belts and endless rope have respectively useful qualities peculiar to themselves, rendering each better adapted to given conditions of work than its companions. Nevertheless none of them claim to be quite perfect.

Oxidation is one great source of deterioration in boilers, and is caused by the air held in the water, the process being intensified by the heat and pressure. That the corrosion of boilers is caused by the oxygen liberated from the water is shown by the fact that its specific gravity is greater than steam nearly double, and therefore it would naturally remain near the water line; and it is found that the corrosion is nearly always at that point.

Mention is made of an ingenious engineer, who desiring better lubrication of indicator pistons, has an internal reservoir formed in the body of the piston, so that the steam pressure acting on the surface of the lubricant, forces it through small outlets into a groove on the other surface of the piston. This piston is thus continuously lubricated, and the oil under pressure in the groove forms a packing, one full of oil lasting, it is asserted, while taking twenty-five diagrams.

The three elements of electrical transmission of power are: (1) The generators, which are placed at the power station, and which are driven by the water wheel or steam engine or other prime mover; (2) the copper conductors, which are placed on poles like telegraph wires, and which conduct the electric current from the generators to (3) the motors, which deliver the electrical energy to all kinds of machinery. The motors are either belted or geared to these machines.

The most effectual remedy for preventing belts from running to one side of the pulley would be to find out first if the face of the pulley is straight; if not to straighten it. In some cases the shafts may not be in line. The remedy in this case would be to slacken up the hanger bolts and drive the hangers out or in, as the case may be, until both ends of the shaft become parallel. This can be determined by getting the centres of the shafts at both ends by means of a long strip of board.

Plumbago has long been regarded with favor by many engineers as a lubricant, and in many places it seems to fit where everything else has failed, noticeably in rough bearings, in which the plumbago can settle and fill up, making a smooth bearing in place of the old one. If this partial use of its lubricating qualities is successful it would seem that a bearing made wholly of this material would be still better, but whether superior to a good bearing lubricated with oil remains to be demonstrated, and considering that self-oiling bearings are now plentiful and efficient, the advantage of no oil disappears.

A correspondent of an engineers' paper suggests that white paint for boiler fronts, smoke stacks and other iron surfaces in the engine room, instead of black, as commonly used is more pleasing and makes a better appearance; besides, it is known that lime is a non-conductor of heat, therefore, whitewash must be considered an excellent material with which to cover the many metal surfaces on which black paint is generally used. He argues that white induces cleanliness, and that there is no argument against its use but laziness.

A considerable saving in repairing saws is attributed to the process of electric welding. It was formerly necessary to cut down to a smaller size any saw from which a tooth had been broken, but it is now only necessary to fit in a new tooth and secure it in place by electric welding. A drop of oil restores the temper. The joint in continuous band saws is also made by this process.

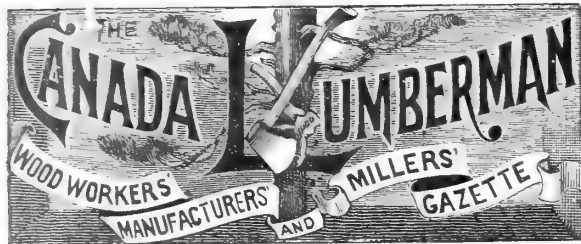

PUBLISHED ON THE 1ST EACH MONTH BY  
ARTHUR G. MORTIMER.

OFFICE:

75 CANADA LIFE ASSURANCE BUILDING,  
TORONTO, ONTARIO.

TERMS OF SUBSCRIPTION:

One Copy one Year, in Advance, - - - - - \$1.00  
One Copy six months, in Advance, - - - - - 50  
Foreign Subscriptions \$1.95 a Year.

Advertising Rates Furnished on Application.

THE CANADA LUMBERMAN is published in the interests of the lumber trade and of allied industries throughout the Dominion, being the only representative in Canada of this foremost branch of commerce of this country. It aims at giving full and timely information on all subjects touching these interests, discussing these topics editorially and inviting free discussion by others.

Special pains are taken to secure the latest and most trustworthy market quotations from various points throughout the world, so as to afford to the trade in Canada information upon which it can rely in its operations.

Special correspondents in localities of importance present an accurate report not only of prices and the condition of the market, but also of other matters specially interesting to our readers. But correspondence is not only welcome, but is invited from all who have any information to communicate or subjects to discuss relating to the trade or in any way effecting it. Even when we may not be able to agree with the writers, we will give them a fair opportunity for free discussion as the best means of eliciting the truth. Any items of interest are particularly requested, for even if not of great importance individually, they contribute to a fund of information from which general results are obtained.

Advertisers will receive careful attention and liberal treatment. We need not point out that for many the CANADA LUMBERMAN, with its special class of readers, is not only an exceptionally good medium for securing publicity but is indispensable for those who would bring themselves before the notice of that class. Special attention is directed to "WANTED" and "FOR SALE" advertisements, which will be inserted in a conspicuous position at the uniform price of 15 cents per line for each insertion. Announcements of this character will be subject to a discount of 25 per cent, if ordered for three successive issues or longer.

Subscribers will find the small amount they pay for the CANADA LUMBERMAN quite insignificant as compared with its value to them. There is not an individual in the trade or specially interested in it, who should not be on our list, thus obtaining the present benefit and aiding and encouraging us to render it even more complete.

SPECIAL ANNOUNCEMENT.

WITH the first number of the thirteenth volume of the CANADA LUMBERMAN, which will be the number of January coming, this journal will appear in an entirely new dress, printed throughout from new type from the leading type foundries of the United States and Great Britain; and the mechanical preparation of the paper, in every particular, will be executed in the best style of the art preservative. We shall allow the paper, when it appears, to "speak its own praise," but it is hardly anticipating too much to say, that we have determined to "get there" with the handsomest printed trade journal the country can produce. The work will be done in our own office, on the premises, and under careful personal supervision.

Advertisers, who purpose making changes for January, will oblige by sending in their matter as early as possible, as the work of placing the journal in new type from cover to cover calls for considerable time.

The distinctly newspaper and literary features of THE LUMBERMAN will be made to keep pace with the mechanical improvements.

COMMERCIAL INFLATION AND THE BUILDING TRADES.

IT is true that not a few shrewd men have made fortunes during the period of a commercial boom. Where this has been the history of one, scores of others, though they made money at the time, let it slip through their fingers when the boom had ceased; for just as surely as night follows day, so comes a collapse as a

sequence of commercial inflation. Few there be who successfully go through the combined periods of inflation and collapse. We need only refer to the history of Manitoba as an instance not far remote, and one that has a forcible lodgment in the memory of many to this date.

We are not forgetful of the fact that it is during these periods of inflation that the greater enterprise is often shown by individuals and communities; and that prosperous cities and towns have an existence to-day, that would never have reached more than the conditions of a village or hamlet, had they not first gone through the hands of the enterprising boomster. The same thing is observable in commercial undertakings of various kinds. How few railroads of any country, that may be paying properties to the present owners, did better for their promoters than land them in bankruptcy. As the pioneer of the forest endures the severest hardships, not infrequently breaking down physically under the strain, while future generations reap the rewards of his toil, a kindred law exists in the world of commerce, which builds prosperously on the work of those who went before, and courageously laid the foundations.

It is not the case that the pioneer always builds wisely and well. More frequently the peculiar spirit of daring and impetuosity that makes him a pioneer has combined with it a certain recklessness that leads him to take chances that the more conservative man would never take. But had there been no Columbus, would there have been a new continent? Where would science be to-day had there not been a Newton to lead the way?

Our own city is not void of some experience, that if not directly, at least indirectly, bears a relation to this line of thought. Last month the news columns of THE LUMBERMAN told the story of a considerable number of local failures in the lumber and building trades. This month adds full as many more to the list, and rumblings are heard of others. These periodic troubles are not uncommon to the building trades, and in no way presage anything alarming to the general lumber trade. But the very fact that from time to time they show themselves the more distinctly is the cause of their existence marked.

A few years ago, real estate operations in Toronto shot ahead with race horse speed. This circumstance gave birth to a volume of speculative building far beyond the requirements of the city. It was undertaken largely by men of no commercial strength, but then the boom was on, and where to-day, loan associations, money lenders and capitalists guard the treasury with the watchfulness of an eagle, then money was plethoric and one did not require a gilt-edge rating to secure either credit or capital. The result: everybody was doing something in real estate and building. The business man, working on a limited capital, managed somehow to extract sufficient money from his business to go into building, confident that he had only to erect his houses and ticket them "for sale," and he would find a customer as readily for them as for the sugar or cotton stored behind his counter, and with a considerably larger profit for his labor. Many did this and did it again, until the time came when it could not be done again. Then followed the pinch that is sure to come when one's capital is locked up in property of the character of houses and lands, that when slow to move are slow indeed. And when the effort to move became desperate, as it would in some cases, then it was found that like the tailor's suitings that had not first been sponged, there was a good deal of shrinkage visible.

What is the explanation? The position is very nicely put by the *Northwestern Lumberman*, discussing the subject not in a local but in a general light.

In periods of dullness, when money is hard to get, and only the very best security will obtain at all, the inclination is to build as little as possible. Even men who desire to make permanent investments of that character will defer them till times are better, as they say. They should rather build when material is cheap, because sales are slow, and dealers are anxious to sell; when labor is plenty and minimum wages prevail. After a lapse of time business recovers from stagnation, enterprise awakens, there is a demand for houses, and the capitalist or speculative builder launches into building with vigor. At the same time prices of building material and

labor advance, and it is nearly impossible to obtain either at the bargains that could have been secured in the previous dull times. The result is that the majority of buildings in all the large cities are erected at a cost that is not justified by the income that can be derived from them during a series of years. In the case of the speculative builder, who starts structures that he expects to sell at a profit before completion, or as soon as finished, he is often caught by the collapse of a boom and his bankruptcy follows, because he has paid too much for material and labor, and probably for the land on which his buildings stand. The cost of the enterprise has been inflated by the boom and when he attempts to secure a loan in dull times, he finds a wide divergence between the expenditure and the security value of his property. In other words he finds he has lost money, and if the loss is equal to the equity he put in at the start, he is a bankrupt at once. Foreclosure of mortgages and forced sales reduce the value of improvements that fall into such ill luck to a level below cost from which they may never recover.

Do these things tell of the decadence of Toronto, as some envious writers proclaim abroad? Not in any sense. They are conditions that have been encountered in the history of the most prosperous cities on the continent. During the period of real estate depression, if we shall put it that way, as noticeable as when the boom was on, Toronto's population increased with marked rapidity, whilst in commercial progress and the construction of public buildings and colossal structures, the property of sound and conservative monetary institutions, never in the history of Toronto has there been like activity.

Present conditions are not without their lessons, and perhaps the lumber trades in some measure can take these lessons home not in any sense do they reflect disparagingly on the possibilities of this great city.

A DUTY PROTEST FROM AMERICAN LUMBERMEN.

ANY fault found with the McKinley bill, in its relations to the lumber interests of Canada and the United States, has so far, come from Canadian lumbermen. It is a new thing to find American lumbermen protesting against the privileges that so many of their own number have been prepared to lay hold of with increasing avidity. But a writer in a United States lumber exchange essays to call upon the "lumber manufacturers and their employees" of this country to "immediately protest to the president and request the re-imposition of the duty removed by the act of 1890, and make such a showing to the next Congress of the United States as will give relief to our manufacturers from a competition that does not benefit consumers of lumber but damages producers."

Canadians, according to this writer, were actually too clever for Uncle Sam and "tricked him into lowering the duty on lumber." The Ohio statesman has usually been credited with being the "smart Aleck" in this deal, but it seems that Miss Canada was really too smart for him.

The increase in the importation of Canadian forest products into the United States within the past year is the circumstance that has set the American writer trembling with fear as to the further outcome. It will be known that it is these same figures that have caused so much concern to Canadian lumbermen. The figures, are these: Importations of Canadian lumber into the United States for the year ending June 30, 1890, \$10,118,198; for the year ending June 30, 1891, \$19,886,358; showing an increase of \$9,768,160.

The argument is that, whilst a few American manufacturers with Canadian interests are benefitted by these conditions, the great body of United States lumbermen are serious losers. The Canadian lumber is brought into competition with the American product, and "the effect of this competition," we are pathetically told "is felt from Maine to Texas and from Washington to Florida."

The writer of the article in question is undoubtedly an ultra-Protectionist, but he may make up his mind that whether the great body of United States lumbermen are protectionists or free traders they are well satisfied with the kind of protection Mr. McKinley has given them in his little bill, as far as Canadian lumber is concerned, and we opine they are ready to go it one better when the opportunity presents itself.

Just before closing our forms we received a well written communication from an esteemed subscriber and well known lumberman, in which the *Northwestern Lumberman's* "bogey" is handled in a vigorous fashion. We publish it in another column.

# EDITORIAL NOTES

THE insurance losses on the lakes for September and October are estimated at \$465,000. The two months taken together are without precedent. We have not the figures beside us at this writing, but it may be noticed that the losses from mill fires this year have been of a most exceptional amount.

THE carpenters in the Sheffield district of England, recently obtained a considerable advance in wages. This had the effect of turning the attention of builders to doors and window frames made elsewhere. Recently doors imported ready-made from Canada have been taken into that district at a cheaper rate than they could be made there, and used in houses now in course of erection in the South Yorkshire district.

THE Hemlock lumber producers, of New York and Pennsylvania, say that trade with them is injured in a measure by the influx of cheap pine from Canada, the importation since the change in duty increasing very largely. There is no doubt about the increase: the fact that the increase has taken place, and is likely to further grow, is the best possible evidence that the tariff change has been generally acceptable to the lumber industry across the border. It may hit the hemlock men a little hard, but the lumber trade as a whole are not likely to squeal.

THE Kingston (Jamaica) correspondent of the New York *American Mail and Export Journal* writes: A good trade, and a profitable trade at that, is to be made in lumber of all kinds if properly attended to. There is a growing desire for improved dwellings in the majority of the West Indian islands, and when it is remembered that the erections are to a great extent made entirely of wood, an opinion can be formed as to whether the market with the West Indies for lumber is worth keeping and worth an attempt to extend it. The Canadians are seeking to make a strong point in this, and have taken no little pains to bring the resources of the Dominion before the builders and merchants in the more important centers of the West Indian islands. Pitch pine and white pine are the kinds most in demand. Shooks or staves and headings are also in good demand at all times, and a profitable business can be done in these if care is taken in the selection.

A GOOD work is done during the winter months by the Women's Christian Temperance Union in providing the various lumber camps of the province with magazines, newspapers and other suitable reading matter. To each Union is assigned the care of a certain number of camps. There is no reason, however, why this work should be confined to Ontario alone, and it may be that it is not. In New Brunswick, British Columbia and Quebec thousands of lumbermen are at work in the woods, and whilst, as is somewhat painfully shown in our interview with Mr. J. S. Murphy, of Quebec, in another page, there are thousands of shantymen who are unable to read, at the same time there are others in large numbers who are not so ignorant, and who doubtless appreciate the kindly acts of this philanthropic organization. More than this, the story as told by Mr. Murphy shows how far short, with all the missionary effort of our churches, christianity and philanthropy have come of meeting the mission needs of our own country.

AN experiment is being made in Paris, France, of a new system of wood paving. It consists of pieces of oak about 4 in. long, split up similarly to the ordinary firewood, and laid loosely on end in fine sand on a bed of gravel from 4 in. to 4½ in. in thickness. A layer of fine sand is then spread over them, and they are alternately watered and beaten several times. In about forty-eight hours the humidity has completely penetrated and caused the wood to swell, and it is claimed that the

mass becomes thus absolutely compact and homogeneous, and capable of supporting the heaviest traffic. In London, Bristol and other parts of England contracts have been let during the past month or so for the laying of considerable wood pavement. The contract in one case calls for the laying of yellow deal blocks, 9 in. by 6 in. on a bed of Portland Cement Concrete. The Puget Sound *Lumberman* alleges that native cedar, if properly laid with fir or hemlock planks underneath, will make the best kind of pavement in the long run. Thus block paving continues to hold its own on both continents.

MUST the saw mill go? A new machine has been invented which it is said will revolutionize the lumber business. This machine cuts lumber without any waste and there is no sawdust whatever. The new invention, which is called the Bradley Draw Cutting machine, is designed to cut thin boards and planks, and will cut in different thicknesses varying from one thirty-second of an inch to an inch. The inventor is Thomas S. Crane, and he and Dr. E. Bradley, who is the principle owner, have been at work on it for five years. The saving in lumber that this machine will effect will be very great. Mr. Lewis said that in small lumber, one-quarter and one-half an inch in thickness, one-quarter of the log is lost in sawdust; then another eighth is lost in planing, and the lumberman in preparing his lumber for use loses three-eighths of the log. This new invention will save all that. The machine cuts cherry, ash, birch and maple, in thicknesses from a sixteenth to a half inch. The machine is intended to be placed in the woods and to cut the trees as soon as they are felled. Green wood is cut more easily than seasoned wood, but logs have been cut with it that had lain in the yard for ten years. The machine weighs forty tons.

LUMBER conditions in the Puget Sound district, Washington, are in a most unsatisfactory shape. Between the lumbermen of Seattle and Tacoma severely strained relations exist, and the result is that these men are, metaphorically speaking, cutting one another's throats by a continued cutting of prices. As is usually the case under like circumstances, at any time, neither party is being benefitted by the cutting. No more trade is being done, and profits are sacrificed to the individual injury of every man in the trade. An attempt will be made to remedy the trouble by the formation of a state organization, when other questions including an adjustment of railway rates, and rules for inspection and grading will be considered. Get together and stick together brethren is the word from your Canadian lumber friends. This doing business on the lines of a Donnybrook fair, each man striving to do the most injury to his neighbor, is silly business. Every man gets hit in the melee. It may be that to realize right profits you may have to wait for a revival of foreign trade, but this will be better than doing business as you are now, just for the fun of the thing. There is money sometimes in what the French term the activity of remaining silent.

CHARLES Stewart Parnell, the Irish statesman whose recent death called renewed attention, was engaged at one time in the saw mill business. This is a fact not generally known on this side of the water. Mr. Parnell began business in the saw mill, timber and stone quarry trade about the year 1873. Two years previously he returned from a tour in America, and determined then to commence in the trades named at the first opportunity. The mills were built on the family estate at Avondale, near Rathdown, county Wicklow, and of course, some stir was made in the neighborhood in consequence, the reasons being that it was somewhat unusual for a landlord to engage in commercial pursuits, and that a new industry was created in the district. But very shortly Mr. Parnell's mind became engrossed in politics, and early in 1874 he took an active part in political affairs, and from then devoted himself chiefly to those concerns. The saw mills, etc., did not stop, however, nor did Mr. Parnell cease to be connected with them. Indeed, up to the time of his death he was connected with the businesses, which are still being carried on. At the works a good deal of native timber is sawn up and manufactured into wheelwrights' goods

and similar articles which are not only sold in Ireland but exported from the country. A brisk trade is done in general turning, but particularly in the turning of brush heads, handles, etc.

THE great feat accomplished last spring by Leary, the enterprising lumberman, in shipping a raft of logs from St. John, N.B. to New York has already been recorded in these columns. Reference has also been made to the intended effort of Chas. H. Moore, of Lock, Moore & Co., owners of timber limits and saw mills at West Lake, La., and who resides at Galveston, Texas, to out do the Leary feat. We have now from Mr. Moore himself more perfect particulars of the methods to be employed in the accomplishment of this feat. He said: I have consulted some of the oldest sea captains in America, men who have crossed the ocean and traversed the coast all their lives. They have perfect faith in my theory and believe that the experiment will be a successful one. In the first place a log raft from Galveston to London wouldn't encounter the severe storms and seas that are confined to the coast from the Bay of Fundy to New York Harbor. Of course it might be possible that a journey across the ocean with a raft might encounter weather more severe than that on the coast but it would be an unusual case. I will choose my weather, making a start from Galveston late next July. The shipment will be consigned to our London house. About three months will be employed in making the raft, which will consist of three sections, firmly spiked together after the plan of a primitive catamaran. The logs of each section will be solidly lashed by heavy cross pieces and spikes. This raft will be built in Galveston harbor and propelled across by the steam tug Storm King and a tramp ocean steamer 3,000 tons, owned by Frederick Leyland & Co., proprietors of the Leyland Line, Liverpool, Eng. The raft will be about half the size of the Leary raft. Ponderous wire cable will be used for hawsers. The raft is to consist of Texas yellow pine, and is intended for ship and house-building. The risk, of course, is great, for if the logs are lost I am out about \$20,000. If the experiment should prove a success I will make my shipments by raft every summer, as it is by this means I save freight, while the action of the water on the timber seasons and improves it.

"BE sure your sin will find you out," is an axiom of high authority that excepts not even the dishonest lumberman. An illustration of recent date is found in the case of D. W. Holt, a lumber merchant, of Phillipsburg, Pa. This man has been placed on trial in a suit to recover \$3,500 paid to him by the Peoples' Fire Insurance Company, of Pittsburg, Pa. There are 16 similar cases against Holt, which will probably be decided by this case. The whole involves about \$120,000. Some time ago Holt's lumber yard at Phillipsburg was destroyed by fire, and he succeeded in recovering \$120,000 insurance. The charge now is that the fire was the work of an incendiary, and that Holt himself was the guilty party. He was further guilty of the fraud of causing his books to be so manipulated that they were made to show about twice as much lumber as he had actually on hand. A. B. Carpenter, a former employe of Holt, has given testimony of a highly sensational character. He testified that Holt had instructed him that when he was making his daily returns to the bookkeeper of the number of feet of lumber he was to increase the amounts each day until the entire amount given made the total about twice that on hand. This done, he said that Holt had made a proposition to him that if he would fire the lumber he (Holt) would give him a quarter interest in the business and 10 per cent. of the insurance, which proposition he admitted he agreed to. Witness then explained how he prepared boxes saturated with oil to fire the yard, concluding as follows: "On the night of August 21st 1882, Holt came to me about 7 o'clock and told me it was time to finish the work up. Holt then left," said the witness, "and I fired the boxes." Carpenter then told how the crime had preyed upon his mind and he could get no rest, day or night, from a guilty conscience; how it had transformed him into an old man, his sufferings finally becoming so great that he went to the sheriff and confessed all.





N. C. DYMENT, of Barric, thinks the outlook for the lumber trade is bright, for the reason that building throughout the country has almost been at a standstill. He approves of the action of the government in removing the export duty on logs because it had the effect of reducing the duty on lumber going into the States.

"Our shipments of oak this year," remarked Mr. Charles McGibbon, the Penetang lumberman, "have been considerable. We are doing a nice foreign trade in hardwoods. But we are taxed \$2 a thousand every time on hardwoods. What was the matter with the government that they did not get down the duty on hardwoods, when they lowered it on pine? What of the log duty, you ask. It is tough on our saw mills in the north. 'Tis too bad that such a quantity of timber should be sent to the other side, that rightly should give employment to labor in our own saw mills. If we had free trade in lumber there is little question but that the Americans would be disposed to plant their mills on our side of the lines, close to their logs."

David Ross, Whitemouth, Man., writes: Being a manufacturer of spruce lumber for the last eleven years, I felt some interest in the action taken by the pine manufacturers of the Lake of the Woods towards the spruce men: and yet I never feared but that the question would right itself very soon. It is well to remember that there are pine men who do not own allegiance to the boycotting process. Such men, I believe, as Dick, Banning & Co. and John Mather do not believe that the process is workable; and although they were willing to accept its blessings, would not shoulder its onus. The trouble with the pine men is that they want the earth, and when they get that they are not satisfied. Your remarks on boycotting are sound and fair to all classes of business, the lumber trade not excepted. The true principles of trade are stronger in their governing influence than the circular issued by the lumbermen of any one section of any one province. This too needs to be remembered in connection with this matter: trade has never been better in Manitoba than this summer, and yet men are found who are not satisfied.

A few days since I had a pleasant chat with Mr. C.A. Larkin, very recently of Brandon, Man. Mr. Larkin conducted a successful lumber business in the Prairie Province for several years, and only disposed of his business there within the past month to become a resident of Toronto. "Business has been splendid in Manitoba all summer," said Mr. Larkin. "We do no export trade, as you know. The business is entirely local, but it is keeping good pace with the growth of the country. I think our methods of doing trade in Manitoba—my reference is solely to lumber trade—is superior to yours in Ontario. We are altogether more exact and careful in the grading and inspection of our lumber. There are about twenty-five distinct grades of lumber in Manitoba. We grade more closely than you do here. For example, in the matter of flooring your people seem to cut all sorts of lengths. We cut to one uniform length, which is more economical to the builder in making up. There is practically no manufacturing of sash, doors or other house building appurtenances in the province. You may think it strange, but we buy everything required in this way from St. Paul, paying 25% duty and then we do better than in Ontario. What influences us in our trade with the States is the fact that we secure just the class of sash and doors suited for the line of building common to this new province. My purpose in coming to Ontario is to engage in the manufacture of these things particularly for Manitoba trade. Since the falling off in export trade in British Columbia, an effort is being made to cultivate the field in Manitoba, but not with very much success. The woods there are not so well

sued for the trade, as what comes from the Rat Portage district. But I can say that there is nothing in its way to equal British Columbia cedar. The polish that is capable of being put on this wood is something surpassing competition anywhere in the world, as far as I am aware."

"I am one of the old pioneers of Canada," said P. O. Byram, of Victoria, N.B. "For fifty years of my life I have been engaged in milling and the lumber business, more or less, and have taken an interest in opening up our wilderness lands. But I find syndicates locking up our lands, and driving population out of the country despite every effort of the pioneer to open them up. What is worse, our provincial and Dominion legislators encourage this slaughtering of our once magnificent forests now fast becoming extinct. You ask why is this done: simply to encourage lumber rings, and secure for the politicians whatever influence they can exert on their behalf. I give you an example of what I mean, and this is one case among the thousands; that might be cited. About forty years ago, I came to this upper country and concluded to open up a settlement on Grand River, Victoria Co. The late Hon. R. D. Wilmott, our respected Governor was then Surveyor-General, and our present respected Governor, L. L. Tilley was also in the government, and I wrote them my desire. At once they sent Mr. Gordon, C. L. Surveyor to run in to the settlement for me when I desired. He staked lots on both sides of Grand River for several miles up. In those days, on all lands laid off for actual settlement, the crown protected the lumber thereon for the benefit of the pioneers. I chose my lots and cut down about fifteen acres and put in a crop. The next year I cleared about five acres more, and did some more planting. In August a frost came and cut the crop down. For two years of hard toil, except about thirty dollars worth of hay, and after having expended four hundred and nineteen dollars, I realized nothing save a small stock of potatoes. I concluded to adhere to the old saying, "where you loose money is the best place to find it." I tried again and met with better success in my farming operations, at same time exerting some influence in having roads opened and settlements started. But the day of the politicians came. Lumber syndicates were formed and lands that were laid out for the settlers fell into their hands. These lands have been operated to a large extent by Americans who stripped the forests of their wealth, removed the logs to their own side of the lines there to be manufactured into lumber in their own mills. The effect has been to dishearten the settlers, and give poor encouragement to the erection and operating of lumber mills of our own. We should exact an export duty equivalent to the American import duty on our manufactured lumber."

Constant experience bears testimony to the accuracy of the saying, that one half the world does not know how the other half lives. We see this exemplified almost daily close to our own doors. I closed an exceedingly interesting interview with Mr. J. S. Murphy, the veteran lumberman of Quebec, a few days since, convinced that there is, as another old saw goes, more truth than poetry in the statement. Mr. Murphy has been a resident of Quebec for 46 years, and has been engaged in lumbering the greater part of his life-time. He has an office in Quebec city and operates a mill and timber limits on the St. John river employing about 300 hands. He knows almost every foot of his native province and relates some interesting history of the conditions of the habitant.

"Do you know," said Mr. Murphy, "that there are thousands of men and women in the Province of Quebec, who have never seen the ancient capital, or put eyes on a railroad. An epoch in the lives of scores of these people, was the occasion a few years ago, when a local railroad extended its ramifications into these backwood's settlements. It was a great day for the small boy, while the older boys, who took advantage of the opportunity to see how the steam horse could pull them along, had a lively time, though they came back to the woods, many of them, with heads increased in size as a result of too close acquaintance with some of the blessings of modern

civilization. These people live in the most primitive fashion. Their domicile is usually a log house, with no lack of occupants to fill every nook and corner. The average family of the French shantyman, consists, I suppose, of fifteen or sixteen junior shantymen. The counsel of Holy writ to be fruitful and multiply and replenish the earth is religiously practiced by these people. You say it must take a good deal to fill the mouths of families of this size. It does, and it is surprising how little it is done on. Each family has a patch of a garden, where, if the season is at all favorable, a crop of potatoes and other vegetables is grown, which goes a good way towards tiding them over the winter. In summer, work is found chiefly in the mills, where fair wages are earned. This lasts about six months of the year. In winter a certain number of men go into the woods, but employment of course is not found for all. From \$10. to \$12. a month is paid the men in winter, and from \$5. to \$7 to boys of sixteen and seventeen years of age. This is exclusive of their board. We feed them well, not with the dainties you are accustomed to get in Toronto, but good, substantial food and abundance of it. It is undoubtedly a monotonous life, yet these people taking them altogether seem happy and contented. Thousands of them can neither read nor write, but I am glad to say that of late years through the efforts of missionaries and various philanthropic organizations a change is being made in these respects; but the field is a wide one to cover.

"The fact that work cannot be found in winter for large numbers of these people has caused the removal of thousands of them to Massachusetts, where not only the men, but also the women and children find work in the cotton factories.

"To leave this phase of lumbering and replying to your enquiry as to the condition of trade in Quebec, I may say," continued Mr. Murphy, "that trade during the season just closed was very dull. One hundred and fifty six cargoes of lumber less than last year left our ports, representing in money about \$3,000,000. This is a considerable reduction in one season's business. The competition of the Baltic has affected our English trade of late years. Cheap as one may think labor in Canada, we cannot commence to compete with foreign labor. On the Baltic, women work in the lumber mills, doing work that we would consider altogether beyond the physical ability of the sex, receiving eight and ten cents a day. It is chiefly a poor grade of lumber that reaches England from these ports, but it is sold at a price so much lower, relatively than ours, that Canadian forest products are at big disadvantage. Where one vessel leaves Canada for England, six leave the Baltic ports and we find this circumstance operates seriously against trade here.

"Yes, I am hopeful that the building of the new Manchester ship canal will help our trade with England. In fact I know where a beneficial effect has already been experienced by Canadian dealers. Lumber for Manchester will now go direct from Canada, and not as hitherto, first to Liverpool and then undergo additional carrying expense before reaching Manchester. We will likely do an increased trade with Manchester. Freights have run high this year and that has had a hurtful influence on trade with England. As many as fifteen or twenty vessels loaded with lumber from Canada have been lost during the year.

"Trade with the United States has been good. I ship all my spruce to Troy, Albany and Burlington. Have done so for years and established a good trade at these points. We ship of course altogether by water, which makes our season short. Towards the close of the season freights to American ports went up from \$2.25 to \$3.50 thousand. This led American lumbermen, who had bought our lumber, to order it to be held here until next spring. We get \$7.00 for coarse and \$12.00 for better grades in Quebec.

"Though the season closed has been dull we anticipate a marked improvement in business in the spring. The lumber trade in England, which has been more than dull for a year past, shows encouraging signs of improvement. Our stocks of lumber are low, there will be a good work done in the woods this winter and all these conditions portend better things. Prices will, I think, hold firm.

[WRITTEN FOR THE CANADA LUMBERMAN.]

**GUIDING PRINCIPLES OF LABOR AND CAPITAL.**

THE best time, it has been said, to prepare for war, is when a nation is at peace. The time to discuss the relations of labor and capital is not when the mind is inflamed by the passions that seldom fail to be roused during the prevalence of a strike, but when business is going on undisturbed, and the workman in the shop, and the employer in his office are doing with all their heart the work that is nearest to them.

We do not suppose that, on general principles, any reasonable person will dispute the right of either employer or employee to become members of an association organized for the purpose of advancing interests common to those identified with their particular calling. Capitalists and employers of labor, we are led to think, would be serving their own interests better, if they got together more frequently than is the practice with the majority of tradesmen at the present time. In every branch of business questions are constantly arising, that can only be settled right, after careful and united consideration by everyone interested in the particular trade concerned. This getting closer together occasionally would lead to improved methods of doing business, a removal, measurably at least, of some of the results of present day competition, an increase in profits in some cases, where business is being done almost for nothing, and would be the means of creating a spirit of amity and fraternity, that in this break-neck-age is to be preferred to the diamond cut diamond policy that is too much the vogue. Briefly put the old illustration of the strenght to be found in the bundle of sticks has its application to the commercial world.

When purposes of this character bring business men together, whether they be lumbermen, millers, manufacturers, or merchants, good must be the result. If the object is to combine in any manner for the oppression of the employee, to take unfair advantage of certain favorable conditions of trade in existence at the time, and thus bear tyrannically on the people of a community in general, then occasion is given to employ means to subvert these ends.

Workingmen, and we include those of any class, who work with hand or head, and we may use the term in its generic sense, embracing all men and women, who work for a livelihood, have an equal right with the employer to band themselves together into organizations for mutual improvement, mental and social, and that they may be in organized shape to resist attempts that might be made to deprive them of their rights and freedom, providing always, that only manly and honorable means are employed to accomplish the end desired, and that these means, even though approved of by a majority of the assembly or society, by whatever name it be called, do not operate unfairly against any one or more of their own members or workmen engaged in that trade.

When workingmen's societies get away from these leading principles, they resign cause for the sympathy and support of all worthy people just as much as the capitalist does when he uses his position and opportunities for personal aggrandizement, regardless of how others may suffer.

Stating the case in these terms, without pretending to enter into an elaborate discussion of the labor problem, we refer to one question only, but one that probably more than any other is the cause of frequent ferment in labor circles, and which if rightly solved would itself solve others. What is a day's work? Custom has fixed it at various lengths. The government employee has sometimes done his work without doing it. He may even be pursuing another vocation, but manages to draw his day's pay. The bookkeeper in the office, clerk in the store, mechanic at his bench, lumberman in the mill may work six, eight, ten, twelve or even fourteen hours a day. Custom has no absolutely fixed rule, nor can custom correctly make a rule. A day's work is measured by the work a man does within that day, whatever the time-keeper's record may show. Two men may work in the same shop, commence work together and drop their tools at the ringing of the same bell. One may have worked fifty per cent. longer than the other during the same time.

The case has been squarely stated by the head of a

large painter's firm, where the eight hour rule prevails. He said:

When a painter comes to me for a job I ask him if he is a first-class workman, and if he belongs to the painter's union, to both of which he invariably replies in the affirmative. Well, then, say I, your union makes two demands of me, and I will only make one of you in return. Your union says that you must be paid \$3.50 a day, and that the day's work must be only eight hours. Now, my one demand of you is this, that you will give me in return for eight hours work at \$3.50 day an able bodied man's work. I have discovered after repeated experiments that a skilled, able-bodied painter can paint eight rooms with one coat of paint in a day, and I demand of you to paint eight rooms a day or else you needn't begin work.

Some of the fellows who want work, when they hear my demand, shrug their shoulders and say, "Well I'm no steam engine," or "I'm no horse," while others who are more good-natured say they are willing to make a trial. I find, however, that a majority are not able to do eight rooms in a day. Some do seven, some seven and a half, and some only six. All men, however, who cannot do eight rooms are paid off, and only those who can put one coat of paint on eight rooms are retained. The work is not impossible to be done. I have one man who can do thirteen rooms in a day if he wants to but I only ask him to do eight. I would rather pay an able-bodied man \$4 a day than \$3.50 if I can get the man I want.

The point where workmen's unions stumble most seriously is just here. No attempt is made to grade their workmen, and the man whose habits have led him into every excess, rendering him wholly unfit to do "eight rooms a day," adhering to the painter's illustrations, is as good a man in the eyes of the union, as the sober, industrious, studious fellow, who aspires to be a peer in his trade, doing with his whole heart, whatsoever his hands find to do.

No employer of labor will object to pay this man, but there is neither business, or common sense, in the demand of the labor union that insists that good, bad, and indifferent workmen shall be dealt with alike. When a workman goes into a shop to buy goods he does not obtain cottons and silks, tweeds and broadcloths at the same price. He will pay more for one than another because the value is there. Is not the workman who paints eight rooms a day, worth more than the man, who paints only six rooms? The surprise is that the intelligent workmen do not realize the dead weight that is placed on their talents and energies by the existence and practice of this rule, which is general to workmen's unions of all trades.

Strikes will be fewer when this law is amended.

**A BATCH OF FAILURES.**

NOVEMBER will be noted in lumber circles in Toronto, as following on the heels of the preceding month, with another batch of failures, chiefly of builders. In our editorial columns we have discussed the question of these periodic troubles at some length and believe that the reasons there assigned for their occurrence are correct.

The case of Bryce Brothers is probably the most important among the builders, though in many circles not unexpected. Three months ago, without giving names, we referred to a large local firm that was in deep water. The reference was to Bryce Bros. They carried on a lumber business, and besides doing a large amount of speculative building a few years ago, also held contracts in building from the Public School Board, and have done considerable paving, both board and asphalt about the city. H. H. Williams has been appointed receiver, and is busily engaged endeavoring to get the estate into better shape.

Charles McClelland, a speculative builder at Parkdale, carrying on business in the name of his wife Mary McClelland has assigned to E. R. C. Clarkson, who has been instructed by the creditors to wind up the estate. Liabilities \$34,600 with nominal assets \$38,000.

C. Spencer & Son, which means Charlotte Spencer and John William Spencer, the former being the wife of A. Spencer, who failed some years ago, have made an assignment to D. D. Christie. Assets \$2,713.10, and Liabilities \$1,400.70. The firm have a number of contracts out and if these and the other assets realize as expected, the estate will probably pay 100 cents on the dollar.

James Leighton, builder, has a lot of property on his hands, which is unsaleable, and he is consulting his creditors. Nominal assets \$18,000, and \$12,000 liabilities. A committee of creditors are investigating his affairs.

T. & R. Robertson and Hannah Mould are the name of two other building concerns, in a small way, that made assignments before the month of November ended.

Samuel Davidson, dealer in small lumber, has assigned to E. R. C. Clarkson. The estate is a small one.

A big failure is reported from Richmond, Quebec. Mr. J. C. Bedard, who for many years has carried on a large lumber business in Richmond, has assigned with liabilities of 50,000. Mr. Bedard is supposed to have lost a lot of money lately in lumber and also in slate quarries. His assets are not yet known.

The most important failure in lumber lines during the month is that of Tennant & Co., of Dock No. 3. The firm is composed of Mrs. J. Tennant and H. & A. Colwell. The direct liabilities amount to \$20,000, and the assets are estimated at \$15,000. The chief creditors are: Beck Manufacturing Co., \$2,200; Conger Lumber Co., \$2,000; Mickle, Dyment & Co., \$2,100; Peter Robertson & Co., \$1,400, and Playfair & Co. \$1,400. The firm have made an offer of 50c. on the dollar which is now being considered by the creditors.

A number of small failures in different parts of the Dominion are recorded in our regular news notes.

**NEW MULTIPLE SPINDLE BORER.**

THE Cant Bros. Co., of Galt, have just brought out a new Multiple Spindle Boring Machine, which is designed for accurate and rapid boring, being specially suitable for dowelling joints, table leaf work, furniture work, church furniture, school seats, etc. The frame is of iron, well braced and planed perfectly true. The mandrel frames slide on planed ways. Each mandrel frame is independently adjustable to and from the other by means of screws and crank, each mandrel being driven by an independent belt. The table works on planed ways, and is raised and lowered by means of bevel gears and screws operated by a crank and parallel shaft below. The treadle is connected to the table by adjustable rods to regulate the throw of the table, which is moved forward to the boring bits when the treadle is pushed down by the foot, and which returns to its original position when the treadle is released. The clamping device on our machine is entirely new, the work being held down by four eccentrics which are operated by one handle, so that along with the new stop it is impossible to bore the holes out of line. For extension table work our machine surpasses anything yet made. The machine can be made with one, two, three or four spindles, and will bore holes from 4 inches to 4 feet apart.

**PROTECTING THE BELTS.**

ABOUT the first thing I did after taking charge of this engine, says a writer in an exchange, was to rail it in and to box in the belt. Any one who has had the misfortune to be present on the occasion of an accident to some poor unfortunate who has slipped and been crushed in the fly-wheel pit, or who has been caught by a belt and had his arm torn out of the socket, will be more than ordinarily anxious not to have such an accident happen to him, or any one in his presence or on his premises. In some countries there is a law about boxing in all wheels, shafts, belts, &c., which by any means may be the cause of death or injury to careful or even to careless people. The careless people have as much right to life as the careful ones have; they are just as much loved and their earnings may be as necessary to some one's support as though they were the most cautious and practical persons on the globe. And after all, it is not necessarily the careless men who get caught. The most careful may slip on a greasy spot, or may be seized with vertigo, or be absent-minded by reason of trouble at home. By boxing in dangerous things, you never have any terrible scenes to haunt you.

J. H. Chaloner, lumber dealer, Lauder, Man., had his stock damaged by fire.

McLellan & Black, lumber, West Brook, N.S., have dissolved.

F. Tremblay's saw mill and sash and door factory, Montreal, Que., was destroyed by fire on 29th ult. Loss, \$32,000.

## THE NEWS.

## ONTARIO.

Wm. K. Snider, lumber dealer, Wilkesport, has assigned.

The mills at Longford Mills have shut down for the season.

—Joy & Son, Napanee, have completed a large addition to their saw mill.

Barrett Bros. are pushing ahead with their new mill at Maganettawan.

—J. W. Anderson & Co., shingle manufacturers, Lanark, have assigned.

—Dickinson's mill at Staples is closed; Ainslie's stove mill at the same place is busy.

—Omyer Bros., of Holland Centre, have sold their saw mill to Mitchell Bros., of Berkley.

—The rains of November have helped the securing of logs that had moved very slowly before.

—De Blaquiere's shingle mill at Leg Lake, recently destroyed by fire, is in course of re-erection.

—The Longford Mills Lumber Company have four camps this winter and expect to cut 12,000,000 feet.

—Large quantities of shingles are being shipped from South River, for the Shannon Shingle Co., of Toronto.

—Mr. McEachern, of Maganettawan, is at Burks Falls busily engaged shipping his summer's cut of lumber.

—The Rathbun Company, Deseronto, have shipped a carload of doors and sash primed and glazed, to South Africa.

—The remainder of the paper wood which was "hung up" in the Thessalon section is being removed by the steam barge *Lindsay*.

—The Buell, Hurdman Company have purchased a locomotive from the Eddy Company, and have leased one of their lumber yards.

—The cordage factory at Brantford has been purchased by the Consumers Cordage Company, of Montreal, Que. The price paid is understood to be \$150,000.

—John Galbraith's mill, a few miles from Emsdale, cut 67½ thousand shingles in one day, thus beating all other shingle cutting for one saw, by 54 thousand.

—Rumor states that the Georgian Bay Lumber Co. have bought Messrs Burton & Bros.' large mills at Byng Inlet North for, in the neighborhood of, \$110,000 cash.

—Considerable trouble is experienced from low water in the vicinity of Lakefield, and mill owners are realizing that prompt measures will have to be taken to remedy the evil.

—Messrs Burton & Bro., of Byng Inlet have shipped nearly 16,000,000 ft. this season, and their mill (one circular and gang), closed down on the 18th of November, having cut over 15,000,000.

—Mr. Gascien's barge, lumber-laden, on her way to Oswego via Rideau canal sunk off Kingston. No lives were lost. Mr. Gascien is a resident of Hull. The barge is one of D. Murphy's & Co's.

—Valee, an Ottawa shantyman, in a dispute about a woman, bit the whole nose off a half-breed hackman named Soucie. The nose was sewed on, but refused to reunite; inflammation set in and Soucie's death is expected.

—The water in the log pond at the Big Mill, Deseronto, has been so low that logs have had to be drawn over the mud to the slides, a state of things never known before. The mill has had an excellent year's trade.

—The Conroy mills at Alymer, Ont. are still running, nearly two hundred men being employed there. The cold weather will likely put a stop to operations this week, when all the employees will be sent to the shanty by the firm.

—The steam saw mill at Carleton Place, of William Caldwell, of Lanark, was shut down recently, the logs and limits having been exhausted by the 22 years of ceaseless havoc among them. Seven hundred chains were gathered up at the wind up.

—The steamship, *City of Midland*, left Byng Inlet, Nov. 21st for Parry Sound. Midland and Collingwood having a heavy cargo of old iron and about 60 passengers. She makes her last trip for this season next week, which will close a successful season's business.

—Paul Huffman, saw mill owner of Northfield Centre, has assigned, but his creditors have ordered the assignee to carry on the business until the two law suits he now has pending are decided. If he wins, the creditors will be paid in full. If he loses, the estate will barely pay 20 cents on the dollar.

The following advertisement in a Toronto paper duped several score of workmen: "Wanted—50 men for lumber

woods, wages \$26 to \$35, board and fares paid. Apply 45 Wallace-ave., near Dufferin-st., after 5." The men paid the advertiser a commission of 25 cents, and they were to report at the Union Station for transportation. The men turned up, but no agent.

—The *Thessalon Advocate* says:—Very little lumbering will go on on the Manitoulin this winter, the McKinley tariff having killed the cedar industry. A few logs will be got out at Kagawong. Conlin and Walsh have got the timber on the Indian reserve at Manitowaning, and will operate extensively; this will not help the village much, as the supplies will be got at the Indian stores a Wikemikong. Very extensive operations will be carried on at Webbwood, and that village will boom this winter.

—Tenders were opened on 7th ult. at the Crown Lands Department, pursuant to advertisement, for the purchase of an estimated quantity of 32,500,000 feet of timber damaged by fire during the past summer, viz., projected berth 66 and part of 65 on the Vermillion River. The prices realized were something over \$3 per 1,000 feet, board measure, by way of bonus and in excess of Government dues. Messrs. Booth and Hale of Ottawa were the successful tenderers. The commissioner considers the sale a very good one.

—A Rat Portage correspondent writes: "The sawing season of 1891 has now closed, all the mills in the district having shut down. The planing mills are still going and lumber being shipped, but orders have eased up somewhat lately. Several outfits have been sent out to the bush by the local mills, and this week the *Kempiner* left for Reed River having a barge and outfit for D. E. Spragge, of Winnipeg. Spragge's limits are on the Rosseau river, and the logs are driven down to the Red river, but for his getting in supplies the portage is preferred, as it is between twenty and thirty miles distant, as against about one hundred miles by way of Winnipeg. Dick, Banning & Co. are having repairs and alterations made in the head gates for their water supply. Mr. Dick being here to look after the work."

## QUEBEC.

—Leon Ravary, saw mill, St. Clet, has assigned.

—DuGrenier & Gagnon, saw mill, etc., Racine, have assigned.

—Ross Bros. are rebuilding their large timber slide at Buckingham.

—Three car loads of new machinery have arrived for the E. B. Eddy Coy's new paper mill at Hull.

—J. Allaire, lumber and tannery, St. Boniface, has sold out his lumber business to Edward R. Lloyd.

—Extensive alterations are being made in the pulp works of the Buckingham Manufacturing Co., Buckingham.

—Twelve square timber camps are at work in the locality of Portage du Fort which is a half more than last winter.

—Thomas Lyon has contracted with Ross Bros., of Buckingham for the making of about 1,000 pine logs. He will also go heavily into spruce.

—8,000 feet of lumber and 8 kegs of nails were used in the scaffolding required for the building of the big chimney for Mr. Eddy's factory, Hull.

—The employees of the E. B. Eddy sulphide works Hull, wear a neat nickel plate on their hats, bearing the inscription "E. B. Eddy, Sulphide."

—George Smith has shipped since the 1st day of October about 50,000 feet of basswood and ash lumber from Campbell's Bay, Pontiac Co., to the Rathbun Company, Deseronto.

—Roderick C. Carter, dealer in lumber, Montreal, has ceased to do business under the name of the Montreal Lumber Co., and has now registered under the name of the Brosseau Company.

—E. Morency, a lumber dealer in a small way at Quebec, has assigned. He is a steady man who has been in business 10 or 12 years doing a moderate trade and under small expense. And yet he has not been able make both ends meet.

—The members of the firm of J. Gilmour & Co., lumberers of Ironsides, have dissolved partnership, and the business will be carried on in the future under the name of Gilmour & Hughson. The members are John Gilmour and W. C. Hughson, of Albany, N.Y.

—The McLaren Manufacturing Company, limited, Montreal, on the demand of the Lachute Lumber Company, have gone into liquidation. The lumber company, represented by Messrs. Archibald and Foster, presented a petition to Mr. Justice Gill asking for a winding up order and the appointment of a liquidator. The petition was granted. Mr. Alex. Caldwell has been named provisional liquidator.

—Last summer when Ross Bros., of Buckingham lost connection with their Basin piling ground by way of the water

slide, they decided to pile their lumber for the future in the town, expecting that the C.P.R. would offer some inducements in the way of sidings and fair freights. After waiting until now for some sign from the company they have gone back to their first love and are now actively engaged in the work of restoring the connection. The C.P.R. will not only refuse to build the siding but will not even furnish cars to ship what is already ordered out.

—A jobber paid a visit to one of the Quebec lumbering establishments to make the customary arrangements before commencing bush operations, and was greatly surprised to learn that the standard log in vogue this year according to the principle laid down by the Quebec Government must contain 249 feet board measure instead of 200 feet as formally. "Well, it does beat all," he said, "I have been chucked out of a job at the mines because they say the mining tax compels them to stop working, I thought I would go in for jobbing at logs this winter, but an additional fifty feet on the standard log for the same money as usual settles that spec. I think Mr. Mercier wants to run us out of the country altogether."

—John Hannigan, lumber merchant of Desrivieres, is endeavoring to effect a settlement at 20 cents in the dollar on his personal liabilities of \$45,000. He is a large shipper of hard wood lumber to the United States, and was one of the principle promoters of the Rapid Manufacturing Company, of Bedford, which collapsed ignominiously a year ago. He held 419 shares in the concern and, in addition to this, endorsed heavily for James Crothers, the president, who left with his affairs in bad shape. He owns a good deal of real estate, but his bankers have a lien for \$34,000 on it to cover his endorsements, and it is doubtful whether his estate shows more than the percentage offered.

## NEW BRUNSWICK.

—John Kilburn has been in Fredericton securing men for his Quebec camps.

—Two new mills for the manufacture of spools are in course of erection in Northumberland.

—A shingle mill is to be erected just below Campbellton, on the line of the Intercolonial by David Richards, who has been lumbering on the Restigouche for several years.

—Large numbers of men are in the woods, and the prospects are that as large a cut will be made this winter as last, if not larger. Cedar, especially, will be got out in large quantities.

—Between 4,000,000 and 5,000,000 feet of spruce, and 5,000,000 or 6,000,000 feet of cedar will be cut on the Restigouche this year. The manufacturing of shingles has become quite an industry on the north shore.

—The St. Lawrence Lumber Company at Bathurst are pushing ahead the work of rebuilding on the site of the mill recently destroyed by fire. The new mill is to be completed by the opening of navigation next spring.

—A shingle mill is to be built at Marysville, near the Canada Eastern track. The land owned by Mr. Gibson, lying along the track, has an immense amount of cedar of the best quality, and the railroad will be used to bring the lumber to the mill. This will necessitate the building of a number of additional dwelling houses in the town. The building will be 60x100 feet, and the engine 160-horse power. There will be space for 12 shingle machines, but only eight will be put in at present.

## MANITOBA AND THE NORTHWEST.

—The mills at Norman, Man., are shipping considerable sawdust for the C.P.R.

—All the saw mills at Norman, Man., are now closed with the exception of Cameron & Kennedy's day shift.

—Ironsides, lumber dealer, Thornhill, Man., has sold out his lumber business. He intends going into the butcher business in Miami.

—Many mill hands in Manitoba, now that the mills have closed down, are engaging in threshing operations in Manitoba and North Dakota.

—It is rumored that a company is about to take over the Ross, Hall & Brown water power at Norman, Man., and erect a mammoth paper mill here, unless Rat Portagers give a \$15,000 bonus to remove it to their town.

—H. Crowe & Co., have sold out their lumber business in Winnipeg, Man., to Jas. M. Hall, of Rat Portage, who was lately connected with the Western Lumber Co., of that place.

—The partnership existing between John E. Campbell and Andrew R. Stevens, as lumber dealers in the villages of Carman and Glenboro, Man., has been dissolved by mutual consent. John E. Campbell takes over and will continue the Carman business. A. R. Stevens will continue the Glenboro business.





TRADE REVIEW.

Office of CANADA LUMBERMAN, Nov. 30, 1891.

THE GENERAL SURVEY.

LOCAL lumber trade has been disturbed by a number of failures during the present month, principally of builders in a small way.

Country trade is quiet. Though the crop is heavy and good prices have prevailed throughout the season, yet for various reasons, it is not being marketed quickly.

Shipments to the United States continue active, and there is an outlook for a fairly active trade with this country the winter through.

Mills are practically closed down all over, and operations in the woods are in full swing. It will be noted from our Ottawa letter, that in the Ottawa district, fully 2,000 more men are at work in the bush this year than was the case last year.

NEW BRUNSWICK.

Trade holds a sort of dog trot position as the season comes to a close. Dealers are commencing to count noses and compare figures with those of former years.

MANITOBA.

The season now closing will be known in the province as one of the most prosperous in its history. This remark applies to business in general, and assuredly includes the lumber trades.

BRITISH COLUMBIA.

Trade in the province this month has had a strong leaning to the quiet side. The season of course is well advanced and this is an explanation in part, but yet it is not a full explanation.

Northwest has also dropped off to a noticeable degree. Freights are weak and have shown a steady decline during the month. Quotations are as follows for cargo lots for foreign shipment, being the prices of the Pacific Pine Lumber Association.

Table listing lumber prices: Rough lumber, per M. \$10 00; Best quality dressed lumber, per M. 00 00; Second " " " 00 00; Laths, per M. 2 50; Shingles, " " " 2 25.

UNITED STATES.

Touching immediate trade, it is evident that the business of the month at the leading lumber centres has been circumscribed, as compared with last month. This is hardly disappointing. The near approach of winter usually has the effect of curtailing the general demand for a product like lumber.

FOREIGN.

Australian trade says Lord, Hughes & Co., in their last circular has relapsed into its former dull state, the slight improvement noted in a former circular, not having been sustained.

A Glasgow, Scotland, report says that prices for walnut and whitewood have considerably declined during the last three months. Small and inferior wood has been imported greatly in excess of market wants.

Denny, Mott & Dickson, of London, Eng., in circular of November say: The improved tone in most branches of the trade has been well maintained during the past month, the partial settlement of trade strikes having further conducted to the confidence of holders.

Toronto, Ont.

TORONTO, Nov. 30, 1891.

CAR OR CARGO LOTS.

Table listing Toronto lumber prices: 1 & 1 1/2 in. Cut up and better. 32 00 33 00; 1x10 & 12 dressing and better. 18 00 20 00; 1x10 & 12 mill run. 13 00 14 00; 1x10 & 12 dressing. 14 00 15 00; 1x10 & 12 common. 12 00 13 00; 1x10 & 12 spruce culls. 10 00 11 00.

Table listing various lumber types and prices: 1x10 & 12 mill culls. 9 00; 1 inch clear and picks. 24 00 25 00; 1 inch dressing and better. 18 00 20 00; 1 inch siding mill run. 14 00 15 00; 1 inch siding common. 11 00 12 00; 1 inch siding ship culls. 10 00 11 00; 1 inch siding mill culls. 8 00 9 00; Cull scantling. 8 00 9 00; 1/2 and thicker cutting up plank. 22 00 25 00; 1 inch strips, 4 in to 8 in mill run. 14 00 15 00; 1 inch strips, common. 11 00 12 00; 1 1/2 inch flooring. 14 00 15 00; 1 1/2 inch flooring. 14 00 15 00; XXX shingles, 16 in. 2 30 2 40; XX shingles, 16 in. 1 30 1 40; Lath, No. 1. 1 70 1 90; Lath, No. 2. 1 70 1 90.

YARD QUOTATIONS.

Table listing yard quotations: Mill cull boards & scantling. 10 00; Shipping cull boards, miscellaneous widths. 13 00; Scantling & joist, up to 16 ft. 13 50; 18 ft. 15 00; 20 ft. 16 00; 22 ft. 17 00; 24 ft. 19 00; 26 ft. 20 00; 28 ft. 22 00; 30 ft. 24 00; 32 ft. 27 00; 34 ft. 29 50; 36 ft. 31 00; 38 ft. 33 00; 40 to 44 ft. 37 00; Cutting up planks 1 and thicker dry. 25 00 28 00; board. 18 00 24 00; Dressing stocks. 16 00@20 00; Picks Am. inspection. 30 00; F. M. 1 1/2 in. flooring, dres'd. 26 00 30 00; 1 1/2 " " rough. 18 00 22 00; 1 1/2 " " dres'd F.M. 25 00 28 00; " " undrs'd B.M. 16 00 18 00; " " dres'd. 18 00 20 00; " " undres'd 12 00 15 00; Beaded sheeting, dressed. 20 00 35 00; Clapboarding, dres'd. 12 00; XXX sawn shingles per M. 2 60 2 70; Saw Lath. 1 90 2 00; Red oak. 30 00 40 00; White. 37 00 45 00; Basswood, No. 1 & 2. 28 00 20 00; Cherry, No. 1 & 2. 50 00 60 00; White ash, 1 & 2. 24 00 35 00; Black ash, 1 & 2. 20 00 30 00.

Ottawa, Ont.

OTTAWA, Nov. 30, 1891.

Table listing Ottawa lumber prices: Pine, 1st qual. M. \$35 00@40 00; Pine, 2nd " " 25 00 28 00; shipping culls 14 00 16 00; Pine 4th qual. deals 10 00 12 00; mill culls. 8 00 10 00; Laths. 1 25 1 50.

Montreal, Que.

MONTREAL, Nov. 30, 1891.

Table listing Montreal lumber prices: Pine, 1st qual. M. \$35 00@40 00; Pine, 2nd " " 25 00 28 00; Pine shipping culls M. 13 00 16 00; Pine, 4th quality deals M. 10 00 12 00; Pine, mill culls, M. 8 00 10 00; Spruce, per M. 6 00 12 00; Hemlock, lumber. 8 00 10 00; Hemlock timber. 13 00 14 00; Ash. 13 00 25 00; Basswood. 12 00 20 00; Oak, per M. 40 00 60 00; Walnut. 60 00 100 00; Cherry. 60 00 80 00; Butternut, per M. 22 00 40 00; Birch. 15 00 25 00; Spruce timber. 13 00 16 00; Hard Maple. 20 00 21 00; 1 1/2 Lath. 1 60 1 90; Shingles, 1st, per M. 3 00; Shingles, 2nd, " 1 25 1 50.

St. John, N. B.

ST. JOHN, Nov. 30, 1891.

Table listing St. John lumber prices: Spruce deals. \$12 00; Pine. 15 00; Deal ends. 6 00; Scantling. 10 00; Spruce, extra. \$3 50; clear. 3 00; No. 1 extra. 2 25; Pine. No. 1. 1 25; No. 2. 1 25; Spruce, extra. 35 00; clears. 45 00; 2d clears. 35 00; Spruce, extra. 24 00; clears. 23 00; No. 1. 15 00; No. 2. 10 00; 6 in., No. 1. 12 00; No. 2. 10 00; Staves. 3 00@4 50; Heading 17 in. per pr. 04; 18 in. 04 1/2; 22 in. 05 1/2; Spruce boards. 12 00; Pine. 12 00@40 00; Oak. 40 00; Ash. 15 00@25 00; Hemlock. 7 50; Shingles. Pine No. 1. 1 25; No. 2. 1 25; Clapboards. Spruce, extra. 24 00; clears. 23 00; No. 1. 15 00; No. 2. 10 00; Flooring, Dressed. 6 in., No. 1. 12 00; No. 2. 10 00; Miscellaneous. Laths. 1 80; Pickets. 6 50@15 00; Railway ties.

New York City

NEW YORK, Nov. 30.—Canadians are interested in the white pine trade, and it can be said of white pine in this market that it fully holds its own. At this time of the year no large demand is expected, but a good general demand prevails, and prices are firm and with a leaning towards stiffness.

White Pine—Western Grades.

Table listing New York City lumber prices: Uppers 1 in. \$44 00@45 00; 1 1/2, 1 1/2 & 2 in. 46 00 47 00; 3 & 4 in. 55 00 58 00; Selects, 1 in. 40 00 41 00; 1 in, all wide. 41 00 43 00; 1 1/2, 1 1/2 & 2 in. 43 00 44 00; 3 & 4 in. 52 00 53 00; Fine common, 1 in. 36 00 37 00; 1 1/2, 1 1/2 & 2 in. 38 00 40 00; 3 & 4 in. 46 00 48 00; Cutting up, in, No. 1. 28 00 30 00; No. 2. 21 00 23 00; Thick No. 1. 29 00 32 00; No. 2. 24 00 26 00; Common, No. 1, 10 & 12 in. 22 00 23 00; No. 2. 20 00 21 00; No. 3. 17 00 18 00; Coffin boards. 20 00 28 00; Box, in. \$13 50@14 00; Thicker. 14 50 15 00; Ceil'g, base, fig. No. 1. 40 00 42 00; No. 2. 35 00 37 00; No. 3. 24 00 26 00; Shelving, No. 1. 30 00 32 00; No. 2. 25 00 27 00; Molding, No. 1. 36 00 37 00; No. 2. 34 00 36 00; Bevel sid'g, clear. 22 50 23 00; No. 1. 22 00 22 50; No. 2. 20 00 20 50; No. 3. 16 00 17 00; Norway, c'l. & No. 1. 23 00 25 00; No. 2. 20 00 22 00; Common. 18 00 19 00.

Albany, N. Y.

ALBANY, N.Y., Nov. 30.—A continued spell of mild weather has been favorable to shipping, and this has worked to the advantage of shippers, who have been enabled to make a big hole in stocks on hand. Not more

than 90,000,000 feet, the lowest for years, will be held over in the yards this winter. We have been bothered this year as in the past for want of boats and as a consequence many orders remain unfilled. Trade is taking a shape of late that operates materially against the business of the middleman. Small dealers now, as well as large, go direct to the mills and buy in carloads to suit their own convenience. This is the case in hardwoods, and especially so with pine, dealers now doing business direct with the mills in the west and in Canada. It has been pointed out that whilst there are advantages in this method of doing business, that with small dealers there are dangers, and they may regret some day that they broke away altogether from the middleman, who in this market at least, has always used them well. Good lumber is decidedly scarce, short in truth of requirements. One by ten inch pine boards are very scarce; in fact, they are almost unobtainable, not even, we are told, in your country.

White Pine. 1 to 2 in, good \$49@50 1 to 2 in, box \$13@16 1 2 4ths 44 45 1 2 to 2 in. 13 17 1 2 selects. 39 40 1 2 in, and up shelving. 20 32 1 2 pickings. 34 35 1 4 " coffin boards 19 23 2 1/2 in, and up, good. 55 58 1 2 " shippers. 16 00@18 2 1/2 " 4ths. 50 53 1 x 10 in, and 12 in, com. 16 00 18 2 1/2 " selects. 45 48 1 x 10 in, and 12 in, sound 18 21 2 1/2 " pickings. 40 43 common. 18 28 1 to 2 in, yard picks. 32 34 1 x 12 in, dressing. 25 28 1 2 " No. 1 cuts. 25 28 " dressing and better 32 33 1 2 " No. 2 cuts. 18 22

Thirteen Foot Stock Boards and Plank. 1 x 10 in, up dressing. \$28@34 1 in, siding, selected. \$38@48 1 x 10 " common. 15 29 1 " " common. 13 18 1 x 12 " " dressing. 29 36 1 1/2 " " selected. 40 45 1 x 12 " " common. 15 22 1 1/2 " " common. 15 20 1 x 10 " up dressing. 28@33 1 1/2 x 10 in, up, dressing. 42c 50c 1 x 10 " culls. 17c 21c 1 1/2 x 10 " culls. 22c 25c

Shingles and Lath. Shingles, shaved pine 6 50 Shingles, cedar mixed 2 75 3 00 2d quality 5 00 Lath, pine. 2 00 2 10 Sawed, extra. 4 40 4 50 Spruce. 2 10 2 10 Sawed, clear butts. 3 10 3 25 Hemlock. 1 80 Cedar, XXX. 4 00 4 20

Buffalo and Tonawanda, N. Y.

TONAWANDA, N. Y., Nov. 30.—The weather has been favorable to the lumber trade, and at a time when there is a good deal to do before winter fairly settles down upon us; this is fortunate. Considerable stock has been coming to hand for yard purposes, and of this not a little of the better stock, which has been scarce here for some time. The time of the year is suggestive of a retrospect of the year's trade now fast coming to a close. It cannot be said that the year has been a particularly bright one for the lumber interests. Labor disturbances have caused a loss to the laboring classes, and naturally had a hurtful influence on the lumber business. The volume of trade at these points will not be up to that of last year. We look forward, however, with good reason for the hope that is in us, for an increased trade in the spring.

White Pine. Uppers, 1, 1 1/2 & 2 in \$45 00 shelving, No. 1 13 in 55 00 and up, 1 in. \$32 00 4 in Dressing, 1 1/2 in. 26 00 Selects, 1 in. 39 00 1 1/2 x 10 & 12. 27 00 1 1/2 to 2 in. 40 00 1 1/2 in. 25 00 2 1/2 and 3 in. 46 00 2 in. 27 50 4 in. 50 00 Mold st'ps 1 to 2 in 32 00 Fine common, 1 in. 33 00 Barn, No. 1. 10 & 12 in 21 00 1 1/2 and 1 3/4 in. 34 00 6 & 8 in. 20 00 2 in. 35 00 No. 2, 10 & 12 in. 17 00 2 1/2 and 3 in. 42 00 6 & 8 in. 16 50 4 in. 45 00 No. 3, 10 & 12 in. 14 00@14 00 Cut'g up, No. 1, 1 in 28 00 6 & 8 in. 14 00 1 1/2 to 2 in. 33 00 Common. 16 00 18 00 No. 2, 1 in. 18 00 1 1/2 & 1 3/4 in. 17 00 19 00 No. 2, 1 1/2 to 2 in. 24 00 2 in. 19 00 No. 3, 1 1/2 to 2 in. 17 00

Box. 1 x 10 & 12 in (No. 3 out) 13 00 1 1/2 in. 13 00 1 x 6 & 8 in (No. 3 out) 12 50 1 1/2 in. 13 50 1 x 13 & wider 14 50 2 in. 14 00 Narrow 12 00@13 00

Shingles. 18-in XXX, clear. 4 00 16-in, \*A extra. 2 60 18-in, XX, 6-in clear 2 75 16-in, clear butts. 2 10

Lath. No. 1 2 25

Oswego, N. Y.

OSWEGO, N. Y., Nov. 30.—Trade has been on the quiet side. Prices are firm. Better grades of white pine continue scarce. Laths have an upward tendency. The work for the season is being rapidly cleaned up.

White Pine. Three uppers, 1 1/2, 1 & 2 inch \$45 00@46 00 Pickings, 1 1/2, 1 & 2 in. 35 00 36 00 No. 1 cutting up, 1 1/2, 1 & 2 in. 31 00 32 00 No. 2 cutting up, 1 1/2, 1 & 2 in. 20 00 22 00 In strips, 4 to 8 wide, selected for moulding strips, 14 to 16 ft. 31 00 33 00

Siding. 1 in siding, cutting up 1 1/2 in selected. 35 00@42 00 p'ks & uppers. 32 00@39 00 1 1/2 in dressing. 19 00 21 00 1 in No. 1 culls. 14 00@15 00 1 1/2 in No. 1 culls. 13 00 14 00 1 in No. 2 culls. 13 00@14 00 1 1/2 in No. 2 culls. 9 50 10 00

12 & 16 ft, mill run 20 00 23 00 10 & 16 ft, No. 1 & 2, barn boards. 17 00 18 00 12 & 16 ft, dressing and better. 26 00 30 00 12 & 16 ft, No. 2 culls. 13 00 14 00

12 & 13 ft, mill run, mill culls out. 19 00 21 00 12 & 13 ft, dressing and better. 25 00 27 00 12 & 14 to 16 barn boards. 16 00 17 00 12 & 13 ft, No. 1 cull. 16 00 17 00 12 & 13 ft, No. 2 cull. 13 00 14 00

14 to 16 ft, mill run mill culls out. 29 00 22 00 14 to 16 ft, dressing and better. 25 00 27 00 14 to 16 ft, No. 1 culls. 16 00 17 00 14 to 16 ft, No. 2 culls. 13 00 14 00 10 to 13 ft, No. 3 culls. 9 50 10 00 1 1-4x10 Inches. Mill run, mill culls out 20 00@23 00 No. 1 culls. 16 00@17 00 Dressing and better. 25 00 30 00 No. 2 culls. 14 00 15 00 1x4 Inches. Mill run, mill culls out 17 00@19 00 No. 1 culls. 13 00@14 00 Dressing and better. 23 00 27 00 No. 2 culls. 11 00 12 00 1x5 Inches. 6 7 or 8, mill run, mill culls out. 19 00@21 00 6, 7 or 8, No. 1 culls. 15 00@16 00 6, 7 or 8, drsg & better 24 00 25 00 6, 7 or 8, No. 2 culls. 13 00 14 00 Shingles. XXX, 18 in pine. 3 80@3 90 XXX, 18 in cedar. 3 50@3 70 Clear butts, pine, 18 in. 2 80 2 90 Clear butt, 18 in cedar. 2 50 2 70 XXX, 16 in pine. 3 00 3 25 XXX, 18 in cedar. 2 00 2 20 Stocks cedars, 5 or 6 in. 4 50 5 00 Lath. No 1, 1 1/2. 2 10 No. 2, 1 1/4. 1 90 No 1, 3/4. 1 60

Saginaw, Mich.

SAGINAW, MICH., Nov. 30.—Little activity prevails in the cargo market, the business in this direction being ended for the season. No more stock will be bought for lake shipment, and we do not hear of any purchasers yet for spring delivery. Prices are stiff, good lumber being short of the demand. Yard trade is good, and the planing mills are doing a fairly active business. Taking the season throughout, the business will show a nice average. The statement is confidently made that there is less unsold lumber on the mill docks in proportion to the total output than one year ago.

Finishing Lumber—Rough.

Uppers, 1, 1 1/2 and 1 3/4 in. \$45 00 Fine common, 1 in. \$31 00 2 in. 46 00 1 1/2 & 1 3/4 in. 26 00 Selects, 1 in. 36 00 2 in. 33 00 1 1/2 & 1 3/4 in. 37 00 C, 7, 8 & 9 in. 34 00 2 in. 39 00 Clear, 1/2 in. 23 00 C, 3/4 in. 17 00 3/4 in. 46 00 7/8 in. 30 00 Select, 1/2 in. 20 00 No. 1, 1/2 in. 12 00 20 00 3/8 in. 39 00 1/2 in. 20 00

Timber, Joist and Scantling.

2x4 to 10x10, 12, 14 and 16 ft \$10 00 20 ft. 12 00 18 ft. 11 00 22 & 24 ft. 13 00 For each additional 2 ft, add 1; 12 in. plank and timber \$1 extra; extra for sizes above 12 in.

Shingles.

XXX 18 in. Climax. 3 50 18 in X (cull). 50 XXX Saginaw. 3 40 XXX shorts. 2 00 XX Climax. 2 00 XX. 1 25 18 in 4 in c. b. 2 00 Sol.

Lath.

Lath, No. 1 white pine. 2 00 Lath No. 2 W. pine Norway 1 50

Boston, Mass.

BOSTON, MASS., Nov. 30.—Quietness in lumber reigns supreme at the Hub. No great volume of business has been done during the month, and we are likely to have a quiet winter. Spruce is keeping an emphatic upper lip, seldom, if ever, has the position been more firm. It is only fair to say that the chief reason for this is its scarcity, rather than any particular demand. Prices on hard pine are low and have ruled so all summer.

Western Pine—by car load.

Uppers, 1 in. \$48 00@50 00 Fine com. 3 & 4 in. 42 00@46 00 1 1/2, 1 3/4 & 2 in. 48 00 50 00 No. 2, 1 in. Fine com. 28 00 30 00 3 & 4 in. 55 00 60 00 1 1/2, 1 3/4 & 2 in. 29 00 31 00 Selects, 1 in. 42 00 43 00 No. 1 strips, 4 to 6 in. 40 00 43 00 1 1/2, 1 3/4 & 2 in. 43 00 45 00 No. 2. 35 00 37 00 3 & 4 in. 45 00 50 00 No. 3. 24 00 26 00 Moulding boards, 7 to 11 inch clear. 36 00 38 00 Coffin boards. 19 00 22 00 60 per cent clear. 34 00 36 00 Common all widths. 22 00 26 00 Fine common 1 inch. 36 00 38 00 Shipping culls 1 in. 15 00 15 50 1 1/2, 1 3/4 & 2 in. 38 00 40 00 do 1 1/2 in. 15 50 16 50

Eastern Pine—Cargo or Car Load.

Nos. 1, 2 & 3. 40 00@43 00 Clapboards, 4 ft., sap clear. 40 00 45 00 5. 28 00 30 00 clear. 33 00 35 00 Ship'g bds & coarse. 16 00 16 50 Heart extra. 50 00 55 00 Refuse. 12 00 13 50 Heart clear. 45 00 50 00 West'r pine clapbds. 4 ft. sap extra. 45 00 50 00 Bevel siding 6 in, clear 23 00 24 00

Spruce—by Cargo.

Scantling and plank, random cargoes. 14 00@15 00 Coarse, rough. 12 00 14 00 Yard orders, ordinary sizes. 15 00 16 00 Hemlock bds., rough 12 00 13 00 Yard orders, extra sizes. 16 00 18 00 Clapbds., extra, 4 ft. 34 00 36 00 Clear floor boards. 19 00 20 00 Clear, 4 ft. 30 00 32 00 No. 2. 16 00 17 00 Second clear. 25 00 No. 1. 10 00 14 00

Lath.

Spruce by cargo. 2 10@2 20

Shingles.

Spruce. 1 25@1 50 Cedar, sawed, extra. 3 35 3 50 Pine, 18 in, extra. 4 00 4 25 Clear. 3 00 Pine, No. 1. 3 00 3 15 Extra, No. 1. 2 50 Cypress, No. 1, 18 in. 5 00

—J. L. Hughes, of Brandon, Man., is in receipt of two large barges of lumber from his mills on Rainy River. The expectation is that the entire summer's cut will be received before the close of navigation.

SAW LOG SLEIGHS FOR SALE—VERY CHEAP.

FIFTY sets one team saw log sleighs, new Ottawa pattern (steel shod), made of the best material throughout, good as new. MOSSOM BOYD & CO., Bobcaygeon, Ont.



A REPLY TO AMERICAN NONSENSE ON THE DUTY QUESTION.

Editor Canada Lumberman:—What is the matter with the editor of the Northwest Lumberman, does he sleep o' nights? or is he physically unstrung by insomnia resulting from the "bogey" he has conjured up regarding the disastrous effects on American lumbermen's interests by the admission of Canadian lumber into the United States at the current rate of duty? The frantic inconsistency in some of the pleas put forth both in the opening letter by Mr. Huyett and followed by equally absurd propositions in letters of commendation that appear in the issue of the paper Nov. 28th, are to say the least refreshing. It would seem that we Canadians are terrible people. We actually control the Congress of the United States. We compelled the legislation which resulted in the decrease of the duty from \$2 to \$1. Was ever any statement so absurd? What are the facts? Under the McKinley act it was decreed that the duty on pine lumber should be reduced to \$1, but that from any country imposing an export duty on logs exported into the United States, an import duty should be collected on lumber equal to the export duty so collected. Against what country was that directed? any other than Canada? did that show it was Canadian influence which produced the lowering of the duty or did it clearly show that Canada must be brought to time and be made to abolish the export duty then imposed on logs? The complaint is also made that Canada lumber demoralizes prices on hemlock and coarser grades of pine etc., "and that its admission benefits no one but the Canadian." How does it demoralize the market, by selling at lower prices? If so, does it not benefit some one, does it not benefit the American consumer, and who gets the benefit of the lower duty? An appeal is made to all employees of lumber concerns to unite in recommending some measure that will result in the exclusion of Canadian lumber. Why should they, will they benefit, will their salaries or wages be greater, were they larger when Canadian lumber was subject to a \$2 impost, would they be raised if the former duty were restored? I think not. The idea of the greatest protectionist country on earth finding fault with another people because they pursue the same policy is, to say the least, cool. Because Canada wants to have Canadian logs manufactured into lumber in Canadian territory, it is termed a rank injustice to American interests, when the whole spirit of American industrial legislation is that American interests shall be fostered and developed on American soil. Fault is found with Ontario Province because she now will not sell her own private domain unless the product be manufactured within her borders; is there anything unfair in that; is it not publicly made known as one of the conditions of purchase that such shall be done? Where is the trickery? Americans, or for the matter of that, Canadians, who don't wish to purchase under such conditions, are not compelled to. As an economic question it of course narrows itself down to whether the consumer pays the duty or not, and parties in the United States, judging by the late elections are, to say the least, evenly divided on that matter, but to attribute the lowering of the duty to the sinister influence or even the active work of Canadians is ridiculous to those who daily see the hostility with which anything appertaining to Canadian interests is met in either the Congress of the United States or the local State Legislature.

Let the fault, if any, be laid at the door of American legislators, but don't blame Canadians for what they have not done.

The Northwest Lumberman should be the representative of all the trade, not of a faction. Perhaps at a later date I may return to the subject.

M.

TORONTO, Nov. 30, 1891.



## MICHIGAN LETTER.

Decline of Water Shipments—Trade Prospective and Retrospective—Decadence of Michigan Forests.

A Dam at Niagara Falls.

[Regular correspondence CANADA LUMBERMAN.]

THE shipments of lumber by water from Saginaw river ports during the season have been the smallest for many years, and are in the line of a gradual decline, which must ultimately have a serious effect on the water-carrying trade of the State. The following figures exhibit the shipments for the season to Nov. 1 from the entire Saginaw river for five years and illustrate the fact just stated.

	Lumber.	Shingles.	Lath.
1887.....	486,081,627	74,497,000	25,128,000
1888.....	436,326,000	75,802,000	29,474,000
1889.....	376,880,000	87,705,000	18,554,000
1890.....	382,162,000	70,547,000	11,397,000
1891.....	365,228,000	72,327,000	13,099,000

It is to be remembered, in this connection, that while the shipments by water are steadily decreasing, the railroads are each year capturing a larger lumber business.

The season's trade is well over. Lumbermen are viewing the work now both retrospectively and prospectively.

Freight rates to Buffalo and Tonawanda have been advanced, and I hear of two firms who have sent instructions to forward no more of their lumber until next spring.

Some failures, as you know, have occurred this year, and Michigan lumbermen have not altogether escaped their effects. The Hagard failure struck a number of Bay City men, and the P. A. Scribner troubles of the present month have roped in quite a number from Bay City. This firm did business at Tonawanda and the Michigan men, who suffer are: Pitts & Grange, \$17,000; Eddy Bros., \$5,500; Eddy, Avery & Eddy, \$2,800; S. G. M. Gates, \$1,600; Thomas Madden, \$4,500.

## LUMBER CONDITIONS.

Dealers generally, express themselves as satisfied with the trade that has been done, despite occasional set-backs, some of which I have hinted at in this and previous letters. A prominent manufacturer here, who has been in the business in Muskegon for twenty-five years is authority for the statement that with the exception of one or two "boom" years the season of 1890-1891, has been the best, all things considered, within his memory. He bases this statement upon the fact that from the very beginning, starting with lumbering operations last winter, every condition has been favorable to the logging, driving and manufacturing of pine with a minimum expense and without losses or casualties worthy of note.

The question of the decadence of the lumber industry in a State possessed of the lumber importance of Michigan is always a leading question and gives rise to much in the way of conjecture and often little that has no other quality to recommend it. In 1867, a writer, who was supposed to have good knowledge of the question discussed, estimated the total standing pine in the Saginaw and Au Sable districts at 5,241,600,000 feet, which, at 300,000,000 feet yearly cut would be exhausted in 17 years. Well, the seventeen years are a good many years over run, and still a rather lively cut goes on. Not in any one year since that date has the production fallen below 451,000,000 in any season. At the same time there are individual parts of the State where the timber is becoming decidedly scarce. A lumberman who recently returned from a trip to Muskegon River, where he has been looking over the lumbering prospects for the coming season, is reported as saying: "that where once the woods resounded with the crash of the axe there is now a dreary waste of barren plains, swamps and straggling trees. The camps on the Muskegon River to be operated this winter, he says can be counted upon the fingers of the two hands. In the Higgins and Houghton Lake district, Matthew Wilson is about the only one who has any standing pine and but a handful, perhaps not to exceed 15,000,000 feet, which he will throw into the lake this winter. The other belts southward, along the stream and its branches, are being operated, the most of them by logging railroads and it is seldom that the primitive

methods of Michigan lumbering are seen. The present will wind up all but about half a dozen lumbering tracts tributary to this city and next season the Booming Company do not anticipate, nor have they counted on receiving more than 250,000,000 feet for the drive, and this, President Hill thinks may possibly be reduced about 50,000,000 feet. A quantity of logs will be brought to the city direct by rail and in some instances rafts will be made on Lake Michigan."

To remedy in part, at least, the trouble caused this season in Saginaw river and lake ports, the suggestion has been made to build a dam at Niagara Falls. Capt. Marshall, the government engineer in Chicago, however, says the only practicable way to get more water in the lake channels is to dig deeper. Should dams be built he says that in two or three years the water in the great lakes will be so high that people will be clamoring against that as they are now against low water.

PICA.

SAGINAW, MICH., Nov. 25, 1891.

## OTTAWA LETTER.

Closed of the Season—A Short Cut—Large Increase in Bush work—5,000 Men in the Woods—A Lumberman for the Cabinet—Lumbermen in Court—Where the Profits come in—Timber Limit Purchases—Piece Stuff.

[Regular correspondence CANADA LUMBERMAN.]

SO far as mill operations are concerned we have reached the end of the season. If every saw in every mill hereabouts has not stopped buzzing each is near enough the last kick to exhibit little life in the effort. The season in some respects at least has not been over satisfactory. I expect in a future letter to give you figures telling with proper exactness the outcome of the season's trade. I cannot do this to-day, but with what information is in my possession there is no risk in saying that the cut will be much behind last year. J. R. Booth has said this of the cut of his mill, and Pierce & Co. have only cut nine million feet against fifty million last year, their mill at the Chaudiere having been closed down throughout the season.

This short cut, however, is not an unmixed evil. It has left our piling grounds well cleaned out of nearly every kind of lumber. Prices have as a consequence stiffened, and the winter in the woods will be one of the busiest lumbermen have experienced for years.

Five thousand men will spend the winter in the bush this year—I am speaking only of operations of Ottawa lumbermen—as compared with three thousand last year. Road cutters are getting \$12 to \$16 a month (and their keep of course), general hands \$16 to \$20, log cutters \$20 to \$22, scorers \$26, liners \$30, hewers \$35 to \$40, cooks \$30 to 35. There is an increase of about \$4.00 a month all round. The estimates of the men employed in most of the shanties this winter are given as follows:

Bronson's & Westman, 990; Buell, Orr & Hurdman, 600; Hawkesbury Lumber Co., 400; McLaren & Edwards, 300; Ross Bros., 400; Canada Lumber Co., 200; Edward Moore, (square timber) 100; Emery Lumber Co., 300; Rochester Bros., 100; R. H. Klock's, 150; Booth's 200; Perley & Pattee's, 500. Locally this means a good deal for Ottawa and Hull. Taking an estimate of 5,000 men in the woods, with an average of \$20 a month will be an expenditure for wages alone, by the lumbermen of about \$100,000 per month, or \$500,000 for the season. The increase in pay over last year will be between \$80,000 and \$100,000.

HON. PETER WHITE FOR CABINET MINISTER.

The question of lumber representation in the Cabinet is being considered by prominent lumbermen in this section. A few days ago a deputation consisting of J. R. Booth, G. H. Perley, Hiram Robinson and Berkley Powell had an interview with Premier Abbott with this object in view, strongly urging the claims of Hon. Peter White, now Speaker of the House of Commons, to a position in the Cabinet. Mr. White was for years engaged in lumbering and as a lumberman likely knows as much of lumber affairs as the next man. He has been a member of Parliament for some years, representing the north riding of the County of Renfrew. Neither friend or foe will dispute his ability to hold a seat in the

Dominion Cabinet, and altogether aside from the present movement his name has frequently been mentioned when the question of Cabinet making has been to the fore, as it has very much been, since the death of Sir John A. Macdonald. Whether he should have a place there as the representative of any particular trade interests is a question on which people will divide opinions. Abundance of precedents exist in Canadian Parliamentary practice to support the custom, for class interests hold powerful sway in our politics. Goldwin Smith tells us that this is the rule of merit in Cabinet making, one man being chosen because he is prominent in Orange circles, another for the reason that he is a good Roman Catholic, and a third to represent the prohibition movement, and so on. Perhaps so, but I shall not tread further on the dangerous field of politics.

## TWO IMPORTANT LUMBER SUITS.

The suit in connection with the David Moore estate, to which you made some reference in your news columns last month has since been settled, Edward Moore agreeing to pay each of the other heirs, six in number, \$7,500, which offer was accepted. When David Moore, the father died, he was one of the wealthiest lumbermen in the Ottawa Valley, his estate being valued at \$700,000. His eldest son, Edward Moore, was left in charge of the estate. He managed it with business ability and success, having since paid out \$250,000 to the other heirs. Some complications arising as to the administration of the Quebec portion of the estate as well as a question about a large Ontario limit which had been left separately to Edward Moore by his father, the other heirs began the suit which has just been amicably settled. With regard to the disputed limit, the contention of the other heirs was that, although David Moore gave it to his eldest son, which they admitted, they held that this was under a misapprehension. Edward Moore, while repudiating this, nevertheless was prepared to make some concessions with them in view of the appreciation in value of the limit. The facts show where the profit in lumbering comes in. David Moore bought the limit originally for \$4,000. Edward Moore during his father's lifetime made \$46,000 out of it, and after his father's death \$30,000 more and finally sold it for \$46,000; total, \$126,000.

The action brought by G. B. Pattee, G. H. Perley and C. Berkley Powell, for damages against John McKay for obstructing and shutting off the waters of the Amable du Fond river has been dismissed with costs. The plaintiffs have an extensive timber limit on Long Lake and by means of the Amable du Fond, thence by the Mattawa, thence by the Ottawa, they convey their logs to their mills. They claim that in August last, while they had 25,000 logs in transit, the defendant made a dam on the Amable du Fond, which injured the river as a stream for floating logs by reducing its current. Plaintiffs claim \$4,000 damages, and a declaration that the said river cannot be so injured and that Mr. McKay shall have no right to dam it. The decision rendered, confirms McKay in his right to dam the Eau Claire river, not saying what the consequences may be.

## TIMBER LIMIT SALE.

The timber limits of Messrs. Dougherty & Rochester and R. Gorman were sold by public auction during the month, creating considerable activity among lumbermen. Parcel No. 1.—Kippewa Berth, No. 21, on White Pine river was the first offered. Bidding started at \$10,000 and went as high as \$31,400, when it was knocked down to J. C. Edwards, M.P., of Rockland. Parcel No. 2—Berth A and B on river Coulonge, area 100 square miles, was withdrawn as was also the supplies and plant for the shanty, only \$18,000 being offered. The limits of Messrs. Dougherty & Rochester sold en bloc. They comprise licenses 280, 281, 283, and 284 on the Mattawa, with 21 miles frontage. Captain Murphy bidding \$57,000 at which price it was sold, the purchasers being Messrs. Thomas and William Murray, of Pembroke. A few days later these gentlemen sold the limits again to the Rathbun Company of Deseronto, at an advance on the price paid. It is stated that the Rathbuns will erect a mill between Klock's and Mattawa and thoroughly work the limits.

PIECE STUFF.

Napoleon Fateaux, who won for himself the sobriquet of "the Bonaparte of the Chaudiere" during the late strike still continues to inspect the town, as none of the mill owners will hire him. This is rough on Napoleon, but no more than he deserves.

A local paper makes the statement that the mill owners who were responsible for calling out the troops during the recent riots have decided to settle the little bill on their own account.

A report of Chief Young shows that the fire losses in the city since 1881 total up nearly half a million of dollars. Details of the nature of the fires are not given, but, there is no doubt that a considerable percentage of them is represented in the lumber trades.

Forwarders have been experiencing some difficulty in getting American boats to touch at this port, in consequence of the recent strike. Dealers have orders for the States but are troubled because of this want of shipping accommodation.

What is known as the little mill of Messrs. Buell, Orr, & Hurdman, situated close to the falls on the Hull side will be almost entirely rebuilt and made about as large as any mill in the locality. Three new saws and two patent gates are among the new machinery to be placed in it.

An experiment in cutting logs was made at J. R. Booth's mill at the Chaudiere on 7th inst., between the gangs of two patent gates, one of which was purchased by the firm this year. The men worked half a day and cut together 1,800 logs, which surpasses all previous records for that length of time. The men on the new gate cut five more than those on the old one. In addition to the two gates there were nine bandsaws at work the same afternoon, so that the cut all told must have been a very large one.

Mr. Robert Hurdman is on a trip to his lumber shanties.

At a meeting of the Trades and Labor Council held during the month, the following report was presented touching the late strike. It gives the men's view of the case:—

The struggle lasted just four weeks and three days and resulted in very material gain for the men engaged. There were about 2,200 men out and when the strike was declared off on the 16th by the committee the following was shown to be the result:—

Firm.	Previous hours.	Present hours.	Previous wages.	Present wages.
Mason . . .	11	10	6.50 to 7.00	6.50 to 7.50
Bronson . .	11½	11¼	6.50 to 7.50	7.00 to 8.00
Perley . . .	11¾	11¼	6.50 to 7.50	7.00 to 8.00
Booth . . .	11¾	11¼	6.50 to 7.50	7.00 to 8.00
Hurdman . .	11¾	10	6.50 to 7.50	6.50 to 7.50
Pierce . . .	11	10	6.50 to 7.50	7.00 to 7.50
Shepherd . .	11	10	6.50 to 7.50	7.00 to 7.50
Ex. L. Co. .	11	10	7.00 to 7.50	7.00 to 7.50

OTTAWA, CAN., Nov. 25th, 1891.

BRITISH COLUMBIA LETTER.

The "Devil Club"—B. C. Fir and Cedar in Toronto—Shingle Cutting all Winter—A New Lumber Company.

[Regular Correspondence CANADA LUMBERMAN.]

YOUR article in the October LUMBERMAN of "Trees that Sting," reminds any one acquainted with the woods in British Columbia of the "Devil Club." The effects of the two are alike and are both to be avoided, if possible.

I have just learned that quantities of B.C. fir and cedar have been used in the new Confederation Life

building, going up in your city. The opinion of the contractors re these woods would be valuable to a large number of your subscribers.

Mr. MacCaulay, of the Chemainus Lumber Co., has gone to Chili, and Mr. John Wilson, of the Brunette Saw Mill Co., has gone to Australia, both in the interests of their respective firms.

The Revelstoke Lumber Co. will cut shingles all winter and get out six million feet of lumber for 1892 cut. They will soon close down the main mill for the winter.

Elmer Ward's new side-wheel boat has made its trial trip, to the satisfaction of all interested; it will be principally used on the Fraser river.

The new mill at Barnet, Burrard Inlet, will be ready to start sawing early next spring. Nearly all the machinery is in place. It is a very complete mill of 330 ft. x 50 ft., two stories. The iron burner 120 ft. high, is provided with a water jacket extending 30 ft. up its base. A siding is built. The company have very good water works for fire protection.

The Smelter Co. at Pilot Bay, Kootenay, are building a wharf 700 feet long; 500,000 feet of lumber will be used exclusive of covering.

The Pacific Coast Lumber Company of New Westminster is seeking incorporation. The managing directors of the company, Messrs. Scott, McCormick, Allen & Port, have decided to fit up their mill with the newest and most improved machinery for lumbering, and their order, which is a very heavy one, is now being placed on the cars in the east and is expected to arrive here in a week or two. The mill is situated on the end of Lulu Island just west of Messrs. McGillivray & Co.'s shops, and was formerly owned by the North Pacific Lumber Company, now extinct. The plant at present in the mill is sufficient to get out lumber for the more extended premises which the Pacific Coast Company intend to begin the erection of at once. As soon as the new machinery arrives and the necessary powers are obtained the mill will be started and run at full capacity. All the directors are thoroughly practical men with large experience in the lumber business.

H. G. R.

NEW WESTMINSTER, B. C., Nov. 18, 1891.

TRADE NOTES.

To get the best is the policy of a shrewd business man always. It is an especially sensible rule to follow in the purchase of an article connected with machinery. The poor thing is sure to go to pieces at the time one is busiest, and will give trouble when trouble is least wanted. The record of the Friction Grip Pulleys, manufactured by the Waterous Engine Works Co., of Brantford, Ont. appears to be one of unqualified satisfaction in all quarters. Seldom it is that a manufacturer can give to the world such a list of first class references of an article of machinery as is published in the LUMBERMAN for this month, of the Grip Pulley and Couplings of this company. A rather unusual, but very practical test of the strength of the Grip Pulley, was shown in the case of an accident a few days ago on the Sandwich, Amherstburg and Windsor Electric Railway. Something gave way and everything connected with the make-up of the train felt the force of the accident. The dynamo did not even escape, but an examination afterwards showed that the Grip pulley remained undisturbed and its natural strength in no way abated by the strain that had told on all the other parts. The Waterous Co. will be pleased to furnish particulars of these celebrated pulleys.

CHIPS AND BARK.

Makers of certain lines of wood goods and sawmill men are not careful enough in their selection and grading—and which is often too true.

A handsome maple would be considered the last of all trees to need to blush for anything, but it is generally the first to turn red.

There is just as much difference between pro and con example as there is between a horn which blows a tune and one which blows a tune.

A "crank" is now defined as a brainy yet unpractical man who has spent his life turning fortunes wheel for other men to draw prices therefrom.

Nothing but a stump now remains of the weeping willow which for so many years marked Napoleon's burial place at St. Helena.

City life is a severe trial. One man is struck with dry rot; another develops season cracks; another shrinks and swells with every circumstance. Few men stand the drying out of the natural sap of their greenness in the artificial heat of city life.

A Georgia editor, who is also a dealer in timber and pastor of the village church, was recently called upon to perform the marriage ceremony. He was in a great hurry—in fact, the couple surprised him in the middle of a heavy editorial on the tariff. "Time is money," said he, without looking up from his work. "Do you want her?" The man said, "Yes." "And do you want him?" The girl stammered an affirmative. "Man and wife!" cried the editor. "One dollar. Brink me a load of wood for it—one-third pine, balance oak."

BITS OF LUMBER.

The woods chiefly used by the Greeks and Romans were the cedar, ash, oak, yew, lotus, citron and ebony.

A Saginaw lumber firm exhibits a white pine board 16 feet long by 40½ inches wide, containing one knot the size of a nickel.

The smallest tree that grows in Great Britain may be seen on the very top of Ben Lomond. It is the dwarf willow, which at maturity, reaches a height of only two inches.

On the farm of Mr. E. Boughner, lot 6, con. 13, Windham, Norfolk Co., there is an apple tree having a girth of 9 ft. 1 in. One of the branches measures, 6 ft. 6 in. in circumference. The tree is 60 years old and is still flourishing.

Examinations of mounds in Jersler parish, in Northern Jutland, by archaeologists, have led to the discovery of oak coffins dating from the Early Bronze Age, about 1,000 B.C. Hitherto such oak coffins have only been found in Southern Jutland.

The systematic replanting of the Malagan forests is urged in a Kew bulletin, or gutta percha will disappear. Fifty years ago gutta percha was unknown in Europe. Now the annual consumption amounts to 4,000,000 pounds, with a constantly increasing demand, and the trees where it is obtained in the East Indies cover a very limited area and are being rapidly used up.

Dwarf trees, only two feet high, exact productions in miniature of sycamore, oak, cedar and apple trees, have for 200 or 300 years been raised by the Japanese. The mode of producing them is a well guarded secret, but some French gardeners have, within the past five years, almost equalled the Japanese in the production of these dwarf trees.

It has been generally asserted by the weather-wise that we are to have a cold winter with plenty of snow, but old Indians, who are accredited with a fair knowledge of weather indications gathered from nature, assert that the cold and snow will come early and go quick, and will be followed by an open and mild winter. Some lumbermen, much as they dislike the prediction, are prepared to gamble on the red man as a weather prognosticator against his white brother.

**OAK TANNED BELTING**

TORONTO  
20 FRONT STREET  
TELEPHONE 475

**THE J.C. Mc LAREN BELTING CO**

MONTREAL

**A. M. DODGE & CO.**

MANUFACTURERS of and Wholesale dealers in all kinds of Lumber, Lath and Shingles. Tonawanda, N. Y.

**COWPER & GREGORY.**

RECEIVERS and Forwarders of Lumber, Lath, Shingles, &c. Unexcelled facilities for shipping by canal or rail. Tonawanda, N. Y.

**CHEESMAN DODGE**

TIMBER and Lumber Merchants. Ship and Boat Stock, Railroad Ties, &c. Office, 10 West Street, Buffalo, N. Y.

**EMMET FLEMING**

INSPECTOR and Commission dealer in Lumber. Office, 251 Louisiana Street, Buffalo, N. Y.

**LAYCOCK LUMBER CO.**

MANUFACTURERS of Pine, Hemlock and Oak Timber up to 55 feet in length. Saw Mills: Acklev, Pa., Black Rock, N. Y., Gravenhurst, Ont. Office, corner Main and Seneca Sts. Buffalo, N. Y.

**J. & T. CHARLTON**

WHOLESALE dealers in Masts and Spars, Canada Round Pine, &c. Tonawanda, N. Y.

**WILLARD W. BROWN.**

202 Main Street, Buffalo, handles all kinds of Hard Woods.

**A. P. & W. E. KELLEY CO.**

WHOLESALE Lumber dealers. Yards at Tonawanda and Chicago. Correspondence invited.

**C. P. HAZARD.**

WHOLESALE dealer in Lumber, Shingles, Lath and Fence Posts. Correspondence invited from the Canadian trade. No 92 River Street, Buffalo, N. Y.

**L. A. KELSEY LUMBER CO., (Ltd.)**

MANUFACTURERS and dealers in Hardwood Lumber of all kinds. Describe stock and write for prices. Office Tonawanda, N. Y.

**BOVEE & HOWDEN**

MANUFACTURERS and Wholesale dealers in Hard and Soft Wood Lumber. Holders of Canadian stocks are invited to write for quotations. Offices at Tonawanda and Le Roy, N. Y.

**THE TONAWANDA LUMBER CO.**

MILLS at East Tawas, Mich.; office 106 Main Street, opposite N. Y. C. and H. R. R. Station, North Tonawanda, N. Y.



**LUMBER**

**TRUCK \* WHEELS.**



**The Montreal \***

**\* Car Wheel Co.**

MANUFACTURERS OF

**CHARCOAL IRON CHILLED**

**RAILROAD WHEELS**

Offices: New York Life Insurance Building, Montreal.

Works: Lachine, Quebec.



WE make a Specialty of Wheels suitable for the requirements of Lumbermen and Street Car Service, and can supply them Bored, Finished and Balanced.

CORRESPONDENCE SOLICITED

**J. J. TURNER,**

**Sail, Tent and Awning Maker,**

251 GEORGE AND 154 KING STREETS, PETERBOROUGH.

Canoe, Yacht and Boat Sails made to order. Perfect Fits guaranteed. Every description of Lumbermen's Supplies and Waterproof Clothing.

**THE MONARCH BOILER AND HERCULES ENGINE.**

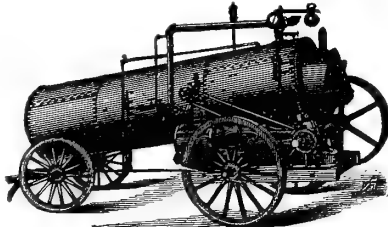

Portable from 6 to 70 horse power. Surpass portable steam power heretofore produced for strength, durability, compactness, and the ease with which they can be moved. The 70 horse power can be taken over the roughest roads, or into the forest, and set up as easily and quickly as an ordinary 20 horse power portable engine, and as firm as a brick-set stationary engine. Engines and boilers of every size and description. Rotary Saw Mills, Shingle and Lath machines, Law Grinders, Planers, etc. Mill machinery and supplies of every description. Every boiler insured against explosion by the Boiler Insurance & Inspection Co. of Canada. Write for circulars.

A. ROBB & SONS, Amherst Foundry and Amherst, N.S. Machine works. ESTABLISHED OVER 40 YEARS.

**PORTER, ROBERTSON & CO.**

STOCKS  
STRIPS  
SIDINGS  
BILLSTUFF

WHOLESALE

**LUMBER**

DEALERS

HARDWOODS  
HEMLOCK  
SHINGLES  
LATH, ETC.

Millichamp's Buildings,

35 \* Adelaide \* Street \* East,  
TORONTO.

YARD: NORTHERN DOCK, FOOT OF BATHURST STREET.

GEO. HASTINGS.

JOHN GRAY.

H. HANCOCK.

**GEO. HASTINGS & CO.**

**Lumber Merchants**

TRUST BUILDING CHAMBERS,  
Cor. Yonge and Colborne Streets.

TORONTO.

All Kinds of Pine and Hardwood Lumber.

BILL STUFF CUT TO ORDER A SPECIALTY.

**NAPANEE CEMENT WORKS**

— MANUFACTURERS OF —

**Hydraulic Cement**

PARTICULARLY adapted for Dams, Smoke Stacks, Foundations, Culverts, Cisterns, Cellars, etc.

ENDORSED BY LEADING RAILWAYS AND CONTRACTORS.

**ROACH \* LIME,**

For Building, Plastering, Gas Purifying, Paper Making, &c.

**THE RATHBUN COMP'Y,  
DESERONTO, ONT.,**

MANUFACTURERS OF

**\* TERRA \* COTTA \* FIRE-PROOFING \***

For Use in Old and New Buildings.

Endorsed by Leading Architects. Absolutely Fire-proof. About as Cheap as Wood or Brick. Weight One-Third that of Brick. Does not Crack on application of Heat or Water. Deadens Noise. Gives Warmth in Winter; Coolness in Summer.

HERBERT G. ROSS.

Box 278.

REGINALD C. BLAKER.

**H. G. ROSS & CO.**

Real Estate, Fire and Life Insurance, Shipping and General Commission Agents.

Timber Limits and Farming Lands a Specialty.

A.B.C. Code, Cable address, "Ross."

**NEW WESTMINSTER,**

**B. C.**

CORRESPONDENCE SOLICITED.

**Galt \* Machine \* Knife \* Works.**



**MACHINE KNIVES**

OF EVERY DESCRIPTION FOR

Planing, Moulding & Stave Cutting.

SEND FOR PRICE LIST

PETER HAY, - - - GALT, ONT



# H. W. PETRIE, Machinist and General Machine Dealer

ESTABLISHED 1876.

Main Office, Yard, Storehouse and Shipping Depot, Opp. Union Passenger Station, Toronto, Canada.

\* 141-145 FRONT ST., WEST. \*

Send for  
One of My  
New  
Catalogues  
FREE.

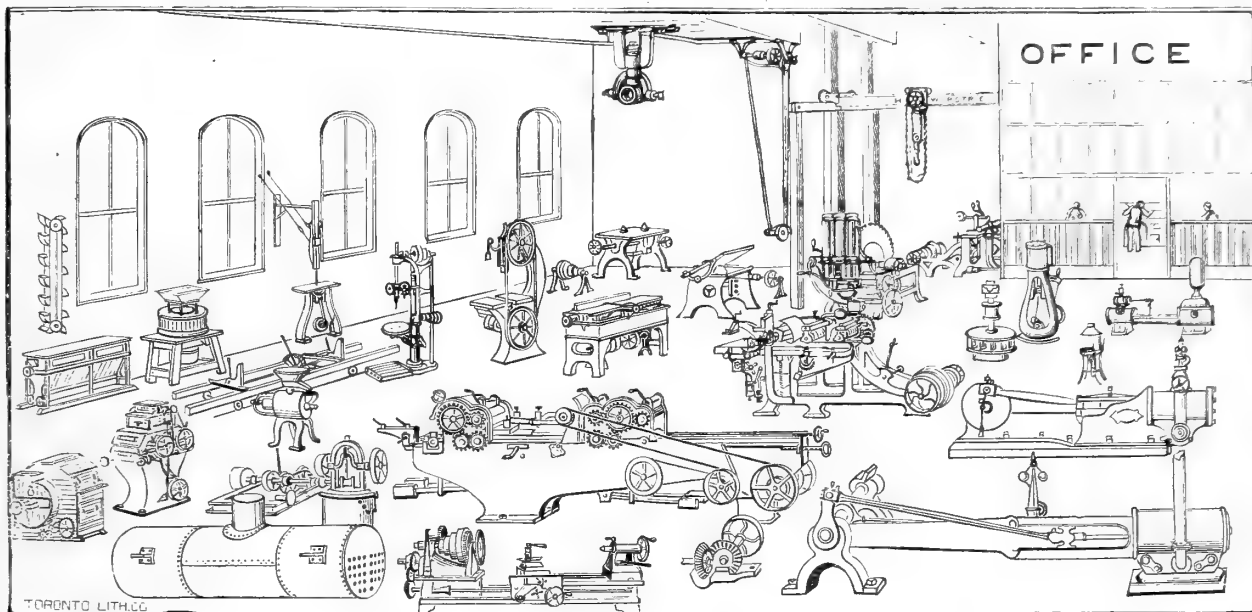

New  
66 Page  
Descriptive  
Catalogue  
Just Out.

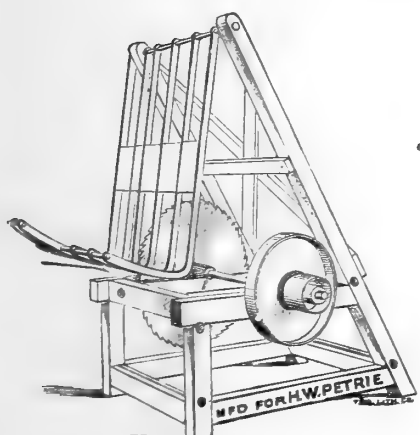

Wood and Shingle Bolt Saw.

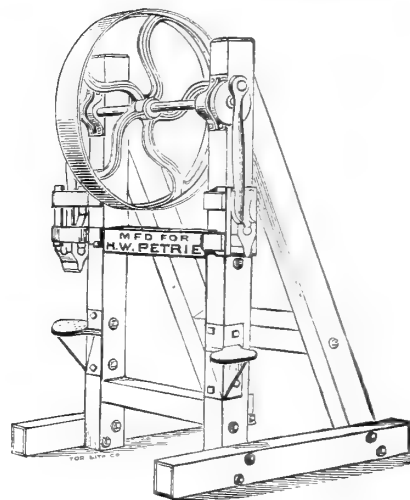

The Champion Wood Splitter.

## WOOD YARD MACHINERY

-:- A Specialty. -:-

See New Catalogue No. 16.

The Improved Little Giant Planer, Masher and Moulder.

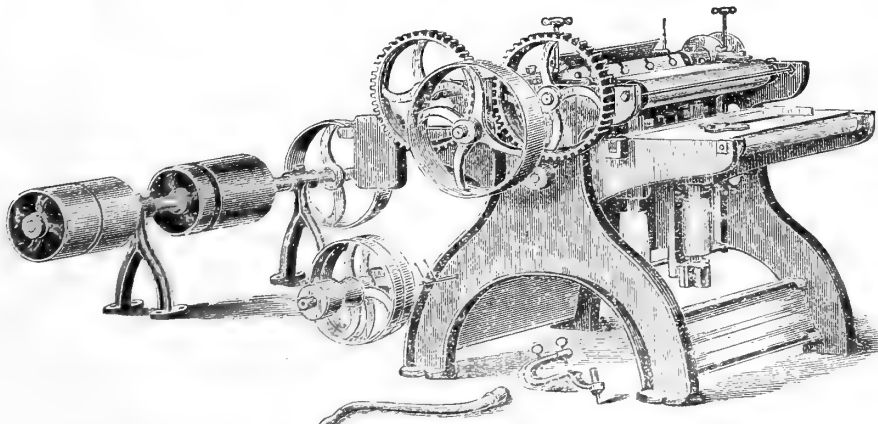

**25,000**  
**CATALOGUES**  
NOW READY  
FOR DISTRIBUTION

CATALOGUE NO. 16  
GIVES FULL  
**DESCRIPTION**  
OF ALL  
OUR MACHINERY

Planing and Saw Mill Machinery of all Kinds.

**CIRCULAR**



**SAWS.**

**WANTED AND FOR SALE.**

Advertisements will be inserted in this department at the rate of 15 cents per line each insertion. When four or more consecutive insertions are ordered a discount of 25 per cent. will be allowed. This notice shows the width of the line, and is set in Nonpareil type. Advertisements must be received not later than the 27th of each month to insure insertion in the following issue.

**TENDERS WANTED.**

OWNING health owner, a new and complete shingle mill equipped with latest improved machinery, 3 1/2 miles from N. & N. W. R.R. must be sold. Full room and shafting for second machine, water power sufficient to run several, timber unlimited, and convenient to operate mill winter and summer. With mill site, 5 acres of land, large boarding house, stable, also horses, sleighs, waggon, and plant for efficient equipment of mill and camp. There is big money in business for man with small capital. Must be disposed of at once. Terms liberal. Tenders will be received by the undersigned, from whom all particulars can be learned. Address, R. H. MYERS, Bracebridge, Ont., Vendor's Agent.

**WANTED FOR CASH.**

**Half a Million Feet of Ash.**

**M**OSTLY 1 inch, some 1 1/4 and 1 1/2 inch Canada Ash, strictly first and seconds; must be of uniform color, also common and 1 inch Elm, I and II. State particulars as to stock on hand dryness and lowest prices F. O. B. Montreal, Que. Address all particulars to

P. O. Box 2144,  
NEW YORK,  
N. Y.

**WANTED—TO BUY.**

**G**OOD Canadian Timber Limits and Georgian Bay saw logs. Address, BEN BIRDSALL, Whitney Building, Detroit, Mich.

**H**ARDWOOD lumber, bought, sold or received on consignment, TUCKER DAVID, lumber commission merchant, 202 Eleventh Ave., N.Y.

**SAW AND SHINGLE MILL**

**F**OR SALE—on the Manitoulin, near Little Current. A bargain. Address, W. L. H., CANADA LUMBERMAN.

**WANTED AT ONCE FOR CASH.**

**E**LM dimension stock, cut to exact sizes for furniture manufacture. Give prices and full particulars to P. O. Box 2144, New York.

**PARTNER WANTED.**

**T**O join advertiser in manufacturing mill machinery and patented specialties. Must have \$3,000 to \$5,000 cash. Experience not necessary if capable of keeping books and attending to office work. Address, "D" care CANADA LUMBERMAN.

**STEEL RAILS, ETC.**

**S**EVERAL thousand feet T rails 12 and 20 lbs. to the yard. A large quantity of flat strap rail for tramways, 20 pair wheels and axles, all in good second hand condition, very cheap.

JOHN J. GARTSHORE,  
49 Front Street, West,  
Toronto.

**WILLIAM FOSTER**

**Lumber & Commission Merchant**  
Receiver and forwarder of  
**LUMBER, LATH & SHINGLES**  
Correspondence Solicited.  
**OWEN SOUND, ONT**

**WANTED SAW MILLS**

**IN - LITTLE - BELT**

**ROCKY MOUNTAINS**

ALONG LINE OF  
**Great Northern Railway**

For particulars write  
**J. M. HUCKINS,**  
4 Palmer House Block, Toronto  
Or F. J. WHITNEY, Gen. Pass. Agent,  
St. Paul, Minn.

*Repairing*  
*Promptly and*  
*Carefully*  
*Executed*

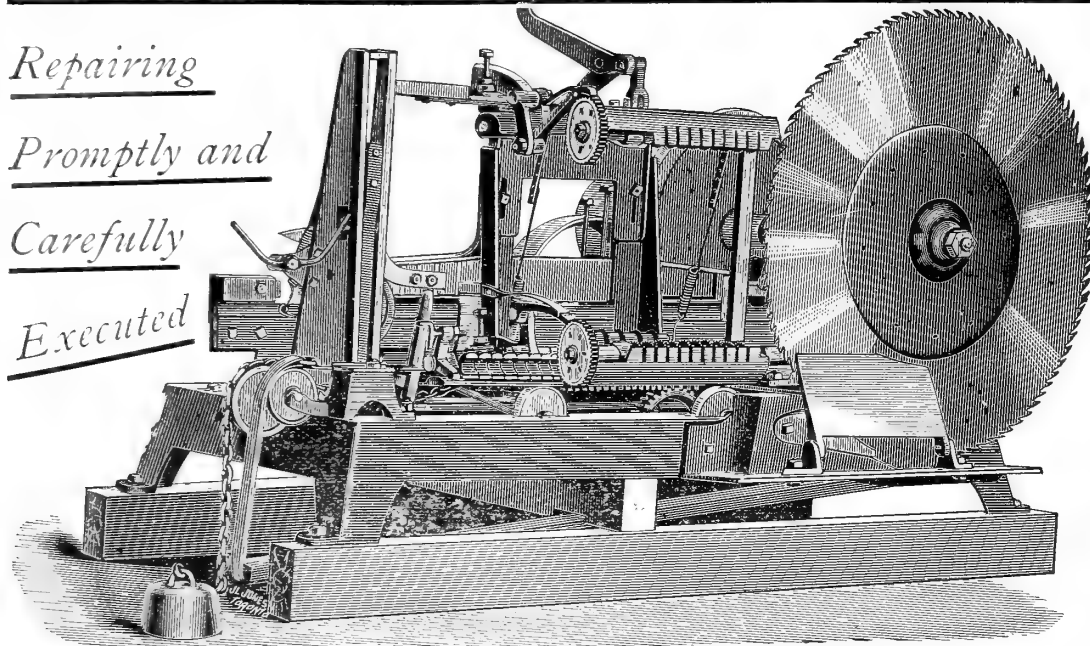

**B. R. MOWRY & SON**

MANUFACTURERS OF

**Saw Mill**  
**and Shingle Mill**  
**Machinery.**

*Shingle Machinery a Specialty.*

**The "BOSS" SHINGLE MACHINE**

Manufactured by us is acknowledged by practical men to be the best machine in the market.

**GRAVENHURST, ONT.**

**The \*XXX\* Saw \*Gummer \*and \*Sharpener**

**HAS NO RIVAL**

**For Variety, Capacity or Quality of Work.**

OR FOR

**Simplicity, Durability, Cheapness.**

Will take saws from 6 inches to 6 feet diameter, sets the saw forward one tooth at a time automatically. Sharpens any saw (rip or cross-cut) perfectly. Giving the teeth any desired pitch or bevel, and making all the teeth exactly alike. Will sharpen 20 teeth in ordinary mill saw in One Minute, or 100 teeth in shingle saw in four or five minutes. The cut shows outline of mill saw 54 inch dia. Patent applied for.

GILMOUR & Co.  
Lumber Manufacturers and Dealers.  
F. J. DRAKE Esq, Belleville, Ont.

Trenton, Ont., 26th Aug., 1891.

Dear Sir,—Your Patent Saw Sharpener is giving us good satisfaction. We average about one hundred thousand shingles per day, and sharpen the saws for both automatic and hand-feed machines with your Sharpener. As it keeps the teeth all perfectly uniform it must be easier on the machine and sawyer too. It causes also a great saving in files. We now only use about one 10 in. file per week. Before putting in your machine we used about six per week. As regards your Improved "XXX" Shingle Packer—they work first rate, and are the only machines we could get that would press tight enough. We consider them the best we ever had.

Yours truly,  
GILMOUR & CO.

**MANUFACTURED ONLY BY**

**F. J. DRAKE**

**Belleville, Ontario.**

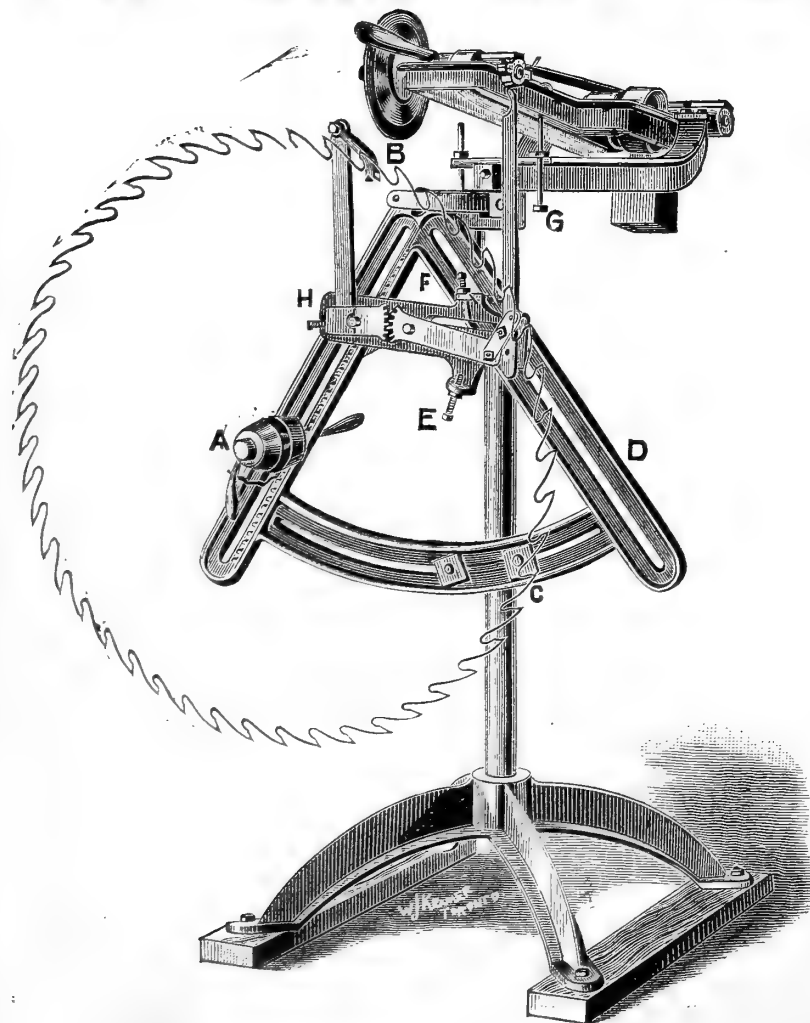

Cant Dogs, Peavies,  
Skidding Tongs,  
Pike Poles, Coldshuts,  
\* Lumber Bob Sleighs. \*

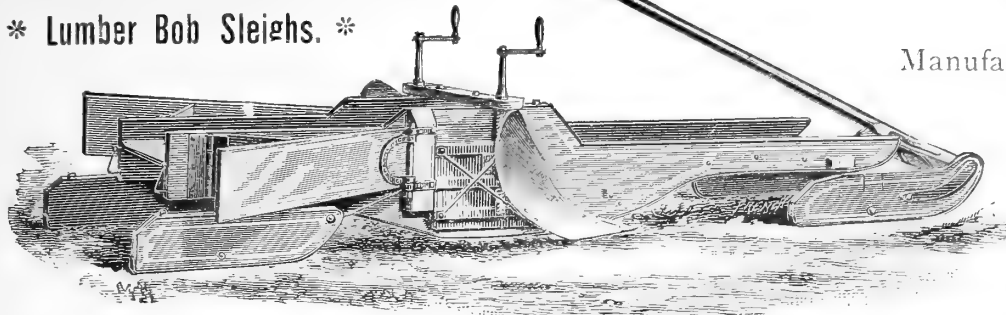

# J. Muckleston & Co.

Kingston, Ont.

Manufacturers of RED TOP LINE

LUMBERMEN'S \* TOOLS.

BRAZEL'S PAT. SNOW AND SIDEWALK  
PLOWS.

DODGE PATENT

## Wood \* Split \* Pulleys.

*We guarantee 30 to 60 per cent. more  
Power with same belt.*

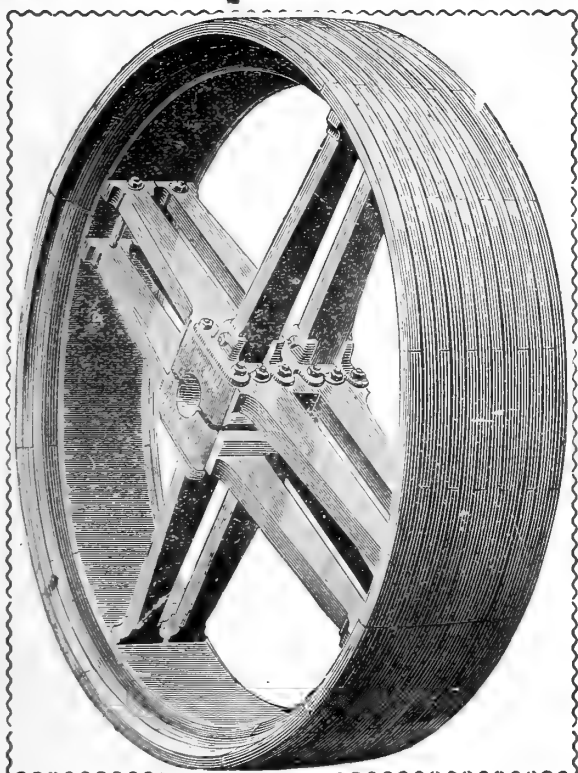

*Every Pulley guaranteed strong enough  
for Heaviest Mill Work.*

All Sizes in Stock. Send for Catalogue.

**DODGE WOOD SPLIT PULLEY CO.**  
83 King St. West, Toronto.

WHEN YOU ARE IN NEED OF **PRINTING**

You will consult your own interests by sending your order to

**THE CANADA LUMBERMAN JOB DEPT. \***

If you are in need of Stationery for your office, shanties or drives, let us know your wishes and we can guarantee that both our work and prices will please you. Address, The Canada Lumberman Job Dept., Canada Life Building, Toronto, Ont.

## DONOGH & OLIVER,

Wholesale Dealers in

# LUMBER

OFFICE:

Nos. 213, 214 and 215, Board of Trade Building,

COR. YONGE AND FRONT STS.

TORONTO, ONT.

\*\*\*\*\*  
**Advertising** IN The Canada Lumberman **PAYS**

Write for Rates.

\*\*\*\*\*

**OUR FRICTION GRIP PULLEYS**

ARE THE ONLY SPLIT GRIP PULLEYS & CUT OFF COUPLINGS MADE. GIVE EVERY SATISFACTION AS DRIVERS OR DRIVEN PULLEYS. FULLY GUARANTEED.

**WATEROUS ENGINE WORKS CO**  
BRANTFORD, CANADA

ELECTRIC LIGHT  
PLANTS

THE  
**THOMSON-HOUSTON**  
AND  
**THOMSON SYSTEMS.**

FOR MILLS AND  
FACTORIES.

THE ROYAL ELECTRIC CO. ADDRESS 58 WELLINGTON ST. MONTREAL, QUE.



80 H.P. CUT OFF COUPLING.

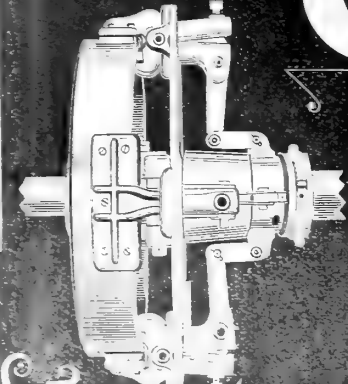

# GRIP

Pulleys & Cut off Couplings.

INCHES 10 X 3 TO INCHES 10 X 30

FEET 10 X 30

SPLIT OR SOLID

GUARANTEED.

AFTER USING YOU WONDER HOW YOU MANAGED WITHOUT IT.

WATEROUS ENGINE WORKS Co. Brantford, Can.

A FEW RECENT SHIPMENTS.

General Buss, S. Paper, S. B.C.	2-24x10 in. face	W. H. McCordick, St. Catharines	1-30x 9 in. face
J. L. Spence, Mill, Toronto	1-40x 9	Waterous Engine Works Co., St. Paul, Minn.	1-30x 9
I. N. G. & Co., Brick Works, Toronto	1-32x14	J. A. K. Drummond, (elevator work) Manitoba	2-20x 6
Dowling & Leighton, Furniture, Harrison	1-24x 6	A. Harris, Son & Co., Brantford	2-18x 8
Toronto Radiator Co., Toronto	1-40x 7	Letang & Letang, Montreal	1-12 in. Sprocket
Taylor Bros., Brick Works, Toronto	1-36x14	Petit Bros., sawmill & stave works, Comber	3-64x17 in. face
J. J. Coulter, Toronto	1-22x 9		2-Couplings.
Nanaimo Electric Light Co., Nanaimo, B.C.	2-30x 8	Adamson & Co., (for elevator work) Manitoba	1-24x 7 in. face
For Elevator Work, Manitoba	1-24x 8	J. Morrison, (for lathes) Toronto	1 pair 12x 4
	7-24x 8	Ogilvie & Co., Grist Mill, Seaforth	1-24x 7 in. face
W. Milne, Sawmill, drive bull-wheel, Stayner	1-16x10		2-28x 6
Windsor, Sandwich & Amherstburg Electric Railway, Windsor	2-48x16	American Mill Building Co., Stratford	3-40x13
British America Starch Co., Brantford	1-48x14		2-28x13

Many, after trial, make further purchases of our Pulley.

Ordered from 7th to 27th October.

North American Mill Building Co., Stratford	2-28x13
Practical School of Science, Toronto	1-36x26
Riordon Paper Co., Merriton (their 5th order)	1-24x 6
Walker, Mal. Iron Co., Walkerville	1-42x10
E. B. Eddy Co., Hull	1-44x13
Barber Bros. Paper Mill, Georgetown	1-40x12
George Fife Works, Port Hope	1-16x 7
Tallman & Son, Brick Works, Beamsville	1-24x14
George Fife, Toronto	1-46x14
George Wright, Fort Corington, N.Y.	2-24x 8
E. B. Eddy Co., Hull (2nd order)	1-64x10
	2-68x14
Firstbrooke, Toronto (3rd order)	3-44x10
	3-42x 9
	3-48x 8
North American Mill Building Co., Stratford (5th order)	3-30x11

SPECIALY NOTE

Grips always motionless when pulley out of clutch.  
 Not necessary to stop an important shaft with a dozen pulleys on it to adjust an unimportant pulley.

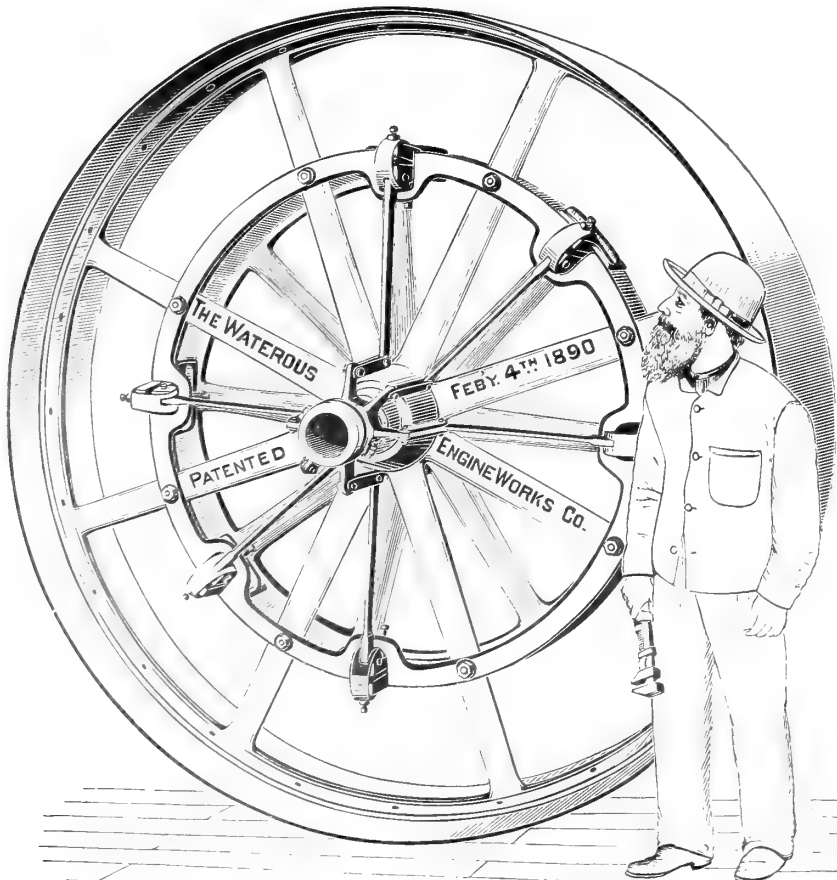

93 x 22 in. Face Pulley Furnished Royal Electric Co.

A FEW REFERENCES FOR GRIP PULLEYS AND COUPLINGS.

Martin, Mitchel & Co., Elevator	Winnipeg	3-78x 6
Cookshire Mill Co. (Saw Mill)	Cookshire, Que.	5-48x12
P. & A. McGibbon, Saw Mill	Lachute, Que.	1-33x16
J. C. Wilson & Co., Paper Mill	Lachute, Que.	2-36x12
E. Buse, Saw Mill	Vancouver, B. C.	1-48x12
Waterous E. W. Co.	Brantford	14-36x 8
Riordon Paper Mills	Merriton, Ont.	4-36x 8
Globe Printing Co.	Toronto	2-43x12
Brooke Woolen Co.	Simcoe	1 Split-30x 6
Hall & Price, Saw Mill	Quebec	3-36x12
George Erb	Winnipeg	1 Split-36x12
A. A. Benson	Montreal	1 Split-36x12
W. H. Law	Peterboro	1-24x 6
Northumberland Paper Co.	Campbellford	1-36x12
Electric Light Co.	Rat Portage	1-48x12
R. Lang & Son, Tanners	Berlin	1-30x 8
Wisner, Son & Co.	Brantford	1-34x 9
W. Sutton, Grist Mill	Simcoe	1-32x10
E. Lavendaro	S. America	4-90x16, 60x13
Miller & Bunting, Veneer Works	St. Catharines	1-33x10
Hunt Bros., Electric Light and Mills	London	6-48x 9
		5-56x12
		7-72x16
S. Frank Wilson, Publisher	Toronto	1-46x13
Kuntz Brewing Co., ice elevator	Hamilton	1-30x 8
W. B. & S. Anglin, Saw Mill	Kingston	1-36x14
C. S. Hyman & Co., Tanners	London	1-30x 8
American Watch Case Co.	Toronto	1-26x 9
M. C. Keith, Saw Mill	Central America	1-22x 8
Westman & Baker, Machinists	Toronto	1-24x 6
A. Harris, Son & Co.	Brantford	1-48x12
British American Starch Works	Brantford	2-48x12
North Pacific Lumber Co.	Port Moody, B. C.	1-48x12
Firstbrook Bros., Box Makers	Toronto	2-42x 8
Bertram & Co., tool makers	Dundas	Duplex-42x12
James Morrison, brass works	Toronto	1-36x12
		2-36x12
Canadian Copper Co.	Sudbury	1-48 in. Sprocket
Clough & Co., Elevator	Lennoxville	1-18 in. Sprocket
Royal Electric Light Co.	Montreal	3-92x10&22
Gurney Scale Co.	Hamilton	Grip Sprocket
Grand Trunk Shops	Hamilton	Cut-off coupling
British American Starch Co.	Brantford	1-30x 8
W. S. Shaw, tannery	Bracebridge	1-18x 8, &c.

\* NOTE SPECIALLY \* THE SIMPLICITY OF THIS PULLEY.

T. D. FORM I. CANADIAN PACIFIC RAILWAY COMPANY'S TELEGRAPH.

TERMS AND CONDITIONS.

All messages are received by this Company for transmission, subject to the terms and conditions printed on their Blank Form No. 2, which terms and conditions



have been agreed to by the sender of the following message. This is an unrepeatable message, and is delivered by request of the sender, under these conditions.

W. C. VAN HORNE, President. CHAS. R. HOSMER, Man. Telegraphs. B. S. JENKINS, Supt., Winnipeg. J. WILSON, Supt. New Westminster, B.C. HOMER PINGLE, Supt., Toronto. JAMES KENT, Supt., Montreal.

NO.	SENT BY	RECD BY	CHECK
5	Am	St	19 Collect
Time 850		Nov 24 1891	
From Montreal		23	
To Waterous Eng. Works Co			

Friction pulleys installed by you so far giving entire satisfaction have not been run with full load yet

The Royal Electric Co TO SECURE PROMPT DESPATCH SEND REPLY TO



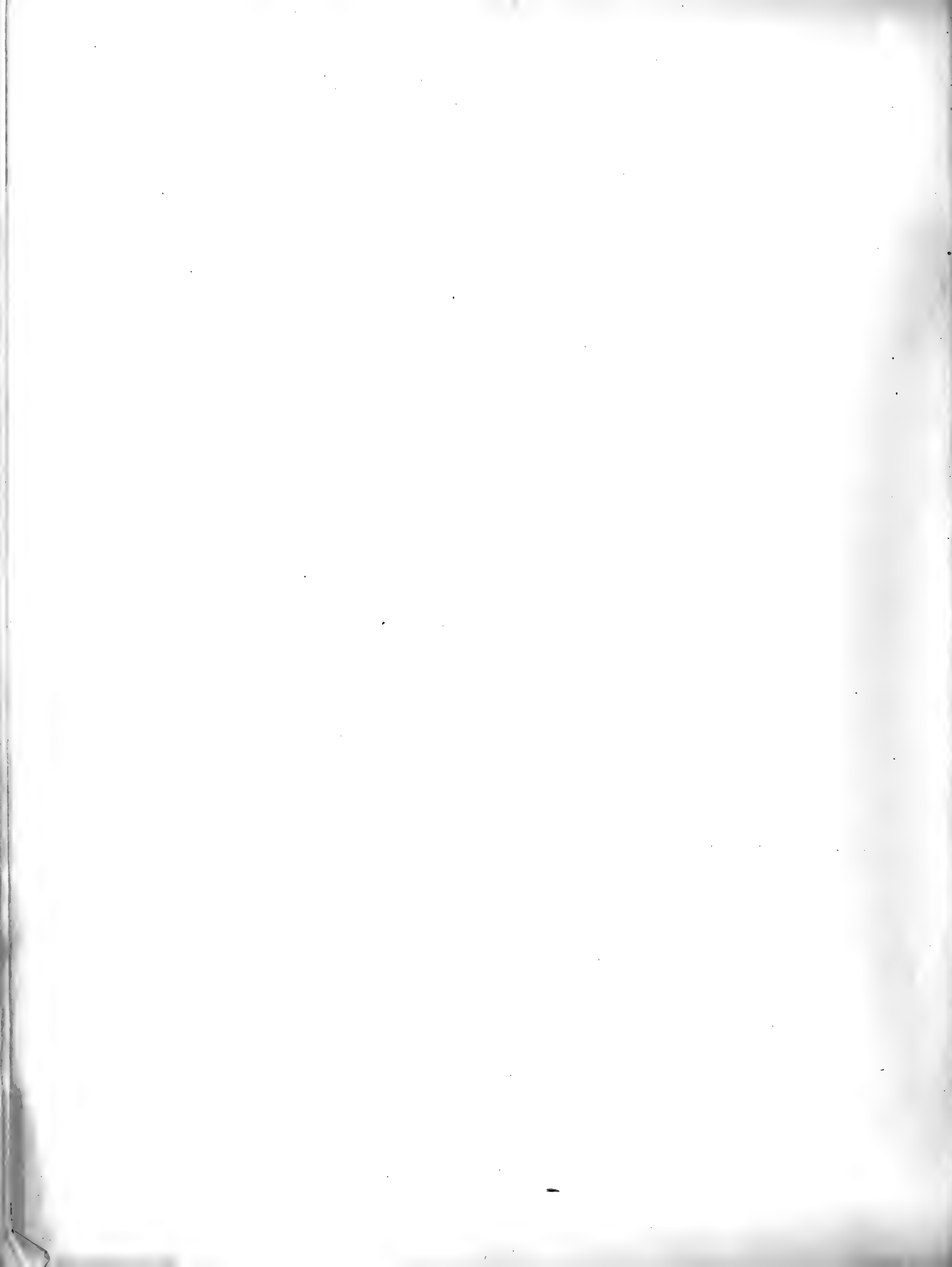







R



