

UNIV. OF  
TORONTO  
LIBRARY

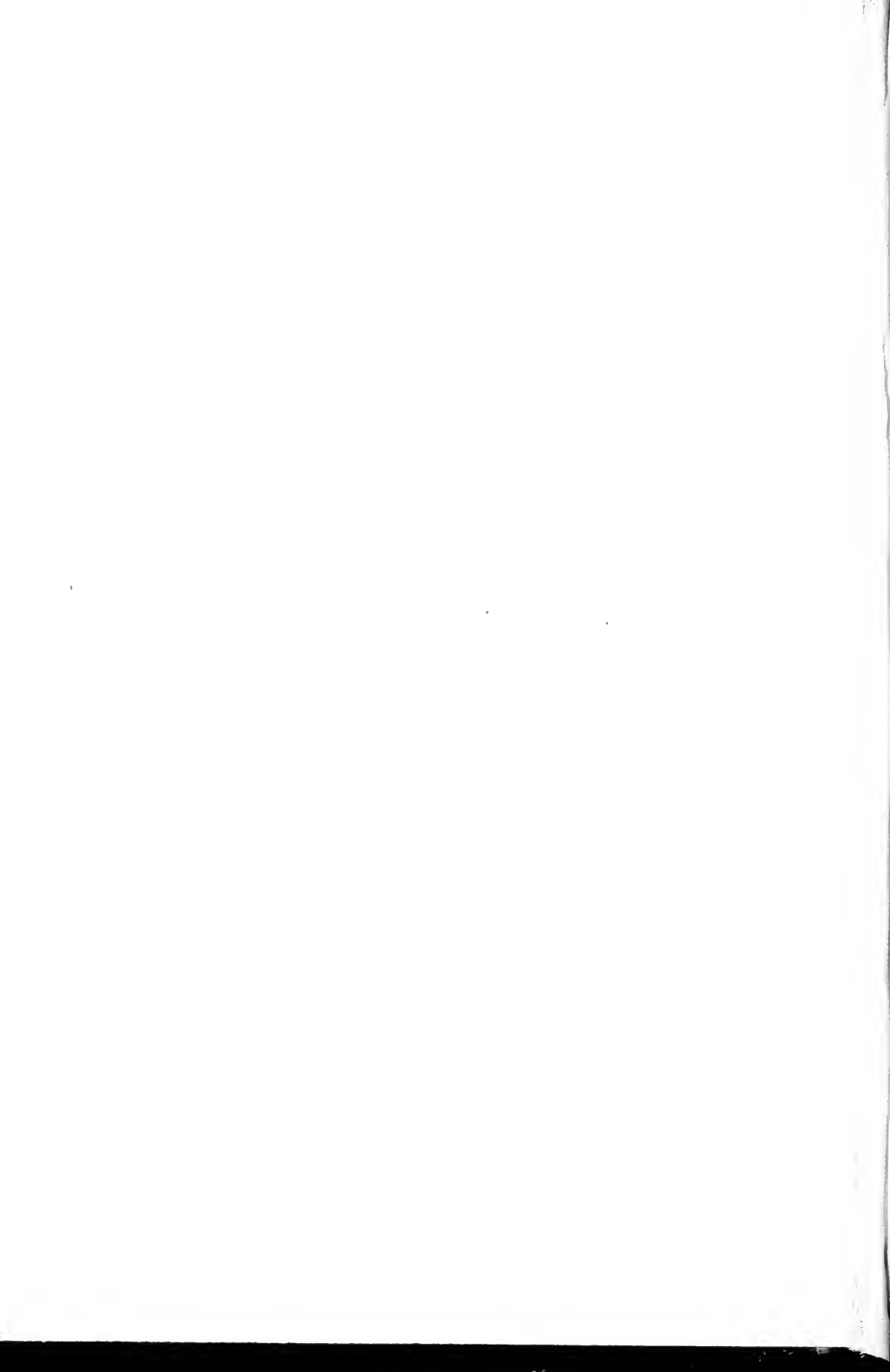

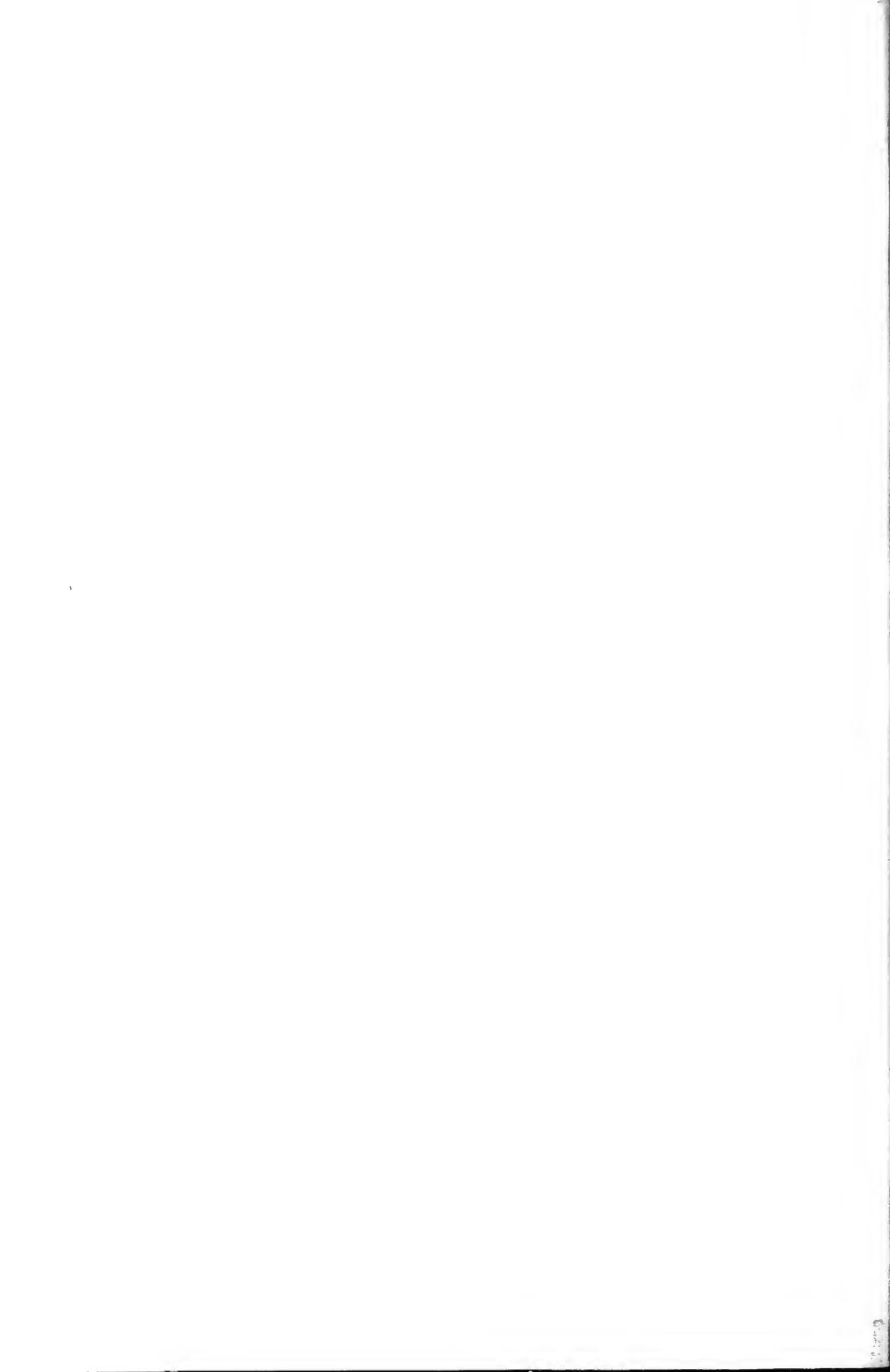





Canadian Forestry Journal  
January 1919



INDEX FOR 1919

56443  
12/10/19

Chief Articles Published in Canadian Forestry Journal.

| SUBJECT.   | MONTH | PAGE | SUBJECT  | MONTH | PAGE |
|--|-------|------|--|-------|------|
| A land where the forest is autocrat .....                | Jan.  | 25   | Is there profit in planting trees?                 | Sept. | 368  |
| Aeroplane wood reserve.....                              | Jan.  | 30   | Jack Miner and his wild fowl                       | March | 99   |
| Australia steals a march on Canada .....                 | Feb.  | 53   | Lumbermen and the tree snuppy                      | March | 115  |
| A land of forests without forestry                       | May   | 212  | Making of a spruce tree.....                       | Feb.  | 59   |
| A better plan for selling timber                         | May   | 217  | Miracle of Gascony's pine.....                     | Feb.  | 61   |
| Airship service in forest areas..                        | June  | 249  | Making forestry pay its way....                    | July  | 314  |
| A question for New Brunswick                             | July  | 308  | Maple sugar pays Quebec yearly fortune .....       | Dec.  | 491  |
| Aircraft and timberlands.....                            | Nov.  | 435  | Ontario must face these facts now .....            | Dec.  | 483  |
| Building up new trade means building new forests.....    | Jan.  | 6    | Odd study of tree stumps.....                      | Dec.  | 498  |
| B.C. reduces fire hazards.....                           | April | 152  | Planting up the irrigation block                   | Jan.  | 5    |
| Business plan for western forests                        | May   | 203  |  | March | 110  |
| Blocking sand dunes with trees                           | June  | 353  | Proposed British Empire Forestry Association ..... | May   | 207  |
| Big companies try our forestry methods .....             | Oct.  | 408  | Prevention of shade tree butchery                  | June  | 251  |
| Coupling the forest to the fruit farm .....              | Jan.  | 8    | Planning a prairie tree plantation                 | June  | 255  |
| Civic plan for street trees.....                         | March | 106  | Paying our debts with scenery..                    | June  | 259  |
| Canada starts aerial patrol.....                         | May   | 220  | Planting suitable shade trees...                   | July  | 292  |
| Canada's forests as an Imperial asset .....              | June  | 290  | Putting back a new forest.....                     | July  | 306  |
| Cash value of shade trees.....                           | July  | 297  | Practical utility of planes in forestry .....      | Nov.  | 470  |
| Clearing the forests of debris..                         | July  | 327  | Reconstruction and the call of the forest .....    | Dec.  | 511  |
| Cruising mahogany in Central America .....               | Sept. | 345  | Rural school plantation.....                       | Jan.  | 15   |
| Canada's forests as a crop.....                          | Oct.  | 387  | Returned soldiers in forestry courses .....        | Feb.  | 55   |
| Does the West need forests?..                            | March | 118  | Red belt injury in B. C.....                       | April | 147  |
| Decay in shade trees and tree repairs .....              | April | 176  | Returned soldier and forest jobs                   | April | 164  |
| Effect of trees on rainfall.....                         | Feb.  | 54   | Reforestation now necessary..                      | Oct.  | 399  |
| Experiments in scientific cutting                        | April | 169  | Surveying by camera from the air .....             | Oct.  | 420  |
| Fertilize your shade trees.....                          | April | 169  | State's duty in managing forests                   | Jan.  | 20   |
| Floods and erosion, cause and cure .....                 | April | 159  | Tree soldiers of France.....                       | Feb.  | 66   |
| Forests of Central Africa.....                           | April | 160  | The day after tomorrow.....                        | Feb.  | 68   |
| Forestry Progress in Newfoundland .....                  | June  | 245  | Trees are the best memorials...                    | Feb.  | 76   |
| Forests of South America.....                            | June  | 264  | Tree planting work in Quebec                       | May   | 195  |
| Forest's losing fight in Arctic Canada .....             | July  | 303  | Tree wireless - a new application .....            | July  | 309  |
| Fire Protection on Crown lands                           | Oct.  | 395  | The State as boss of its forest properties .....   | Sept. | 348  |
| Fighting bad years by tree-planting on the prairies..... | Nov.  | 444  | Utility of the windbreak.....                      | Nov.  | 453  |
| Forest playgrounds built by civic government .....       | Nov.  | 451  | Value of prairie windbreaks...                     | Dec.  | 507  |
| How to plant memorial trees...                           | May   | 196  | Victoria launches into State forestry .....        | Dec.  | 503  |
| How to attract birds to the home                         | Sept. | 339  | World demand shortens life of our forests .....    | Mar.  | 124  |
| Hatching trees by the million ..                         | Sept. | 355  | Windbreaks for orchards.....                       | Feb.  | 79   |
| Insect foes of the forest.....                           | Jan.  | 12   | When trees grow - a novel study                    | April | 162  |
| Imperial forest policy.....                              | Feb.  | 56   | Working for posterity .....                        | Sept. | 351  |
| Insects and fungi damage.....                            | May   | 219  | What tree planting does for prairie farmers .....  | Nov.  | 442  |
|  |       |      | Zaps and forest patrolling .....                   | Apr.  | 155  |

## THESE MEN ARE INVESTORS IN CANADA'S FUTURE

By no means have all the members of the Canadian Forestry Association had an opportunity at the date of this issue, of taking a Contributing Membership for 1920 at a cost of five dollars. At the time of publication, February 11th, the following had accepted responsibility as Contributing Members. The gift of a few extra dollars over and above the normal membership fee, is a great help in carrying out the Association's programme. Without Government connections and with no commercial affiliation, the Forestry Association is forced to depend upon the good-will and enthusiasm of its members. To this we appeal in full confidence. It remains with the body of membership to decide whether we shall appoint a Resident Western Secretary and a Children's Lecturer, to carry the potent message of forest conservation to classes and localities not now within our reach.

|                             |                               |                            |
|-----------------------------|-------------------------------|----------------------------|
| Joseph Allison              | H. A. Downs                   | Miss Alice McLennan        |
| Hon. G. E. Amyot            | E. M. Dechène                 | Sir W. R. Meredith         |
| J. H. Ashdown               | R. J. Dale                    | Miramichi Lumber Co.       |
| Abitibi Power & Paper Co.   | G. Durnford                   | Fraser Napier              |
| W. G. M. Byers              | C. E. Edmonds                 | Hugh Paton                 |
| Theo. A. Burrows            | F. J. Elliott                 | John Penman                |
| Hon. N. A. Belcourt         | C. E. Friend                  | Price Brothers & Co.       |
| Frank K. Brown              | W. E. Fish                    | T. M. Partridge Lumber Co. |
| Chas. Beck Mfg. Co.         | Thomas Fynes                  | Albert F. Park             |
| J. B. Beveridge             | Fassett Lumber Co.            | C. E. L. Porteous          |
| H. L. Bradbury              | Hon. Sydney Fisher            | R. W. Reford               |
| Patrick Burns               | Mrs. R. C. Fisher             | J. S. Russell              |
| W. A. Begg, K.C.            | Sir Joseph Flavelle           | Senator E. D. Smith        |
| O. B. Brown                 | John D. Flavelle              | Shives Lumber Company      |
| Walter A. Black             | E. J. Freyseng                | R. Southam                 |
| E. R. Bremner               | J. L. Goodhue & Co.           | Cecil Sutherland           |
| John Beattie                | J. N. Greenshields, K.C.      | Soper Lumber Co.           |
| Mark Bredin                 | C. S. Gzowski                 | St. Maurice Paper Co.      |
| George Boulter              | Alex. B. Gordon               | Geo. H. Stacey             |
| W. G. Clarke                | Peleg Howland                 | T. K. Smith                |
| Hugh J. Chisholm            | A. C. Hardy                   | Hon. E. A. Smith           |
| R. S. Cassels               | Lieut.-Col. J. W. Harkom      | Angus Shaw                 |
| J. H. Connor & Son          | R. K. Hope                    | Stetson Cutler & Co.       |
| James G. Cane               | C. H. Johnson & Sons, Limited | Shevlin Clarke Co.         |
| R. J. Christie              | Keewatin Lumber Co.           | Nap. Thomas                |
| Alfred Collyer              | Keenan Bros, Limited          | A. St. L. Trigge           |
| E. Coatsworth               | Geo. M. Kelley                | C. H. Waterous             |
| Can. Land & Immigration Co. | Louison Lumber Co.            | W. J. Williamson           |
| A. E. Cross                 | O. Lefebvre                   | Mrs. H. D. Warren          |
| L. Cushing                  | C. B. Lowndes                 | F. C. Whitman              |
| J. O. Cameron               | D. McLeod                     | F. H. Wilson               |
| James Cooper                | Hon. Honoré Mercier           | T. Walklate                |
| J. A. Duthie                | José A. Machado               | E. R. Wood                 |
| S. F. Duncan                | E. W. Mudge                   | Robert B. Whiteside        |
| H. R. Drummond              | McAuliffe Davis Lumber Co.    | Henrk K. Wicksteed         |
| C. Draimin                  |                               | Cyril T. Young             |



# Canadian Forestry Journal

VOL. XIV:

JANUARY, 1919

No. 1

## RECONSTRUCTION IS A CONSERVATION QUESTION

*By Gifford Pinchot, Former Chief Forester of the United States.*

December 9, 1918.

How can we make use of the earth in order to make its forests and waters, lands and minerals, more available for the service of humanity than ever before—more effective toward the greatest good to the greatest number for the longest time?

That is the fundamental question in reconstruction. The second question is, How shall the benefits from the use of the earth be distributed so that more people will be prosperous and happy than ever before?

Reconstruction is a conservation question, and can not be handled successfully unless the conservation point of view is fully kept in mind.

In many ways the forest is the fundamental natural resource, for it not only supplies a basic raw material of modern civilization, but makes it possible for us to get and use the other raw materials which it does not itself supply. Without wood, men have not advanced beyond the Esquimaux stage. Reconstruction can not be successfully handled by neglecting the forests.

You in Canada are more fortunate than we in the United States in having begun to save your forests before destruction had advanced to the point it had in ours. You have begun to prepare your plans for reconstruction earlier also. I



MR. GIFFORD PINCHOT  
formerly Chief Forester of the United States,  
and one of the dynamic figures in the forest  
conservation movement on this continent

venture to express the earnest hope that in planning for the new, greater, and more glorious Canada which we rejoice to see emerging from the War, you will keep in the forefront of your minds the FOREST, mother of men and source of prosperity, and that you will build firmly for your immeasurable future in forestry, and in all other branches of the great problem of reconstruction.

GIFFORD PINCHOT.



The planted approach to the C.P.R. Irrigation Offices.



No more 'bald prairie' for this man! A thriving plantation of Spruce and Manitoba Maple at the Watermaster's headquarters, Crowfoot, Alberta.

## PLANTING UP THE IRRIGATION BLOCK



### A Simple Scheme to Offset the "Move-on" Instinct of the Prairie Farmer in the Treeless Home.



A far-seeing scheme of tree planting has been put into effect by the Department of Natural Resources of the Canadian Pacific Railway Company on the irrigation block east of Calgary. Naturally devoid of any tree growth and yet with great potentialities in agricultural production under the stimulus of an irrigation system, it was early realized by the management that no matter how fine the building that may be put up on the bald prairie, it can never be a real home unless there are some trees and shrubs upon the ground. Most of the settlers coming to the irrigated lands had their origin in well treed districts and all of their old associations are very intimately connected with the trees growing about their old homesteads and the leaf-shaded lanes through which they played as children. The aesthetic side of prairie farming is coming to be recognized as having vast practical importance. For example, if a settler can be induced to become interested in the appearance of his farm, particularly to the point where he will plant a grove of trees, it is reasonably certain that, unlike many prairie farmers, he will soon have something more than a transient business interest in the property. Once that attitude is developed it is but logical to assume that the settler will not start out to "mine" the soil with the object of getting as much quick money as possible and then selling out. The Canadian Pacific Railway Company has done a splendid service in encouraging planting of trees around the homes on the irrigation block and has distributed each year, without charge, quantities of trees which have been found by experiment to be hardy in the district. Mr. R. D. Prettie is the Company's Superintendent of Forestry at Calgary.

#### MAPLE SUGAR OPPORTUNITIES.

One of the opportunities open to Canadians is the development of the maple sugar industry, according to a bulletin on the subject of maple sugar issued by the Department of Agriculture.

The production of maple sugar and syrup should have increased with the increasing mar-

ket for luxuries, but have not done so, the bulletin points out. The yearly production of maple sugar, together with its equivalent in syrup, has fallen from more than 22,000 pounds in the eighties of the past century, to about 20,000 pounds during recent seasons.

### THE ASSOCIATION'S MAIL BAG.

"We are in hearty sympathy with the objects of the Forestry Association, particularly with the educational work it is doing."

D. M. McDOUGALL, President,  
Nova Scotia Steel & Coal Co.

"We cannot speak too highly of the effort you are making towards the safeguarding of Canadian forests from fire."

NICOLA PINE MILLS Limited,  
Canford Mills, B.C.

#### RESULTS OF EDUCATION.

##### CANADIAN PULP AND PAPER ASSOCIATION.

Windsor, Que., Dec. 10, 1918.

Canadian Forestry Association,  
Ottawa, Ont.

Dear Sirs:

I notice with great interest among the people throughout the country a gradual awakening to the seriousness of loss from bush fires. So much of this is due to the constant effort of your Association that it is with great pleasure I extend congratulations

Yours truly,

(Sgd.) F. J. CAMPBELL,  
President, Canadian Pulp &  
Paper Association.

# BUILDING UP NEW TRADE MEANS BUILDING UP NEW FORESTS!

By Rt. Hon. Sir George E. Foster, K.C.M.G.,  
Minister of Trade and Commerce.

## A Call to National Action in the Interests of Canada's Future Population.



Editor, "Canadian Forestry Journal."

My deep interest in the subject prompts me to send you this brief reply to your two questions:

1. What in my view is the position assured to Canadian forest products in future export markets?

In respect to this the situation is obvious. For nearly four years and a half the most destructive war of the ages has raged over a great part of the world on land, on sea and in the air. It has been a war of tremendous equipments and of most destructive appliances in offence and defence. For this equipment in ships, airplanes, bridges, trench housing and packing construction, the call upon forest resources has been almost incalculable. This call has not been satisfied from the usual timber resources, but has been made with peculiar insistence upon private and public timber areas hitherto little cut, which constituted as it were, great growing reserves for future use. In this way the standing and preserved areas in Great Britain, France, Belgium and Central Europe have been sadly depleted. This, however, is only one side of the picture.

### A World of Bare Shelves.

Whilst this severe and pitiless requisition on standing timber was being made, forces of destruction by virtue of and armed by this very supply were incessantly at work sinking, burning, and battering to atoms structures of all conceivable kinds in which wood formed the material in whole or in part. So that here we have had the merry race of devastation feverishly employing the living material in order through its destruction to destroy the vast accumulation of dead and built in material. It needs but a moment's thought to conceive the effect of this double orgy of destruction upon the world's forest resources. But it will tax the capacity of the best statisticians to display the incalculable loss.



Now when peace comes, the world's shelves are bare, the world's resources are diminished and the world's needs are greater than ever. The deduction is plain.

Canada which possesses large forest resources will be imperatively called upon to contribute to the reconstruction necessities of the devastated portions of Europe.

Organisation, intelligent and economic methods of production and financial credits will do the rest. Are our Captains of Lumber ready? If not, it is time they were "up and doing."

2. Your second question as to the importance of Forest Conservation is, if anything, the more serious of the two.

### When Canada has 25 Millions!

It is so easy to make sweeping generalizations from insufficient data and lack of careful information. So especially have we been led into error, I hope not fatal, in respect to the immensity of our Canadian timber resources. Are they inexhaustible? We have too long gone on practically upon this assumption and the assumption all along has been a false one. And so we have cut and slashed, culled the choice and burned or bunched the rest to dry for kindling new forest fires, and suffered tremendous destruction by both wasteful cutting methods and by preventable fire waste, until to-day those who think and know are pessimistic as to our available supplies of merchantable timber. And in reforestation we have done nothing.

Canada has 8,000,000 people, who have so far enjoyed easy facilities for lumber supplies. But when Canada has 25,000,000 people with their wants, which will certainly not be less than ours of this generation, what will be the sources of supply?

We must provide for our own needs here and now; we must furnish in part from our comparative abundance what our devastated allied countries need to reconstruct and we must, as trustees of the future, keep sufficient for our growing nation.

### Must Improve Our Methods.

The argument need be pressed no further. The conclusions seem obvious. Canada must supervise and improve her methods of cutting and very possibly limit the yearly cut in the interests of future generations. Canada must protect her forests from fire by the wise expenditure of money in guarding and supervision. Canada must set herself diligently to the task of afforestation.

If these conclusions are just, can we not all get together, Governments, municipalities, timber owners, and all thoughtful units of citizenship, to conserve and perpetuate so indispensable and valuable an asset of the nation?

Yours sincerely,

GEORGE E. FOSTER.

Ottawa, Nov. 8, 1918.

## CANADIAN LUMBERJACKS WIN.

Novel features were introduced when forestry troops from Canada, Australia, New Zealand and Great Britain held an athletic and field day "somewhere in France." There were 17 companies represented, 12 of whom were from one district group of the Canadian Forestry Corps. There were contests in cross-cut sawing, log loading, tree felling and log rolling, on land and in water. The Canadians won four of these five contests.

In the cross-cut sawing two experienced lumberjacks, who formerly worked in the neighborhood of the Ottawa River, finished the job in thirty seconds. The second and third prizes were won by men from two other Canadian companies. Speed and neatness were the qualifications required in the log loading. Three Canadian units were winners, the first doing the job in five minutes, twenty seconds.

A French-Canadian won the log rolling in water easily. He was an experienced river driver from lower Quebec, for he quickly put most of his opponents off the logs into the water. The second prize winner was a British Columbian. Three Canadians won the log rolling on land.

The director of timber operations in France gave a cup to the company winning the most points during the day. This cup went to No. 2 Canadian company, with nineteen. A private in No. 26 company, Canadian Forestry Corps, won the gold medal donated by the A.D.S.C., Canadian detached forces. Two men in these same companies made an equal number of points in the athletic events and technical contests, and so the British army forestry officer who offered a cup for the man making the best aggregate, agreed to give each of the two men a cup.

There are 25,000,000 acres in the forest reserves in the prairie provinces and the 'railway belt' of British Columbia. The proportion of forest reserves to total area is very low, in comparison with the ratio regarded as 'good business' by progressive European states.

About \$40,000,000 a year is paid in wages to workers in the forest industries.

The United States possesses about four times as much timber as Canada.



Where the forest maintains the fruit-grower's water supply. Looking toward Pentiction, B.C., showing the Giant's Head Mountain and benches, with the famous Summerland orchards.

## COUPLING THE FOREST TO THE FRUIT FARM

By *Geo. P. Melrose, District Forester,  
Vernon, British Columbia.*

### How British Columbia's Richest Valleys Depend Upon Natural Water Storage of Wooded Mountains.

The Okanagan Valley is one of the richest and most productive of any of the valleys in British Columbia. Its annual export of fruit alone is well in excess of two and a half million dollars, and vegetables, dairy products and livestock amount to as much more.

The valley is in the heart of the interior Dry Belt of the Province, and has an almost semi-arid climate with an average rainfall of about 12 inches in the north and 10 inches in the south. The summers are long and dry, while the winters are short and have a light snowfall. The bulk of the precipitation occurs during the winter months.

#### Distributing Water.

Agriculture in the valley is dependent entirely upon irrigation and numerous water distributing companies and corporations with hundreds of miles of ditches and flumes handle the water between the mountain streams and the farm lands.

As mentioned before, the bulk of the precipitation occurs in the winter in the form of snow. It is heaviest in the mountains and often very light indeed in the valley. This snow lies in the hills all winter and as spring and summer follow it gradually melts, first at low levels and last of all in the high peaks, and finds its way into the streams.

Luckily, the mountains surrounding the Okan-

agan Valley from which it secures its irrigation water are covered with a bountiful growth of trees. The forest extends unbroken from one end of the water shed to the other and from near the bottom of the valley to 5,000 feet above it. Upon these forests depend the whole success of the irrigation systems and the fruit and produce growing of the valley.

A steady supply of water during the growing season of the year is what is required for proper irrigation. The forest makes this possible in the following ways:

First of all they protect the winter snow from quickly melting by shading it from the direct rays of the sun and protecting it from the winds. The snow melts much slower in the woods than in the open, as everyone knows who has been in the woods in the early spring and seen the banks of snow there, while in the open the grass was already green. Thus the run-off from the snow is distributed over a longer period and held till well towards the growing season.

In the forest there is a continual fall of leaves, twigs and cones that gradually decay and form a spongy, half rotten top-layer to the soil called "humus." When the snow melts this humus soaks up an enormous quantity of the resulting water and holds it like a sponge. After the snow has all disappeared and surface run-off ceased, the "humus" starts giving up its mois-

ture by seepage. This process takes a long time and generally keeps a steady supply of water flowing into the streams all summer long. In effect it acts like a huge reservoir, giving up its contents during the growing season when it is most wanted. The "humus" acts in a similar manner with rain that may fall during the summer.

Again, when the humus has soaked up its fill and the water starts to run off over the surface of the ground, the roots and trunks of the trees so retard its speed that it cannot assume flood proportions. The roots hold the soil together so that the little streams cannot wash it away

This causes floods which wash down the soil and rocks into the valley bottoms, silt up farm lands and in some cases has been known to cover an orchard five feet deep in rocks and gravel. When the snow stops melting the run-off is over, but the damage has been done. No further water can be hoped for from that watershed unless there comes a rain and in that case the run-off will be just as quick and the benefits just as problematical.

#### **The Forest Saves Money.**

In all cases where a watershed is tapped for water for irrigation, reservoirs have to be secured. These need only be small in the case of



The foe to fertile valleys. This recent photograph shows an almost total obliteration of the valuable forest cover in the Okanagan Valley of British Columbia. View taken from Kathleen Mountain, looking west.

and so we have absence of floods and pure clear water coming down into the creeks and rivers in the spring.

#### **When Trees are Absent.**

Now consider what happens on a watershed that has been denuded of trees by fire or other cause. These effects have all been actually observed to be the result of forest denudation in different parts of the country. The snow melts quickly in the spring, as it is not sheltered in any way from the sun. The bare mineral soil has very poor absorptive qualities and can soak up little of the water and so the bulk of it must run off over the surface in a very short time.

well wooded watersheds on account of the steady flow of water into them as mentioned above. In the case of denuded watersheds, reservoirs have to be of a huge size to hold sufficient of the spring floods to last all summer. This necessitates great outlay of money and there is constant expense on account of the washing down of earth and rocks and the consequent filling up of the reservoir. Luckily, no such problems are presented in the Okanagan.

Fires are the main cause of the forest denudation and in several cases the flow of creeks in the Okanagan has been observed to become less regular with more flood water in the spring and



At the head of Whiteman's Creek, Okanagan Watershed. Excellent forest cover of Douglas Fir and Lodgepole Pine. The value of this green area in maintaining proper drainage conditions in the fruit growing districts is obvious.



In the Okanagan district, B.C. After the Red Creek fire of 1914, showing weeds only coming up after a very severe burn. This area was thick with Jack Pine and was stripped completely, even the grass cover being removed.



less during the summer, following partial denudation by fire of the forests on the watershed.

### A \$5,000,000 Crop.

From the above points it may safely be concluded that the success of the irrigation system of the Okanagan Valley, and thus the safety of that valley's five million dollar crop is dependent upon the forest cover on the watersheds. For that reason as well as for the intrinsic value of the timber and second growth, the British Columbia forest service maintains a very efficient system of fire protection in action in the Okanagan and so far has been able to preserve the important watersheds intact. Their continued protection rests as much with the public in general and particularly with those who travel in the forests, as with the Forest Service. Most fires are set by human agency and if the

public can be educated to the point where they will set no fires at all, practically 95% of all the fires that occur will be eliminated. The other 5% are caused by lightning. It comes down to this: the output of the Okanagan is in the hands of the people in more ways than one. They must protect their water supply while growing their crops. The Forest Service will maintain its protection system to look after all accidental fires and by constant publicity try to eliminate all fires of human origin.

We are thankful to say that a very commendable public spirit is manifest in the valley and each year we see a little betterment of conditions and a better spirit of co-operation and care with fire on the part of the citizens.

GEO. P. MELROSE.

---

## WHY SHOULD A TREE DIE?

*Dr. Bernard E. Fernow.*

---

So impressed was Dr. Asa Gray with the persistence of individual tree life that he questioned whether a tree need ever die: for the tree (unlike the animal) is gradually developed by the successive addition of new parts. It annually renews not only its buds and leaves, but its wood and its roots; everything, indeed, that is concerned in its life and growth. Thus, like the fabled Aeson, being restored from the decrepitude of age to the bloom of youth,—the most recent branchlets being placed by means of the latest layer of wood in favorable communication with the newly formed roots, and these extending at a corresponding rate into fresh soil,—why has not the tree all the conditions of existence in the thousandth that is possessed in the hundredth or the twentieth year of its age? The old central part of the trunk may, indeed, decay, but this is of little moment, so long as new layers are regularly formed at the circumference. The tree survives, and it is difficult to show that it is liable to death from old age in any proper sense of the term.

However this may be, we know trees succumb to external causes. Nevertheless they are perennial enough to outlive aught else, to be the oldest inhabitants of the globe, to be more ancient than any human monument, exhibiting in some of its survivors a living antiquity, compared with which the mouldering relics of the earliest Egyptian civilization, the pyramids themselves, are but structures of yesterday. These

dragon trees, so called, a genus of the Lily family, found on the island of Teneriffe, off the African coast, are believed to be many thousand years old. The largest is only 15 feet in diameter and 75 feet high. The Sequoias or Big Trees and Redwoods on the California coast are more rapid growers, and attain more than double these dimensions in 3,000 to 4,000 years, which may be the highest age of living ones.

---

## BUFFALO HERDS ARE THRIVING

The current report of the Commissioner of Dominion Parks contains information regarding the national buffalo herds in Buffalo and Elk Island parks.

It is not very widely known that the Commissioner of Dominion Parks has under his care nearly three thousand buffalo, that live under natural conditions, with the same habits of feeding and the same liberty of range, within certain limitations, enjoyed by the herds on the prairies in the early days. These animals are healthy and in splendid condition. Their handsome appearance and the fact that the normal increase is taking place afford excellent proof that they are in their natural surroundings. During the year 1917 there was an increase of 356 buffalo in Buffalo Park, and 28 calves were born in Elk Island park. The report states that the young stock are splendid types and are thriving.

## COMBATTING INSECT FOES OF THE FOREST.

Fires, insects and parasitic fungi are the most destructive enemies of our forests. Each season fresh forest areas are swept by fires or devastated by outbreaks of injurious insects and fungi. The extensive balsam injury in Eastern Canada illustrates the serious nature of these insects and fungus enemies. The primary injury was caused by the Spruce Budworm, and in Quebec Province, although the Budworm outbreak has passed by, thousands of balsams have died from the primary defoliation and great numbers of the weakened trees are dying now from attacks of more recent enemies, notably the Eastern Balsam Bark-beetle, the Balsam Bark Weevil, and a very destructive sapwood fungus.

The insect enemies of Canadian Forests are being studied by the Entomological Branch of the Dominion Department of Agriculture. A bulletin dealing with Canadian Bark-beetles has been issued recently by the Forest Insect Division of the Entomological Branch, written by Mr. J. M. Swaine, Parts 1 and 2 have been published thus far. Part 1, "Descriptions of New Species," describes 40 new species of Bark-beetles from Canada and the Northern United States. Part 2 gives "A Preliminary Classification with an account of the Habits and Means of Control." In the First section of the 2nd part, the beetles and their habits are described, with a detailed account of the interesting and sometimes beautiful system of tunnels cut by the adults and their larvae. The Second section deals with Bark-beetle injuries and the means of control. Bark-beetles are probably our most destructive forest insects. They are very small, dark beetles, varying from one to nine millimetres in length. Both adults and larvae excavate tunnels in the inner bark of trunks and branches of many of our timber trees. When green timber is attacked the multitude of small tunnels girdles the trunk in hundreds of places and the tree usually dies in less than a year from the time of attack. Their most extensive injuries to our forest in recent years have been caused in British Columbia, but they are everywhere destructive throughout the eastern woods. The injury to eastern balsam by the Eastern Balsam Bark-beetle at the present time is a good example. In addition to many "primary" species, which attack and kill green timber, many "secondary" species are always found in weakened and dying trees. These secondary enemies

assist the more destructive species in killing trees, following up the original attack, but are often found initiating outbreaks in green timber on their own account.

### Value of Slash Burning.

The Control Measures discussed in this chapter include the destruction of the broods of beetles during winter by modified logging operations, and properly conducted slash-burning. With the destructive species the winter is passed by the beetles and their small whitish larvae or grubs under or in the bark of the trees attacked by them that summer, and in the green slash and stumps. If infested trunks are removed and treated, by driving for instance, so that the broods in the bark are killed before June, and if, in addition, the slash is burned, the number of the destructive species may be so reduced that satisfactory control is effected in one season. Slash-burning is strongly recommended as an effective method of insect and fungus control.

The Third section gives a short account of the structural characters of bark-beetles, sufficient to explain the technical terms employed in the keys for determination in the section which follows.

The Fourth Section, comprising about 100 pages, presents an arrangement of the Canadian Bark-beetles with keys for determination, so that students and foresters with a little training in the use of keys of this kind may be able to determine the species of bark-beetles for themselves.

### Accuracy Essential.

The control measures depend entirely upon the habits of the beetles, and the habits vary with the species. It is therefore necessary to determine exactly which species is causing the primary injury. There may be a dozen species of bark-beetles in the bark of a group of dying spruce, but only one or two of them will be concerned in the primary attack on the green timber.

The bulletin is fully illustrated with 31 full page plates, twenty-seven of these by the heliotype process, and five text figures, over 265 figures in all. It is distributed free in Canada to those interested in forest protection, and may be obtained through the Dominion Entomologist, Entomological Branch, Department of Agriculture, Ottawa.



Can any part of Canada furnish finer spruces than those of Mr. William Pearce of Calgary? These trees were planted by Mr. Pearce about his residence and are greatly admired.

## MANITOBA 75 PER CENT. UNDER FOREST.

The provinces of Manitoba, Saskatchewan, and Alberta are frequently styled the "Prairie Provinces." While possibly the prairies may be

regarded as their outstanding feature, the term is rather misleading in that it suggests the greater area to be prairie, whereas these prairies, however extensive, occupy only a small percentage of the total area of the provinces. At least 75 per cent of the entire land surface of Manitoba is covered by forests. The entire central and northern parts of the province are still practically unbroken forests. The heaviest growth in Manitoba and Saskatchewan lies generally along the Saskatchewan river from Prince Albert to lake Winnipeg, and extending some miles to the north and south.

South of the Saskatchewan river some of the principal tracts of valuable timber have been set aside by the Dominion Government as "forest reserves." These generally occur on elevated ridges or plateaus. North of the Saskatchewan river, throughout the mining district of this region and extending almost to Hudson bay, the country may be described as wooded, till the "barren lands" and open shores of the bay are reached.

### White Spruce of Value.

Though this forest area is very extensive, it does not represent a high average of value. The hardwoods and most valuable of soft woods are missing, while the growth of prevailing trees is



A closer view of one of Mr. William Pearce's beautiful spruce trees on his grounds at Calgary.



Changing the tune of the prairie to "Home, Sweet Home." A fine growth of Manitoba Maple on the farm of Mr. W. Slade, in the Carseland district, Alberta.

generally retarded. The principal trees of Northern Manitoba include only a few species, namely, spruce, white and black, poplar, tamarack, birch, and jack pine. Of these, the white spruce is practically the only durable species for saw-mill purposes. It grows to a fair size on high land surrounding the lakes, averaging from 18 to 24 inches in diameter. Samples up to 36 inches diameter have been found on the shores of Reed lake. It generally grows tall and straight, up to 90 feet in height, and makes excellent lumber, pulp and paper. The black spruce is a slower-growing tree and does not usually reach such a size as the white spruce. It is found in low swampy ground. Jack pine is found on nearly all dry sandy ridges. It is used extensively for ties. Tamarack grows extensively throughout the district, and is used for poles, fences, ties, and fuel. The poplars, aspens or cottonwoods, and the birches have not yet been found of much commercial importance, but are extensively used locally as fuel.

#### The Fire Loss.

The greater part of Northern Manitoba was covered with a much heavier forest than that at present standing. This was nearly destroyed by disastrous fires many years ago. The present forests are principally second-growth—following such fire. Many regions, for instance, the Burntwood River district, have not reforested.

The cut of timber in Manitoba has been comparatively small, in 1916 being less than one million dollars in value as compared with sixty-

six millions for the whole of Canada. The Finger mill, located at The Pas, is one of the largest operating in the Prairie Provinces, the cut for 1917 being 15 million board-feet. This consisted entirely of spruce cut on timber berths along the Carrot river within the boundaries of Saskatchewan. Three small portable saw-mills are in operation north of The Pas. The Hudson Bay Construction Company operate one at mile 185, for their own use. The Mandy Mining Company have one on Schist lake, while one has recently been installed on Wekusko lake in connection with the Rex mine. The annual cut of these three mills amounts to about half a million feet.

#### A Pulpwood Plant.

Great quantities of wood for the manufacture of pulp are available, and plans are being considered for the erection of a plant at Grand Rapids, where the Saskatchewan river enters lake Winnipeg. Water-power is available at this point, and the location is favourable for the transportation of wood to the site.

Other resources of these forest areas are the extensive bogs and swamps which occur in low-lying parts. While no steps have been taken to utilize them it is believed that they might be made to profitably yield vast quantities of peat. The production of either pulp or peat, however, has yet to be inaugurated, and more definite information must first be obtained with respect to the extent of the raw material available. It is reasonable, however, to expect that great possi-

bilities are in store for industries along these lines.

As pointed out by the Director of Forestry in an address before the Canadian Forestry Association at Winnipeg in 1913, Manitoba may yet become a great forest province. The information in this connection given in the following paragraphs are obtained from this source.

Northern Manitoba offers an attractive field for the practice of commercial forestry. Several European countries, with similar conditions in respect to geological and climatic conditions have made great successes of such ventures, and are deriving handsome revenues from them. Investigations have shown that the rate of tree growth in Manitoba compares favourably with that in Germany, France, and Sweden.

#### Sweden's Example.

The case of Sweden might be cited as an indication of what could be hoped for in Manitoba by following a suitable forest policy. Sweden is a northern country having similar conditions of climate and soil, much of it being

underlain by a granite formation like that of the Laurentian area. It is about equal in extent to Northern Manitoba, its total area being 172,876 square miles as compared with Northern Manitoba's area of 178,100 square miles.

By following a systematic forestry policy during recent years Sweden has placed the industry on a profitable basis, and is now receiving a national revenue and providing employment for thousands of her people, at the same time providing for replenishing the forest supply in proportion to the consumption. In 1905 her wood-working industries included 1,370 saw-mills, 138 pulp-mills and 20 match factories, giving employment to 56,424 people. The government forests themselves employed a staff of 971 rangers and officials, and yet yielded a net revenue of \$2,122,625. The total values of her forest products for the year were \$107,000,000. Comparing this with Manitoba's products of less than one million dollars but with natural conditions as favourable, it cannot but suggest the great opportunities that await the province in commercial forestry.

---

## RECONSTRUCTION!— AND THE CALL OF THE FORESTS!

---

*By Ellwood Wilson, Chief Forester,  
The Laurentide Company, Grandmere, P.Q.*

---



### A Challenge to Canadians to Face Critical National Problems with Courage and Daring.



The effort necessary to win the war has stimulated all the nations engaged to a pitch of effort never before approached. There has been a great awakening and quickening of life both material and spiritual. Old formulas have gone by the board, the old catch words by which the politicians have fooled us have been exposed in all their pitiful nakedness and old abuses which have been tolerated for centuries have been swept away in a day. For some time to come it is going to be harder to fool the people than ever before. We have seen the terrible burden of alcohol almost removed, the nationalization and rational handling of a few of the businesses which make modern life possible, the apportionment of food and coal so that all could have their share, and the curtailment of luxuries. Why can we not continue to be sensible and

patriotic now that the war is over? A very small fraction of the money which has been spent for the war would see the country covered with good schools, with good roads, and our people instructed in the proper care of their health by competent men under a Minister of Public Health. If it was necessary to train our men and to put them in the pink of condition to win the war, why is it not far more important to bring up our children with sound minds and well trained bodies fitted to take their place in our great country and not left to grow up hap-hazard, half starved, uneducated and untrained, some of them condemned to fill the jails, the asylums and the brothels. When our men come back from the front they are going to ask some of these questions and they are going to insist that they be answered in the affirmative. The

world has been made safe politically, now it must be made safe economically.

### **Great Enterprises Ahead.**

The great lesson of this war is the necessity for careful planning of all operations and their correlation. The Japanese in the Russo-Japanese war showed how sickness among the troops could be prevented by careful planning. The Germans showed what a definite national aim and planning can do for a country and their detailed plans and preparations almost won the war at the first rush. The fact that their aim was a wicked one defeated them. It was only when the Allies settled down to coordinated operations under a single head, when they had learned to plan ahead for every possible contingency, that the war was won. Remember how our attacks were planned in the most minute detail. This system should now be employed to make our country the best in the world. We must choose a high aim, to make Canada in every respect a truly great nation.

We must plan first of all for a better educational system. Our present one is inadequate and antiquated, our teachers paid little better than day laborers. We must plan for better housing and hygienic conditions so that our future citizens may grow up sound and healthy men and women. We must teach them their duties as citizens so that they may understand and appreciate their part and duty in our development.

We must plan for good roads which will make it possible for the children in rural communities to take proper advantage of the schools and the farmers to get their produce to market and keep in touch with the outside world.

### **State Control Essential.**

One of the questions which has been waiting for a sensible settlement is that of the care of the greatest of our national resources, our forests. We must face and settle this question at once. We must see that our forests are secured from the fate which befell those of the United States and guard them, by keeping them in the hands of the Governments. The time required for the growth of trees makes it imperative that something should be done at once and that the authority managing them should have a definite policy which shall be continuous. We need land classification so that non-agricultural lands shall not be opened to settlement. Where they have been settled or where settlement has been tried we see misery and squalor, illiteracy and the abandoned farm. We must have adequate fire protection so that carelessness cannot

wipe out millions of dollars worth of irreplaceable timber in a day or so. We must have proper care in cutting so that our supply will be continuous and we must have replanting so that the increasing needs of the future will be taken care of.

### **A Work for Government Services.**

Had it not been for the foresight and carefully worked out plans of the French Foresters in planting up their waste lands and keeping up their supply of timber we should in all probability have lost the war, as there were not enough ships to take over the huge amounts necessary. The planting of the Landes district in France took a lot of courage and entailed the expenditure of millions of dollars but it has paid financially and in the time of need helped to save France.

A scheme is now on foot to reforest the British Isles which will require the expenditure of some fifty million dollars but which will ultimately pay back large revenues and go a long way toward making England independent of the outside world for a large part of her timber and, in case of another war, give her all that she would need.

Here in Canada we need some sort of definite policy for our forests. Our Government Services do little but administrative work and are letting the future pretty well take care of itself. Now that the fire hazard has been reduced by better protection methods, it is high time that plans for the proper use and continuation of our forests should be made and put into execution.

### **Employment for Soldiers.**

Our soldiers who have been fighting abroad have been living out of doors with plenty of exercise and lots of action; it will be very hard for many of them to return to shops, factories and offices and our forests offer ideal employment for them, good physical work in the open, the constant change of scene which nature offers, and work which is fascinating and which has a high end in view. The kind of work is especially valuable for those who have been shell shocked or gassed and there are many kinds of work which can be carried on by those who have been wounded. Many of the returned flying men will be able to find work in the forest protection services where they can engage in patrol work and mapping. The large sections of this Dominion now uncharted can in a few years by means of flying boats and moving picture cameras be completely and accurately mapped. Not only that but the photographs so taken will give us at once the areas and kinds



*"WHEN YE HAE NAETHING ELSE TO DO, YE MAY BE AYE STICKING  
IN A TREE. IT WILL BE GROWING WHEN YE'RE SLEEPING."*

*—Sir Walter Scott.*

of timber which constitute our forests, giving us a complete inventory of this source of wealth with but a small fraction of the cost and time which would have to be expended, using the old methods, and with far greater accuracy.

### **Community Forests.**

As is shown by Mr. Clapp of the U.S. Forest Service in his most interesting bulletin "Forestry and Community Development," Forests are almost absolutely necessary to the best development of agricultural communities. The work on a farm is seasonal, heavy in summer and light in winter and the forest offers winter occupation. Then too the farmer needs firewood, fencing and lumber, all of which can be supplied by the forest. The idea of settling soldiers on farms is a good one—if the soldier wants to become a farmer. Farming to-day, however, is a very technical and highly specialized business and for a man with no previous training or experience to undertake it is rather risky. He is likely to lose quite a little time and money in getting the experience for himself and so become discouraged. In settling returned soldiers upon the land they should not be given land haphazard but

regular communities should be planned for and laid out, which would give much better chances for success. The land should be so laid out that each farm would be near the community centre, either by laying the farms out in units which would lie in a circle around the community centre or on the Quebec system of long narrow farms which brings all the houses close together on the roads and makes all the people neighbors. Only the agricultural land should be cleared and the forest lands left in trees or planted up and kept as a "community forest" which would be managed for the common good and would supply the community with forest products. This has been already tried out and been proved a great success, some towns paying all the municipal expenses out of their revenues from such forests, doing away with local taxes.

Soldiers are so accustomed to companionship that when they first return they are likely to be very lonely and when set down on isolated farms become very homesick and soon give up the life.

The life of the forest is a free, healthy life and breeds a splendid type of men, as witness the famous "Blue Devils," Chasseurs Alpins, and the German Jaeger Battalions.

### Trained Woodsmen Wanted.

One of the great needs in Canada to-day is that for forest "rangers", that is, men who will act as fire-rangers, forest guards, scalers, inspectors of logging operations, drive foremen and the like. The day of the untrained man in the woods is passed. The old wasteful, careless methods must go, and for this we need the trained ranger. The professional forester we have already and he is more and more becoming a factor in the development of the country, but where we need one forester we need one hundred rangers, and there has been no effort to fill this want until recently, a ranger school having been started in British Columbia. With such a school training returned soldiers, this want would be filled and a valuable new craft opened for them, for which their campaign experience would be extremely valuable. They could also be trained as game protectors and guides for both of which there is great need. Canada is not yet fully alive to the immense asset which the tourist traffic would be to her and this should be developed. The wonderful lake countries of Northern Ontario and Quebec only need to be rendered accessible to bring in large numbers of wood lovers who would prove an important source of revenue. But to-day in these sections good guides are almost unknown, the game is slaughtered with practically no attempt at law enforcement whatever.

### The Soldier in Planting.

Another wonderful opportunity for the re-

turned soldier would be in Provincial police forces modeled on the Northwest Mounted Police, whose method has been so successfully copied in New York and Pennsylvania.

With the beginning of planting operations on a large scale by corporations, whose example will soon be followed by the Provincial Governments, a large field opens up for the returned soldier with ranger training. The men who have been over with the so-called Forestry Battalions would be especially easy to train for woods work and should naturally be employed in lumbering operations in this country on their return. The lessons of the French forests with which these men have come in contact should make them valuable to us here.

### The Task Only Begun.

We can well be proud of the work which has been accomplished by our Canadian Forestry Association, which has put Canada well in the van of forestry progress, but we must by no means rest content. We have only scratched the surface, our fight has just begun and we still have many worlds to conquer. The secret of the whole thing is the education of the public in regard to our forest wealth and all that it means to the Country. We must strive first of all to build up an enlightened public opinion and then go forward to the conquest of the great problems which are crying out to us for solution. "Wake up Canada!"

---

## THE PROBLEM OF ONTARIO'S PINE SUPPLY.

By *W. F. V. Atkinson, Chief Forester,  
Spanish River Pulp and Paper Mills.*

---

The forests of Canada, from which practically speaking must come our future supply of wood for all purposes, are now suffering serious depletion and are within a measurable period of exhaustion, not only for export but also for home use, unless some efficient laws and regulations be soon put into effect. Indeed, this disaster is possible within the lives of some of our present citizens if the fact is not quickly admitted and sinks in deep enough to produce a definite and consistent organization to prevent it.

I have no doubt that the intelligence of our citizens will insist in efficiency with regard to their forest estate before total depletion takes

place, but I wish to bring out the point that every season, almost every day, that passes while present methods prevail means a loss to the country as a whole, and to each citizen respectively. If each citizen to-day could realize how much it actually means to himself and to his family in dollars and cents which he, or they, will have to pay out in taxes for their share of this loss, I am sure that the necessary steps to a remedy would be immediately forthcoming. I wish this was as clear and real to all as it is to those of us who have had the opportunity to see and study conditions and the experience to appreciate them.



### Regarding Ontario's Pine.

What should then be done under the circumstances? I maintain that no wood should be cut at all unless it is mature, that is to say, can no longer earn by growth increment sufficient to permit it to remain standing, or is so situated that it is liable to be destroyed before it can be cut down.

The only way this can be done is by selection. This means, speaking broadly, the marking of such trees as may be properly cut, or that must be cut, and the protection of those that must not be cut, and at the same time it entails full inspection and measurement of such trees as are cut. It would no doubt surprise some of our citizens to see 60 per cent of the contents of pine trees felled for lumber, left to rot upon the ground because the quality is not sufficiently good to pay the Crown dues. It would also astonish them to learn that in the so-called pine reserves of the Province, taking the total contents of the stand of timber as a whole, there is no increase or growth increment whatever of the total quantity, and that this condition is not the case where stands of timber are properly operated. These details are only an insignificant part of a great number of conditions which exist to the detriment of the forest unknown to the owners which are in the last analysis the citizens of the Province.

### The System at Fault.

With the present system the officers of the Crown are engaged in seeing that contracts and regulations, made largely by their predecessors, are carried out in the best way possible under the circumstances, and they have not either the time, the authority, nor the means at their disposal to carry on or control the exploitation of the people's forests to their greatest benefit. Even if they knew what was the best method, no fault lies with them, it is in the system.

It is only by continued personal inspection and properly graded instructions and the decision of moot points by a competent staff that the lumbermen can get fair treatment and at the same time be obliged to conform to regulations based on a continuous timber supply. This means a staff of employees not at present contemplated. The required staff should consist under the Provincial Forester, of District Foresters, Assistant Foresters, Forest Examiners, Forest Assessors, and a host of Forest Assistants to be graded and controlled by their respective chiefs and to be subject to promotion as well as to discharge on the recommendation of their

superior officers after examination or appeal to a Board appointed by the whole body, and sitting with the Provincial Forester as its head.

### BIG ORDER OF CANADIAN LUMBER.

Ottawa, Jan. 7.—As the outcome of negotiations carried on by the Canadian Trades Commission for the past month the timber controller of Great Britain will purchase in Canada half a million standards of lumber, equivalent in the Dominion to one billion square feet. The lumber, which is to be of all grades, will be bought under the direction of the timber controller through British brokerage houses and Canadian timber agents in London who will deal direct with the Canadian lumber producers.

It is understood that every Canadian producer who is registered on the lists of the trade board at Ottawa will be given an equal opportunity to sell. There is also to be an allocation of purchases upon a territorial basis, thus ensuring a fair proportion of purchases to Western Canada.

This lumber is to be bought within the next twelve months. It will represent a total transaction in money value of about \$40,000,000.

The necessary Canadian credit which rendered the large lumber transaction possible was arranged some weeks ago between the Dominion government at Ottawa and the Imperial government. This credit is to be availed of to the extent that is rendered necessary by the state of international exchange. The British government is to supply the shipping to carry this lumber to Great Britain. The transaction indicated the character of business which it is expected the trade mission will be able to obtain from now on, particularly upon the continent.

### THE JOURNAL'S QUESTION BOX.

Readers of the Forestry Journal are invited to take advantage of the Forestry Association's facilities for securing authentic answers to questions relating to forestry, tree planting, reforestation, and kindred subjects. A great number of questions are answered by mail and such of these as may have general interest will be used henceforth in the Journal.

Send along your question. We will do our utmost to obtain a satisfactory reply.

You can talk on the long distance now between midnight and 4.30 a.m. for a quarter what it costs during the day; and, speaking of us Scotch again, we see where some folks are going to get very little sleep.

—American Lumberman.



Picture by courtesy Acton Pub. Co.  
Muscular Canadian Lumberjacks at Work in a French Forest.

## SURVEYING BY CAMERA FROM THE AIR

By Lieut.-Col. Cull, D.S.O., R.A.F.

in an address before the Geodetic Survey of Canada, December 3, 1918.

### Photographing Lakes, Rivers, Mountains, and Forest from Aeroplane an Economical and Accurate Method.

EDITOR'S NOTE:—The following most interesting paper by Col. Cull will be eagerly read by all who have developed an interest in the aeroplane and its adaptability to forest surveying and fire detection. Col. Cull has a notable war record, and was brought to Canada to organize the air service in connection with the Canadian naval forces.

Before going into the detailed proposition I would like to briefly touch on the progress of aviation and aerial photography, as well as to submit lines along which, in my opinion, aerial work could be used as an adjunct to survey work.

#### Early Aviation.

As you know, some twelve years ago the first flight of any practical value was carried out in France by the Wright brothers. One is apt to forget about these pioneers, but whatever progress has since been made is in no small measure due to the Wrights. I was trying to get into aviation myself then, and cherish, together with a lot of other people, a very kindly feeling for

them and the country to which they belong. I would like to say, too, that from what I saw of American pioneer flying officers in France; and latterly in my dealings with the United States Naval Aviation authorities over here, in connection with the formation of the Royal Canadian Naval Air Service, I have seen nothing to change those opinions. A few months before hostilities ceased, at a rather critical submarine time, they were very generous and of the greatest assistance to us over here in connection with the Atlantic coast.

During the four years preceding the war fairly rapid progress was made in aviation, particularly by the Germans, who took it up along methodical

military lines and made several records, such as a duration flight lasting twenty-four hours. The British and French were not much behind, but they never tackled the problem as methodically as the Germans did.

### **Aerial Photography.**

As far as I know, nothing much was ever done about aerial photography before the war, the only aerial photographs that were taken probably being more or less amateur efforts with kodaks. When war broke out, everyone had to start in to try to develop aviation as quickly as possible. There is no need for me to tell you what progress has been made during the war as you know already. In every paper you see records of the extraordinary feats that are done nowadays.

### **Military Necessity.**

One point I would like to emphasize is that during the four years of war all this progress has been made along military lines, and machines have been developed to obtain high military efficiency, consisting of very high climbing powers, very high speed, and abilities to maintain this speed at very great altitude.

Now that hostilities have ceased, I think we shall see progress just as rapid, or very nearly so, as during times of war; but machines will be developed along slightly different lines. The doing away with the necessity of carrying machine guns, ammunition, bombs, etc., as well as the necessity for very rapid climbing powers will give machines even more excess power than they possess today, thus allowing the engines to be run more throttled down and, in consequence, improving their reliability and their life—attention will be turned to developing much slower landing speeds than are now possible, which is a most important desideratum, and other advantages, such as increased stability, will result.

### **Commercial Uses.**

With the application of aviation to commercial purposes, I think machines will tend to specialize for the various jobs they will be called upon to perform. For instance, machines intended for mail carrying purposes will still have to possess a high speed; machines intended for passengers or goods will sacrifice a certain amount of their high speed for big weight lifting capacities.

The particular thing I am supposed to be here tonight to talk about fits in very well with the machines as they exist at the present time. As you know, it was the custom on all fronts to make complete and detailed maps by aerial

photography of all trench systems, as well as items of interest in the back areas, such as aerodromes, etc. Aerial photography has progressed out of all knowledge during the war, and the most marvellous photographs are now obtainable from very great heights.

### **Snapping From 20,000 Feet.**

At the beginning of the war, machines used to sally forth with what would now be considered an obsolete camera and take fairly good photographs from low altitudes. As the efficiency of the anti-aircraft defences increased, machines were driven higher and higher, to escape being hit, and in consequence the efficiency of the cameras to be used had to be increased in proportion. Nowadays, photographs are usually taken from some height not below 15,000 feet, and in most cases the height of photographic work is in the neighbourhood of 20,000 or more feet. Cameras used for this purpose have a focal lens of about  $4\frac{1}{2}$  feet and cover a plate 10 by 8 inches. I believe I am right in saying that the photograph taken includes about six square miles of country. The actual cameras themselves are comparatively simple looking arrangements containing a high class, wide angled lens, a focal plain shutter, and some form of plate changing apparatus. The early cameras used the Mackenzie Wishart system, but the manual operation required to work this, under conditions of extreme cold and attention to other necessary duties, such as defence against enemy aircraft, soon produced the more simple changing box which is quite workable with heavily gloved hands and which is capable of carrying fifty to one hundred plates in one lot.

### **Overlapping Pictures.**

When taking a series of photographs, they are usually taken at fixed intervals of time, according to the speed of the machine and the number of plates carried. In all cases, however, they are taken so that each photograph along a certain line overlaps with the one before it and the one after. When one comes to join them together one merely has to pick out a landmark occurring in any two photographs, superimpose it, get the bearings of the photographs and any lines that may be on the photographs coinciding.

In addition, however, to those composite photographs, aerial photography is used very largely from the stereoscopic point of view. By this I do not mean to say that actual stereoscopic cameras are used; but, to take an instance, suppose you are flying along a line in which a particular point occurs, of which detailed information is required. This particular point can

be made to occur in two photographs. What is then done is to cut out the part in each photograph containing the point and paste the two photographs alongside each other, on the usual stereoscopic card. Here it is necessary to get the positions of the two photographs by experiments, as for certain optical reasons, unknown to me, if you put one photograph on the right whereas it should be on the left, the proper effect of height and depth is reversed, although the two photographs may look identical. However, once this is successfully done the combination of the photographs can be used in the usual stereoscope and a very good idea of the proper perspective obtained.

#### **Effects of Stereoscope.**

Another interesting point is that two different photographs giving, for instance, a fuzzy appearance singly can, by viewing stereoscopically, be made to give a very good single image.

Using this method, it is possible to very closely examine positions on the ground, and in case of batteries I know it is possible to tell whether emplacements are made of concrete or of sand bags. This method obviously offers chances of value in the examination of items on the ground which, from a survey point of view, special information is required about.

Before coming over here I was stationed at Dunkirk for the last year, where a great deal of aerial photography was done over places such as Bruges, Ostend, etc., where the Archies were severer probably than anywhere else in the world.

#### **Survey Photography.**

To continue now with aerial photography, as applied to survey work.

When I came over here, I knew practically nothing about survey work. I gather now that photography plays a considerable part in survey work over mountainous country, and that expeditions set out in summer months in order to photograph ranges of mountains from known positions with the idea of getting the heights and positions of the mountains. I have seen some of these photographs taken by the Geodetic Survey and have admired them immensely, but looking at them it struck me that when you photograph a mountain there must be various foothills and minor mountains leading up to the main peak and that photographs taken from one point will not give any idea of what lies between these foothills and the mountain itself nor of what lies behind the mountain. I suppose to obtain particulars of these it is necessary for a

party to go round to another point, at a different angle to the original, and to make another set of photographs from there. This further expedition is naturally a matter of time, and I think it possible that aerial photography may be able to make much of this unnecessary. The machines, working in conjunction with a surveying party and in touch with them by wireless telegraphy or wireless telephony, could receive orders to fly over any particular portion of the mountain and take such photographs as are required. For instance, a photograph taken immediately over the top of a mountain will show the general contour of the mountain and all its couloirs and surrounding peaks. It will give no idea of the altitude of the mountain, but it will certainly show a great deal which a photograph taken from some known point opposite will not show, such as the configuration of the snow fields round the peaks, the distance between individual peaks, and possibly such a photograph might give a good indication of the best method of climbing the peak, if this is required.

#### **Mapping Rivers and Lakes.**

To get away for a moment from mountain work, aerial photography could give very valuable results in the mapping out of rivers and lakes. These particular objects are especially adapted to aerial photography, as it is possible to obtain in one photograph the shape of an entire lake, and a series of photographs of a river will give the course of a river. Without knowing anything about mapping out rivers and lakes, I imagine it must be a case of covering most of the water in boats and fixing numerous positions along the shores by means of triangulation, so that in this case an aerial photograph might be able to dispense with many days of work. Photographs taken over water would also, to a great extent, show the configuration of the bottom, so that unless precise details were required, the necessity of taking soundings could be obviated.

#### **Life of Aeroplanes.**

Many people, without stopping to think, are of the opinion that for the purposes of flying all that is needed is a good looking machine, a pilot, and one mechanic. If one went by the papers one would be apt to think that all that has to be done is for the pilot to step into the machine, the mechanic to give the propeller a twist, and off the machine goes. As a matter of fact, this part of flying is only a very small item, and it should not be necessary for me to say that the whole success or otherwise of suc-

cessful and continuous flying depends on the preliminary organization, and on the organization during the period in which flying is carried out. This involves all kinds of detail, not the least among which is the transportation of the machines, stores, etc., to the point of departure, and in this country this particular item would be quite a serious matter. In a small country like England, it would be quite possible for a machine to fly to the point of departure, thus saving a lot of bother; but in a vast country like this it would be uneconomical, as aircraft engines have only a limited life before they require overhauling and machines would arrive at their final destination, after many stops, in a state requiring several days of careful overhauling, let alone the possibility of breakdown at some of the landing places en route.

#### Public Control.

If Canada has an Air Service my idea would be for any department requiring assistance in the aviation line to make application to the Air Department, stating their wants, and then rely on the Air Department to provide the necessary equipment to cope with the situation. In the early stages of an Air Department, the charge to the department requiring the work would probably be purely nominal, as one of the main wishes would be, to a certain extent, to educate the department and the rest of the public as to the possibilities of aviation. In a year or so, however, it would only be reasonable for the Air Department to send their account in for the actual working expenses; but this would not include any percentage of the cost of stores and spares which were not actually used, as on completion of the expedition these would all be returned, having been kept in good condition in the meantime, and be put back again into circulation, while the personnel would be returned to other duties.

#### Nationalization is Best.

To get off the track of this lecture for a second, aviation run by a private company on a very big scale, embracing as many diverse interests as possible, or as a National Service doing the same, could, in my opinion, be made to well pay for itself in this country, but the scale would, I think, be too big for any company to undertake for some years to come, and so everything points to nationalization here, as a company on a small scale trying to run things economically would only let themselves and the public down, and by their mistakes and shortcomings queer the pitch of aviation with the general public. You may take it as an axiom

that false economy in aviation material and personnel is a great mistake, and that the best cannot be too good. There is good reason for saying that an Air Department should be run as a business concern, showing a balance sheet, as moderate working expenses would show it was being of value to the community, whereas big working expenses would show it was not and that a change of policy or organization was required.

The public are apt, in talking about aviation, to neglect the possibility of lighter than air craft; but with the advent of the efficient semi-rigid ship and very much more efficient rigid ship, based on the old Zeppelin design, I think lighter than air work is going to play a very important part in the future of aviation.

#### Crossing the Atlantic.

Merely to give one instance of this possibility, I want to tell you that the modern Zeppelin, the total weight of which is from 60 tons, can carry sufficient fuel to cross and recross the Atlantic three times, as well as passengers, material, etc., to the extent of 20 tons, all this being carried out at a speed of some seventy miles an hour.

#### R. H. CAMPBELL RECOVERED.

It is with much pleasure that the Journal chronicles the full restoration to health of Mr. R. H. Campbell, Dominion Director of Forestry, who was seriously injured near the Pas, Manitoba, while on inspection duty. Mr. Campbell returned to Ottawa a few days before Christmas and took over most of his official duties.

#### A GREAT SERIES FOR THE 1919 FORESTRY JOURNAL.

Commencing with the February issue, Dr. C. D. Howe, of the Faculty of Forestry, University of Toronto, will write a valuable group of articles for the Canadian Forestry Journal, the first of which will be entitled "The Making of a Spruce Tree."

Every reader in whom the working of Nature has aroused a sense of wonder and curiosity will follow Dr. Howe's stories with eagerness from month to month. Not more than a page of two to each contribution — popularly written and well illustrated!

The first article by Dr. Howe comes in your February number, which will be issued by the Association not later than the 10th of the month.



The Loading Deck at 60th Company Camp, Canadian Forestry Battalion, Vosges Mountains, France. The logs are fir and spruce.



28th Company's Camp in the Vosges Mountains. These mills were designed to cut 20 thousand board feet in 10 hours, but under stress of war average 35 thousand feet, with some record cuts of over 50 thousand feet per ten hours.

# A LAND WHERE THE FOREST IS AUTOCRAT



By *R. G. Lewis, B.Sc.F., late Technical Officer  
with Canadian Forestry Corps in France.*



## In the Jura Mountains, almost every Town runs a Communal Forest to Ease Taxes.

During the war the French forests proved to be one of that country's most valuable assets. Not only did they provide the French Army with lumber and fuel wood, but they also supplied the needs of the American and British forces in France and to a certain extent those of the Italians. Owing to the foresight of the French Forest Service in times of peace the supply was ample in time of war, but in the early days of the conflict men in sufficient numbers were not available for the exploitation. A well-known military authority is on record as having stated that the need of wood in the trenches in 1916 so hampered military operations that, could men have been secured to cut and saw the timber in French forests for the use of the armies, the war would have ended in the fall of that year. This may have been a slight exaggeration but the fact remains that modern trench warfare is enormously dependent on wood. From the "duck board" that floors the trench in the front line to the storehouses at the base there are many uses to which this commodity, and it alone, can be put. Huts for housing troops, plank roads, gun emplacements, trench and dug-out construction all consume lumber in enormous quantities and every advance or retreat means a loss of material and an increased demand.

### 12,000 Canadians Used.

The Canadian Forestry Corps started as a modest battalion cutting timber on some of the large estates in England and Scotland. Its activities were extended to France during the winter of 1916-1917 and being formed into a Corps it grew until it became one of the most important parts of the Canadian force in France. At the termination of hostilities there were at least 12,000 Canadians engaged in cutting down French forests and sawing them into lumber for the French and British armies. Many American Engineer Companies were engaged in work of a similar nature for the American forces, French civilians and Russian troops in France working under the direction of the French Forest Service also made steady inroads into the supply of standing timber. Exact figures to the extent

of this activity are not available, but one thing is certain, that the Forests of France have not been destroyed and they still remain as a valuable asset to the nation and a monument to its thrift and foresight. Is this not a striking argument in favor of scientific forest management?

Although the consumption of wood in France in peace times was so great that the importations were valued at three times the exportations, the administration had adopted the policy of reserving about a quarter of the available supply for emergency. When this emergency arose the timber was available to meet it without borrowing too heavily from the needs of future generations.

French forests are scattered through the farming, grazing and vine growing lands in such a way that no large areas exist at a great distance from settlement and transportation facilities. There is a ready local market for small material obtained from thinning and improvement cuttings, so that the expense of keeping the stands up to a high state of perfection is not great. Defective trees can be removed as soon as discovered and their wood disposed of at a profit for fuel. The result of this was evident to the Canadian lumbermen working in France. Defective material of saw log size was almost unknown.

### Chips and Brush Picked Up.

The utilization is carried out in such a way that practically nothing is wasted, even chips and small brush are removed by the inhabitants for fuel. From the State forest the material is marketed in such a way that the minimum damage is done to the stand remaining. The material is sold, often by auction at a certain price per cubic metre, measured on the stump and including the entire volume of the tree, bark and branches as well as the trunk down to the root collar. There are fines levied for all damage done to the remaining stand, although allowance is made in fixing the rate of these fines for unavoidable damage. The result of this method of selling timber is that the contractor takes the

greatest possible care to cut his stumps as close to the ground as he can, to utilise the branches for fuel and to avoid damaging the remaining trees in felling those he has purchased. The upset price in the case of an auction is so fixed that with reasonable care the contractor can make a fair profit in his undertaking.

### The French Lumberman's View.

Most of us are liable to fall into the error of supposing that scientific forestry is an affair of the government and we are surprised to learn that in France 65 per cent. of the forest area belongs to private individuals, while 21 per cent. is the property of the communes and public institutions. Only 12 per cent. is the actual property of the State. These communal forests are under the administration of the Forest Service to a large extent and their owners pay a small tax per acre for this service of advice and supervision. Even the forests owned by private individuals are subject to State supervision to a less extent. They cannot be cleared or over-cut if such action is considered detrimental to the public welfare.

The inhabitants in and about the forests take an enormous pride in the forests whether they are owned by the State, by communes, or by private individuals. With true French frugality they make it their business to see that the regulations of the *régime forestier* are carried out and that there is no waste due to fires, trespass or careless utilization. This support which public sentiment gives to the idea of scientific forestry is everywhere in evidence. Providing for the needs of the future generation is an essential part of the national spirit of France. I have been asked by many French people who had no direct proprietary interest in the matter why we Canadians cut such high stumps—and we did cut them high according to French ideas when we first started operating—why we broke so many trees in our felling operations and left so much valuable debris after we were finished with an exploitation. I explained that we were working under pressure of circumstances, that the army demanded increased production of lumber in order to win the war even at the expense of some considerable damage to the forest. The answer to this explanation was frequently the question, "What is the use of saving France from the Boche if all our beautiful forests were destroyed in doing so. France cannot exist without her forests. What will our children

and grandchildren do without wood when the forests are destroyed, if the Boche comes or not?" This argument was not sound as we were not destroying the forests, but the extent of public sentiment was plainly shown.

### Municipal Forests.

Respect for the Forest service and its officers is almost universal. We had many occasions to call on Forest Service officers to adjust matters pertaining to damage to private property in connection with our exploitations. The owners realized that the damage was unavoidable and were always quite willing to submit to the arbitration of the Forester and to accept his estimate of the damage.

The communal ownership of forests in France is a very interesting condition for study with regard to the possibility of its adoption in some modified form in Canada. While this form of ownership in France is often the result of an adjustment of feudal conditions, many communities and public institutions have actually purchased forests as an investment for the benefit of their members and the future generation. In the Vosges and Jura Mountains almost every village and town has its communal forest from which it obtains a regular annual revenue. This revenue may consist of the funds obtained from the sale of material cut in the forest applied to local improvements with a resultant reduction in taxes. In many cases dwellers of the commune receive, pro rata, their supply of firewood and wood for fencing, building and construction of different kinds, from the communal forest. In some cases where the population of the commune is small and the forest large and productive the commune becomes a modern Utopia. No local improvement taxes, free firewood, and workwood and a revenue in actual cash, all derived from the wise investment of past generations. The forest being managed under certain State restrictions has become a permanent source of revenue.

R. G. LEWIS.

### GROWTH OF SPRUCE.

It takes about forty years for seedling spruce trees to attain a diameter of one inch, 100 years to make a 6-inch tree, and 150 years to reach the minimum diameter limit of 12 inches established by the cutting regulations for pulpwood in Quebec for white and black spruce, according to the ninth report of the Commission of Conservation.





Building up a new forest nursery, under the Dominion Forestry Branch, at Sutherland, near Saskatoon.

## A NEW TREE SUPPLY BASE IN THE WEST

### One and a Half Million Trees Set Out in the Past Year.

The Tree Planting Division of the Forestry Branch, Department of the Interior, has for the past eighteen years been encouraging the planting of trees by settlers of the prairie in Western Canada. The primary purpose of this planting as planned by the Department is the providing of shelter belts against adverse winds for dwellings, live stock and gardens, and to beautify the home surroundings and later perhaps become a source of supply for fuel. That the Department's co-operative system for the distribution of trees has been an unqualified success is evidenced by the fact that the producing capacity of the 480-acre nursery at Indian Head, Saskatchewan, was reached several years ago. From 54 applicants for trees in 1901, the number

steadily increased until it had reached 5,723 in 1910, and the trees set out each year during this time rose from 58,800 to 2,570,000. It became apparent that if the rates of increase in applications continued it would soon become necessary either to obtain some additional supply or to reduce considerably the number of trees sent out to each applicant. To take the latter step was not considered advisable, since satisfactory growth and protection can not be maintained unless the trees are closely planted, and the Department accordingly proceeded to secure a new nursery site. After careful investigation a half section of land located near the town of Sutherland in the outskirts of the city of Saskatchewan, Saskatchewan, was chosen in 1912. In



Some encouraging results in the planting of hardwood trees at the Sutherland Forest Nursery

selecting the site three points were kept in view, viz., suitability of soil and climate for growing trees; facilities for shipping stock; and the proximity of a temporary labour supply. The Saskatoon nursery is so situated that stock can be shipped by the Grand Trunk, Canadian Northern and Canadian Pacific Railways and serve all the country to the north of Saskatoon and the main lines and branches running east and west of Alberta and Manitoba, leaving the southern half of the provinces to be served by the Indian Head Nursery. Recipients of trees in the northern portion of the provinces are thus saved an appreciable amount for express charges.

The Saskatoon Nursery is operated on similar lines to the one at Indian Head under the direction of Mr. Norman M. Ross, Chief of the Tree Planting Division and the immediate supervision of the Superintendent, Mr. James MacLean. During the first four years of its existence no material was produced for distribution. This time was required to lay out the ground, erect buildings, prepare the soil for seed beds and establish the plantations necessary for the shelter of the nursery plots. In 1916 the first shipments were made to applicants and the number of trees sent out each year from the new nursery have been steadily increasing. In the spring of 1918 over one and one half million trees were distributed. The species included Manitoba maple, ash, Russian poplar, willow and Caranaga. Evergreens are not grown on the Saskatoon Nursery for distribution. At present all evergreen stock is sent out from the Indian Head Nursery. Later, when the newly established shelter belts on the Saskatoon Nursery can provide the necessary protection, the raising of these species may also be undertaken on this nursery.

As yet only a small part of this new nursery is being utilized for the growing of stock. As the demands increase the area will be enlarged. Those portions not best suited for the raising of young trees it is planned to utilize for permanent demonstration and experimental plantations, in the same manner as similar areas are being used on the Nursery at Indian Hed.—B. R. Morton.

### A PINE-TREE AIN'T A MAPLE.

Old Crazy Pete he says to me,  
"A pine-tree ain't a maple tree,

"A tamarack it ain't an oak."  
"Of course," says I, "Now what's the joke?"

"Just this: At times a wife or boss  
(They're much alike it's hoss an' hoss)

"Expect an oak to be a pine—  
Or so, at least, have all of mine."

"I guess that I don't follow you,"  
Says I, "or what you're leadin' to."

"The oak is strong," he says. "It ain't  
As soft as pine for takin' paint.

"For hardness maple sure is good,  
But it don't give like other wood."

"Of course," says I, "they differ; each  
Has its own value—even beech."

"Just so. The man who's built to lift  
Ain't like to have no other gift.

"The man who's handy with his brain  
Won't never bust no lawggin'-chain.

"The good provider may not lead  
In table manners takin' feed.

"Whereas, upon the other hand,  
The loafer's manners may be grand.

"I guess we all are just like these—  
Have certain virtues, men an' trees.

"An' yet some women set an' bawl  
Because their man ain't got 'em all.

"I guess they ought to just be glad  
We had the virtues that we had

"An' not be sad because us folks  
Ain't tamaracks as well as oaks."

*By Douglas Malloch.*

A special article written for the Forestry Journal by Sir John Stirling-Maxwell, of Glasgow, noted champion of the forestry movement in the British Isles, appears in the February issue of the Canadian Forestry Journal.

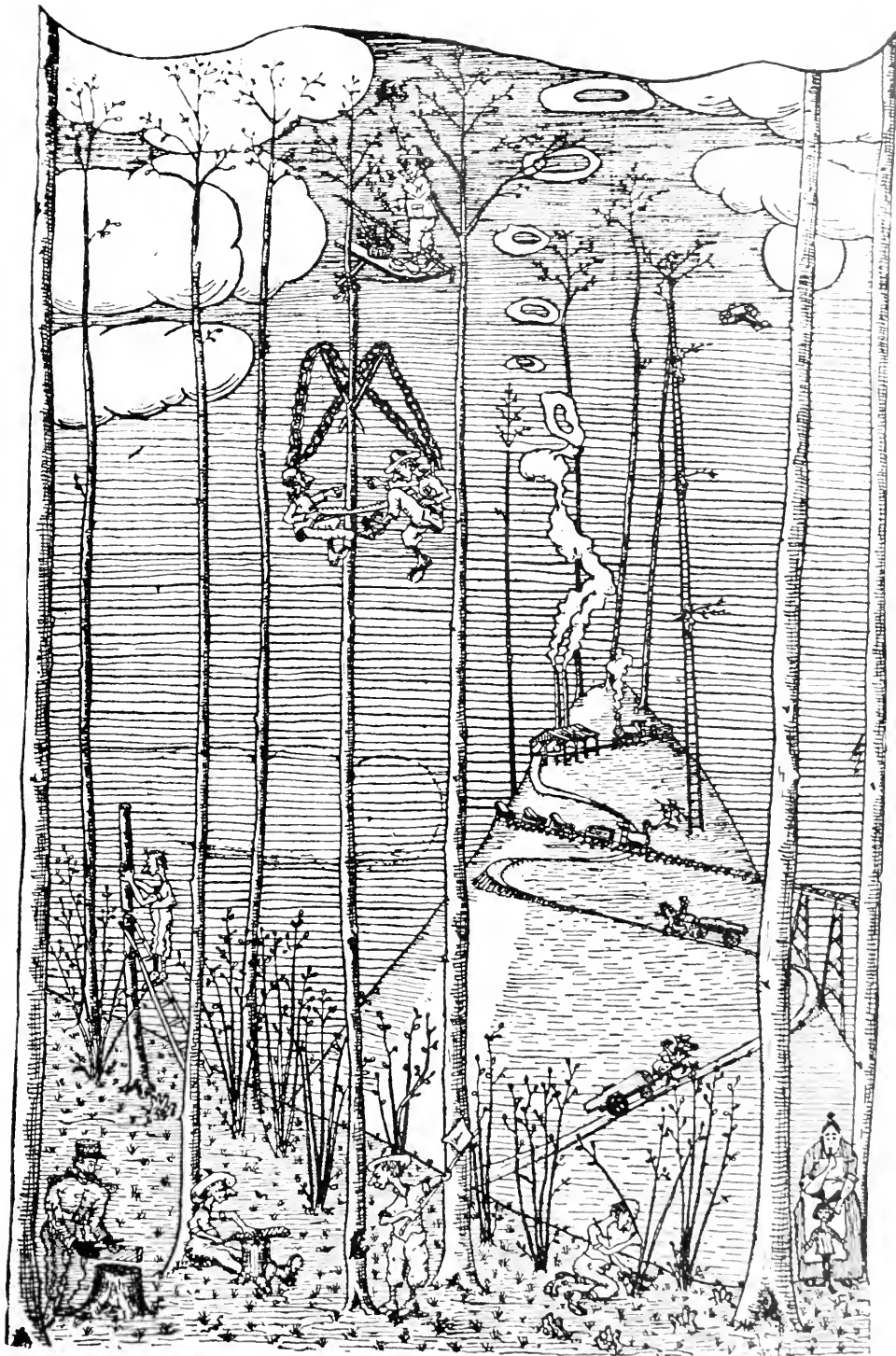

*Fun From the Forestry Camps.*

The above cartoon is taken from a New Year Post Card received from Capt. L. M. Ellis, with the Canadian Forestry Corps in France. As a satire on French forestry and logging methods it is excellent. Note the three operations of cutting off the top, sawing the top log and chopping away the base—all going on at the same time, with a marvellous disregard of consequences. Lumbermen will appreciate the location of the sawmill at the top of the mountain and the long up-hill climb with the logs. To the left a French forester is placing a level on the butt to make sure that the sawing has been mathematically faultless. Tree planting also comes in for its share of attention.



## OUR AEROPLANE WOOD RESERVE

British Columbia Production at Close of War Provided Material  
for 30,000 Planes.

The demands of the war have occasioned the most phenomenal development of many industries. Not the least among these is aeroplane lumber in British Columbia. This province, in the thirteen months since the first request came from the Imperial Government for this material, has provided approximately 9,000,000 feet of Douglas fir and 26,000,000 feet of Sitka spruce aeroplane lumber. This is sufficient wood for over 30,000 ordinary planes.

The output figures do not in themselves indicate the magnitude of the undertaking necessary to produce this material. In the first place, it

must be remembered that wood for aeroplane construction must be of a special quality never before required in lumber specifications. It must be of the quality of a cabinet wood. The most important quality in aeroplane wood is straightness of grain on all four sides. Straight edge grained lumber can be produced easily by sawing parallel to the bark, but the prevailing tendency of trees to grow in more or less of a spiral form renders it difficult to secure lumber in which the fibres do not run diagonally across the flat grain faces. Very large amounts of perfectly clear sound lumber have had to be discarded on account of this spiral grain.

### Spruce Hard to Reach.

In the second place, the spruce forests of the provinces are situated chiefly in the Queen Charlotte Islands and on the Northern mainland coast, several hundred miles from established lumber operations. The timber was largely owned privately, and cutting rights had to be secured, logging machinery, mills and labour had to be moved to these remote parts, and transportation facilities for logs, lumber and supplies established.

In order to secure the aeroplane material with as little delay as possible, the logging had to be done on a selective basis, only the clear straight grained spruce logs being cut. This naturally reduced the camp output of logs; but it increased the production of aeroplane material, as no time was wasted on inferior spruce or on the other species of timber.

When the operations commenced there were on the Queen Charlotte Islands three small sawmills at Massett Inlet and on the mainland pulp at Ocean Falls and Swanson Bay and a small sawmill at Georgetown, near Prince Rupert. The sawmills on Massett Inlet were put into commission and two new mills built. New plants were also constructed at Prince Rupert and Skeena City. Approximately three thousand men were employed on the work in the northern spruce forests.

The mainland mills were supplied largely with logs from the Queen Charlotte Islands. In order to transport the logs across Hecate Straits it was necessary to make them up into compact Davis rafts.

The placing of all contracts for logs and lumber was handled by the Imperial Munitions Board, under Major Austin C. Taylor, Director of the Department of Aeronautical Supplies.. The inspection of the lumber was done by the Aeronautical Inspection Department of the Imperial Ministry of Munitions, under Roland C. Craig, District Inspector. Forty examiners were employed in this department, and every piece of lumber was carefully inspected before being stamped for shipment. The requirements for aeroplane lumber are rigid. On the average it was possible to secure a recovery only of 20 per cent. from the selected logs.

During the thirteen months that operations were conducted the output was increased from 100,000 feet per month to 6,500,000 feet per month, and if the war had continued an even larger supply would have been secured.

### Solid Trains of Lumber.

The lumber from the Queen Charlotte Islands and the northern mills was loaded on barges and towed to Prince Rupert, where the Grand Trunk Pacific Railway installed several cranes which transferred it to the cars. It was not an uncommon thing for solid trains of aeroplane lumber to be despatched from Prince Rupert. Owing to the urgency of the demand for this material it received preference over all other freight on both the railways and ships.

The Imperial authorities have tried all the known kinds of wood for aircraft and have found that Sitka spruce is far superior to any other. The quality of spruce growing in Northern British Columbia is undoubtedly the very best that can be secured. It is a well-established botanical fact that the farther north any plant can be grown successfully the better the quality, and this seems to be borne out in the case of Sitka spruce.

### No Large Supplies Left.

Though the survey of the forest resources made by Roland D. Craig for the Commission of Conservation shows the amount of Sitka spruce as being estimated at fourteen billion feet, only a small proportion of this is suitable for aircraft construction; and besides, a large proportion of the aggregate is so scattered and mixed with other species that it cannot be logged separately on a commercial basis. In the Queen Charlotte Islands, however, there are large areas where the spruce exceeds thirty-five per cent. of the stand, and it is from these forests that the bulk of the output has been secured. It is estimated that the continuation of the cutting on a war basis would have practically exhausted the supply which could be secured at a reasonable expense of money and effort.

In view of this fact an effort should be made to conserve the remaining supplies of this timber. It cannot be replaced in centuries and it is doubtful if the succeeding growth will ever attain the same quality as this virgin spruce.

### RANDOM

In Missouri the university forestry department is urging the farmers to raise walnut, which is much better than what the socialists in North Dakota are urging them to raise.

—American Lumberman.

## A CAMPAIGN WITHOUT AN ARMISTICE!

Nineteen years ago on January 15th, the Canadian Forestry Association was born. At the annual meeting in 1901 the total membership was 244 and the total receipts \$192.45.

On January 15th, 1919, the total membership is 8,000 and the total revenues \$15,270.56. Total expenditures for 1918 were \$14,340.65, leaving a balance for the 1919 campaigns of \$929.91.

The Canadian Forestry Association has been advancing rapidly, even under the heavy handicaps of wartime. Since 1914, the membership has increased from 2900 to 8000, and the total revenues have gone up about three hundred per cent.

It cannot be emphasized too frequently that the Association is not identified with any government or commercial interests. While supported in a limited measure, financially, by the Governments of the Dominion, Ontario, Quebec, and New Brunswick, and by grants from public-spirited lumber and paper companies, it pursues a course in which the public interest is the one and only consideration.

Features of our 1918 campaigns were as follows:

Our Railway Exhibition Car, travelling through scores of back settlements in the areas of greatest forest fire hazard. Motion picture lectures given at each stop. Demonstrations of modern fire prevention methods given by a series of exhibits aboard the car.

6000 educational booklets written for and distributed in Saskatchewan, 6000 in Alberta, and 3000 in Manitoba.

10,000 copies of "Petit Catechisme de la foret" a primer for children, distributed in Quebec settlements. 10,000 copies of "The Child's Forest Book" placed in Northern Ontario.

Three issues of 5000 each of "Le Bulletin des Forets" circulated to the clergy and rangers of Quebec.

Fully 60,000 school children reached by Forestry Association educational stories through the teachers.

12,000 copies of "The Forests of Canada in Peace and War," sent to legislators and other public leaders.

3000 copies of "The Case for Nova Scotia's Forests," and 5000 copies "Nova Scotia's Stake in Forest Protection" placed in Nova Scotia.

10,000 copies of "A Partnership Offer" circulated in New Brunswick and Nova Scotia.

Five lecturers appearing under the Forestry Association's auspices held 120 public meetings between Spring and Fall. Two of above were provided by the Quebec Government and one by the Dominion Government.

A weekly service of lantern slide cartoons was provided for practically every motion picture theatre in the forested districts of the Dominion.

Motion pictures were similarly utilized to good effect.

Five school lecture sets were kept continually circulating between Boards of Education and Churches, reaching thousands of people.

Two special campaigns conducted with the governments of Alberta and Nova Scotia to secure improved protection of forests.

A Publicity Bureau reaching hundreds of Canadian newspapers. A vast amount of space has been devoted to forestry matters by the Canadian press in 1918.

The above comprise some of the more important activities of your Association during the past year.

One of the paramount considerations in the advancement of forest conservation is the development of the membership. We trust you will not suffer your own membership to lapse, and that you will score a new recruit for us during 1919.

The Canadian Forestry Association is a vital element in Canadian democracy. It has no selfish ends to serve. It is the instrument of intelligent citizenship, seeking to bring about sane administration of the forest resources. No Government possibly can perform this work; no commercial body would care to undertake it.

The responsibility and privilege of serving the future Canada in this way belong to YOU. There is no such thing as handling it by proxy.

—o—

You have a dollar.  
I have a dollar.  
We swap.  
Now you have my dollar.  
And I have yours.  
We are not better off.  
You have an idea.  
I have an idea.  
We swap.  
Now you have two ideas.  
And I have two ideas.  
That's the difference.

—The Advertising News.

## FOR SALE—CHOICE TIMBER TRACTS

One or both; located on Columbia River and Tributaries north of Revelstoke, British Columbia; twice cruised by Marnick, Mitchell, Peat & Co., New York; surveyed by Christie & Danson, Vancouver, B.C.; near interior market; saving in freight over coast shipments two dollars thousand. Do you want high class timber property, if so write

S. A. HOLBROOK, Bradford, Pa., "Owner."

### TIMBER IN M. FEET

| TRACT             | CEDAR       | SPRUCE      | FIR        | PINE       | HEMLOCK     | TOTAL                    | CEDAR<br>POLES |
|-------------------|-------------|-------------|------------|------------|-------------|--------------------------|----------------|
| Downie Creek----- | 204,143,000 | 47,228,000  | 18,186,000 | 7,473,000  | 79,748,000  | 356,778,000              | 60,612         |
| 16 mile-----      | 54,002,000  | 30,687,000  | 2,433,000  | 1,778,000  | 21,612,000  | 109,892,000              | 21,625         |
| 25 mile-----      | 67,468,000  | 39,908,000  | 28,799,000 | 5,068,000  | 47,086,000  | 188,332,000              | 27,612         |
| Goldstream-----   | 33,649,000  | 16,406,000  | 478,000    | 200,000    | 7,577,000   | 58,310,000               | 8,857          |
| 50 mile-----      | 45,890,000  | 34,395,000  | 6,050,000  | 1,155,000  | 20,095,000  | 107,585,000              | 35,390         |
| Schoonmaker-----  | 2,785,000   | 10,851,000  | 1,348,000  |            | 4,108,000   | 19,090,000               | 2,116          |
| (83 miles)        | 407,936,000 | 179,475,000 | 57,294,000 | 15,654,000 | 179,629,000 | 839,988,000              | 156,212        |
|                   |             |             |            |            |             | Dead and down cedar----- | 25,217,900     |
|                   |             |             |            |            |             |                          | \$65,205,000   |

### S. A. HOLBROOK (Trustee) TRACTS.

| TRACT        | CEDAR       | SPRUCE      | FIR        | HEMLOCK    | TOTAL       | CEDAR<br>POLES |
|--------------|-------------|-------------|------------|------------|-------------|----------------|
| Gaffney----- | 57,433,000  | 35,534,000  | 15,653,000 | 10,168,000 | 122,197,000 | 81,062         |
| 22 mile----- | 60,880,000  | 67,425,000  | 28,951,000 | 74,131,000 | 239,622,000 | 32,569         |
| (34 miles)   | 118,313,000 | 102,959,000 | 44,604,000 | 84,299,000 | 361,619,000 | 113,631        |

## BRITAIN'S FORESTS AND NEW ENGLAND.

By E. C. Hirst, State Forester of New Hampshire.

Aroused by the exigencies of the war, Great Britain's reconstruction committee formulated a forest policy for the United Kingdom which was adopted before the armistice was signed and is now being organized. It provided for the requisition of land by the State for tree planting on a large scale, and by advances to private owners for tree planting on their own land on a profit sharing basis. By these means it is planned to build up home supplies of timber and the industries dependent on them. Can we learn a lesson from the experience of our ally?

It is certain that under the stimulus of war needs our pine mills have stripped over 35,000 acres in New England during the last two years, and probably over 100,000 have been cut over by all mills in the State. We can be proud of the fact that we were able so quickly to make available this large amount of New England lumber for the great cause which it served; but we must recognize the extent to which it has depleted our resources. To this end a broad policy should be worked out that will encourage the replanting of our cut over forest lands.

## FRANCE'S POWER OF RESISTANCE.

An American lumberman serving in France has written the following most interesting tribute to the Forests of France in a letter to a friend: "Over here the lumber business is good, especially the demand. If memory fails me not, in a conversation with you last winter, you mentioned that it was your understanding that they

expected the forestry troops to get out about 20,000,000 feet a month, and you wondered where they were to get the timber to cut that much. Last month we cut 45,000,000 feet and we have orders for 100,000,000 feet a month for several months. Besides the lumber cut last month we made over 300,000 ties, 50,000 cords

of wood, thousands of pieces of piling, poles and posts, and some miscellaneous products. We have asked for several thousand more troops which are expected over soon. We now have seventy-five mills running day and night, and before spring we expect to have 100 more and to be making 100,000,000 feet a month. As for the available timber, it is here. About two weeks ago Maj. Kelly, now Lieut.-Col. Kelly, formerly of the Booth-Kelly Lumber Co., Portland, Ore., and I made an automobile trip to the Spanish border. We went down the western coast of France and returned through central France, inspecting several operations on the way. We went up the Pyrenees Mountains on mules to look over a tract of timber and the chances for logging. There were 100,000,000 feet in the one tract, all around one ravine or pocket. About two-thirds of this was in France and one-third in Spain. It was practically all beech, but there was a sprinkling of fir in it. Another tract looked over a short time ago had 500,000,000 feet in it. We are just starting to saw a tract of 50,000,000 feet of white oak, so you can readily realize there is a lot of timber in France. Besides our operations, the British have several operations and of course the French have, too.

---

### TO REHABILITATE FRENCH FORESTS.

(Boston Transcript)

There is a fine sentiment in that gift of 3,000,000 pine seedlings that Pennsylvania is to send to France as a contribution toward the restoration of the war-riddled forests. This country is certainly indebted to the French nation for many things in connection with the war, not the least of which is the generosity with which she opened her highly prized forests that our armies might be supplied with the requisite timber for engineering works. Into those carefully tended woodlands our regiments of trained lumbermen moved, armed with all the up-to-date tools and machinery for the expeditious felling and sawing of the trees. Notwithstanding that this work was done under the guidance of French and American foresters and with as much regard for the future welfare of the forests as the circumstances would allow, the results must necessarily appear destructive to people so highly educated in the art of forest conservation.

Now that our forest regiments are to be withdrawn as rapidly as transport facilities will permit it will be the handsome thing for the United States to do what it can toward aiding in the

repair of the damage that was permitted in its interest. There will still remain a million or more acres in northern France from which the axes and the guns of the enemy stripped the once thrifty forests and in the restoration of which Germany and her henchmen should be made to toil. What France really would be glad to have from this country in this reclamation work is not seedling trees, however good, but seed. This country has just now closed its own doors against foreign-grown nursery stock of all kinds in fear of the pestilence that the plants may carry. It would not be strange, therefore, if France felt a similar reluctance to accept our trees, not in retaliation for our prohibition but because of a justifiable dread of the possible consequences.

Seed, however, is clean and will be much in demand. Not unnaturally, though, the French foresters have their preferences in the matter of species and strangely enough from our point of view white pine from eastern America is not by any means a popular tree with them, not merely because it is subject to the blister rust but because its lumber commands a lower price in the market than even Scotch pine, regarded as inferior here. The acceptancy of Pennsylvania's gift is only another evidence of the traditional courtesy of the French people, who unquestionably appreciate the spirit in which it is made. Seed of some of our choicest species such as Douglas fir from the west coast and red oak from the east would be most welcome in large quantities, and the American Forestry Association at Washington has afforded an opportunity for all in this country who wish to bear a hand in the effort to make good the unavoidable wreckage by creating a fund for the collection and shipment of the seed.

---

### G. A. GUTCHES TWICE PROMOTED.

G. A. Gutches, District Inspector of Forest Reserves (Dominion Forestry Branch) at Prince Albert, Sask., has received a substantial promotion by being appointed Superintendent of Government logging and sawmilling operations on Menominee Indian Reserve at Neopit, Wisconsin. Mr. Gutches will work under the immediate supervision of Mr. J. P. Kinney who is in charge, at Washington, of forestry work on Indian Reservations throughout the United States.

He was married on November 11th to Miss Alleen Arnel Erb, daughter of Mr. and Mrs. G. W. Erb, of Winnipeg. Mr. and Mrs. Gutches are now at home at Neopit, Wis.



**FOREST TELEPHONES**

Make the life of the forester better worth living. They relieve him from the appalling loneliness. They help him to keep in human voice touch with foresters miles away.

In emergencies—fire—sickness—hunger—the speed with which they can summon help is marvellous.

Write for full particulars of how to install the Northern Electric Forest Telephone System. Address the Office nearest you.

**Northern Electric Company**  
LIMITED

|          |          |           |
|----------|----------|-----------|
| Montreal | Toronto  | Regina    |
| Halifax  | London   | Calgary   |
| Ottawa   | Winnipeg | Vancouver |

***Northern · Electric · Forest · Telephones ·***

# THE UNIVERSITY of TORONTO

AND

## UNIVERSITY COLLEGE

WITH WHICH ARE FEDERATED

ST. MICHAEL'S, TRINITY and VICTORIA COLLEGES

Faculties of

ARTS  
EDUCATION

APPLIED SCIENCE  
MUSIC

MEDICINE  
FORESTRY

Departments of

HOUSEHOLD SCIENCE

SOCIAL SERVICE

For information, apply to the Registrar of the University, or the Secretaries of the respective Faculties.

## GUARDING THE MIGRATORY BIRDS.

The Dominion Parks Branch of the Department of the Interior has furnished the following data as to the aims and purposes of the Migratory Birds Convention Act, and as to the habits of the birds protected by the Act.

Last year a treaty between Canada and the United States for the protection of useful or harmless migratory birds, the first international treaty ever made in the interests of wild life conservation, was signed at Washington. Those seeking a solution of the problem of the protection of bird life on the continent of North America have for a long time realized that their object would best be reached by international treaty. As long as the matter was left in the hands of the various provinces and states of the two countries, birds protected in one part of the continent might be exposed to destruction, owing to the lack of protective laws, when they migrated to another part.

The Act passed by the Dominion Parliament sanctioning the treaty and providing legislation for its enforcement is known as the Migratory Birds Convention Act. It seems desirable to furnish the public with further information as to its objects. The general public should cooperate with game officers and peace officers to facilitate the strict carrying out of the regulations of the Act. The protection of bird life is of supreme importance.

### Birds That Are Useful.

Insectivorous birds render a magnificent service by consuming insect species which if unchecked would soon multiply to vast hordes that would utterly destroy the forests and devastate the crops. Migratory game birds are of great value as a source of food and beneficial outdoor sport. In addition to their practical service, many birds are very important from esthetic point of view. The handsome plumage and vocal ability of many species add greatly to the beauty of nature and to the pleasure of the outdoors, and even the unmelodious and plain birds help to give character and animation to the open-air world. So much a part of our lives have the familiar birds grown that without them the world would seem to have lost much of its colour, light and interest. The uniform system of protection provided by the Act is a great step toward their preservation and encouragement, and the Act should have the enthusiastic support of every right-thinking citizen.

The economic service rendered by insectivorous migratory birds cannot be overestimated. There are few of us who fully appreciate this service. The fecundity of insect life is almost beyond belief, and tree and plant life in every stage of growth from the seed to maturity, is attacked by myriads of larvae and full-grown insects. If it were not for their persistent enemies, the birds, which devour vast numbers of eggs, larvae and perfect insects, the ravenous insect multitudes would spread desolation throughout the woods and fields. Without the constant help of the birds it would be impossible to protect crops and forests from the innumerable worms, caterpillars, beetles, borers, plant lice and larvae. The forests would not be long in existence but for the unceasing industry of the birds in the pursuit of insects, and protecting and encouraging the birds, and if possible increasing their numbers, is the most practical step that can be taken toward the preservation of the timberlands. All who appreciate the enormous value of the forests will realize the vast importance of bird protection.

For the protection of our forest trees we are particularly indebted to woodpeckers, nut-hatches, creepers, titmice and warblers. There is hardly a crevice in the bark or a single leaf or stem that is overlooked by these birds in their tireless search for insect food, and every foot of ground and litter underneath the trees is minutely examined by the birds for hidden insects. It is of great interest that, to increase their efficiency, nature has assigned different work to the different species according to their habits and equipment, so that while some species with special organization for their tasks, pursue their prey on the trunks and larger limbs, others equipped for their particular work, hunt among the smaller branches and foliage.

In the past farmers and orchardists, as well as those to whom the smallest bird or animal is game, have destroyed large numbers of useful or harmless birds. The farmers and fruit growers did so under the impression that they were protecting their crops or fruit from the birds. Birds sometimes injure the crops of the farmer who in improving his land has cleared away the wild berry bushes and seed-bearing weeds, which provide the natural food of the birds, forcing them to feed upon the cultivated grain or fruit. But the little harm done by the birds, is infinitesimal, when compared with the

Peterborough Canvas Covered and Wooden Canoes are built in all sizes and for all purposes. For Pleasure, Cruising, Trapping or Freighting.

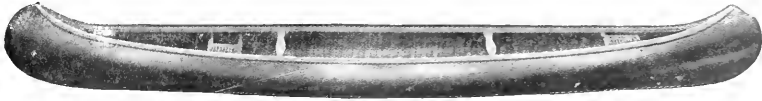

Peterborough Motor Boats, like the Canoes, are built in all sizes and for all purposes. If you are interested we will send you our illustrated Catalogue.

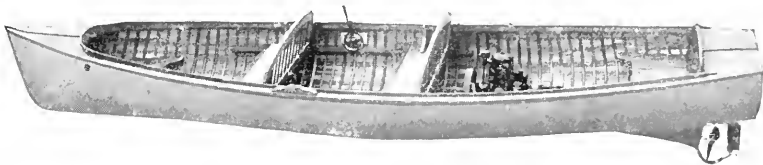

This Trade Mark appears on all genuine Peterborough Craft.

## THE PETERBOROUGH CANOE CO. LIMITED

Peterborough, Ontario, Canada

# FORESTERS!

We want you to know  
all about our

## “ARCTIC EIDERDOWN SLEEPING ROBES”

It is to your own personal interest and  
comfort to own an Arctic Robe.

—Manufactured only by—

**WOODS MFG. CO. LIMITED**  
**OTTAWA**

“Booklets Ready for Mailing.”



good they do. The aim of the Act, of course, is to protect the birds not only from those to whom all wild life is game, but from the farmer who owing to lack of knowledge of the habits of the birds, supposes that in killing them he is getting rid of pests.

### Birds as Crop Savers.

Abundant evidence that cannot be questioned, to show the value of birds as crop savers, is available. Examination of bird stomachs by biologists of the United States Department of Agriculture showed that insects made up 100 per cent of the summer food of four common species of swallows, 100 per cent of the night-hawk's food, 98 per cent of the phoebe's, 94 per cent of that of the Baltimore Oriole, 98 per cent of the huse wren's, 80 per cent of the common crow's, 80 per cent of the kingbird's, 74 per cent of the meadowlark's, 68 per cent of the black-capped chickadee's, 80 per cent of that of four common species of woodpecker, 64 per cent of the brown thrasher's, 68 per cent of the bluebird's, 42 per cent of the robin's, and from one-half to one-third of the food of many other familiar species. This data was obtained from the examination of from over one thousand to not less than several hundred stomachs of each species. In winter, when insects disappear, many of the birds that remain during the cold weather consume large quantities of weed seeds, thus lessening the growth of noxious weeds during the following summer.

Mosquitos, flies, and others insects spread disease. The mosquito would be a much greater pest than it is but for nighthawks, whippoorwills, swallows, swifts, and flycatchers, which devour myriads of these troublesome insects. Ducks

and other birds that inhabit ponds, lakes, and marshes consume enormous numbers of mosquito larvae. Flies are eaten by almost all species of birds.

### Even Hawks and Crows.

Rats and field mice are a source of considerable damage to crops and stored grain, and frequently injure fruit trees by gnawing the bark from trunk and larger roots. Hawks, owls, and crows render a useful service by preying upon these rodents.

The Act establishes a continuous close season on the following migratory insectivorous birds: bobolinks, catbirds, chickadees, cuckoos, flickers, flycatchers, grosbeaks, humming birds, kinglets, martins, meadowlarks, nighthawks, nuthatches, orioles, robins, shrikes, swallows, swifts, tanagers, titmice, thrushes, vireos, warblers, waxwings, whippoorwills, woodpeckers and wrens, and all other perching birds which feed entirely or chiefly on insects. The Act provides that the close season on other migratory non-game birds shall continue throughout the year, except that Eskimos and Indians may take at any season auks, auklets, guillemots, murre, and puffins, and their eggs for food and their skins for clothing. Migratory game birds included in the terms of the Act are waterfowl, including brant, wild ducks, geese, and swans; cranes, including little brown, sandhill, and whooping cranes; rails, including coots, gallinules, sora, and other rails; shorebirds, including avocets, curlew, dowitchers, godwits, knots, oyster catchers, phalaropes, plovers, sandpipers, snipe, stilts, surf birds, turnstones, willet, woodcock, and yellow-legs; and pigeons, including doves and wild pigeons.

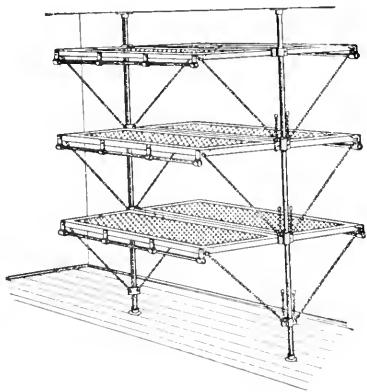

## STEEL BUNKS FOR CAMPS

Included in the well-known line of DENNISTEEL factory, hospital, camp and ship equipment is the all-steel sanitary bunk illustrated. Take up very little room, are comfortable, hygienic and practically indestructible—a permanent investment. Write for particulars and folders on any of the following lines: Steel Lockers, Bins, Cabinets, Chairs, Stools, Etc. Standardized Steel Shelving (knock-down system), Steel Hospital Equipment, General Builders' Iron-work, Ornamental Bronze, Iron and Wirework. Wirework of every description.

THE DENNIS WIRE AND IRON  
WORKS CO. LIMITED

LONDON  
CANADA

HALIFAX MONTREAL OTTAWA TORONTO  
WINNIPEG VANCOUVER

The Act provides that there shall be for the following migratory game birds: bandtailed next ten years a continuous close season on the pigeons, little brown, sandhill and whooping cranes, swans, curlew and all shorebirds (except the black-breasted and golden plover, Wilson or jack snipe woodcock and the greater and lesser yellowlegs), provided that during such ten years the close season on cranes, swans and curlew in the province of British Columbia shall be made by the proper authorities of that province within

the general dates and limitations prescribed in the Act for the respective groups to which these birds belong.

Migratory non-game birds specified by the Act are: auks, aukets, bitterns, fumars, gannets, grebes, guillemots, gulls, herons, jaegers, loons, murre, petrels, puffins, shearwaters, and terns.

The taking of nests or eggs of any migratory bird, except under permit for scientific or propagating purposes, is prohibited.

### ZEPPS. FOR FOREST SURVEYS.

The Forestry Journal aims to achieve a new standard of interest and value in its 1919 contents. An article by Flight Commander Barron, on the advantages of lighter-than-air machines—improved “Zeppelins”—in surveys and similar work will make bright reading.

Other special articles in the February number are from the pen of Sir John Stirling-Maxwell, of Glasgow; Hon. E. A. Smith, Minister of Lands, New Brunswick; and Dr. C. D. Howe of Toronto University Forest School.

Plenty of good illustrations, and a well-printed publication.

# Lumbermen

Here is something you need. An AXE and HAMMER combined. The poll or head of Axe is made of the highest grade of octagon cast steel, inserted and welded as shown. It is then properly tempered and will stand heavy driving and rough use of any kind.

Eastern lumbermen are using this Axe entirely for chopping and driving Tree Wedges. Write us for prices and further particulars.

## Campbell Bros.

ST. JOHN, N.B.

SOLE MAKERS

XXX Chopper and Edge Tools.



Patented July 1915.

**TREES, SHRUBS and SEEDS**

Hardy Northern Trees and Shrubs at Lowest Prices. Native and Foreign Tree Seeds.

**EDYE-DE-HURST & SON, DENNYHURST**

Shippers to H.M. Government, Etc.  
DRYDEN, ONT. Correspondence Francaise.

**Hill's Seedlings & Transplants**

ALSO Tree Seeds for Reforesting. Best for over half a century. Immense stock of leading hardy sorts at low prices. Write for price list and mention this magazine. Forest Planters Guide Free.

**The D. HILL NURSERY CO.** Evergreen Specialists  
Largest Growers in America.  
Box 503. DUNDEE, Ill., U.S.A.

**Try This Stump Puller at Our Risk**

The Smith Stump Puller will take out every tree and stump by the roots, clearing from one to three acres a day, doing the work of twenty men. We want you to send for our 3 year guarantee against breakage and our free trial proposition. Address  
**W. Smith Grubber Co.**  
11 Smith St.  
LaCrescent, Minn.

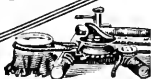
**GAGNON & MORISSETTE**

TIMBERLAND CRUISERS  
LUMBER CONTRACTORS  
FOREST INDUSTRIES

CHICOUTIMI, - - P.Q.

**LT.-COL. L. J. D. MARQUIS**

Forest Engineer and Mem. Can. Soc. of F.E.;  
Quebec Assoc. of F.E.; Former  
Mem. Que. F. Service

Timber Factors and Logging Costs  
Facts on Forest Growth and Future Products  
Forest Cruising and Mapping  
90 LOCKWELL AVENUE - - QUEBEC

**Timber Lands Bought & Sold**

Timber and Pulp Wood Estimates.

**R. R. BRADLEY**

CONSULTING FORESTER  
Globe-Atlantic Bldg. - ST. JOHN. N.B.

ASK



FOR

**Timber Estimating & Mapping**

Management of Forest Properties.  
Supervision of Lumbering Operations.  
Forest Planting.

**COOLIDGE & CARLISLE**

FOREST ENGINEERS  
BANGOR - - - - MAINE.

**Timber Estimates**

JAMES W. SEWALL

Old Town, Maine.



*Lake Helena, at foot of Mt. Robson, British Columbia. Shoulder of Mt. Robson on right.*

The Canadian Forestry Journal is usually liked by outdoors people. You can send it to a friend for an entire year for a dollar bill.

Ontario employed more than 1000 rangers in 1918 at a cost of about \$500,000. Ontario has seventy million acres of forest land to guard against waste by fire.

Canada has the third largest forest supply in the world, Russia ranking first and the United States second.

### THE EASY ROAD.

Some people like the prairie state  
 Without a hump or hollow,  
 With just a highway long an' straight  
 Across the world to follow,  
 With never not a hill to climb  
 Nor timber go a'trailin'—  
 With never nothin' all the time  
 But plain an' easy sailin'.

Up here the country's rather rough,  
 The roads are few an' narrow;  
 A man has got to be as tough  
 An' nimble as a sparrow.  
 There's rocks an' stones along the way  
 An' rivers to git over;  
 You see more thistles ev'ry day  
 Than ever any clover.

The roads of life are like the roads  
 Of earth, the way they vary;  
 An' some of us have got the loads,  
 An' some have none to carry.  
 Some thorofares are tempest-torn  
 An' others built of gravel—  
 For some to rocky roads are born,  
 An' some the smooth to travel.

The prairie road is level, wide,  
 An' mighty easy goin',  
 With painted signs on either side,  
 An' roses by it growin'.  
 The prairie highway hain't a tree  
 Or rock your courage testin';  
 An easy highway it must be—  
 An' darned uninterestin'.

DOUGLAS MALLOCH,  
 the "Lumberman's Poet."

## 7999 AND YOU

The Canadian Forestry Association is a union of progressive Canadians concerned in the preservation and proper utilization of the forest resources. The motive of national welfare predominates inasmuch as an overwhelming majority of the membership has not a penny of selfish interest in timber limits or wood-using industries. Conservation, as this Association has frequently emphasized, is Community Business. He who pretends to an interest in social advancement cannot well consent to the undermining of the material foundations beneath our national existence.

There are now 8000 Canadians within the membership of this Association. A clear addition of two thousand was obtained in 1918, largely through the loyalty of those who sought out recruits in their own neighborhoods.

Considering the hampering influences of war, the Association is making progress. The advance from 2900 members in 1914 to 8000 members in 1918 surely promises a splendid increase in days when the public mind is unclouded by the horrors of battle.

This month each member will receive two missives, one summing up what we have achieved in 1918, another giving the members a better perspective of their personal responsibility and privilege in a national cause which can be fought by the masses of people and by them alone.

Read both of these documents. They are brief and becomingly illustrated.

Then when the Association's memorandum of the dollar fee comes along (covering subscription to the Journal as well), you will probably feel fully content to stand by us through 1919.

Notice the improvement in this issue of the Forestry Journal—fine paper, fine illustrations, better articles. This will be improved upon exactly as the members manifest their loyalty by prompt payment of the small annual fee.

Our advertising revenue does not meet one-eighth of the cost of issuing this Journal. Our paper bill alone is more than \$2200 annually, and when the price of engravnigs, printing, etc., is added to that, it will be found that the dollar fee does very little more than pay the cost of mechanical production.



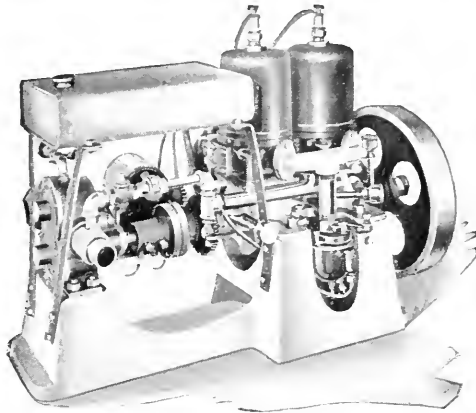

## FAIRBANKS-MORSE FIRE FIGHTING ENGINES

These compact powerful little pumping outfits have repeatedly substantiated our claims during the past year, all over Canada. They can be readily transported wherever man or pack horse can go. Governments and Private Owners of Forests everywhere, can materially reduce their fire losses by the use of these outfits.

Full information and prices on request.

**THE CANADIAN FAIRBANKS-MORSE CO.**  
LIMITED

**MONTREAL - OTTAWA**

ST. JOHN. QUEBEC. TORONTO. HAMILTON. WINDSOR.  
WINNIPEG. SASKATOON. CALGARY. VANCOUVER. VICTORIA.

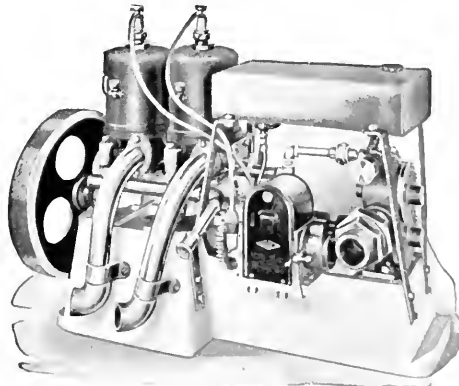

**CONFEDERATION LIFE**  
ASSOCIATION

**UNCONDITIONAL  
ACCUMULATION  
POLICIES**

Are liberal up-to-date contracts which guarantee to the insured every benefit consistent with safety.

**WRITE FOR PARTICULARS**

which will gladly be furnished by any representative of the company or the

**HEAD OFFICE,  
TORONTO**



**QUEEN'S**  
UNIVERSITY

KINGSTON  
ONTARIO

**ARTS MEDICINE  
EDUCATION  
APPLIED SCIENCE**

Mining, Chemical, Civil, Mechanical and  
Electrical Engineering.

**HOME STUDY**

Arts Course by correspondence. Degree with  
one year's attendance.

**SUMMER SCHOOL**

JULY AND AUGUST

**NAVIGATION SCHOOL**

DECEMBER TO APRIL

GEO. Y. CHOWN, *Registrar.*

**R. O. SWEEZEY**

(B.Sc., M.E.I.C.)

WATER POWERS. TIMBER LANDS.

**FINANCING**

164 St. James Street - MONTREAL.

**UNIVERSITY OF  
NEW BRUNSWICK**

FREDERICTON, N.B.

**DEPARTMENT OF FORESTRY**

Established in 1908.

Best of facilities for definite instruction and supervision in Practical Forestry.

Surveying, cruising and construction work carried on in our own tract of 3600 acres, with Forestry Camp in the centre.

Competent men from the School at present in demand to take up Forest Survey work with the Provincial Crown Land Department.

For further information address:

**DEPARTMENT OF FORESTRY**

University Calendar furnished on application.

C. C. JONES, *Chancellor*

**P. L. BUTTRICK**

CONSULTING FORESTER

**NEW HAVEN, CONN., U. S. A.**

P.O. BOX 607

**TIMBER ESTIMATES  
UTILIZATION STUDIES  
PLANTING PLANS**

Landscape and General Forestry Work.  
Eight years experience in practical  
forestry work of all sorts.

# Forest Protection Conference

WINDSOR HOTEL, MONTREAL,  
WEDNESDAY AND THURSDAY,  
JANUARY 29TH AND 30TH.

---

Continuing the series of successful public meetings of previous years, a Forest Protection Conference will be held at the Windsor Hotel, Montreal, commencing Wednesday morning, January 29th, and continuing until Thursday evening, under the auspices of the Quebec Forest Protective Association which includes the St. Maurice, Laurentian, and Southern St. Lawrence Forest Protective Associations.

The Canadian Forestry Association, co-operating with the foregoing, is organizing a public meeting for Wednesday afternoon, January 29th, at which such speakers as F. J. Campbell, President Canadian Pulp & Paper Association; W. G. Power, President Canadian Lumbermen's Association; Brig.-Gen. J. B. White; Major Barrington Moore (New York); and Hon. W. R. Brown, will discuss subjects of popular interest.

At the Thursday session of the Quebec Forest Protective Association, Lieut. Lewis will describe Aerial Photography.

"Lumbering in Scotland" will prove a most interesting address from Mr. E. C. Hirst, State Forester of New Hampshire, who recently returned from Overseas.

Mr. J. W. Swaine, who has charge of forest insect investigations for the Department of Agriculture, will tell of the importance of slash disposal in affording protection from insects.

There will also be a talk on the use of tractors in woods operations, and an address on aeroplane work in forest protection.

Meetings of the Woodlands Section of the Canadian Pulp and Paper Association, and the Canadian Society of Forest Engineers, have also been arranged.

New Motion Pictures will be shown.

The meetings last year were splendidly attended. This year's programmes will hold your attention every minute.

Keep the dates open and come along!

---

WEDNESDAY AND THURSDAY  
JANUARY 29th AND 30th, 1919.

## TO POOL IDEAS FOR FIRE PROTECTION BETTERMENTS.

An excellent suggestion for the pooling of helpful ideas in connection with many branches of forest protection work was made at the last meeting of the forest protective associations in Montreal and during December was put into effect by the forming of a special committee with Mr. J. B. Harkin, Commissioner of Dominion Parks as Chairman, and H. C. Johnson of the Board of Railway Commissioners as Secretary. This committee will be widely representative of the government and private forest protective systems and of the Commission of Conservation, Canadian Forestry Association and other bodies having an interest in this work.

It has long been realized that no clearing house facilities existed whereby individuals having constructive suggestions or with the results of actual experiments, can co-operate and advise with other individuals or organizations engaged in forest guarding. This applies not only to the field of mechanical appliances, etc., but forest protection publicity. The need of this auxiliary channel has been felt by many of those having to do with the practical end of forest protection during the past several years. Meetings will be held periodically and it is anticipated that much advantage to fire prevention efforts throughout the Dominion will result.



*Little Yoho  
Valley Falls,  
Yoho Park, B.C.*

IF YOU WANT A CHEW  
THAT WILL JUST SUIT

YOU ASK FOR

**STAG**

**CHEWING TOBACCO**

RICH AND SATISFYING.

IT IS ALSO KNOWN TO BE  
"EVER-LASTING-LY GOOD"



If you are interested in Forest Fire Protection or in the advancement of the Lumber and Pulp Industry by improved methods of communication, we shall be pleased to send you our booklet

“MARCONI WIRELESS IN CANADIAN FORESTS”  
with any additional information you require concerning

**Marconi**

“MADE IN CANADA”

# Wireless Apparatus

Installations designed to work from battery or other supply of any voltage—portable and air-craft sets—low and high power land stations. Outfits suitable for forest duty—strongly built and simple in operation.

THE MARCONI WIRELESS TELEGRAPH COMPANY  
OF CANADA, LIMITED

Contractors to H. M. Government.

*Head Office and Works:*

173 WILLIAM STREET, MONTREAL, P.Q.

Telegrams:  
“ARCON MONTREAL”

Telephone  
MAIN 8144

*Branch Offices at:*

VANCOUVER    TORONTO    HALIFAX    ST. JOHNS, NEWFOUNDLAND



Canadian Forestry Journal  
February 1919

FACULTY OF FORESTRY

MAR 6 1919

UNIVERSITY OF TORONTO



## THE PROFIT GOES TO THE NATION.

This magazine has no shareholders and pays no dividends. The total income from subscriptions, after paying for cost of publication, is applied to our national educational campaigns in forest conservation. Most facts are dry, but these are drier than usual: The bill for raw paper each issue exceeds \$200. A year's publication costs \$4,500, without counting a dollar for editorial expense, office rent, etc. The magazine belong absolutely to the membership.

The money must come from membership fees. When a member postpones payment of his dollar, he unconsciously deducts ten cents from its value, for each set of 'repeat' accounts sent out means an added and really needless expense. Co-operation is the spirit of the day.





# Canadian Forestry Journal

VOL. XIV.

OTTAWA, CANADA, FEBRUARY, 1919.

No. 2



Logging karrri in Western Australia. This timber occasionally produces 300,000 feet b.m. per acre.

## AUSTRALIA STEALS A MARCH ON CANADA

By H. R. MacMillan, Assistant to Director of Aeronautical Supplies, Vancouver;  
Former Timber Trade Commissioner for Canada.



Remarkable New Legislation Gives the State  
Thorough Mastery of Forest Properties—  
Public Interest Triumphs.



A few Canadians may have observed the strenuous propaganda that has been conducted during the past four years in Australia for the improvement of state forest administration.

The programme, which was initiated by Messrs. Jolly, then state forester for Queensland, who had had the benefit of Oxford training, Hoy, the chairman of the New South Wales Forest Commission, and McKay, State Forester of Victoria, has received great impetus from the efforts of the West Australia Conservator of Forests, Lane Poole, who brought to West Australia in 1916, the benefits of training at Nancy, followed by ten years administrative experience in South Africa and Sierra Leone.

Canadians who are interested in forestry would find much of profit and interest in the

publications now issuing from the forest departments and forest associations of the Australian States.

### Virgin Forests Fire-Killed.

It may astonish some of us in this country to realize that the timber industry of the State of Western Australia has been of greater relative importance to the inhabitants of that state than is the case in any Canadian province. One generation of development and settlement, accompanied by fire, has produced the same forest effect in Australia as in Canada. The forests of this State, the population of which is 300,000, which since settlement have produced timber to the estimated value of \$127,000,000, are now stated by the president of the newly-formed forest league to be good for only twenty years.

The forest area is small, permeated and surrounded by settlement, and but little opportunity exists to under-estimate the area or quantity of timber.

Such forest legislation as has existed in Western Australia has, as in Canada, been written by and for the most conspicuously and actively interested partner, the lumbermen or saw-millers, as they are known in that part of the world, the settlers, and the timber hewers unions. We in Canada know the former but not the latter.

The most important woods of West Australia have long been a staple article of export as railroad sleepers, particularly to Africa, and India, because of their resistance to decay and white ants. The hewing of these sleepers has at all times been a ready meal ticket for the Australian bushman, or timber hewer, and jealously guarded by his union.

#### Cheap Stumpage Here.

In a land where the settler could homestead at will, where 653,000 acres of the best timber was leased to operators at a total rental of \$3,500 annually, and where hewers could hew ties at will through the remaining public timber, on payment of nominal royalty only, there appears need of a new forest act.

Such an act, framed by Lane Poole, after three years study of the problem, has now been passed by the Legislature.

The West Australia Forest Act presents several striking features.

The Forest Department is removed from the Department of Lands to the Department of Mines, on the theory that the Minister in charge of lands will be under constant temptation to make lands available and will shirk from creating permanent forest reserves, whereas the Minister of Mines, having no specific interest in land administration, will act unrestrainedly on the advice of the Conservator of Forests.

#### Conservator's Power Absolute.

The Conservator of Forests is placed in office for seven years, removable only by a vote only of both the lower and upper chambers of the legislature. He is given all powers of a commissioner over all West Australia forests, now estimated at 3,000,000 acres, of which 1,300,000 acres have been cut over and 1,500,000 acres are under lease.

The Conservator is furnished with a definite source of revenue, without the necessity of each year going before the legislature, in that one half the forest revenue is each year set aside for



Blue Gum Forest in Australia ruined by fires occasioned chiefly by settlers.

forest work under his direction. This will amount to about \$135,000 annually, as compared with about \$60,000 expended in 1914-15.

As the programme develops, it is anticipated that additional funds will be provided. The principle adopted in Western Australia is worthy of consideration in certain Canadian provinces.

#### Working Plans for Reserves.

It is further provided in the Forest Act that the Conservator shall examine the forest lands of the State and set aside as permanent reserves those lands most fitted for this purpose. It appears to be the intention of the Act to extinguish or control any prior leases over such areas. The Act requires that working plans are to be prepared for the reserves, the working plans, after acceptance by the Cabinet, to have the force of law for ten years.

The sleeper hewers are to be abolished from the state forests on account of their wasteful operating methods.

An important part of the contemplated work specified in the Act is the regeneration by protection and silvicultural operations, of the damaged forest areas. It is further enacted that soft

wood plantations shall be established with the object of growing at home the \$400,000 worth of coniferous timbers imported into West Australia annually.

The Conservator is given power to build the necessary trained organization to carry out the provisions of the Act, and to establish a scheme, if necessary, to develop the field employees.

### Remarkable Planting Profits.

In this connection certain coniferous plantations in Australia have shown phenomenal results. *Pinus insignis* in particular at 25 to 30 years of age has reached an average annual growth of 2,400 to 2,800 feet board measure per acre. This in a country where common box lumber is in great demand in normal times at \$30.00 per thousand, allows an ample return from forest planting.

The efforts of Mr. Lane Poole will be watched with interest throughout Australia. He has succeeded in developing a more active public support and entrenching himself in a stronger position than has yet been reached by any Forest Service in Canada. He has also accepted heavier responsibilities. He has the advantage of working in very close contact with his public, as is possible in a small community.

### CEDAR FOR PAPER MAKING.

Editor Forestry Journal:—

Is it true that cedar is being used in pulp manufacture in Canada?

One large British Columbia pulp and paper company now uses a large proportion of western cedar in their kraft pulp. The product is said to be highly satisfactory from every point of view.

### THE "PEPTIMIST."

An Optimist is one who hopes; a pessimist one who doubts, and a "peptimist" one who gets. That is what a recent shingle conference was told during a talk on "pepticism" by the sales manager of a raisin company which suggests the desirability of unfolding outside talent occasionally at a lumber convention. The new word is sufficiently valuable to be retained, especially in the lumber industry, which always had a good deal of the quality which it stands for.—"American Lumbermen."



The famous Canadian "pointers" with their lumberjack crews on an upstream trip.

## THE OWNERSHIP OF OVERHANGING TREES.

A man has no right to any portion of a tree or the fruit thereof that may overhang his property, while growing on a neighbor's land.

Such is the interesting verdict reported by the Royal English Arboricultural Society as follows:

"A case dealing with this point came before His Honour Judge Parry, at Maidstone on November 13 last. The plaintiff had several apple trees growing on his land about 8 feet from the boundary. The branches of these trees overhung the land of the defendant. The defendant picked the apples off the branches and sold them. The plaintiff brought an action for wrongful conversion, and was awarded £10

damages. The contention on the part of the defendant was that, as he had the right to lop the branches of the trees which overhung his land, he had the right to pick the apples.

His Honour said (*inter alia*) the defendant's right to lop could not be contested, assuming that it was done in a reasonable way, in accordance with the custom of fruit farmers, at a proper season, and without unnecessary injury to the tree. When the branches were severed, however, that did not give the defendant any property in them or in the fruit on them. In law the branches or fruit, which formerly savoured of real property, had then by severance become personal property, but the property remained in the owner of the tree."

## EFFECT OF TREES ON RAINFALL

Those who read Dr. Fernow's interesting statement in the December Forestry Journal on "Do Forests Affect Rainfall?" will peruse the following opinion issued by the New South Wales Forestry Commission in a recent bulletin:

The effect which forests have upon the total annual rainfall is much disputed. For the present it is sufficient to state that, though careful French investigations extending over many years appear to indicate that forests cause a considerable increase in the rainfall, irrespective of the direction from which the rain-bearing winds may come, the principle has not yet been proved to the satisfaction of all concerned, while in Australia the question has not received adequate attention. If there be any effect of this nature, it does not necessarily follow that the quantity of rain reaching the soil of a forest is greater than would have been received if the soil had remained bare, for a considerable percentage of the rainfall is intercepted by the crowns of the trees, and, being spread over a very large surface, is evaporated before it can reach the ground; consequently, for the present no importance need be attached to this question from the point of view of the welfare of the forest itself.

The total annual rainfall is, however, of less importance to a forest than the distribution of rain throughout the year; but, unfortunately, in this connection also Australia lacks accurate data showing the effect of the forest. French observations show that forests cause a more

equable distribution, and it may be stated for what it is worth that popular opinion in the Atherton district of North Queensland, where comparatively large clearings of dense forests have been made during the last twenty years, is that the gentle "scrub" drizzle is now far less frequent than formerly. Such an alteration must undoubtedly be unfavourable from the standpoint of the forest, for young seedling growth, which benefits greatly from light showery and cloudy weather, is adversely affected by periods of hot sunny weather following upon storms.

Although the effect of the forest on rainfall is uncertain, accurate observations made have shown conclusively that forests have a local influence on the temperature of the soil and on the temperature and moisture contents of the atmosphere adjoining. The forest moderates the extremes of heat, in that the temperature of the forest soil and air is lower during the day and higher during the night than that of grass land adjoining. Also the humidity of the air in and over a forest is greater than that of air over open country, thus reducing slightly the evaporation of moisture, though neither this nor the former influence can be considered of very great importance. Of far greater moment are the screening effect of the forest cover in lessening radiation of heat and thus reducing frost danger, and in protecting the soil from the heat of the sun and the drying influence of strong winds, thus greatly reducing the loss by evaporation of moisture in the surface soil.



CLOTHING THE PRAIRIE WITH TREE LIFE.  
A photograph taken in 1918 by H. C. Weaver, near Atlas, Saskatchewan. The first trees were planted along the roadway in 1903.

## THE RURAL SCHOOL PLANTATION

By H. C. Weaver, Atlas, Sask.

The Rural School is first and foremost of all institutions, entitled to be the one spot where good cheer and social betterment reign supreme. If we just wander back in thought to the years of our childhood, we will remember the stately elm or maple, greeting us along our pathway to and from the rural school, and usually on the school-ground also, of the old district back east.

Let us be inspired to beautify our homes, our school grounds, and our public highways here in these prolific prairie provinces, and by the help of Nature, make use of the several hardy varieties of forest trees which are a proven success for planting in these none too humid western communities.

By hardy varieties, I refer, under average prairie conditions, to Red Willow, Manitoba Maple, Green Ash, and for a hedge, Caragana. These varieties, in the order in which they are named, make an ideal four-row plantation, for, I should say, three sides of the rural school grounds, having the Caragana planted next the building, one foot apart in the row, the other varieties four or five feet apart in the row, and all rows four feet apart.

This will permit of easy cultivation, it being assumed that no trees are planted until the land has been carefully worked for at least two years previous to planting and worked up so thoroughly that not a vestige of grass or perennial growth is alive. Experience has shown that no trees should be planted closer than ten or fifteen feet from the native sod. This strip between the trees and sod kept so cultivated as not to allow any growth whatever, and particularly, always keeping a deep furrow next the grass and thrown in toward the trees. This prevents the grass from working into the trees, as trees and grass will not thrive together on the prairies.

If not larger than two or three foot specimens of the above-mentioned varieties are planted not too soon before the rainy season begins in the spring, by tramping the soil down solid around the roots, and leaving a loose and level mulch on top, there is no reason why our efforts should not be crowned with success.

Of course there are occasional insect pests, but these need hardly be mentioned here, for if we will plant trees on these bald prairies, and thereby encourage the birds to make their homes among us, the insect pests will, by these "police-men of the air," be reduced to a minimum.

### 1919 OFFICERS, CANADIAN FORESTRY ASSOCIATION.

At the annual meeting of the Canadian Forestry Association in Montreal on Wednesday, January 29th, Mr. J. S. Gillies, of Gillies Bros., Braeside, Ontario, was elected President for 1919; Mr. Clyde Leavitt, Vice-President; Mr. Percy B. Wilson, of the Spanish River Pulp & Paper Mills, Sault Ste. Marie, a new director, and Hon. E. A. Smith, territorial Vice-President for New Brunswick.

### OFFICERS, WOODLANDS SECTION.

At the annual meeting in Montreal, Thursday, January 30th, of the Woodlands Section of the Canadian Pulp and Paper Association, the following officers were elected: Chairman, Robert P. Kernan, Quebec; vice-chairman, Marshall P. Small, Grand'mere; councillors, R. F. Kenny, Buckingham; A. J. Price, Quebec, and Ellwood Wilson, Grand'mere.

# AN IMPERIAL FOREST POLICY

By Sir John Stirling Maxwell,  
Glasgow, Scotland.



## Give Canadian Woods an Equal Chance by Taxing Baltic Imports—British Financial Aid for Forest Protection?



Foresight is not the strong point of democracy. Few statesmen look beyond their own generation, many not beyond the next election. Those who do have to face the enmity of the party machine, which in the Old Country and no doubt also in Canada is a machine devoted to the capture of votes. Forestry, which demands long views and offers no immediate benefit to the electors, has thus suffered in every democratic country except France where it was placed on a sound footing more than a century before the revolution by the celebrated ordinance drawn up by Colbert for Louis XIV.

Britain is still waiting for its Colbert. For many years before the war forestry had been neglected by successive British Governments and our timber supplies completely left to chance in the belief that cheap transport would bring so much as was required from overseas. The question of timber as an element in national defence had not been considered at all. The war brought a rude awakening. A Committee which has enquired into the matter reports that

£37,000,000 sterling was wasted during the first two years of war in increased freight and insurance and lost cargoes of imported timber—a sum which could have been saved if means had been devised earlier to utilise the woodland resources of the British Isles—a sum more than sufficient to have reconstituted the woods after the war and increased them to the extent that national safety demands. The home reserves of growing timber, though small indeed when judged by Canadian standards, were large compared to the area under wood. Felling had been discouraged since neglect and lack of organisation had rendered British woods unprofitable. The proportion of mature timber was thus much larger than is usual in European forests, which, except in Russia, are worked on a regular rotation and contain timber of all ages. When, under compulsion of the German submarine, the British woods began to be seriously attacked in the third year of the war, want of labour was the main difficulty and the needs of the war could not have been met without the



Photo by H. C. Weaver, Atlas, Sask.  
PLANTING TREES ON THE PRAIRIE.  
This shows what commendable results were secured by a young Saskatchewan farmer.  
Note the heavy growth of trees surrounding the school building in the background.

assistance of the Forestry Battalions and mills sent from Canada and Newfoundland. These mills, with their large and rapid output, were able to save a situation with which the small forest mills of the Old Country could not cope. Never in the whole of her history has Britain received assistance more timely or more generous.

#### Prepare for Emergency.

The woods have held out though the toll taken from them has been heavy. The British Government, alive at last to the vital importance of timber as an element of national defence, has taken steps to encourage replanting and to increase the area of woodland to a point which will ultimately enable the United Kingdom to dispense with imports of timber for a few years of emergency. Even when this programme is complete, the country will be far from self-supporting. The Government has now to turn its attention to the larger problem of safeguarding its supplies in time of peace. It is in view of this problem that our eyes turn to the Dominion.

#### Russia a Doubtful Source.

The United Kingdom imported in 1913, approximately 10,500,000 loads\* of timber, of which nine-tenths were coniferous, at a cost of £25,500,000, besides pulp and wood manufactures to the value of £14,000,000. For several years the imports had been increasing at the rate of 100,000 loads a year. Russia furnished us with no less than half of the total imports. By increasing her supplies, she had since 1899, not only made good the reduction in our imports from other sources, but had kept pace with our growing consumption. Is it safe to depend on Russia? The forest area contained in the Russian empire as it existed before the war was enormous—probably as large as the forest areas of Canada and the United States added together. Little information is available as to the proportion of merchantable timber or the probable cost of extraction, though the great rivers flowing north undoubtedly offer fine opportunities for transport. France, Belgium, Italy, Denmark, the Netherlands and Germany are all importers of timber and will have to draw on Russian reserves for their increasing consumption. Though the future of Russia looks black just now, it is almost certain that the changed regime will ultimately lead to development. If so, its own vast population will make heavy demands on the forests. The timber imported to Britain has for many years been steadily rising

in price and falling in quality. In the northern forests, from which the bulk of it comes, the growth of the trees is slow and even under good management it would take many generations to replace what is now being cut. All over the world consumption increases by leaps and bounds, except in the United States, where it has for many years been extravagantly high and is now coming under the control of a rising price. It would be folly to suppose that our grandchildren will be able to obtain from Russia the supplies they require. The question is whether they will obtain supplies at all unless we make timely preparation.

What ought to be done? The key to the situation appears to lie in Canada. Its forests contain the only great reserve of coniferous timber within the Empire. It is in the interest of Canada and of the Empire and most of all of the United Kingdom, that the forests should be conserved, exploited and regenerated with the utmost care and every facility provided for the distribution of their produce within the Empire and especially for its transport to Great Britain. Few will dissent from this ideal, but agreement about the means for reaching it is another matter. The subject bristles with difficulties and points of controversy. Fire protection alone is a hard enough nut to crack. A striking lesson has recently come to us from the United States. The terrible fire in Minnesota, accompanied by the loss of 1000 lives, following on a reduction of the annual appropriation for the forest service when expert opinion had demanded a large increase, is a warning to be taken to heart. It may well be impossible to prevent fires altogether just as it is impossible to stamp out disease. But it is certainly possible to detect and nip many fires in the bud and expenditure wisely directed to this object can certainly reduce, though it cannot eliminate the risk of great disasters. The Minnesota forest service established in 1909 had already reduced the annual property loss from a million to sixty-one thousand dollars. Nowhere has the subject of fire protection been more carefully studied than in Canada. The forest service has already good results to shew. Its work has passed the experimental stage and the time seems opportune for a great extension of its activities.

The transport problem also presents great difficulties due to the bulky character of timber and the fact that the eastward traffic of goods across the Atlantic already largely exceeds the westward. Possibly a solution may be found in some development of rafts.

\*One load equal to 50 cubic feet or 600 feet board measure. The figures include mining timber as well as sawn timber and logs.

### Canada's Sales to the U. K.

Over this great imperial question the statesmen of the Empire should lay their heads together. It is a disquieting fact that the timber exports of Canada have for obvious geographical and economic reasons been steadily diverted in recent years from the Mother Country to the United States. The present present time when the United States is curtailing its consumption of timber and increasing its exports is favourable for stemming this tendency by friendly arrangement with that country. It is the policy of Newfoundland not to export unmanufactured timber. That policy appears to be well justified by the conditions of the island and will no doubt be continued, though it was generously waived during the war. In Canada the conditions and the policy are wholly different. Yet the export of timber to the United Kingdom declined in volume by nearly a half between 1899 and 1913. In the latter year it represented less than an eleventh part of the British consumption. **This state of things ought not to be allowed to continue. It cannot be remedied without some modification of British policy. Besides making every effort to cheapen and hasten transport, this country would, in the writer's judgment, be justified in making a substantial contribution towards the development of fire protection in Canada and in levying such duties on imports from Russia and Scandinavia as may be necessary to place Canadian imports on an equal footing.** Inci-

dentally these duties would smooth the path of afforestation in the British Isles. The writer, though a free trader in principle, holds that the question of the country's future timber supplies is sufficiently important to transcend this or any other doctrine. To lose the chance of putting future supplies on a sure basis through reluctance to forego the cheap but uncertain supply from Northern Europe would, in his opinion, be an act of short-sighted folly.

The suggestion here made from the British point of view is commended to the consideration of readers. It is assumed that the Dominion would on its side spare no effort to further this trade with the Mother Country. The facilitation of transport within the Dominion might well form part of the bargain. The return flow of British goods to Canada would also have to be considered.

An arrangement under which the United Kingdom came to depend on Canadian timber would reach far beyond the immediate objects aimed at. It would form a real bond of mutual interest and bring the Dominion nearer to the British Isles. For these isles the only sane alternative is afforestation up to the hilt and afforestation carried beyond its economic limits, whether it encroaches on land fit for agriculture or is driven to barren and stormy heights, means a heavy drain on the Treasury without adequate return.

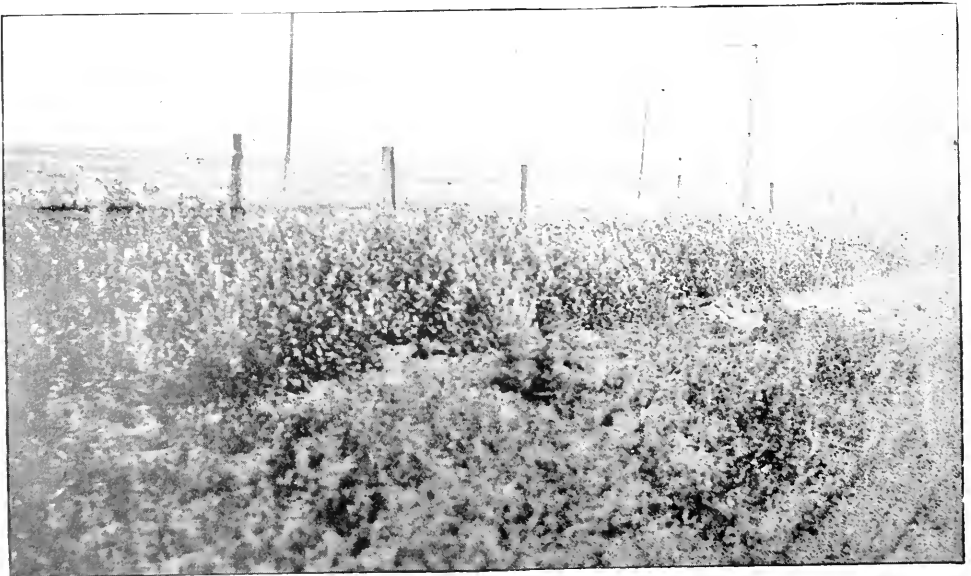



# THE MAKING OF A SPRUCE TREE

By Dr. C. D. Howe, Faculty of Forestry,  
University of Toronto.

(FIRST ARTICLE)

EDITOR'S NOTE.—Readers of *The Canadian Forestry Journal* will welcome this series of twelve articles by Dr. Howe. Each is popularly written and so brief that none may well plead lack of time.

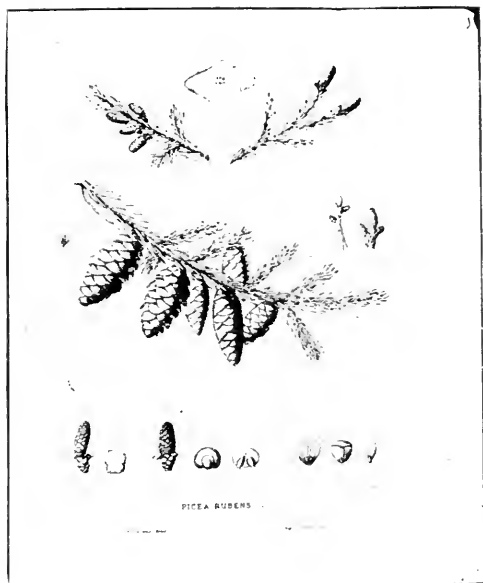

In the centre, a fruiting branch of red spruce.

Above it, at the left, a branch with male flowers; at the right, a branch with female flowers. Note that the latter are at the tips of the branch.

Lower left-hand corner, a single male flower and beside it at the right the sac which contains the yellow powder.

The third figure from left to right is a female flower. The next two figures to the right show the little cases in which the female cell is borne, one in each case.

The three figures in the lower right-hand corner represent the seeds which developed from the little cases indicated in the paragraph above. Two winged seeds are borne on each scale.

A seedling is shown at the left of the centre and some winter buds at the right.

The figure at the top centre represents a cross section of a leaf. At the middle are conducting strands and at the margins resin ducts.

The figures represent the objects about one-fourth their natural size.

It is my purpose to tell you how a tree is made, to trace its life history from the very beginnings through its infancy, youth, maturity, old age and decay, until it is finally absorbed into the body of all-mother earth from which it sprung.

In the first place it should be held clearly in mind that trees and the higher plants are separated into sexes in the essential respects as clearly distinguishable as in the higher animals. The distinctive organs, however, are very often borne on the same body, as is the case with all our narrow-leaved evergreen trees, such as the spruce, pine, hemlock, cedar and balsam. They are borne on separate individuals in the poplars and willows, but there is no sex modification of body, the male and female trees being indistinguishable except when in flower, since the flowers contain the sex organs.

## The Female Flowers.

On the tips of small twigs, usually at the very top of a spruce tree, one might find by looking sharply in May or June little upright knobs about a half inch long and as thick as a pencil. They may be green like the leaves or purple, or pale red according to the kind of spruce that bears them and they are composed of 25 to 50 soft overlapping parts called scales. At the base of each scale rest two little flesh-colored bodies about the size of a pinhead; each of these contains the essential female cell and each has the power, under certain conditions, of developing into a seed. Carrying out the idea of sex distinction in trees, then, we may call these various colored knobs on the top branches the female flowers. Later in life they become the cones. The reader may be more familiar with a pine cone. A spruce cone is built on the same plan as a pine cone, but it is smaller and not so noticeable, especially when it has fallen to the ground.

In another portion of the tree, usually at the outer tips of the lower branches, one might also find other little knobs very much like those in the highest branches. Instead of being upright

in position they hang head downwards; they occur in much greater numbers and are often conspicuous because of their bright yellow color when ripe. The color is due to masses of yellow powder contained in two little sacs at the base of each scale. When the branches are jarred by striking the tree with an axe or when they are swayed by the wind, the powder is shed in sulphur colored showers. Each grain of powder is capable of developing within itself the essential male cell, so we may call the structures producing the powder-like substance, the male flowers.

### The Miracle of Tree Creation.

Nature abhors inbreeding and she makes it difficult for the male and female cells of the same tree to meet; in this case by placing them twenty feet or more from each other in a vertical direction. The yellow powder of a tree higher up the slope, however, or that from another tree some distance away on the same level, is borne by the wind to the topmost branches bearing the female flowers. They are dusted with the powder and it works its way in between the scales which stand slightly apart at this time. Each little grain of powder, so small that it would have to be magnified fifteen or twenty times to be seen with our eyes, now develops a minute tube which grows along between two scales. When it reaches the little flesh-colored body at the base of a scale, the tube has developed within itself a male cell which finally meets the female cell; the contents of the two are mixed together and the miracle of creation is performed; a new spruce tree begins its life. At this stage several of these little trees, perhaps a dozen or more, could rest comfortably on the head of a pin, but each contains an impulse and a power which, if conditions are favorable, will lead it on, and force it on, until it has developed a body 100 feet tall, two feet in thickness near the ground, and weighing several tons! Surely this is a miracle.

If you are sufficiently interested to read certain articles in the following numbers of the "Journal" you will learn how this miracle is performed; how an invisible, microscopic cell develops into a giant forest tree.

(Next article in March issue).

### WANTED: FOUR FRIENDS!

We have some extra copies of the January and February issues to send free of charge to your friends.

Will you give us four or five names?  
Possibly you may prefer a 'short cut.'  
By that we mean pinning a dollar bill to  
a friend's name. We will notify him of  
your thoughtfulness.

CANADIAN FORESTRY JOURNAL,  
206-207 Booth Bldg., Ottawa.

### BOLSHEVIKI SEIZE TIMBER.

The timber trade of Russia—what remained of it outside of the White Sea district—has been dealt a death blow by the recent Bolshevik decree that exports of Russian woods are forbidden and that private lumbering must stop. The decree, which affects all district of Russia under Bolshevik control, declares that "all work in connection with forests and trade in timber and all wood manufacturing will be taken over by the local Soviets, and all export is forbidden." It is stated that this decree relates to the nationalization of all property in land, one of the main planks of the Bolshevik platform.

No one, of course, takes the edicts of the Reds very seriously, doubting the permanence of them and their makers; but they complicate the industrial and economic situation in Russia greatly and have caused certain interests substantial losses. The Norwegian newspaper in Petrograd, *Nording Kommune*, states that this decree hits Norwegian interests particularly hard, as much of their properties, representing millions of crowns, lies in Bolshevik territory.

It will, however, not affect the timber trade of the White Sea district, as it does not recognize Bolshevik authority, and the manufacture there of a certain quantity of saw wood is expected during the winter, as is a continuation of exportation during the next shipping season, even though on a considerably reduced scale.

### LUMBER STUDY BY MAIL.

Moscow, Idaho, Feb. 1.—The correspondence course in lumber and its uses announced some time ago by the school of forestry, University of Idaho at Moscow has met with ready acceptance, the enrollment exceeding expectations. The course was offered in response to a demand for information, in convenient form, regarding the properties of wood and the adaptability of different wood to different uses, standard grades and sizes, structural timbers, seasoning and preservation of wood, lumber prices, lumber production, and the war time uses of wood.



His Majesty, King George, congratulates a Canadian lumberjack on his uncommon skill in felling a tree.

## THE MIRACLE OF GASCONY'S PINE

By *Brigadier-General J. B. White, D.S.O.,*  
*in Command Canadian Forestry Corps*  
*in France.*



### How Pine Planting Converted an Out-at-Elbows Desert into the Richest French Department.



Note: One hectare=2.47 acres.

The history of the planting of the pine in the Landes of Gascony is a very interesting and wonderful object lesson, due to the fact that in about 70 years this great area of over 2½ million acres was changed from practically a barren waste of no value, into a huge forest which at the present time is valued at from 10 dollars per acre on recently cut over land to 500 dollars per acre for timber almost mature in 50 years. **In the same length of time the population increased from 70,000 to 300,000, and the department of Landes was changed from being the poorest department in France to the richest.**

#### Human Conditions Changed.

About the end of the eighteenth century the Landes consisted of a vast sand waste, supporting only a scanty vegetation of small plants, with here and there at distant intervals, small islands of short, brushy Maritime Pine. In the winter, the season of greatest rainfall, the country was a series of lakes and marshes, while in the summer the hot sun dried up the scanty vegetation and left the place practically a desert. In this country the social conditions were pitiable. Living in crude shelters with no transportation, little food, and no medical attendance,

fever and other diseases played havoc with the scattered population. A scanty livelihood was made by raising sheep on the sand plains, but due to the lack of food this was a difficulty. Cattle and horses could not be raised at all.

The first attempt to colonize the country was in 1610 when Henry IV welcomes 45,000 Moors, expelled from Spain, and induced them to settle in the country, but since they could not make a living they departed to Northern Africa soon after.

The first real sowing was done in 1801, following a well formulated plan. This sowing took place with a grand ceremony at the mouth of the Gironde River, and soon after at several points along the coast further south. This planting was under the direction of the Department of Gironde, but in 1808 a commission was formed in the Department of Landes and the two Departments co-operated throughout. The planting of the dunes was finished about 1860, 102,000 hectares having cost about 10,000,000 francs, or about 100 francs per hectare.

#### Napoleon's Purchase.

As an example to proprietors to plant up their waste lands Napoleon III bought up in 1860 a block of 7,400 hectares at 80 francs per hectare, which was higher considerably than the prevailing price at that time. In six years this was drained, 7,000 hectares were sown with pine seed, 400 hectares were placed under cultivation to raise food for the labourers, the necessary buildings constructed to house them and two nurseries for young trees started. This work included 218 kilometres of ditches, 95 kilometres of roads, and 89 kilometres of wind breaks and shelter belts. The sowing of the pine alone

cost 21 francs per hectare. The total expense including the cost of the land was 1,745,000 fr. or 235 fr. per hectare. Immediately after being finished, the property, without counting the buildings, was valued at 3,529,000 francs.

Since the finishing of the reclaiming of the sand lands in 1870 the regeneration of new forests has all been by natural means, except in odd cases on an old pasture or mill site or land under cultivation, in which cases pine seed was sown or young trees planted. The only precautions taken to insure natural regeneration are that about ten years before the final cutting the gathering of cones is prohibited, and after cutting the brush is cut to give the young trees a start, and pasturing on the area is prohibited.

#### Method of Planting.

The usual method employed in planting in the Landes was to sow the pine seed broadcast mixed with either genet seed or that of gourse, after the brush had been burned which would smother the young seedlings.

To secure the pine seed the cones are gathered from October to March, placed in heaps and covered with brush. In June, July and August, when the sun is warmest, they are placed in the sand standing on end, so the seed do not drop out.

Occasionally when it was desired to plant seedlings, an open space fairly moist would be selected in the timber and pine seeds sown there broadcast, so as to form a dense stand of seedlings. One hectare sown in this manner would furnish sufficient seedlings for from ten to fifteen hectares.

---

## WHERE DO THE SEEDS COME FROM?

---

Readers of the Forestry Journal will be much interested in the investigations of Mr. J. V. Hofman, Forest Examiner in charge of the Wind River Experimental Station, Idaho, into the origin of the seed from which certain types of forests rehabilitate themselves on many burned and cut over areas. Mr. Hofman is referring, of course, to a district in which Douglas fir, western white pine, noble fir, western red cedar and western hemlock predominate.

Says Mr. Hofman, in his first words of introduction:

"On many burns and cut-over areas in the Douglas fir and western white-pine region of northwestern Idaho, Washington, and Oregon

there are found dense and irregular stands of young growth, the origin of which can not be traced in any way to the seed trees left after cutting or burning. The effort to find the true source of seed of these stands began with a study to determine the efficiency of seed trees in restocking the ground and the distance to which seed is disseminated."

The investigator goes on to present the results of his experiments and then says:

"The foregoing facts first cast a doubt upon the long-accepted theory of the restocking of large forest burns by the process of wind migration and finally proved it untenable. As the study progressed and this fact grew steadily

more convincing, there arose naturally the question, 'What was the source of seed for all this reproduction?' The answer to this question also developed naturally enough the accumulation of evidence throughout the burn. It was found that the reproduction most often occurred, not in a solid unbroken cover, but in various-sized patches with very irregular and ramifying boundaries. Where the reproduction was lacking, the ground was covered with grasses, herbaceous plants, and shrubs, evidencing an uninterrupted growth since the burn was formed. The occurrence of these two types of cover made an interlaced pattern resembling mosaic over the entire burn, although each type often expanded solidly over a slope or basin many acres in extent. Everywhere the feature that was most striking was the sharp line of demarcation between the reproduction and the grass areas. For all its tortuous windings the boundary was always distinct. Obviously such a condition could not have resulted from any process of overhead seeding, but must rather have been produced by some action on the surface of the ground itself. The idea of ground fire suggested itself. One who has seen ground fire burning in forest duff will remember that it burns very irregularly, here leaving an island and there forming a deep bay between two points of unburned ground. When at length the smoldering fire is stopped, the result is just such a mosaic of burned and unburned territory as has been described for the reproduction and grass territory.

"The likelihood that any part of the forest floor will burn depends on a number of varying factors, such as the quantity and kind of humus soil and its moisture content. Most severe ground fires occur on dry sites, provided those sites have a sufficient quantity of duff to carry fire at all. Accordingly the reproduction occurs most densely in the moist sites and is open or lacking on exposed dry sites, although this may be partly due to the fact that these dry sites are very unfavorable to the establishment of seedlings even though germination may take place. Furthermore, irregularity in the areas of young growth occurred on all sorts of sites. This could lead to but one conclusion: wherever ground fire occurred no reproduction appeared, except close to seed trees where seed could be cast upon the burned ground after the fire.

"From this it was but a step to the complete explanation: wherever the duff and litter were burned out of the forest floor, there developed an area barren of reproduction; wherever the duff

and litter were not burned out of the forest floor, there developed an area of more or less dense reproduction. Therefore, the duff must be the controlling element: the duff must be the storage medium of the seed, and that seed must have been produced and stored in the forest floor before the fire and have retained its vitality through the fire.

"Before this conclusion is accepted, however, another possible source of seed must be considered. Is it not possible that cones carried through the fire on the crowns of trees severely burned or killed furnished the seed from which the young growth originated? After the fire these cones may possibly have opened and dispersed their seed, becoming in that way an overhead source for the restocking of the burn. In fact, a very small percentage of germination of white-pine, noble-fir, and cedar seed has been secured from seed which passed through a crown fire. But even though this source does contribute some seed, it does not explain the great mass of reproduction, which, by its mosaic occurrence, demonstrates conclusively the impossibility of its having come from overhead seed distribution subsequent to the fire. The principal factor in reproduction after fire must be the seed stored in the duff.

### LAMINATED GUN STOCKS.

The U.S. Forest Products Laboratory at Madison, Wis., has developed a method of making laminated gunstocks which would, without reducing the strength, permit the use of the small pieces of walnut not suitable for single piece stocks. This would facilitate production and result in appreciable saving in costs and material.

The application of laminated construction to many articles of trade is a development worthy of close study. Shoe lasts, bowling pins, saddle trees, oars and paddles, tanks, barrels and kegs, and various parts of vehicles and agricultural instruments may possibly be constructed with laminated wood.

The laboratory is working on the drying of willow for artificial limbs. There is a shortage of material and the demand for artificial limbs will increase. It takes from three to five years to air-season the stock, but indications are that it can be done in kilns in from sixty to seventy days.



### EVOLUTION OF THE MOUNTAIN LOOKOUT STATION.

At the top is the old style crib, or log fort type. At the side we have the wooden tower of later date. On the opposite page is shown the modern steel tower or observatory.

Pictures by courtesy of Forrest H. Colby, Forest Commissioner of Maine.

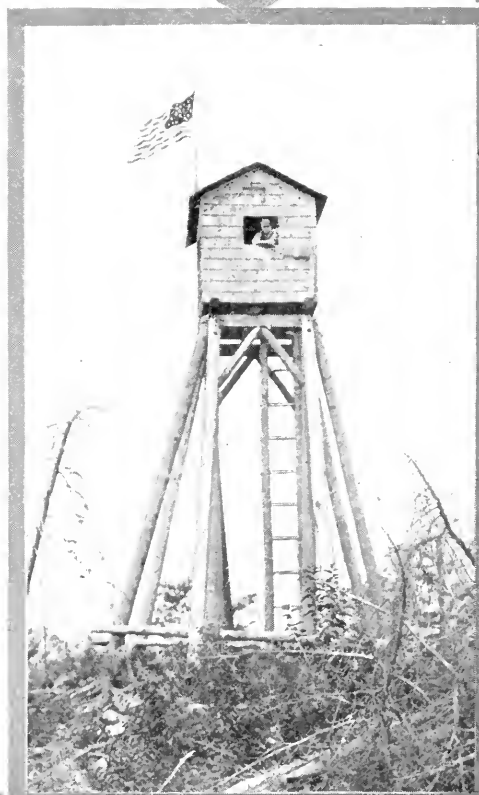

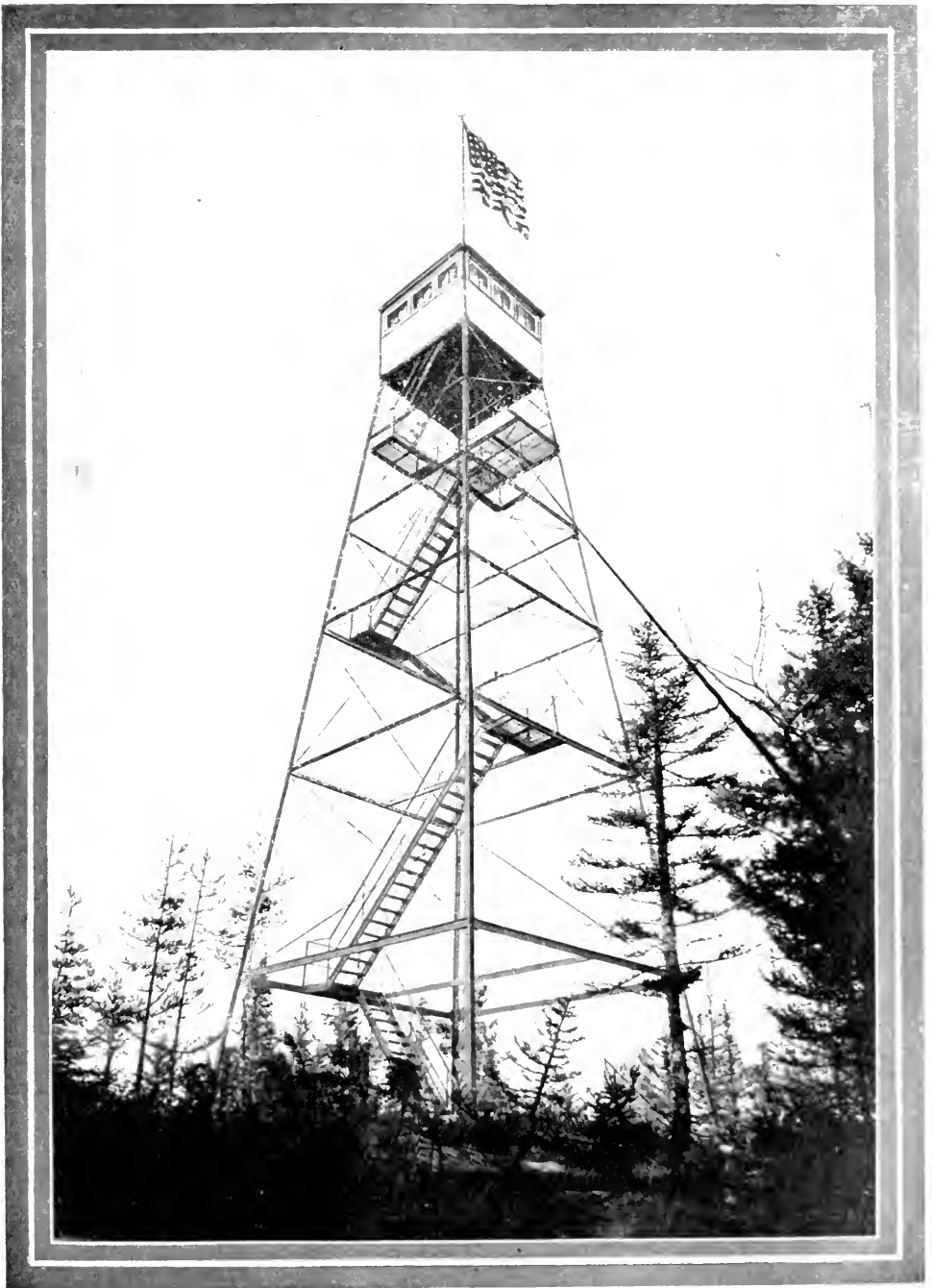

# THE STATE'S DUTY IN MANAGING FORESTS

By Hon. E. A. Smith, Minister of Lands and Mines,  
New Brunswick.

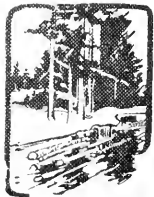

Present Employment and Revenues From Forest  
Industries Must be Maintained for  
All Time to Come.



At no time has the obligation of a government to prepare for the future been so conscientiously realised as during the present period of Canadian history. Public opinion and administrative policies are recognising with startling frankness the duty of the state in managing the natural resources of a country on the most scientific, far-sighted, permanent basis in the best interests of all concerned.

What, then, is the chief natural endowment of the people of New Brunswick? Certainly the forests. Over seven million acres still remain in the right of the Crown, and from which each and every citizen of the Province is equally entitled to receive his share of prosperity represented by the timber revenues spent in the development of the country, construction and maintenance of schools, roads and bridges.

## The Future of Employment.

It would appear, therefore, that forest conservation is emphatically public business. The Government, as the trustee and steward of this, the people's heritage, must manage and regulate it, not for this generation alone, but for all future generations as well. Not from the material standpoint of Government revenue alone must this be done, but it is also important that the future be considered in all forest policies, in order that the annual distribution by the lumber industries of over fifteen millions of dollars for wages, supplies, etc., to the people of New Brunswick may be continued for all time.

How, then, may the forests be kept permanently productive? Briefly, this comes under two great divisions. First, by adequate fire protection. It is estimated that if the timber destroyed by forest fires in New Brunswick during the last forty or fifty years had been manufactured into lumber, the vast sum of fifty millions of dollars would have been circulated in the province. The First Law, passed at last session, has been



HON. E. A. SMITH,  
Minister of Lands and Mines, New Brunswick.

designed to assist in preventing a recurrence of so great a national disaster. That is why the farmers of New Brunswick are asked to secure a fire permit before setting their slashings on fire, in order to protect their own prosperity. Secondly, and also equally important, by the observance of all reasonable logging regulations by the operators, the elimination of all unnecessary waste and the leaving of under-sized trees standing to grow and provide the future crop of timber.

Private assets are never managed in ignorance of their extent, character and condition. Why, then, should a Province attempt to administer its



forests without a full knowledge of this great resource? The New Brunswick Forest Survey and reclassification of Crown Lands was designed to provide just this information. Almost one quarter of the Provincial Forests have already been examined, and the results so far obtained have fully justified the cost.

#### Politics on the Scrap Pile.

It was recognized that without a permanent, properly-disciplined and efficient field staff of forest rangers, unhampered by the influence of politics, very little of the above objects could be accomplished. Consequently the 1918 Forest Act was passed, providing for a Forestry Advisory Commission of five members, two members of which are practical lumbermen and represent the lumber industries of the Province. This Commission controls all permanent appointments to the Forest Service. Applicants must pass a searching examination and give six months' satisfactory service before receiving a permanent appointment. The actual selection and appointment of our Forest Rangers and Inspectors on this basis of merit alone, which is just being completed, is considered one of the most vital and important steps in the organization of any Forest Service, and in the permanent progress of forestry in New Brunswick. The Commissioners feel that through the appointment by competitive examination they have secured a splendid staff of Rangers, and they look for a reasonable and just treatment of all the various matters coming under a Ranger's duties.

#### New Way of Selling Timber.

A most important departure was the recent adoption of a short term timber sale policy in regard to some hundreds of miles of expired timber licenses. The price obtained for this timber by open competitive bidding varied from \$5.50 to \$7.75 per thousand feet, and had the effect of fully justifying this unusual procedure, which is unprecedented in New Brunswick's forest policy.

#### Looking to the Future.

New Brunswick has won world-wide fame as the "Land of Comfortable Homes." It has been said, and truly so, that the success of the home-makers depends in the long run on the wisdom with which a nation takes care of its forests. It is therefore our duty as statesmen to so direct the utilization of our forests that we shall conserve this greatest natural resource of our land, and in our turn hand down to posterity unexhausted that noble heritage so freely bestowed by Nature.

#### FOR STANDARDIZATION.

A new branch of the Canadian Forestry Association, to be known as the Standardization Committee, was authorized at the Annual Meeting at Montreal, with the following as members:

- G. H. Prince, Chief of Forest Service,  
Fredericton, N.B.
- L. S. Webb, Forester, Forest Service,  
Fredericton, N.B.
- J. H. White, Asst. Provincial Forester,  
Forestry Branch, Toronto.
- L. E. Bliss, General Supt. Forestry Branch,  
Sudbury, Ont.
- T. W. Dwight, Asst. Director, Dominion  
Forestry Branch, Ottawa.
- J. B. Harkin, Commissioner, Dominion  
Parks, Ottawa, Ont.
- Henry Sorgius, Manager,  
St. Maurice Forest Protection Assn., Ltd.,  
Three Rivers, P.Q.
- B. Guerin, Manager, Western Div.,
- J. D. Brule, Manager, Eastern Div.,  
The Southern St. Lawrence Forest Protec-  
tive Assn., Ltd., Quebec, P.Q.
- Arthur H. Graham, Manager, The Ottawa  
River, Forest Protective Assn., Ltd.,  
Ottawa, Ont.
- R. L. Seaborne, Manager, The Laurentian  
Forest Protective Association, Ltd.,  
Quebec, P.Q.
- A. Bedard, Fire Inspector, Provincial Forest  
Service, Quebec, P.Q.
- H. C. Johnson, Fire Inspector,  
Board of Railway Commissioners,  
Ottawa, Ont.

It is proposed to add representatives of the British Columbia Forest Service; The Canadian Pacific Railway Forestry Branch; The Canadian National Railways Fire Inspection Department, and others who are now engaged in forest fire protection work in Canada.

Primarily the Committee's work is to endeavour to standardize fire laws and regulations, forms and reports, fire warning posters, publicity literature, etc., tools, equipment and supplies, mechanical equipment and accessories; also, to seek, encourage, experiment with and develop new ideas, methods, and apparatus, all in connection and allied with the profession of forest fire protection. Wherever standardization can be arrived at, it is suggested that one of the benefits protective organizations can secure, is a reduction in the cost of such items as posters, publicity literature, tools, mechanical apparatus and accessories, by combining their orders for such items with those of other organizations.

# THE TREE-SOLDIERS OF FRANCE

By Major Barrington Moore, Second in Command  
U. S. Forestry Corps.



## Drastic Drain of Military Needs Amply Provided for by French National Foresight.



My subject is the part played by the French forests in the war, and the work of the Canadian Forestry Corps and American Forestry Section in utilizing these forests. I shall speak only of the broader aspects of these operations.

After the first two years of the war, the tonnage shortage made it impossible to ship wood to France, except aeroplane stock and the like, for wood is very bulky and the necessary shipping would have been enormous, more than could possibly have been spared with safety. Yet wood is a military necessity.

The ports of France were not built with a view to the landing of large armies, and were wholly inadequate; yet the speedy debarkation of the troops, with their munitions and supplies had to be assured at all cost. The submarines forced the ships to come in convoys of ten or fifteen at once, requiring several times the docking space the same number of ships would have needed singly. Wharves, miles of wharves, were of immediate necessity. For this we must have piling and wharf timbers.

But, once the troops and supplies were landed our difficulties did not end. It was necessary to find shelter for them. Sacks of flour cannot be left out in the rain. Warehouses became necessary, warehouses of gigantic size and capacity. Railroads had to be laid in the warehouses, one depot alone requiring 85 miles. Lumber for these warehouses had to be furnished immediately.

Wherever possible we billeted our troops in houses to save barracks. But the crowded condition of the country, owing to the refugees from Belgium and the invaded parts of France, made this inadequate. Our men were dying of pneumonia. We simply had to have barracks. Every suitable building that could be found anywhere in France was turned into a hospital, but yet there were not enough. We required large quantities of lumber for hospitals.

After the army was landed, its supplies cared for, and the men were in billets or barracks—in all of which wood plays the leading role—the army must be moved forward. As a matter of fact, it had to be moved forward even before the preparations for landing were completed. Everything was done under the utmost tension, and still not rapidly enough.

### Ties Before Guns.

The transportation of men and guns, with munitions and supplies, required the construction of new railroad lines and the double tracking of others. Ties became more important than guns, because without the railroads the guns could not be brought to the front. When the Germans broke through in March and got within close range of Amiens, they paralyzed the main artery between the French and British armies. Another railroad had to be built, and built quickly. Fortunately the Canadians had ties ready cut for an emergency.

In order to permit one organization to communicate quickly with another, it was necessary to construct telephone and telegraph lines. This called for thousands and thousands of poles.

Cooking the food and keeping the men warm meant tons and tons of fuelwood.

At the front, trenches and other defensive works called for large numbers of props, barbed wire pickets, and other round material.

To bring up the artillery quickly over the shell-torn ground it was necessary to build hasty roads with five inch plank. The amount of lumber consumed as road plank was enormous.

Add to the foregoing an insistent demand for lumber to make packing cases and for countless smaller uses, and you will have some slight conception of wood as a military necessity.

### Forestry Troops Urgent.

We had not been in France long before this necessity for lumber faced us in terrible earnestness. Our army engineers had always found at hand whatever materials they needed, and they drew up elaborate plans accordingly. The Chief

of Engineers of the A.E.F. called in Colonel Graves and made him responsible for furnishing the lumber to carry out these plans. Accordingly Col. Graves and I went to work to procure it. We knew that the tonnage shortage prevented our importing it, but we understood that the French would fill our first requirements.

What was our dismay to learn that by furnishing us lumber the French had simply meant they would furnish us the trees standing in the forests! They had no piles, and they had not enough lumber or ties for themselves. Even worse, they had no labor. What were we to do? The situation was critical. Our troops were on their way over, and we had nothing built to receive them, nor any materials with which to build. We must have forestry troops and sawmills at once. Mr. Claveille, the Chief of the French transportation system, told us with vivid emphasis that failure to send forestry troops promptly would spell disaster. Gen. Pershing was so anxious about the situation that he personally dictated an urgent cable asking the War Department to stop sending fighting men until they had first sent forestry troops.

But, what will be the use of sending forestry troops and sawmills unless there is enough standing timber? The vital question then was, did France possess enough standing timber to fill the indispensable requirements not only of their own army and civil population, but of the British army and the American army as well? The construction program of the American engineers called for lumber in quantities which staggered the French.

### The Foresight of Forestry.

Fortunately, France did have the forests. The situation was saved, the war shortened by many long months. And why did she have them? Because she had practised forestry for generations.

We must not imagine that she always practised forestry. Like other countries, she began by destroying her forests. Eventually, however, she saw the disastrous effects of her recklessness, and gradually turned from destroying to restoring, and then to building up. For example, 100 years ago the southwestern corner of France, extending from Bordeaux to the Pyrennees Mountains was almost as treeless as the prairie, and was fringed by sand dunes which were constantly in movement, burying fields and houses and even whole villages. Napoleon called in engineers and foresters. These men succeeded in holding the dunes in place by planting with maritime pine; and then they planted up the



BRIGADIER-GENERAL J. B. WHITE, D.S.O.,  
in command of Canadian Forestry Corps operations  
in France; a Director of the Canadian  
Forestry Association.

whole interior of the region with the same tree. During the war this region was the largest source of lumber not only for the French army but for the British and American armies as well.

### A National Enthusiasm.

The French forests were, therefore, not simply nature's gift, but the fruit of conscious effort, applied with painstaking care and industry through long years.

Forestry to a Frenchman is the accepted way of handling forests. He cannot conceive of handling woodlands in any other way. In France everybody, even those who are not foresters or lumbermen, understands what forestry means. When you say you are a forester you don't have to stop and explain as you do in America. It is just as clear as if you said you were a lawyer or a doctor. This universal understanding of the aims of forestry is the most potent factor in the upbuilding of the forest resources of any country. The Canadian Forestry Association can render no more valuable service than by disseminating this idea. It is to the interest of the lumberman to have a perpetual supply of timber to cut; it is to the interest of the wood using industries to have a

permanent source of raw material; and it is to the interest of the country as a whole to be independent of outside sources of supply.

No wonder then that the French valued their forests, and were unwilling to have them needlessly destroyed. They did not forget the years of toil they had spent in creating them. They were willing to give up all the timber that was ready to cut, and even to sacrifice that which they would not normally have cut for ten or fifteen years. But they were firm against annihilating any forest, or cutting it in such a way that it could not recover with reasonable care. They, therefore, maintained absolute control over the methods of cutting. On the Government owned forests, they were particularly strict, marking every tree to be cut and prescribing in detail the methods of brush disposal, etc. On private lands the owner marked or designated in the contract those trees which he would sell. He also laid down the manner of brush disposal and other operations. Ultimate control was vested in a committee composed of representatives selected by the Minister of Agriculture, the Minister of Munitions, as well as all other interested members of the cabinet, and representatives of the lumber industry. Under these conditions we had little choice as to methods of cutting.

You are doubtless wondering how the Canadian and American lumbermen got along when they had carefully-managed forests to cut.

#### Overseas Men Careful.

The operations were uniformly well carried out. The stumps were cut so low you could hardly see them; the tops were chopped into cordwood, and the slash thoroughly cleaned up. The cutting areas of the Canadians and Americans were generally better than those of the French wood merchants themselves. This goes to show that the lumberman can cut under forestry methods when he has to. He can do it even when subjected to the greatest imaginable pressure for quick production; and what is more, he does it well.

The organization of the American forestry section was patterned largely after that of the Canadian Forestry Corps. When Col. Graves and I landed in France in June 1917, we went first of all to the British Forestry Directorate at La Touquet. General Lord Lovatt received us with the greatest friendliness, and gave us complete data which he had prepared in advance, covering his entire organization and equipment. Then, after a trip to the Canadian operations under Col. Johnson on the Government forest of La Joux in Eastern France, and after working

over the information collected, we drew up a cable outlining the organization of the forestry troops required by the A.E.F. We based our requirements on an army of two million men, and asked for 18,000 forestry troops, of which 7,500 were to be skilled lumbermen, about 4,500 engineer troops for road and camp construction, and about 6,000 unskilled labour. At the same time we requested twelve officers to come over at once for our overhead organization. These officers we asked for by name. They arrived in about two months, in time to be of great service in acquiring standing timber and other preparatory work. The unit of the Canadian Forestry Corps is the company. We made ours the battalion on account of our army regulations; it was hard at first to make our superiors see the need for elasticity. Forestry troops were an entirely new venture. The number of men in the actual operations depended entirely upon the needs of the case. Sometimes only 50 men would work together and then again, we would have a thousand or more.

#### Fighting Speculators.

The standing timber was all bought through an interallied committee composed of French, British and Americans; later the Belgians were represented. We ourselves selected each forest, in company with a French officer, and then laid it before the committee. The negotiations with the owner, and purchaser, were done by the French. The French possessed the right of requisition, and used it effectively, saving millions of dollars and defeating the swarms of speculators which buzzed around us like flies around the honey pot. By persistent efforts we managed to acquire timber enough to keep ahead of the operations. But toward the end it was becoming more and more difficult to find reasonably accessible tracts. Accessibility was of prime importance in selecting timber because of the need for rapid production. If the war had lasted we would have been in a difficult position. When it ended, we were planning to do railroad logging in the mountains.

Logging conditions varied greatly. The southwestern pineries are as level as a table, except for the dunes along the edge, and resemble our southern long leaf pine country. Central France is level or rolling, the chief obstacle being the heavy sticky clay. Here the forests were mostly oak, which we cut into ties, wharf timbers, and road plank. The silver fir forests of Eastern France were in the mountains. Our chief trouble there was the narrow gauge railroads

which never had enough cars or engines. The same kind of narrow gauge railroads bothered us in other regions as well.

### Prepared for 42,000 Woodsmen.

Last autumn, before the armistice was signed, our War Department planned to have four and a half million men in France by July 1919. This meant an enormous increase in the lumber requirement. To meet it we planned to bring over 24,000 additional forestry troops, or a total of 42,000 men, two thousand of which were to cut for the French and British. The men were already being recruited when hostilities ceased. Whether or not France could have furnished the timber for this force, as well as for the British and French armies is difficult to say. Certainly we would have been hard put to it, and been compelled to operate some very difficult tracts.

We had to get ready cut lumber, ties, and piles for immediate needs pending the arrival of the forestry troops. We had to continue getting this class of material even after the arrival of the forestry troops because the War Department increased the numbers of fighting men beyond what we had anticipated when we drew up the organization of the Forestry Section. The British and French helped us in this with wonderful generosity, giving us material from stocks sorely needed for their own armies. We developed to their utmost all European sources, Switzerland, Portugal, and even Spain. This last was the work with which I personally was most concerned after the arrival of the forestry troops.

When we consider that the modern army is helpless without wood, I think it is safe to say that the French forests were one of the big factors in winning the war.

### Timber a Vital Need.

Had not the standing timber been in France to cut, it would have been useless to send forestry troops, and we would have been compelled to use precious tonnage in bringing the wood to our armies. We all know how critical the situation was during the German drives from March to July. Every man and every gun was needed. The drive in March was checked by a handful of men who had never fought before, laborers, camp cooks, anyone who could hold a rifle. The need of men and guns was so great that England cut down her importations of food to get tonnage to bring men over. The people went without sugar, they went without butter and other fats, they had almost no meat and a miserly slice of

bread each day. They reduced themselves to the verge of starvation just to get a few more ships to bring soldiers to France. Had it not been for the forests of France, these ships, yes and even more ships, would have had to bring lumber instead of men.

We have seen then, that wood is a military necessity and that, owing to the shortage of ships we could not have brought the necessary men and guns to France if there had not been the French forests to supply wood. We have also seen that these forests are due to the efforts and industry of skilled foresters backed by the people.

In concluding, I wish to take this opportunity of expressing my profound admiration of the Canadian Forestry Corps, and deep appreciation of their generous and unfailing assistance. A finer lot of men I never hope to meet. When Col. Graves and I landed in Bordeaux in June 1917, wholly ignorant of what lay before us, Col. Miller in charge of the Canadians in the region, called upon us and not only extended to us every courtesy, but gave us much valuable information. I have already spoken of the assistance we received in drawing up our organization. Gen. White was particularly helpful with friendly counsel. When our forestry troops had arrived but were unable to commence sawing because our mills had not yet come, Gen. McDougal lent us five Canadian sawmills, three of 20,000 foot and two of 10,000 foot capacity, with full equipment. I feel that I speak for all the American lumbermen and foresters in France when I say that we can never adequately repay our debt of gratitude to the Canadians.

### NORWAY TO HELP FRANCE.

Norway intends to help out the restoration of the devastated part of France, in the front zone, by planting a belt of Norwegian forest trees. Much enthusiasm has developed for the scheme, and it is intended to begin this spring. It comprises the planting of 250 acres annually, for five years, and the money is streaming into Consul Heiberg, at Christiania. The idea is to send a forestry party of about fifty Norwegians, fully equipped with trees, tools, tents and stores, so as not to impose the slightest burden on France. The tentative zone for planting the belt of trees is from Adrennes towards the Belgian frontier, behind Arras, where there formerly was fine forest, but action will be taken in accordance with the desires of the French.



Photo by F. H. Kitto, D.L.S., Natural Resources Intelligence Branch, Dept. Interior.

OUT-OF-DOORS IN MANITOBA.

- |                                      |  |
|--------------------------------------|--|
| 1. The original Flin-Flon camp.      | 4. Roman Catholic Hospital at The Pas. |
| 2. Flin-Flon Lake.                   | 5. View from high bank of Amisk Lake.  |
| 3. Amisk Lake from Copper Portage.   | 6. A choice camping spot.              |
| 7. Northeasterly part of Amisk Lake. |  |

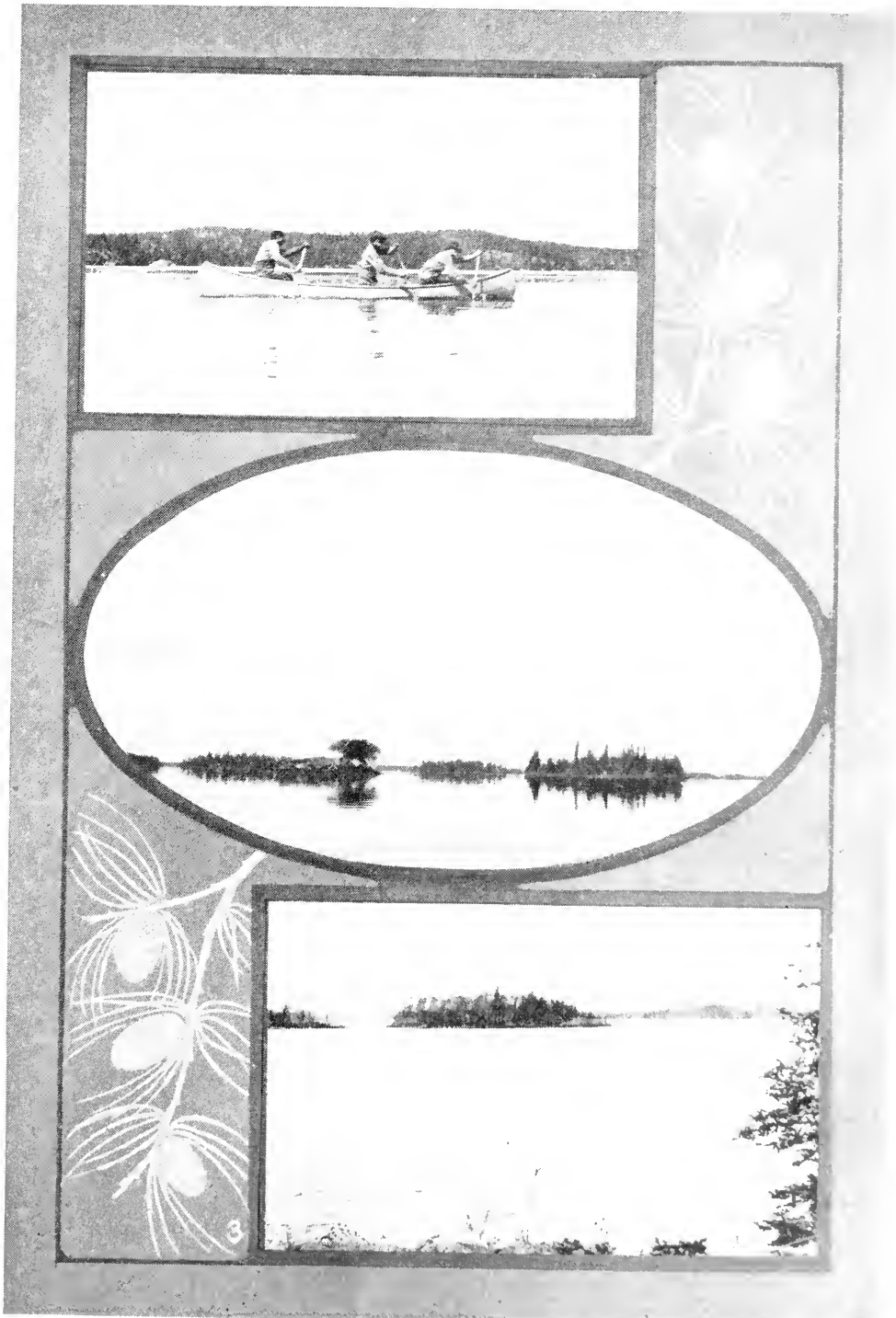

Photo by F. H. Kitto, D.L.S., Natural Resources Intelligence Branch, Dept. Interior.

**OUT-OF-DOORS IN MANITOBA.**

1. Indian Canoeing.      2. A Summer Day on Reed Lake.      3. Island Lake.

# THE DAY AFTER TOMORROW

By Robson Black in "The Monetary Times", Toronto.



## A Plea for Constructive Public Action in Establishing Wise Methods of Handling Forests.



Of all the family of natural resources, the forest is the shyest advertiser. This has been damaging enough in a land where public policies go to the pushful. We cannot realise the national seriousness of it however, until we thoroughly grasp the fact that the perpetuation of forests in Ontario, for example, is primarily state business and that timber conservation is more the concern of the Niagara school teacher and the Cobourg grocer than of the 'lumber baron.'

Canada's forests owe perhaps their greatest grudge to those who posed as their special pleaders. "Exhaustless forest," "forest resources scarcely scratched," have passed current even in this day as intelligent patriotism and what the sales-manager calls 'ginger talk.' Moonbeams make insecure bracing for any Reconstruction platform and the moonbeams of reckless estimates of Canada's tree farm have been not only intrinsically foolish but have acted as a standing invitation to nation-wide vandalism.

Happily the orator has been supplanted by the bookkeeper and his adding (or rather subtracting) machine. We know now that two-thirds of the forest inheritance of Canada has been swept away by fire, that in the province of British Columbia, holding half the timber of all Canada, more than twenty-two times as much timber has been given into the maw of forest conflagrations than has been used in all the British Columbia mills. Through fairly precise surveys we know now that when the prairie provinces ask for the return of their forest resources from Dominion control they are really asking for a property which, while thickly laden with excellent timber in earlier years, is now so badly wrecked by fire as to cost any government more than \$700,000 outlay annually for fire protection, with only about \$500,000 coming back in revenues. For long years to come, the prairie province forests, growing mostly on non-agricultural soils, cannot turn in a dollar of net

revenue, but must patiently be nursed back to productive condition.

### What of the Workmen?

Only when a detailed survey is made of Ontario forest lands will we know approximately the enormous robberies of timber from the public domain through the agency of forest fires. White pine, our most precious Eastern wood, is far along the road to exhaustion, showing a progressively smaller cut from year to year. This is one of the dividends of our amazing disregard for the foundations of national wealth. Here are hundreds of mills with dependent towns and populations, cut off from future sustenance by the suicidal thrust that severs a province from its vast legacy of white pine. The destructive fires continue. The old-fashioned methods of cutting with no effort to secure new growth—*butchering without breeding*—have shortened the span of life of some of the largest Ontario mills, as far as white pine is concerned, to 1921 or at most 1925. In face of these alarming facts, the first step has yet to be taken to ascertain methods of rehabilitating the white pine on areas cut over. Fortunately the carnival of forest fires in Ontario has likely seen its wildest days. A strongly organized Forest Service with over 1000 rangers and inspectors, generous expenditures on equipment and modern ideas of management, has been brought into being during the past four years. No action more creditable has been done by any Canadian government in such short time, and while it may cost half a million dollars a year it is cheap insurance. Fire protection, however, is but the first step in state supervision of public-owned forests. The interests of the province and of the lumber industry now call for a re-examination of present "regulations" in the light of modern experience, and the employment of technically trained woods managers in all cutting operations on the public domain. This may sound new; it is five hundred years old. It may sound like a fresh dose of



state interference, but only this form of state 'interference' can possibly rescue private industry from obliteration.

In Quebec, out of sheer necessity, the limit-holders have banded together to form fire protective associations. Their range of holdings now extends over 75,000 square miles, most of which may be said to be guarded by the best methods yet developed. A hydro-aeroplane may be added to Central Quebec's fire-detecting machinery next spring; the device is experimental, but great possibilities are before it.

### **Nova Scotia Still Waiting.**

New Brunswick's acceptance of state responsibility in care of its forests has resulted in an excellent organization freed from political control, with a technical forester at its head. Nova Scotia has yet to create a Provincial Forest Service, although the present condition of its timber supply and the disastrous consequences of further delay in methods of rehabilitation, render such a public department even more essential than in New Brunswick.

Because much government machinery has been brought into being for the mastery of the forest fire menace, one must not conclude that the plague is subdued. It will not be until the economic and moral senses of the population are considerably honed up by aggressive education. Fire protection, however, is merely a rudiment of forest management, corresponding to the purchase of a sprinkler system in the art of making motor cars. Each is fundamental, like good health and macadam roads. But fire protection is not sufficient to reconstitute the values in the denuded white pine or spruce forests of Ontario and Quebec. It is not alone sufficient to extend the life of the paper mills beyond the doleful "fifty years" guessed at by so many manufacturers during the recent paper inquiry. It will not arrest the persistent crowding out of the white spruce by the quickly rotting balsam, nor will it maintain the supremacy of the coniferous trees over the less important hardwoods.

This is the field of Practical Forestry. Once we have insured our forests against loss by fire, and that day is not far distance in some parts of Canada, the urgent duty of Government Forestry Departments is to proceed to constructive forestry.

### **The Ramrod Method.**

For an illustration: the Ontario lumberman in white pine tracts, usually cuts clean; in Quebec he cuts to a diameter limit. In the first instance, the areas too often grow up in valueless hard-

woods; in the second instance, the diameter restriction fails in its purpose of retaining seed trees and leaves a scattering of young trunks to be wasted by windfalls. This clearly indicates the futility of any fixed method blanketing a whole province. Nature defies ramrod regulations, for local conditions must be separately considered. In other words, logging to be carried out with respect for a future growth is a matter of constant technical supervision and can best be done by forest engineers working for the perpetual custodian, viz.: the Government.

It is supreme national folly to refrain longer from applying state authority to the utilization of the public forest possessions. If there is any other method of shielding the nation from the consequences of timber denudation, five centuries and a dozen nations have not discovered it. New Brunswick, once growing pine like wheat stalks, has now so little of the stock that lumbermen cut six logs of other species to one of pine. Is this stupid acceptance of what constitutes a commercial blow, a slashing of export trade, a closing of mills, to be allowed to run parallel to all sort of expensive national schemes for reconstruction and readjustment. A basic resource out at elbows, the foundations of our greatest industrial enterprise being kicked out stone by stone, and as yet no hand lifted to provide the obvious remedy. White pine and spruce forests can be so operated as to maintain the capital stock for all time to come. Probably no man alive can write out a formula for it like a cure for toothache. What might be an excellent method in France or New England may be altogether fantastic for the Coulonge river in Quebec. Market conditions are in themselves a prime factor in practical forestry. Each region must be considered in its special details; the best method of handling each tree species is a proper subject of experimental plots given varied treatment. This has been instituted for the purpose of spruce reproduction studies in parts of Quebec and New Brunswick by the Commission of Conservation working with the Provincial Government and commercial companies. One of the surprises brought out in the preliminary reports is that a spruce tree under present conditions does not reach twelve inches diameter inside of 175 to 200 years. Such facts only go to show the gross short-sightedness of destroying by careless cutting operations the reproductive capacity of this truly wonderful but slow-acting forest organism. What is being

done for a better knowledge of spruce reproduction does not apply to pine except for an experiment station started on the Petawawa Military Reserve by the Dominion Forestry Branch.

### Public Still Believe It.

The greatest single stumbling block in the way of forest conservation in Canada is the inherited notion of our great grandfathers that the forest is a transient, a sort of way-station between the primeval wilderness and the ultimate farm. This is fundamentally vicious. Pioneer times are over. There is very little forest, except in the Ontario and Quebec clay belts, that should be cleared for farms, for two-thirds of the whole Dominion is unfitted for agriculture. At the

same time, we have enormous areas of lands, cleared by fire or axe, that must be returned to forest. The emphasis, therefore, has shifted to the opposite scale. Restoring the forest lands, guarding existing timber from fire, regulating the axe so as to keep the forest paying rich dividends for all time to come.

Sylviculture—the art of growing repeated crops of timber on non-agricultural soils—is not an exotic in Canada. It is long-headed business sense that first came to light in the wake of exhausted virgin forests. It is frugality and caution after a night of prodigal waste. It is keen business foresight, it is love of national freedom, it is reverence for past and respect for future. But above all it is business.

## RESOLUTIONS AT THE ANNUAL MEETING C.F.A.

The following resolution urging upon the Dominion Government the placing of the Canadian National Railways under jurisdiction of the Board of Railway Commissioners so as to secure uniform fire protective methods on all railway lines of Canada was proposed by Mr. W. E. Golding, managing-director of the New Brunswick Railway Co., St. John, and carried:

“Whereas the Board of Railway Commissioners of Canada has jurisdiction over nearly all privately-owned railways in Canada, and the efficiency of the fire protective measures of such railways has been largely increased by reason thereof;

“And whereas the roads formerly known as Government Railways have not been brought under the jurisdiction of the aforesaid board, it is advisable that all such railways should be subject to the jurisdiction of such board in all matters having to do with the safety of our forests, and should be subject to the same rules and regulations regarding the fighting of forest fire hazard as may be considered necessary by the said Board of Railway Commissioners.

“That this convention places itself strongly on record in favor of having all the lines of the Canadian National Railways under control of the Board of Railway Commissioners, and of taking the necessary measures to bring this resolution to the attention of the Government, and to urge that the necessary legislation be prepared and be brought before the next session of Parliament to make the same effective.”

### Survey of Timber.

Another resolution was passed at the instance

of W. Gerard Power, President, Canadian Lumbermen's Association that:

“Whereas an accurate survey of all standing timber in Canada, showing the various kinds of lumber, the quality, location and accessibility, together with available means of transporting same to the nearest market, also a report of all cut-over lands which are suitable only for forest growth, with the extent and location of same, would be most valuable information, not only to lumber operators, but to the various Dominion and provincial governments, enabling them to develop to the full extent a permanent forest policy which would have the effect of conserving the great natural resources contained in Canada's forests;

“Be it resolved that the Canadian Forestry Association urge upon the proper governmental authorities to provide adequate financial assistance, and clothe the Commission of Conservation with the necessary authority for the purpose of accomplishing the end in view;

“Further, that the lumbermen of Canada pledge their assistance to the Commission of Conservation to this end.”

Reference to the development of a national aerial service in forest fire detection and forest mapping was made in the following resolution, which was carried:

“Resolved that the various interested departments of the Federal Government be urged to use or donate the aeroplanes and flying boats now in their hands for forest fire protection and for the estimation of the forest resources of the Dominion, and that a committee be appointed to wait upon the Militia and Marine departments to this end.”

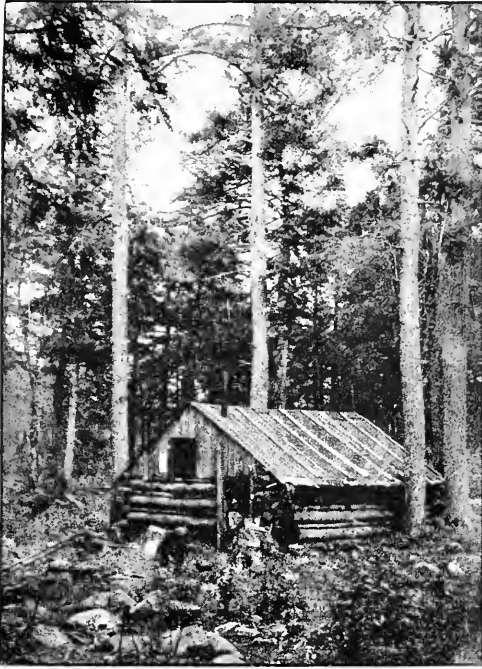

### THE HOTEL "SHANTY"

Yep, I have stayed at the fancy hotels,  
 Et off the silver an' fed off the plate,  
 Loafed in the lobby with all of the swells,  
 Rose at eleven an' hung around late.  
 Just for an outin' it maybe will do—  
 Never for me for a regular thing.  
 I belong up where the weather is blue.  
 I belong up where the little birds sing.

I've got a shanty—I'll tell you of that:  
 You may not think it much of a dump.  
 Under a pine tree it sits on a flat,  
 For the foundation one corner a stump.  
 Made it myself out of No. 2 boards,  
 Covered with paper, the tar-paper kind,  
 But not a house of the ladies or lords  
 Halfway as homelike you ever will find.

And there's a river just twenty yards down—  
 See it by day an' you hear it by night—  
 Never a fountain that plays in the town  
 Makes you in summer a prettier sight.  
 Haven't got much in the way of a lawn,  
 But there's a carpet that autumntime weaves,  
 Bright red and yellow when summer is gone,  
 Made out of needles an' grasses an' leaves.

That's the hotel that I'm hankerin' for—  
 Just a board cabin up there on the crick,  
 Settin' beside of a silvery shore  
 Up where the tamarack timber is thick.  
 You take your marble an' you take your glass,  
 You take your brass an' your copper that shine—  
 I'll take the river, the tre s an' the grass,  
 I'll take my shanty up yonder for mine!

By DOUGLAS MALLOCH,  
*The Lumberman Poet.*

### REFORESTING OLD ONTARIO. (Brockville Times).

The question of reforestation in Ontario is a paramount subject and one that should not be left in abeyance. We have always advocated a definite plan and vigorous action in the premises. The matter has of late received very small attention on the part of those charged with provincial business. It is true that the war so occupied the time of Parliament that other subjects, no matter how pressing, were made in a way subsidiary. Of that no person can seriously complain. Now that the war is over, reforestation should occupy its prime position.

The Belleville Ontario in the subjoined article states the case for Hastings County and the reasoning enunciated applies with equal force to Leeds and Grenville. Says it:—

"There is pressing need of renewing the forests of Ontario in the older portions. Although it is some forty years since the first Ontario forestry official was appointed, the work has only been carried on intermittently and the startling statement is made that if older Ontario were cut off from outside sources of fuel supply the people living in these parts would be faced by two alternatives, a wholesale exodus or freezing to death. This may be confirmed by personal observation in this part of Ontario. There are various reasons why an energetic forestry policy should be entered upon. Amongst these are protection against the blasting winds, conservation of the water supply, and fuel needs. There are many waste places in Hastings County which have been cleared and are unprofitable for the growth of anything but trees and this would be a favourable time for entering upon an energetic policy of reforestation. The return of the soldiers would at least make this a very favorable time for engaging in most vigorous reforestry work."



The Canadian Forestry Association's Coach which toured four provinces in 1918. A larger and more fully equipped coach will be sent out early in the present year. A stop is made at all communities in the neighborhood of timber. By liberal advertising in advance, large crowds visited the coach. In the evening, a motion picture lecture was usually given at a local hall. This enterprise was conducted by the Association under an arrangement by which the railways furnished free haulage.

## A HIGHER STANDARD FOR FIRE RANGERS.

Prince Albert, January 20.

In order that the Dominion of Canada may recover from the financial strain, which the burden of war has imposed, it will be necessary to develop the latent resources of the Dominion much more rapidly than would otherwise have been found necessary.

Canada is faced with a debt of approximately one and a half billion dollars, and an annual budget of three hundred and fifty millions, to be met with increased taxation. It is therefore evident that we must guard and protect our natural resources from devastation if we are going to meet our liabilities and reap the full harvest in revenue from this source of our income. The development of our timber resources will play a prominent part in assisting to settle our indebtedness. The revenue, however, derived from this natural product will depend to a considerable extent on fire protection. It has been estimated that the amount of timber destroyed by fire in Canada, is ten times that which has been taken out by lumbermen. It is with particular reference to the protection of our timber from destruction by fire that I wish to deal. The colossal devastation of the past is now a matter of history, which indicates that in those days we did not fully appreciate our heritage, and it is questionable today whether we have benefited from this experience, and are fully prepared to meet this demon of the forest in such a manner that forest fires will become a thing of the past.

### The Temporary Ranger.

The policy followed during this war was "conservation of our resources," if we were to meet with ultimate success; wanton waste was considered a criminal offense. Therefore it is no longer necessary to adopt the apologetic attitude in asking for the recognition of fire protection, and such legislation that will bring the careless setting out of clearing fires under the same category as Arson. The enactment of suitable laws however, will not furnish the desired protection, unless provision is made for the necessary machinery to administer the law. In these days of reconstruction and evolution, would it not be wise policy to take stock and overhaul our fire protection organization to meet the future developments and the advance of more modern methods? The average fire ranger is a temporary employee, engaged for the summer months, with few opportunities of advancement,

and discarded in the fall. Employment under the above conditions naturally does not attract men of a progressive mind, or encourage these men to take the desired interest in the work, which is so essential to the success of any organization. The average area allotted to each fire ranger is large enough to warrant retaining his services permanently, figured on the basis of fire insurance, according to the value of the stand of timber he is protecting. The modern Fire Ranger is a member of a new profession, demanding practical experience and technical knowledge of many engineering sciences, ability to command men and to enforce the law and enlist public co-operation. Men with the above necessary qualifications will not accept employment of a temporary nature. The engaging of Fire Rangers during the summer months or for the danger period, is not a progressive policy. The very foundation of fire prevention can be better established during the winter, when climatic condition allow him the necessary time to devote his attention to the educational part of the work. He should be capable of giving illustrated lectures on fire protection at the various schools adjacent to his district. He should visit each individual settler, impress upon him the importance of fire protection and where a settler intends clearing a portion of his land in the spring, he should draw up a plan of action whereby fire will not escape from such burning. Therefore our policy in future should be the engaging of intelligent Fire Rangers on a permanent basis.

THOS. McNAUGHTON,  
Divisional Fire Inspector, B.R.C.

Two-thirds of the entire area of Canada is non-agricultural.

Seventy per cent. of Nova Scotia and New Brunswick is natural forest-growing land and will not pay a profit to the farmer.

The forests of France, so carefully protected and cultivated for centuries, saved the cause for the Allies. More than 40,000 trees a day were cut during four years to meet the demands of the military leaders.

The Dominion Government's Forestry Branch has planted more than 40,000,000 trees on the prairies and 85 per cent. of them are thriving to-day.

# WORLD DEMAND SHORTENS LIFE OF OUR FORESTS

*By F. J. Campbell, President, Canadian Pulp and Paper Association,  
in an Address at Annual Meeting Canadian Forestry  
Association, Montreal, January 29th.*

## Has Quebec Enough Pulpwood to Last Longer Than 22 Years? A Vital Industrial Problem.

The question of the relationship of our industry to the maintenance of forest material is of such very great importance that I appreciate it a privilege to put a few figures before you and leave you to do your own thinking about them.

It is estimated that the standing pulpwood in the Province of Quebec at the present time amounts to 300,000,000 cords, but the best authorities agree that this is little better than an average of guesses and until such time as we have a comprehensive stock-taking our estimates are of questionable value.

Eliminating what is being burned and otherwise destroyed, what is being opened up to settlement and cut for lumber and deducting what is absolutely inaccessible and what is commercially inaccessible, my own guess is that the available supply of pulpwood is about one half of the amount mentioned, or 150,000,000 cords. This is borne out by a review of the estimate made in 1904 by Mr. J. C. Langelier, Inspector of Forest Rangers for the Province of Quebec. At that time Mr. Langelier estimated the available supply of pulpwood as 176,783,966 cords and the consumption at that time as 526,865 cords per annum and he estimated that at the then prevailing rate of consumption, our forest supply in the Province of Quebec would last over 334 years. This was just fifteen years ago.

The consumption of pulpwood cut in this province in the year 1916, the latest complete figures available, amount to 1,711,151 cords, which is  $3\frac{1}{4}$  times that of 1904.

During those twelve years we had cut approximately  $13\frac{1}{2}$  million cords, reducing the available supply based on Mr. Langelier's figures to approximately 163 million cords. Thus three years ago Mr. Langelier's figures came within 13 million cords of my present guess.

Basing an estimate in the same manner as that employed by Mr. Langelier and dividing our current consumption in 1916 of 1,711,000 cords

into available supply of 163,000,000 cords, we find that instead of having 334 years' supply, less twelve that have passed, or 322 years ahead of us, and making no allowances for further increase, our supply based on consumption in 1916 would last just 95 years; a wonderful difference in the course of twelve years.

We have seen that in twelve years our cut has increased  $3\frac{1}{4}\%$ , and we might perhaps base the future consumption as increasing at the same ratio but so as to be on the safe side let us consider that the increase during the next twelve years will be in direct ratio to that of the previous twelve years, in which case our consumption in 1928 will be at the rate of three million cords and we shall have used by that time 28 million cords, bringing down our available supply to 135 million cords.

Again basing the future supply on the consumption of three million cords per annum, which we shall then have reached, the available supply will be sufficient for 45 years more, providing the consumption shows no further increase.

When we consider that in the space of 24 years, owing to increased consumption, our expectancy of supply has dwindled from 334 years to 45 years, the figures appear almost incredible.

Even if we take the figures of our available supply as entirely hypothetical the extraordinary growth of our consumption still gives us ground for serious thought. Whatever the supply, we know that it is not increasing, while the consumption is growing rapidly, not steadily but with astounding rapidity.

The fact remains that with a given supply, whether right or wrong, 24 from 334 leaves, not 310 but 45—a startling difference.

It may be questioned as to whether we are justified in looking for the increase in consumption on which these figures are based. As a matter of fact, I think we may count that they are under the mark.

Prior to the establishment of the Dominion Forestry Branch, figures as to the cutting of pulpwood are indefinite but a glance at the growth of the pulp and paper industry in Canada will be illuminative.

It is only a comparatively few years since nearly the whole of the pulp and paper industry on this continent was South of the Great Lakes. It then developed in this province to the south of the St. Lawrence. Since then it has been extended on a much larger scale to the north of the St. Lawrence, and already very large plants have been erected far to the north; as the supply of wood in the United States disappears the mills dependent on it are being replaced by mills in this country.

We must therefore count not only on the natural increase in the consumption of paper but also on the rapid centering of the pulp and paper industry in this country and largely in this province (Quebec), owing to our present supply of wood and ample water-power.

In the year 1890 the value of the output of the pulp and paper industry in Canada was \$3,633,257; in the year 1915 this output had grown to \$40,348,021; in 25 years it has become 11 times greater than it was. The figures I have mentioned regarding our wood supply allow for an increased consumption that in 24 years or in the year 1928, only 9 years ahead, will be  $5\frac{1}{2}$  times greater than in 1904, but it is probable that at the prevailing rate of development the consumption will be at least  $3\frac{1}{4}$  times that of 1916, ten times greater than in 1904, or  $5\frac{1}{2}$  million cords per annum. At that rate the remaining supply would be about 121 million cords or, without allowing for further increase, sufficient only for 22 years more.

Dr. Howe tells us our cut over forests are changing from coniferous to deciduous trees.

It is to be hoped that the Government, without loss of time, will provide means to amplify this study, as well as to seek a remedy for the loss from insects and fungi.

Large areas are still being burned, though improved methods of fire fighting and the awakened interest of the public are beginning to be effective in the reduction of this waste.

The need of re-growth and re-forestation is plainly apparent. In this respect it does seem as though returned soldiers might be employed to advantage in the planting of trees. We all know the difficulty the soldier finds in readjusting himself to the routine of civil life, but this work could be carried out under conditions not dissimilar to those of the army life. The men

would be usefully employed and their work would some day be splendidly profitable.

---

### BARGAINS IN NATURE BOOKS..

By a special arrangement with the publishers, the Canadian Forestry Journal is able to offer its readers the following standard books at advantageous prices:

**The Tree Guide.** (Trees East of the Rockies), by Julia Ellen Rogers. Published by Doubleday, Page and Co. Made to fit the pocket, 265 pages, photogravures on every page, 32 pictures in full color. A beautiful and authoritative work certain to please you. In leatherette binding; gold lettering. Price \$1.10 postpaid.

**The Animal Guide,** covering all North American wild animals. 250 pages, with sixty species of animals in natural colors; pocket size. Entertaining in text and illustrations. Written by a noted authority, Chas. K. Reed. Genuine leather, \$1.00 postpaid.

**North American Game Birds,** by Chas. A. Reed. 65 pages, each containing a splendidly life-like illustration in four colors. Board covers. Price 50 cents postpaid.

Remit by stamps, money order or cheque, adding ten cents to latter for collection, to Canadian Forestry Journal, 206-7 Booth Building, Ottawa.

---

### CAMPBELL'S POLL AXE.

Lumbermen often find it difficult to get steel poll axes which stand hard usage in driving saw or tree wedges. Messrs. Campbell Bros., St. John, N.B., have invented an axe which, as will be seen by their advertisement in this issue, is under a specific guarantee to be "the best tool made for driving wedges, bolts, etc." The Poll Axe is made with a piece of  $1\frac{3}{4}$ " best cast steel fitted and welded solidly into the poll of the axe. It cannot come apart or break as it is properly welded and tempered, and will not flatten out, as is generally the case with the old style of axe having a thin piece of inferior steel welded on the poll. This axe contains the durability and cutting qualities that have made "XXX" Tools famous. It has a thin keen edge and will balance perfectly on the handle and will chop easier than a light poll axe.

## FOR SALE—CHOICE TIMBER TRACTS

One or both; located on Columbia River and Tributaries north of Revelstoke, British Columbia; twice cruised by Marwick, Mitchell, Peat & Co., New York; surveyed by Christie, Hayward & Dawson, Vancouver, B.C.; near interior market; saving in freight over coast shipments two dollars thousand. Do you want high class timber property, if so write

S. A. HOLBROOK, Bradford, Pa., "Owner."

### TIMBER IN M. FEET

| TRACT             | CEDAR       | SPRUCE      | FIR        | PINE       | HEMLOCK                 | TOTAL       | CEDAR<br>POLES |
|-------------------|-------------|-------------|------------|------------|-------------------------|-------------|----------------|
| Downie Creek..... | 204,143,000 | 47,228,000  | 18,186,000 | 7,473,000  | 79,748,000              | 356,778,000 | 60,612         |
| 16 mile .....     | 54,002,000  | 30,687,000  | 2,433,000  | 1,758,000  | 21,012,000              | 109,892,000 | 21,625         |
| 25 mile .....     | 67,468,000  | 39,908,000  | 28,799,000 | 5,068,000  | 47,086,000              | 188,332,000 | 27,642         |
| Goldstream .....  | 33,649,000  | 16,406,000  | 478,000    | 200,000    | 7,577,000               | 58,310,000  | 8,857          |
| 50 mile .....     | 45,890,000  | 34,395,000  | 6,050,000  | 1,155,000  | 20,095,000              | 107,585,000 | 35,360         |
| Schoonmaker ..... | 2,785,000   | 10,851,000  | 1,348,000  |            | 4,108,000               | 19,090,000  | 2,116          |
| (83 miles)        | 407,936,000 | 179,475,000 | 57,294,000 | 15,654,000 | 179,629,000             | 839,988,000 | 156,212        |
|                   |             |             |            |            | Dead and down cedar.... | 25,217,000  |                |
|                   |             |             |            |            |                         | 865,205,000 |                |

### S. A. HOLBROOK (Trustee) TRACTS.

| TRACT         | CEDAR       | SPRUCE      | FIR        | PINE       | HEMLOCK    | TOTAL       | CEDAR<br>POLES |
|---------------|-------------|-------------|------------|------------|------------|-------------|----------------|
| Gaffney ..... | 57,433,000  | 35,534,000  | 15,653,000 | 3,409,000  | 10,168,000 | 122,197,000 | 84,062         |
| 22 mile ..... | 60,880,000  | 67,425,000  | 28,951,000 | 8,233,000  | 74,131,000 | 239,622,000 | 32,569         |
| (34 miles)    | 112,313,000 | 102,959,000 | 44,604,000 | 11,642,000 | 84,299,000 | 361,619,000 | 116,631        |

**FOR BIGGER  
AND BETTER CROPS**

**STEELE, BRIGGS'  
SEEDS**

**SOLD EVERYWHERE IN CANADA**  
*WRITE FOR NEW CATALOG*

**STEELE, BRIGGS SEED CO.**  
"CANADA'S GREATEST SEED HOUSE" LIMITED

**TORONTO**  
HAMILTON WINNIPEG

## A YEAR OF PROPAGANDA

### The Canadian Forestry Association's Enterprises During 1918 Passed in Brief Review.

*Editor's Note: The following constitutes the report of the Directors of the Canadian Forestry Association regarding the work of the past year.*

In the following report it will be seen that whereas in 1917 many new ventures were entered upon the extension of services in 1918 has been marked. There has been a constant endeavor to hold the Association in the part of practical utility, and as in previous years so in 1918 the bulk of effort has been given to the promotion of forest fire prevention. While this is no more than a rudiment of the forestry programme to which the Association has been committed, it is of such importance as to justify our maximum effort for many years to come. We have been occupied during the past twelve months with two main forms of propaganda, direct campaigns with governments for changes in laws or organization and educational work directed towards those districts and classes of population most requiring our services. After some months of delay, owing to difficulties with the Canadian Railway War Board, a railway coach was loaned to the Association by the kindness of the Canadian Pacific Railway Company for the purpose of providing a travelling demonstration of the importance of modern forest protection. The car was outfitted at Ottawa about the end of August with models of lookout towers, an aeroplane, forest telephones, a Marconi wireless set, a miniature nursery, sets of industrial exhibits, showing the process of paper and other manufacture, and samples of Canadian woods. This was supplemented by a large quantity of educative literature in English and French, as well as souvenirs reinforcing the fire prevention idea. The Secretary took the car from Ottawa through a section of Ontario and Quebec as far as Smooth Rock Falls in the Ontario Claybelt. Through the kindness of the Quebec Forest Service we were permitted the services of Mr. Victor Baillaigé, who held a series of meetings from Cochrane to Edmundston, N.B. The car was covered with large banners asking the public to take precautions in preventing timber destruction. So popular did the coach prove that bodies of visitors sometimes reaching 600 in a single day, came aboard, inspected the exhibits, heard the explanations

as to the methods of fire prevention, the importance of the forest industries and their raw materials and as much other information as could be given them in the brief time allowed. Usually a motion picture lecture was given in the evening so that occasionally we reached as many as 700 to 800 people in the 24 hours. At the New Brunswick border the car was met by a representative of the New Brunswick Forest Service and taken to those points where educational work was believed to be most necessary. At the Nova Scotia border the Secretary of the Canadian Forestry Association again met the car and took it to eastern and western Nova Scotia. Two or three of the Nova Scotia engagements had to be postponed on account of the prevalence of influenza, but at the eight points where public meetings were held the attendance was remarkably good. On the western trip from Nova Scotia to Quebec the exhibition car was wrecked at Springhill Junction and had to be taken to Moncton. There a new car was secured from the Canadian Government Railways but could not be employed to finish our schedule in the Lake St. John region because of the ban on all public meetings caused by the epidemic. The Association hopes to secure a larger and better car for the 1919 season and to multiply the exhibits. It is not too much to say that the use of the car proved one of the most effective steps yet taken in forest protection propaganda. The response on the part of the public amply justifies proceeding with the scheme along more extensive lines in 1919.

#### **Reaching the Children.**

Early in the year a series of school teachers' announcements was prepared and sent to the Governments of British Columbia, Ontario, Quebec, New Brunswick and Nova Scotia. By cooperation of these governments a great multitude of school children was warned as to the danger of forest fires and given instruction as to how to prevent them. In most cases the department of education joined with the minister in charge of forests in circularizing all school teachers and sending them copies of the Forestry Association's literature to be read to the children. These





## FOREST TELEPHONES

Make the life of the forester better worth living. They relieve him from the appalling loneliness. They help him to keep in human voice touch with foresters miles away.

In emergencies—fire—sickness—hunger—the speed with which they can summon help is marvellous.

Write for full particulars of how to install the Northern Electric Forest Telephone System. Address the Office nearest you.

**Northern Electric Company**  
LIMITED

|          |          |           |
|----------|----------|-----------|
| Montreal | Toronto  | Regina    |
| Halifax  | London   | Calgary   |
| Ottawa   | Winnipeg | Vancouver |

***Northern · Electric · Forest · Telephones ·***

## RESERVES FOR FUTURE POPULATION.

Note how the chief nations of Europe have retained as timber reserves percentages of their total area far in excess of any of the Prairie Provinces of Canada.

### IN THE FOREST RESERVES OF WESTERN CANADA.

|                                | Percentage of<br>total area. | Population per<br>square mile | Percentage of<br>total area in<br>permanent<br>forest. |
|--------------------------------|------------------------------|-------------------------------|--|
| Alberta ----- 16,711,776 acres | 14.00                        |                               |  |
| Saskatchewan_ 6,197,707 acres  | 3.97                         |                               |  |
| Manitoba ----- 2,606,400 acres | 1.75                         |                               |  |
| Belgium -----                  |                              | 652.                          | 18.3   |
| France -----                   |                              | 189.5                         | 18.7   |
| Germany -----                  |                              | 310.4                         | 25.9   |
| Switzerland -----              |                              | 234.8                         | 22.7   |
| Sweden -----                   |                              | 32.4                          | 47.8   |
| Russia in Europe ---           |                              | 64.6                          | 31.0   |

The reader will keep in view that two-thirds of the whole area of Canada is totally unfit for agriculture and that the percentage of non-agricultural land now in forest reserves in the prairie provinces is a very small fraction of what is adapted by nature for timber growing purposes.

With exception of a few localities such as the Ontario Claybelt, the pioneer's problem of reclaiming land from the forest has become a new problem of reclaiming land for the forest.

There is much more land stripped of forest that should be reforested than there is land under forest that should be cleared for agriculture.

periodic warnings and talks to school children on forest fires have become a regular part of the Association's campaign.

To head off the forest fire season by winning public co-operation, an effort was made to develop an interest in a national advertising plan, with the result that the Governments of Quebec, Ontario and New Brunswick consented to subscribe \$2,000, 1,000, and \$600 respectively, to be supplemented by \$6,400 from the Dominion treasury. With the assistance of Messrs. A. McKim of Montreal, a very complete plan was built up whereby the newspaper-reading public from coast to coast would be appealed to month after month with graphic messages along the lines of fire prevention. We were unable to secure the final endorsement of the Dominion Government in this matter, but the ground work has been already done, and there are reasonably good prospects of achieving our end in the early part of 1919.

#### **Preparing Propaganda.**

In no year has the Association prepared and issued such a quantity of educative literature. To assist the work of the rangers in the three prairie provinces, 15,000 booklets with colored illustrations were prepared, each province being treated separately. 20,000 copies of "A Partnership Offer" which demonstrated to the reader the identity of interest between the ordinary citizen and the Forests, were given circulation in New Brunswick and Nova Scotia. 10,000 copies of "Petit Catechisme de la Foret," which took up the rudimentary questions commonly asked by children as to the work of rangers, the ownership of the forest resources, etc., were sent out through the Forest Protective Association and other agencies in Quebec. A duplicate edition of 10,000 copies entitled "The Child's Book of the Forest" was prepared for special issue in Ontario. Three issues of the Bulletin de Foret and the Forest Bulletin were sent out in English and French to thousands of rangers, clergymen and others through Ontario and Quebec. 12,000 copies of "The Forests of Canada in Peace and War," which related the cause of conservation in the Dominion to the interests of the British Empire, were given careful circulation throughout Canada. 3,000 copies of "The Case for Nova Scotia's Forests" were distributed in the Province of Nova Scotia, and have proved a valuable basis for our campaign in this province. The foregoing illustrate some of the leading pieces of publicity which have been used in 1918.

#### **Five Lecturers at Work.**

Unable through the limitation of its own finances to engage lecturers for special work, the Association was fortunate in securing the co-operation of the Quebec Forest Service and of the Dominion Forestry Branch in providing excellent propagandists for services in the French speaking districts of Quebec and New Brunswick. Mr. J. A. Doucet of the Dominion Forestry Branch was allowed by the Director of Forestry to proceed to New Brunswick where, in the month of May, he delivered 15 lectures, usually before large audiences. This was the first educational work yet accomplished in the French speaking communities of Northern New Brunswick along lines of forest protection and the cause of forestry. Newspaper and other reports of Mr. Doucet's work plainly show that such services were very much needed, and when tactfully carried out were much welcomed by the French-speaking communities. The Association engaged Mr. A. H. Beaubien for three weeks' work in the territory of the Ottawa River Forest Protective Association. He managed to cover very thoroughly the outlying parishes on the northern part of the Mont Laurier division in Quebec and the section of worst fire hazard along the Maniwaki division. The response to Mr. Beaubien's efforts is worthy of more than passing notice, inasmuch as at several places audiences of 300 and 400 persons, many of whom had travelled long distances, listened with close attention to the story of forest protection and, without doubt, have today a more intelligent realization of their personal responsibility. About the first of June Mr. Piché permitted two of his technical staff, Messrs. Baillargé and Tessier, to engage in lecture work in the Lake St. John region and through the territory of the St. Maurice Forest Protective Association. In all of this work the Forestry Association supplied plenty of advertising matter, entered into arrangements with local authorities, and was responsible for the provision of the lecture equipment. The fact that both of these lecturers were given favorable receptions in all the parishes visited and at the same time were obliged to antidote a great deal of misconception and prejudice in regard to the work of the fire rangers and the public value of the forest industries emphasizes the necessity for intensifying the educational effort through these and other sections of Quebec. During the year 1918, therefore, five lecturers conducted series of public meetings under the auspices of the Canadian

Peterborough Canvas Covered and Wooden Canoes are built in all sizes and for all purposes. For Pleasure, Cruising, Trapping or Freighting.

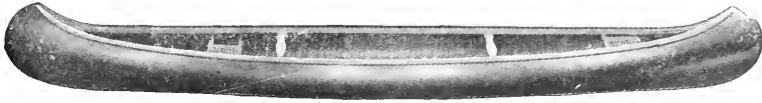

Peterborough Motor Boats, like the Canoes, are built in all sizes and for all purposes. If you are interested we will send you our illustrated Catalogue.

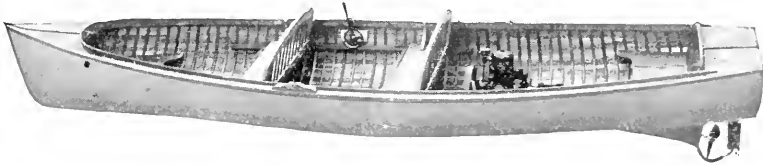

This Trade Mark appears on all genuine Peterborough Craft.

THE PETERBOROUGH CANOE CO. LIMITED  
Peterborough, Ontario, Canada

# FORESTERS!

We want you to know  
all about our

“ARCTIC EIDERDOWN  
SLEEPING ROBES”

It is to your own personal interest and  
comfort to own an Arctic Robe.

—Manufactured only by—

WOODS MFG. CO. LIMITED  
OTTAWA

“Booklets Ready for Mailing.”



Forestry Association, although the greater part of the financial maintenance of three of them was borne by the Quebec Forest Service and the Dominion Forestry Branch.

A total of 150 public meetings were held between Spring and Fall on the subject of forest protection. This is about three times the average number in previous years.

#### Use of Lantern Slides.

Audiences at motion picture theatres are susceptible to appeals on forest protection matters and this avenue has been utilized by obtaining the co-operation of theatres in most of the forested districts across the Dominion. A weekly service of lantern-slide cartoons and printed appeals were set in operation last Spring and continued until the Fall months. Local reports declare that the slides were well emences. Most theatre managers have agreed to played and were happily received by the audi-carry out the plan in 1919 as well.

Motion pictures are now a regular part of the Association's lecture equipment and some of our films have been made use of in circuits of motion picture theatres.

#### Tobacco Company's Help.

Of several pieces of educational work of a like nature, we might mention particularly the arrangement made with the Imperial Tobacco Company, Montreal, through the courtesy of Sir Mortimer Davis, to place in the cigarette packages sold through Canada a series of printed slips, asking the smoker to extinguish match and cigarette before throwing away.

Our school lecture sets, which now number five, were in active employment during the first part of the year. The closing of schools and

the need of crowding the curriculum to make up for lost time made it necessary for us to withdraw the service partly during the fall months. These sets are again in operation and with their fifty colored lantern slides and lecturer's manuscript have proved a popular plan of reaching schools and churches.

In the spring months forty school boards or private citizens used these sets in their localities, often employing the equipment night after night as in Hamilton and London, to reach all the local teachers and children.

#### Western Lectures.

Owing to the distance from Ottawa the travelling sets have not been available to the prairie provinces or British Columbia. This has now been overcome by stationing at the Western offices of the Dominion Forestry Branch and at Vancouver, special travelling outfits so that applications from local speakers can be filled with minimum of delay and cost for expressage.

It is well realised that the Association's efforts to develop educative enterprises in combatting forest fires cannot be fully effective unless co-ordinated with the proper machinery of law and administration. This has rendered necessary two chief campaigns of more or less intensive nature, one in Alberta to secure a Forest Protection Act, the other in Nova Scotia to have a Provincial Forester appointed.

#### Campaign in Alberta.

Through our members in Alberta, with the aid of the newspapers, Boards of Trade and other public bodies, we brought forcibly to the attention of the Government the inconsistency and danger of the present freedom in setting fires in

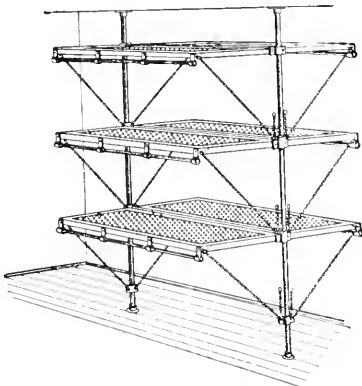

## STEEL BUNKS FOR CAMPS

Included in the well-known line of DENNISTEEL factory, hospital, camp and ship equipment is the all-steel sanitary bunk illustrated. Take up very little room, are comfortable, hygienic and practically indestructible—a permanent investment. Write for particulars and folders on any of the following lines: Steel Lockers, Bins, Cabinets, Chairs, Stools, Etc. Standardized Steel Shelving (knock-down system), Steel Hospital Equipment, General Builders' Iron-work. Ornamental Bronze, Iron and Wirework. Wirework of every description.

**THE DENNIS WIRE AND IRON  
WORKS CO. LIMITED**

LONDON  
CANADA

HALIFAX    MONTREAL    OTTAWA    TORONTO  
WINNIPEG    VANCOUVER

aid of the Director of Forestry were able to lay and near forest covered lands, and with the before the Government a draft Act. This was temporarily edged out by a mass of other legislation. We persisted in our efforts through the press and otherwise and are now informed that at the time of writing this report the Alberta Government has the Act under discussion. If the new Act passes the Alberta Legislature, the three prairie provinces will then have similar measures aimed at lessening forest losses. In each province the Association labored continuously to secure these laws.

#### A Nova Scotia Enterprise.

The Nova Scotia situation called for a great deal of 'spade work' and indeed will yet require much constructive educational effort before the Government is ready to agree with us that a Provincial Forester is an unpostponable necessity. In October, following a newspaper campaign, the Secretary held eight public meetings

at Nova Scotia points, reaching large audiences and distributing everywhere the Association's literature on provincial forest problems. Three special publications were issued: "A Partnership Offer," "Nova Scotia's Stake in Forest Protection," and "The Case for Nova Scotia's Forests," and these were circulated carefully. Every Board of Trade in the Province was communicated with and many of the more important ones responded heartily, asking the Government to put through the appointment of the Forester and organize fire prevention work on a modern basis. All provincial newspapers and weeklies were covered repeatedly and gave us generous aid. A provincial conference on forest problems was held at Halifax on December 10th, at which forty persons representative of industries and as private citizens were present. A detailed discussion of the serious situation in forest depletion now facing the province took place and the Commissioner of Lands, Hon. O. T. Daniels,

## Lumbermen

Here is something you need. An AXE and HAMMER combined. The poll or head of Axe is made of the highest grade of octagon cast steel, inserted and welded as shown. It is then properly tempered and will stand heavy driving and rough use of any kind.

Eastern lumbermen are using this Axe entirely for chopping and driving Tree Wedges. Write us for prices and further particulars.

## Campbell Bros.

ST. JOHN, N.B.

· SOLE MAKERS

XXX Chopper and Edge Tools.



Patented July 1915.

## TREES, SHRUBS and SEEDS

Hardy Northern Trees and Shrubs at Lowest Prices. Native and Foreign Tree Seeds.

### EDYE-DE-HURST & SON, DENNYHURST

Shippers to U.M. Government, Etc.  
DRYDEN, ONT. Correspondence Francaise.

## Hill's Seedlings & Transplants

ALSO Tree Seeds for Reforesting. Best for over half a century. Immense stock of leading hardy sorts at low prices. Write for price list and mention this magazine. Forest Planters Guide Free.

**The D. HILL NURSERY CO.** Evergreen Specialists  
Largest Growers in America.  
Box 503. DUNDEE, Ill., U.S.A.

## Try This Stump Puller at Our Risk

The Smith Stump Puller will take out every tree and stump by the roots, clearing from one to three acres a day, doing the work of twenty men. We want you to send for our 3 year guarantee against breakage and our free trial proposition. Address  
**W. Smith Grubber Co.**  
11 Smith Sta.  
LaCrescent, Minn.



## GAGNON & MORISSETTE

TIMBERLAND CRUISERS  
LUMBER CONTRACTORS  
FOREST INDUSTRIES

CHICOUTIMI, - - P.Q.

## LT.-COL. L. J. D. MARQUIS

Forest Engineer and Mem. Can. Soc. of F.E.;  
Quebec Assoc. of F.E.; Former  
Mem. Que. F. Service

Timber Factors and Logging Costs  
Facts on Forest Growth and Future Products  
Forest Cruising and Mapping  
90 LOCKWELL AVENUE - - QUEBEC

## Timber Lands Bought & Sold

Timber and Pulp Wood Estimates.

### R. R. BRADLEY

CONSULTING FORESTER  
Globe-Atlantic Bldg. - ST. JOHN. N.B.

ASK



FOR



## Timber Estimating & Mapping

Management of Forest Properties.  
Supervision of Lumbering Operations.  
Forest Planting.

### COOLIDGE & CARLISLE

FOREST ENGINEERS  
BANGOR - - - - - MAINE.

# Timber Estimates

JAMES W. SEWALL

Old Town, Maine.

who was present, was requested to apply the only reasonable remedy by the engagement of a Forester with a free hand to bring up the provincial forest service to a more efficient standard. The Commissioner offered a counter proposition that the conference should show him where new revenues could be obtained to support the new office. The financial aspect of the proposed appointment constituted a temporary impasse, which failed, however, to discourage the conference or abate its determination. Mr. F. C. Whitman, former president of the Association, who acted as chairman, was authorized to proceed with the organization of public opinion through forming a provincial committee. This body will endeavor to find a solution for the financial problem involved, and as soon as possible the Forestry Association and its Nova Scotia members and friends will renew its appeal to the Government.

In the important question of Civil Service Reform, particularly as it affected the field staff of the Dominion Forestry Branch, the Association took an active part. A series of newspaper articles was supplemented by a score of letters to members of Parliament, many of which evoked promises of support. After many years of attack upon the political patronage system in public appointments, it was a satisfaction to witness its final downfall and the institution of a merit system.

#### **Advancing the Journal.**

Although the Forestry Journal was one of the Association's first weapons in developing public sentiment, it is felt that the influence of this modest publication throughout Canada can again bear emphasis. It acts as a clearing house of information respecting the progress of forestry and forest protection. It has attempted to bring the layman into intelligent touch with the national aspects of conservation, the public significance of experimental and research work, the forestry movements in other lands and particularly as affects the interests of the British Empire. Monthly circulation is now over 8,000.

Commencing with the January, 1919 issue, the Journal takes another step forward in that it will be printed on heavy coated paper throughout, with illustrations much improved and a new standard of contents involving special articles on subjects of popular interest by writers of special qualification.

While the improved Journal will demand more time for editorial preparation and greater expense in production, it is believed that these

advances offer our only hope for making the magazine self-sustaining through advertising patronage, and more effective as a means of developing membership.

#### **8,000 Members Now.**

The year 1918 was peculiarly adverse for membership growth. The earlier months were filled with menacing war news, and this gave way at midsummer to a changed tide of events which quite as markedly diverted public attention from purely national and civil matters such as the upbuilding of a Forestry Association. The influenza epidemic, in the fall months, again dampened the hope of lifting the membership strength to the goal of expectation. The later months of the year proved more responsive, so that which much of the earlier work on membership was neutralized, we end the year with a clear increase of two thousand members. This gives us a total of 8,000 on our strength, as compared with 2,900 at the commencement of the war.

The finances of the Association are in good shape, with a surplus of \$919.91. Total receipts for the year were \$15,270.56, with expenditures of \$14,350.65. The common difficulties of obtaining money during war time were constantly encountered. Private subscribers, chiefly pulp and paper and lumber companies, who had been given plenty of opportunity to investigate the Association's work came to our aid to the extent of \$3,750. We have had the satisfaction of seeing many firms doubling or otherwise increasing their previous subscriptions. It is but fitting that the thanks of the Association to these loyal supporters should be expressed at this meeting.

Fortified by the expressions of confidence on the part of the limit holders, the Secretary approached the Ontario Government and by the aid of a small deputation secured from the Minister of Lands, Forests and Mines, an undertaking to increase the Association's grant from \$300 to \$1,000 in future. Similarly the Dominion Government was asked to advance our 1918 grant of \$3,000 to \$4,000, and this was done. New Brunswick also granted us \$200 this year.

The Association had occasion to realize at many junctures the deep concern and helpful attitude of the President, Col. J. S. Dennis. Exacting war duties in the United States and later in Siberia prevented the personal contact which otherwise would have been afforded, but this did not interfere with such positive forms of assistance as was involved in obtaining the Railway Exhibition Car from the Canadian Pacific Railway free of all charges.

### A Western Secretary.

Under the realization that the needs of the Forestry Association's educational work in the prairie provinces and British Columbia is quite as pronounced as in Eastern Canada, efforts were made by the Secretary to sound out British Columbia opinion on the question of appointing a resident secretary of the Association in that province. The advice of several of the western directors was sought in this matter and the project received hearty approval. With only one executive officer for the Dominion, the geographical difficulties alone have been sufficient to prevent his carrying out any intensive educational effort west of Ontario. An appeal was made to the Government of British Columbia for financial assistance and we are yet to receive a definite reply. Inasmuch as several of the larger British Columbia wood-using industries have consented to contribute an annual amount for the up-keep of a resident secretary, we feel we are justified in continuing our efforts so as to secure the sum of four or five thousand dollars

yearly to put our educational work in British Columbia and Alberta on a proper footing.

### New Tasks in Ontario.

In addition to the several uncompleted projects carried over from 1918, the Association may well consider the advisability of initiating a campaign to secure the extension of authority of the Ontario Forest Service so as to provide for technical supervision of cutting operations on licensed lands.

A similar opportunity to perform a public service is to be found in the present anomaly by which the cutting operations on the licensed timber berths in the prairie provinces and on the railway belt of British Columbia, outside the Reserves, have no technical forestry supervision whatever. This fault may be remedied very effectively and simply by extending the jurisdiction of the Dominion Forestry Branch to For many years this step has been urged by this Association and by the Commission of Conservation.

## THE FOREST CONFERENCE AT MONTREAL.

A Forest Conference, under the auspices of the Canadian Forestry Association, the Quebec Forest Protective Association, and the Woodlands Section of the Canadian Pulp and Paper Association, was held at the Windsor Hotel, Montreal, Wednesday and Thursday, January 29th and 30th. The attendance surpassed that of former years, the meeting hall being well filled during the greater part of the conference.

As has been noted in the conferences of previous years, the effect of these annual gatherings, with their stimulating personal contact and the threshing out of progressive ideas, cannot be compressed into cold statistics. One requires no better comment than that of two 'hard-headed' lumber company presidents that they were going to pay the expenses of their woods foremen to the Montreal meetings of 1920. Several executive officers of large companies who had not attended previous conferences were on hand this year, at the request of their managements. From these indications, one may judge that the annual Forest Conference at Montreal is having a pronounced effect upon those seriously concerned with forests and forestry in Eastern Canada.

The first day's events, under the auspices of the Canadian Forestry Association, included the annual business meeting on Wednesday morning

and the public session on Wednesday afternoon. In the absence of the President, Col. Dennis, and the Vice-President, Mr. J. S. Gillies, the chair was taken by Hon. Sydney Fisher. The Directors' report of the work during 1918, (reproduced elsewhere in this issue), was adopted. The election of officers, noted under another heading, gives the Association the valued guidance of Mr. J. S. Gillies, of Braeside, Ontario, in the office of President for 1919. Mr. Clyde Leavitt, who has not spared himself in the Association's interest, was elected Vice-President, and Mr. Percy B. Wilson of Sault Ste. Marie a new director.

The Directors recommended that the salary of the Secretary for 1919 should be \$3,300. This was carried.

### A Varied Programme.

The afternoon meeting, at which Hon. Mr. Fisher presided, commenced with an address by Major Barrington Moore, second in command of United States forestry operations in France. Major Moore's interesting paper is reproduced in the present issue of the Journal. Mr. F. J. Campbell, President of the Canadian Pulp and Paper Association, and Mr. W. Gerard Power, President of the Canadian Lumbermen's Asso-



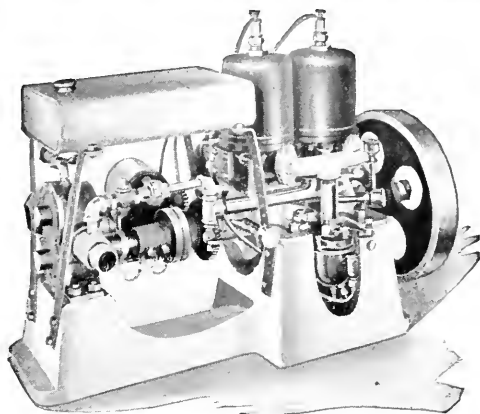

## FAIRBANKS-MORSE FIRE FIGHTING ENGINES

These compact powerful little pumping outfits have repeatedly substantiated our claims during the past year, all over Canada. They can be readily transported wherever man or pack horse can go. Governments and Private Owners of Forests everywhere, can materially reduce their fire losses by the use of these outfits.

Full information and prices on request.

### THE CANADIAN FAIRBANKS-MORSE CO.

LIMITED

MONTREAL - OTTAWA

ST. JOHN, QUEBEC, TORONTO, HAMILTON, WINDSOR,  
WINNIPEG, SASKATOON, CALGARY, VANCOUVER, VICTORIA.

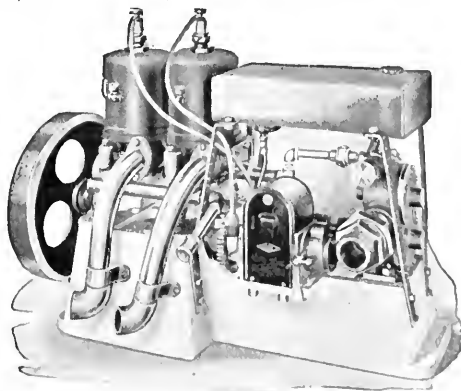

**CONFEDERATION LIFE  
ASSOCIATION**

**UNCONDITIONAL  
ACCUMULATION  
POLICIES**

Are liberal up-to-date contracts which guarantee to the insured every benefit consistent with safety.

**WRITE FOR PARTICULARS**

which will gladly be furnished by any representative of the company or the

**HEAD OFFICE,  
TORONTO**



**QUEEN'S  
UNIVERSITY**

**KINGSTON  
ONTARIO**

**ARTS MEDICINE  
EDUCATION  
APPLIED SCIENCE**

Mining, Chemical, Civil, Mechanical and Electrical Engineering.

**HOME STUDY**

Arts Course by correspondence. Degree with one year's attendance.

**SUMMER SCHOOL**

JULY AND AUGUST

**NAVIGATION SCHOOL**

DECEMBER TO APRIL

GEO. Y. CHOWN, *Registrar.*

**R. O. SWEEZEY**

(B.Sc., M.E.I.C.)

**WATER POWERS.    TIMBER LANDS.**

**FINANCING**

**164 St. James Street - MONTREAL.**

**UNIVERSITY OF  
NEW BRUNSWICK**

**FREDERICTON, N.B.**

**DEPARTMENT OF FORESTRY**

Established in 1908.

Best of facilities for definite instruction and supervision in Practical Forestry.

Surveying, cruising and construction work carried on in our own tract of 3600 acres, with Forestry Camp in the centre.

Competent men from the School at present in demand to take up Forest Survey work with the Provincial Crown Land Department.

For further information address:

**DEPARTMENT OF FORESTRY**

University Calendar furnished on application.

C. C. JONES, *Chancellor.*

**P. L. BUTTRICK**

CONSULTING FORESTER

**NEW HAVEN, CONN., U. S. A.**

P.O. BOX 607

**TIMBER ESTIMATES**

**UTILIZATION STUDIES**

**PLANTING PLANS**

**Landscape and General Forestry Work.**  
Eight years experience in practical forestry work of all sorts.

ciation, gave excellent addresses on the future of their respective industries in relation to the supply of forest materials. Mr. Campbell's paper is reproduced in these pages, in part, and Mr. Powers' address will be contained in the March issue. In the absence of Hon. W. R. Brown, his chief forester Mr. L. S. Linn read a paper on "Results of Clear Cutting and Selective Cutting."

#### The Quebec Forest Protective Association.

On Thursday morning the Quebec Forest Protective Association and the Woodlands Section opened their meeting under the chairmanship of Mr. Ellwood Wilson. Hon. Jules Allard, Minister of Lands and Forests of Quebec, addressed the meeting and was followed by Brig. Gen. J. B. White, D.S.O., in charge of Canadian Forestry Operations in France. Mr. J. M. Swaine, Entomologist, in charge of forest insect investigations, read an excellent paper on insect injuries to forests, emphasizing the importance of slash disposal if insect enemies were to be efficiently combatted. An address on slash disposal, prepared by Mr. Ellwood Wilson, was read by Mr. Clyde Leavitt, Chief Forester of the Commission of Conservation. Mr. T. W. Dwight, Assistant to the Director of Forestry, Ottawa, gave a resume of slash disposal operations conducted by the Dominion Forestry Branch in Saskatchewan. Dr. Lyman Fisk of

Life Extension Institute, New York, spoke on "Is Health Good Business?" The Forestry Journal will endeavor to give portions of these papers in future issues.

The afternoon was devoted to a very effective address on aerial photography by Lt. Lewis of the Royal Air Force, illustrated by excellent views taken over European and Canadian positions. Upon Mr. W. Gerard Power assuming the chair and inaugurating the session of the Woodlands Section of the Canadian Pulp and Paper Association, the report of the committee on "Improvements in Logging Operations" was brought in and after much discussion the meeting decided to refer back the report to the committee for further consideration. A report on hardwood utilization was read by Mr. Volkmar, Forester of the Riordon Pulp and Paper Company.

The Annual Meeting of the Canadian Society of Forest Engineers on Wednesday evening proved to be one of the most enjoyable and helpful gatherings of the society since its formation. The attendance was especially gratifying and from the reading of Dr. Howe's fine paper to the concluding ceremonies of the evening, the interest of those in attendance was remarkably keen. Mr. Ellwood Wilson presided. The Annual Meeting of the Quebec Forest Protective Association was held on Thursday evening.

#### TABLE OF CONTENTS.

|  |    |
|--|----|
| An Imperial Forest Policy. By Sir John Stirling Maxwell .....            | 56 |
| The State's Duty in Managing Forests. By Hon. E. A. Smith .....          | 66 |
| The Tree-Soldiers of France. By Major Barrington Moore .....             | 68 |
| World Demand Shortens Life of Our Forests. By F. J. Campbell .....       | 79 |
| The Making of a Spruce Tree. By Dr. C. D. Howe .....                     | 59 |
| Australia Steals a March on Canada. By H. R. MacMillan .....             | 51 |
| The Miracle of Gascony's Pine. By Brig.-General J. B. White, D.S.O. .... | 61 |
| The Day After Tomorrow. By Robson Black .....                            | 74 |
| A Year of Propaganda .....   | 82 |
| The Meeting at Montreal .....  | 90 |

## Index to Chief Articles in Canadian Forestry Journal, 1918.

|   | Month.    | Page.   |
|---|-----------|---------|
| <b>AEROPLANES</b>   |           |         |
| Guarding Forests by Aeroplanes. K. E. Kennedy.....  | February  | 1521    |
| The Race for Aeroplane Spruce.....  | September | 1865    |
| The Aeroplane in British Columbia Forests.....  | December  | 1957    |
| Building a Canadian Aeroplane.....  | December  | 1960    |
| <b>BRITISH FORESTRY</b>   |           |         |
| Britain's Penalty for Neglected Forests. Sir John Maxwell....                                   | March     | 1600    |
| Britain Turns to Canada's Forests.....  | May       | 1696    |
| Britain's Need—Canada's Opportunity. J. R. Dickson.....   | November  | 1908    |
| The Prop of Our Empire.....   | November  | 1936    |
| <b>CANADIAN FOREST CONDITIONS</b>   |           |         |
| Forest Resources of McKenzie Basin. H. J. Bury.....   | January   | 1481    |
| Forests of Canada in Peace and War. Robson Black.....   | March     | 1574    |
| Seignory of Lotbiniere. L. Garneau.....   | April     | 1621    |
| Facing the Truth of Forest Exhaustion.....  | May       | 1677    |
| Menace to Our White Pine. J. H. Faull.....  | May       | 1685    |
| Bringing Back the White Pine Forests. R. H. Campbell.....                                       | July      | 1765    |
| Why Forest Reserves are Created. H. C. Wallin.....  | July      | 1780    |
| Canada's Pulp Wood Resources.....   | July      | 1785    |
| Nova Scotia's Stake in Forestry.....  | August    | 1817    |
| High Mortality of Balsam Fir. Dr. Howe.....   | November  | 1929    |
| The Case for Nova Scotia's Forests. R. Black.....   | November  | 1940    |
| New Brunswick to the Fore! And Why? G. H. Prince.....   | December  | 1982    |
| <b>ENTOMOLOGY</b>   |           |         |
| Control of Foliage Eating Insects Under Forest Conditions.<br>J. D. Tothill.....                | May       | 1673    |
| A New Forest Insect Enemy of White Birch. J. M. Swaine.....                                     | November  | 1928    |
| <b>FOREST METHODS</b>   |           |         |
| Second Crop of Pulp Wood. H. C. Belyea.....   | August    | 1836    |
| The Forester's Place in Planning and Operating Wood-using<br>Industries. W. F. V. Atkinson..... | March     | 1595    |
| Practical Application of Scientific Forestry. R. O. Swezey....                                  | April     | 1638    |
| Firmer Handling of New Brunswick Forests.....   | November  | 1934    |
| New Ways in the Woods. Ellwood Wilson.....  | May       | 1688    |
| <b>FIRE PROTECTION</b>  |           |         |
| Fire Fighting on the St. Maurice.....   | April     | 1645    |
| Fire Fighter's Profession. E. T. Allen.....   | May       | 1683    |
| Minnesota Fires.....  | November  | 1911-12 |
| Forest Protection in British Columbia. Clyde Leavitt.....                                       | November  | 1918    |
| <b>MISCELLANEOUS</b>  |           |         |
| Logging by Elephants in Burma.....  | April     | 1630    |
| Farming Muck Lands.....   | May       | 1671    |
| Forestry and the War. Dr. Fernow.....   | May       | 1691    |
| Finland's Public-Owned Forests. S. T. Dana.....   | June      | 1727    |
| Riddance of Patronage: A Great Gain.....  | July      | 1773    |
| Forest Legislation in Canada, 1917-18.....  | July      | 1791    |
| Grow Trees for Aeroplane Building.....  | August    | 1813    |
| Scientific Investigation Holds the Key to Canada's Future.....                                  | August    | 1821    |
| Great Timber Wealth of South America.....   | August    | 1833    |
| New Use of Birch for Paper Making.....  | November  | 1922    |
| New Birth of Forestry. Dr. Roth.....  | November  | 1924    |
| Do Forests Increase Rainfall. Dr. Fernow.....   | December  | 1965    |
| Research Studies.....   | December  | 1968    |
| <b>RAILWAY FIRE PROTECTION</b>  |           |         |
| Status of Railway Fire Protection in Canada. Clyde Leavitt....                                  | June      | 1731    |
| <b>TREE PLANTING</b>  |           |         |
| Choosing Trees for Ornamental Planting. O. Bedard.....  | March     | 1591    |
| Growing a New Forest Family at St. Jovite.....  | September | 1860    |
| Planting the Home Grounds.....  | September | 1863    |
| Women a Success in Planting Work. Prof. Gordon.....   | December  | 1961    |
| <b>WOOD FUEL</b>  |           |         |
| Wood Fuel to Relieve Coal Shortage. Clyde Leavitt.....  | January   | 1473    |
| How Uncle Sam Attacks the Wood Fuel Problem. A. F. Hawes....                                    | February  | 1525    |
| Fuel Value of Wood. W. B. Campbell.....   | April     | 1632    |
| Management of Woodlots. G. C. Piché.....  | June      | 1738    |
| A Small Town in the Wood Business.....  | September | 1867    |

IF YOU WANT A CHEW  
THAT WILL JUST SUIT

YOU ASK FOR

**STAG**

**CHEWING TOBACCO**

RICH AND SATISFYING.

IT IS ALSO KNOWN TO BE  
"EVER-LASTING-LY GOOD"



SCHOOL OF FORESTRY

APR 4 1919

UNIVERSITY OF TORONTO

# Canadian Forestry Journal

March 1919

SIWASH ROCK, BRITISH COLUMBIA



## THE ROAD TO YESTERDAY

is blocked with the rubble of Good Intentions. The Road to Tomorrow is wide, wide open. Before traffic conditions change for the worse, will you pay a real compliment to a son, brother, cousin, neighbor, or foe by telling the Forestry Association, 206 Booth Building, Ottawa, to send him twelve issues of the Illustrated Journal. Pin a dollar to your letter. We'll acquaint the new subscriber with your thoughtfulness.

Most men who like a tree like the Forestry Journal.





# Canadian Forestry Journal

VOL. XIV.

OTTAWA, CANADA, MARCH, 1919

No. 3

## JACK MINER AND HIS WILD FOWL



### The Story of a Remarkable Experiment in Attracting the Birds of the Air.

(From Mr. Miner's Address given at the Annual Meeting of the Commission of Conservation)



I assure you it is a privilege for me to meet with so many bird lovers. We love out-of-door creatures, or we would not be here this morning.

Now, you will have to pardon my lack of education. I am one of those men who are born bare-footed and educated out-of-doors. However, I was my father's favorite. Perhaps it is not just the proper thing for fathers to show partiality, but mine did. He always called me in the morning to build the fires; possibly in that way I got out a little earlier than the rest to hear the birds singing.

Outside of unavoidable sadness, my life has been one continuous round of enjoyment; the failures and disappointments and the dark storm clouds have been wiped out of existence by success, by out-of-door life—a light which has brightened my path right up to the present and given me a faint glimpse of the beyond. I have heard people say that they have read that there was never a tribe of heathen discovered on earth who did not worship some kind of god. No intelligent man can live out-of-doors without being compelled to believe that there is an overruling power.

#### The Domain of Man.

God created the fowls of the air, and so on, before He created man, according to Genesis 1st chapter and 21st verse. Then in the 26th verse we find these words: "And God said, 'Let us make man in our image, and after our likeness, and let them have dominion over the fish of the sea, and over the fowl of the air, and over the cattle, and over the earth, and over every creeping thing that creepeth upon the earth.'" Does that mean that we are to have dominion over these big flocks of wild geese, so far away that you have to look twice to see them? You know how high they sometimes are; you can

hear them. That is what it says, gentlemen. Then we read further in Deuteronomy chapter 22, 6th and 7th verses: "If a bird's nest chance to be before thee in the way in any tree, or on the ground, whether they be young ones or eggs, and the dam sitting upon the young, or upon the eggs, thou shalt not take the dam with the young; but thou shalt in any wise let the dam go, and take the young to thee; that it may be well with thee, and that thou mayest prolong thy days". But, if a duck lit in one of the rivers here, all of us educated people would rush down—there would be ten guns out there to shoot it. Reading in the book of Job, we find these words:

"No doubt but ye are the people, and wisdom shall die with you. But I have understanding as well as you: I am not inferior to you: Yea, who knoweth not such things as these?"

"But ask now the beasts, and they shall teach thee; and the fowls of the air, and they shall teach thee."

#### His First Experiment.

When the first barn swallows came to our tile shed, on our little farm at Kingsville, Ont., they nested 300 feet away—as far away as they could get from where we were working. We protected the swallows from their deadly enemy, the sparrow that man brought to Canada—the English Sparrow; not the one that God put here, don't forget that. They destroyed the first brood, but we protected the swallows, and consequently the sparrows didn't destroy any more. Remember, the shed had stood there for ten years, equally as inviting. The second year there were two nests; the fifth year there are twenty nests in the tile shed, and, instead of being as far from us as they can get, fifteen out

of the twenty nests are within twenty feet of where we are working. They have come to us for protection, you have to believe that. They destroy large numbers of house flies. The ladies say—of course, the ladies never tell what is not true—that there is not more than one house fly now where there were five previous to the coming of these barn swallows, purple martins, and so on. Scientists tell us that the typhoid fly will carry that deathly disease, and if we preserve the swallow which destroys these flies, surely it will be well with us and we will prolong our days. We protected one nest; now one hundred swallows are raised in that shed every year.

### Rescuing a Robin.

Now, what good is the robin? Everybody knows the robin. A boy came along the road with a .22 rifle, saw a robin sitting on the fence, and killed it. I went over and picked the robin up. Two cutworms were squirming on the ground; the robin had had them in his beak. I held the bird up, and two more fell out of his mouth. Remember, one cutworm will cut down five tomato plants in a night. This fellow does his work and then hides under the soil; Mr. Robin comes hopping along, picks in there and pulls him out—and turns him into a robin. If anyone tells you that a robin will destroy one hundred cutworms in a day, take it from me that it is true. The morning after this boy promised me that he wouldn't shoot another robin, at the fir-tree by our house were two little robins dead under the nest and two in the nest just alive. We took them into the house—it is wonderful what an effect a little bird can have on our family. One bird will stop a whole plantation; I have known a wild duck to stop the whole brickyard. However, we took these two robins in, warmed them up, and made some custard for them—one egg, half a cup of milk, no sugar. They couldn't open their mouths, they were so nearly gone. We took one of them, pried its beak open and dropped in some custard, and the first thing we knew he came to, and in a minute or so began to squeak for more custard. The other little fellow was supposed to be dead, but he, too, soon began to look around, and these two robins became the sweetest birds we ever had on the premises.

You know how a door will slam once in a while in the house. Well, there was a good slam one morning, when someone had left the screen door open and Jasper's pet robin—Jasper is our son—had come in and was resting in what we call the cold storage—a room in the

front of the house which is sometimes called the parlor. Here he was on his mother's picture, and the broom was going smartly after him. Jasper came with a tin, the robin flew into the tin, and the boy carried friend robin out to safety. That is how we get enjoyment out of these things.

### Do Birds Come Back?

Do birds come back to their homes? How many times I have been asked that question. Oh, yes, they do come back. "Well, how do you know, Jack?" Then you would have to talk about the weather—switch the subject. But I will tell you the rest of the story.

I hatched four wild young mallards—well, I didn't hatch them; I stole the eggs. A domestic fowl eventually hatched out four little wild ducks, and there they were, under the old hen, wilder than park horses. However, the old hen's voice soon brought them out, and several little girls began to come out from under their step-mother and look around, and eventually they would take some of the custard right in my presence. These ducks soon were so tame that the tap of a tin would bring them to you. They got to be quite a size, and we named them, respectively, Polly, Delilah, Susan and Helen, and presented each one with an aluminum tag, on which was printed the words, "Box 48, Kingsville, Ont." When autumn came the four ducks migrated—that is, on or about Dec. 10th, 1912. Dr. Rutherford, of Chatham, shot one, Helen, at Mitchell's Bay, Lake St. Clair. How they got to the east of us I don't know, for they started south. I guess they had taken such a liking for me, that they started for Ohio, where I was born. On March 14, 1913, Polly came home. On March 18, Delilah came home, and on March 30, Susan, although wounded in the wing and foot, returned home. Is that not an answer to the question, do birds return to the place from whence they migrated? Well, I wanted to go down, hitch up the self-starter, and go to town, so that someone would ask me, "Do birds return home"?

### Delilah and Polly.

They migrated that autumn, and on March 14, 1914, Polly came home. On March 21 Delilah came home for the second time. The two girls raised families the next year—and, by the way, they brought a Yankee sweetheart with them; and it is interesting, when they are arriving, to see the ducks come down and try to coax their new mates down too.

Well, they migrated again for the third time. In the spring of 1915 Delilah got home first; she



So far on the Mr. Milne's enterprise become that as many as 1,000 people visit the bird sanctuary in one day

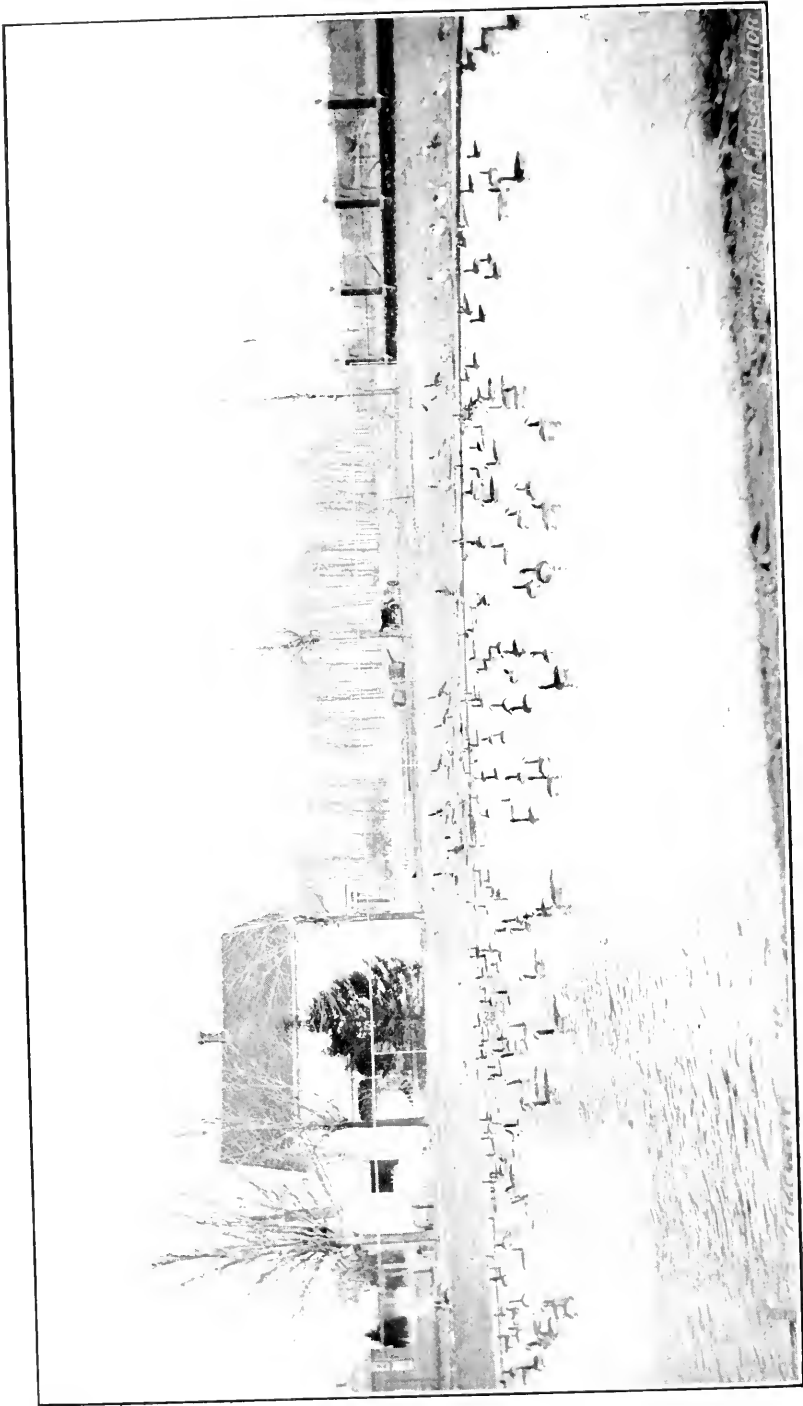

Wild Geese quite contented to accept human hospitality. Photograph taken at Jack Miner's home, Essex County, Ontario.

Wild Geese quite contented to accept human hospitality.

arrived on March 13, and Polly came home on March 16. Polly had got her beak a little too far ahead and a shot had grazed right across it and cut the side off, leaving it hanging. She would just stand around with her mouth open. I got some porridge and mixed custard with it and the second day I had Polly in my right hand. In a week or so I took these ducks to a photographer, stood them on the table, brushed them down and talked to them quietly and got a photo of them.

#### Back the Fifth Time.

We often make remarks about silly old geese and silly old ducks; sometimes I wonder what the ducks and geese are saying about us. These ducks have shied around to keep clear of people hiding in ambush for them; then they come home and in a few days are eating out of our hands. Isn't it worth thinking about? Talk about loving these birds; you simply can't help it, if you are human. Polly said: "I am going to stay with you, Jack, from now on", and she stayed in the hen house with my birds in the winters of 1915 and 1916. However, in the spring of 1916 she got shot, but Delilah migrated and got back March 5, for the fifth time; migrated again, and got back in 1917 on March 25, and last spring she came back for the sixth time on March 19. Do birds return to their homes? I know that it was the same tag she had on, because my wife and I took it off her leg after it had been on five years, and we presented her with a new tag. I am now making my tag system a little more interesting, by putting on the blank side a verse of Scripture. Everybody who brings down a goose with my tag on it gets a verse of Scripture, whether he needs it or not. Mack Stewart, of Tennessee, writes: "Send me the history of this bird or any other Canadian bird". Corporal John R. Smith writes: "White, age 23, still unclaimed, can you help me out"? So I took the two letters and handed them over to the ladies in our Sunday school, and the same day one of them came back. There are ten of us in one class, and we went and stamped this on our tag: "Let us consider one another"—Hebrews 10: 24.

Now, where do these ducks go?

"Ask now the beasts, and they shall teach thee; and the fowls of the air and they shall tell thee".

#### Tagging the Ducks.

I have caught and tagged 287 wild ducks. My home is on the north shore of Lake Erie, due north of Pelee Island, twenty-six miles south-east of Detroit, at Kingsville, Ontario—

well, I am a little way out of the town. Kingsville is the place where more fowls go than anywhere else in North America, I believe: the fowls of the air, it is their choice. I have twelve tags from Ohio, due south of me; nine from Kentucky, nine from Tennessee, leading right on to the Gulf of Mexico, and seven from Alabama. I have one from Saskatchewan, one from Alberta and several from Manitoba. I have only four or five tags from west of the Mississippi. I have them as far east as Long Island, New York, as far west as Alberta, as far south as Louisiana, and as far north as Sault Ste. Marie. I haven't a tag for a wild duck north of Sault Ste. Marie, although I know that they go further up there.

I have nine tags off the wild geese from Chesapeake Bay, seven from North Carolina, one from Maryland and one from New Jersey, but none between my home and that southeast coast of Chesapeake Bay. Do these wild geese come clear over to that Kingsville pond without a stop?

#### Returns From Hudson's Bay.

Now, they stay with me about two months. They come about the first of March—in fact, the earliest we have had them is Feb. 20, and the latest, March 16—and stay until the last week in April or the first of May. We have 25 tags returned from James Bay and Hudson Bay, and only one from the west side of James Bay, which is Albany, and 24 have come right along the east coast. Those 25 tags, ladies and gentlemen, are in my possession and I am sorry that I didn't bring them along. The Indians shoot them and take the tags to the Hudson's Bay Company agent, I suppose through curiosity, mostly, and the agents eventually return the tags. I have 25 out of the 102 that I put on; 25 have been returned from there and only nine from the south.

How did we find out about these wild geese? I have gone five miles from home before the stars closed their eyes in the morning. Wild geese are quite scarce; I went four mornings in succession and never saw one. There I lay under a blanket, just as the stars were closing their eyes, with three or four wild goose decoys out. Suddenly, at daylight, I see friend wild goose coming, bringing his family with him. I can just see the tip of the wings begin to move—a faint hum, coming closer. Everything is pretty quiet—but my heart sinks; here are two men coming out there in the next field. It's all off; those fellows will secure the geese. But, no;

(Continued on page 138)



Planting forest trees by private initiative in Simcoe County, Ontario. Photo taken on the day of planting, five years ago. See top of page 106.



After the ground had been worked the first time to kill the weeds.



The plantations at the end of one year. Snow covers most of the trees.



There are over 2,500 Scotch pine in this block, averaging over 11 feet high, grown from sets six inches high, in about 5 years. Many of the trees are 15 feet high.  
Plantation of Reeve Holden, of Collingwood.

## MAKING THE EARTH TO BRING FORTH FRUITS

Reeve William J. Holden, of Collingwood, Ontario, is one of hundreds of Canadians who puts his forestry gospel into practice. Mr. Holden was asked by the Ontario Minister of Agriculture over five years ago to make a trial of reforestation in Nottawasaga. The ground was prepared and in the following spring with the aid of students from the Agricultural College, 16,000 seedlings were planted. An exceptional drought the next year reduced the plants to 12,000. There are about 8,000 pines, the remainder being walnuts, chestnuts, locusts and cedars.

Mr. Holden has been doing valuable missionary work in Simcoe County, Ontario. Under his inspiration the County Council appointed a Committee which recently advised the purchase of four plots of 50 acres each for purposes of tree planting. As with Simcoe County, so with every other county in Eastern Ontario: at least 25 per cent should have been "cultivated" for tree crops. The farmer's woodlot, however, has been the poor relation of the agricultural family. Soils have not been properly classified, with the result that millions of acres have been mistakenly deprived of their natural forest cover with no chance whatever of raising any crop other than timber. The vast areas of drifting sand dunes in Ontario and Quebec are just two of the logical consequences.

## A CIVIC PLAN FOR STREET TREES

By *B. R. Morton, B.Sc.F., Dominion Forestry Branch;*  
*Author of "Native Trees of Canada".*



Every-Man-for-Himself Means a Hodge-Podge  
of Tree Planting.—Expert Oversight  
Essential.



It is unfortunate that in so many of our Canadian towns and cities the work of caring for and planting of street trees is not systematically carried out. Instead of having a properly organized municipal shade tree department the work is too often left to the individual property owner with results which are far from satisfactory. The individual is perhaps not to blame for the results. He is spending time and money from which the public as a whole will benefit, but he is working without instructions.

### A Treeless Town!

The value of shade trees to a town or city is inestimable. Well cared-for trees in the street and parks contribute immensely to civic pride and patriotism. They are one of the greatest aids to the attractiveness of a community. A treeless town cannot be beautiful although it

possess many fine buildings. A street of plain tenement houses can be made attractive by the uniform planting of trees to break the harshness of the bare rows. Visitors to a city are impressed as much by the city's trees as by its buildings, and are influenced by them in deciding if the city is a desirable one in which to live. Trees are an asset, adding value to property. From the standpoint of health and comfort well shaded streets are desirable, for they modify the temperature on the hottest days by cutting off the direct rays of the sun.

### A Street Tree Department.

To obtain the best results the work of planting and caring for the trees should be entrusted to a special department. This department should be responsible for the selection of suitable species and proper spacing as well as the protection and



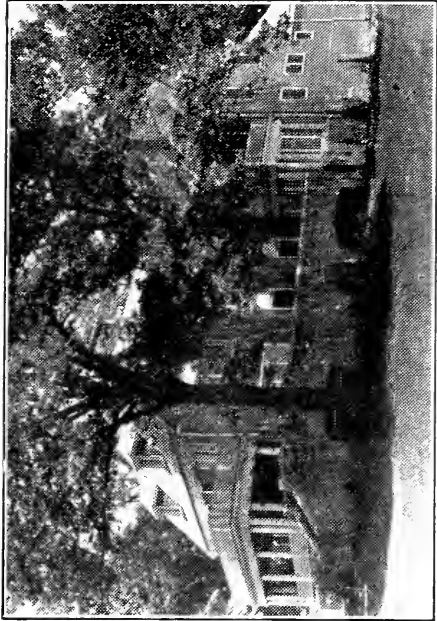

This home owner built part of his house round a tree rather than destroy it.



Instead of slaughtering these trees to convenience a stone wall, archways were constructed over the roots and the trees thereby carefully preserved.



A public highway in which the natural features have been carefully preserved.



any necessary trimming and repairing that may be required. It is only where a street tree department exists and has control of all tree work along the public highway that stately, impressive, uniform results can be expected.

Where street planting is to be done the appearance of the street as a whole should be taken into consideration. This is not done when the work is left to the individual citizens. The average owner consults only his own taste in regard to species and spacing and concerns himself only with the section immediately in front of his property without regard to his neighbor's plans. An error that many owners fall into is the planting of too many trees on their frontage. They overlook the fact that trees which appear widely enough spaced when young may be much too crowded when grown to full size. Frequently property owners will space their trees closely when planting, with the intention of removing certain ones before they begin to crowd. When the time comes for cutting, however, the ownership of the property may have changed and the new owner either

lacks courage to do any cutting or does not feel himself under any obligation to do so. As a result, the trees grow up much too crowded and spoil the appearance of the street.

#### Helter-Skelter Planting.

Looking along a street on which the planting and care of its trees has been left to the individual property owner one finds within the distance of a few blocks a dozen or more species, all sizes and shapes. Desirable species are mixed with undesirable, some sections planted too close and others too far apart. Long stretches will not be planted at all. Many trees will be thinned too high and others branching so low that they interfere with pedestrians and vehicles passing beneath. Flourishing trees will be found intermingling with those in need of repair and rapidly dying for lack of attention. The whole street has an untidy appearance and lacks the impressive beauty produced only by well-cared for trees, well selected and planted.

Look along some of your own streets and decide whether the attractiveness of your town cannot be improved.

## SOME FACTS ON THE WHITE PINE MENACE

By *W. A. McCubbin.*

A survey of pine infection (Blister Rust) areas was made in order to obtain evidence as to the actual damage which has been brought about by the disease. This survey covered 35 plantations in three districts, and involved the examination of 14,428 young pine trees, 10 feet in height and under. In the Niagara district the disease was most prevalent. In the 22 woodlots examined here the disease was found in 19. Out of the 11,579 pines examined 270 were found to be diseased. This gives an average of 2.3 per cent infected trees, and is apparently very small. It is to be noted, however, that the highest record percentage of infection was 33.54 and in at least two other cases where the percentage is 20 or under, the estimate was made in woodlots from which a very large number of young trees had been removed.

From our knowledge of the disease here in past years which gives a fair idea of the time the disease has been present in each locality it would seem that under average conditions the disease attacks about 1 per cent of pines

per year. This is extremely low when one considers the Ribes situation in the Niagara Peninsula, and from it one may obtain cheering prospects for future control measures. In the 10 plantations examined at Oakville, where the disease has been present since 1915 at least, only one diseased pine was found out of 2,249 examined, and in Simcoe County where a centre of infection had existed since 1912 at least, no diseased pines could be found in the three plantations examined, covering 600 pines.

It is apparent from the results of this survey that three factors are concerned in infection of pines:

- (a) The nearness of cultivated Ribes, particularly black currants.
- (b) The number of wild Ribes present.
- (c) The moistness of the situation.

It has been found that on swampy land wild Ribes are plentiful, luxuriant and become infected very completely, while on higher and drier situations, they are less plentiful and the infection is often negligible.



## "Trees"

By Harold Munro.

They follow us and haunt us. We must  
build  
Houses of wood. Our evening rooms are  
filled  
With fragments of the forest: . . . .

We sit, move, sleep among the limbs of  
trees,

Rejoicing to be near them. How men saw,  
Chisel and hammer, carve and tease  
All timber to their purpose, modelling  
The forest in their chambers! And the raw,  
Wild stuff . . . .

Will crack and shiver in the night, and  
sing

Reminding everybody of itself;  
Out of decayed old centuries will bring  
A sudden memory of growing tree.

So they are felled. The hatchet swings:  
They pass their way. . . . Some learn  
to sail

Seaward on white enormous wings,  
Scattering blossom along their trail;

And some, some trees, before they die,  
Carved and moulded small,  
Suddenly begin,—  
Oh, what a wild and windy woodland call  
Out of the lips of the violin!

So trees are felled. . . . But tree  
Lingers immovable where it has stood,  
Living its tranquil immortality  
Impassive to the death of wood.  
And you—be certain that you keep  
Some memory of trees for sleep.

### B. C.'S FIRST AIR PATROL.

The first aerial forest patrol in British Columbia will probably have to do with a tract of valuable timber, situated south of Victoria, and running for 125 miles along the coast.

### ALBERTA HAS FIRST HONORS.

One experiment in aeroplane work, and only one, has been authorized thus far by the Dominion Government. Some time during the summer the Dominion Forestry Branch will test a machine in Alberta. It is understood that the ordinary military plane as it stands is regarded as unsatisfactory for forest guarding, and that a stock machine of slow speed will be considerably altered under the direction of Canadian aviators who understand fire protection work. This is an interesting and commendable move on the part of the Dominion Forestry Branch and will be eagerly watched.

### FIVE MILLION SEEDLINGS A YEAR.

The Provincial Forester of Quebec, Mr. G. C. Piche, announces that the capacity of the tree nursery at Berthierville, is to be increased to an annual production of 5,000,000 young trees, partly in contemplation of the Provincial Government adopting a programme of forest planting on denuded Crown timber lands.

If it pays the big pulp and paper companies to reforest their waste lands, planting three-year-old seedlings at a cost of from \$9 to \$10 an acre, why should it not pay the provinces which have large areas of waste land to pursue the same policy? asks the St. John, N.B., Telegraph.

### OIL FROM BEECH NUTS.

The nut of the beech tree yields a valuable oil, used in soap-making, and as an illuminant. At the present time, when the scarcity of oil is a serious matter, these nuts become still more valuable. In the Danish forest the work of clearing the ground of withered leaves, under and around the beeches, has now been started, in order that the work of gathering the nuts, in the autumn may be more easy, and the result more satisfactory. The nuts will be collected (in Denmark) in October and November, and transported to the oil mills.

### IN SOUTH AFRICA.

South Africa has spent some 2,500,000 pounds sterling on organizing the wild forest, and the work is only about half done. It is now spending about one-seventh of a million pounds yearly.



An indication of what the aeroplane camera might do in mapping the forests of Canada. There is a lamentable lack of forest maps in the Dominion. Some aviators claim they can distinguish tree species by examining stereoscopic photographs and by other methods. This, of course, would be only of general value and the ground cruise would always be necessary. Note the remarkable boldness of outline at 15,000 feet. (A photograph taken on the French front.)

## PHOTOGRAPHING FORESTS FROM THE AIR

By *Lieut. Lewis, R. A. F.*



Use of Stereoscope in Reading Results—Dis-  
covering Burned-Over Areas.—Can  
Species be Identified?



So far as I know, air photographs have not been used up to the present, for other than war work, and my experience with them has been entirely in that sphere. Such marvellous results were obtained from them during the course of the war, particularly during the latter part, when planes, cameras and operators were more efficient and ground interpreters became more familiar with their work, that I think it is the duty of those of us, who became experienced in

their use, to pass that experience on to those in commercial life, who are most likely to find it of value. The timber industry seems to me to be one in which their use has great possibilities.

### Interpreting Photographs.

For about a year of my stay in France, I was employed in the Intelligence Department, and among my duties was the interpretation of aerial photographs and the transferring of information thus gained, to our maps. Of course we already



How wooded areas are defined by camera from 15,000 feet in the air. The strips of white and grey in blocks represent cultivated land, the difference in shading being accounted for by various crops, hay, grain, stooked and uncut fields, meadow, etc.

Photos by kindness of Major MacLaurin, R.N.A.S.

had maps on the country as it was before the war, but the defensive works constructed on both sides would have necessitated elaborate surveys which, of course, it would have been rather dangerous to attempt in the vicinity of the front line trenches. By experience we learned to know the appearance on a photograph of the numerous defensive works in the enemy lines, trench systems, machine gun emplacements, trench mortar emplacements, gun pits, dug outs, wire entanglements, telephone lines, buried cable lines, and many other constructions became known to us, and the result was that our artillery could deal with these things, and the Canadian artillery have a decidedly efficient way of dealing with things that are bothering their brothers-in-arms, the infantry.

The average height from which these photos were taken was from 6,000 to 8,000 feet. Now, if such accurate results could be obtained at these heights how much more could be done with photographs taken, say from 1,500 feet, with nothing to ruffle the nerves of the operators?

I understand that the Government may establish an aeroplane or hydroplane forest patrol for fire ranging purposes. Why not have these planes fitted with photographic outfits for the purpose of mapping that part of the country of which so little is known, the importance of it to the lumber industry seems to me, although not a lumberman, to be too great to be overlooked. I have found an idea of how this work might be done for the lumber companies.

#### How to "Snap" Forests.

They might make arrangements with the Government to have their own limits photographed, merely paying rent for the machine while on their work, and the cost of the photographs, approximately \$4.00 per dozen. This would cut out the necessity for having machines, operators, and cameras of their own.

First of all, take the timbered area which carries a variety of trees, it need only be a small area. Have it accurately cruised, or better still, have a survey made of this one small area and have species of trees given and also condition of ground as to rock, outcropping, etc.

Then have this area photographed at two seasons of the year, preferably in the spring before the leaves come out on the deciduous trees, and then again when they are in full leaf. These photographs will be taken from a known altitude in order to arrive at a scale. Have them carefully analysed in every detail and records made. They could then be used as standards in analysing photographs of any tract of timber land, and I am quite sure that an accurate estimate could be made of standing timber, burnt over areas, areas fit for forestation and reforestation and also the water in the vicinity. If photographs were taken with a stereoscopic camera they could be viewed through a stereoscope and undulations of the ground which would tell the direction of the flow of streams observed. I should imagine, however, that the map would be sufficient to show this.

If a stated altitude is maintained in taking all the photographs they will naturally be of the same scale and a continuous photographic map of any area can be obtained. Each company could have a natural photograph of its own limits hanging on the wall, could see exactly where logging is going on, and if they wish to do so, could keep track of the progress of the work.

I do not for a moment suggest that photography would be a means of dispensing with cruising in the woods, but I think that it would be of great assistance to cruisers and eventually they will all want to become enthusiastic interpreters of air photos.

### AIR PATROL IN QUEBEC.

The Province of Quebec does not intend to have airplanes of their own to patrol its vast forest area, but this session the St. Maurice Forest Protective Association will be given a subsidy to aid in its task of guarding the forests on the St. Maurice with airplanes. The association which comprises big companies with timber concessions is now in communication with the Hon. C. C. Ballantyne, Minister of Marine and Fisheries, with a view to securing some aeroplanes, and the work of patrolling by this method will commence next summer, according to reports to Hon. Jules Allard, Minister of Lands and Forests. Hon. Mr. Allard's bill respecting the protection of forests against fire was introduced in the Legislative Assembly by Hon. L. A. Taschereau.



Photo by E. R. Morton  
BORROWED FROM CHILE.

One of the oddest trees found in Canada: The Auracarian Pine, or "Monkey Puzzle" (so called because of the saw-edge formation of needles and the difficulty of climbing through them). This tree grows in Stanley Park, Vancouver. Its native habitat is Chile where it ranks as one of the great timber producers.

### Two Minutes to Spare.

So interested were twenty-seven of our members in the January and February issues of the Forestry Journal that they sent in letters to this effect:

"I want my friend — to read the Forestry Journal every month. I am enclosing one dollar to cover his fee. Kindly notify him."

Have you a friend in the same situation?

Why not bring a neighbor or two into line with the forest conservation movement in Canada? Membership is the Open Door.

Address, Canadian Forestry Association,  
206 Booth Building, Ottawa.

### WORLD'S FOREST SUPPLY.

With the exception of the United Kingdom, Algeria, and Cape Colony, Australia has less forest area, in proportion to total area, than any other settled country. It is but 5.35 per cent, compared with European Russia 43.04 per cent, New Zealand 25.65 per cent, Canada 22.33 per cent, Norway 21.50 per cent, Sweden 52.20 per cent, and the United States 24.08 per cent.

## CANADA LAGS IN TRIAL OF AIR PATROLS



---

 Generous Offer of Quebec Government to  
Employ Idle Machines This Summer  
Gets No Encouragement.
 

---



Why should Canada wait any longer to test the efficiency of the aeroplane in forest fire protection? The question has been threshed out for nearly three years, and while responsibility for the initial experiments has been passed along from one authority to another, the opinion of most of those who have made a close study of the subject is that the Dominion Government, with a ready supply of idle machines, and willing pilots, ought to take the first steps to secure reliable data in this most important enterprise.

According to The Forestry Journal's information, the Minister of Lands and Forests of Quebec recently proposed to the Dominion Minister of Marine and Fisheries that two of the idle hydro-aeroplanes now at Halifax or other Atlantic ports should be loaned to the Quebec Government for the summer season of 1919, the provincial authorities to foot the bill for upkeep of machines and pay of pilots. Hon. Mr. Allard, on behalf of the Quebec Government, intended to establish an experimental patrol over the St. Maurice Valley. It would appear that his co-operative offer was of a most generous and progressive character. It has not been favorably received by the Acting Minister of Marine and Fisheries, nor does there seem any prospect of having a start made in aerial forest patrol in Quebec even though public-owned hydro-aeroplanes are lying useless in their hangars in Nova Scotia and skilled pilots are kicking their heels and aching for some form of active service. The Canadian Forestry Association has addressed the Acting Minister of Marine and Fisheries on this subject and a deputation from the Association and allied bodies will bring the matter to the Government's attention during the present month.

If Canada is content to wait several years until the trail is cut by other more aggressive nations it will offer a poor comment on the ability of Canadians to initiate new lines of effort. The Forestry Journal is in receipt of communications from many senior aviators who look upon an aerial forest patrol as a simple, ef-

fective and inexpensive proceeding. Apparently, however, the idle machines and aviators at the disposal of the Dominion Government are to be denied an opportunity for splendid public service.

Not only is action called for by the imperative need of timber conservation, but other fields in which the Government is directly interested demand a bolder policy. It is understood that the Topographical Survey, the Geodetic Survey, Royal North West Mounted Police, and the Post Office Department are thoroughly convinced of the advantage of aeroplane service in increasing their efficiency and in certain instances reducing their cost of operation. These departments, however, are directly controlled by the Dominion Government and no matter how deeply convinced the executive officers may feel on the urgency of aerial experimentation, a refusal on the part of a Cabinet Minister to take action gives an instant quietus to the departmental agitation.

Those bodies, however, which have taken a constructive interest in Canadian forest policy are not as sensitive to this official denial and may be depended upon to intensify their request until proper consideration is given.

---

 THE ASPEN POPLAR.
 

---

The Aspen is one of these fore-runners, which, thanks to its prolific production of light, feathery seed, readily wafted by the winds over hundreds of miles, readily germinating and rapidly growing under exposure to full sunlight, even now everywhere quickly takes possession of the areas on which man has ruthlessly destroyed all vegetation by fire. This humble and ubiquitous tree is nature's restorative, covering the sores and scalds of the burnt mountain-side. Though short-lived, with its light summer foliage turning into brilliant golden autumn hues, it gives grateful shade and preserves from the thirsty sun and wind some moisture for the better kinds, which creep in and take its place, when it has fulfilled its mission. Dr. B. E. Fernow, Toronto.

# THE MAKING OF A SPRUCE TREE

By *Dr. C. D. Howe, Faculty of Forestry, University of Toronto.*

ARTICLE No. 2.

From the time the yellow powder described in the former article dusts the female flower to the actual beginning of the new tree a month or more may elapse and after that it is at least another month before the growing substance actually resembles a tree in form. At this time very tiny leaves appear and there are structures that later develop into stem and root. The little tree is completely enclosed in a very delicate membrane on the outside of which accumulates a white pulpy mass of food material for the young plant to live upon, during the germination period, until it can establish itself in the soil. The moist food substance is in its turn entirely surrounded by a heavy thick membrane impregnated with oily or waxy waterproof material, so that neither the stored food or the little treelet is in danger of drying out.

The structure we have been describing may now be called a seed. It consists of three principal parts: (1) an outside protective coat, varying from light brown to nearly black in color according to the kind of spruce tree; (2) stored food material occupying most of the space, and (3) embedded in the middle of the latter a miniature tree which has already developed root, stem and leaves, although it is not much more than one-sixteenth of an inch long.

## **Cone Development.**

In the meantime the structures on which the seeds are borne have undergone growth changes: the scales have enlarged and become woody. In August the cones are the size of the little finger to the first joint and they are no longer erect, but bend over and hang downward. From the middle of September to the middle of October, according to the kind of spruce and its location, the cones reach their final size, usually between one and two inches long; the seeds undergo the finishing touches of the ripening process; their coats dry and glaze; the little channels through which they received nourishing fluids from the mother-tree are cut off. Future spruce trees are about to be separated from all parental trees and to be thrown out into what may prove for most of them a very cold and hostile world. However,

before we follow a little spruce imbedded in the seed farther in its career, let us turn aside to some general considerations of seed production.

## **When Trees Bear Seed.**

The age at which a spruce tree begins to bear seed varies with the conditions in which it grows. In open pastures and old fields fully exposed to light and in good soil a tree may produce seed when only fifteen or twenty years old; in plantations and pure stands of second growth, cones may appear when the trees are thirty years old, but full production begins at about forty years of age. Under ordinary forest conditions a tree does not bear seed until it frees itself from the shade of its neighbors and receives full light exposure in its higher branches, that is, until it gets into the upper forest crown cover. This happens in a virgin forest where the spruce is associated with hardwoods, usually not before the tree is five or six inches in diameter. According to growth studies made in Quebec in a mixed forest (hardwoods and softwoods) a red spruce tree at that diameter would be close to one hundred years old.

When a tree breaks through the forest crown cover and gets up into the light, under the stimulus of additional exposure to the sun, it develops an increased number of branches, especially the small side branches on the main limbs. As foresters express it: "The crown thickens". When the crown is thickest, there is the largest number of small branches. The cones are borne on these small branches and, therefore, this is the time of greatest seed production. This comes in the mixed forest when the spruce tree is about one foot to one and a half feet in diameter, or in other words, when the tree is between 150 and 200 years old. From this time on the vigor of the tree usually declines and with it seed production, but it is maintained to an advanced age. In the summer of 1917 I cut a red spruce over 300 years old and it had a peck of plump cones on its branches. If we assume, as above, that this tree began bearing at 100 years of age, then it has had over 200



years of seed production! It is probable that the average spruce tree in the forest bears seed for at least 100 years.

How many bearing trees there are per acre or square mile under average conditions and how much seed they produce in a fruiting sea-

son, we don't know. This is a very interesting, not difficult, subject for investigation, and is of direct economic importance.

Thus far, however, no definite study of seed production of spruce, or of any other commercial timber tree, has been made in Canada.

## LUMBERMEN AND THE TREE SUPPLY

By *W. Gerard Power.*



### President of Canadian Lumbermen's Association Champions Progressive Policy in Forest Perpetuation.



To ask a practical lumberman to speak on Conservation is putting a difficult task indeed before him. His every energy is as a rule bent on felling more and more trees, on bringing more and more logs to his mill, on sawing more and more lumber, so that he may give satisfaction to his employers and shareholders, and be deemed a success in the opinion of his fellow-members of the profession.

His basic idea is the more production the more dividends, the more dividends the more honor, not to speak of material advantages.

It is difficult indeed to blame him. In years gone by when the trade was young in this country, it was generally believed that our forest supplies were illimitable and inexhaustible. The idea that the day would ever come when the United States would find itself with its stores on the verge of exhaustion, and the words of a celebrated British authority, Mr. M. C. Duchesne, F.S.S., "Canada contains the only vast resources of timber within the limits of the British Empire," never entered the heads of these pioneers who with their sturdy bushwackers roamed the forests heedless of waste, and extravagant in method, driven thereto by the one principle, "To get the logs to the mill, and to get the best."

It is not for us in this generation to criticize the methods of our forefathers, and to suggest that their management of the woods was not on the right lines, or their system of forestry unsound.

#### The Debt to the Lumberman.

Other times, other manners. Who in those days could guess that Canada would one day be called upon to supply timber to the entire world, and, moreover, if the methods of the old

times were not so scientific as ours, justice forces us to admit but for them a great portion of the country would still be undeveloped, roads unopened, and towns and villages as yet unfounded.

A number of the provinces without their activity and industry would have with great difficulty found means of increasing year by year grants for education, social work, and general development. (Since 1867 the Province of Quebec has derived from the forests the sum of \$42,000,000.00).

Millions of dollars spent in wages and construction would never have been attracted to the country, and further it is hardly likely that this Canada of ours would have been so well known to the world as it is to-day.

So much for the past. The trade and its members have been great factors in the upbuilding of our nation, and we have reason to be proud of it and grateful to them.

#### The Call of the Future.

We must look at the present and to the future. To-day the business of production of wood material is the second greatest industry in Canada. What will it be to-morrow? We belong to an age of optimists, and though the bloody carnage in Europe and its consequences have necessarily oppressed us during the past four years, now that the high sun of Victory is shining in the Heavens and the Angel of Peace has descended over the world, we feel ourselves warmed and invigorated, ready to face the future with hope and confidence.

Every nation on earth freed from the horrid nightmare which has oppressed it, is taking stock and preparing to face the future. The national resources are being carefully investi-

gated in order that every available asset may be put to the utmost practical use.

We in Canada have our Re-construction committees, our Scientific Research Commission, and other bodies established for the purpose of directing the nation's most efficient efforts in the best channels.

### What of Replacement?

And so it should be with the forests. What have we got and what are we going to do with it? Are we to look upon our forest as the miner looks upon his underground treasure, or as the prudent husbandman looks upon his farm? Are we to keep on taking out without any hope of replacement, or are we by a wise and systematic cultivation to perpetuate one of the country's greatest assets?

In one direction we have made remarkable strides since the foundation of the "Canadian Forestry Association", by Sir Henri Joli de Lotbiniere and certain other kindred spirits in 1900. Since that time it can be safely said that the Government and lumbermen have vied with each other in spending their time and money for protection against fire to such an extent that we can see the day, when in the not far distant future, the forest fire losses will be reduced to a negligible minimum.

There is no doubt but that the hand of man has in recent years rapidly decreased our available supply of forest products. This has been brought about partly by the greatly increased demand for lumber from all over the world, and in particular from the United States, and by the immense strides made in the pulp and paper business which must, in order to feed its grinders, and eventually by means of newsprint paper spread knowledge and education abroad, have at its disposal thousands of cords of spruce and balsam.

### Gold and Timber.

The words of John Evelyn are as true to-day as they were in bye-gone ages: "We had better be without gold than without timber," and if it is useful in every art and trade then surely a nation as a whole must interest itself in the welfare of its citizens.

The objection has often been raised that in this country as well as in the United States we are too fond of saying, "Let the Government do it". So it is in this case. On the state, of course, devolves the supreme responsibility for its own sake, as well as owing to the fact that annually \$7,000,000 are collected from the limit-holders of Canada. But there must be co-opera-

tion and assistance even to the point of pecuniary sacrifice on the part of all classes, and in particular on the part of that class which is deriving a material benefit from the exploitation of the forests.

### The Task of Governments.

Speaking as a Quebec limit-holder, I may say that the help which the individual lumberman can give to this work is not very great. The fact that the settler may within a short time clear the land completely of all timber is scarcely encouraging, even if one had the means to systematically carry on a programme of forestry. So that the work must be undertaken by joint effort and co-operation with the governmental authorities, and the first step is, I think, incorporated in the resolution which I am about to propose to you.

Would it not be well, before going into this matter any further and taking any steps which we might afterwards have reason to regret, to find out exactly what we have. How much timber is there in this Canada of ours? We have figures given by various provinces, but they are at best only approximate. As nearly as can be made out, the area given as forest area includes everything which is not town lots, mining leases, or cultivated land, and with the exception of the largest lakes no account is taken for water, and further, the barren lands to the north would seem to be included. Such a condition of affairs can hardly surprise anyone. With one exception no Government has as yet undertaken a thorough and systematic survey of the forest lands under its control.

### What's in the North?

Who knows, for instance, the quantity, the quality of the different species which lie in Ungava, or in the great north land of Ontario? What are the means of transportation therefrom? Is the timber accessible? Is the exploitation of that country a commercial possibility?

The Province of New Brunswick has already undertaken such a survey, and in the words of Mr. G. H. Prince, "It will give definite information of the quantity, quality and value of the timber on any area, from which the stumpage value may be determined. It will show the quantity and quality of species now of little commercial importance because of lack of market demand, and possibly it may show that these species can be marketed profitably, or where quantity justifies it, to induce industries

utilizing these inferior species to operate within the province, thus profitably utilizing material which is at present going to waste.

"Second: The estimate of the annual growth will determine whether or not the annual cut can be increased, or whether to perpetuate the industry, restrictions should be placed on certain species to regulate the cut.

"Third: The information on soils will permit of directing settlement to districts offering the greatest prospect of success, and withholding non-agricultural land from settlement, thus protecting both the future settler and the licensee."

Besides all classes are interested in such a proceeding. The lumberman in order that he may know whether or not he has somewhere else to turn when he has exhausted his present holdings; the state because it is to its interest to know exactly what are its assets; the investor in public securities to know what guarantees his bonds; and, finally the people of the country in order that having the figures before them they may be enabled to check with a jealous eye the means being taken to preserve to posterity their national heritage.

*From an address given before the Canadian Forestry Association at Montreal, January 29, 1919.*

## WASTING THE PRAIRIE PROVINCE FORESTS

For years, the Canadian Forestry Association and the Commission of Conservation have strongly urged that the prairie provinces of this Dominion deserved better treatment than to have their forest possessions rapidly depreciated by unregulated exploitation.

The time has now arrived when in the midst of a national programme for organizing the country's wealth-producing powers, the continued sacrifice of the West's own timber supply can hardly be permitted to continue.

When the Dominion Forestry Branch was first organized, the Dominion Government's obvious intention was to give the then "Superintendent of Forestry" supervision of licensed timber berths. This has become a dead letter. The timber berths are operated by the "Timber and Grazing Branch" of the Department of Interior, and on these large areas (approximately 6,680 square miles\*) there is little, if any, attempt to impose those forestry regulations which alone can maintain these areas as sources of timber supply.

THE DOMINION FORESTRY BRANCH IS A FOREST CONSERVATION DEPARTMENT, by which the Dominion Government, as controller of the timber resources in the prairie provinces and the "railway belt" of British Columbia, seeks to protect and improve the Forest Reserves amounting to 25,000,000 acres. Note the anomaly! While the Forestry Branch institutes measures of conservation on its own limited domain, creates forest nurseries and plants millions of trees, the most valuable bodies of public-owned timber in the West are without any regulation whatever. The principles of conservative lumbering are not observed, because the commercial operator has no need to observe them.

In other words, the Dominion Forestry Branch with its field staff of technical men, is debarred from the forest where it should operate. It practices Forestry on the least valuable areas. The really valuable part of the timber resources of Manitoba, Saskatchewan and Alberta is outside its jurisdiction.

What is the remedy?

Give the Dominion Forestry Branch supervision of logging operations on the licensed timber berths now handled by the Timber and Grazing Branch. It is a simple formula, easily filled by the Minister of the Interior in whose progressive spirit the Forestry Journal has full confidence.

\*Timber licenses in

|   |                    |
|---|--------------------|
| Manitoba  | 1,241 square miles |
| Saskatchewan  | 1,672 square miles |
| Alberta   | 2,027 square miles |
| Also 651 square miles under permit to portable sawmills, cordwood operators, etc. |                    |

## DOES THE WEST NEED FORESTS?

### Destructive Policy on Timber Berths Can Easily be Corrected by Dominion Government.

There has been generally in the public mind in Canada an impression that forestry included mainly or almost entirely protection of the forests from fire and the planting of trees. But this is no more the case than to say that farming is protection of the crop from fire and the seeding of the farm. Farming involves a careful consideration of the area the farmer has available for his farming operations, the quality of the soil, the climatic, moisture and other conditions, facilities for reaching markets, rotation of crops and many other things too numerous to mention. The protection of the crop from fire and the seeding of the ground are two essential points in farming, but no person who knows anything about farming would attempt to reduce it to such simple elements. The time when the scientific farmer was the laughing stock of his neighbors has long gone by, and every farmer who makes a success of the business now recognizes that farming is a science and the returns are the result of thoroughly acquired knowledge applied to a variety of conditions and operations.

#### What is Meant by Forestry?

That forestry is a science, that its operations are complicated, that they are based on accurate knowledge of the conditions of growth of a forest, its relation to the climatic, soil and moisture conditions, the interrelations of the various species of trees and a thousand other things that are not considered in ordinary lumbering operations is a well-established fact in European forest administration, and the public fully second all the efforts of the forest services to improve the condition and productiveness of the forests. The success of forestry in Europe is largely due to the general and intelligent support of public opinion, and until public opinion in Canada has reached a similar condition the development of forestry proper can never be put on a thorough, first class basis.

In every country in Europe the value and production of the forests have been increased by intensive management, the greatest progress being made in Germany, where the average yield of wood per acre was raised from 20 cubic feet in 1830, to 65 cubic feet in 1904. During the same period of time it trebled the production of

saw timber got from the average cut, which means that the timber lands of Germany are three times better in quality on account of the forestry methods followed.

#### Results in Switzerland.

In Switzerland also the development in forest management has been marked. A good example among the Swiss forests is found in the Commune of Couvet, canton of Neuchatel, where the forests have for 30 years been in charge of a trained forester. From 1883 to 1913 the annual cut increased from 3 to 9 cubic meters per hectare; that is, it trebled. And this result was obtained without any decrease in the standing timber which in fact slightly increased during this period. Moreover, the proportion of large timber—the most valuable—which in 1883 was only 18 per cent is now 30 per cent, and the proportion of large timber cut annually has increased from 56 per cent to 69 per cent.

If the policy is adopted that was followed for some time in German forest administration, particularly in some districts, of allowing a planted forest to grow to maturity and then making a clean cut of everything, providing for re-establishment of the forest by replanting the area with young stock grown in a forest nursery, the process is comparatively simple, but foresters generally and even German foresters have been looking around for a more general adoption of less artificial methods.

#### The Method of France.

The forest service of France is as good an example as any of a service which has consistently tried to favor natural methods. The forests of France, once established, are generally reproduced by natural methods. This involves further considerations in timber operations than how much can be obtained from the forest. It involves a knowledge of the year and time of the seed crop, the carrying out of operations so as to get the forest floor in best condition for the reception and germination of the seed, the provision of shelter for young plants easily subject to frost damage, the thinning of the stand to assist clear and upright growth and prevent crowding, and many other considerations affecting the growth of the forest.



Note this fine tangle of debris left on Saskatchewan lands adjacent to the Porcupine Forest Reserve, but completely beyond control of those responsible for the Reserves. (See accompanying articles.)



In contrast to the picture at top of page, this shows how the forests inside the Reserves, under the Dominion Forestry officers, are administered. The dangerous brush has been disposed of. Photograph taken on Porcupine Forest Reserve, Saskatchewan.

It will be seen therefore that the protection of forests from fire and the planting of trees, while essential parts of a forestry programme are only preliminaries to the real work and are the simpler and less intricate parts of the problem.

#### **Faults of Present System.**

As a matter of fact, so far as Canada is concerned, there has not yet been a thorough effort made to practise real forestry. The Governments have been concerned chiefly with the collection of public revenue and the prevention of forest fire, and the regulations intended to ensure the perpetuation of reproduction of the forest are frequently based on erroneous or incomplete information and generally they are not enforced or only partially so. Such regulations as a rule consist in the fixing of a diameter limit below which trees are not allowed to be cut. The effect of such regulations, when observed, has been to change white pine limits to spruce and balsam fir, and it is now changing spruce and balsam fir limits to limits of hardwoods and faulty balsam fir. This is clearly shown by the investigation made recently in the St. Maurice Valley by Professor C. D. Howe, of the Forest School of the University of Toronto.

The lumbermen have ideas of their own as to how cutting should be done to ensure the perpetuation of the forest. These views, however, are generally not the result of thorough investigation on the ground, but from some example which may have occurred in different conditions and the results of which may not be generally applicable.

#### **Good Intentions Thwarted.**

When the Forestry Branch of the Canadian Department of Interior was organized in 1899 the protection of forests against fire and tree planting on farms on the prairies were two matters that were specially emphasized, but the Order in Council dated July 29, 1899, provides that the duties of the Superintendent of Forestry shall be: to inspect the timber reserves in Manitoba and the North-West Territories already defined by the Department of the Interior, to visit the timbered portions of Dominion lands with the view of setting apart further reserves, to look into the report upon the cause and effect of fires and suggest the means whereby the destruction of the forests may be lessened, and also any other duties in connection with the timber resources of Dominion Lands and Indian Reserves he may be called upon by the Department of the Interior to perform.

It was evidently understood from the first that the Forestry Branch would so direct the administration of the forests of the Dominion that

in time they would be thoroughly protected and would be so administered as to reach the highest figure in production.

#### **Canada the Loser.**

As things have worked out, however, the administration of the best timber areas on Dominion Lands has been left under the administration of the old timber office which has in view mainly the collection of revenue and the timber operation and with almost no regard for the conditions that will follow the operations or for the production of a new crop. This means that the present crop of mature timber which does not cover more than thirty per cent of the area usually shown as timbered is being steadily reduced every year without any careful consideration of what is to follow or how the crop is to be perpetuated.

#### **This Rule a Failure.**

The diameter limit for cutting trees is intended as a step toward perpetuating the forest but even if enforced is found to be an utter failure in most conditions. Its success depends a great deal on the original composition of the forest and on how the selection of trees for cutting is made. In many cases where there is much strong wind a selection system of this kind is an utter failure for the trees left usually go down with the first wind storm. In such cases a system where small compact blocks of forest are left has to be substituted.

#### **First Considerations.**

Before any tract or forest is put up for sale or operations authorized on it thorough information should be obtained on the following points: (1) The probability of a market for the products; (2) the conditions of climate, wind and soil; and (3) the composition of the forest as to tree species and the relations they serve toward one another. It is only after information of this kind, which will vary considerably on every tract of forest, has been obtained that the formulating of a proper working plan designed to perpetuate the forest and increase its production is possible. Operations under the Forestry Branch in timber on the forest reserves which was not disposed of prior to the establishment of the reserves are now being carried on on the principle last outlined and the sooner such methods are adopted generally for forests on Dominion lands everywhere the greater hope there will be for the future of the timber business on such lands in Canada and the nearer we will come to a proper administration of this great natural resource.

## “AN ETERNAL SOURCE OF WEALTH”

London, 29th January, 1919.

To Canadian Forestry Journal:

The forests of Canada represent one of the mighty factors in the wealth and in the character of our Canadian countrymen. Scientifically renewed, our forests are and will be an eternal source of wealth. No country in the world has greater possibilities in this respect than the great Dominion, and, whether the future of the world be peace or war, the timbers of our country have destined us to be one of the great decisive factors in the progress and development of the world.

Yours sincerely,

HAMAR GREENWOOD, Col.: Bart: M.P.

## THE WASTE OF CHRISTMAS TREE EXPORT

*By J. A. Bothwell, President Canadian Pulp and Paper Association, in Official Address.*

“There is one other subject to which I should like to direct attention for a few moments and that has to do with the question of our raw material. I am not going into an abstruse discussion of the subject, although it is of sufficient importance to justify a great deal of attention and consideration, but I do want to allude to one or two facts in connection with it. We are all aware of what has befallen the paper-making industry in the States through a too prodigal use of their pulpwood. We are aware, too, that our own supply of pulpwood is being consumed at an alarmingly rapid rate. I do not refer solely to its employment for the legitimate purpose of conversion into marketable commodities, so much as to its export in its unmanufactured state and particularly to its wanton and unnecessary destruction for no good purpose whatever. Every year, thousands of young but valuable spruce trees, owned, it is true, by settlers and other private individuals, are chopped down, their tops cut off and sold for a few cents apiece and carted off to our towns and cities there to

serve for an hour or two's festival use. Not only is this an unnecessary waste of good material, but it also denotes short-sighted economy upon the part of the land owners who permit it to be done. These young trees potentially have a much greater value than is represented by the price paid for them when used in this way. In a few years' time, left to develop, they would have a market value many times greater than in their undeveloped state, while, at the same time, their use as raw manufacturing material would contribute to the welfare of all. We are continually being urged to employ scientific methods in tree-cutting and to replant as far as is practical in order that there may not be a complete exhaustion of the supply, but here is a case where young growing trees are needlessly and uselessly sacrificed by the thousands, apparently without any one raising the least objection. Our forestry departments could do no better service than in putting a stop to the practice.”

## PICTURES THAT TELL A HUMAN STORY

In the photograph at the top of the page may be seen the consequences of stripping timber from land that cannot possibly be utilized for farming. However, an innocent farmer has made the attempt. After expending time and labor and capital he has been driven away by poverty. The land lies bare and useless. It will remain part of Canada's vast "No Man's Land" until replanted with trees. (From a photograph taken in North Saskatchewan).

The lower picture, taken in New Brunswick, illustrates another kind of treatment for non-agricultural soils. It is practically the same character as that in the top picture, but note the contrast in the service it renders the community. Here we find part of a great army of busy lumbermen. They are helping to extract from such Canadian areas \$200,000,000 worth of forest products each twelvemonth. The land is useless for farming, but of splendid use for timber crops, a great power in employing men and meeting the daily needs of the nation.

The top picture need never have been made possible if classification of lands had preceded settlement. To the farmer belongs every acre that will produce crops. That leaves about two-thirds of the Dominion unfit for farms, a large portion of which truly belongs to forest production for all the centuries to come.

## TAKE STOCK FIRST—THEN MAKE PLANS!

Dr. Howe, of the Faculty of Forestry, Toronto University, speaking at the Montreal meeting of the Canadian Forestry Association, said:

"The only way we can ever know just how much spruce we may have for pulpwood is by taking an actual survey of the forests, to find out what conditions really are, over a sufficient area, so that our conclusions may be as nearly accurate as possible. We know that at the present time all our figures are more or less guess work. They may be right, they may hit the mark, but some of us believe they are otherwise, and that the estimates are exaggerated; but as foresters we do not care to make estimates until we have seen, or until we have studied a sufficient amount of the country, so that we have the data to prove the same. All I can say is that my knowledge of the spruce coming in is limited to the St. Lawrence valley, and wherever we have the spruce mixed with hardwood, maple and birch, we will be very much disappointed thirty years from now when we go back there and expect to cut a large crop of spruce.

I do not believe that on the area which I have studied, that in thirty years there will be

enough spruce on those lands to pay for the lumbering. The great need at the present time in the Province of Quebec, and the whole of the Dominion of Canada is a forestry survey, an actual survey estimating as near as possible the standing timber we have here, so that we can make a reliable estimate of the future production."

### THE ROAD OF DESTINY.

"Canada's commercial destiny is chained to the natural resources; the land, the forests, the mines, fisheries and water powers. Superficial activities (with the dice loaded against us from the outset) have cost us heavily in wasted time, wasted legislation, wasted public money. The forest, of course, is a poor advertiser; it cannot speak for itself. And many of those who did speak for it had far better have held their tongues. Nothing has damaged forest conservation so deeply as the circus-poster claim of 'inexhaustible resources'—a boast ironically illustrated by vast tracts of pillaged timberlands." —From "The Forests of Canada."





(See top of opposite page.)



# VICTORIA LAUNCHES INTO STATE FORESTRY

By H. R. MacMillan, Former Timber Trade Commissioner  
for Canada.



All Lumbering is Under Strict Supervision.  
Government May Erect Mills or Buy  
Ships.



Victoria which has been, up to the present, the most progressive Australian state in matters of forest policy, passed through both Houses Dec. 19, 1918, an important Forest Act.

Victoria is a state with great forest possibilities. The total area of the state, 56,000,000 acres, includes 12,000,000 acres of woodland, including much rough and mountainous land, unsuitable for agriculture, which nevertheless lies in a climatic belt where forest growth is varied, and rapid. The forests of Victoria have been the most valuable and extensive of Australia.

## 4,000,000 Acres in Reserves.

During the past five years, under the leadership of Conservator Hugh Mackay, the pioneer of Australian forestry, the forests of the state have been carefully examined and a start made toward training and building an organization for forest protection and administration. About 4,000,000 acres of forest have been set aside by Act of Legislature as permanent reserves for the protection of water supplies and production of timber; of this area, 2,500,000 acres are on high mountain slopes where protection of water supply is of chief importance; another 500,000 acres are cut-over lands in the populated sections of the state. Logging operations are confined chiefly to 500,000 acres, cutting on which is under strict state supervision, the areas being worked on the selection or coppice systems chiefly. A chief feature of the new act is the provision for the appointment of a state forest commission of three members, removable only by a resolution of both Houses of the Legislature, in whose hands will be placed the extension and administration of all state forests, plantations, and forest schools. In the true Australian spirit the Act authorizes the commission to undertake and operate any works necessary for the logging of the state forests or the further manufacture of forest produce, specific powers assigned to the commission being to "Convert any forest

produce into merchantable articles and sell the same"; "construct and maintain tramways . . . purchase, rent or charter vehicles or vessels"; "construct, purchase or rent and operate saw-mills, other mills, dry kilns"; "purchase cattle and pasture them".

The commission is allowed by statute five years in which to prepare working plans for the various state forests, these working plans to become operative when approved by the state cabinet, and not to be revised until they have been in effect at least four years.

## Novel Financing Scheme.

A striking feature of this Act is the novel provision made for financing the forest policy outlined. It is enacted that beginning with 1919 there shall be made available each year \$200,000 for forest expenditure, and that further, when the forest revenue of the state exceeds \$400,000 annually, one-half of such revenue is set aside for the use of the Forest Commission.

The forest revenue of Victoria in 1913 was \$250,000, and the forest expenditure \$285,000.

## Power to Expropriate.

Under powers granted by the Forest Act the Forest Commission may take compulsorily any land required for the proper working of state forests, the protection of state forests or plantations, or the prevention of erosion.

The many species of acacia and gum in Australia have been very loosely named and graded in the Australian lumber trade. The commission has power to establish legal names and grades and to enforce such in all transactions in Victorian timber.

A period of three years is placed by legislation, at the end of which the commission shall have examined the remaining forested mountain areas of Victoria and recommend whether or not they should be constituted state forests.

The importance of forestry in Victoria may be judged by the fact that this state, population 1,400,000, which could readily grow the greater part of the timber requirements, imports from other Australian states and other countries about 200,000,000 feet of lumber annually at a cost of about \$6,000,000.

Foresters in Canada will learn with interest that the chairman of the commission will receive \$5,000 annually, the other two members \$4,000 each.

## FREE SERVICE TO RETURNED SOLDIERS

The Canadian Forestry Journal will be glad to publish, free of charge, advertisements of returned soldiers desiring employment in any branch of forestry work.

Employers are also invited to publish, free of charge, whatever vacancies exist. Government forestry departments may use the columns of the Journal to make announcements concerning vacancies.

All readers are asked to co-operate in this service by reporting new undertakings that may provide employment for returned men.

### HALF OUR FORESTS GONE.

"Repeated forest fires are producing similar results on thousands of square miles throughout the Dominion. One-half of our commercial timber lands have been burned. Even if there never were another forest fire, one-half of our future supply of timber should come from these burned areas. Every fire decreases that possibility by destroying the young commercial trees. We have not only killed the commercial, revenue-bearing trees on one-half the timber-producing area in Canada, but our forest policy has been such that we have virtually decreed their children shall not live." Dr. C. D. Howe.

They are now using airplanes and wireless in forest fire patrol work, but have not yet been able to figure out any effective way for utilizing submarines.—American Lumberman.



Photo by B. R. Morton  
AN ARBORIST NEEDED HERE!

Shade trees in many Canadian municipalities are treated by the local works department as if they possessed the same characteristics as telegraph poles. In the above photograph, taken on an Ottawa street, the trees have been tightly cemented about the base, instead of being given a circle of clear soil. The inevitable usually happens. The growth of the tree bulges the pavement, or the tree dies.

### THE DEATH KNELL OF PINE.

Dr. C. D. Howe examined 80,000 acres of cut-over and burned-over pine lands in the central portion of old Ontario and found 110 young pine trees on the average acre of areas burned over once; 14 pine trees per acre on areas burned over twice; 7 pine trees per acre on areas burned over three times, and only 3 pine trees on the average acre of areas burned over four or more times. It will take several hundred years for nature to restock these areas with pine.

### NEW PUBLICATION FREE TO ALL READERS

The Canadian Forestry Association will be glad to send to its members and friends free copies of a 16-page brochure: "Canada's Forests as an Imperial Asset", by Robson Black. The article appeared in the last issue of the University Magazine.

## PAY NO DIVIDENDS OUT OF CAPITAL

“After the survey of our lands has been completed by the foresters, if it is shown we are lumbering to a greater extent than our annual increment, the Government will consider the curtailment of the present annual cut of lumber to correspond with the natural growth.”—A statement by Hon. E. A. Smith, Minister of Lands of New Brunswick.

## THE PROBABLE COST OF AEROPLANE PATROL

*The Forestry Journal prints the following as a purely military estimate of the cost of an aerial patrol in Ontario. The initial programme calls for an elaborate organization. Whatever is done in air patrol of forests will likely commence with one plane, sufficient to demonstrate a few facts before any Government is committed to huge expenditures.*

Some time ago the Ontario Government asked the Canadian Air Force Headquarters at Argyle House, London, to outline a plan of aerial patrol for the forest regions of Ontario. A cabled account of the estimate claims that three times the area would be covered as under the present system. The cost is given as \$375,000 a year in addition to a large initial expenditure. This, it may be emphasized, takes no account of the maintenance of a very large “land force” of rangers, such as will always be necessary. The Ontario Forest Service has now over 1,000 men on duty and is costing the province about \$500,000 a year, including expenditure on permanent improvements.

The London despatch states:

The cost of such an air patrol would be about \$375,000 a year, and an initial expenditure of \$351,000.

The detailed estimates supplied by Argyle House are as follows:

|   |              |
|---|--------------|
| Estimated cost aerial equipment...  | \$351,312.00 |
| Estimated annual cost of replacement and upkeep of equipment due to bad crashes, forced landings, etc., will not exceed .....     | 155,361.16   |
| Annual charge for pay and allowances, estimating that the service will be maintained for a period of six months in the year ..... | 220,000.00   |

Total annual charge for upkeep,

pay and allowances ..... 375,361.16

It is estimated that this service will be able to patrol an area of 150 to 200 miles in width, and 300 to 400 miles in length, or a total area of 30,000 square miles, with an annual charge of patrolling this area of 30,000 square miles of approximately \$12.50 per square mile.

### Fight Flames From Air.

Not only can the fires be located by the aviator, but they can be fought as well. From dawn to dusk every day for the six months in the year when fires rage in the valuable Northern forests, a ceaseless watch could be kept by air.

Here is how it would work:

At two o'clock in the afternoon a patrolling seaplane, manned by a pilot and observer discovers a new fire commencing. After a quick, thorough reference to maps, the observer sends by wireless the map location of the fire, its magnitude and the necessary method of fighting it.

This message is picked up at once back at the aerodrome or base of the aeroplane or seaplane—whichever is in use. At this base is standing-by a crew of trained forest-fire fighters. Here takes place a rapid reference to maps, and in a few minutes the machine is off in the air with its pilot and six men to fight the fire.

At three o'clock the fire fighting squad is at the scene of the fire, and before darkness falls the fire is put out or is safely checked.

The present method of fighting fires is as primitive as travel by horse and buggy. A fire may get far beyond control before discovered, and by the time a crew of men to fight it has collected, it is of too great a magnitude for checking.

A complete and geological photograph of all this huge area can also be made, which would be of inestimable value to the Ontario Government.

#### Air Force to Operate.

The Canadian Air Force would take responsibility for the administration and operation of the service, and the supply of necessary training of personal and other ranks.

The organization would be as here outlined: (1) One seaplane squadron with its headquarters at North Bay railroad; (2) Three detached flights of six aeroplanes, each located on one of the three railway lines emanating northwards and westwards from North Bay.

The patrolling seaplane would carry a pilot and observer for locating all fires, and the larger flying boats would carry the pilot and six passengers for fighting the fires. The organization of machines for one squadron would thus be: 16 seaplanes for patrolling, and two large flying boats for carrying fire-fighters and their equipment.

The whole of the organization would be in constant communication by wireless, and machines on patrol can be ordered to return or proceed to other points as the administration at North Bay considers necessary.

A great possibility of this, too, is the opening of rapid communication by mail between North Bay and James Bay, as there would be every day spare machines and pilots not on aerial patrol.

It would also serve as a means of giving quick assistance and supplies of food and clothing to devastated areas and districts in Northern Ontario, which are not served by any means of communication with the outside world except by canoe.

#### A BUSH TO EVERY FARM.

(V. A. Hart, in Toronto Globe.)

"I would like to see it made compulsory for every one hundred-acre farm to carry at least five acres of live bush. Outside of the value of the dead or old wood for fuel, the natural moisture would be conserved. Many of our old Ontario counties have practically no bush, and

creeks which were large forty years ago have a struggle to keep going throughout the summer. Then, again, almost every county in Ontario has hundreds of acres of dead or non-productive areas, which once produced a heavy crop of timber, and without timber they are useless (unless the Government wanted it for any purpose). They could be made to produce as they once did. Then in sections in Muskoka, Parry Sound District, Nipissing, and even in Algoma, thousands of acres could be re-seeded or planted to timber again, and with our past experience it would not be so ruthlessly slaughtered as in the past. The farmers for a few years can get to market on the roads as they are being made from year to year, and the money spent to greater advantage for farmer, town and city chap in the building up of our resources. I would not know a million dollars if I should or could see that much, but one million dollars would do a lot of reforestation."



Photo by R. R. Morton

#### CANADA'S ONLY HARDWOOD-EVERGREEN

The Madrona tree, photographed near Chemainus, Vancouver Island. Ordinarily our hardwoods shed their leaves on the approach of frost and the evergreens, with the exception of the tamarack, retain their leaves or needles.

The Madrona, however, is a genuine hardwood that is non-deciduous.

## THE CREDIT OF STATES

By D. E. Hutchins in "Australian Forestry."

A state recklessly squandering its chief natural asset, its forests, burning yearly hundreds of thousands of pounds' worth of the most valuable timber in Australia—its durable softwoods and blackwoods—(as Tasmania is now doing) cannot, in the credit system of the world, stand beside a state like Victoria that is adopting modern methods of State Forestry and conserving its forests. It is easy for a recklessly governed state to disguise its sins for a time. Visitors come to the towns and see wonderful progress there; an unnatural and forced development, if you will. They are shown picked bits of prosperous rural districts, but there is something behind this, and sooner or later the other side of the picture gets known.

### BELGIUM AND FORESTRY.

Belgium and England are the two most densely populated European states. The Belgian Government, before the war, had a Forest Department of 750 men, and provided winter employment for 32,000 men.

### JAPAN'S GREAT EXPENDITURES.

Japan spent 250,000 pounds sterling (say 1,000,000 pounds on the Canadian wage scale) yearly for many years when the wild forests were being put in order.

## STANDING BY THE FORESTRY CAUSE

There are in the membership of the Canadian Forestry Association thousands of forward-looking Canadians who are eager to assume their full obligation to the future of Canada. They regard their membership as a working force in good citizenship and are eager to keep it in effective condition.

Not content to have their annual fee cover only the cost of printing the Forestry Journal, many of them have chosen to accept a "Contributing Membership" costing five dollars. This provides the Association with funds for its national educational enterprises.

Our lecturers, motion picture films, lantern slides, railway demonstration car, travelling lecture sets, hundreds of thousands of educative issues, our campaigns with governments, etc., are wholly in the national interest and require a constant supply of money. Every dollar is spent with maximum economy, the Association securing thousands of dollars worth of free and valuable co-operation month after month.

On February 15th a number of our members were asked to take a Contributing Membership at five dollars. By March 11th (the day of going to press) the following had gladly responded to our proposal; the list will probably be doubled by the April issue of the Journal:

|                    |                    |
|--------------------|--------------------|
| Sir James Aikins   | John D. Flavelle   |
| F. H. Anson        | Thomas Fynes       |
| Joseph Allison     | Mrs. R. C. Fisher  |
| W. B. W. Armstrong | E. J. Freyseng     |
| Mark Bredin        | Fassett Lumber Co. |
| A. W. Boswell      | Thomas Flynn       |
| John Beattie       | A. B. Gordon       |

|                                      |                                  |
|--------------------------------------|----------------------------------|
| Walter A. Black                      | J. N. Greenshields, K.C.         |
| P. Burns                             | John H. Garth                    |
| Hon. J. P. Burchill                  | Sir Charles Gordon               |
| H. L. Bradbery                       | J. L. Goodhue & Co.,<br>Limited  |
| E. R. Bremner                        | Robt. F. Grant.                  |
| Baird and Peters                     | C. S. Gzowski                    |
| John A. Bain                         | Peleg Howland                    |
| O. B. Brown                          | J. W. Harkom                     |
| W. G. M. Byers                       | A. C. Hardy                      |
| Theo. A. Burrows                     | Grant Hall                       |
| J. B. Beveridge                      | C. H. Johnson & Sons,<br>Limited |
| Canadian Land and<br>Immigration Co. | A. Jephcott                      |
| R. J. Christie                       | Keenan Bros., Ltd.               |
| J. H. Connor & Son.                  | Keewatin Lumber Co.              |
| Geo. A. Campbell                     | Louison Lumber Co.               |
| W. G. Clarke                         | Col. T. G. Loggie                |
| Alfred Collyer                       | Jose A. Machado                  |
| Hugh J. Chisholm                     | Prof. Iva E. Martin              |
| A. E. Cross                          | A. D. MacTier                    |
| H. N. Chauvin                        | E. W. Mudge                      |
| E. M. Dechene                        | Montgomery & Sons Co.            |
| G. Durnford                          | R. A. McInnes                    |
| Henry Detchon                        | F. W. Molson                     |
| R. J. Dale                           | D. McLeod                        |
| W. M. Dobell                         | Sir W. R. Meredith               |
| Edward L. Drewry                     | Paul G. Owen                     |
| H. A. Downs                          | Albert F. Park                   |
| Joe M. Dalton                        | Hon. S. N. Parent                |
| A. L. Eastcott                       | T. M. Partridge Lum-<br>ber co.  |
| Edward Hines Lumber<br>Co.           | Sir William Price                |
| C. E. Edmonds                        | John Penman                      |
| Eddy Brothers & Co.                  | P. D. Ross                       |
| Hon. Sydney Fisher                   | Rideau Lumber Co.                |
| Finch, Pruyin Lumber<br>Co.          |                                  |

## FOR SALE—CHOICE TIMBER TRACTS

One or both; located on Columbia River and Tributaries north of Revelstoke, British Columbia; twice cruised by Marwick, Mitchell, Peat & Co., New York; surveyed by Christie, Hayward & Dawson, Vancouver, B.C.; near interior market; saving in freight over coast shipments two dollars thousand. Do you want high class timber property, if so write

S. A. HOLBROOK, Bradford, Pa., "Owner."

### TIMBER IN M. FEET

| TRACT             | CEDAR       | SPRUCE      | FIR        | PINE       | HEMLOCK                 | TOTAL       | CEDAR<br>POLES |
|-------------------|-------------|-------------|------------|------------|-------------------------|-------------|----------------|
| Downie Creek..... | 204,143,000 | 47,228,000  | 18,186,000 | 7,473,000  | 79,748,000              | 356,778,000 | 60,612         |
| 16 mile .....     | 54,002,000  | 30,687,000  | 2,433,000  | 1,758,000  | 21,012,000              | 109,892,000 | 21,625         |
| 25 mile .....     | 67,468,000  | 39,908,000  | 28,799,000 | 5,068,000  | 47,086,000              | 188,332,000 | 27,642         |
| Goldstream .....  | 33,649,000  | 16,406,000  | 478,000    | 200,000    | 7,577,000               | 58,310,000  | 8,857          |
| 50 mile .....     | 45,890,000  | 34,395,000  | 6,050,000  | 1,155,000  | 20,095,000              | 107,585,000 | 35,360         |
| Schoonmaker ..... | 2,785,000   | 10,851,000  | 1,348,000  |            | 4,108,000               | 19,090,000  | 2,116          |
| (83 miles)        | 407,936,000 | 179,475,000 | 57,294,000 | 15,634,000 | 179,629,000             | 839,988,000 | 156,212        |
|                   |             |             |            |            | Dead and down cedar---- | 25,217,000  |                |
|                   |             |             |            |            |                         | 865,205,000 |                |

### S. A. HOLBROOK (Trustee) TRACTS.

| TRACT         | CEDAR       | SPRUCE      | FIR        | PINE       | HEMLOCK    | TOTAL       | CEDAR<br>POLES |
|---------------|-------------|-------------|------------|------------|------------|-------------|----------------|
| Gaffney ..... | 57,433,000  | 35,534,000  | 15,653,000 | 3,409,000  | 10,168,000 | 122,197,000 | 84,062         |
| 22 mile ..... | 60,880,000  | 67,425,000  | 28,951,000 | 8,233,000  | 74,131,000 | 239,622,000 | 32,569         |
| (34 miles)    | 112,313,000 | 102,959,000 | 44,604,000 | 11,642,000 | 84,299,000 | 361,619,000 | 116,631        |

FOR BIGGER  
AND BETTER CROPS  
**STEELE, BRIGGS'  
SEEDS**  
SOLD EVERYWHERE IN CANADA  
WRITE FOR NEW CATALOG  
**STEELE, BRIGGS SEED CO.**  
"CANADA'S GREATEST SEED HOUSE" LIMITED  
**TORONTO**  
HAMILTON WINNIPEG

## GUARDING 21 MILLION ACRES BY CO-OPERATION

By Arthur Graham, Manager, Ottawa River  
Forest Protective Association.

The fire season of 1918 in the territory of the Ottawa River Forest Protective Association may be classed with that of 1917, as being a favorable one for forest protection. No development of organization will make it possible to leave weather conditions out of conditions out of consideration. The season, however, was not void of extremely dry periods and spells of high winds. The rainfall during the months of July and September, and particularly during the latter, was quite over the average, but May, June and August were dangerous at times.

One hundred and forty-seven fires started in our territory during the season, and of this number 111 were extinguished by the rangers without extra help. The damage to merchantable timber is reported by our inspectors to be not more than 275,000 feet board measure, scorched, and other property valued at \$5,140. The area of merchantable timber burned over is found to be 98 acres.

A careful study of the causes of fires has taught us that more fires are caused by lightning than many are willing to admit. Records for the past two seasons of 1917 and 1918, in our western section, show that 29 per cent of the total fires were caused by lightning. The pine districts are found to be the most susceptible to lightning fires, and especially in old-burn areas where dry pine trees are still standing. These are the hardest to detect, and will often escape early detection unless the rangers are equipped with a system of lookout towers and telephone lines.

### Large Equipment.

The number of permanently employed men for the season was 198, and the inspection was taken care of by 11 inspectors. Our organization like many other branches of woods operation suffered somewhat from men enlisting in the Canadian army, the result being that the personnel of our inspectors and rangers in certain districts did not measure up to the usual standard maintained by this association. Now that the war is over we can hope to improve this situation.

The following is some of the travelling equipment used: 20 horses, 90 canoes, 7 motor-boats, 3 outboard motors, 1 steamer and 3 track velocipedes. During the season two fire-

fighting units, equipped with 1,200 feet of distributing hose was purchased for fighting fires. These were not delivered in time for use last season.

### Settlers' Fires.

Settlers are found in 72 townships where our members own timber licenses, and it is interesting to note that the percentage of fires caused by settlers burning slash has decreased from 51 per cent to 21 per cent. This remarkable change is mostly due to the enforcement of the Burning Permit Law. 1,466 burning permits were issued by our rangers to settlers during the past season. No fires escaped control.

The number of prosecutions for infraction of forest fire laws, has fallen off considerably. In 1914 there were 40 prosecutions, in 1915 39; 1916, 6; 1917 6; 1918, 6.

### Members Satisfied.

Seven new members have enlisted their holdings for patrolment during the last season, adding 119,368 acres to our area. The total membership now is 67, with an area of 17,033,440 acres, (26,614 $\frac{3}{4}$  square miles) of Licensed Crown Lands, including 4,060,800 acres of Licensed Crown Lands which are taken care of by the association, the total area patrolled is found to be 21,094,240 acres (32,959 $\frac{3}{4}$  square miles). The figures do not include timber lands known as Indian Reserves, Seignories, and lots deeded to settlers, etc., joining the association territory, large areas which have to be patrolled by our rangers in order to protect the limits owned by members. It is interesting to note when summing up the area of this vast territory that only two per cent of the Licensed Crown Lands remain outside of the association. These are classed as non-members. Not a single member has withdrawn from this association since its inauguration, unless by reason of sale.

### Co-operation.

The success of the association is due to the Quebec Government by the co-operation of the Hon. Jules Allard, and the officers of the Department of Lands and Forests, to the Canadian Forestry Association for special publicity campaigns and distribution of literature, to the Fire Inspection Department of the Board of Railway Commissioners, and the various bush superintendents, foremen, and others in charge of lumbering operations.





## FOREST TELEPHONES

Make the life of the forester better worth living. They relieve him from the appalling loneliness. They help him to keep in human voice touch with foresters miles away.

In emergencies—fire—sickness—hunger—the speed with which they can summon help is marvellous.

Write for full particulars of how to install the Northern Electric Forest Telephone System. Address the Office nearest you.

*Northern Electric Company*  
LIMITED

|          |          |           |
|----------|----------|-----------|
| Montreal | Toronto  | Regina    |
| Halifax  | London   | Calgary   |
| Ottawa   | Winnipeg | Vancouver |

***Northern · Electric · Forest · Telephones ·***

## A HELPFUL WORD FOR THE FORESTRY ASS'N

The Forestry Journal acknowledges gratefully the following comment upon the work of the Canadian Forestry Association contained in the report of the Committee on Forests of the Commission of Conservation:

"The Canadian Forestry Association has been extremely active in disseminating educational propaganda along forestry lines. This work has extended to all the provinces, but is particularly notable in the east. Through co-operation with the Railway War Board, a special car was provided and equipped with educational exhibits. Lecturers were provided, through co-operation with Provincial, Dominion and private forest organizations, and lecture trips were made to numerous points in Ontario, Quebec, New Brunswick and Nova Scotia. It is to be hoped that this work can be continued, and extended, if possible, to the western provinces.

"The Forestry Association is doing splendid work along many different lines, and is worthy of the greatest possible support from Dominion,

Provincial and private agencies. It has become a very definite force in the direction of getting things done along the lines of forestry and fire protection. Its usefulness would be greatly increased by the establishment of a branch office in the west, possibly at Vancouver, and it is to be hoped that the necessary financial support may be made available to this end.

### MARKING FOREST LAND IN INDIA.

Forest demarcation began in India over half a century ago. As regards land, the situation was similar to Australia when the white man landed. All the land was Government land, and excepting, partially, in one province, has remained Government land ever since. Thus, when forestry was started, the Government had a free hand; and forest demarcation was carried out in the most complete and thorough manner.

## NEW "MUST" WRITTEN IN QUEBEC FIRE LAW

---

The Government of Quebec is about to pass legislation by which limit-holders refusing to join one of the four fire protection associations in the province will be compelled to provide adequate patrol on their lands or have the work done by the associations at owners' expense. This step bridges a very obvious gap in Quebec's fire prevention system inasmuch as certain limit-

holders declined to co-operate in fire guarding or establish a sufficient patrol on their own initiative. The consequences were that in and about the association's areas were blocks of forest offering a constant fire menace and interfering with the continuity and economy of patrol.

## LIMIT HOLDERS TO EXPERIMENT WITH SLASH

---

As an organization unafraid of fresh ideas commend us to the Woodlands Section of the Canadian Pulp and Paper Association. No sooner was the Montreal Forest Conference closed than Secretary A. L. Dawe addressed the following to all the limit-holding companies:

### **What Are You Doing With Your Slash?**

It has been realized for some time that cut-over lands are the greatest fire risk with which we have to deal and also that the decaying slash left on the ground is a breeding place for fungi and bark beetles which are working enormous damage in our woods. This damage is said to be almost as great as that from forest fires.

Try this for the balance of this winter and next season: You are requested to pick out one or two camps in your next winter's operations and try brush burning along the following lines:

Make a fire. A boy can be added to every two logging crews, who on going to work in the morning should start a small fire and the fellers should be instructed to fall the trees as nearly as possible so that the tops may come near the fire. As fast as the trees are swamped, that is the limbs cut off, a boy should gather up the branches and throw them on the fire. When the top is reached a man should help the boy place it on the fire and all should be burnt.

Watch the fire. The location of the fire, as far as possible, should be chosen so that no living trees or at least only a few small ones will be damaged. The fires do not need to be at all large for spruce and balsam as this burns very easily indeed.

Keep a note of the cost. The cost of this operation should be carefully kept and compared with the cost of making logs in similar territory in previous years, also if possible it would be interesting and very valuable to have the actual cost studied at some time during the operation,

so that the time it takes the men to haul and swamp a tree and the time that is employed in putting the brush on the fire.

What do we gain by this? A collection of results from a number of companies would give a very fair average cost of this sort of work. You are asked to give this a fair trial and to impress on your wood foremen that this is not a matter for jesting. You are all familiar enough with the attitude of the men in the woods to realize that unless the seriousness of this is impressed on the foreman, that they will make light of it and do all in their power to push the cost up as far as possible.

Checking up. By having a number of companies doing work along the same lines it will be very easy to pick out the men who have tried to do the work faithfully from those who have not. You are urged to give this brush burning a fair trial and to co-operate in every way possible to establish whether such is practical and economical or not.

Will you let me know that you are ready to help along in this work?

The Woodlands Section has already taken the lead in co-operative work. Let's go further."

## QUALITY OF SOIL IN TREE GROWING.

---

After depth and accessibility (or possible accessibility) the important point coming before the forest demarcator is quality of soil. I place quality of soil after depth and accessibility, because quality of soil is less important in forestry than in agriculture. To a great extent the forest will make and keep its soil; forest is naturally a soil improver, agriculture a soil exhauster. So that as regards forestry and agriculture, forest should occupy soil that is deep and penetrable by roots, but poor in an agricultural sense.—From "Australian Forestry."

Peterborough Canvas Covered and Wooden Canoes are built in all sizes and for all purposes. For Pleasure, Cruising, Trapping or Freighting.



Peterborough Motor Boats, like the Canoes, are built in all sizes and for all purposes. If you are interested we will send you our illustrated Catalogue.



This Trade Mark appears on all genuine Peterborough Craft.

## THE PETERBOROUGH CANOE CO. LIMITED

Peterborough, Ontario, Canada

# FORESTERS!

We want you to know  
all about our

“ARCTIC EIDERDOWN  
SLEEPING ROBES”

It is to your own personal interest and  
comfort to own an Arctic Robe.

—Manufactured only by—

WOODS MFG. CO. LIMITED  
OTTAWA

“Booklets Ready for Mailing.”



## CANADA THE MASTER OF ITS FORESTS

Our forests have a wealth-producing capacity, the possibilities of which, from a long-time viewpoint, have as yet been realized only in small part, observes the Commission of Conservation. To transmute these possibilities into permanent actualities requires, however, the general acceptance, by the people in general, and by Governments in particular, of the fundamental principle that the forest is a crop, rather than a mine, and that cutting operations on non-agricultural lands must be conducted always with a view to the perpetuation of the forest as such.

The practise of silviculture is still in its veriest infancy in Canada, as it is over most of North America. There is still far too strong a tendency toward the practise of forestry anywhere except in the woods. At the same time, it must always be realized that forestry is essentially a business proposition, and that business considerations place definite limitations upon what it is feasible to do in the direction of intensive methods.

On the other hand, the forest lands of Canada are predominantly Crown lands and are therefore, for the most part, the property of the people of the country. It follows that the public interest, from a long-time viewpoint, should govern in determining the conditions under which exploitation takes place. With the present increased stumpage values, many things in the direction of better management are now becoming economically feasible which would have been out of the question in years past.

## THE GARBAGE OF THE WOODS

"Slash is the garbage of the woods; and just as the city garbage must be destroyed to protect the health of the citizens, so should the forest garbage be burned for the protection of the trees. How can we expect the remaining timber to be healthy when each year we distribute throughout the province many square miles of this rubbish, the finest breeding ground for in-

sects and fungi that could possibly be conceived?

"As a preventive and insurance against insect and fungus troubles the slash should always be burned; but at this time, when slash burning will without any doubt go far toward checking the balsam disease in regions where it has only started, and in preventing its development in areas that have thus far remained healthy.

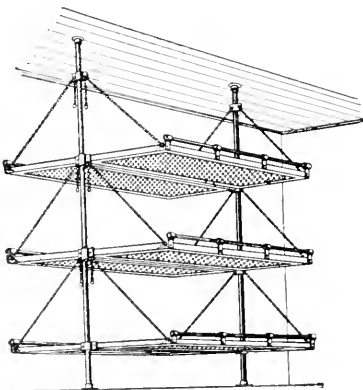

## STEEL BUNKS FOR CAMPS

Included in the well-known line of DENNISTEEL factory, hospital, camp and ship equipment is the all-steel sanitary bunk illustrated. Take up very little room, are comfortable, hygienic and practically indestructible—a permanent investment. Write for particulars and folders on any of the following lines: Steel Lockers, Bins, Cabinets, Chairs, Stools, Etc. Standardized Steel Shelving (knock-down system), Steel Hospital Equipment, General Builders' Iron-work, Ornamental Bronze, Iron and Wirework. Wirework of every description.

**THE DENNIS WIRE AND IRON  
WORKS CO. LIMITED**

**LONDON  
CANADA**

HALIFAX    MONTREAL    OTTAWA    TORONTO  
WINNIPEG                      VANCOUVER



## If you once Shaved Yourself With This Razor-

you, too, would join the ranks of Gillette enthusiasts.

Consider that stocky handle, knurled to prevent the possibility of slipping. There is weight there, to give strength to the angle stroke and ensure the cleanest, smoothest and quickest shave man has ever enjoyed.

Consider the blades, of the finest steel the world produces, wafer thin, and sharpened to an edge that no amateur stropping or honing could hope to approximate.

Consider the case, of Morocco, with two blade boxes to match—compact, complete, convenient.

And consider the price—\$5.00 the set at any jeweler, druggist, or hardware dealer.

THEN, consider for your own use, this

## GILLETTE BULLDOG Safety Razor

**TREES, SHRUBS and SEEDS**

Hardy Northern Trees and Shrubs at Lowest Prices. Native and Foreign Tree Seeds.

**EDYE-DE-HURST & SON, DENNYHURST**

Shippers to H.M. Government, Etc.  
DRYDEN, ONT. Correspondence Francaise.

**Hill's Seedlings & Transplants**

ALSO Tree Seeds for Reforesting. Best for over half a century. Immense stock of leading hardy sorts at low prices. Write for price list and mention this magazine.

Forest Planters Guide Free.

**The D. HILL NURSERY CO.** Evergreen Specialists  
Largest Growers in America.  
Box 503. DUNDEE, Ill., U.S.A.

**Try This Stump Puller at Our Risk**

The Smith Stump Puller will take out every tree and stump by the roots, clearing from one to three acres a day, doing the work of twenty men. We want you to send for our 3 year guarantee against breakage and our free trial proposition. Address  
**W. Smith Grubber Co.**  
11 Smith St.  
LeCrescent, Minn.



ASK



FOR

**GAGNON & MORISSETTE**

TIMBERLAND CRUISERS  
LUMBER CONTRACTORS  
FOREST INDUSTRIES

CHICOUTIMI, - - P.Q.

**LT.-COL. L. J. D. MARQUIS**

Forest Engineer and Mem. Can. Soc. of F.E.;  
Quebec Assoc. of F.E.; Former  
Mem. Que. F. Service

Timber Factors and Logging Costs  
Facts on Forest Growth and Future Products  
Forest Cruising and Mapping  
90 LOCKWELL AVENUE - - QUEBEC

**Timber Lands Bought & Sold**

Timber and Pulp Wood Estimates.

**R. R. BRADLEY**

CONSULTING FORESTER  
Globe-Atlantic Bldg. - ST. JOHN. N.B.

**Timber Estimating & Mapping**

Management of Forest Properties.  
Supervision of Lumbering Operations.  
Forest Planting.

**COOLIDGE & CARLISLE**

FOREST ENGINEERS  
BANGOR - - - - MAINE.

**Timber Estimates**

JAMES W. SEWALL

Old Town, Maine.

**PROF. MILLER AT YALE.**

Prof. R. B. Miller, recently of the University of New Brunswick's Department of Forestry, has been for some time acting as lecturer at Yale Forest School on Forest Management, and State Forest Law. In addition to these duties, Prof. Miller is engaging in special post-graduate studies.

In order to encourage slower eating and better mastication it is proposed to permit lumberjacks to talk at table. If they do, and the straw-boss will stick around, he will probably hear something to his disadvantage.—“The American Lumberman.”

**THINKING OF STARTING  
MOTION PICTURES ?**

For Travelling Lecturers and School Use, the  
“De Vry” Stands in its Own Class.

**It weighs but twenty pounds.**

**Built the size of a suit case, 17 by 17 by  
7 inches.**

**Attaches to any light socket.**

**Takes standard size reels and film.**

**Any size picture up to 12 feet.**

**Any throw up to 80 feet.**

**No setting up; no adjustments.**

**Ready instantly.**

**No special wiring required.**

**Splendidly constructed.**

**Built to endure.**

**Price \$200 complete.**

**Made by the De Vry Corporation, Chicago,  
and sold through the Canadian Forestry  
Journal.**

**Address, Canadian Forestry Journal,  
Supplies Department,  
206 Booth Building, Ottawa.**

In 51 years since Confederation, the forests of our Dominion provided 1,400 million dollars in export sales; cereal crops accounted for 200 millions.

**A Woodman's Canoe**

**L**IGHT, capacious yet compact. Strong durable, capable of carrying big loads—that is the kind of canoe a Forester wants—and that is a description of a

**CHESTNUT CANOE**

Indeed it is the ideal craft for everyone. The woodwork is of the toughest cedar. It is covered with a seamless canvas, in turn covered with an absolutely water-proofing preparation. It is leak-proof and weather-proof.

The pleasures of camping, hunting and fishing are more complete when your equipment includes a Chestnut Pleasure, Sponson, or Cruiser Canoe. You get every kind of service and pleasure out of a Chestnut Canoe including every comfort and safety.

**Chestnut Canoe Co. Limited**

Box 460. FREDERICTON, N.B.

**REFOREST BARE HILLSIDES.**

The scarcity of lumber for mine pillars and other mine uses has led to the creation of a forestry department by several of the large mining companies, one of which has just reforested Bear Creek watershed with 5,000 white pine, and 5,000 Norway spruce trees.

Thirty thousand more trees are in process of cultivation at Hauto, Pa., in the Panther Creek valley. When timber is ready to cut in the vicinity of the mines troublesome waits and long hauls will be eliminated.

More timber in the anthracite region would stop floods, add to the water supply, reduce the drought periods and enable the anthracite industry to add to its output. Many thousands of acres are available about the mines for reforestation.

*"With regard to Trees, I passed part of my youth in the shade of Burnham Beeches, and have now the happiness of living amid my own 'green retreats'. I am not surprised that the ancients worshipped Trees. Lakes and Mountains, however glorious for a time, in time weary. Sylvan scenery never palls."*—Letter from Lord Beaconsfield.

## JACK MINER

(Continued from page 103)

that old leader goes right over them—now he has passed them. There I am under the blanket—possibly it is a sheet if there is a little snow on the ground—the three corners are tied down and I am underneath it, just hidden there, with a gun ready. And the leader swings around, and as he swings around he calls and starts to drop his big black feet to come down. But for some unaccountable reason he changes his notes and climbs into the air—everybody look out for himself; and the minute he changed his note they all darted in as many different directions as there were geese—it was the danger signal. What did he see? He didn't shy from the other fellows, but, he said, that fellow over there knocked out two of my family last year. Two and two make four—if the wild goose knows his enemy why wouldn't he know his friend?

### The Neighbors' Boys.

I have only ten acres, people; how can I protect the geese? There are eight boys around the neighborhood, from five families. I said to them: If you won't shoot at the wild geese around here, I will see that you get a chance to shoot at one in the pond. That was in 1904. In 1905, 1906 and 1907 no wild geese came. In 1908, one morning eleven wild geese came, and they hadn't been there ten minutes before the boys came along with their guns. I said: "Boys, leave it entirely with me; don't shoot at them for a week or two". "But", they said, "you said we could shoot them"? I said, "Boys, if you don't get the opportunity to shoot a wild goose, I will give you ten dollars a piece, if you will let me manage it." They said: "We don't want your money"—of course they knew that I didn't have it. However, in about three weeks, we hoisted a signal, "Go on, boys!" We were behind the bank I had thrown up there.

Uncle Jack was to shoot the two ganders. The boys lined up on one side and cocked their guns, and as they raised them, I made it my business to scare the geese so that the boys wouldn't shoot them. Bang! went their guns. The two ganders got away, but five geese lay dead in the water, one of each family. I asked the boys not to shoot the others. To my surprise and delight, the other six did not stay until the time came for them to migrate. stay away two hours; they came back, and If you get one bird to come, there is your opportunity.

### Moving Day in Birdland.

Next spring it was asked if the geese would come back. On March 18 I heard a strange honking and I looked up and saw that they were coming—32 of them. They came down within 100 feet of us, I walked out and they never flew away. I had the privilege of seeing them introduce their families. The boys shot ten, and that left 22 to go away. Next spring it was asked what time the geese would come back. They started to come on March 4, and in less than two weeks there were over 400 there. The boys shot 16 and let the rest go. Look how our flock of geese has multiplied; now we have a flock of over 350. They started coming on February 20, and when the first was whirling down I counted 175 shots at him between my home and Lake Erie. When the first was lighting in the pond, you couldn't see the end of the string of families that were coming.

### Five Acres of Geese.

I don't know whether you have experienced it, but I have: there is nothing more embarrassing than to have more guests than you can feed. There I was, on Good Friday of 1913, with a five-acre field full of geese. We couldn't begin to feed them. Some of the geese must have told their friends what was not true, and induced them to come to a place where there



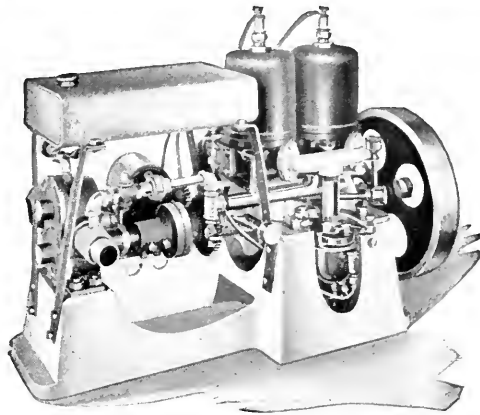

## FAIRBANKS-MORSE FIRE FIGHTING ENGINES

These compact powerful little pumping outfits have repeatedly substantiated our claims during the past year, all over Canada. They can be readily transported wherever man or pack horse can go. Governments and Private Owners of Forests everywhere, can materially reduce their fire losses by the use of these outfits.

Full information and prices on request.

**THE CANADIAN FAIRBANKS-MORSE CO.**  
LIMITED

**MONTREAL - OTTAWA**

ST. JOHN, QUEBEC, TORONTO, HAMILTON, WINDSOR,  
WINNIPEG, SASKATOON, CALGARY, VANCOUVER, VICTORIA.

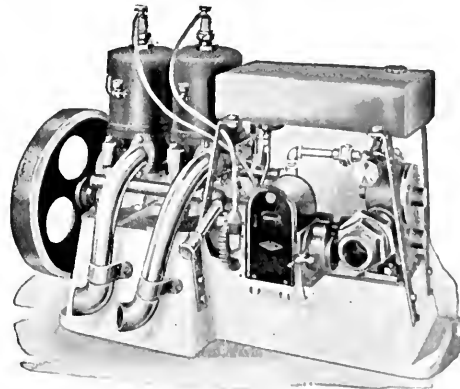

**CONFEDERATION LIFE**  
ASSOCIATION

**UNCONDITIONAL  
ACCUMULATION  
POLICIES**

Are liberal up-to-date contracts which guarantee to the insured every benefit consistent with safety.

**WRITE FOR PARTICULARS**

which will gladly be furnished by any representative of the company or the

**HEAD OFFICE,  
TORONTO**



**QUEEN'S**  
UNIVERSITY

KINGSTON  
ONTARIO

**ARTS MEDICINE  
EDUCATION  
APPLIED SCIENCE**

Mining, Chemical, Civil, Mechanical and  
Electrical Engineering.

**HOME STUDY**

Arts Course by correspondence. Degree with  
one year's attendance.

**SUMMER SCHOOL**

JULY AND AUGUST

**NAVIGATION SCHOOL**

DECEMBER TO APRIL

GEO. Y. CHOWN, *Registrar.*

**R. O. SWEEZEY**

(B.Sc., M.E.I.C.)

WATER POWERS. TIMBER LANDS.

**FINANCING**

164 St. James Street - MONTREAL.

**P. L. BUTTRICK**

CONSULTING FORESTER

**NEW HAVEN, CONN., U. S. A.**

P.O. BOX 607

---

**TIMBER ESTIMATES  
UTILIZATION STUDIES  
PLANTING PLANS**

---

**Landscape and General Forestry Work.**  
Eight years experience in practical  
forestry work of all sorts.

**UNIVERSITY OF  
NEW BRUNSWICK**

FREDERICTON, N.B.

**DEPARTMENT OF FORESTRY**

Established in 1908.

Best of facilities for definite instruction  
and supervision in Practical Forestry.

Surveying, cruising and construction  
work carried on in our own tract of 3600  
acres, with Forestry Camp in the centre.

Competent men from the School at  
present in demand to take up Forest Sur-  
vey work with the Provincial Crown Land  
Department.

For further information address:

**DEPARTMENT OF FORESTRY**

University Calendar furnished on application.

C. C. JONES, *Chancellor.*

was not enough to eat. We brought the feed close to the house and let the tamer ones come there to eat. I was speaking at the Rotary Club in London the other day, and one gentleman asked me how I moved the birds. This was my explanation to him: If you want to move your birds, keep moving the food accordingly, and pretty soon you can put the spoon in your mouth and the birds will alight on it.

I will tell you about one family, one of a dozen interesting cases last autumn. On October 10, six geese came. By the way, we never had over 150 in the autumn. Which way do they come in the autumn. I went out and called to these six geese, and the old gander answered. He knew me. I got twelve ears of corn, and threw one of them at him. Just as I did so the four baby geese jumped into the air, but he called them and they dropped down. Then I threw more ears of corn, and each time the same thing would happen; he would sound that low note, and every time he did so the geese would come down. By the time I had thrown the eighth ear he had convinced them that all was well, and they didn't fly up any more. It was interesting to watch him trying to educate them to take the kernels of corn off the ear, but it was strange to them. He would get a kernel off and drop it down, but it was fully fifteen minutes before he got those goslings to take the corn; when they did start they cleaned off every kernel of the twelve ears. That told me these young goslings have never seen an ear of corn before, and that they had come all the way from Hudson Bay without a mouthful and dropped down there. The old gander had led them all the way down.

### Why "Canada Goose"?

My wife and I coaxed this old gander and his five goslings into the coop and she held the door while I went in and clamped a tag on his leg. After I tagged him I took him to the door and threw him out—this same old gander that had been telling his girls and boys to eat the corn and to stay there and not be afraid. When I threw the gander out, did he fly to the lake? To know the Canada goose is to love him forever, and if there is any person in Ottawa who can tell me how that most intelligent, self-sacrificing bird came to be honored by being called the Canada goose, I wish he would write me. You cannot show me any of his actions that one need be ashamed of, not one.

To resume my story. This old gander went out, and when he was about two rods away he turned around and looked back. You could hear him calling for the rest of his family in that little catch pen. Mrs. Miner at this time would rather have been on the inside looking out than on the outside looking in, because, as I was catching number two, the gander came right back to the door and tried to break in and get at me. We are talking about the same bird that I tried to get a shot at three fields away; here he is now fighting to get at me to protect his young—trying to get his young out. He didn't leave that door until every one of his family had been liberated; he stood right there and fought for them. We caught him the second time, put a cuff on each leg and named him "Sir John Moore". We put on the tag this verse of Scripture:

"No good thing will He withhold from them that walk uprightly".

They migrated as usual, and on March 17 following, the boys said, "Look! Dad," and there was old Sir John Moore looking for more corn, with the two cuffs on his legs. Five of his family had returned; he had taken care of them down in the southern states all winter, and brought them back. The last week in April they disappeared, and my heart sank when I opened a letter from Fort George, James Bay, and found four of the tags. The letter read: "The Indian says that seven geese came into their decoys, and they killed four of them; each one had a tag on it". You know just how I would feel, although that is part of the game. To the fellow who wants to shoot let me say this: I am not opposed to a man shooting a bird or two, but will you not join with us in limiting your gun? Remember, that bird that falls out of the air from your deadly aim gives you and me a little pleasure, but deprives thousands of people of pleasure and recreation in seeing it alive. Let us consider that; let us think it over.

Delilah raised during the six seasons, five families, two of eight and two of nine, and this year she came home with twelve. What does game protection mean? Protect the old duck, and you can quickly figure out what the total increase in six years will be. Delilah returned for the sixth time and she raised these five families. I haven't seen her since August.

### The Drake's Bad Character.

The Canada goose is the most faithful and self-sacrificing bird on earth. I kept one for

four years, and I know. I kept old Jack Johnson for two years and a half, but I got rid of him. I wouldn't keep a wild goose or a gander around the premises after he had lost his sweetheart; they just keep on honking in that sad way. But the poorest-principled piece of live flesh in feathers is the drake; he is nothing but a Brigham Young, that's all. Puts me in mind of the mother who has to be father and mother both, like some poor washwoman who goes out and does \$5 worth of work and willingly accepts 50 cents for it; then takes it home to feed her family, while the lazy, good-for-nothing husband is putting in his time in the far end of nowhere, swapping garbage stories and passing remarks about the clean people that pass the dirty window. That is the principle of the drake.

#### MONEY FROM STUMPS.

The Washington Legislature is being asked, through the Spokane Chamber of Commerce, to establish a by-product plant, to be used for the extraction of turpentine, resin, etc., from the stumps, fallen timber and such stuff lying throughout the state. It is expected that the lumbermen of Idaho will also endeavor to have such a plan adopted by their State Legislature.

#### NOVA SCOTIA'S GAIN.

That the business welfare of Nova Scotia calls for the appointment of a Provincial Forester, is a truth that has had many exponents. Mr. D. Macgillivray, President of the Halifax Board of Trade, said recently in his annual address:

"In the transition from war conditions to those of peace, Nova Scotia will have less to reconstruct, or even to readjust, than probably any other portion of Canada. This strong economic position will justify progressive policy on the part of both Government and municipalities. There is a point where caution and economy may become reactionary. The Government should match its progressive policy in agriculture by at once appointing a first class forester to make the most of our timber resources."

The tallest trees of the United States are the California redwoods or the Douglas fir. Both claim the distinction of being the tallest, and it is an even match between them. A maximum of about 350 feet is the greatest, though a little more than that has been claimed. There is no question that in trunk diameter the redwood, that species known as sequoia, is the champion.

### Table of Contents, March, 1919

|   | Page. |
|---|-------|
| Jack Miner and His Wild Fowl.....                                   | 99    |
| Civic Plan for Street Trees .....                                   | 106   |
| Facts on White Pine Menace .....                                    | 108   |
| "Trees". Poem .....   | 109   |
| Photographing Forests from the Air.....                             | 110   |
| Canada Lags in Aerial Patrols.....                                  | 113   |
| The Making of a Spruce Tree.....                                    | 114   |
| Lumbermen and the Tree Supply. By W. Gerard Power.....              | 115   |
| Wasting Prairie Province Forests.....                               | 117   |
| Does the West Need Forests?.....                                    | 118   |
| "An Eternal Source of Wealth." By Sir Hamar Greenwood.....          | 121   |
| Victoria Launches Into State Forestry. By H. R. MacMillan.....      | 124   |
| Probable Cost of Aeroplane Patrol.....                              | 126   |
| Guarding 21 Million Acres by Co-operation. By Arthur H. Graham..... | 130   |

IF YOU WANT A CHEW  
THAT WILL JUST SUIT

YOU ASK FOR

**STAG**

**CHEWING TOBACCO**

RICH AND SATISFYING.

IT IS ALSO KNOWN TO BE  
"EVER-LASTING-LY GOOD"



## Do You Require More Capital?

For ten years, Royal Securities Corporation has been associated with the development and financing of Canada's most successful pulp and paper enterprises. Among them are:

*Abitibi Power and Paper Company.  
Brompton Pulp and Paper Company.  
Mattagami Pulp and Paper Company.  
Price Bros. and Company.  
Riordon Pulp and Paper Company.  
Whalen Pulp and Paper Mills.*

Do you desire to pay off floating indebtedness; increase your plant capacity; or acquire additional properties? If so, why not let us suggest ways of financing your requirements? Our Engineering and Statistical Departments are at your disposal.

## **Royal Securities Corporation LIMITED**

164 St. James St.,  
MONTREAL

58 King St. West,  
TORONTO



Canadian Forestry Journal  
April 1919

FACULTY OF FORESTRY

MAY 12 1919

UNIVERSITY OF TORONTO

# Gillette

## Safety Razors

The Shaving Service for Every Man  
—Everywhere



### NO STROPPING NO HONING

The absolute freedom from Honing and Stropping eliminates all the haphazard elements of shaving.

A perfect edge no longer is a rare luxury but it is the daily privilege of the Gillette Safety Razor owner.



**\$5 the Set**

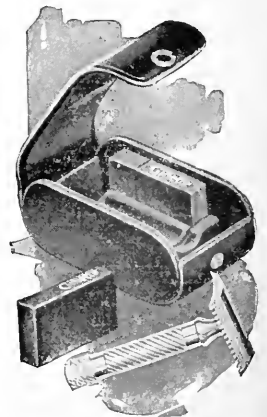

Gillette Safety Razor Co. of Canada,  
Montreal Limited



# Canadian Forestry Journal

VOL. XIV.

OTTAWA, CANADA, APRIL, 1919

No. 3



## RETURNED SOLDIERS IN FORESTRY COURSES



Five Months' Training Scheme Successfully Under Way at University of British Columbia.



At the University of British Columbia, under the charge of the Department of Soldiers' Civil Re-Establishment, is being given a five months' course in Forestry for returned Canadian soldiers, preparing them for the permanent forest ranger positions in British Columbia and Dominion Forest Branches. The present session was instituted after a short course of four weeks was tried out last spring, the successful results of the preliminary course leading to the installation of the longer period of study as being given now.

In determining upon the desirability of the course and the subjects to be given the men,

the heads of the forest branches in British Columbia and Alberta were consulted, while the results of the work given at the short courses in Forestry at the University of Washington were thoroughly looked into before decisions were made.

Instruction commenced in the buildings of the University of British Columbia on Nov. 22, 1918; the opening of the course, on schedule time, originally set for Nov. 1, being delayed by the Spanish influenza epidemic. Eleven returned men were on hand the opening day, and before the end of the first month's instruction

twenty-one were enrolled, this being the present size of the class. For the directorship of the course the Department obtained the services of E. J. Hanzlik, Esq., Forest Examiner, United States Forest Service. He is also handling the tuition in the forestry subjects. Mathematics and forest surveying are being given by A. Lighthall, Esq., a British Columbia civil engineer, who has both teaching and practical experience, while the forest botany is given by Dr. A. H. Hutchinson, of the University faculty, and J. Davidson, Esq., L.L.S., F.B.S.E., Provincial Botanist for British Columbia.

### **Field Work Emphasized.**

In presenting the various subjects their practical application to the forest ranger's work is constantly in mind, in addition to which frequent field work is a regular part of the programme. Visits to mills, log-booms for scaling practice, the near-by woods for forest mensuration and botanical work are regularly undertaken in order to acquaint the men with as near actual conditions as possible. Before the completion of the course of study it is planned to spend about two weeks upon some tract of timber where all phases of the work may be had, such as forest surveying, log scaling, timber cruising, mapping, identification of species, etc.

### **Special Lectures.**

In addition to the prescribed work given by the regular corps of instructors the services of men in the British Columbia and Dominion Forest Branches and others either in the forest or lumbering businesses, are being utilized whenever possible. Before the Christmas holidays, T. P. MacKenzie, Esq., Grazing Commissioner for British Columbia, favored the class with a comprehensive talk on the plans for utilizing to their fullest capacity the grazing lands of British Columbia, and gave an insight to the great importance of the interior forests of the province toward helping to solve the problem of utilizing the grazing ranges to their greatest capacity and for their best development. L. L. Brown, Esq., in charge of the Dominion Timber Testing Laboratory, at Vancouver, gave an instructive talk on the strength, stiffness and other qualities of British Columbia species, which was followed by a practical demonstration in testing specimens by means of the Olsen testing machine. On Feb. 13th the class had as a special lecturer the services of Ronald D. Craig, Esq., member of the Commission of Conservation, who discoursed on the Forests of British Columbia. Be-

fore the close of the course the officials of the Dominion Forestry Branch from Alberta and British Columbia, and from the British Columbia Provincial Forest Branch will give talks on such practical forest administration as pertain directly to the work in these branches.

There are enrolled for this course the following named men: J. Brackley, A. J. Braithwaite, Wm. Byers, M. Damgaard, M. S. Dick, W. Giddings, Robt. Gritten, F. Hamilton, A. J. Horne, A. Jackson, P. C. Malmo, T. Paterson, G. T. Schupe, E. J. Thomas, J. W. Weyman and G. W. Wood, all from British Columbia; and R. Everett, G. H. Fosberry, D. J. Margach, J. H. Rennie, H. M. Taylor, from Alberta.

Instruction will continue through the month of March and possibly the first two weeks in April, the last two weeks of the course being carried on in actual work in the woods.

### **THIS BALANCE REQUIRES ADJUSTING!**

Canada spends on experimental work to aid agricultural production over \$700,000 a year.

Canada spends on experimental work in the cultivation of forests about \$30,000 a year.

This deadening anomaly is a survival of the antiquated notion that forests are a way-station to agriculture, whereas enormous areas of cleared (and barren) lands are merely way-stations to forestry.

There are more acres of cleared land that must be put under forest than there are acres of forest that can ever properly be turned into farms.

Says D. E. Hutchins, the noted forester:

"Forestry is the business of the State, agriculture of the private individual. This is recognized in the schools of political economy the world through.

"Ordinarily all that the State can do for agriculture is to help the farmer with advice; sometimes with a State farm, and sometimes with seed and fertilizers, when the ordinary trade channels are not satisfactory. Too often experimental farms fail, as does also the Government teaching! But it may be fairly assumed that in a new country the Government should aid, as far as may be, the farmer and his work.

"But in forestry it is another story; the Government, for better or for worse, has to do the bulk of the work itself, hence a necessary heavy expenditure, such as 7,000,000 pounds sterling a year on forestry in Germany."

## A MACHINE TO LOCATE FOREST FIRES

The Osborne fire-finder, now in use by the Dominion Forestry Branch at Kamloops, was invented by W. B. Osborne, of the United States Forest Service at Portland, Oregon. It consists of a heavy circular metal base graduated near the outer edge. This base is supported below on four short metal legs or points which rest on two solid metal rods. The rods are screwed to a board and act as a track or guide upon which the points can slide back and forth. This sliding device is for the purpose of overcoming any nearby obstruction which may be in the line of sight, as for instance an upright or a window-frame in the lookout station itself.

Attached to the graduated circular base, and lying flat upon it, is a detachable circular disc of sheet metal. Mounted on the surface of this metal disc is the map of the country surrounding the lookout station. The map is so mounted that the position of the lookout station on the map is exactly in the centre of the disc. The whole map and disc is covered with a transparent shellac or varnish to preserve it and prevent it becoming marked or weathered.

Fitting on top of the graduate base piece is a sliding metal ring of a slightly smaller diameter than the base, and which may be turned through 360 degrees in either direction. To this sliding ring are attached two upright sighting pieces, also a handle or grip for the purpose of turning or sliding the ring. The sighting is done through a small slit, or a peep-hole, in the eye piece upon a vertical horse-hair in the object piece. A horizontal horse-hair is also stretched between the two sighting pieces. Stretched with edge up between the two uprights, and just above the map is a flexible metal tape. It is graduated into inches and fractions of inches from the middle towards the ends, and by means of it the distance from the lookout station to any point on the map may be read. Attached to the sliding ring, at the base of the upright eye piece, is a vernier for the purpose of reading the angle through which the line of sight is turned.

The instrument also includes an attachment for the sketching of a panoramic profile of the surrounding country. A paper circle is laid over the map. Then by following with the "point" the outline of the mountains and hills as they exist, their profile is automatically trans-



The fire finder at work. See accompanying article.

ferred to the paper. The thumb-screw imparts a horizontal movement to the pencil at the same time that it moves the point in a vertical one. The complete instrument weighs about fifty pounds.

### BOY SCOUTS TO PLANT.

In order to give permanent expression to "all Colonel Roosevelt stood for to the boys of the nation," 16,000 troops of the Boy Scouts of America, comprising 440,000 members, have been instructed to plant one or more trees with suitable inscription and ceremony in memory of the former President, the National Council of the organization said in a telegram of condolence sent to Mrs. Roosevelt at Oyster Bay.

### FORESTRY AT OXFORD.

(London Times.)

A statute was presented to Congregation at Oxford by Sir Herbert Warren, President of Magdalen, establishing a Professorship of Forestry, as a Chair of the first order, with an endowment of £900 per annum. He said that the subject was one both poetically and practically worthy of Oxford. If England no longer depended on her oak forests for her "wooden walls", yet the pit-prop was the support on which rested both our navy and our industrial prosperity.



How a road can be cut through a woods without destroying the trees.



A group of fir trees that well adorn a rural road. The roots have been mulched to preserve the trees pending the building of a dwarf retaining wall. In many instances trees can only be properly preserved in groups and this must be done before the land is subdivided. (From report of Thomas Adams, Town Planning Adviser of the Commission of Conservation.)

## BRITISH COLUMBIA REDUCES FIRE HAZARDS

*By M. A. Grainger, Chief Forester.*

### New Legislation Renders Obligatory the Burning of Debris in Commercial Operations—More Equipment Bought.

The system of using light cars for fire-ranging work will be substantially the same as last year; i.e., 23 cars purchased by the department and 10 hired cars were in use, making it possible for rangers to get from place to place rapidly, to investigate reported fires promptly, and to take immediate steps in fire-fighting.

There will probably be a slight increase in those in use along the coast, where travel by land is very slow and difficult on account of the dense undergrowth, lack of roads, and the number of waterways intersecting the country.

There will probably be a slight increase in personnel. This will be accounted for, by the fact that many of our men overseas will be returning; and that there is an increasing public recognition of the menace to public revenue created by unsupervised logging and land clearing which will make possible the expenditure necessary to a larger force.

#### **Burn Old Slashes.**

It is proposed to burn old slash, created by now defunct logging operations, under the supervision of the Forest Branch, in cases where this is desirable to save the cost of patrolling such hazard every year. This will eliminate a considerable fire hazard throughout the province.

The disposal of new slash is covered by the following amendment to the Forest Act now in the Committee stage:

Said chapter 17 is amended by inserting therein the following as section 127a:

"127a. (1) Where as a result of the carrying on of any operation for the cutting or removal of trees or timber slash including in that expression any brush or debris, is occasioned or accumulated subsequent to the enactment of this section, the person or corporation carrying on the operation shall, on the demand of any officer authorized by the Department, dispose of the slash by burning or otherwise to the satisfaction of the Department. In the case of lands in respect of which an annual tax is payable to the Forest Protection Fund, the expenses incurred in the work of disposing of the slash thereon under this subsection shall be borne

half by the person or corporation carrying on the operation, and half by the Forest Protection Fund.

"(2) Where any person or corporation fails or neglects to dispose of any slash at the time and in the manner required under this section, the Department may dispose of the slash, in which case all expense incurred therein shall be forthwith due and payable to the Crown from that person or corporation for the purposes of the Forest Protection Fund. The Crown shall have a lien for the amount of any expense so payable to the Crown, and for all expenses of seizure or detention incurred under this subsection upon all engines, logging plant, equipment, and material used in the operation in which the slash was occasioned or accumulated, or belonging to the person or corporation carrying on the operation, and also against the lands upon which the operation in which the slash was occasioned or accumulated was in whole or in part carried on; and such lien shall constitute a charge to the like extent, and shall confer the same rights, and shall be registrable and enforceable in the same manner as the liens created by the provisions of section 60.

"(3) Where the lands upon which the operation in which the slash was occasioned or accumulated was in whole or in part carried on are included in any special license, no renewal of that license shall be granted until all expenses due to the Crown under this section in respect of those lands are paid in full."

A number of forest fire pumps are being purchased. Last year a trial of these appliances was made and proved a great success. The thorough soaking given by the pumps minimizes the great danger commonly associated with early slash burning of leaving smouldering fires which last into the dry season and sometimes develop destructive activity.

Operators are more and more showing a desire to co-operate with the Department in this kind of work, and are greatly reducing future risks by burning slash.



Photo by Ernest G. Poole, Cochrane, Ont.

A runaway fire in Northern Ontario. A settler refused to take precautions and started a hot fire too near the standing timber. It got beyond his control and in the photograph is seen sweeping through the tangled spruce.



SOMEBODY'S CAMPFIRE DID THIS.

Miles of woodland turned into charcoal because one camper "forgot" his fire.

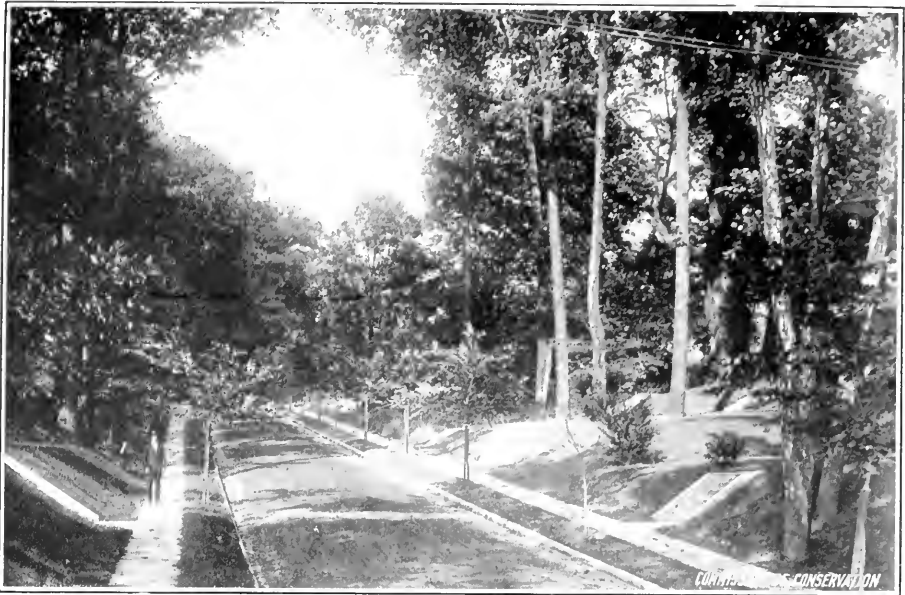

THE IDEAL OF THE TOWN PLANNER.

Narrow roads and wide spaces between lines of buildings and street lines: Why have expensive wide roads in purely residential districts?



At Charlottetown, P.E.I. On axis of Great George Street, showing effect of early planning of the city.



## “ZEPS” AND FOREST PATROLLING

*Inasmuch as the Dominion Parks Branch is investigating the possibilities of a lighter-than-air machine for fire prevention, the following article by Flight Commander Barron, a well-known Canadian aviator, will prove interesting:*

The public, I know, is less conversant with airship matters and how operations are carried out than with airplanes, and therefore it may interest you to know how now to proceed, having established our base and erected our tents—in other words, how we should inflate and rig our ships.

This is done by spreading deck cloths on the ground, on which the envelope is to lie. If this protection between the envelope and the ground were not afforded many punctures might be caused by brambles and twigs, to the fabric, which consists only of rubber and cotton, two ply on the bias, with a preparation of doped varnish on the outside to prevent permeability. This having been done, with the necessary requisites, such as the insertions of valves, etc., a large net of strong cord line is drawn over the envelope. Hydrogen is then turned in from the cylinders by means of a fabric hose, and as the envelope becomes inflated and rises from the ground, bags filled with sand (which is the most suitable form of weights) are hung on the meshes of the net at each side. The envelope is allowed to rise by shifting these bags further down the net to a sufficient height, when the car is moved to, roughly, the proper position for rigging, and this is then carried out. The planes for stabilizing and controlling are then rigged to the tail, and the net pulled by one side until it falls from the envelope.

The ship thus rigged and ready for flight would be pegged down by means of wire hawsers from certain points on the envelope to strong pegs secured in the ground.

The number of men required for airship operations of any kind anywhere is dependent upon two things:

1. Size and type of airships to be used.
2. Weather conditions.

Regarding No. 1.—It is not necessary to use a ship of large size for this particular work, as the small low altitude type gives quite a sufficient endurance for working ten hours per day and

require less man than a larger ship whose longer endurance would not be required.

Regarding No. 2.—One of the greatest drawbacks in the past, and which has not yet been entirely removed, which we have experienced with airships has been the number of men required for landing parties and handling on the ground on any occasion when the air has been disturbed by wind. The drawback is being greatly overcome by mechanical arrangements, which we could not hope to fit up on our expedition now. I should think that in all an ample number would be:

- 3 pilots
- 2 motor engineers
- 2 wireless operators
- 1 carpenter
- 3 riggers and working party
- 2 photographic ratings
- 1 cook.

Regarding the actual transportation of the ship and stores: To the average person this must seem rather a big job when considering the packing up of an airship 150 feet in length. It is not, however, as formidable as it sounds, for this sized envelope, when deflated and rolled up, occupies a case roughly only 12 feet long, 8 feet wide and 6 feet high.

Without knowing more about conditions and work to be carried out, it is somewhat difficult to say just what material and stores would be required, but a rough idea might be interesting.

Apart from the ship herself and fittings, a certain amount of gear would be needed to establish a base for carrying out the work, such as one replacement of all material used, i.e., wires for rigging and rope hawsers, one spare engine, one net for rigging, deck cloths, 200 ballast bags and hooks, one spare stabilizing plane, petrol and oil for ten hours' flying each day for a period expected to take for work, hydrogen equipment, personnel equipment, such as tents, etc., wireless and hydrogen equipment.

## FERTILIZE YOUR SHADE TREES

A well fertilized shade tree will make a much more rapid growth and present a more vigorous appearance than one which is not properly nourished. The leaves will be larger; will all come out at the same time; will show a uniformity in the characteristic color; and will remain on the tree until maturity.

A tree that lacks plant food will have a sickly appearance. When the leaves come out in the spring, they are often more or less in bunches near the ends of the branches. This indicates that the tree does not have enough vitality to develop the leaf-buds back of the terminal buds. The leaves will be fewer, and many under size. All will not have the characteristic color, and some will turn yellow early and drop. If a whole branch or the tips of some of the branches die, it is usually a sure sign that the tree is not receiving the proper amount of plant food or moisture.

However, it must not be forgotten that a tree may be "sick" from plant disease, insect pest, etc.

A starving tree grows slowly. If our so-called slow growing tree were well fertilized and mulched, the rate of growth would be a surprise. Commercial fertilizers can be used, but they are not so effective as well rotted stable manure. In lieu of manure a well rotted compost of leaves, etc., can be used. If the appearance of manure around a tree is objectionable, it can be covered with a light coat of straw or leaves. The covering can be prevented from blowing away by weighting with sticks, brush, woven wire fencing, etc. The depth of the fertilizer should be two to three inches, depending upon the requirements of the tree. It should not be placed closer than 18 inches of the tree, so that mice will not nest about the tree and bark it. It should be spread around the tree to a distance of at least a foot beyond the length of the branches. Remember that the principal feeding roots are located as far from the tree as the length of the branches or much farther.

### NEW PENTICTON CLUB FORMED.

A good stroke was accomplished at a recent meeting at Penticton, B.C., to form a Penticton Fish and Game Association. On representations

of Mr. R. S. Wilton the name was made to include the words, "and Forest Protection".

### HOW TO TAX TIMBER.

Needed reform in our method of taxing timber is a somewhat hackneyed subject, but some new light was furnished upon it in an address delivered by Orlando T. Barnes before the annual meeting recently of the Michigan Hardwood Manufacturers' Association.

It is generally recognized that a yield tax when timber is cut gives much better results from the standpoint of timber growing encouragement. It, however, greatly reduces the tax revenues of timber counties and townships and retards public improvements. The compromise has already been suggested of taxing the land annually on its value as stump land, and the value of the timber only when cut.

This speaker in addition to a thorough development of this idea suggests further that when the timber is mature it may well stand a moderate annual tax on its value if the owner desires still further to hold it.

This introduces another question which this speaker does not consider. He apparently is speaking of a body of planted timber of practically even age class, all of which would naturally arrive at maturity about the same time. In virgin forest, however, or any forest naturally reproduced under most conditions, there is a mixture of practically all age classes, so that at any given time only a part of the total stand of timber is really mature.

Inasmuch also as the determination of the boundary between timber which is still making a satisfactory annual increment of value by growth and timber in which the growth curve and the carrying cost curve have practically approximated each other requires expert forestry judgment it is obvious that the administration of a tax law of any such refinement could not be left to the judgment of such assessing bodies as we have at this time. That, however, is not to say that the ideas are not entirely practical, but that it remains to develop all the necessary details of administering them.—American Lumberman.

**ONLY A WORD.**

*By Douglas Malloch, the Lumberman Poet.*

Sometimes, afoot afar in some new wild,  
A clouded night without a star to burn,  
With all his wit, when man is but a child,  
A wanderer who knows not where to turn.

Sometime, when night encompasses about,  
Without a trail to lead my feet aright,  
When every sound I fear and step I doubt,  
My eyes have caught the glimmer of a light.

Some little beacon from a cabin small  
Has thrown its beam across the darkest wood,  
And I have found a refuge, after all,  
A waiting fire, a cup, and brotherhood.

Sometimes, upon the trail of life alone,  
Without a guide, without a star to steer,  
When all my feet encountered was the stone,  
And only flying terrors in my ear,

Then I have heard a word of kindness said,  
When in the wilderness of living lost,  
And I have followed on with lifted head  
Until the threshold of a heart I crossed.

These are the signals in the wilderness,  
The lights we burn not knowing just for whom,  
Only that pilgrims through the forest press  
And need some word of kindness in the gloom,

Only a candle when the night is dour,  
Only a kindness when the hope is dim,  
Burning the brightest in the darkest hour  
To guide the wanderer and welcome him.

**SOLDIERS AT A "SHINGLE SCHOOL".**

Most Canadians will applaud the work of the British Columbia Shingle Agency in opening a "school" for the training of white men in making and packing shingles. At present the coast mills are at the mercy of Chinese labor. Ten returned soldiers entered the "school" on the first morning and made such remarkable progress that it is expected that a month will suffice to equip them sufficiently to take a good job in any shingle mill of the province. While in training the men are paid \$3 a day for sawyers and \$2.50 a day for packers. Recently the Orientals went on strike as a protest to a cut in pay. British Columbia has 300 shingle making machines.

**"WOODLANDS" SUMMER MEETING.**

The Council of the Woodlands Section have decided to hold the summer meeting at the end of June at Berthier, taking advantage of the offer of Mr. Piche to loan the large building at the Berthier Nurseries for this purpose. A very cordial invitation comes from the Laurentide Company to visit their nurseries.

**DR. BATES RESIGNS.**

Dr. John L. Bates, superintendent of the Forest Products Laboratories, Montreal, has resigned. Dr. Bates has rendered splendid service and has materially strengthened the position of the Laboratories in the eyes of the wood-using industries and the general public. He joins the staff of Price Bros. & Co., Quebec.

**ANNUAL HAMMERFEST.**

The forestry students of University of New Brunswick and their guests assembled on Saturday evening, March 15th, at Camp Idyle-a-wyle on Woodstock road. This camp is owned by Mr. Vavasour, whose son, Kenneth, is a graduate of the U.N.B. Forest School. Among the guests were Mr. J. D. Tothill, of the Entomological Branch, Mr. G. H. Prince, Provincial Forester, and the staff of the drafting department of the Forest Survey.

**GOOD WORK FOR ALBERTA.**

"Another point which should be covered by provincial legislation is the situation with respect to some 350 miles of provincially-chartered railways in Northern Alberta. These lines are not subject to the jurisdiction of the Dominion Railway Commission, nor is there adequate provincial legislation imposing requirements relative to the prevention and control of fires due to railway agencies."—Annual Report, Commission of Conservation.

**FROM NEW BRUNSWICK.**

"We certainly owe the Forestry Association a large debt in aiding this Department in so valuable a manner with regard to our new forest programme, but outside of that the Association is doing splendid work all over the Dominion so that it should be strongly supported."—From Col. T. G. Loggie, Deputy Minister of Lands and Mines, Fredericton.



THE MOTHER TREE AND HER CHILDREN.

An interesting photograph of a white spruce tree and the result of its scattering of seed. All of the trees in the picture were the product of natural regeneration. Photo taken in Saskatchewan by B. R. Morton.



Loblolly pine on an Alberta mountain top waging a losing battle against adverse conditions. None of the trees has been able to get beyond scrub size.

# FLOODS AND EROSION—CAUSE AND CURE

*Samuel T. Dana, Assistant Chief of Forest Investigation, Washington.*

How any interference with the protective cover of trees and other vegetation works to the detriment of the water user is illustrated by the history of a small stream on the Pike Forest known as Trail Creek. This was originally a clear stream confined to a narrow channel and with comparatively little erosion. Gradually, however, the character of the stream changed as a result of heavy cutting on its watershed prior to the creation of the National Forest and on private lands included within the Forest boundaries, followed by a number of severe forest fires. Floods became more frequent, erosion set in, the stream beds were widened, and their bottoms began to fill up with sand and gravel washed down from above.

## **A Ranch Buried.**

In April, 1914, a heavy flood occurred which wrought serious damage to a small ranch at the mouth of the creek. Approximately 11 acres of irrigated land, worth \$40 an acre and including nearly a fourth of the irrigated land on the ranch, were buried under from 18 to 30 inches of coarse gravel and rendered practically worthless. Furthermore, the flood filled up the irrigating ditches so completely and changed the course of Trail Creek so markedly as to make it impossible to continue the use of water from the creek for irrigation without going to considerable expense in the construction of new improvements. In August of the next year a heavy hailstorm resulted in another flood which washed out several acres of hay land along the creek bottom and ruined 16 tons or more of hay worth \$14 a ton. The same storm also brought down an immense amount of gravel in an ordinarily dry gulch running through the farm and piled this 2½ feet deep against the kitchen door. Altogether, the floods of these two years damaged this one small ranch to the extent of at least \$600 and rendered approximately one-fourth of it practically nonproductive.

Other examples of the damage resulting from interference with the forest cover before the creation of the National Forest can be selected almost at random from the Mountain Forests of the West. In the Sangre de Cristo Range and the Greenhorn Range, in what is now the San Isabel National Forest, in southern Colorado, it is very noticeable that streams whose head-

waters have been denuded to a considerable extent of their protective cover have badly eroded channels and are subject to great extremes in flow, with frequent destructive floods, while no harmful effects of this sort are noticeable on streams whose headwaters are well timbered. Wild Cherry Creek, for example, after being almost completely burnt over, was subject to spring floods and to damage from erosion. During July it would dry up at a distance of not over 2 miles from the mouth of the canyon. As the watershed has become reforested these conditions have changed gradually until to-day the stream is not subject to floods and erosion and is more regular in its flow. During the summer it now reaches a point 4 miles below the mouth of the canyon and is used early in the fall for irrigation. Apache Creek, which formerly flowed the full length of its course all summer, since the destruction of the timber at its headwaters disappears only 2 or 3 miles from its head; and its only value for irrigation purposes after the middle of June lies in its flood waters, which are very uncertain. Hardscrabble and Medano Creeks have suffered similar results, and the list might be extended almost indefinitely.

## **Forest Cover Restored.**

On the North Fork of the Gunnison River, in western Colorado, much flood damage has occurred as a result of the extensive fires which burned over its upper watersheds in the late seventies and early eighties. Previous to that time the creek channels were narrow and rocky, beavers were abundant, and the bottom lands showed little erosion. In 1884 a heavy snowfall was followed by a flood which is estimated to have ruined at least 2,000 acres of good ranch land. Since then destructive floods have occurred every few years. In 1912 irrigated land and other property was damaged to the extent of some \$20,000, a \$5,000 bridge was washed out, and \$8,000 was expended in preventing the destruction of two other bridges. In spite of this comparatively recent damage it is generally believed that floods are becoming less frequent and less destructive as adequate fire protection on the Gunnison Forest is gradually restoring a forest cover on the burned-over areas.

# IN THE FORESTS OF CENTRAL AFRICA

By *A. S. Le Souef.*

British East Africa is an open country with little forest area or, in fact, trees of any sort; on the railway journey from Mombassa to Victoria Nyanza one travels for hundreds of miles and only sees two or three species of trees, of which the African thorn tree is common on the tableland, while the hills west of Nairobi are clothed with a large juniper, which is practically the only building wood available in any quantity, and very excellent it is, being impervious to white ant and easily worked, resembling cedar. The trees are from 50 to 100 feet high and, in favorable localities, two feet in diameter. To make up for this deficiency of timber the Forestry Department has planted large quantities of Australian trees. The only economic use made of these trees is to provide fuel for the railways and the steamers on the lake.

In Uganda one meets with quite a different class of country, for on the western shores of Victoria Nyanza starts the immense forest area that covers such a large portion of West Africa. Trees of very large size are met with in a fairly dense tropical jungle, but comparatively few are of value, and these are all hardwoods. The milling arrangements are primitive, for the trees are cut up by native labor.

The Forestry Department of Uganda is in capable hands, and a large nursery is maintained at Entebbe, where numbers of different trees, chiefly eucalyptus, are grown. These are all planted in bamboos, and were being put out round the shores of the lake—all the labor being done by women engaged on piecework—and very expert and efficient they were in handling the young trees. Several eucalyptus trees about four years old (species unknown) were about thirty feet high and very vigorous; but one long-scented gum, planted on a stony rise, and which as I should judge was twenty years old, showed signs of mal-nutrition.

The forests of Africa are more interesting than those of Australia in that they are the abode of many wild animals. Elephants are fairly numerous, and where they have been much hunted one has to be circumspect in their vicinity, as they are apt to charge. Monkeys may always be seen, while the tracks of leopards, antelope, wild pigs and many smaller animals show that the forests are well patrolled at night.

## WHERE QUININE COMES FROM.

*Dr. John Foote.*

Whenever a pessimistic physician says that drugs never cure disease, some one is sure to ask him about quinine. For quinine is one of the few antiseptics which, taken internally, will kill an invading parasite without also killing the patient. Malaria is caused by a minute parasite injected into the blood through the bite of a mosquito. The parasite usually raises a new family every other day; hence the intermittent chills and fever. Quinine, taken in proper doses and at proper intervals, will kill the parasite and cure the disease by destroying its cause. It is, therefore, a specific drug. There are few specifics.

In 1632 the Governor of Peru was much worried about his wife, the Countess of Chinchon, who was desperately ill with chills and fever. The Corregidor of Loxa recommended the bark of a certain tree which the Indians used as a medicine. The medicine was given and the Countess recovered. The bark was then rewarded for its good behavior by being called Cinchona bark. The Jesuit order afterward introduced it into Europe, where it was called Jesuits' bark.

The *Cinchona calisaya*, *Cinchona succirubra* and other species of *Chinona* are trees of various sizes, some reaching a height of 80 feet or upwards. Of the forty species, about a dozen are of economic use. They are native to New Granada, Ecuador, Peru and Bolivia and grow in dense tropical forests, in isolation or in small clumps. The work of securing the bark is of great hardship to the Indian cascadores. Having found a tree, the cascadeiro must literally hack his way to it, clean it of surrounding vines, and brush, and strip the bark from its trunk, later felling the tree and stripping the branches. The work of drying, packing and transporting this bark is done under equally adverse conditions, and the entire enterprise is difficult, dangerous and wasteful.

As early as 1854 the Dutch Government endeavored to cultivate cinchona in Java. A successful industry was established in the East Indies in 1861. Now it is cultivated in Ceylon, southern India, British Burma and many similar tropical climes.

## ACROSS TWO HEMISPHERES

The Canadian Forestry Association has members in almost every quarter of the globe. This issue of the Forestry Journal, for example, is now on its way to the following overseas points. There are, in addition, about 300 members residing in the United States:

London, Eng.  
Birmingham, Eng.  
Bristol, Eng.  
Cheltenham, Eng.  
Leeds, Eng.  
Liverpool, Eng.  
Oxford, Eng.  
Manchester, Eng.  
Norwich, Eng.  
Aberdeen, Scotland  
Edinburgh, Scotland  
Glasgow, Scotland  
Melbourne, Australia  
Pinjarra, W. Australia  
Adelaide, Australia  
Brisbane, Australia  
Sydney, Australia  
Morar, India

Naini Tai, India  
Gorakhpur, India  
Prome, Burma, India  
Dehra Dunn, India  
Calcutta, India  
Rangoon, Burmah  
Maymyo, U. Burmah  
Peermade, Travancore  
State, United Pro-  
vinces, India  
Barmula, Kashmir, India  
Kuala Lumpur, Malay  
States  
Omsk, Siberia  
Singapore, S.A.  
Kristiania, Norway  
Petrograd, Russia  
Copenhagen, Denmark  
Stockholm, Sweden

Marcia, Spain  
Georgetown, Br. Guiana  
Gers, France  
Nancy, France  
Villa Mavina, Cannes,  
France  
Cape Town, S.A.  
Moscow, Russia  
Auckland, N.Z.  
Yokohama, Japan  
Rotterdam, Holland  
Havana, Cuba  
Shanghai, China  
Bridgetown, Barbados,  
B.W.I.  
Buenos Aires, Argentine  
Republic  
Kandy, Ceylon.

### A PRESSING NEED—TREES.

The Toronto Globe.

If older Ontario were cut off from outside sources of fuel supply the people living therein would in a few years, be faced by two alternatives: a wholesale exodus or freezing to death. The statement is true. It is equally true that sufficient timber could be grown within the area named to meet all local needs in fuel without in any way limiting the acreage really fit for agricultural production. Indeed the productive capacity of good land in the old counties would be increased if waste land were covered with timber.

It is some forty years since the first Ontario forestry official was appointed. During all that time we have been intermittently discussing the forestry question. But there has been little more than talk. The time for action has now come. Protection against blasting winds, conservation of the water supply, fuel needs, all imperatively call for the adoption of a comprehensive forestry policy. Furthermore, the return of the men from overseas makes the present a peculiarly appropriate occasion for a commencement in real work.



Jack Miner, Naturalist, of Kingsville, Ont., whose remarkable exploit in attracting wild fowl to his bird sanctuary has gained him a deserved reputation.

## WINDBREAKS FOR ORCHARDS

By *W. T. Macoun, Dominion Horticulturist.*

The object of a windbreak is, as the word indicates, to break the force of the wind; and the object of breaking the force of the wind is to protect the trees from the injurious effects of exposure to the full force of it. The protection of the windbreak prevents the trees from becoming loosened or blown about by it, and thus having their growth checked. A windbreak also prevents trees from becoming unshapely as they often do when exposed to the wind. It protects the trees from cold winds which would check the development of the trees during the growing season. Windbreaks prevent fruit from being blown off the trees, and in the prairie provinces in particular they help to prevent winter killing, and the drying out of the soil by hot dry winds in summer.

At the Experimental Station at Charlottetown, P.E.I., Nappan, N.S., St. Anne de la Pocatiere, P.Q., and Cap Rouge, P.Q., it has been found necessary to plant windbreaks to protect the orchards which at all of these places are situated where they have little natural protection, and where frequently the winds are high and cold.

### On the Prairies.

Windbreaks are necessary on the prairies to lessen the drying effects of the wind both in winter and summer. It has been found that trees suffer less from winter there, where they are protected by a windbreak.

In the Provinces of Ontario and British Columbia, and in parts of the Maritime Provinces, where fruits are grown in valleys and on slopes where there is good natural protection, or where they are grown where high winds are not prevalent, windbreaks are not so necessary; and in fact in many cases it may be better to have no windbreak, as the windbreak lessens the circulation of air, and injurious insects are liable to multiply much more rapidly.

A good circulation of air is necessary, also, in combatting fungous diseases, as it is important to have leaves and fruit dry off as soon as possible after dew or rain; hence anything like a windbreak, or unpruned trees, which lessens circulation, may do more harm than good.

### Value of Spruces.

In Eastern Canada the white and red spruces make good trees for windbreaks, though the Norway spruce will in most places grow somewhat

faster, and is a good tree for this purpose. A single row of these, planted from eight to ten feet apart is quite sufficient under most conditions. The windbreak should be at least fifty feet away from the first row of fruit trees in Eastern Canada. The Norway spruce will grow, if properly cared for, at the rate of from two to three feet a year until it reaches a height of fifty or sixty feet or more. In very exposed places it is desirable to plant two rows of trees, the trees forming the second row being planted from eight to ten feet behind the trees in the first row. The first row may be composed of American Arbor-Vitae, which is rather slow growing, and the row behind made of Norway spruce or native spruce, if desired. White pine and European larch are also rapid growing trees which are useful for windbreaks in Eastern Canada. Scotch pine is inclined to be irregular in growth, and is on this account sometimes not satisfactory. Other trees, both native and exotic, will also give good satisfaction. Lombardy poplar planted about eight feet apart makes a windbreak in a short time, as it is a very fast growing tree.

### Fruit Protection.

While windbreaks are useful in Eastern Canada, they are absolutely necessary on the prairies where there is no natural protection. A windbreak on the south and west sides of an orchard or small fruit plantation to check the hot winds is of as much or greater importance on the prairie than one on the north and east sides to check the cold winds, hence it is desirable to enclose a plantation with a windbreak. Fruit trees growing close to the south or west sides of windbreaks may be more injured than benefited by the windbreak, as in late winter or early spring the sun shining on the south or west side of a windbreak raises the temperature about the fruit trees much higher than if the windbreak were not there. The fruit trees thaw out every day, frosts are severe night after night, and these extremes cause severe injury or death to the trees. Whereas, when fruit trees are on the north or east side of a windbreak, this kind of injury is not so likely to occur, and they get the protection of the other windbreak from the cold winter winds.



Some of the most useful trees for windbreaks on the prairies are the Manitoba maple or Box Elder (*Acer negundo*), the laurel-leaved willow (*Salix pentandra*), the native white spruce (*Picea canadensis*), and the Siberian pea tree (*Caragana arborescens*).

In planting trees for windbreaks on the prairies, four feet apart in the row is a good distance for all of the above except the Siberian pea tree, which should be planted about eighteen inches apart.

## RECLAIMING THE KOOTENAY FLATS

A project in which western interest is rapidly developing is the reclamation of the Kootenay flats in Creston Valley, British Columbia. These flats are eighteen miles long by five miles wide. The soil is a sandy loam of alluvial origin and is quite uniform in texture. The lower lands or marshes that are wet throughout the year contain considerably more humus than do the higher knolls and river banks. Low-lying soils usually are acid in character, but the soil of the Kootenay Valley is peculiar in that it is distinctly alkaline, and contains a large amount of lime and magnesia in carbonate form. Such land cannot become sour, but at the same time is free from alkali to any injurious extent. Analysis of the soils have been made, samples being taken from the river banks, higher meadow lands and the low meadow or marsh.

For about five weeks in June and July the lands are more or less flooded. The total area contained in the bottom lands of the Lower Kootenay is 77,204 acres of which 42,204 acres are in British Columbia. Inasmuch as the project would entail national co-operation between Idaho and British Columbia, it is indeed fortunate that the legal machinery is already in existence on both sides of the line for the formation of the drainage districts, the assessment of the lands to be benefited and the carrying out of the works.

In normal times British Columbia imports about 25 million dollars worth of agricultural produce per annum. It is proposed that by means of reclamation the Kootenay flats might easily displace a large part of this agricultural import. Once the flooding is prevented, as is already provided for in engineering plans in the hands of the Provincial Government, the tractor with the gang plow can start on the furrow. No one has ever questioned the fertility of the flooded lands. Some sections have yielded 522 bushels of potatoes to the acre. Another fortunate fact is that the area is in the heart of a populous portion of the province with large powers of consumption. Estimates place the cost of reclamation at about \$25 per acre.

## THE MONEY CROP IN NOVA SCOTIA.

Nova Scotia's Provincial Secretary reports an increase of \$101,000 in his revenues during the year ended September 30, 1918.

The Crown Lands Department also announces a net surplus for the year amounting to \$15,000. The wild land tax (imposed on limit-holders) brought \$29,000.

This splendid financial showing warms the hearts of all those now looking to the Nova Scotia Government to appoint a Provincial Forester and put its forestry house in order.

The right sort of Forester with the right sort of backing will soon provide the Provincial Government with an insurance policy on its revenues. Forest conservation, particularly in Nova Scotia, is a guarantee of permanence for coal mining, fisheries, farming, manufacturing, shipbuilding and in fact every other activity from which the people draw revenues.

## FROM A U. S. STATE FORESTER.

"The Canadian Forestry Journal is undoubtedly the best popular forestry magazine that I know of. It is most stimulating and suggestive to me in my work and I would not be without it. I wish you every success in your endeavor to improve it, which I think will be difficult, and in your very active campaign to secure better protection for Canadian forests."

## CAMP FOREMAN UP TO DATE.

James Ludgate, of Parry Sound, believes in keeping his camp foremen in line with forestry developments. Mr. Ludgate has ordered Forestry Journal subscriptions for seven of these officials.

## RED-BELT INJURY IN BRITISH COLUMBIA

By *Geo. P. Melrose, B.Sc.F., District Forester,  
Vernon Forest District.*

Early in the spring of 1916 reports were received at the Vernon District office that large areas of soft (Western Yellow) Pine and Douglas fir had been killed during the winter. The worst reports came from the Nicola and Merritt country, where some trouble had been experienced with bark-beetles, and it was feared that these new outbreaks were fresh manifestations of the beetles.

Upon examination of the areas in question it was found that they occurred in very definite horizontal streaks along the sides of the mountains. Usually the lower limits were about 1,000 feet above the main valley and the upper limits 300 to 500 feet higher. The worst damage was done on south-westerly exposures.

Trees on the more exposed parts of the mountains were affected more than those in more sheltered positions. The two species present, Soft Pine and Douglas fir shared equally in the damage.

Close examination of the trees showed the needles to be reddened and apparently dead for most of their length. The bases of the needles were usually still green except on the more exposed positions where the worst cases seemed entirely killed. No damage, apparently, was done the terminal buds. No signs of bark beetles or other insects could be found, save an odd tree here and there, as is common in all such stands, and a few isolated examples of a white fungus growth or scale insect. Neither of these could have caused the extensive damage shown.

One peculiar effect of this injury was the distinct level at which it occurred. Apparently the upper and lower edges followed an exact level as though the contours were actually drawn on the hill-side. As the bottom of the strip was reached the injury got further into the tops of the trees leaving the needles on the lower limbs unharmed. The trees just reaching the edge of the belt had the tips of the crowns just touched with red. In the same way the lower limbs of the trees on the upper edge of the belt were injured, the unharmed tops becoming longer and longer the further up the hill the trees grew.

After finding no insect or fungous damage to any extent to warrant the damage shown the supposition was that weather conditions were

responsible. The winter had been extremely long and cold for that region and spring came late.

The supposition was that a sudden change in temperature had occurred at the level indicated by the damage, probably accompanied by or caused by a "Chinook" wind. The needles suddenly commenced excessive transpiration, and the water loss thus occasioned could not be replenished from the still frozen trunks, twigs, and shoots, with the result that the needles turned brown and died.

Where the injury was particularly severe, complete defoliation occurred and the trees died, but this only happened in a few of the more exposed situations. As a rule the affected trees recovered, and are now in good vigorous condition.

A form of injury that this might lead up to would be that of bark-beetles. These insects prefer weakened or dying trees, and conditions after the red-belt injury takes place would seem to be ideal for an insect outbreak. Careful watch has been kept on the areas in question but, so far, no insect outbreaks have occurred.

The name of the injury is derived from its occurrence in belts and it has been observed in several localities throughout Southern British Columbia and the western United States. The consensus of opinion wherever it has been studied seems to be that it is not of very great economic importance. The actual damage done is not sufficient to warrant remedial measures if such were possible.

### QUEBEC FOREST FIRES.

Last year, according to the report of C. J. Hall, the superintendent of the Quebec Forest Protection Service, there were 430 forest fires in that province which devastated 23 square miles of forests. The total damage was only \$5,557. The splendid results achieved are due largely to the efficiency of the work of the private fire protective associations.

## WILL OFFSET DAMAGE FROM LIGHTED CIGARETTES

By the kindness of Sir Mortimer B. Davis, President, and Percy R. Walters, Vice-President, of the Imperial Tobacco Company of Canada, Montreal, every purchaser of Sweet Caporal Cigarettes, which have an enormous sale throughout the Dominion, will have his attention called to the need for care with lighted matches and cigarettes while in or near the forest. Last fall, at the request of the Canadian Forestry Association, the company consented to insert fire warnings in cigarette packages commencing with the spring of 1919. Purchasers of cigarettes will now find in each package the following printed legend in readable type:

"Please do not throw away a LIGHTED cigarette.

"See that it is DEAD OUT.

"Lighted tobacco and matches are especially destructive in the FORESTS.

"Living forests mean liberal employment. Dead forests employ nobody.

"Don't be responsible for a dead forest.

"This caution is printed as a contribution to THE FOREST CONSERVATION MOVEMENT."



Results of planting white pine and spruce near the Oka Monastery, Quebec. The planting was done direct from the forest over 30 years ago by the late Father Lefebvre, using the labor of Indians and children.

## TIMBER'S HORN OF PLENTY

The following protest was addressed to the Literary Digest, by Dr. E. B. Fernow, Dean of the Faculty of Forestry, University of Toronto:

"Under the above caption you are briefing in your issue of February 15, on page 24, from the "Hardwood Record," an article which is extremely mischievous in throwing cold water on the efforts of those who preach conservation of our resources. The article is mischievous by what it implies rather than what it states and is the more mischievous because it is partially true, but only very partially.

The writer in the "Record" fails to mention that to find the necessary amount of walnut for gunstocks a close hunt in fence corners and ornamental grounds was necessary, and that at the same time substitutes were assiduously sought for and used.

He fails to mention that the cut of white pine has dwindled from over eight billion feet to less than three billion, and the price for the best grades has more than quadrupled in a short time—a sure sign of the exhaustion of supplies; and we could explain why the whole white pine business has not yet gone entirely out of existence. The guessers were not so wrong after all.

But most interesting is the explanation of conditions in France, which may allow the surprise of the writer in the "Record" at finding in that country timber enough to keep the Canadian and American forestry battalions busy.

There was, of course, nothing surprising or unknown to the French regarding their timber resources, and a country which imports annually from thirty to forty million dollars' worth of lumber is not likely to be overstocked with timber. As a matter of fact, of the 23 million acres of forest in France only 25 per cent is what is called timber forest, the rest is coppice or sprout forest, good for fuel and small dimension, though

about one-half of this contains dimension timber. Now, the bulk of the timber forest is in Government hands, and the Government practices what is called a "sustained yield" management—a management based on continuous crops. That requires the existence of stands of all ages, so that each year a stand of the proper age, mature timber, say, 100 to 120 years old, comes to be cut. The cautious French, in addition, are conservative and leave 25 per cent of what they would be entitled to cut under this management as a reserve against an evil day, such as fires, insects, windfalls or perhaps war may bring. It is this reserve that has fallen under American and Canadian axes, and in addition, the older age classes below the 100 or 120 years, perhaps down to 80 or even 60 years, which can be made useful. In a special case, in which the mill run by one of our professors in the forestry battalion, he ascertained that they were anticipating the cut of 20 years; the sustained yield management is badly crippled in all French forests by these anticipated harvests and the expectation that home supplies will suffice for reconstruction purposes is probably a futile guess.

It is, however, something better than a guess because based upon a tolerably close canvass of the Department of Commerce that the visible supply of saw timber in the United States could not keep up the present cut for more than 60 to 80 years, **if present use and abuse continues**, and Canada could not lengthen the period for more than a decade.

To reduce this capital "If" is the objective of the conservationist.

While our propagandists have cried "Wolf!" some times apparently prematurely, the wolf is coming, nevertheless."

(Signed) E. B. FERNOW.

## OVERCOMING THE FRENCH SAND DUNES

The cost of "fixing" the sand dunes of France, by planting tree seed, is given by Brigadier-General J. B. White, D.S.O., Montreal, as follows:

Aggregate cost of "fixing" a hectare (2.47 acres) of dunes:

Cutting 1,400 faggots\_\_\_\_\_ 11.20 francs  
Making the faggots into panels\_\_ 11.20 "

|                                    |        |        |
|------------------------------------|--------|--------|
| Transport of faggots 1¼ miles__    | 56.00  | francs |
| Placing faggots in position_____   | 14.00  | "      |
| Supervision _____                  | 10.00  | "      |
| One-half hectolitre of pine seed__ | 10.00  | "      |
| Five kilograms of genet _____      | 2.50   | "      |
| Planting and cultivating_____      | 4.60   | "      |
| Total _____                        | 119.50 | "      |

## A FAIR DEAL FOR WESTERN FORESTS

---

"There is still one fundamental point, concerning which action by the Dominion Government is vitally necessary in the public interest. Attention has been called, in successive reports of the Committee on Forests, to the administrative anomaly which prevents the Dominion Forestry Branch, a technical organization, with a staff of trained foresters, from having any hand in the enforcement of technical cutting regulations on licensed timber berths on Dominion lands, whether inside the forest reserves or not. The licensed timber berths naturally comprise the bulk of the accessible merchantable timber on Dominion lands, and cutting operations on these berths have, from the beginning, been conducted as though the forest were regarded as a mine rather than as a crop, notwithstanding the pro-

visions of Section 58 of the Dominion Lands Act. In other words, the present interest of the operator has been the primary consideration, rather than the permanent interest of the general public, to whom the lands belong. The methods of cutting are destructive rather than constructive, and the administrative machinery of the Government, as to these lands, has been primarily directed toward securing revenue, with no adequate provision for seeing that cutting operations are conducted in a manner calculated to leave the area in a productive condition. The anomaly of this situation is complete, and should receive consideration in any proposed scheme of departmental reorganization."—The Commission of Conservation's "Committee on Forests," 1919 report.

## PLANTING UP AND—BURNING UP!

---

*(Extract from the Report of the Committee on Conservation to the Pennsylvania State Grange, Tyrone, December 11, 1918. Gifford Pinchot was a leading member of this committee.)*

---

On the State Forests the percentage of money spent for tree planting is altogether too large, under the present circumstances. For example, far more money is spent for planting than for fire protection—on many of the forests two and three times as much. To devote ten dollars an acre to replanting comparatively small areas each year, and only a cent or two to protect young forests already planted by nature is poor business, especially when it is almost sure, at least in certain places, that the ten dollars will go to furnish fuel for a fire allowed to burn wholly or mainly because of the lack of money spent for adequate protection.

Until we can be reasonably sure that plantations made at heavy expense will not be burned up, and until the trees we have already have been made reasonably safe against fire, it is not good policy to spend money on planting trees. In comparison with other and more necessary work, far too much time and money have been spent on planting already in Pennsylvania.

We recommend that the present stock of seedlings now ready for transplanting be offered to the French, Belgian, Italian and British Governments for replanting devastated areas, and

that except for occasional small nurseries required to furnish the material for instruction, to supply private individuals who will plant, to reforest cleared ground which can surely be protected from fire, or for demonstration purposes, all nursery and planting operation on Pennsylvania State Forests shall cease until such time as a complete and effective system of fire protection has been supplied.

### "STILL IN ITS INFANCY."

---

It is quite the thing to say that the lumber industry of British Columbia is still in its infancy. But, as with all oft-repeated statements, this truth is not generally and fully appreciated. It sounds pleasant, and we hope it is all right. It may, perhaps, be brought out by considering the extent to which the industry has been developed in Sweden. That country has an area of 173,000 square miles—about half that of the Province of British Columbia—yet its forest yield is three times as great as the combined cut of the states of Washington and Oregon, and one-third of that of the entire United States.—Western Lumberman.

## FRANCE, ENGLAND AND AMERICA—A PARALLEL

Col. Henry S. Graves, Chief Forester of the United States.

It happens that the area of forest land in New England is about 25,000,000 acres. This is almost the same as the forest area of France, and in many respects the character of the forest has marked points of similarity. France is producing by growth each year 50 per cent more than New England. She has for years been improving her forests and approaching a point where she can furnish most of her domestic needs. New England by progressive diminution of capital stock and failure adequately to produce forests is going in exactly the other direction, losing ground every year. Before the war France was building up her forest resources; New England has been progressively destroying hers. Before the war France was importing about 80,000,000 cubic feet of lumber. New England's imports exceed this amount. The forest and wood-using industries of France furnished employment to over 700,000 persons, and because the forests were handled in a way to keep up production by growth this employment was permanent. It was the small industries supported from local forests that furnished employment to so many people.

England before the war left herself quite independent in forest matters. Her large merchant marine made it possible to import from many competing countries. She did not have to practice forestry. During 1915 and 1916 the excess cost over previous years of importing forest materials was \$185,000,000. The next year she had to stop importing almost entirely. She then cut down her meager forests and park timber, and finally had to rely on France, which was supplying the needs of all the armies on the west front. England now plans a great programme of reforestation. She proposes to plant up over a million acres in the next 40 years, spending during the first decade over \$17,000,000. England does not intend to again be caught without home supplies.

### THE MEDICINE FOR TROUBLE.

I've been feeling pretty blue;  
Have you ever had 'em?  
Well, I guess they're nothing new,  
Bothered even Adam.  
But I found a medicine  
For my troubles, neighbor—  
I sat down and buckled in  
With my daily labor.

Try it some time when you've got  
Feelings that are dizzy;  
Buckle in, no matter what,  
Just so you are busy.  
All the devils of despair  
In the shadows lurking  
Seldom bother you with care  
If they find you working.  
—Douglas Malloch.

### ABITIBI CO. PLANS TO PLANT.

The Abitibi Power and Paper Company, Limited, intends to begin a reforestation programme this year and has asked for the co-operation of the Commission of Conservation in this work. The Commission has been co-operating with the Riordon Pulp and Paper Company and The Laurentide Company, Limited, for one and two years respectively in reforestation work, and considerable headway has been made. The initial studies have concerned the rate of reforestation of cut-over pulpwood lands under natural conditions. Investigations to date point to the fact that it will take from 50 to 100 years for spruce and balsam to grow to merchantable size on these cut-over lands, whereas lumbermen have thought that reforestation would take place in about 30 years. Another disquieting feature the investigations have disclosed is the fact that where the pulpwood species are cut down, the new growth is predominately hardwood for which, as yet, there is little market. These scientific facts are of paramount importance both to the pulp and paper industry as well as to the Governments concerned, which have always drawn large revenues from the forests.

## EXPERIMENTS IN SCIENTIFIC CUTTING

By *Hon. W. R. Brown, The Brown Corporation,*  
Berlin, N.H., and La Tuque, Quebec.



### Importance of Clearing Out Hardwoods and Balsam Fir Emphasized by Experience



I will present briefly for your consideration and discussion the general silvical systems which the Brown Company has tried in Northern New Hampshire and Maine, with the results obtained from them twenty years after.

Our first experimentation was started in the early '90's under the direction of Professor Austin Cary, one of the first professional foresters practicing in the United States. Mr. Cary had received a thorough training in his profession abroad, and came to us shortly after completing an exhaustive study of the northern spruce under the direction of Professor B. E. Fernow, Chief of the Department of Agriculture at Washington. He was given the problem of adapting foreign methods to American conditions for the purpose of conserving a supply of pulpwood for our paper mills from our New England lands, and incidently securing a closer utilization of the crop. At the same time he showed the immediate need of a better system of fire prevention and made a careful study and report on the insect and fungi enemies of the northern woods. Under his direction various systems of cutting were tried out, the principal being:

First—Selective cutting to a diameter of 15, 14, 12 and 10 inches, under different conditions and in different stands.

Second—Clean cutting of soft woods in strips and bunches in soft wood stands.

Third—Clean cutting of soft woods in soft wood stands.

Fourth—Clean cutting of soft and hard woods in mixed stands.

I will give you the present day results obtained by these four methods carried out from 25 years ago up to the present time.

The physical conditions surrounding operations in Maine and New Hampshire are quite similar to those prevailing in Canada. The species cut in the order of their abundance are spruce, fir and pine, with a little cedar, hemlock and tamrack mixed in. The wood is cut solely for business reasons, to produce lumber and pulpwood, being taken in 38 foot logs for lum-

A PROGRESSIVE MINISTER



Hon. G. H. Ferguson, Minister of Lands, Forests and Mines, Province of Ontario.

ber, and 4, 8 and 12 foot lengths for pulp. The spruce growth is comparatively larger than the spruce growth of Quebec, and stands more thickly per acre, being principally red spruce mixed with a certain amount of the white and black varieties. Fir balsam is present in quantity of about one-third of the soft woods, and hardwoods constitute about fifty per cent of the whole stand on the lands. The country is more mountainous and broken than in Canada, with a rough and rocky bottom, covered by a soil that is thin, wet and unsuited for agriculture, but not as readily subject to fire as the sandy sub-soil of much of Quebec. Hauls rarely exceed five miles to drivable streams. Present stand is equally divided between old growth and second cuttings. Cut over soils suffer little erosion,

and cover themselves quickly with a fine reproduction of both soft and hardwoods.

I will disregard Mr. Cary's struggles for close utilization and to reduce waste in cutting (by insistence on small tops, low stumps, and the cleaning up of lodged, dry trees and skids, preventing the needless breaking down of young trees in cutting large ones, and moves taken towards a disposal of waste and other forms of fire protection) as these problems have been accepted and solved to a large degree everywhere now.

### **Storms Interfered.**

His first experiment in selective cutting was made in 1896 in Seven Ponds Township, Maine, on the Kennebeco waters which flow into the Rangeley Lakes. A 15 inch diameter selective system was chosen for a solid spruce slope type of even-aged old growth timber standing on a thin rocky soil. Two winters' careful cuttings by a single camp were made, and along came a winter's storm and blew down the remaining trees so completely and in such a tangled mass that another season's cut was necessary to clean up the drying timber, at a relatively large expense. This land restocked rapidly to young spruce and fir and will cut from 3 to 4 cords to the acre to-day.

His second experiment was in the Academy Grant, New Hampshire, on the waters of the Dead Diamond, a tributary of the Androscoggin river, in a splendid stand of old growth red spruce mixed with hardwoods, which carried from 25 to 30 cords to the acre and lay in a spruce slope and flat type.

### **14-Inch Diameter Best.**

After a study of tree growth to determine at what age and size a growing tree made the largest returns, he decided to cut to a 14-inch stump diameter, and for this purpose had the axe-handles marked in order that the choppers should cut down no trees under this diameter, measured at the swell of the highest root from the ground. All told many square miles were cut for saw logs in this region, and the young growth is now about 20 years old.

During the past year the Brown Company sent their forester, Mr. Edward R. Linn, over this territory to make a survey and report the present conditions. His report finds that the fact of cutting to a diameter limit of 14 inches in those places where hardwood stand was equal to the spruce, has been to gradually turn the forest towards an ultimate hardwood stand. The cause for this was that the trees below

14 inches on the stump had already reached maturity, being from 100 to 200 years of age, and the increment borer failed to show any appreciable increased growth during the past 20 years. The openings in the cover made by cutting out the large trees were taken up by the crowns of the surrounding hardwoods and did not induce softwood reproduction underneath. These small openings came up with the young hardwoods, and in instances where large openings occurred, such as landings, yards, roads, etc., these commonly filled with young fir which crowded out the spruce. Where just one tree was removed from hard wood the change wrought consisted only in the passing of the spruce. Where six to ten trees on a quarter-acre were removed enough light was furnished to enable fir to start, and small clumps of second growth were found. Under this hardwood type, there was a very scattering reproduction of young spruce, and fir, three to six feet high, stunted trees with bushy tops, which will never make growth or lumber of value unless the hardwood is cut.

Where the cutting to a 14-inch stump diameter in this region was done in a spruce slope type, conifers making 75 per cent of the stand, the soil good and the trees sheltered in a valley, most of the trees left were standing, and the interstices between them were coming up to an abundant growth of spruce and fir, the fir predominating, being almost too crowded to be good.

In another place where the land was rocky and soil thin, and where the situation was exposed on hill tops or knolls to the sweep of the wind, a very considerable portion of the spruce left standing had been blown over, but the reproduction in the interstices of young spruce and fir was equally good. The trees left standing, however, exhibited little or no increment of growth, because the whole region originally was an even-aged stand, and too old to take on a new growth. Logging this territory again will be increasingly expensive, as there will be less timber per acre and much damage will necessarily have to be done to the young growth to salvage the trees which were originally left.

### **Cut Clean in Even-aged Stand.**

Altogether much loss will always be experienced in leaving trees under 14 inches in diameter in an even-aged old growth stand, and such land when entered should be cut clean, leaving here and there a seed tree to restock the land, and taking if possible the hardwoods at the same time if in any manner merchantable, but if the region is and will remain



## STUDYING THE GROWTH OF TREES

An interesting experimental project in forestry is under way at the Petawawa Military Reservation, near Pembroke, Ontario, under the guidance of the Dominion Forestry Branch. Mr. H. C. Wallin is directing the work, assisted by Mr. James Kay and Mr. George Clarkson.

The object of the experiment station is to study natural reproduction of white pine and red pine chiefly, and to learn the effects of "thinning" on the increment of individual trees and of the whole stand. There will be an opportunity also to study the effect of thinning on the condition and character of the soil and ground cover, and to get data for the construction of yield tables.

The accompanying picture shows the manner of marking the trees with stencilled numbers. Every tree, with complete information regarding it, is entered on a map, so that growth and other phenomena can be accurately gauged.



remote from market, girdling the hardwoods is a step that should be well considered, if the land is desired to produce the maximum amount of softwoods for the future.

Subsequently in 1906 a certain section of the same region west of McKean Falls known as a spruce flat type was cut to a 12-inch diameter limit. As the site was fairly well protected from windfall, most of the older trees left are still standing. These trees on account of their age show little or no increased growth. They have, however, reseeded the ground splendidly and there is now a mixed stand of spruce and fire coming up of 6 to 12 feet in height. The remaining stand might cut 3 to 4 cords to the acre. But it would be unwise to go in now to log the old trees on account of the increased cost of logging due to the small cordage per acre obtainable, and because it would be murdering the reproduction to cut the older trees unless extreme care was taken, and as the older trees will be subject to windfall and decay before the young trees are ripe for cutting, much loss has been sustained and a saving could have been made by cutting to a smaller diameter limit originally, as fewer trees would have served as well for reproduction.

### Windfall Takes a Big Toll.

Still another cutting was made to a 10-inch diameter limit in an uneven-aged stand in a region known as a spruce flat merging into a hardwood

type. This was done in the town of Grafton, Maine, about ten years ago. Here the soil was fairly deep and as the situation was a low flat valley between the mountains, it was thought to be safe from heavy winds. In cutting here large clumps of trees of small diameter were left intact in a group system to protect each other from the wind, and single trees up to 10 inches on the stump in other places were left standing alone for seed trees. The result was that the isolated trees were practically all blown down, and the wind each year slowly but surely took the clumps systematically, tipping them over at the edges, which compelled the company to return again and again at great cost to salvage the blowdown, and finally to rescue what remained standing. Reproduction under a 10-inch stump limit was good, coming up particularly well where all seed trees were left, the fir predominating.

Clean cutting in an even good softwood stand in a typical softwood flat with a rocky, moist soil: This was done around Lincoln Pond, in Parkertown, Maine, where all the logs and pulpwood stand were cut in in 1899 and 1902. The tree growth was not extremely large, but very abundant. All softwoods were cut clean and peeled for pulp. All that remains of the old growth are a few scattering hardwoods which are dying and a few very much stunted and suppressed spruce 3 to 4 inches in diameter and 10 to 20 feet high. Although these trees have had plenty of light for the last 15 years,

they have made no appreciable growth, a few showing 6 inch leaders this year. The majority are alive and that is all. Some of these trees are 75 to 100 years old. While these trees were evidently not capable of reseeding the area, yet the whole region is covered with a luxuriant reproduction of spruce and fir, being 40 per cent spruce and 60 per cent fir. The spruce is 8 to 10 feet high and the fir 10 to 14 feet high. Some of the trees measure 4 inches in diameter at the collar, and show justly enough this reproduction is coming up only 8 rings to the inch in diameter breast high. Curiously enough these roads were not made. These roads are still plainly visible and fairly passable. From this circumstance Mr. Linn judged that the reproduction must have been present at the time of cutting and did not seed in from the sides or come from seed trees.

### Destroy the Hardwoods.

Clean cutting of both spruce and hardwood: A clean cutting has been made in Dummer, New Hampshire, for the past six years for both soft and hardwoods. Reproduction in these instances comes up to brush interspersed with fir that is out-topping the brush. While the reproduction of softwood is not as much as is desired, it is much thicker than where the hardwoods are left standing. The resulting forest will be a mixture of hardwoods, fir and spruce, and ascendancy slowly passing from hardwoods to fir and from fir to spruce.

The present method of cutting on Brown Company lands is to follow a nine inch stump diameter rule for spruce and pine and cut the fir and other soft woods clean, and be exceedingly careful to protect and save all the young trees and sprout growth possible while getting out the mature timber. This leaves in a spruce type stand a sufficient number of vigorous young trees to restock the land, able alike to produce seed and elastic enough to bend before the gales, and if blown over not of sufficient content to make a large loss in the aggregate. Hardwoods wherever possible are taken. Spruce stands in heavy hardwoods are either cut clean or allowed to remain to such a time as a means of getting the hardwood to market can be found. All the above with frequent modifications to suit local conditions based on a preliminary survey, plotting of areas, laying out of jobs, marking trees to be left if necessary, careful supervision of cutting and frequent inspection by a trained forester.

From the above examples the Brown Company has drawn the following conclusions which may be of interest in Canada, as general principles of cutting apply over the same general region and species, although special modification is always necessary to suit climate, soil and location. In fact every piece of land from one hundred acres up, if handled in a truly scientific way, should have its special study

and its operation determined by a trained forester. Recommendations for cutting systems to be sound must clearly be based on a knowledge of what comes up after cutting, and man's interference with the natural order of things, and the years that these have been obtainable in America are all too few. What the land restocks to in Maine and New Hampshire under certain conditions is here given as a matter of record only, leaving the other interesting problems as to why it does so, such as light conditions, moisture, temperature, altitude, soils, competition and rotation of species, etc., as a study for another time and place.

### Diameter Limits.

First—The theory of diameter limit in cutting should be based on the average age of the stand, instead of on the average size of the trees. In Quebec a study of the boundaries and years of the great fires would give a reasonably close estimate of the location of even-aged stands and form a basis of a silvical cutting system applicable to each.

Second—Mature growth softwood stands are commonly best handled if cut clean, occasional seed trees being left and sacrificed for the reproduction which they may bring, and even these seed trees are not always necessary to a splendid natural reproduction of young softwoods.

Third—In even-aged mixed stands in deep soil and well protected from the wind, thinnings can be made to advantage by selective cutting, provided the hardwood is always thinned also.

Fourth—In even-aged softwood stands where the soil is deep and there is protection from wind throw, the strip or group system of cutting can be practiced successfully.

Fifth—Fir balsam should be cut practically clean in any silvical method practiced, as it often proves to be unsound and matures and dies rapidly and needs no assistance in reseeding, and if not thinned will reseed in such abundance as to check the more valuable young spruce.

Sixth—Most land originally suitable for softwood, carrying a mixed soft and hardwood growth, will restock itself quickly and abundantly if the hardwoods are cut down or thinned out. The taking of hardwood is, of course, largely dependent on nearness to market and transportation, and it is not always possible to remove it. When the region is remote and softwoods reproduction is desired the girdling of hardwoods should be seriously considered.

Seventh—Any selection or group system of cutting presupposes more or less loss from blow down and this should be carefully balanced against the opportunity to return and the cost of salvaging this every year to market. Clean cutting is therefore particularly desirable for distant and inaccessible places.

## 3,000 LUMBER MILLS MEET CUT-OUT FORESTS

*Col. Henry S. Graves, Chief Forester of the United States.*

Many people are deluding themselves with the idea that we do not need to concern ourselves with regard to forests because of large virgin supplies which still exist in the Pacific Northwest, the Inland Empire, and California. I have even heard it suggested that if we should use up or destroy all of the forests in the United States, there are very considerable quantities of wood supplies in the great river valleys of Brazil and other South American countries.

Leaders of the southern pine manufacturers state that the bulk of the original supplies of yellow pine in the South will be exhausted in ten years and that within the next five to seven

more than 3,000 manufacturing plants will go out of existence. This is an exceedingly significant statement, because it means that the centre of the lumber production of the United States will within no long time move to the Pacific Coast. While it does not mean that there will be an actual exhaustion of all the timber in the South, it does mean that the competitive influence of southern pine in many markets will be withdrawn and that there will be the increase of prices that inevitably must follow such an important economic occurrence as the shift of the centre of supply of a raw material one to three thousand miles.

### CONTRIBUTING MEMBERSHIPS CONTINUE TO INCREASE

The list of contributing members to the Canadian Forestry Association continues to increase. The following list supplements that published in the March issue of the Forestry Journal. Each member designated "Contributing", subscribes five dollars to help spread the forest conservation propaganda. We hope to publish another substantial list in the May number:

|                           |                      |                         |
|---------------------------|----------------------|-------------------------|
| Geo. P. Murphy            | D. G. McDougall      | Hugh Paton              |
| Geo. S. McClearn          | Sir Joseph Flavelle  | Silver Creek Lumber Co. |
| Miss Alice McLennan       | C. E. L. Porteous    | I. H. Weldon            |
| C. Meredith               | Angus Shaw           | W. A. Davidson          |
| T. J. Stevenson           | Hon. E. A. Smith     | Brig. Gen. J. B. White, |
| North Coast Land Co.      | Jas. S. Wallace      | D.S.O.                  |
| S. F. Duncan              | Andrew Hamilton      | F. C. Whitman           |
| Fraser Napier             | Geo. H. Stacey       | C. B. Lowndes           |
| A. Dawson                 | A. St. L. Triggs     | E. R. Wood              |
| Miramichi Lumber Co.      | C. H. Waterous       | R. B. Whiteside         |
| J. W. Smith               | Shevlin-Clarke Co.   | C. D. Massey            |
| Powell River Company      | Walter J. Williamson | Neil Watson             |
| Senator E. D. Smith       | F. J. Trapp          | Mann & Cook             |
| J. Hanbury & Co.          | Cecil Sutherland     | Price Brothers & Co.    |
| G. Boulter                | F. K. Smith          | Hon. J. Mercier         |
| C. E. Friend              | Henry K. Wicks'eed   | E. Coatsworth           |
| Sir John Stirling Maxwell | Archibald Fraser     | John S. Russell         |
| St. Lawrence Pulp &       | Osborne Scott        | Harold Kennedy          |
| Lumber Co.                | J. B. Scott          | W. L. Sjostrom          |
| Wm. Shirton Lumber Co.    | E. W. Tobin, M.P.    | R. K. Hope              |
| Napoleon Thomas           | F. H. Wilson         |                         |



*Head Office and Works*

## DIVIDEND NOTICE

The Forest Fire Fiend of Canada, Inc., announce their intention to pay their preferred and all too common dividends of 20 thousand per cent on all neglected camp fires and tossed away cigarettes during the fiscal Spring and Summer of 1919.

## Does an Ontario Municipality Own Its Street Trees?

Canadian Forestry Journal:

Is it illegal for a property owner to tap the maple trees in front of his property on the boulevard belonging to the street? I notice an editorial in a local paper stating that "there is a by-law against this practice", and "it may not be generally known that all shade trees on the street belong to the town notwithstanding who may have planted them."

AN ONTARIO BANK MANAGER.

The newspaper editorial is probably in error. In Ontario trees planted in front of a piece of property are NOT subject in any way to municipal control. The Ontario Tree Planting Act states as follows:

"Trees so planted (by municipal council, park commissioner, or otherwise) on highways, become the property of the owner of the property

adjacent to the highway and nearest the tree so planted. Such is the case also with any tree left standing on the highway."

The same Act allows any municipality to pass by-laws for the following purposes:

"To regulate the planting of trees on highways.

"To prevent the planting of any undesirable species.

"To provide for the removal of trees planted on highways contrary to law."

At the same time the Criminal Code of Canada makes it an offence to damage a tree growing on a pleasure ground, park or garden to an extent exceeding five dollars. Section 533 of the Code mentions a penalty for damaging a tree to the extent of twenty-five cents.

It would appear, therefore, that no municipal by-law that might have been passed can interfere with the ordinary rights of property owners over trees on the highway in front of their holdings. Whether a prosecution could be instituted under the Criminal Code against a man tapping trees for sap, on the ground that the tree was damaged thereby is probably aside from the point you have in mind.



MIXING BEAUTY AND BUSINESS.

The Square at Charlottetown, P.E.I., surrounded by public buildings and stores.

## COST OF PLANTING ONTARIO'S SAND LANDS

The Ontario Provincial Forest Station lies in Norfolk County, near the north shore of Lake Erie. Here the Provincial Government has acquired 1,580 acres of land, all light, sandy soil, for extensive nursery work in reforestation. The seedlings are first grown in carefully screened seed-beds, where the natural conditions of the forest as to light and sunshine are reproduced as nearly as possible. They usually remain in the seed-beds for two years and are then trans-

planted to the nursery lines. The third year they are ready for final planting. Young trees are usually set out from five to six feet apart each way. At five feet apart it takes 1,742 plants to an acre. The estimated cost of white pine transplants is \$3.50 a thousand, and the total cost of setting out an acre, 5 x 5 feet plant is \$9.00. Prior to the war Scotch pine one-year seedlings were imported from Europe, but the Forest Station is now collecting its own seed.

## CONSERVATIVE LOGGING NOT EXPENSIVE

The question is often asked as to how much more it costs to log from purchases of United States national timber because of the methods required. D. C. Birch, forest examiner, discusses this in the Journal of Forestry from studies in the California yellow pine belt. Fixed woods improvements in such timber amount to about \$1.50 a thousand feet. The Forest Service of marking reduces the amount of timber to be taken out about 20 per cent, which results in an extra woods construction cost of about 37½ cents a thousand feet. The care required in felling and logging amounts to about 1 cent

a thousand. Yarding must be more carefully done to avoid damage to standing timber, and 6 cents is allowed for this. The rules require that dead snags be disposed of, and costs show that this is about 21 cents a snag, there being an average of about three snags to the acre. This cost figures down to about 2 cents a thousand. The removal of diseased trees costs another 7 cents. The rules require piling and burning of brush, which work is often subcontracted at 17 to 25 cents a thousand. Its cost under direct labor has ranged from 11 to 26 cents, but considered a fair price in this estimate. Fire pro-

cause of increased present labor 30 cents is connective measures, including investments in spark arrestors and fire fighting equipment, cleaning up around donkey engine settings, etc., cost about 2 cents; a total of 85½ cents.

There are, however, some compensations because of the fact that the marking system holds back about one-fifth of the timber entirely of a smaller diameter limit. The saw logs taken out average larger and therefore of course of increased quality, running larger to the better

grades of product. This increase in quality amounts from 50 cents to \$1 a thousand feet, or an average of 75 cents. The cost of felling larger timber is smaller per thousand feet of product. The fire protective measures also largely pay for themselves in reduced cost of fighting fires that actually occur. This study appears to indicate that in California yellow pine the actual net additional cost of cutting and logging national forest timber is around 7½ cents.

## DECAY IN SHADE TREES—AND TREE REPAIRS

*The Forestry Journal recently received a letter of inquiry from a member whose trees had shown signs of decay without any apparent cause. Whether the soil was too poor or could have been responsible for the deadened vitality of the trees was one of the points brought up. Following is the reply sent by the courtesy of the Director of Forestry:*

The decay in your trees is due to the presence of a decay causing fungus in the wood. The condition of the soil has probably no direct connection with its presence. All wood-decay is the result of fungus growth which has developed and spread throughout the wood structure, slowly destroying it. The common shelf-like and toad-stool projections frequently found on trees and logs are the fruiting bodies of fungi and it is on the surface of these that the tiny spores are produced which are spread by the wind or other means to neighboring trees. There they gain entrance, through wounds in the bark or where a bough has been broken or sawn off, to develop and spread decay throughout their new host. The removal of infested trees will lessen the chance of its spreading, or if it is desired to save any particular tree or trees this may be done by completely cutting out all decaying portions and, where necessary, filling in cavities with Portland cement after properly treating the wounds. Repairing a tree in this manner re-

quires considerable technical skill, and, although it can be accomplished by an intelligent amateur, it is usually best left to a thoroughly competent repairer. All traces of decayed and stained wood must be thoroughly removed, otherwise the fungus will continue to develop. It is therefore advisable before securing the assistance of one of these men to assure oneself that he is thoroughly reliable and understands his work. Should you feel that you desire to undertake the work yourself, or have it done under your direction, I shall be pleased to have a set of general instructions prepared for your guidance.

With regard to the planting of pine and spruce on your property, you should have no difficulty in growing these species on the soil described. The spruce will probably do better than the pine on the heavier soils or moister portions.

## THE FORESTRY JOURNAL AS A SALESMAN

Campbell Bros., of St. John, N.B., manufacturers of "Campbell's Patent Hammer Poll Axe", recently advertised for the first time in the Canadian Forestry Journal.

Do Journal advertisements bring new business? What do Campbell Bros. think?

"From these ads we have had **splendid results**", writes the firm's superintendent under date of April 11th.

The Forestry Journal's constituency is made up of alert, progressive people, ready and financially able to make your advertising salesmanship worth while.

## FOR SALE—CHOICE TIMBER TRACTS

One or both; located on Columbia River and Tributaries north of Revelstoke, British Columbia; twice cruised by Marwick, Mitchell, Peat & Co., New York; surveyed by Christie, Hayward & Dawson, Vancouver, B.C.; near interior market; saving in freight over coast shipments two dollars thousand. Do you want high class timber property, if so write

**S. A. HOLBROOK, Bradford, Pa., "Owner."**

### TIMBER IN M. FEET

| TRACT             | CEDAR       | SPRUCE      | FIR        | PINE       | HEMLOCK                 | TOTAL       | CEDAR<br>POLES |
|-------------------|-------------|-------------|------------|------------|-------------------------|-------------|----------------|
| Downie Creek..... | 204,143,000 | 47,228,000  | 18,186,000 | 7,473,000  | 79,748,000              | 356,778,000 | 60,612         |
| 16 mile .....     | 54,002,000  | 30,687,000  | 2,433,000  | 1,758,000  | 21,012,000              | 109,892,000 | 21,625         |
| 25 mile .....     | 67,468,000  | 39,908,000  | 28,799,000 | 5,068,000  | 47,086,000              | 188,332,000 | 27,642         |
| Goldstream .....  | 33,649,000  | 16,406,000  | 478,000    | 200,000    | 7,577,000               | 58,310,000  | 8,857          |
| 50 mile .....     | 45,890,000  | 34,395,000  | 6,050,000  | 1,155,000  | 20,095,000              | 107,585,000 | 35,360         |
| Schoonmaker ..... | 2,785,000   | 10,851,000  | 1,348,000  |            | 4,108,000               | 19,090,000  | 2,116          |
| (83 miles)        | 407,936,000 | 179,475,000 | 57,294,000 | 15,654,000 | 179,629,000             | 839,988,000 | 156,212        |
|                   |             |             |            |            | Dead and down cedar.... | 25,217,000  |                |
|                   |             |             |            |            |                         | 865,205,000 |                |

### S. A. HOLBROOK (Trustee) TRACTS.

| TRACT         | CEDAR       | SPRUCE      | FIR        | PINE       | HEMLOCK    | TOTAL       | CEDAR<br>POLES |
|---------------|-------------|-------------|------------|------------|------------|-------------|----------------|
| Gaffney ..... | 57,433,000  | 35,534,000  | 15,653,000 | 3,409,000  | 10,168,000 | 122,197,000 | 84,062         |
| 22 mile ..... | 60,880,000  | 67,425,000  | 28,951,000 | 8,223,000  | 74,131,000 | 239,622,000 | 32,569         |
| (34 miles)    | 112,313,000 | 102,959,000 | 44,604,000 | 11,642,000 | 84,299,000 | 361,619,000 | 116,631        |

**FOR BIGGER  
AND BETTER CROPS**

**STEELE, BRIGGS'  
SEEDS**

**SOLD EVERYWHERE IN CANADA**  
*WRITE FOR NEW CATALOG*

**STEELE, BRIGGS SEED CO.**  
"CANADA'S GREATEST SEED HOUSE" LIMITED

**TORONTO**  
HAMILTON WINNIPEG

# THE SIGNIFICANCE OF OUR EASTERN FORESTS

*By Dr. B. E. Fernow, Dean of the Faculty of Forestry,  
University of Toronto.*

There has been a mischievous story afloat about the "unlimited" and "inexhaustible" timber supply of the Dominion of Canada, and public men who ought to have known better have repeated it. It is mischievous because it inures wasteful use and delays the rational, conservative management of the forest resources with regard to future needs. Our knowledge of probable supplies, to be sure, is for much of the forest area, still mere guess work, but it is sufficiently well based to enable us to see that an end is in sight.

The easiest way to make one realize the exhaustibility of the timber ready for the axe in Canada is to state that the present sawmill capacity of the United States would suffice to dispose of it in less than a decade, and that, according to the best information, the timber supply of the States is about four times that of the Dominion.

Since the forest resource is looked to, to play a not insignificant role in the reconstruction of the Dominion's world trade, it is indicated to analyze the situation.

The commercial timber of Canada is found in two widely separated regions: the eastern forest and that of British Columbia. In the case of the latter the merchantable stand has been estimated recently by the Commission of Conservation on the basis of an exhaustive survey at 360,000 million feet, and enough is known to place the eastern stand at considerably less.

## **The Meaning to Canada of Wood Supplies.**

It is not usually recognized that the forests stand second as a basis for our manufacturing industries, that the annual value of our forest products equals that of our wheat crop, and that our forest industries supply around 15 per cent of our foreign trade and an equal percentage of railway traffic. It is evident that the handling of such a resource is a matter of high economic importance.

The sawmill lumber cut alone for the Dominion has reached as high as 5,000 million feet annually, and for the last decade has averaged over 4,000 million feet, worth around 60 million dollars at the mill. An analysis of the figures brings out the fact that spruce, white pine and

Douglas fir make up three-fourths of the annual lumber cut of the Dominion; this comes in the sequence of their output from the forests of Ontario, British Columbia, Quebec and New Brunswick, which provinces, indeed, furnish some 90 per cent of all our lumber. Our interest accordingly in general narrows down to a consideration of the white pine forests of Ontario and Quebec, the spruce forests of Quebec and New Brunswick, and the Douglas fir forests of British Columbia.

## **Employment and Forest Production.**

Turning our attention to eastern Canada alone, we may give a few figures to indicate the place of its forests in the economic life of this section. To begin with, there are some 30,000 men of the eastern provinces who gain a livelihood in the operations between the tree and the mill. There are over 3,000 mills engaged in converting the logs into lath, lumber, shingles, staves, etc. These mills, according to 1911 census, represented a capital of over \$96,000,000, and employed over 58,000 men, whose earnings amounted to around \$18,000,000. The wood-using industries in eastern Canada number over 3,000 firms, which require, roughly, 2,000 million feet of raw material annually, and since this is very largely of domestic origin, the industries are doubly important. While these industries could exist on imported wood material, the logging and milling industries mentioned above must pass with the exhaustion of the forest.

The pulpwood industry in the east has become of growing importance of late years, due in some measure to the waning supply in the north-eastern states. The home consumption of pulpwood has risen from 480,000 cords in 1908, valued at around \$3,000,000, to 1,765,000 cords in 1916, valued at over \$13,000,000. In addition, in that year over 1,000,000 cords were exported, valued at nearly \$7,000,000. The pulpwood manufactured into pulp in home mills has been above 1,000,000 cords annually the past six years, and has exceeded the cordage exported in the raw state since 1913. Some fifty mills are concerned, and over 85 per cent of the consumption is in Ontario and Quebec.





## FOREST TELEPHONES

Make the life of the forester better worth living. They relieve him from the appalling loneliness. They help him to keep in human voice touch with foresters miles away.

In emergencies—fire—sickness—hunger—the speed with which they can summon help is marvellous.

Write for full particulars of how to install the Northern Electric Forest Telephone System. Address the Office nearest you.

*Northern Electric Company*  
LIMITED

|          |          |           |
|----------|----------|-----------|
| Montreal | Toronto  | Regina    |
| Halifax  | London   | Calgary   |
| Ottawa   | Winnipeg | Vancouver |

***Northern Electric Forest Telephones***

### The Business Man's Angle.

Enough has been said to indicate that the eastern forests are of very great economic importance, especially so when we bear in mind that these forests are very largely found on non-agricultural lands and that these lands comprise from two-thirds to three-quarters of the provincial areas. They mean the livelihood of many thousands of men, the *raison d'être* of several thousand mills and wood factories together with various subsidiary industries, to say nothing of the direct provincial revenues, which aggregate some four million dollars annually. Every business man in eastern Canada is directly interested in the maintenance of such a prosperous state of affairs, and in the question of whether this great resource is handled in the most intelligent way. Every citizen is interested with his own pocket as to whether this forest resource is going to continue in furnishing revenue or whether its exhaustion will make direct taxation a necessity. To all appearances, unless different handling of the timber is resorted to soon, such necessity will arise in not a distant time.

### LOOKING FORWARD.

The economic importance to Canada of her great forest areas is no less apparent. The value of our primary forest products exported from the country during the past year totalled some \$200,000,000. The pulp and paper industry exports products valued at some 85,000,000 annually. The importance of perpetuating a resource that assists so largely in redressing our unfavorable trade balance can scarcely be over-emphasized.

The first and most vitally necessary step toward handling our forests as crops, rather than mines, is, of course, the prevention of fires. Great progress has been made in this direction during recent years, though much still remains to be accomplished.

The next step should be the adoption and strict enforcement of improved cutting regulations in connection with all logging operations on crown lands. The situation in this respect is least satisfactory in the Province of Ontario and on Dominion licensed timber lands in the west.—The Brockville Recorder.



*Getting rid of the fire menace.*

Clean brush disposal, settlers' cutting, Porcupine Forest Reserve, Saskatchewan.

## CANADA'S WOODPILE AS AN INDUSTRIAL MAGNET

---

The attention of the Canadian Forestry Journal has been called to a new campaign, launched by certain United States paper manufacturers, to bring such influence to bear upon the Dominion Government as to "persuade" the Government of Quebec to upset the embargo on the export of Crown Lands pulpwood which was instituted in 1910 in order to compel the manufacture of raw materials into the finished product within the boundaries of Canada.

From the memorandum of the American paper men the Forestry Journal prints the following excerpts:

"The two-fold effect of the legislation in Canada in 1910, and, in the United States in 1911, has been greatly to stimulate newsprint production in Canada, to depress it in the United States and to advance the cost of what pulpwood is obtainable to a point that makes the cost of manufacture in the United States excessive.

### **Canadian Income Cut, Too.**

"The release of the pulpwood reserves owned by our manufacturers on the Crown Lands of Quebec would afford an indefinite supply of raw material at moderate cost to our paper mills, would reduce and hold stable the selling price

of newsprint and would insure the permanent price-regulating competition of our mills with the Canadian mills which are not subject to our laws or regulations.

"United States paper interests began to purchase the leases of Crown Land limits in Quebec soon after the use of pulpwood for the manufacture of newsprint became general, and up to 1910, had acquired in the aggregate leases of some 10,000 square miles, or only a little more than 5 per cent of the spruce Crown lands of the province.

"These limits of ten thousand square miles are equal to 6,400,000 acres.

"On the conservative estimate of five cords of spruce timber to the acre, these limits carry a total of 32,000,000 cords of wood.

"Figured at 4 per cent a year, which is only 26.6 cubic feet per acre, the annual forest growth on these limits would aggregate 1,280,000 cords, or, sufficient to insure an adequate supply of pulpwood for the newsprint mills in the east indefinitely.

"The stumpage fees from this quantity of would produce \$1,288,800 a year for the provincial treasury.

Peterborough Canvas Covered and Wooden Canoes are built in all sizes and for all purposes. For Pleasure, Cruising, Trapping or Freighting.

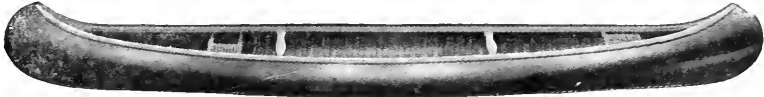

Peterborough Motor Boats, like the Canoes, are built in all sizes and for all purposes. If you are interested we will send you our illustrated Catalogue.



This Trade Mark appears on all genuine Peterborough Craft.

THE PETERBOROUGH CANOE CO. LIMITED  
Peterborough, Ontario, Canada

# FORESTERS!

We want you to know  
all about our

“ARCTIC EIDERDOWN  
SLEEPING ROBES”

It is to your own personal interest and  
comfort to own an Arctic Robe.

—Manufactured only by—

WOODS MFG. CO. LIMITED  
OTTAWA

“Booklets Ready for Mailing.”



"The cutting of the annual growth under the strict and scientific lumbering regulations of Quebec, would promote forest growth and improve, rather than impair, the forest wealth of the province.

#### Canada Profits by Embargo.

"Canada sells nearly nine-tenths of her production in this market and her sales increased 2,600 per cent from 1910 to 1918.

"In 1918 the production of newsprint in the United States was less than in 1910.

"Canadian manufacturers, virtually subsidized in respect to timber reserves and water powers, and, with lower overhead charges than their competitors in this country, have based their selling price on the higher manufacturing costs in the United States and have disappointed the expectations of those American publishers who believed that 'free Canadian paper' and 'cheap newsprint' were synonymous.

"In Canada, new developments increased

production from 161,000 tons in 1910, to 738,000 tons in 1918.

"In this case the publishers are the increased customers and their influence, unitedly and energetically exercised, will be sufficient to move Congress to negotiate with Canada, and particularly the Provincial Government of Quebec, the restoration of the property rights in the pulpwood on the Crown land limits acquired by United States interests prior to 1910.

#### U. S. Mills Fear Consequences.

"Unless these rights be restored in full, or, in modified form, as indicated by the alternative, prices are bound to attain a higher level as pulpwood becomes more scarce and its cost advances to United States manufacturers, for the price of Canadian paper will always follow that created by the manufacturing costs in this country, no matter how much lower the costs in Canada may be.

## WESTERN AUSTRALIAN PUBLIC SERVICE PERMANENT POSITIONS UNDER THE PUBLIC SERVICE ACT.

Applications will be received until May 31, 1919, for the position of Working Plans Officer in the State Forestry Department.

Salary, £504-£636.

Applicants must be qualified foresters having a degree or diploma of a forest school.

G. W. SIMPSON,  
Public Service Commissioner.

Perth, Western Australia.

## STEEL BUNKS FOR CAMPS

Included in the well-known line of DENNISTEEL factory, hospital, camp and ship equipment is the all-steel sanitary bunk illustrated. Take up very little room, are comfortable, hygienic and practically indestructible—a permanent investment. Write for particulars and folders on any of the following lines: Steel Lockers, Bins, Cabinets, Chairs, Stools, Etc. Standardized Steel Shelving (knock-down system), Steel Hospital Equipment, General Builders' Iron-work. Ornamental Bronze, Iron and Wirework. Wirework of every description.

THE DENNIS WIRE AND IRON  
WORKS CO. LIMITED

LONDON  
CANADA

HALIFAX MONTREAL OTTAWA TORONTO  
WINNIPEG VANCOUVER

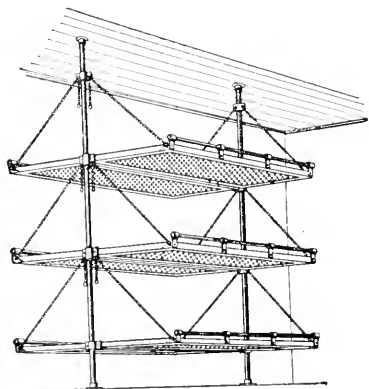

"The failure of our manufacturers to secure justice in this respect, moreover, will mean the ultimate elimination of the competition of our mills in the newsprint market and the transfer of the entire newsprint industry across the border, where corporations, existing under foreign

laws, outside the jurisdiction of our courts and not subject to the regulations of this government, may charge such prices as conditions may justify and work their own sweet will with the publishers of the United States."

## NEW LIGHT ON THE U. S. ARGUMENTS

What are our American cousins complaining of?

They draw out of Canada for their newsprint mills in American centres more than 1,000,000 cords of pulpwood a year, valued at \$7,922,000. This comes, of course, from settlers' lots and freehold lands, neither of which are subject to the embargo conditions.

Quebec Province which, according to the American Pulp and Paper Association, is so niggardly with its pulpwood as to condemn the New England newsprint mills to a slow death, sent across the United States border in 1915, 624,269 cords, valued at over \$4,000,000; 786,872 cords, in 1916, valued at over \$5,000,000; 608,830 cords, in 1917, valued at over \$5,600,000.

Ontario in the same years sent to Uncle Sam from 150,000 to 200,000 cords of raw wood for his newsprint mills annually. New Brunswick in 1917 sent 156,000 cords.

### What the United States Already Gets.

But that is not all.

The United States newsprint mills are fed not only with Canadian logs, but with mechanical and chemical pulp, the half-way station between wood and the finished paper.

Canada supplied Uncle Sam in 1918 (fiscal year) with 269,250 tons of chemical pulp and 215,584 tons of mechanical pulp, having an aggregate value of \$25,620,842.

That is, Uncle Sam received from the Dominion last year more than 1,000,000 cords of pulpwood and 484,834 tons of chemical and mechanical pulp, with a total value of over \$33,500,000.

Another point, not mentioned in the American memorandum, is that the Quebec Government in its embargo restrictions is not in any sense confiscating the earlier American investments. Any of the areas purchased before or since 1910 can be sold to-day at a profit. American companies are not fairly representing the situation when they insinuate that investments made on good faith prior to 1910 have been depreciated in market value by the embargo order.

In all probability, the 32,000,000 cords, claimed by the American newsprint mills, as the contents of their Quebec limits, can be marketed as standing timber to Canadian companies or speculators at a handsome premium over cost.

### Canadians are Agreed.

Canadian opinion appears to be well agreed that in order to prolong the life of American mills merely a few years at best, the limited Canadian supply of spruce should not be reduced by doubling the present export of logs over the border. President Dodge, of the International Paper Company, says: "With the exception of two companies, there is not a stand of spruce east of the Rockies (in the United States) that would justify the erection of a 50-ton mill". How can he expect Canadian Governments, on the look-out for new avenues of Canadian employment, to toss away a splendid national advantage just at the moment when it promises to yield maximum results? Every cord of wood sent to Uncle Sam from Canada would quadruple in value if fully manufactured on the Canadian side.

### TIMBER ORDERS PLUS—

It is highly satisfactory to learn that Great Britain is looking to Canada for the immediate supply of vast quantities of timber, says the Winnipeg Tribune. This we may well believe, is only the forerunner of vast drafts upon the virgin and almost unlimited general resources of our newer land. But the warning comes to us, in the commercial devastation of our forests, that there must go hand in hand with timber cutting, a timber replenishing policy. For the results of thoughtlessness in timber harvesting, we have only to look at the vast areas in other lands now barren and waste, veritable deserts, because there was an absence of any replenishment policy. To sell billions of feet of our timber, without an accompanying policy of reforestation, might prove, in the long run, to be a disaster rather than a blessing.

**TREES, SHRUBS and SEEDS**

HARDY NORTHERN TREE STOCK

**EDYE-DE-HURST & SON, DENNYHURST**

DRYDEN, ONT.

Shippers to H.M. Government.

**GAGNON & MORISSETTE**

TIMBERLAND CRUISERS  
LUMBER CONTRACTORS  
FOREST INDUSTRIES

CHICOUTIMI, - - P.Q.

**Hill's Seedlings & Transplants**

ALSO Tree Seeds for Reforesting. Best for over half a century. Immense stock of leading hardy sorts at low prices. Write for price list and mention this magazine. Forest Planters Guide Free.

**The D. HILL NURSERY CO.** Evergreen Specialists  
Largest Growers in America.  
Box 503. DUNDEE, Ill., U.S.A.

**LT.-COL. L. J. D. MARQUIS**

Forest Engineer and Mem. Can. Soc. of F.E.;  
Quebec Assoc. of F.E.; Former  
Mem. Que. F. Service  
Timber Factors and Logging Costs  
Facts on Forest Growth and Future Products  
Forest Cruising and Mapping  
90 LOCKWELL AVENUE - - QUEBEC

**Try This Stump Puller at Our Risk**

The Smith Stump Puller will take out every tree and stump by the roots, clearing from one to three acres a day, doing the work of twenty men. We want you to send for our 3 year guarantee against breakage and our free trial proposition. Address: **W. Smith Grubber Co.** 11 Smith St. LaCrescent, Minn.



**Timber Lands Bought & Sold**

Timber and Pulp Wood Estimates.  
**R. R. BRADLEY**  
CONSULTING FORESTER  
Globe-Atlantic Bldg. - ST. JOHN. N.B.

ASK FOR



**Timber Estimating & Mapping**

Management of Forest Properties.  
Supervision of Lumbering Operations.  
Forest Planting.  
**COOLIDGE & CARLISLE**  
FOREST ENGINEERS  
BANGOR - - - - MAINE.

**Timber Estimates**

JAMES W. SEWALL

Old Town, Maine.

## Tree-Planting for Soldier Memorials.

Several Ontario municipalities have already commenced planting trees on highways and in parks as memorials to those who enlisted for the Great War.

In order to assist this work, the Canadian Forestry Association is distributing a brochure, especially prepared by Mr. B. R. Morton, B.ScF., of the Dominion Forestry Branch, who has had wide experience in tree nursery work and tree planting. Complete directions are given for the selection of trees, whether from a nursery or a wood lot.

It is highly advisable that, in view of the risks of directly transferring trees from the dense woods to an open highway, members of the Canadian Forestry Association should write in at once for copies of the brochure and endeavor to guide intelligently the efforts of tree planting committees.

### THE HOHENZOLLERN SAWYER.

The former Kaiser William of Germany recently completed sawing into logs his thousandth tree since he took refuge at Count von Bentinck's Castle, near Amerongen, Holland, according to a news despatch dated March 17th. From the thousandth tree souvenirs of the achievement were cut and presented to admiring members of the Bentinck family, and to others who had assisted the ex-emperor in his work. Expert sawyers of the neighborhood compute the value of the wages Herr Hohenzollern would have earned, if he had been paid the union rate, at about \$23.00 for the whole period of ten weeks during which he used the saw for three hours daily.

### CANADA'S LUMBER INDUSTRY.

A census of the lumber industry in Canada has just been completed by the Dominion Bureau of Statistics, embracing 8,879 operating concerns of which 52 were in Alberta, 251 in British Columbia, 29 in Manitoba, 255 in New Brunswick, 462 in Nova Scotia, 603 in Ontario, 60 in Prince Edward Island, 1,151 in Quebec, and 16 in Saskatchewan.

The total capital invested in the industry, including land, buildings, and plant, machinery and tools, stocks in process and supplies, and working capital is given at \$149,266,019.

The number of employees on salaries was



### SPORTSMEN, PROSPECTORS, SURVEYORS

YOU want a canoe that will stand any strain—easy to handle—light on the portage, yet can carry big loads. Over the rapids is where you test a canoe.

#### CHESTNUT CANOES

are built for strength and beauty. They are finely shaped, built of the best and strongest New Brunswick Cedar and covered with a seamless, absolutely waterproof and non-destructible canvas.

The Chestnut Pleasure, Sponson, and Cruiser Canoes are comfortable, roomy, clean, safe and handsomely finished. They are the most suitable craft for the purposes for which they are designed.

**Chestnut Canoe Co. Limited**  
Box 460. FREDERICTON, N.B.

2,874 males and 285 females, who received a total of \$3,554,092. The average number of employees on wages was 25,516 engaged in logging operations and 28,820 in the mills, and their combined wages amounted to \$34,412,411.

The aggregate value of production in 1917 was \$115,777,130.

The principal kinds of lumber by species of wood used were: Spruce, 1,466,558 m. feet, white pine 79,609 m. feet, Douglas fir 706,996 m. feet, hemlock 322,722 m. feet, cedar 149,999 m. feet, red pine 119,321 m. feet, balsam fir 102,373 m. feet, and all other varieties, including custom sawn lumber, 483,133 m. feet.

The total quantities and values of lumber, lath, shingles and pulpwood cut, and of miscellaneous products, were as follows:

|                     |           |              |
|---------------------|-----------|--------------|
| Lumber              | 4,412,711 | \$83,547,322 |
| Lath                | 615,090   | 1,828,018    |
| Shingles            | 3,024,452 | 8,431,215    |
| Pulpwood            | 988,444   | 10,543,630   |
| Miscellaneous value |           | 11,426,945   |

# THE MAKING OF A SPRUCE TREE

---

ARTICLE No. 3.

---

*By Dr. C. D. Howe, Faculty of Forestry, University of Toronto.*

---

The white spruce in the St. Maurice Valley, Quebec, produced an enormous crop of seed in 1917. The cones were so abundant near the top of the trees that they hid the foliage from view and at a distance the trees seemed to be wearing light brown hoods. In some cases the branches were broken down by the weight of the cones. In the fall of 1918, however, one could hardly find a white spruce cone containing seed in the St. Maurice Valley. It may be three, five, or seven years—probably the latter, before the white spruce again seeds heavily in that district. The same holds for the other spruces and for most of our evergreen cone-bearing trees; big seed years come at intervals and between times they seed only scatteringly as a rule. It may be mentioned, parenthetically, that the long interval between seed-bearing has a very important influence upon forest nursery practice and tree planting. Owing to thoughtless newspaper agitation the public may be misled into believing that large forest planting schemes can be carried into effect upon short notice. On the contrary, seed is plentiful and cheap only in years of heavy fruiting; a year or two after it is usually scarce and expensive, and often unattainable at any price. That is practically the situation this year with regard to both pine and spruce seed. It will be two years at the earliest and it may be four or six years before another heavy seeding of these species occurs.

### **Fruiting Intervals.**

One explanation of the cause of fruiting at intervals is that seed production requires large quantities of stored food and usually it requires several years to accumulate a sufficient supply. Just before seeding all the storage places in a tree are filled to overflowing and after seeding they are drained. It takes several seasons for a tree to fill in storehouses to capacity and since seed production requires large quantities of reserved food supply, productive years are separated by non-productive years. The production of offspring draws upon the reserves of a tree as it does upon the reserves of any other mother,

hence there follows an interval of recuperation and after that an interval of accumulation of food material. The length of the interval may depend upon the weather during the growing season. If two seasons favorable for the accumulation of reserve food follow one another, then the seed years may be three years apart. If, however, seasons unfavorable for food accumulation, such as abnormally dry, cold or cloudy seasons, then it may be five or seven years before the tree can acquire sufficient reserved food to produce a seed crop.

### **Years of Heavy Yield.**

The years of strikingly abundant seed production usually occur at the longer intervals and the phenomenon extends over wide areas. For example, the heavy seeding of white spruce in 1917 apparently covered the provinces of Quebec and New Brunswick and probably the whole range of the species in Eastern Canada. The medium-sized seed crops usually occur at the shorter intervals and the interesting thing about it is that these secondary waves of production are often localized in their distribution. For example, the medium-sized seed crop of white pine in the St. Maurice, the Rouge, the Gatineau valleys might occur in three different years. Thus, if seed production depends upon weather conditions as suggested in the paragraph above, the trees must be sensitive and responsive to local variations in climate in order to fruit in different years in adjacent valleys. Still more locally, on a square mile of forest one might find a few trees in favorable positions every year bearing a crop of seeds. Thus, it would appear that some trees are more sensitive than others to the seed producing influences or else that such influences are very irregular in their distribution, both in time and space.

The growing realization of the importance of securing good reproduction of spruce and pine in our forests will doubtless lead to an investigation of peculiarities of seed production.

*(To be continued)*

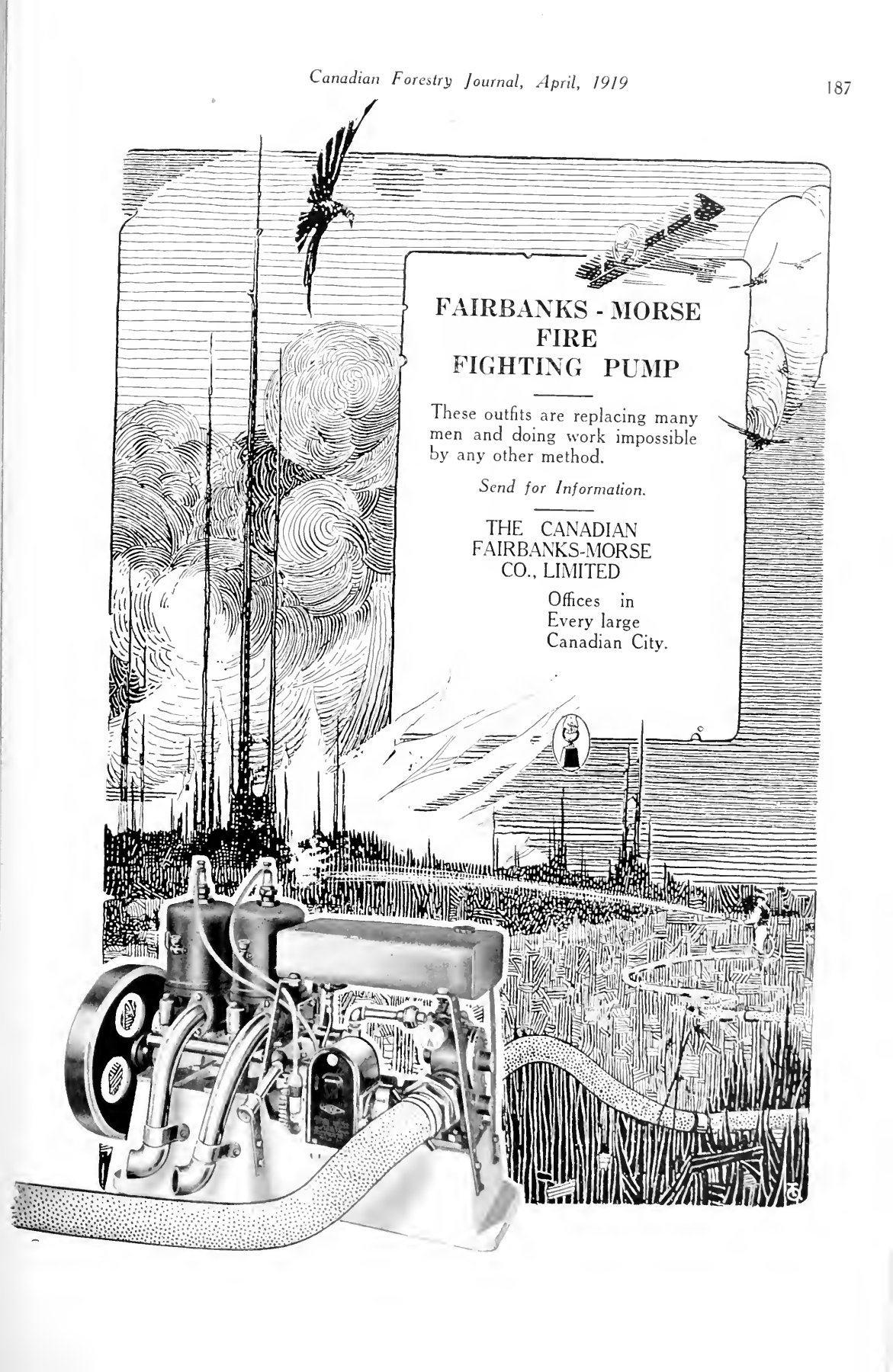

A detailed woodcut-style illustration of a forest fire. In the foreground, a Fairbanks-Morse fire pump is shown in profile, with a hose extending from it. The pump has a large flywheel on the left and various mechanical components. A hose runs across the ground, leading towards a large fire in the background. The fire is depicted with swirling, textured lines representing flames and smoke. In the distance, a large tent or structure is visible, and a person is seen near it. The sky is filled with stylized clouds and a bird is flying in the upper left. The overall scene is framed by a simple border.

## FAIRBANKS - MORSE FIRE FIGHTING PUMP

These outfits are replacing many men and doing work impossible by any other method.

*Send for Information.*

THE CANADIAN  
FAIRBANKS-MORSE  
CO., LIMITED

Offices in  
Every large  
Canadian City.

**CONFEDERATION LIFE  
ASSOCIATION**

**UNCONDITIONAL  
ACCUMULATION  
POLICIES**

Are liberal up-to-date contracts which guarantee to the insured every benefit consistent with safety.

**WRITE FOR PARTICULARS**

which will gladly be furnished by any representative of the company or the

**HEAD OFFICE,  
TORONTO**



**QUEEN'S  
UNIVERSITY**

KINGSTON  
ONTARIO

**ARTS MEDICINE  
EDUCATION  
APPLIED SCIENCE**

Mining, Chemical, Civil, Mechanical and  
Electrical Engineering.

**HOME STUDY**

Arts Course by correspondence. Degree with  
one year's attendance.

**SUMMER SCHOOL**

JULY AND AUGUST

**NAVIGATION SCHOOL**

DECEMBER TO APRIL

GEO. Y. CHOWN, *Registrar.*

**R. O. SWEZEY**

(B.Sc., M.E.I.C.)

**WATER POWERS.   TIMBER LANDS.**

**FINANCING**

**164 St. James Street - MONTREAL.**

**UNIVERSITY OF  
NEW BRUNSWICK**

FREDERICTON, N.B.

**DEPARTMENT OF FORESTRY**

Established in 1908.

Best of facilities for definite instruction and supervision in Practical Forestry.

Surveying, cruising and construction work carried on in our own tract of 3600 acres, with Forestry Camp in the centre.

Competent men from the School at present in demand to take up Forest Survey work with the Provincial Crown Land Department.

For further information address:

**DEPARTMENT OF FORESTRY**

University Calendar furnished on application.

C. C. JONES, *Chancellor.*

**P. L. BUTTRICK**

CONSULTING FORESTER

**NEW HAVEN, CONN., U. S. A.**

P.O. BOX 607

---

**TIMBER ESTIMATES  
UTILIZATION STUDIES  
PLANTING PLANS**

---

**Landscape and General Forestry Work.**  
Eight years experience in practical forestry work of all sorts.

## HOW TO CONTROL FIRES STARTED BY SETTLERS

The following statement by Hon. Jules Allard, Minister of Lands and Forests of Quebec, relative to Quebec's great success in securing the co-operation of settlers in protecting the forest is commended to our Alberta members who have been doing invaluable service in impressing upon the Alberta Government the need of a similar law to control forest fires in the timbered districts. Alberta is now the only Canadian province lacking such a law and must be content to assume all risks attendant thereto: "This forest fire law obliging settlers to take out burning permits, misunderstood at first, is now considered, even by the settlers themselves as a beneficent law and in the majority of cases settlers, I am pleased to say, readily submit to it, realizing that it is in their interest as well as in the interest of the license to protect the forest where they find employment during the winter and which is really a protection for their lands, while at the same time it assures all the parishes law constitutes, I do believe, one of the best a supply of wood goods. The application of this means of impressing on the settlers the importance of being careful when burning their slash. To show how readily the settlers comply with this law, it would suffice to say that in the territory under the supervision of the Southern St. Lawrence Forest Protective Association (Western section), 2,143 settlers asked for permits in 1918 as compared with 700 in 1917. Those who provide themselves with these permits—it goes without saying—pay more attention when burning their slash than those who do not take

out permits. As an instance—in a given territory, 4 per cent only of the former as against 25 per cent of the latter—were responsible for fires having caused damage to the neighboring property."

### Cutting Down the Causes.

According to Mr. T. W. Dwight's excellent review of forest fires in Canada and their causes, the years 1914 and 1915 in Quebec showed that 40 per cent of the fires were caused by settlers, and in 1916 this percentage fell to 6 per cent. This was due to the inauguration of a settlers' burning permit law in 1916, and to the efficient administration of it by the two forest protective associations. In the district of the earlier established association not a single fire was caused by settlers in 1916. The co-operation of the settlers was sought, and at the end of the season the relations between them and the associations were better than before the permit law went into effect.

A similar reduction in the percentage of fires due to lumbering may be noted. The greater proportion of these were caused in the past by river-drivers. In 1916, in the St. Maurice valley, the companies forming the association did not allow the river-drivers to build smudges or to smoke outside of camp, and in that valley not a single fire was caused by them.

### Ontario's Good Work.

9,590 permits were issued, principally for settlers' clearing fires—an increase of 17.5 per cent over 1917. There were five prosecutions and five convictions for burning without permit.

## THE MIRACLE OF A COMMON LOG

Undoubtedly the common log is one of the mainsprings of civilization. The European war, however, has demonstrated in a unique way the complete dependence of the military power of the Allies on the versatility of the tree.

Who that watches an aeroplane in flight realizes that the varnishes, the "dope" that covers the wings, comes from methyl alcohol, a product of distilled hardwood? Who that has noted the merciful administration of chloroform in the trenches gives a block of hardwood credit for the anaesthetic? So with creosote oils as antiseptics, charcoal for heating in the dugouts and trenches and supplying absorbents in gas masks, acetone as a solvent in cordite manufacture, pine tar, oil and pitch in shipbuilding—

these and a hundred other essentials began with distilling hardwood logs. No pair of soldier's shoes, nor saddle nor harness was turned out without oak or hemlock bark for tanning. The waste sulphite liquor of pulp mills gives toluol for the famous T.N.T. From the same source comes ethyl alcohol for explosives. No pair of optical lenses was cemented together without calling in Canada balsam.

In the direct application of the tree we find a war contribution quite as notable: railway ties, pit props to hold up dugouts, lumber for trench revetments, structural timber in building cantonments, boxes and crates for shipping shells and supplies, spruce, pine and birch for airplanes, excelsior for packing and mattress filling; "wood, wool" for wound dressings.—R.B.

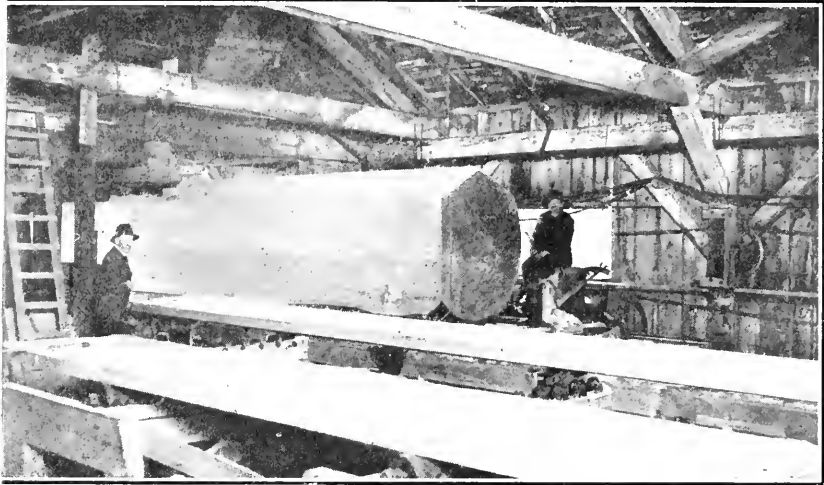

A mammoth spruce log at a Pacific Coast mill.

## TABLE OF CONTENTS FOR APRIL, 1919

|  |     |
|--|-----|
| Returned Soldiers in Forestry Courses.....     | 147 |
| A Machine to Locate Forest Fires.....          | 149 |
| British Columbia Reduces Fire Hazards.....     | 152 |
| "Zeps" and Forest Patrolling.....              | 155 |
| Fertilize Your Shade Trees.....                | 156 |
| Floods and Erosion—Cause and Cure.....         | 159 |
| In the Forests of Central Africa.....          | 160 |
| Windbreaks for Orchards.....                   | 162 |
| Reclaiming the Kootenay Flats.....             | 163 |
| Red Belt Injury in British Columbia.....       | 164 |
| Experiments in Scientific Cutting.....         | 169 |
| Significance of our Eastern Forests.....       | 178 |
| Canada's Woodpile as an Industrial Magnet..... | 180 |

IF YOU WANT A CHEW  
THAT WILL JUST SUIT

YOU ASK FOR

**STAG**

**CHEWING TOBACCO**

RICH AND SATISFYING.

IT IS ALSO KNOWN TO BE  
"EVER-LASTING-LY GOOD"



## Do You Require More Capital?

For ten years, Royal Securities Corporation has been associated with the development and financing of Canada's most successful pulp and paper enterprises. Among them are:

*Abitibi Power and Paper Company.  
Brompton Pulp and Paper Company.  
Mattagami Pulp and Paper Company.  
Price Bros. and Company.  
Riordon Pulp and Paper Company.  
Fraser Companies, Limited.*

Do you desire to pay off floating indebtedness; increase your plant capacity; or acquire additional properties? If so, why not let us suggest ways of financing your requirements? Our Engineering and Statistical Departments are at your disposal.

## **Royal Securities Corporation L i m i t e d**

164 St. James St.,  
MONTREAL

58 King St. West,  
TORONTO



# Canadian Forestry Journal

May 1919

FACULTY OF FORESTRY

JUN 1 1919

UNIVERSITY OF TORONTO

Some P.C. trees, each capable of constructing three five roomed houses.

# Gillette

## Safety Razors

THE SHAVING SERVICE FOR EVERY MAN  
—EVERYWHERE

### THE POCKET EDITION GILLETTE Bound in Seal-Grain Leather

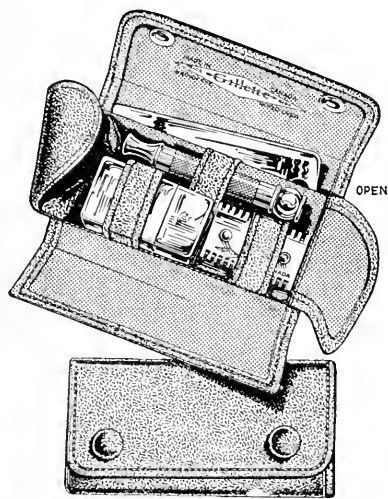

NEW KIT SET No. 20.

“If I was buying another Gillette Safety Razor”, said one enthusiast, when he saw the new Kit Set, pictured here, “I would certainly want that one.”

“It not only preserves all the good points of my old morning friend, but is as compact as any razor set I have ever seen, and takes the least room in the travelling bag:

“And then the black, seal-grain case is so dignified—so appealing to any man who is particular in his appointments: I suppose you are asking a pretty price for that set”

No; mere-----**\$5 the Set**

THE GILLETTE SAFETY RAZOR CO. OF CANADA LIMITED

LOOK FOR THE  TRADE MARK.



# Canadian Forestry Journal

VOL. XIV.

OTTAWA, CANADA, MAY, 1919

No. 4.

## TREES ARE THE BEST MEMORIALS



Living Remembrances of the Country's Defenders That Will Give Each Man an Enduring Monument



Trees are the best memorials.

In what more fitting form can the respectful sentiment of the living be enshrined?

The newspapers are surcharged with bright new ideas for the raising of monuments to the soldiers who have fought their last fight and paid the forfeit, and to those who having served valorously have returned to civil life. Nearly always the ideas are boxed in concrete, stone, brick and asbestos—a memorial hall, a bridge, a statute, a hospital.

“He who plants a tree,  
He plants love,  
Tents of coolness spreading out above  
Wayfarers he may not live to see.  
Gifts that grow are best;  
Hands that bless are blest.  
Plant! Life does the rest.”

Let us popularize a form of memorial that identifies the individual soldier with an individual living monuments. One thousand names may be hidden on a brass tablet within a public hall. There is no reason why this mass remembrance may not be given more distinction and made much more suggestive through a living ever-renewing symbol. Trees will perform this happy function perhaps better than any other medium yet suggested. Let our monuments to the country's defenders represent our personal participation in the act of tree planting rather than a charitable toss of a dollar bill into a collector's hat.

### Woodstock's Plan.

Southern Ontario already has moved in this matter. Much activity is to be found in parts of the United States where Boy Scouts and other organizations have been promoting the planting of highways in memory of Theodore Roosevelt. Motor clubs have taken up cudgels for

the planting cause and expeditions have been carried out with success. A fine example was recently set by the Woodstock (Ontario) Horticultural Society, which has adopted a plan for setting out a shade tree along a popular highway for every soldier who enlisted from the county. The trees will be given permanent identification plates.

The Canadian Forestry Association has been encouraging this work for months past and has supplied to many applicants information that tends to make planting work successful. Readers of the Forestry Journal probably are aware of the discouragements that often attend tree planting by amateurs, but the observance of a few simple rules will make the work simple and pleasurable. There is every need that before societies, schools, etc., commence a tree planting enterprise they should avail themselves of expert guidance. Particularly is this true where the tree stock is taken from woodlots and where evergreens are being handled. Unless the latter are cared for in ways that do not usually suggest themselves to the amateur, failure is almost sure to result. The Canadian Forestry Association desires to place its facilities at the disposal of all Canadians who are interested in tree planting and will be glad to co-operate with bodies of citizens planning a programme for the fall months. At this season, it is improbable that many will care to take the risks of transplanting trees in full leaf to new locations. But a busy season should open in the fall. Meantime the Forestry Journal will contain special articles for tree planters that should be kept handy. The following by Mr. F. W. H. Jacombe, of the Dominion Forestry Branch should help many to steer clear of common errors.

## HOW TO PLANT MEMORIAL TREES



### Scores of Societies Will Establish Shaded Avenues and Roadways in Remembrance of Heroic Soldiers



The first essential in planting a shade tree is to prepare a good large hole for it. If it seems needlessly large, all the better. In that case there will be plenty of loose soil around the roots, through which the little rootlets will be the better enabled to feel their way in their search for the soil-moisture. One American city, where the shade trees are under a special commission, always makes holes four feet square and three and a half feet deep. These are left for a time and gradually filled up with loose soil, fertilized if necessary; and, when the time comes that the tree is to be planted, a hole is scooped in the loose earth, a little larger than the mass of tree roots, and the tree is planted in this hole.

#### Care of the Soil.

At the least the hole should be large enough to accommodate the roots of the tree without crowding. The fine top soil first taken out should be put aside by itself, and the coarser soil taken from lower down should be similarly put aside. The tree should be put in the hole in such a way that it will stand a couple of inches deeper than it stood in the nursery. Then, first of all, the fine top soil should be put back in the hole and tramped around the roots, after which the coarser soil may be thrown in. All soil must be firmly packed around the roots, except the two or three inches at the surface, which should be left loose, in order to lessen evaporation from the soil. Any gravel there may be had better be removed altogether. If the soil is poor, it may be fertilized with artificial fertilizer or well rotted manure, but care should be taken that none of the latter is allowed to be in direct contact with the roots.

The reason for putting the top soil in first is that it contains more plant food in available form than does the deeper soil, and so gives the better chance for the rootlets to absorb it and incorporate it in the tree. The tree is put down in the hole a little deeper than it stood in the nursery because it will thus get a chance to root more quickly, the roots will be kept cool and, further, it will be able the better to resist the wind.

#### Why Prune the Tops?

At the time of planting the tree needs to be headed back, that is, to have part of its top removed. In order to understand the reason for this, it must be taken into account that while the young tree has been growing in the nursery, its root system and its system of leaves and branches have been so developed that a balance exists between them, the roots supplying just the quantity that the leaves need for their use. In the process of digging up the tree a certain proportion of the root-system has to be sacrificed; to balance this, a portion of the upper part of the tree has to be removed, or else the tree will suffer.

#### Choose Small Trees.

If you are at liberty to select the trees for yourself, do not think that the larger trees are necessarily the best. Smaller trees are easier to transplant, and in the course of a few years will overtake the trees that at the time of planting were considerably larger.

The tree should be planted while in a dormant condition, that is, in the case of a broad-leaved tree, before it leaves out in the spring or after it has shed its leaves in the autumn. Evergreens, or conifers, may be planted later in the spring or earlier in the fall. With the latter, special care must be taken that the roots do not dry out, even for an instant.

Trees planted on the street or as an avenue should not be placed nearer together than forty to fifty feet. If planted much nearer than this, both roots and branches will interfere with those of the neighboring trees, to their mutual detriment.

#### Use Nursery Stock.

Trees grown in a nursery will in all probability give more satisfaction than those taken from a woodlot. If, however, for any reason it is desired to make use of the latter, much care should be taken in the selection of the trees. They should be selected either from the outside border of the woodlot or from some well-lighted opening in it. In that way there will be obtained trees which have been used to an abund-

ance of light and air, and so will suffer less through their new surroundings differing from their original environment. The greatest care should be taken to get trees with a good root-system. It will be well to remove quite a large mass of earth around the roots, so as to interfere as little as possible with the connections formed between the roots and the soil; in fact,

trees can be transplanted at almost any season if a good large ball of earth is left around the roots. The greatest care should, of course, be taken that the roots should not be allowed to dry out, especially in the case of evergreen (coniferous) trees. In other respects the directions already given for planting the trees should be followed.

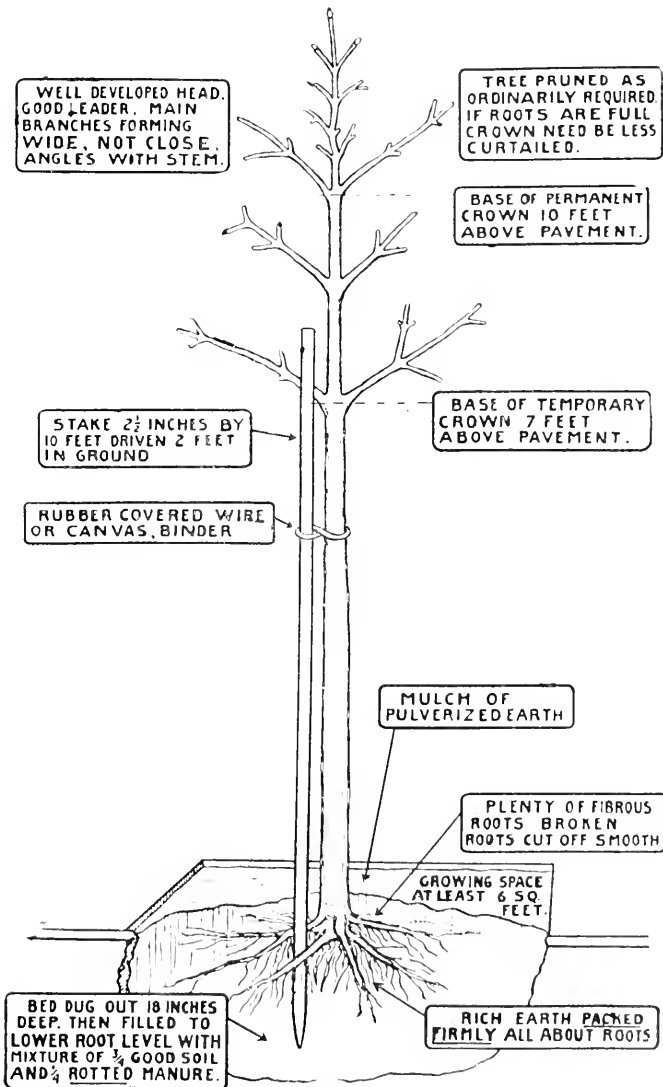

Picture by courtesy American Forestry Assoc

THE RIGHT WAY TO PLANT A TREE.

## SUGGESTION FOR MEMORIAL PLANTING OF TREES IN PARKS AND OTHER PLACES

*Submitted by Mr. C. Dolph, President, Metal Shingle and Siding Ct.,  
Preston, Ontario.*

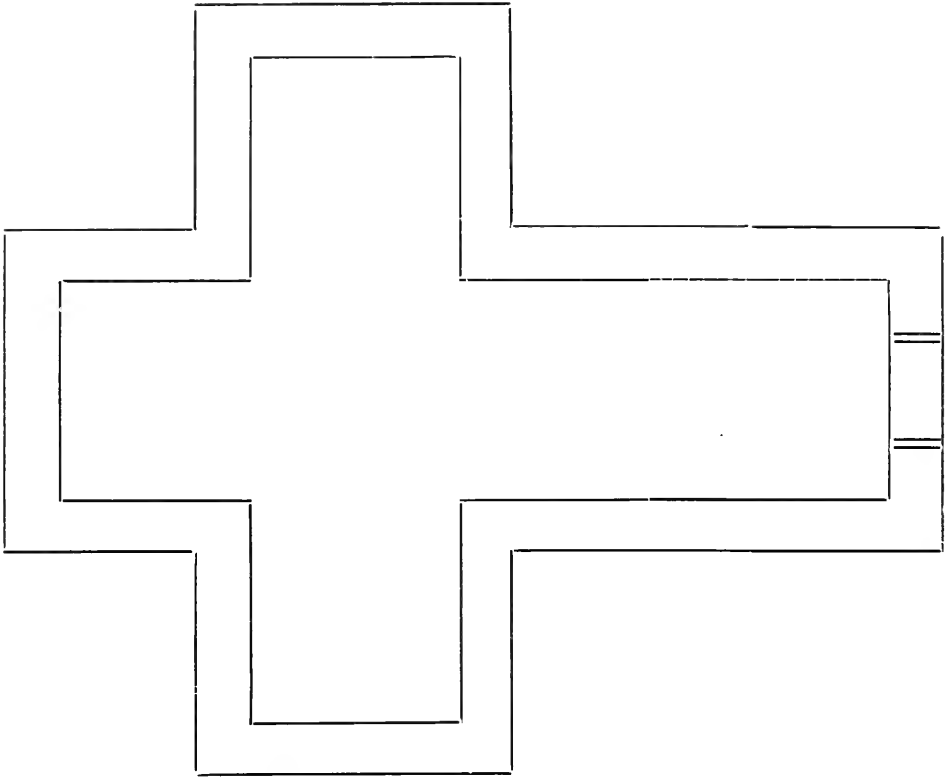

To take the form of a Cross or Church. Inner row of trees to be planted so that in course of time they will form cathedral effect. Inside row, possibly elms.

Outside row of trees may differ from inside row, possibly pine or any evergreen.

Inner space to be nicely levelled and seeded. Space between rows of trees to be kept as a walk with seats here and there.

Rough stone monument in centre with names of fallen heroes, or possibly all enlistments in smaller towns.

Surroundings may be planted with clumps of evergreens, shrubs, beds, etc., as circumstances may warrant.

Committee to select location and procure trees through park board, but patriotic citizens to pay for a tree and help plant it and mark it as their own.



Courtesy Water Powers Branch, Ottawa

ON THE BEAUTIFUL WATERS OF THE INTERIOR OF BRITISH COLUMBIA

- |                                 |                              |
|---------------------------------|------------------------------|
| 1. Sunset, Campbell River, B.C. | 3. Campbell River, B.C.      |
| 2. Little Qualicum River.       | 4. Adams Lake, looking north |

## HOMING PIGEONS FOR REPORTING FIRES

The Standardization Committee of the Canadian Forestry Association has under consideration the employment of pigeons to be used in carrying fire reports from the field to ranger stations. Full information on the subject is being obtained and a bulletin will shortly be issued on the subject which will be available to all interested. It is also hoped to have experimental work carried on during the present year.

The Dominion Parks Branch have recently been in communication with Mr. P. E. Edleman, electrical engineer, New York, and Commissioner J. B. Harkin in transmitting an extract from a letter received from Mr. Edleman, has the following remarks to make:

"Mr. Edleman recently wrote me suggesting that as homing pigeons had proved so effective in the recent war, that there appears to be no reason why they should not be adopted for forest fire protection work.

### First Step in "Wireless."

"While I think wireless telegraphy or telephones will eventually be adopted for communication in connection with forest fire protection, it strikes me that in the meantime the use of pigeons would offer a simple and cheap means of communication between points at present without other means of communication. Attached hereto is an extract from Mr. Edleman's letter explaining his scheme:

"I propose simply to set up one or more homing pigeon stations or nests. Two birds will be carried by each ranger and when he needs help he will release one, then ten minutes later the other with message. The birds fly at once to headquarters to which they have been trained, at about fifty miles per hour, and as proven under far more difficult battlefield conditions than are ever likely to be met with in your parks, are 98 per cent perfect. The birds can stand the most severe weather without harm. In this country young birds cost under \$10 each and trained birds, good ones, about \$25 each. They live about 14 years. An ingenious system of working has been developed, so that absolutely reliable results are obtainable. No special experts are required, except one man to look after the whole system in a given area, as he can readily train the men sufficiently to handle things right. The men will carry the birds on a special holder lightly strapped to their backs or other suitable manner. The up-

keep is insignificant, as the food for a bird for a whole year costs only about \$2.00 or under 20 cents monthly. The birds are clean and healthy and will be treated as pets by your men, especially as they come to know their value.

"I realize that every new plan is likely to be doubted, but here is one so evident that as soon as unimpeachable and most up-to-date correct data came to my attention I at once remembered your problems and communicated the result to you.

### Returned Men Available.

"I would recommend that one man, who is a pigeon expert be hired to look after the entire system and teach your other men the essentials, as they can learn them far easier than they could learn a telegraph code or the handling of a telephone system. This man should preferably be a returned soldier, who has been with the army homing pigeon service and previously handled pigeons as a hobby, as it takes a good man to make the plan a success. Such a man would gladly work for a nominal fair stipend and welcome the opportunity. It makes no difference as long as a good pigeon man who is wide-awake is put in charge of the system. The birds are kept in trim by continued practice from time to time.

### OUR DOMINION PARKS.

The Dominion parks of Canada, which are maintained as wild-life sanctuaries, include an area of 7,927 square miles, or more than 5,000,000 acres, nearly equal to one-half the total area of Switzerland, almost as large as Belgium, and nearly 1,000 square miles greater than the area of Wales. Jasper Park alone, which includes 4,400 square miles, is larger than Montenegro and almost twice the size of Prince Edward Island.

### FROM A NOTED FORESTER.

"Allow me to congratulate your Canadian Forestry Association on the extraordinary progress it has made during the war, and the improvement in your Journal. You have no doubt heard of the almost startling advance that has been made in forestry in Australia during the war period.

Very truly yours,

D. E. HUTCHINS.

Wellington, N.Z.



**A LIVE FOREST MEANS LIVE JOBS**

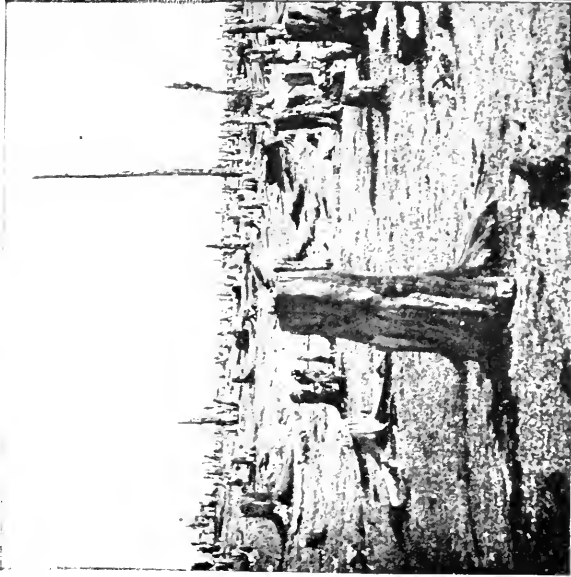

**A DEAD FOREST DRIVES OUT POPULATION**

**KEEP CANADA A COUNTRY OF LIVE JOBS**

Forest fires rob the workman, the merchant, the farmer; no citizen escapes the tax collected by these needless conflagrations. Forest fires are just grown-up camp fires, grown-up cigarette stubs, grown-up match-ends. No patriotic citizen needs to be told more.



THE FOREST AND THE WATER POWERS OF BRITISH COLUMBIA.

- 1. Stamp River.
- 2. Hazel Creek, Toba Inlet; 800 feet fall in view; typical of many streams as they descend from "hanging valleys".
- 3. Little Qualeicum River.
- 4. Chehalis River Bridge at Upper Canyon.



## A BUSINESS PLAN FOR WESTERN FORESTS



### How United States Government Placed all its Natural Forests Under Forestry Control— An Analogy for Canada



"When the Dominion Forestry Branch was first organized, the Dominion Government's obvious intention was to give the then 'Superintendent of Forestry' supervision of licensed timber berths. This has become a dead letter. The timber berths are operated by the 'Timber and Grazing Branch' of the Department of Interior, and on these large areas (approximately 6,680 sq. miles) there is little, if any, attempt to impose those forestry regulations which alone can maintain these areas as sources of timber supply."—March issue, Canadian Forestry Journal.

With the foregoing as its text, the Journal wishes to carry its point one step further. The claim that the forestry operations on the public-owned timber lands governed by the Dominion Government should be subject to the Dominion Forestry Branch has been sounded so frequently in days ante-dating the present Government as to remove our protest from even the suspicion of politics. What is wrong to-day has been wrong for many years. The correcting of this wrong is a matter of high public importance. What has been allowed to occur on the timber berth operations divorced from any supervision by the Government's timber conservation department (the Forestry Branch) is no whit different from what occurs on the Crown timber lands of Ontario. Whether in Ontario or Saskatchewan, the public interest is not served by further toleration of a destructive policy in respect to the timber properties.

#### Is Revenue Collecting Enough?

The United States faced a situation closely analogous to that now obtaining in the Department of the Interior of Canada. Washington, like Ottawa, maintained two branches to deal with national forests. Like Ottawa, one branch identified itself with constructive forestry, while the other looked upon the forests under its charge as a silver mine to be gouged out and

abandoned. It collected revenue; the operators collected the timber. Eventually at Washington this destructive scheme, that no market gardener would have put up with for ten days, was abandoned and the whole of the national forests were placed under the authority of the United States Forest Service. The end that has been achieved in the United States is precisely what the Canadian Forestry Association and the Commission of Conservation have been contending for during many years.

To give our nine thousand readers a clearer idea of how the United States reached the goal and what public purpose was served by the reform, the Canadian Forestry Journal wrote Col. Henry Solon Graves, Chief Forester of the United States. His reply follows:

"I am very glad to comply with the request in your letter of April 30 to give you a brief statement in regard to the benefits of the combination of the administration of the National Forests of the United States and the technical Bureau charged with investigations in forestry, lumbering, forest fires, etc.

#### Forests Minus Foresters.

"It was not until 1891 that recognition was given to the need of holding forest lands in Federal ownership for the purpose of timber production and watershed protection. In that year an act was passed by Congress, authorizing the reservation of portions of the public domain, partly or wholly covered with trees or undergrowth, as Forest Reservations. It was not until 1897 that provision for the administration of these Forest Reserves was made and not until 1899 that actual administration was attempted. This administration was placed in the General Land Office of the Department of the Interior, the function of which up to that time had been to survey and dispose of the public lands of the United States. During the next six years the administration of these Forest Reserves, especially the handling of the timber resources on them, was handled with increasing difficulty, owing to the need of the practice of forestry

on them, while practically all the technical foresters were in the Bureau of Forestry in another Department of Government. There was, to be sure, co-operation between the departments, but it was obvious that the best ends could not be served so long as the technical foresters were able to function only in an advisory capacity. Consequently, on February 1, 1905, the administration of the Forest Reserves (which have been since designated as National Forests) was transferred to the Department of Agriculture and the Forest Service formed by a combination of the former Bureau of Forestry, which had been chiefly an investigative organization directly charged with the handling of the resources of the forests. The General Land Office retained jurisdiction over the public domain but outside of Alaska has never attempted to sell timber on it, nor has this been necessary, since under our laws it has been possible to purchase land and timber from the unreserved public domain cheaply.

#### Good Management—This.

"The net effect of the transfer has been to assure the handling of the timber sales on the forests in accordance with the best principles of forestry so that the future production of timber on the areas cut over would be assured. With the widely varying stands in different forests, this has meant in practice an equally wide variation in the methods of cutting designed to secure this future production. In fact, this co-relation of the methods of cutting and of the restrictions on purchasers to the kind of stand in which the operation is conducted is one of the chief reasons why the work of administering timber sales should be in the hands of technical foresters. If all stands were alike, it would be relatively easy for the technical forester, acting in an advisory capacity, to draw up a set of rules which could be uniformly applied. Congress, however, very wisely stipulated in the Act of June 30, 1897, merely the objects to be accomplished and left the means by which these results were to be secured almost wholly to the discretion of the administrative officers. The result has been that where conditions permitted, the removal of only the mature and over-mature timber has been allowed, thus leaving the younger and thriftier trees to grow until they in turn become mature. In other stands it has been necessary to start new crops of trees and the cutting removes most of the present stand, leaving, however, ample seed trees. It is frequently possible to find both these general forms of cutting on the same forest in stands of

the same species, since each stand is examined before the sale is made by technical foresters and a plan of treatment outlined in accordance with the age and condition of the stand.

#### Managing a Nation's Forest on a Proper Plan.

"On the ground, the result has been that the future productivity of the areas cut over is assured. Between 700 million and 800 million feet of timber are now being cut annually in the National Forests, and this amount is certainly to be increased in the future rather than to be decreased. On some forests stands which were cut over some years ago, with the reservation of the younger, thriftier trees, are now being cut for a second time. In other cases, where clean cutting, with the reservation of seed trees, was permitted, there are good stands of small seedlings which are rapidly growing and which will make good timber in the future. Of course, perfect success has not been secured in all cases but, in general, the **results vindicate the wisdom of placing the administration of these areas in the care of the technical forestry branch** of the Federal Government, which has been charged with the co-relation of present timber use, future timber production, continuous use of the forage crop, in so far as it does not interfere with the other purposes for which the Forests were created, and the protection of the flow of streams rising within the Forests."

H. S. GRAVES, *Forester*.  
Washington, D.C., May 7, 1919.

#### Canada's Dual Control of Forests Outlived.

It will be seen from the foregoing that the developments in the United States have been parallel in important respects to those in Canada, to the extent that for many years, in both countries after the importance of forestry was theoretically recognized, the administration of publicly-owned timber, on forest reserves, was entrusted to a non-technical organization, notwithstanding the fact that there was in existence a technical forestry organization which, according to the logic of the situation, should have been given the opportunity to handle this work along scientific lines. Such matters are, of course, in a somewhat less developed stage in Canada than they are in the United States, and it is, therefore, natural enough that the step of placing forestry in the hands of the established technical forestry organization should come somewhat later in Canada than was the case in the United States.

It should also be noted that this transfer was brought about in the United States only as the

direct result of years of agitation by the American Forestry Association and other public-spirited organizations, which recognized fully the anomaly of the existing situation. The Dominion Lands Act, Section 58, would appear to confer upon the Dominion Forestry Branch jurisdiction in technical matters. However, if so, this provision has not been made effective as to licensed lands. Cutting on these lands is thus allowed to take place without due regard to the interests of the future, which demand that operations be conducted in such a way that the forest shall be perpetuated. The Dominion Government can take but partial credit for the practice of conservation upon its forest lands so long as this condition is permitted to continue.

### An Heirloom Policy.

It should also be emphasized that the present anomalous condition is a heritage from former times, when the importance of conservative methods of cutting was not realized. The present agitation for a change in this respect is, therefore, not in any sense a criticism of the existing Government, but is calculated to educate public sentiment to the point where it would approve action by a progressive Government in the direction of correcting the mistakes of previous administrations. The transfer of the administration of technical forestry work on licensed timber lands to the Dominion Forestry Branch would constitute a land-mark in the forest history of Canada, which would reflect very great credit upon the Government which should make such provision. It is believed that the time is now ripe for action along these lines. It should be noted that this action has been recommended by the Commission of Conservation during the past five years, also, of course, for years by the Dominion Forestry Branch, as a departmental matter.

### HANDLING WESTERN FORESTS.

*Editorial in the Winnipeg Tribune, April 18, 1919.*

"As things have worked out in Canada, the administration of the best timber areas on Dominion lands has been left under the administration of the old timber office which has in view mainly the collection of revenue and the timber operations have been carried on with little or no supervision and with almost no regard for the conditions that will follow the operations or for the production of a new crop. This means that the present crop of mature timber which does not cover more than thirty per

cent of the area usually shown as timbered, is being steadily reduced every year without any careful consideration of what is to follow or how the crop is to be perpetuated.

"It is suggested that before any tract or forest is put up for sale or operations authorized on it thorough information should be obtained on the following points: (1) The probability of a market for the products; (2) the conditions of climate, wind and soil; and (3) the composition of the forest as to tree species and the relations they serve toward one another. It is only after information of this kind, which will vary considerably on every tract of forest, has been obtained that the formulating of a proper working plan designed to perpetuate the forest and increase its production is possible. The present administration of a great natural resource is, in the opinion of many, behind the times."

### WOOD FOR AEROPLANES.

The American Lumberman feels confident that the manufacture of aeroplane spruce is due for a great revival. "Therefore," it says, "lumber manufacturers who have during the war gained experience in the production of airplane lumber should keep an eye on the future and develop this field. The most successful and satisfactory building material for an airplane is wood, but that wood has to be perfect and correctly handled. If supplies are hard to obtain or if they are not satisfactory in character the manufacturers of airplanes will turn to other materials. For example, a Frenchman already has perfected an airplane made entirely of steel and it is said to operate successfully. Practically 6,000,000 motor vehicles were in use in the United States at the beginning of the year and it may not be many years before that many airplanes are in service in this country. Think, therefore, of the wonderful field for lumber that there is in the expansion of the aircraft industry."

### WARNING!

**T**HIS is a bad season for forest fires.

**Watch your campfire and your cigarette.**

**Every forest fire puts somebody out of work.**

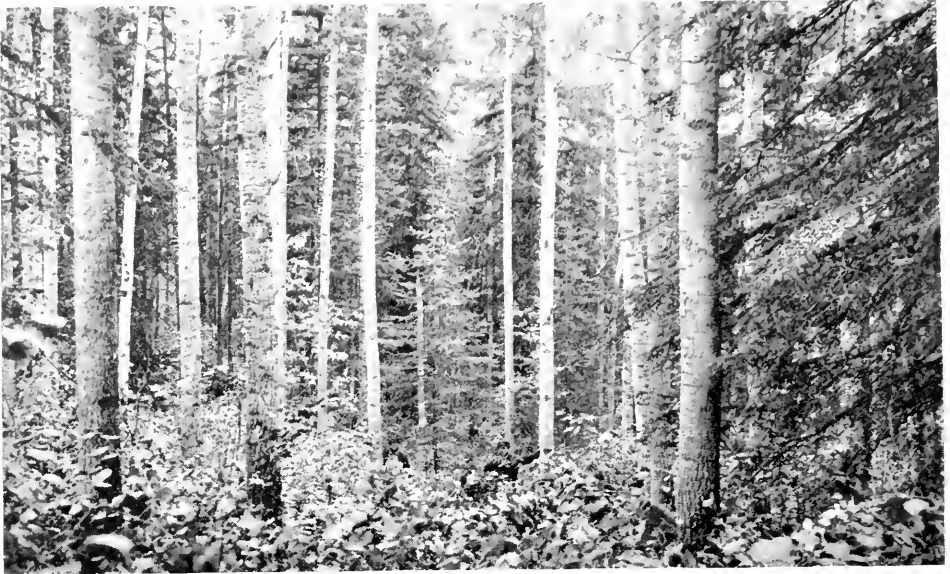

A fine stand of spruce and poplar in the Porcupine Forest Reserve, Saskatchewan.



A Scotch Pine plantation on a Dominion Forest Reserve, badly damaged by rabbits.

## A PROPOSED BRITISH EMPIRE FORESTRY ASSOC.



Would Act as a Link Between Progressive Societies in all Parts of British Dominions



Some months ago, the Secretary of the Canadian Forestry Association offered the suggestion that the forestry activities of all parts of the British Empire might well be brought into closer relationship by the forming of a "British Empire Forestry Association". The proposal was submitted to leaders of the forestry movement in Great Britain, Australia, New Zealand, South Africa and India. The hearty reception accorded to it may be gauged by the excerpts from letters printed herewith. Other letters will appear in the June issue.

Although the Anglo Saxon peoples have been the last to admit forestry to its rightful estate, one would be a wilful reactionary to deny that recent years have worked remarkable changes. Forestry is coming into its own. The painful lessons of war experience have accomplished more for forestry in the British Isles than a half-century of warning and advice. Much the same is true of Australia and New Zealand and Canada. The era of the explosive orator and his "unscratched resources" has given place to the counting machine and its cool recital of facts and figures. From the Rocky Mountains to the Atlantic, Canada has been spending forest capital without any concern for the next holder of the purse. To realise cash from tree trunks has been the extent of our business science and even at this hour is mostly the measure of our forestry practice. The story of similar public attitudes and action is monotonously applicable to nearly every part of the British Empire except India.

### Applying the X-Ray.

This is the day of X-Ray examinations. Because a policy is old and in the good graces of a few rucky administrators or a commercial or political sect is almost the best reason why it should be put on the operating table and have its anatomy photographed. Certainly the people of the overseas Dominions who are yet legal masters of their forests are in a mood to examine the merits of a forestry programme in its re-

lation to the public interest. There has never been any question that an intelligently guided forestry policy is the keystone of state management. The great trouble appears to have been that a people habituated to mere exploitation and sudden profits in their private experience has to pass through some such metamorphosis as the war provided in order to appreciate the meaning of foresight and patience. All our public issues bearing on elections have been tied to immediate causes and immediate consequences. Forestry cannot be compensated in a five-year calendar. We have been treated to scandals of waterless canals, sawdust wharves, "plundering the treasury" and so forth, because these things are pictorial and easily visualized by political and economic children. Nothing but the solemn times of 1914-19 could have made Canadians willing, as they are to-day unquestionably willing, to study national economics and sit humbly in the school-room of international and historical experience. Because of this changed attitude, because of this new patriotism that wants facts and perspective in place of tosh, the swift development of forestry science in Canada is to be regarded as one of the certainties in the new order.

### The New Association.

The British Empire Forestry Association, which is yet unformed and only in a stage of discussion, would aim to relate the forestry movement in all sections of the Empire. It would act as a clearing house for mutually-valuable information and would place at the disposal of all foresters whether in the British Isles or Canada or Burma news of common problems and solutions.

More than this, it would bear a very important relation to the development of timber trade within the Empire. For example, the amount of misconception regarding Canadian woods in the British Isles and Australia and New Zealand, the lack of knowledge of important Australian woods in other parts of the Empire,

have played into the pockets of foreign timber salesmen continuously. To penetrate this veil of darkness would indeed be a service worth reckoning.

We give herewith part of a letter received from Hon. R. T. Robinson, K.C., Minister for Forests, of West Australia:

Perth, West Australia, Jan. 30, 1919.

"The basic purpose which is the genesis of your society has my heartiest sympathy. By no means the least important of the lessons of the war to the Empire is that which has reference to forests. It appears to me also that no war-lesson has been so widely appreciated and understood. Evidences of this are everywhere visible. Your Association is one, and, in Great Britain, the Forestry Sub-Committee of the Reconstruction Committee is another. I have perused the report of this sub-committee with the deepest interest, and noted with satisfaction that its recommendations embody the sound forestry principles advocated by such able exponents of national forestry as Lord Lovat, Sir William Schlich and Sir John Stirling Maxwell.

"In Australia, war experience has awakened a forest conscience in quarters which had previously been impervious to argument and irresponsible to considerations of national economics. Here, too, the evidences of the existence of a new and better spirit towards forests are many. In 1916 New South Wales passed an admirable Forest Act; since then Victoria and this State have done likewise. The measure put on the Statute Book of Western Australia some six weeks ago is designed to put an end to reckless exploitation and to foster and cultivate our great forest heritage so that it may be the basis of great industries for all time.

"An Empire Association such as you outline is, in my opinion, a step in the right direction. There are many matters in regard to which mutual help and advice would be of value, and an Empire Forestry Association would act at once as a sort of Forestry Clearing House and Information Bureau. Mr. C. E. Lane-Poole, Conservator of Forests here, is at one with me in this matter, and he will be very pleased to help in any way he can."

#### CHANGING THE OLD ORDER IN AUSTRALIA.

The following letter was received from Mr. C. E. Lane-Poole, Conservator of Forests, Western Australia:

"My Minister has handed to me your letter of the 15th November last, in which you furnish some details regarding a projected British Empire Forestry Association designed to bring into closer co-operation the various forestry departments and associations throughout the Empire. The idea appeals strongly to me, as I am fully convinced that it is only by systematically educating public opinion that the true relationship between forestry and national economy will be brought home to the various people within the Empire.

"I understand that my Minister is writing to you by this mail and is giving you some information as to what has been done here and also has added some suggestions whereby the objects of your proposed association may be helped so far as Australia is concerned. In this State the public conscience has only of recent days been aroused to the vast importance of the country's great natural forest heritage, and those engaged in the work of forming public opinion have been met by an almost impenetrable wall of prejudice and ignorance.

"Since the foundation of the colony of Western Australia 90 years ago, the belief has prevailed that the forests of the country are inexhaustible and this belief has found expression in the cruel and destructive methods of conversion. Exploitation in consequence has been carried on with a recklessness that has reduced the forest wealth very materially. But a better state of things is coming about and, aided by a Forest Act, passed in the end of last December, I have hopes that we shall be able to repair much of the damage done in the past, and to adopt a policy for the future, which will ensure a continuance of this State's position as the premier timber exporting State of the Commonwealth group.

I observe with pleasure from Canadian journals that come under my notice that in each of your provinces, measures for preserving and strengthening the forest asset are in active progress, and, more particularly, I notice with satisfaction that the danger from fire is assessed at its true worth, and that measures are taken accordingly. In Australia Scientific forestry has much to contend with on this fire question, owing to the utterly erroneous opinion, held in many quarters, that a fire through the forests is a really good thing for it."



On Coquitlam Lake, British Columbia.

## WILL PLANTING PAY IN BRITISH ISLES?

*By H. J. Elmes in a Discussion of the British Government's Forest Planting Projects.*

I think we have no sufficient knowledge of the actual extent of untouched virgin forest in the north of Europe, or of the future cost of cutting that timber on the English and other competing markets, but we do know that these forests under reasonable protection from fire and over-cutting, such as have been adopted in Norway, Sweden, some parts of North Russia, and in the Dominion of Canada, will pro-

duce, and continue to produce, by natural regeneration without any other outlay, spruce and pine of a higher quality than we can grow in most parts of the United Kingdom. We also know that where this timber can be floated or partly floated, to the shipping ports, it can be landed in England at costs for freight, cheaper than it can be conveyed by land from many parts of England to collieries and centres of

consumption only 50 to 100 miles distant, and it was stated in a very able paper in the *Timber Trades Journal* that it was possible to purchase in Sweden from lumber companies, the freehold of forests, from which all the then saleable timber had been extracted, but which were well stocked by natural regeneration with young trees, which in 30 to 50 years' time would be ready for the market; at a much lower price than the bare land without any timber on it could be bought in England. And I believe that this will be found equally true of vast areas in the Dominion of Canada and Newfoundland, which have been more or less logged over, but from which at the prices ruling before the war it would not pay to take out any but the best logs, and I quite agree with the suggestion that this point. Another important area of which the Canadian Government must be consulted on the future production is very indefinitely known are the districts on the French, Spanish and Portuguese coasts, which have hitherto supplied almost the whole of the pit props for the great Welsh collieries.

---

### SOLDIERS TAKE GOOD POSITIONS.

Lieut. H. C. Kinghorn, of Fredericton, N.B., has accepted a permanent position with the New Brunswick Crown Land Department. Mr. Kinghorn is a graduate of the University of New Brunswick in Forestry in 1911, and has had extensive experience with the Dominion forest service and British Columbia forest service. Mr. Kinghorn resigned from the forest service of British Columbia in May, 1916, to enlist in the 58th Battery Canadian Engineers.

Lieut. H. S. Laughlin, B.Ss.F., of Milltown, N.B., has also accepted a position with the Forestry Department. Mr. Laughlin graduated in 1914 from the University of New Brunswick, and joined the British Columbia forest service, enlisting in November, 1915. Lieut. Laughlin was in charge of forestry work in District 5, Canadian Forestry Corps, France, and has been highly recommended by his superior officer overseas.

Capt. A. J. McIntyre, of Campbellton, an ex-locomotive engineer and machinist, who recently returned from overseas, has accepted the position of inspector of Fire Protective Appliances on Locomotives for the Forestry Department of the New Brunswick Government. Mr. McIntyre, by co-operative arrangement with the

Railway Commission, is also District Fire Inspector for the commission. His duties involve the periodic inspection of the nettings in the smoke-boxes of locomotives and also ashpans. Over 200 locomotives operate in New Brunswick, owned by the C.N.R., C.P.R., Caraquet, Temiscouata, Kent Northern, and Fredericton and Grand Lake Railways. His work also covers the supervision of more than twenty railway fire patrolmen. Mr. McIntyre's work is especially concerned with forest fire protection.

Pte. H. C. Lynn, also a returned soldier, has accepted a position as assistant railway fire patrolman.

---

"To bring the matter closer home it is plainly up to the people of Cape Breton to take active part in conserving our fine stretches of woodland and forest. At present they are disappearing rapidly."—Sydney, N.S., Record.

---

### RETURNED OFFICERS CHOSEN.

Major D. D. Young and Major James Brechin have been appointed by the Provincial Government to positions as British Columbia Market Commissioners, associated with the Trade Extension Department of the Forest Branch. It will be the duty of these two officials to cultivate the prairie and Eastern Canadian market, and generally to conduct an aggressive campaign for British Columbia forest products. In conjunction with a generally extended campaign for business in Canada, it is the intention of the Minister and of the Trade Extension Department in particular to study the world's lumber market, the Government realizing that if this province is to expand her trade in the products of her forests it will be necessary for the department to keep itself intimately posted upon world conditions particularly during the reconstruction era, when the demand for lumber is abnormal.

---

### BRITISH COLUMBIA'S LUMBER SALES.

The 1918 value of the lumber output was \$54,162,523, which was almost double that of 1915, and 12 per cent greater than that of 1917. The total production for the year was shown as 1,545,422,000 feet. Since 1915 the lumber cut has increased over fifty per cent.





Taking two-year-old Jack Pine out of the nursery beds to plant on a Saskatchewan forest reserve.



Planting Jack Pine seedlings in furrows on a Dominion Forest Reserve.

# A LAND OF FORESTS—WITHOUT FORESTRY

By Dr. C. D. Howe, Faculty of Forestry, Toronto,  
in Address to Toronto Board of Trade.

## “Canada Stands Almost Naked of Any Forestry Practice—A Plain-Spoken Indictment of Forest Management

Not long ago I attended a meeting of business men and university professors gathered to listen to reports upon the progress of industrial research in Canada. Being Toronto business men and, therefore, doers as well as seers, some of them seemed inclined to express impatience that matters in the hands of the Research Council at Ottawa had not developed more rapidly. One of the gentlemen made the remark: “Canada stands almost naked of industrial research, of co-operation between the scientists and the business men.” Another, in replying, said, in effect: “We must have patience. New ideas develop slowly”. Then to use what he doubtless considered a convincing illustration, he remarked, with a great deal of emphasis: “I remember 25 or 30 years ago we had to be told what forestry meant. It was an entirely new thing. Now, every big lumber company or pulpwood concern has a forester. They could not do business without one.”

The statements of these two gentlemen made a deep impression upon me, the first because of its terse descriptive quality, and the second because of the profundity of ignorance which it displayed. Since the second statement reflects a very general public opinion with regard to forestry in Canada, I shall combine it with the first and make the remarks quoted the subject of my text and I shall say: After nearly 30 years of agitation and effort Canada stands almost naked of any forestry practice, of any definite, carefully formulated plans for the management of forests.

I make this statement deliberately, although I am aware that it will evoke criticism and perhaps censure. I believe the time is ripe for plain speaking. **The forests of the Dominion chiefly rest in Crown lands. They belong to you and you should know into what state their past and present treatment has brought and is bringing them.** You should demand an account of stewardship.



Dr. C. D. Howe, Faculty of Forestry,  
University of Toronto.

### Forestry Practice Means—

To make myself clear and to avoid misunderstanding, let me define what forestry practice means. The primary object of forest management is to maintain unimpaired the capital stock, the forest wealth. Herein lies the difference between lumbering and forestry. Lumbering removes the trees with no thought of a future forest crop on the same area; forestry practice removes the trees only after careful planning for the future crop. When this fundamental object has been accomplished, the next procedure in order is, if possible, to increase the earning capacity of the capital invested in the forest. Although minor objects and methods of technique may differ under varying circumstances, these are the two elemental principles at the base of all forestry prac-

tice. Keep the capital intact, so that its returns will be as continuous as possible; increase the earning capacity of the capital. Nothing about that is hard for a business man to understand! In fact, someone has defined forestry practice as the application of business principles in obtaining the continued productivity of woodlands.

### Cutting Coupons—and Cords.

Suppose you had an acre of land covered with trees of commercial value. Now, trees possess the miraculous power of rejuvenating themselves each year and the result is a layer of new wood. Let us suppose that the new wood laid down in a growing season on all the trees of an acre totals a cord—a cord of wood per acre. You could remove a cord of wood each year and your capital stock would remain unimpaired. You could consider that cord of wood as earnings on capital invested or you could imagine yourself cutting coupons instead of cords. And the wonderful thing about it is that you, your children, or your children's children could go on doing this as long as the sun shines and the rain falls, for wood is only solidified sunshine and water plus a small percentage of mineral salts from the soil. I will substitute for the words you and your children the term, the state, the nation. I confess I can never pass this point without dreaming of what might be if men only demanded in governmental business the same standards that they insist upon in their private business.

The primary object of forestry practice, then, is to maintain the capital stock in a productive condition. I take this to be the foundation upon which all legitimate business rests—the security of the investment. As business men you make this your initial demand upon the state. Do you or have you made the same demand in behalf of the forests in which you are part-owners, which yield revenues to the public treasury, and so indirectly reduce the cost of carrying on your business, whatever it may be?

### Some Business Data.

Perhaps you have not the data at hand. Let me answer the question for you. One-third of the geographical area of Canada doubtless is incapable of producing trees of sawlog size because of the inhospitable climate or soil conditions. The actual sawlog producing areas probably do not total 500,000 square miles, and at least one-half of this has been burned. Any of you who have travelled in the north country or who has even ridden on the trans-

continental railways must be fairly well convinced that our forest capital has not been maintained unimpaired and therefore, according to our definition, the primary object of forestry practice has not yet been attained.

The capital values destroyed by fire are incomprehensibly large. The effect of this loss of wealth upon industry is already apparent, for it has forced lumber concerns to seek materials each year farther and farther from the market, which means that the consumer has to pay more and more each year for the products of the forest. We are using in Toronto forest products whose raw material came from the other side of the height of land in the Hudson Bay drainage basin. Think of the transportation charges on that material! I see in this room wood material which came from the Southern States. The wages expended in converting the raw material into the finished product went to the citizens of another country and yet those wages might have gone to our own citizens; we could have the raw materials better adapted for the purpose within 200 miles of Toronto, if we had taken the first step in forestry practice, that is, had we maintained our forest capital unimpaired.

### How the Consumer Pays.

We as consumers are paying heavily to-day for our neglect of this elementary business precaution, yet the failing of timber supplies through the devastation of forest fires is not the most serious aspect of the problem. Mother nature is a great restorer; if undisturbed, she eventually heals all wounds, and in time she might recover our fire scarred forest areas with commercially valuable trees, but, unfortunately, she is not allowed to carry out her plans. The forests are burned not once, but repeatedly. I know areas that have been burned thirteen times in the past 50 years. The repeated forest fire is a vicious and destructive thing, for it kills the young trees which are to make the future forest and it kills the mother trees (seed trees) which might, if allowed to live, replace the destroyed young.

One-half of our commercial timber lands have been burned. You see, even if there never were another forest fire, one-half of our future supply of timber should come from these areas. Every fire decreases that possibility by destroying the young commercial trees. You cannot kill the children for several generations and look forward to the continuance of the race; you cannot kill the young pine and the young

spruce on an area every 5, 10 or 20 years and expect eventually to get saw logs.

### **Killing the Forest Children.**

Let me state once more the conditions on the burned areas: Thousands of square miles of forest land in the Dominion have been so severely burned by repeated fires that they will lie barren of commercial trees for hundreds of years unless they are planted by man. Other thousands of square miles, less seriously burned, are restocking themselves naturally to valuable species, but these areas are being constantly reduced and transferred into the first class mentioned because of inadequate fire protection.

I asked you a moment ago, if you had demanded security for the Canadian forest capital in which you share. Have you? You have spent a million dollars a year for the past ten years for protection of your property. You have invested ten million dollars in a certain project. Have you asked for an adequate return on that investment? Let me tell you, although you have spent millions of dollars on forest protection, the safety of the forests is still largely in the hands of Providence. I mean it depends upon weather conditions. Things go fairly well until we have an exceptionally dry season. The technique of fire-fighting methods has not been sufficiently developed to cope with the extra dry season. A very effective preventive method, although successfully practiced in certain districts in the West, has not yet been employed other than experimentally in the East, namely the disposal of the slash which becomes extremely inflammable in softwood forests, as in the north country. Unless the slash in certain districts is burned at the time of lumbering, we may as well become resigned to periodic forest holocausts. The best fire-fighting organization in the world could not master a situation in which all the odds were against it.

### **The Patronage Millstone.**

Another reason for this insecurity of the forest, the reason more time and thought have not been put upon the development of fire-fighting methods is largely because the rangers are not hired because they are efficient workmen or even good fire-fighters—but for other seasons.

I have only words of praise for the men in charge of the Dominion and Provincial Forestry Branches. There are men at Ottawa; there are men here in Queen's Park, men in nearly every provincial capital, hard working, patriotic men who are giving the best efforts of their lives in the attempt to protect our forest capital, but

they are far from successful because in the end they find astride every trail that hideous grinning monster, political patronage. Who is to blame for this state of affairs? Now, I have thought over this matter a good deal, and I have come to the conclusion that no politician, no official of the government is to blame; they are simply the victims of an inherited political tradition with regard to the methods of handling government business. You and I are really the responsible parties. The average citizen is to blame because he does not demand in government business the same standard that he demands in his own private business. Political patronage is a question of public morals and the problem will be solved only on this ground.

If, as an organization, you are contemplating presenting a memorial at Ottawa or in Queen's Park on this subject, I make bold to suggest that you state the case something like this: Our forests are in a precarious condition. Unless they are relieved, their revenue-producing function will be practically destroyed because of repeated forest fires. We believe this condition is chiefly due to an archaic, inefficient, rotten system of political patronage, a system for which you are not responsible because you inherited it from your political ancestors. In fact, we acknowledge that we as tax-paying citizens are really responsible for a condition of affairs for which we have in the past condemned you. Now, cannot we get together and devise some means of putting forest protection on a business basis. I have a feeling that the responsible politician, I mean the legislator and the cabinet minister are just as disgusted with the whole business as anyone else, and that approached in this manner, they would meet you more than half way.

### **What of White Pine?**

Let me say again that the first step in forestry practice is the maintenance of the earning power of the capital stock. This primary object has not yet been accomplished in Canada because we have not yet devised the means and methods to make the forests reasonably safe from destruction by fire.

Now, let us turn to the unburned logged-over lands and see how our definition of forestry applies to their treatment. We have the testimony of lumbermen that the end of the white pine supply in Eastern Canada is in sight. There will be scattered white pine trees in the forests for many years, but outside the forest reserves only a few large stands of virgin white pine



At the junction of the Peace and Smoky Rivers, Athabasca Country.

remain. Investigations indicate that white pine does not reproduce itself when removed from the ordinary mixed forest. The young seedlings require light and the dense thickets that spring up after logging choke and finally kill the little trees.

Certain areas in the old pineries, that is, where the trees were in pure stand when cut, are undoubtedly regenerating themselves with pine, but we don't know how extensive such areas are. It is very important that we should know, but we don't know. We need much more investigation of the matter, but so far as the investigations have gone, they indicate that we have not accomplished the first object of forestry practice in respect to white pine, that is, we have not kept the capital stock represented by white pine trees unimpaired and continuously productive.

#### A Two-Thirds Reduction.

For the past two summers I have been investigating for the Commission of Conservation at Ottawa, the regeneration of spruce and balsam on cut-over unburned pulpwood lands in the Province of Quebec. I cannot here go into the details of my results, but I would like to tell you what we found on a certain representative area of 97 acres which had been severely culled. Twenty-six spruce trees per acre had been removed. We counted all the young trees on those 97 acres and determined their death rate. **We found when they reach merchantable size there will be only 7 spruce trees per acre**

**to take the place of the 26 spruce trees removed by the logging operations, or, in other words, there will be one-third as many spruce trees in the future forest as in the virgin forest.**

We don't know yet whether this area is representative of all the cut-over balsam lands in Eastern Canada. It is very important that we should know. If it is representative, then it will be very evident to you as business men that the forest capital stock represented by spruce trees has not been maintained unimpaired and continuously productive. Therefore, we have not accomplished the primary object of forestry practice in respect to spruce.

#### Balsam in Quebec.

Balsam trees at the rate of 32 per acre had been cut from these same 97 acres. Following the same line of investigation as with the spruce, **we found that in the next crop there will be 12 trees per acre where 32 have been taken away, or, in other words, there will be a little more than a third as many balsam trees in the future forest as were in the virgin forest.** Nor is this the whole story. Our investigations indicate that 7 of those 12 balsam will be so badly damaged by heart rot as to be unfit for pulpwood; **so the final result will probably be 5 pulpwood bearing balsam trees where 32 were taken away.**

We don't know yet whether this area is representative of all the cut-over balsam lands in Eastern Canada. It is very evident that we should know. If it is representative, then it is no longer necessary for me to bring to you any

more illustrations to drive home my assertion that we have not attained the first objective of forestry practice because we have not maintained the forest capital unimpaired and in a continuously productive condition.

### Who Should Manage the Forests?

Let me point out to you a great anomaly that very largely accounts for our present forest conditions. As business men you will appreciate the point. The Forestry Branch at Ottawa is charged with the care of 25,000,000 acres of Dominion Forest Reserves. It has a staff of technically trained foresters. With the exception of settlers' permits and a few odd logging jobs, the activities of the Branch are confined to fire protection. All the licensed lands, all the big logging operations within the forest reserves are in charge of another branch at Ottawa, which has not a forester in it. Let us come nearer home. The Province of Ontario has around 7,000,000 acres in forest reserves. It has 10,000,000 acres under timber license and practically the same area in pulpwood concessions. There is a Forest Branch with technically trained foresters. There are no better foresters in the Dominion, yet they have no part in carrying out the timber regulations for the licensed lands. That is in the hands of another branch which has no forester in it. Managing forests so that they will remain continuously productive is a big job; it calls for men with special ability and special training. Those of you who are manufacturers—to whom do you turn with your technical problems? Do you turn them over to your clerks?

### A Challenge to Business Men.

May I refer you back to my text: Canada stands practically naked of any forestry practice. The reason for this is that you and business men like you throughout the Dominion have not taken interest enough in your property to see that it is properly managed, to demand an account of stewardship. I think it is the part of patriotism as well as the part of elementary business policy to make an effort to sustain an industry which stands third as a producer of wealth in this country, an industry that created for Canada in 1917 forest products valued at \$116,000,000, an industry that employs over 50,000 people and distributes nearly 40 million dollars in wages. These are concerned with wood products as such. If we add to these sums the industries partially dependent upon wood in some farm, we find that they in-

creased the wealth of Canada in 1917 by over \$250,000,000. Surely in the interests of the continued prosperity of our country, the wheels of these industries should continue to turn.

### The Brighter Side.

Gentlemen, I hope I have not drawn the picture too dark. I have failed in my effort, if I have given you the impression that the case is hopeless. It is far from that. We are still much better situated in regard to timber supplies than any other country. but that does not justify indifference or the delay of recuperative methods. Four-fifths of Canadian soil is probably better adapted to the growing of trees than to any other purpose. No other country has such large forest areas, so accessible to transportation by water and by rail, so near the great consuming markets. Russia may have more timber; the United States undoubtedly has more and in greater variety, but I repeat, no other country has such large forest areas so near the great consuming markets of the world. With proper forethought and proper fore-action there is no reason why Canada should not supply the timber requirements of the world. Properly manager our great forest areas might turn for all time continuous streams of sylvan wealth into our public treasuries. But they never will; they will lie as idle waste lands, a burden upon the tax-payer, as so many of them already are, unless recuperative methods are inaugurated at once, unless you and the business men like you throughout the country take more interest in them in the future than you have in the past.

---

== TREES ==

---

Some trees drink deep draughts beside brooks,  
 Delighting in gurgle and black moisture;  
 Coolness and strength they draw up into their limbs  
 And pay it out for the passer-by to enjoy.  
 In the shadow and amplitude of their noble branches,  
 And in their clean, shining, exquisite leaves,  
 Thin and translucent for green light to trickle  
 through,  
 Harmoniously curved as musical instruments,  
 They instill fortitude by their robust trunks,  
 Moulded as individually as men's bodies;  
 Valiant and comfortable;  
 Some shaggy,  
 Some glossy as lithe animals,  
 All of them full of kindness and tree-humor  
 And the dignity that springs from belonging to  
 one place.

## A BETTER PLAN OF SELLING PUBLIC TIMBER



### Higher Present Revenues and Certainty of a Replenished Crop—New Brunswick's Experiment



The Crown timber lands of New Brunswick aggregate some 10,000 square miles, which bring in a direct annual revenue to the Government of around \$500,000. Hitherto, the typical Canadian method of timber disposal has been followed—the license system. Specific areas were put up for license, usually for a twenty-year period, but renewable more or less indefinitely, subject to the payment of a fixed sum per square mile per year as ground rent, a fixed sum per thousand feet as stumpage, when the timber is cut, and a bonus in a lump sum, payable following the sale, determined by competitive bidding; a fire tax is also levied, amounting to one-half cent per acre per year, which is supplemented by a levy upon privately-owned forest lands and by an appropriation from the Government. The essential point is that the soil remains in the ownership of the province, only the right to cut the timber being disposed of, under restrictions which are subject to revision at the discretion of the Government. There is thus every opportunity for the enforced adoption of improved methods of cutting, as rapidly as changing economic conditions justify the promulgation of corresponding regulations by the Minister of Lands and Mines.

#### The Timber Sale Plan.

A recent development is the reversion to the Crown of some 400 square miles of land previously held under license, because the licensees considered the lands to be so near exhaustion as not to justify the renewal of the licenses, with consequent obligation to pay the annual ground rental, bonus and fire tax, in addition to other charges. An examination by the forest service showed, however, that considerable amounts of timber still existed on some of these tracts, for which there was a strong local demand.

It was first intended that these lands should again be put up for sale as licenses, on the old basis, but after very careful consideration the plan was changed to a straight timber sale basis at public auction.

#### How the State Gains.

This sale was held early in October, 1918, and had the effect of fully justifying the tentative adoption of the new policy by the Government. Under the old system, the stumpage rate was \$2.50 per M. Adding to this the pro rata charge for ground rent, fire tax and bonus, the total revenue to the Government was in the neighborhood of only \$3.00 per M. At the recent sale, however, the prices bid for the coniferous species varied from \$5.50 per M. to \$7.75, according to the character of the timber and its accessibility. The estimated total revenue to the province will be \$70,000 for the 110 square miles disposed of. A diameter limit of 12 inches is prescribed for spruce and pine, and 9 inches for balsam. Two years are allowed for removal of the timber.

If this revolutionary change in policy proves as satisfactory in practice as now seems probable, its extension on a large scale may be anticipated in the future, with corresponding benefit to the revenues of the province. On larger sales, the time limit for removal must of course be extended. In case of long-time sales, provision would presumably be made for the periodical readjustment of stumpage prices, as is now done on timber sales in the National Forests of the United States, and as is provided for in connection with the sale of timber on provincial Crown lands in British Columbia.

#### Holding Worn-Out Lands.

It is to be anticipated that the reversion to the Crown of timber lands approaching exhaustion will continue, rendering feasible the increased extension of the timber sales policy. It is of course logical and inevitable that the province should, as a rule, have to hold worn-out lands for recuperation. The progressive exhaustion of virgin supplies in New Brunswick will greatly increase the area so held. The adoption of the timber sales policy may be expected to facilitate the practice of better forestry methods, calculated to ensure a more satisfactory regeneration of the most valuable species.

The logical procedure will be for the forest service to make a careful preliminary study of the conditions on each tract and prepare cutting regulations adapted to the local conditions in each case. These restrictions being known in advance of the sale, the prospective purchaser will take the additional cost of logging under these conditions into consideration when making his bid, so that in the long run the province will bear the added cost of leaving the lands in a productive condition. The adoption of such a policy as to timber sales may, as its benefits become realized, be expected to have a corresponding effect upon the administration of lands held under license, through the abandonment of the present rigid diameter limit, which does not, as a rule, give satisfactory results, and the substitution in its stead of a scheme of cutting based upon the local conditions existing upon each particular tract. This should mean, in the course of time, the marking of timber for cutting, under the direction of trained and experienced foresters, with a view to leaving the cutting area in the most productive condition feasible under the existing physical and economic conditions.

With a technical forestry organization already on the ground, and with the Provincial Government in the most hearty sympathy with its work, steady progress toward the more intelligent handling of Crown timber lands may confidently be expected.

#### WOOD BLOCK PAVING.

Wood block paving, which in European cities has long been the favorite, is increasing in use in Canada, despite the frequent clumsy methods used by town engineers in laying it. Rightly laid it is an ideal paving material.

#### LATE SPRING SAVES \$40,000.

(Toronto Globe)

Owing to the fact that there is still a good deal of snow in the woods, making it practically impossible for fires to get going, there is no need for rangers, and the department has decided not to send the men into the woods until the 15th of this month, or about 15 days later than usual. The saving amount to roughly \$2,700 a day.

## NOVA SCOTIA'S FOREST CROP, \$19,000,000

*It has been customary to estimate the annual value of Nova Scotia's forest products at \$5,000,000. Hon. O. T. Daniels, Attorney General and Commissioner of Lands, comes forward in an article in "Canada Lumberman" declaring that the old total is quite inaccurate. Mr. Daniels places the value of Nova Scotia's forest crop at nearly \$19,000,000.*

"The following list gives the estimated value of forest products for the province during the present season compiled from the best sources of information available:

|  |               |
|--|---------------|
| Lumber .....   | \$8,755,000   |
| Cordwood .....   | 5,250,000     |
| Staves, fish, apple, potato, barrels and boxes.....                          | 500,000       |
| Pulp .....   | 400,000       |
| Christmas Trees .....  | 50,000        |
| Hop Poles .....  | 50,000        |
| Pit Props and Booms.....   | 600,000       |
| Telegraph and Telephone Poles.....   | 50,000        |
| Railroad Ties .....  | 500,000       |
| Poles, Rails, Stakes, Posts and Boards for fences.....                       | 500,000       |
| Ship Timber and Knees, etc.....  | 1,000,000     |
| Laths .....  | 150,000       |
| Wharf Timber and Piling.....   | 100,000       |
| Shingles .....   | 100,000       |
| Miscellaneous as Weir Stakes, Clothes Pins, Tan Bark, Maple Sugar, etc. .... | 100,000       |
| Total .....  | \$18,905,000" |



## TRADING TIMBER FOR LOGGED-OFF LAND

---

Exchange of merchantable stumpage in United States National Forests for adjacent logged-off lands is a new policy which is being pursued by the Forest Service. A dozen such exchanges have been made in the United States, of which four have been in Oregon.

The policy, which is still in process of formulation, adds to National Forest area land which has been logged and which has little or no agricultural value, but which, if given proper conditions, will produce a new crop of trees. The benefit of bringing the area under government reservation and care, while the private owner is compensated by new stumpage for his mill, is largely in affording the logged-off area better protection from fire.

No general congressional action has sanctioned the policy. For each transaction or group of transactions the Forest Service has been compelled to get a special bill through Congress. Passage of these bills has been obtained with little difficulty, but the memory of the old "lieu land" situation will make difficult any general authorization for exchanges of tim-

ber and land, on any basis. Forest Service men, nevertheless, hope that such congressional action may be procured within a few years.

The exchanges are made on a basis of market value for the stumpage and appraised market value for the logged-off lands. The appraisal is made by Forest Service engineers.

Communications received by the Swayne Lumber Co., Oroville, Calif., and other timber concerns in the Feather River district of California, indicate that the Forest Service is anxious to apply the new policy there.

Although some sugar pine trees now being milled show they are 300 years old, timbermen state that approximately only a century is necessary to bring newly forested areas to marketable bearing again.

The Government has a huge timber acreage in the Pacific Coast states which is mature and ready for market. The new policy of exchange will mean that this will be milled and that additional areas, suitable only for reforestation and not for agriculture, will be added to the acreage of timber growing for the benefit of the future citizens of the United States.

## INSECTS AND FUNGI DAMAGE MORE THAN FIRES

---

*J. M. Swaine, Entomologist, Ottawa.*

---

We are beginning to realize at last that our Canadian forests are disappearing very rapidly, but very few, even among those of us familiar with our woods appreciate how fast this process has actually become. Fires, insects and fungi are the greatest enemies we have to deal with. The fire problem is rapidly being solved. The Forest Protection Associations of the provinces are demonstrating how successfully co-operative measures can deal with such problems. The injuries by insects and fungi, on the other hand, have, until, recently, been practically unrecognized. The actual conditions, however, indicate that these injuries are annually much greater in our forests than that caused by fires. We have a most disheartening example of combined

insect and fungous destruction sweeping through the balsam forests of Eastern Canada at the present time. Upon hundreds of square miles of forest the balsam has been very seriously injured or killed within the last eight years, and on large areas of this practically all the balsam is already dead. The injury appears to be spreading rapidly in the balsam and a similar trouble is affecting the spruce in a much smaller degree. How far this is to spread we do not know, but certainly all balsam in infested forests is threatened with destruction. This subject is of the utmost importance to the lumbermen and provincial authorities of Eastern Canada and should receive immediate and very serious consideration.

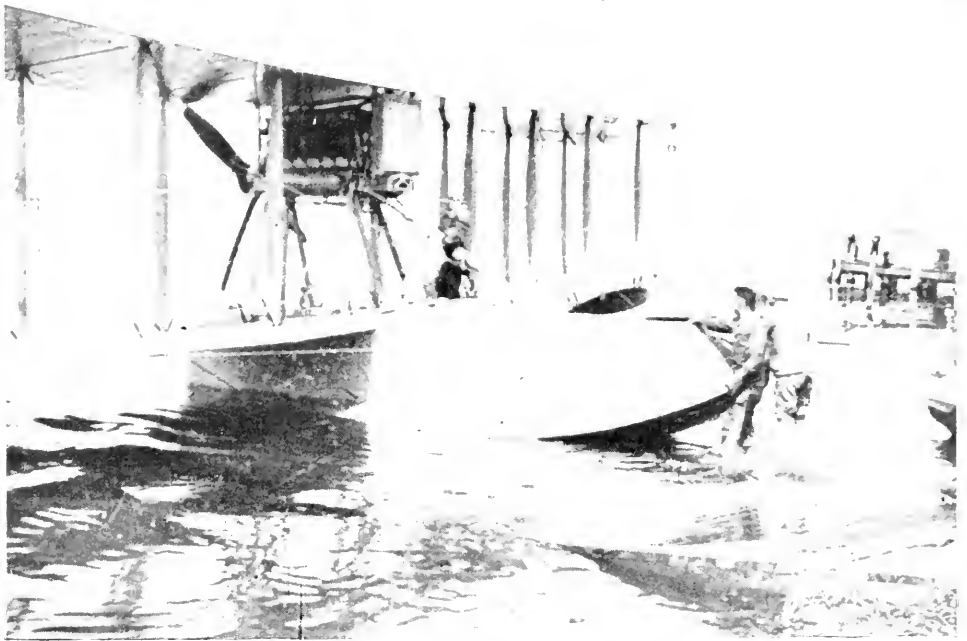

## CANADA STARTS AERIAL FOREST PATROL

### First Experiments Will be Conducted in Central Quebec With Hydro- Aeroplanes.

There is every possibility that Canada will enjoy the distinction of being the first nation to institute an aerial forest patrol. By permission of Hon. C. C. Ballantyne, Minister of Marine and Fisheries and Naval Affairs, two hydro-aeroplanes have been released to the St. Maurice Forest Protective Association for use in Central Quebec. At the date of going to press the Association's pilots were at Halifax preparing to bring the machines to Three Rivers.

The release of the hydro-aeroplanes for forest patrol experiments was obtained only after great difficulty. The original application of the St. Maurice Association, supported by the Quebec Government, was favorably received by Hon. A. K. Maclean, acting in Mr. Ballantyne's absence, and later nullified by Mr. Ballantyne, the latter's decision being again modified after a meeting of a deputation of the Canadian Forestry Association and the Aerial

League of Canada. The part played by the St. Maurice Forest Protective Association in negotiations is worthy of high praise inasmuch as this body volunteered to pay practically the entire expense of maintenance of machines, salaries of pilots and other items of heavy expense so as to secure not only for the St. Maurice region, but for all the Government departments and other private associations in the Dominion, the data absolutely necessary before any system of air patrol can be entered upon. Most observers of the negotiations will doubtless conclude that the Dominion Government has made a remarkably good bargain for the reason that several of the Dominion Government departments have already applied for the use of hydro-aeroplanes for forest patrol and will now be able to avail themselves of the experimental results in the St. Maurice territory. The first pilot to inaugurate the patrols

will be Mr. Stuart Graham, who participated as an airman in the British Government's fight against German submarines. Mr. Graham will have the fullest co-operation of the officials of the Royal Canadian Naval Air Service. Experimental work will be conducted in the use of wireless telephones and telegraphs. It is intended also to try out the use of aerial cameras in mapping forests. The possibilities of this work are most promising.

The flying boat type has been regarded as being most applicable to the conditions accompanying forest patrol in the province of Quebec where lakes and rivers are almost always within reach as convenient landing stations or in case of accidents. From the point of view of the Canadian Forestry Association, the confidence expressed by returned aviators in the efficacy of aerial patrol of forest areas and the ease of forest mapping called for immediate experimental trials. No one having to do with the securing of the Dominion-owned machines for use in Central Quebec has the temerity to advocate aerial patrol as a cure-all for forest fires nor anything but a probably useful auxiliary to present means of fire detection. Recently the Government of Ontario requested from the officials of Argyll House, London, an estimate of the cost of a system of aeroplanes for use in the forested districts of Northern Ontario. Instead of mapping out a modest experimental plan, the officials of Argyll House concocted an elaborate and highly expensive scheme whereby the Government of Ontario might easily be called upon to pay out close to one million dollars during the first year. Quite properly the Ontario Department of Lands and Forests rejected the scheme implying thereby no adverse opinion of possible advantages of aerial patrol for Ontario. The Quebec experiments will probably determine to a material degree the adoption of aeroplanes by Ontario and other provinces in 1920.

The United States Government has recently brought about a co-operative plan between the military authorities of the United States Forest Service whereby government machines will be tested in fire detection work during the present year.

### THE EAST AND EXPORT.

I am strongly of the opinion that Ontario, Quebec and Nova Scotia have not a very large



The flying boat at Halifax Harbor.

quantity of timber that Canada can afford to export. The most of the lumber that is still left in these provinces, in my opinion, will be required for use at home. There is no doubt that a large amount of building will take place during the next few years and these provinces combined will produce very little more than what is required at home. British Columbia, no doubt, has a lot of good lumber and timber and is wanting a market and may be able to export a considerable quantity, but there is at present a large quantity of British Columbia lumber used in the provinces of Ontario and Quebec and the trade in British Columbia and these provinces is increasing monthly. There is not a furniture factory in the provinces of Quebec and Ontario but what are importing large quantities of oak lumber from the United States; also quantities of gum wood are imported. This is all manufactured into furniture. The building trades are importing large quantities of Georgia pine which is used for the construction of buildings; also large quantities of California white pine are imported for the sash and door mills. If we had a large surplus of lumber in the province of Ontario such as many people speak of, we would not have to import such large quantities as we do. — R. E. Truax, M.P. (Walkerton Wholesale Sash & Door Factory, Walkerton, Ont.

## DO YOU KNOW WHERE THESE MEN ARE?

Following are some of the names and addresses of Forestry Association members whose mail has been returned by the post office marked "Not at address". Registered letters also have failed to find them.

Readers of the Journal will confer a great favor by letting the Secretary (206 Booth Building, Ottawa) know the whereabouts of any of these men, should such information be available. The Association's experience shows that many men leave no postal address for forwarded mail, although they have no intention to separate themselves from the membership.

- William Allan, Esq.,  
c/o McLaren Lumber Co.,  
Blairmore, Alta.
- P. C. Bernard-Harvey, Esq.,  
Post Office Building,  
Edmonton, Alta.
- J. H. Billingslea, Esq.,  
University, Lewis Hall,  
Seattle, Wash., U.S.A.
- W. E. Bailey, Esq.,  
10 The Salisbury,  
297 St. Antoine St.,  
Montreal, Que.
- G. W. Bowles, Esq.,  
148 Glendale Ave.,  
Toronto, Ont.
- J. A. R. Bedard, Esq.,  
Marion P.O., Que.
- Edward S. Bryant, Esq.,  
38 Asticon Road,  
Forest Hills Station,  
Boston, Mass., U.S.A.
- Albert Bowset, Esq.,  
Lr. Fairfield Rd., N.B.
- Geo. A. Bajoie, Esq.,  
c/o Hudson Bay Co.,  
Winnipeg, Man.
- Walter Blois, Esq.,  
34 Lansdowne Ave.,  
Toronto, Ont.
- E. Currie, Esq.,  
1820 East Second St.,  
Long Beach, Calif.
- E. E. Carver, Esq.,  
13th Street South,  
Lethbridge, Alta.
- Can. Pulpwood Producers Ass'n,  
Dandurand Building,  
Montreal, Que.
- Dr. C. F. Dowman,  
1769 45th Street E.,  
Vancouver, B.C.
- John W. Dodds, Esq.,  
678 Ossington Ave.,  
Toronto, Ont.
- J. P. Drewett, Esq.,  
Dept. Railways and Canals,  
Ottawa, Ont.
- R. R. Day, Esq.,  
Grand Mere, P.Q.
- J. A. Echlin, Esq.,  
504 Queen Street E.,  
Toronto, Ont.
- R. W. Evoy, Esq.,  
Kinuso, Alta.
- J. L. Farwell, Esq.,  
35 Richmond St. W.,  
Toronto, Ont.
- Capt. J. Fraser,  
Br. Can. Rec. Missions,  
901 Main St.,  
Kansas City, Mo., U.S.A.
- Thos. Flynn, Esq.,  
Board of Trade Building,  
Montreal, Que.
- H. Gale, Esq.,  
Vancouver, B.C.
- H. H. Greenamyre, Esq.,  
11142 91st St.,  
Edmonton, Alta.
- L. C. Godbout, I.F.,  
Mont Laurier, P.Q.
- Richard Hibbard, Esq.,  
Boynton, Ont.
- E. Hellman, Esq.,  
606 Bank of Ottawa Building,  
Vancouver, B.C.
- C. J. Haddon, Esq.,  
B. C. Forest Service,  
Kamloops, B.C.
- J. C. W. Irwin, Esq.,  
143 Grenadier Rd.,  
Toronto, Ont.
- David James, Esq.,  
Fort Fraser, B.C.
- Philip Loosemore, Esq.,  
35 Woodlawn Ave.,  
Toronto, Ont.
- Thos. T. Lawson, Esq.,  
5380 Sherbrooke St. W.,  
Montreal, Que.
- David McTierman, Esq.,  
Eryson, Que.
- Thomas MacLaughlin, Esq.,  
Pembroke, Carleton Co.,  
N.B.
- A. J. Moyers, Esq.,  
Dept. Railways and Canals,  
Ottawa, Ont.
- A. E. Might, Esq.,  
Camrose, Alta.
- John C. Moyan, Esq.,  
Cercal Dept.,  
Macdonald College, Que.
- E. C. Manning, Esq.,  
P.O. Box 1253,  
Calgary, Alta.
- J. E. McTellan, Esq.,  
Moose Jaw, Sask.
- B. C. D. Phillips, Esq.,  
303 Winch Bldg.,  
Vancouver, B.C.
- Fred B. Robinson, Esq.,  
155 Yonge St.,  
Toronto, Ont.
- Charles T. Rutty, Esq.,  
Calgary, Alta.
- P. W. Richards, Esq.,  
P.O. Box 20,  
Indian Head, Sask.
- Wm. Stanley, Esq.,  
2317 Main St.,  
Vancouver, B.C.
- R. W. Street, Esq.,  
3395 Lanoraie Ave.,  
Montreal, Que.
- S. H. Sykes, Esq.,  
718 Metropolitan Bldg.,  
Vancouver, B.C.
- John G. Savage, Esq.,  
405 MacKay St.,  
Montreal, Que.
- Wm. Seip, Esq.,  
Powell River, B.C.
- Ralph M. Taylor, Esq.,  
L'Annonciation, Que.
- J. Ellis Taylor, Esq.,  
301 University Ave.,  
Montreal, Que.
- J. P. Turner, Esq.,  
McArthur Block,  
Winnipeg, Man.
- Walter D. Wilcox, Esq.,  
El Tovar, Grand Canyon,  
Arizona, U.S.A.
- Henri R. Wickenden, Esq.,  
303 Winch Building,  
Vancouver, B.C.
- G. C. H. West, Esq.,  
Chapleau, Ont.
- H. H. White, Esq.,  
39 Highview Crescent,  
Toronto, Ont.
- Albert M. Woodman, Esq.,  
Delora, Ont.
- H. N. White, Esq.,  
1212 5th Street W.,  
Calgary, Alta.
- F. H. Whitney, Esq.,  
1726 32nd Avenue W.,  
Calgary, Alta.

## PLANES AS SCOUTS IN BIG CONFLAGRATIONS

In view of the United States Forest Service, aircraft would be useful not only in the discovery of fires at their origin, but also in scouting large fires while in progress, as in the case of the great Minnesota disaster, thus minimizing the material destruction and the loss of life. The experience of forest officers in fighting fires in the National Forests if the Western States has emphasized the importance of having an efficient scouting service on every large fire. Where a fire is confined to one watershed its progress can usually be determined from some high point. But often a fire may be burning in several canyons at the same time. The general topography of the country, but more especially the depth and width of the canyons, may influence wind conditions to such an extent that a fire in one canyon may be headed in one direction, while in the next canyon the fire will be burning in the opposite direction.

If the fire covers a fairly large area—for instance, ten or more square miles of a rough mountainous country containing no inhabitants and practically no transportation system, and where timber and underbrush are so thick that trails must be cut before a pack outfit can reach a suitable site with a camp outfit for the fire fighters—the difficulties encountered by a fire scout are readily realized. In much of the western country it is difficult to travel on foot more than a mile an hour, owing to steep slopes and thick underbrush. The use of aircraft for scouting purposes under such conditions should prove most efficacious.

The idea of utilizing airplanes in this kind of work is not, of course, altogether new. Aircraft were successfully used in directing the forces engaged in fighting the big fire in munition warehouses in New Jersey some months ago.

It is probably premature to discuss the value of aircraft in actual forest fire suppression work. Some types of aircraft would lend themselves to the transportation of fire fighters. The suggestion has also been made that bombing planes could be used to advantage in that fire-proof bombs, consisting of certain chemicals, could be hurled on fires in sufficient quantities to extinguish them. How practicable a scheme of this kind might be remains to be seen. It goes without saying, however, that the adoption

of aircraft for patrolling the forested areas of the country will create a large field for experiments of many kinds.

### "CONTRIBUTING MEMBERS".

The following are new "contributing members" of the Canadian Forestry Association, supplementing the list hitherto published:

|   |                         |
|---|-------------------------|
| C. Mickle                               | John G. Turnbull        |
| D. L. White, Jr.                        | E. Thomas               |
| R. Southam                              | Gill & Fortune          |
| Mrs. H. D. Warren                       | Sigmund Samuel          |
| Fred M. Tennant                         | T. Walklate             |
| The Soper Lumber Co.                    | Shives Lumber Co.       |
| McAuliffe-Davis Lumber Co.              | R. W. Reford            |
|   | George Creak            |
| Western Retail Lumbermen's Association. | H. L. Putnam            |
| Merkley Bros., Ltd.                     | Estate of Geo. H. Eaton |
| Frank J. D. Barnjum                     | A. Joly de Lotbiniere   |
| John Fenderson & Co.                    | Francis W. Caulfeild    |
|   | A. C. MacIndoe.         |

### WHERE B. C. WOOD GOES.

The United Kingdom was the biggest purchaser of British Columbia lumber during 1918, the next best customers being Japan, China, Australia, Africa, South Sea Islands, and South America, in the order named.

Douglas fir leads all other woods in the total cut for 1918, with cedar second, spruce third and hemlock fourth.

The 1918 pulp production showed sulphite 66,054 tons, sulphate 12,188 tons, and ground wood 91,145 tons.

### BRITAIN REFORESTING.

Two hundred thousand acres of forest land in Great Britain are to be replanted, at a cost for planting and maintenance the first ten years, of \$17,000,000, according to an announcement by the Government. The trees will replace some of the heavy timber cut down during the war, and provide additional forests so that the country may be independent of other timber sources in case of emergency.

# DANGERS OF THE LOCOMOTIVE SPARK

(*Railway and Locomotive Engineering.*)

We have observed in connection with some of the large railroads of the country that severe service tests have been given through a period of years to develop better conditions and that the front-end arrangement on locomotives, or what is known as the "spark arresters", have been receiving careful consideration. It is a question to draw forcefully the attention of this subject to every official, as we consider the spark hazard is possibly the greatest that has to be contended with in connection with fires on railroad property and that even though spark causes have been very much lessened in many instances, it is a question whether it may not be possible in the future to eliminate entirely the occurrence of fires from these causes. . . . We find that the relative importance of the value of property destroyed shows that sparks from locomotives occupies about second place of all the sundry hazards involved in the destruction of railroad property, and that in the number of fires reported it occupies about the same relative position. . . .

a locomotive, but that of a flying brand from the original spark fire within the above distance. These conditions, however, would not prevail with a defective spark-arrester. So small is the heat-carrying power of a spark from a locomotive in good condition that there is doubt as to whether or not they cause a fire. Well-known laws applied to falling bodies show that sparks sufficiently large to carry fire must, under ordinary conditions of discharge and of wind velocity, strike the ground within a comparatively short distance from the track.

There is, therefore, nothing to bear up the locomotive spark but the initial velocity with which it is projected. From considerations, it should be evident that conclusions based on observation in connection with fixed fires are not applicable to the conditions affecting sparks in locomotive service.

We believe with a uniformity in respect to careful maintenance of the corrective influences that have been devised up to date, that much can be done in preventing the large fire waste caused by flying sparks. This, however, must receive careful individual co-operation on the part of all employees and the motive-power departments, and our hope is that we may be able in the future to acknowledge the result of the work of some inventive mind that will bring about the entire elimination of fires caused by sparks thrown from the smoke-stacks of locomotives.

The approximate danger-line from sparks is 150 feet distance from the centre of the track. In confirming this statement the testimony of those who have had occasion to observe the progress of fires originating from locomotives is to the effect that while objects located at a greater distance sometimes burn, the firing of such objects is not the immediate result of sparks from

## 1918 FOREST FIRES IN NEW BRUNSWICK AND NEEDLESS DAMAGE CAUSED

| CAUSES   | No. of fires. | Area, acres. | Damage.  |
|--|---------------|--------------|----------|
| 1. Fishermen, hunters, campers, picnic parties, neglecting camp fires or throwing away burning matches -----     | 29            | 17,874       | \$55,817 |
| 2. Settlers neglecting their slash fires-----  | 15            | 185          | 8,950    |
| 3. Careless use of fire by industrial operations, such as portable mills, rossing plants, etc.-----              | 5             | 62           | 2,743    |
| 4. Fires caused by railroads, defective nestings and ashpans—hot clinkers being thrown on right of way, etc----- | 788           | 637          | 2,606    |
| 5. Unknown causes -----  | 10            | 318          | 2,150    |
| 6. Incendiary (supposed) -----   | 3             | 4            | ----     |
| Totals -----   | 850           | 19,080       | \$72,266 |

## SWEDEN VERSUS CANADA—A FIGHT FOR BRITISH MARKETS

Speaking at a lumbermen's meeting in Toronto, Mr. Montague Meyer, who is accompanying Sir James Ball, British Timber Controller, in his tour of Canada, outlined the purchases that had been made in Canada this year. In the Ottawa Valley they had bought 50,000 standards of white pine and red pine. They had also purchased the majority of the wintered stocks of spruce from Ottawa right down the St. Lawrence and practically all of the wintered stocks and some of the fresh cut stocks in the Bay of Fundy and New Brunswick. He said that attention must be paid to the requirements of the European markets for special sizes and grades of spruce if they wished to secure the trade that formerly went to Sweden. "We have no wish to spend a single shilling in Sweden", he said, "if we can help it. At the present time we can not help it, but the time will come when Canadian lumbermen, if they do the right thing in regard to manufacturing what the market wants, will furnish us with the majority of our

timber and only a small portion of our imports will come from Sweden."

### THE REST OF THE STORY.

Mr. Meyer might have continued his remarks to include a parallel between the development of forestry practice in Sweden and the absence of any such exotic in the Dominion of Canada. Mr. Meyer stopped at the mill-gate. He might have told, with much advantage, how that in Sweden the entire forest area, in public and private ownership, is virtually under a reign of scientific forestry law, that little or no cutting can be done anywhere unless in agreement with forestry regulations. Sweden employs more than four hundred professional foresters as the dictators of cutting practice, with the result that Sweden to a very large extent is taking out only the increment and leaving her forest capital intact. This is not true of any part of Canada east of the Rockies except in local patches.—Editor Canadian Forestry Journal.

FOR BIGGER  
AND BETTER CROPS  
**STEELE, BRIGGS'**  
**SEEDS**  
SOLD EVERYWHERE IN CANADA  
WRITE FOR NEW CATALOG  
**STEELE, BRIGGS SEED CO.**  
"CANADA'S GREATEST SEED HOUSE" LIMITED  
**TORONTO**  
HAMILTON WINNIPEG

## IS THIS BORROWED MONEY OR REVENUE ?

(A Statement by Dr. C. D. Howe, before Toronto Board of Trade.)

"Our so-called forest revenues are not revenues at all. They represent so much money taken from the capital stock; an average of 1.5 million dollars in Ontario for the past ten years, and nearly the same for the province of Quebec. It is not revenue at all; it is borrowed money. You are already paying exorbitant interest on it in the steadily rising pulpwood and lumber prices, and you will pay a higher rate each year so long as the practice of borrowing is continued. Also, because we are each year reducing our forest capital and so restricting its production you contribute in the aggregate large sums of money to pay the wages of lumbermen in the States instead of paying our own lumber-

men. You do this every time you buy southern pine to furnish your house, and practically every house I have entered in my ten years residence in Toronto contains more or less southern pine.

"This borrowed capital must be restored to the forest either in the form of planting or in the form of regulated logging operations—probably both, if our lumbering and pulpwood industries are continuously to be maintained even at their present capacities. Either method of restoration will be very costly, but you or your children because of your previous neglect will be compelled to pay the price. The longer you wait, the higher the price."

## WINNING THE PEOPLE FOR FOREST PROTECTION

The Canadian Forestry Association is now busily engaged carrying out an extensive programme in rousing the public to active co-operation in forest protection.

Our newspaper publicity bureau has had uncommonly hearty aid from the editors of English and French newspapers in all parts of Canada. Articles and editorials on forest protection and reforestation are appearing without stint and at a season of the year when interest in the subject is most productive of benefit.

Lectures, with motion picture illustrations, have been given by Mr. Robson Black before many audiences in Ontario and Quebec, two large and influential gatherings being arranged during April under the auspices of the Royal Canadian Institute at Toronto University, and the Canadian Club of Kingston, Ont.

Our Railway Demonstration Car, is now being outfitted on a scale much more extensive than applied to last year's car, and will make a tour of scores of communities in Eastern Canada, motion picture lectures being given in local halls each evening.

The Association now possesses two complete motion picture projectors and ten reels of picture film, the latter being used for circulation in regular theatres where opportunity offers.

Mr. A. H. Beaubien, who conducted many successful French lectures for the Canadian Forestry Association last year, will start during the last week of May for Quebec points to hold a series of public meetings to stimulate public

interest in fire protection. Mr. Beaubien this year will have the aid of excellent motion pictures.

Meetings will be organized by the Association in Northern Ontario early in June and a series of illustrated talks given. The usual audience in Northern Ontario for Forestry Association meetings averages above three hundred persons.

As was done last year, hundreds of brief and pointed cartoons and fire warnings, in the form of lantern slides, are being sent to the motion picture theatres in forested districts for use between the reels of film. This is a potent means of reaching large numbers of people.

New forms of educational literature have been issued and carefully distributed to Canadian schools, as follows:

19,000 to New Brunswick.  
5,000 to Nova Scotia.  
2,000 to British Columbia.  
15,000 to Ontario.  
35,000 to Quebec.

2,500 special pieces of school reading to school teachers of the Western Provinces.

The foregoing publications are being supplemented from month to month by other novel reading matter, arranged in such form as to gain sure attention.

In New Brunswick, Quebec and Ontario, Quebec and Ontario, many of the rangers are visiting the schools personally and reading interesting stories supplied by the Forestry Association, to the classes of children.





## FOREST TELEPHONES

Make the life of the forester better worth living. They relieve him from the appalling loneliness. They help him to keep in human voice touch with foresters miles away.

In emergencies—fire—sickness—hunger—the speed with which they can summon help is marvellous.

Write for full particulars of how to install the Northern Electric Forest Telephone System. Address the Office nearest you.

*Northern Electric Company*  
LIMITED

|          |          |           |
|----------|----------|-----------|
| Montreal | Toronto  | Regina    |
| Halifax  | London   | Calgary   |
| Ottawa   | Winnipeg | Vancouver |

***Northern Electric Forest Telephones***

## BRITISH COLUMBIA'S TIMBER WEALTH

### Enormous Stands Available, but Forest Fires Have Taken 665 Billion Feet

The recently published report of the Commission of Conservation on the forests of British Columbia by Roland D. Craig, F.E., and H. N. Whitford, Ph.D., is a comprehensive work, well illustrated with maps and photographs. Through the co-operation of the Provincial and Dominion Governments, the timber owners, the Canadian Pacific railway and other interests, the authors secured very complete data on which to base the estimates. The province was divided into 66 districts, for which separate estimates of the stand were compiled.

The forest resources of the province are estimated to be approximately 350 billion feet saw-material with an additional 16 billion feet suitable only for pulp. In addition to the estimate

of the stand, the report describes the effects of the climate, soil and topography on the forests, and outlines the various systems of tenure under which the forest resources have been alienated. Interesting chapters are devoted to the description and distribution of the various species of trees and to the injuries done by insects.

The total land area of the province is 355,855 square miles, of which approximately 200,000 square miles is incapable of producing forests of commercial value. About 145,000 square miles lie above the merchantable timber-line, and on 55,000 square miles below the timber-line the soil is either so rocky or wet, or the forests have been so completely destroyed by fire that there is no hope of natural re-establishment of forest conditions for centuries.

Of the remaining 155,855 square miles, which is capable of producing forests, only about 28,000 square miles—less than one-fifth—carries sufficient timber to be classified as statutory timberland. In the interior of the province, there are areas of forest land, aggregating 23,800 square miles, which, though not reaching this standard, carry between 1,000 b.f. and 5,000 b.f. per acre, part of which may be utilized. Only very meagre data have been obtained, as yet, as to the area of land which can be used for agricultural purposes. The forest land classification indicates that somewhat over 5,000 square miles is grass land or very open forest, some of which is suitable for cultivation, but the greater proportion is of value only for grazing. In addition, there is, perhaps, from 12,000 to 15,000 square miles, cleared or under forest, which is more valuable for agriculture than for forest production. Deducting this potential agricultural land, say 20,000 square miles, from the total capable of producing commercial timber, there is 135,855 square miles of absolute forest land which should be devoted permanently to forest production.

The timber on about 100,000 square miles, or two-thirds of the original forest land, has been totally destroyed by fire, and on over half of the remaining 55,855 square miles the timber has been seriously damaged. It is estimated that the province has lost, through forest fires, at least 655 billion feet board measure. As the present total stand of saw material in the whole Dominion probably does not greatly exceed this amount, the seriousness of this loss, due very largely to public carelessness, is apparent.

The following table indicates the composition of the present stand of saw material:

Of the species used in the manufacture of pulp and paper (hemlock, balsam, spruce and cottonwood), there is 170 billion feet, which is equivalent to 243 million cords of pulpwood. This may be increased to 250 million cords by utilizing smaller timber. As the supply of pulpwood is becoming a very serious matter in eastern North America, it is important to know that so considerable a supply may be obtained in British Columbia.

During the last five years the total cut in the province has averaged only 1,250 million board feet. With a stand of 350,000 million board feet of timber of commercial size, and with over 100,000 square miles of land on which young forests are established and which, if protected, should produce from 5,000 million to 7,000 million board feet per annum, it will be seen that the forest resources of British Columbia can, under conservative exploitation, supply at least five times the present cut without seriously depleting the capital stock.

MR. AND MRS. CAMPER

WHEN you leave your camp,  
please see that you leave  
no sign of fire behind!

Big forest fires  
are just grown-up campfires!

| Species.            | COAST                           |             | INTERIOR                       |             | TOTAL                          |             |
|---------------------|---------------------------------|-------------|--------------------------------|-------------|--------------------------------|-------------|
|                     | Million<br>bd. measure.<br>feet | Per<br>cent | Million<br>feet<br>bd. measure | Per<br>cent | Million<br>feet<br>bd. measure | Per<br>cent |
| Western red cedar   | 59,000                          | 27.4        | 18,019                         | 13.2        | 77,019                         | 22.1        |
| Douglas fir         | 64,000                          | 29.4        | 12,573                         | 9.2         | 76,573                         | 21.8        |
| Spruce*             | 14,000                          | 6.7         | 58,375                         | 42.8        | 72,375                         | 20.6        |
| Western hemlock     | 52,000                          | 24.6        | 12,164                         | 8.9         | 64,164                         | 18.3        |
| Balsam†             | 19,000                          | 9.2         | 13,838                         | 10.2        | 32,838                         | 9.5         |
| Lodgepole pine      | 20                              | .1          | 12,130                         | 8.9         | 12,150                         | 3.5         |
| Western yellow pine | ---                             | ---         | 4,208                          | 3.1         | 4,208                          | 1.2         |
| Yellow cypress      | 3,700                           | 1.9         | ---                            | ---         | 3,700                          | 1.1         |
| Western larch       | ---                             | ---         | 3,152                          | 2.3         | 3,152                          | .9          |
| White pine          | 1,100                           | .5          | 1,617                          | 1.2         | 2,717                          | .8          |
| Black Cottonwood    | 400                             | .2          | 272                            | .2          | 672                            | .2          |
|                     | 213,220                         | 100.0       | 136,348                        | 100.0       | 349,568                        | 100.0       |

\*Includes Sitka spruce, Engelmann spruce, white spruce and black spruce.  
†Includes alpine fir, lowland fir and amabilis fir.

Peterborough Canvas Covered and Wooden Canoes are built in all sizes and for all purposes. For Pleasure, Cruising, Trapping or Freighting.



Peterborough Motor Boats, like the Canoes, are built in all sizes and for all purposes. If you are interested we will send you our illustrated Catalogue.

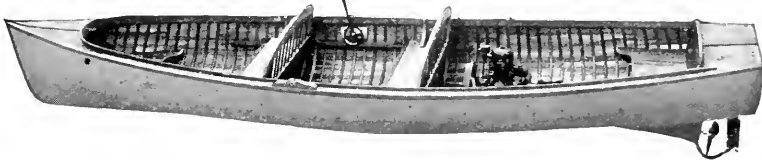

This Trade Mark appears on all genuine Peterborough Craft.

THE PETERBOROUGH CANOE CO. LIMITED  
Peterborough, Ontario, Canada

# FORESTERS!

We want you to know  
all about our

“ARCTIC EIDERDOWN  
SLEEPING ROBES”

It is to your own personal interest and  
comfort to own an Arctic Robe.

—Manufactured only by—

WOODS MFG. CO. LIMITED  
OTTAWA



“Booklets Ready for Mailing.”

## BENEFICIAL EFFECTS OF FOREST COVER

By *Samuel T. Dana.*

Perhaps the most obvious relation that exists between forests and water is the tendency of the tree cover to check erosion. The leaves and branches of the trees prevent the rain from beating upon the soil as it does in the open; the cover which they afford delays the melting of snow in the spring; the upper layers of the forest soil act as an enormous sponge that absorbs large quantities of water which in turn are passed on to the great reservoir of mineral soil underneath; and finally the surface cover of stumps, fallen twigs, branches, and even whole trees acts as a mechanical obstruction to prevent rapid run-off. The surface run-off from forest areas is less, both in total amount and in

velocity, than that from similarly situated un-forested areas. The steeper and more rugged the topography, the more marked is this contrast.

In hilly country some erosion is, of course, inevitable under any conditions. When the soil cover of trees, underbrush, and litter is kept intact, however, this is more often beneficial than otherwise, since only the lighter soil particles are washed away, to be later deposited in the more level lands below, adding to their fertility. But when this protective cover is interfered with, whether by fire, destructive lumbering, overgrazing, or injudicious clearing of land for agriculture, the proportion

### WESTERN AUSTRALIAN PUBLIC SERVICE PERMANENT POSITIONS UNDER THE PUBLIC SERVICE ACT.

Applications will be received until May 31, 1919, for the position of Working Plans Officer in the State Forestry Department.

Salary, £504-£636.

Applicants must be qualified foresters having a degree or diploma of a forest school.

G. W. SIMPSON,  
Public Service Commissioner.

Perth, Western Australia.

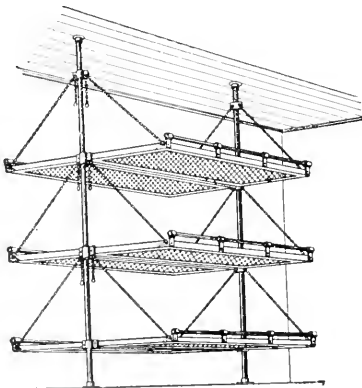

### STEEL BUNKS FOR CAMPS

Included in the well-known line of DENNISTEEL factory, hospital, camp and ship equipment is the all-steel sanitary bunk illustrated. Take up very little room, are comfortable, hygienic and practically indestructible—a permanent investment. Write for particulars and folders on any of the following lines: Steel Lockers, Bins, Cabinets, Chairs, Stools, Etc. Standardized Steel Shelving (knock-down system), Steel Hospital Equipment, General Builders' Iron-work, Ornamental Bronze, Iron and Wirework. Wirework of every description.

THE DENNIS WIRE AND IRON  
WORKS CO. LIMITED

LONDON  
CANADA

HALIFAX MONTREAL OTTAWA TORONTO  
WINNIPEG VANCOUVER

of coarser, infertile materials washed away increases greatly and transforms erosion from a constructive into a dangerously destructive force, difficult of control and capable of doing untold damage.

#### As Water Users See It.

From the standpoint of the water user, the tendency of the mountain forests to prevent erosion is of the utmost importance. Wherever storage reservoirs must be used, whether for municipal supplies, irrigation, or water power, they are exposed to the ever-present danger of silting up. Every bit of soil brought down by the streams and deposited in them reduces their capacity and consequently their effectiveness by just so much. This sedimentation is serious under any condition, but doubly so when, as not infrequently happens, no other satisfactory dam sites are available and the reservoir can not be replaced at a reasonable cost.

Water heavily laden with eroded material often decreases the efficiency and increases the cost of maintaining diversion dams, pipe lines, flumes, canals, and other irrigation works. Sometimes such water damages the crops to which it is applied, and not infrequently it seriously injures or even ruins the land by burying it under a mass of sand, gravel, boulders, and other infertile debris. Excessive erosion may interfere seriously with navigation by filling the streams with material which is deposited in their lower reaches and in the harbors into which they empty.

#### Even-Flowing Streams.

The action of the forest in reducing surface run-off tends also to regulate the flow of streams. Instead of rushing away in uncontrollable torrents the water is absorbed into the great reservoir of mineral soil, from which it is gradually paid out to the springs and streams. This tends to decrease the high water run-off and to increase the low water run-off. Both results are good. The decrease in the high water run-off means that there is less danger of destructive floods and less waste of valuable water; while the increase in low water run-off means that a larger supply of water is available during the dry season, when it is particularly needed. It is the low water flow that to a great extent determines the availability of any given supply for municipal use, irrigation, or hydroelectric development, and anything which will increase this flow is therefore a factor of prime importance.

#### SAVE TREES BY USING THEM.

"There is no need of our saving trees through the non-use of wood", say the chiefs of the Forest Service, who are the nurses, sales-agents, and managers of our more than 150,000,000 acres of nationally owned forest lands. They are also consulting physicians to the remaining four-fifths of our forests still under private ownership, and are available as expert advisers to all users of trees or tree-products.

Under certain limitations we have plenty of timber, provided it is conserved intelligently and consumed with sensible economy. But we have been getting less than 50 per cent of the value out of the trees we fell, as against Germany's 98 per cent.

We should conserve not by non-use, but by intelligent use—that is to say, by getting the fullest possible return from every tree. This means more efficient lumbering, better saw-milling, and better wood-working all along the line. It means also the unlimited utilization of waste products. The Nation's Business.

#### THAT EMBARGO ON PULPWOOD.

"With the end of supplies in sight in many United States mills, some of them have turned to Canada. Instead of taking measures to insure a continual growth in their own land they have killed the goose that laid their golden eggs, and have come north in the hope of finding another brood. The fact that the Canada goose has turned out to be somewhat in the nature of an owl and looked with some degree of wisdom and foresight on the situation seems to disturb those who would have raided the nest. Canada has foreseen the danger in time, and intends to have her forest resources continue to contribute to the welfare of future generations of Canadians."—*Can. Pulp & Paper Magazine.*

The Forest Products Laboratories at Madison, developed from "clabber" (casein) taken from fine Wisconsin Jerseys a glue of remarkable adhesiveness. Woodblocks joined with it have held against ten days' soaking supplemented by twenty-four hours' boiling in water. The process is now available without cost of industry and enables any manufacturer of furniture to put together articles that will stand the test of any climate.

**TREES, SHRUBS and SEEDS**

HARDY NORTHERN TREE STOCK

**EDYE-DE-HURST & SON, DENNYHURST**

DRYDEN, ONT.

Shippers to H.M. Government.

**Hill's Seedlings & Transplants**

ALSO Tree Seeds for Reforesting. Best for over half a century. Immense stock of leading hardy sorts at low prices. Write for price list and mention this magazine. Forest Planters Guide Free.

**The D. HILL NURSERY CO.** Evergreen Specialists  
Largest Growers in America.  
Box 503. DUNDEE, Ill., U.S.A.

**Try This Stump Puller at Our Risk**

The Smith Stump Puller will take out every tree and stump by the roots, clearing from one to three acres a day, doing the work of twenty men. We want you to send for our 3 year guarantee against breakage and our free trial proposition. Address W. Smith Grubber Co. 11 Smith St. LaCrescent, Minn.



**GAGNON & MORISSETTE**

TIMBERLAND CRUISERS  
LUMBER CONTRACTORS  
FOREST INDUSTRIES

CHICOUTIMI, - - P.Q.

**LT.-COL. L. J. D. MARQUIS**

Forest Engineer and Mem. Can. Soc. of F.E.; Quebec Assoc. of F.E.; Former Mem. Que. F. Service  
Timber Factors and Logging Costs  
Facts on Forest Growth and Future Products  
Forest Cruising and Mapping  
90 LOCKWELL AVENUE - - QUEBEC

**Timber Lands Bought & Sold**

Timber and Pulp Wood Estimates.

**R. R. BRADLEY**

CONSULTING FORESTER

Globe-Atlantic Bldg. - ST. JOHN. N.B.

ASK



FOR



**Timber Estimating & Mapping**

Management of Forest Properties.  
Supervision of Lumbering Operations.  
Forest Planting.

**COOLIDGE & CARLISLE**

FOREST ENGINEERS

BANGOR - - - - - MAINE.

**Timber Estimates**

JAMES W. SEWALL

Old Town, Maine.

## ONTARIO'S NEXT MOVE.

The earliest recognition that timber land administration involved more than the scaling of timber and collection of dues, came in the form of organization to protect timber from fire. There came into existence in most of the provinces two separate staffs, one charged with protective and the other with administrative duties—the one idle in the winter and the other in the summer. This unbusiness-like arrangement has gradually disappeared in province after province, until now Ontario is the only province in which all the phases of timber land administration are not consolidated under one organization. Quebec was the first province to place the timber administration in technical hands, and to provide technical instruction for its staff. British Columbia followed, and within a year, New Brunswick has reorganized its timber land administration under technical direction.—Dr. B. E. Fernow.

## FUTURE PROFITS.

In the coming years we are destined for an immense export trade in the direct and by-products of our forests. An immediate expansion of our timber preserving activities is, therefore, a matter of supreme necessity. —Belleville Intelligencer.



## SPORTSMEN, PROSPECTORS, SURVEYORS

**Y**OU want a canoe that will stand any strain—easy to handle—light on the portage, yet can carry big loads. Over the rapids is where you test a canoe.

### CHESTNUT CANOES

are built for strength and beauty. They are finely shaped, built of the best and strongest New Brunswick Cedar and covered with a seamless, absolutely waterproof and non-destructible canvas.

The Chestnut Pleasure, Sponson, and Cruiser Canoes are comfortable, roomy, clean, safe and handsomely finished. They are the most suitable craft for the purposes for which they are designed.

**Chestnut Canoe Co. Limited**

Box 460. FREDERICTON, N.B.

## SHOULD FIREWOOD BE SOLD BY WEIGHT, NOT BY CORD ?

The idea is advanced by the United States Forest Service that wood fuel should be sold by weight instead of by cord measure. The ground for this is that the heating value of wood depends not upon the bulk of the fuel but on its solid contents. We all know that firewood can be so piled that it will measure 128 cubic feet, yet if repiled in an honest way the pile will shrink to much less than that.

All persons know that it is the solid content of the wood that produces heat, not the water that may be sealed up in the sap vessels or the air in the crevices. Yet, in buying wood by measure, one must pay as much for these or for the air in the spaces between the sticks as for the solid fuel. It is further laid down

that a pound of dry wood of one species has as much heating value as a pound of any other species, nearly or quite so. A little reflection will convince any one that this is most probably true. While a pound of dry sap wood may have as much heating value as a pound of heart wood it would fill a very much larger space. Of course the Forest Service has not advanced this idea without careful experiment, for it is not the custom of these scientific bodies to promulgate anything which is a mere notion founded on guess.

It would be doubtless inconvenient to weigh wood. But many a change once derided has since become an established system. It is a matter of history that the first man to raise

an umbrella on a rainy day in any civilized country was stoned by the populace, who looked upon the act as impious. The first dealer who arranges to weigh his wood, selling it by the ton or hundredweight, or fraction thereof, as coal is sold, and advertises the fact is likely to draw a great increase to his trade, if it were only for the novelty.

Though the idea of weighing firewood may seem preposterous to many we might as well become prepared for the changes that this rapid age brings about so quickly. Eggs will yet be sold by weight instead of by count, for it is well known that one dozen of large eggs will weight more than another of small ones, and will contain as much more food as the

difference in weight indicates, or even more. Potatoes now are sold by weight in most cities. The tendency is to sell by weight many other things that now are generally sold by measure.

Measure is no just criterion of value. Weight is a certain indication of content. It is more honest, more just. Measure is neither, when the objects sold are many in number and various in size.

It must be conceded that a pound of green wood is of far less heating value than a pound of the seasoned fuel. But no one pays as much now for green wood as he does for dry. That is all a matter of custom or of economic regulation.—Florida Times-Union.

---

## CHOOSE ONLY STURDY TREES AS MEMORIALS

---

(*"Forest Leaves," Pennsylvania.*)

---

Before you plant a tree be sure that it is adapted to your region. Some of our native spruce and also our balsam trees are very beautiful trees in the colder parts of our state, but in most of it they live long enough to become of respectable size and then begin to die. The white birch is also a tree of northern origin which of late years has become remarkable by its short life. It would be almost an insult to the memory of any one to plant a tree of such kind for a memorial.

Then on the other hand we know of white oaks five feet in diameter, and of red oaks as large; and of pin oaks and scarlet oaks almost as large—sturdy, symmetrical, impressive masses of life and beauty. Among the cone bearing evergreen trees is the Norway spruce, which in spite of its foreign origin, is actually likely to be more durable than any of our native evergreen trees. White pines, if planted, should be planted in masses, where in the struggle for light the main trunks will grow strong and tall. If the white pine is planted in the open it sends out long branches which are too weak to bear the weight of snow that falls upon them. Then, too, the white pine weevil and the pine blister rust threaten the pine.

Among the other trees we might suggest as suitable and fairly long lived are the black

walnut, the beech and the sugar maple. The hickory trees have the borer to contend with and often die out in a neighborhood before its pesistent attacks. For the same reason the locust can no longer be regarded as suitable for memorable purposes.

---

### SEED SUPPLY PRECARIOUS.

---

Nursery planting in Canada has been greatly handicapped this year by difficulty in obtaining seed. Scotch pine seed was a failure in Europe last season and red and white pine was a failure in Canada.

---

**F**OREST FIRES drive out population

**A live forest means  
live jobs.**

**Therefore:—Put out your  
campfire, your match,  
your cigarette!**





**FAIRBANKS - MORSE  
FIRE  
FIGHTING PUMP**

These outfits are replacing many men and doing work impossible by any other method.

*Send for Information.*

**THE CANADIAN  
FAIRBANKS-MORSE  
CO., LIMITED**

Offices in  
Every large  
Canadian City.

## CONFEDERATION LIFE ASSOCIATION

### UNCONDITIONAL ACCUMULATION POLICIES

Are liberal up-to-date contracts which guarantee to the insured every benefit consistent with safety.

#### WRITE FOR PARTICULARS

which will gladly be furnished by any representative of the company or the

HEAD OFFICE,  
TORONTO



## QUEEN'S UNIVERSITY

KINGSTON  
ONTARIO

### ARTS MEDICINE EDUCATION APPLIED SCIENCE

Mining, Chemical, Civil, Mechanical and  
Electrical Engineering.

#### HOME STUDY

Arts Course by correspondence. Degree with  
one year's attendance.

#### SUMMER SCHOOL JULY AND AUGUST

#### NAVIGATION SCHOOL DECEMBER TO APRIL

GEO. Y. CHOWN, *Registrar.*

## R. O. SWEEZEY

(B.Sc., M.E.I.C.)

WATER POWERS. TIMBER LANDS.  
FINANCING

164 St. James Street - MONTREAL.

## P. L. BUTTRICK

CONSULTING FORESTER

NEW HAVEN, CONN., U. S. A.

P.O. BOX 607

---

TIMBER ESTIMATES  
UTILIZATION STUDIES  
PLANTING PLANS

---

Landscape and General Forestry Work.  
Eight years experience in practical  
forestry work of all sorts.

## UNIVERSITY OF NEW BRUNSWICK

FREDERICTON, N.B.

### DEPARTMENT OF FORESTRY

Established in 1908.

Best of facilities for definite instruction  
and supervision in Practical Forestry.

Surveying, cruising and construction  
work carried on in our own tract of 3600  
acres, with Forestry Camp in the centre.

Competent men from the School at  
present in demand to take up Forest Sur-  
vey work with the Provincial Crown Land  
Department.

For further information address:

### DEPARTMENT OF FORESTRY

University Calendar furnished on application.

C. C. JONES, *Chancellor.*



*A shelter belt of poplar protecting the fruit trees on a large British Columbia farm.*

### THE NATIONAL FORESTS OF THE U.S.

There is in the National forests of the United States under the control of the Forest Service a total area of 160,193,996 acres. To this must be added those of Alaska, with an acreage of 26,748,850 acres, and of Porto Rica 65,950 acres, giving a total area reserved and controlled by the Forest Service of 187,006,796. Within some of these forests what are known as "National Monuments" are specially dedicated for the preservation of objects of historic or scientific interest. These "National Monuments" have a total area of 1,424,940 acres. Within the forests there are also certain National Game Preserves, and these also are dedicated specially by Acts of Congress for the protection of wild animals. These dedicated areas amount to 2,000,000 acres, the greater part of the area being in Arizona.

### ONE WAY TO START A FIRE.

Here's a simple way to start a fire without matches, flint, steel or sticks: Everyone knows how to start paper burning with a magnifying glass, well, that's just the trick, only use a front lense from your field glass. It will make a very strong glass and the brighter the sun the easier it is to start the fire. After your tinder

## MOTION PICTURE MACHINES

## STEREOPTICONS

We are fully equipped to supply projection apparatus on short notice.

LANTERN SLIDES and  
Motion Picture Film made  
up in twenty hours.

Write for Catalog.

PROJECTION DEPARTMENT  
SUPPLIES COMPANY  
OF CANADA

65 SPARKS STREET,  
OTTAWA, ONT.

begins to smoke a little, blow on it and it will break into a flame very much sooner. You don't have to keep a big fire going all day in camp so as to have it ready to cook on at supper time, just keep a smouldering one and you can start it again very easily by fanning a little.

Almost all hunters nowadays carry field glasses and consider them an essential part of their outfit. They are invaluable for searching out and finding game, but it is well to know of another way in which they can be made to serve a useful purpose.

—————SHADE—————

By Theodosia Garrison.

*The kindest thing God ever made,  
His hand of very healing laid  
Upon a fevered world, is shade.*

*His glorious company of trees  
Throw out their mantles, and on these  
The dust-stained wanderer finds ease.*

*Green temples, closed against the beat  
Of noontime's blinding glare and heat  
Open to any pilgrim's feet.*

*The white road blisters in the sun;  
Now half the weary journey done,  
Enter and rest, O weary one!*

*And feel the dew of dawn still wet  
Beneath thy feet, and so forget  
The burning highway's ache and fret.*

*This is God's hospitality,  
And whoso rests beneath a tree  
Hath cause to thank Him gratefully.*

TABLE OF CONTENTS FOR MAY, 1919.

|   | PAGE |
|---|------|
| Trees Are the Best Memorials.....             | 195  |
| How to Plant Memorial Trees.....              | 196  |
| Homing Pigeons for Reporting Fires.....       | 200  |
| A Business Plan for Western Forests.....      | 203  |
| A Proposed British Empire Forestry Assoc..... | 207  |
| A Land of Forests—Without Forestry.....       | 212  |
| A Better Plan for Selling Public Timber.....  | 217  |
| Sweden versus Canada .....                    | 225  |
| British Columbia's Timber Wealth.....         | 227  |

IF YOU WANT A CHEW  
THAT WILL JUST SUIT

YOU ASK FOR

**STAG**

**CHEWING TOBACCO**

RICH AND SATISFYING.

IT IS ALSO KNOWN TO BE  
"EVER-LASTING-LY GOOD"



## Do You Require More Capital?

For ten years, Royal Securities Corporation has been associated with the development and financing of Canada's most successful pulp and paper enterprises. Among them are:

*Abitibi Power and Paper Company.*  
*Brompton Pulp and Paper Company.*  
*Mattagami Pulp and Paper Company.*  
*Price Bros. and Company.*  
*Riordon Pulp and Paper Company.*  
*Fraser Companies, Limited.*

Do you desire to pay off floating indebtedness; increase your plant capacity; or acquire additional properties? If so, why not let us suggest ways of financing your requirements? Our Engineering and Statistical Departments are at your disposal.

**Royal Securities  
Corporation  
L i m i t e d**

164 St. James St.,  
MONTREAL

58 King St. West,  
TORONTO

# Canadian Forestry Journal

June 1919



FACULTY OF FORESTRY

JUL 8 1919

UNIVERSITY OF TORONTO



THE FIRE HAWK.

# Gillette

## Safety Razor

The Shaving Service for Every Man  
—Everywhere

THE POCKET EDITION  
GILLETTE  
BOUND IN  
SEAL-GRAIN LEATHER

THE NEW  
KIT SET  
No. 20

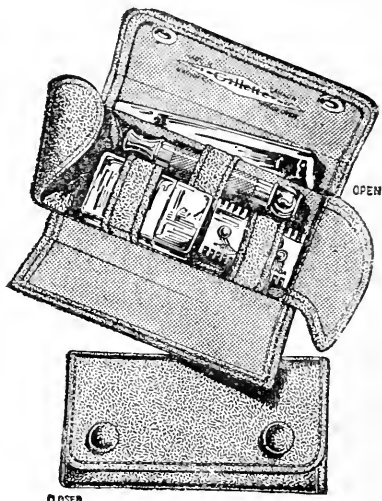

"If I was buying another Gillette Safety Razor," said one enthusiast when he saw the new Kit Set, pictured above, "I would certainly want that one!"

"It not only preserves all the good points of my old morning friend, but it is as compact as any razor set I have ever seen, and takes the least room in the travelling bag.

"And then the black, seal-grain case is so dignified—so appealing to any man who is particular in his appointments. I suppose you are asking a pretty price for that set."

No; merely—

**\$5.00 the set.**

MADE IN

CANADA



KNOWN THE

WORLD OVER

The Gillette Safety Razor Co. of Canada Limited  
Montreal, Canada



# Canadian Forestry Journal

VOL. XV.

OTTAWA, CANADA, JUNE, 1919.

No. 5.



Stuart Graham, aviator, with his wife as navigatrix, and the mechanic, ready for a flight over St Maurice Valley, Quebec.

## THE FIRST FLYING PATROL OF FORESTS

*By Stuart Graham, R. A. F.,*  
in charge of hydro-aeroplane experiments in Central Quebec for  
St. Maurice Forest Protective Association.

### From Halifax to Three Rivers in 9½ Hours Flying Time.--- Dodging Storm Clouds an Hourly Pastime

Leaving the waters of Halifax harbor at 2.25 p.m. with a 10 knot south-east wind blowing, we struck a magnetic course for Cape Blomidon and crossed the North Mountains forty-five minutes later. In the Bay of Fundy the wind changed to a fifteen-mile north-easter which

brought us a heavy fog when ten miles from St. John. We had been flying at an altitude of 1,000 feet, and as the fog gradually forced us downwards we sighted St. John harbor below and landed, making our time in the air two hours and eight minutes for the 145 nautical

miles covered.

Owing to the fog we were obliged to spend the night in St. John.

On the following day the fog had not improved, but knowing it would be clearer inland, we made a start at 12.17 and circled some time to gain altitude. Then taking a north-west course with a twenty-knot head-wind blowing we flew until we reached the International boundary where we altered our course to north. Several times during the afternoon we sighted storms ahead, but in each case we easily circumvented these; until, passing over Eagle Lake, Maine, we encountered a larger storm with low clouds which forced us to land for the night. We had flown for 3 hours and 23 minutes, and covered a distance of 160 nautical miles.

We were then only 38 miles from Lake Temiscouata, where we hoped to obtain a supply of gasoline, so although the clouds were still low and threatening the next day we took the air at 11.40 and arrived at Temiscouata forty-five minutes later. Here our hearts sank for our order of gasoline had not arrived. We had been obliged to fill with second quality gasoline at St. John, but here the only thing obtainable was motor boat gasoline, but we decided to try some anyway as Riviere du Loup was only 35 miles ahead with chances of obtaining some proper gasoline. We got away at 5.5 p.m., and having the wind in our favor reached the coast in thirty minutes.

The St. Lawrence was just recovering from a storm and when we had taken an extra large load of fuel aboard, we were unable to get off the water owing to the cross sea running.

Sunday morning with a strong north-east wind blowing proved excellent weather to continue, so we made our take-off at 1.5, arriving in Three Rivers, 170 miles away, in 2 hours 25 minutes. Here we were met by the president and directors of the St. Maurice Forest Protective Association and the mayor of the city, the Hon. Tessier. The mayoress presented a bouquet to Mrs. Graham, to whose hard work as navigator the success of the flight was greatly due.

Leaving Three Rivers at 7.15, we proceeded up the St. Maurice valley to Lac la Tortue, a twenty-five minute flight, thereby finishing our six hundred and fifty mile (land miles) flight with a flying time of nine hours and a half.

The machine is a Curtiss flying boat, H S2 L, fitted with the famous Liberty 12 cylinder motor which deserves a special word of praise for ab-

solutely no trouble was experienced either with the motor or the plane.

We have a second machine to bring from Halifax, and we will probably leave about June 21st, making the complete trip between sunrise rise and sunset.

---

## ASKED IN PARLIAMENT

### Questions

1. Has the Government received any complaints with regard to the Forest Products Laboratories of the Department of the Interior?
2. Have certain of the leading officials of these laboratories left, and are others about to leave, owing to the fact that wholly inadequate salaries are being paid?
3. Is it the intention of the Government to increase the salaries of trained experts in this Department in order that its value to the lumbermen and paper makers of Canada may be increased?

### Answers

1. Representations have been made that a higher state of salaries should be paid to the technical staff.
2. Certain officials have resigned intimating that better opportunities were offered outside.
3. The matter of salaries is being dealt with by the Civil Service Commission in connection with the reclassification of the Civil Service.

---

## TREES FOR PRAIRIE HOMES.

Since the inauguration of tree distribution by the Forestry Branch of the Department of the Interior, 45,357,146 trees have been distributed for planting on the farms in the prairie districts. All these trees were planted on farms, and 85 per cent of them are growing successfully, but there is room and necessity for as large a distribution for many years yet, according to the report of the Director of Forestry, which is a part of the annual report of the Department of the Interior for the last fiscal year, which has just been issued.

The number of trees distributed to farmers in 1917 was 8,400,000, the largest in the history of this work, and these were distributed to 4,561 applicants. Owing to poor seed conditions in 1916 and an unfavorable year in 1917, the supply available for distribution in 1918 was considerable smaller.

# FORESTRY PROGRESS IN NEWFOUNDLAND

By J. D. Gilmour, Chief Forester and Logging Superintendent,  
Anglo-Newfoundland Development Co.



## How Lord Northcliffe's Company Aims to Maintain its Forests as a Permanent Crop



About 15 years ago it was first realized that Newfoundland's forests, comprising about 8,000,000 acres on the Island itself, were better adapted for pulpwood than for saw-logs only. Previous to this time sawn timber had been shipped to Europe and South America. The superior adaptability of these forests for pulp and paper manufacture is due to several reasons. Among these might be mentioned the predominance of spruce and fir over white pine in quantity, the most accessible of the latter having been logged to a considerable extent. The comparatively small size of the spruce and fir made its utilization as pulp more economical than sawing it into lumber. Large rivers, with good power sites and extensive drainage basins well watered with drivable streams, afforded a choice of several mill-sites with ample power and with plenty of timber tributary to the mills by water. Newfoundland is 1,000 miles nearer Europe than are the chief Canadian ports.

One of the companies earliest in the field was the Anglo-Newfoundland Development Co., Ltd., which obtained its charter in 1905. This company was organized by Lord Northcliffe and associates, who chose the valley of the River of Exploits after obtaining reports on several alternative locations, both in Eastern Canada and

Newfoundland.

The A. E. Reed (Newfoundland) Company, Limited, about the same time located at Bishop's Falls, on the lower Exploits, nine miles below Grand Falls, the site selected by the Anglo-Newfoundland Development Co., Limited.

These two companies are both financed by British capital, and are the only pulp and paper companies yet operating in the colony.

### When Fire-Fighting Began.

It is safe to say that the inception of any forest laws in the colony was due to the efforts of these two companies. At the very beginning of the pulp and paper mill development it was seen that the colony's annual fire losses were disastrous in the extreme, and that, in short, another 20 years of unchecked fire losses would practically complete the total destruction of all the timber in the country. Fires were especially extensive after the completion of the cross-country railway in the '90's. These two companies brought this matter strongly before the Government of the day, with the result that the Forest Fires Act was passed. This Act was admirable in itself, but at first was not very successful, because of insufficient patrols and lack of inspection. Later, again at the suggestion of these two pulp and paper concerns, and other



The London Daily Mail in the making. Lord Northcliffe's pulpwood pile at Grand Falls, Nfld.

(Courtesy Natural Resources Intelligence Bureau.)



Into the teeth of the saws. At the foot of the jackladder of the slasher mill, Anglo-Newfoundland Development Company, Grand Falls, Nfd.

timberland owners whom they had interested, a voluntary association was formed, consisting of the limit-holders, and of the Government, to institute a patrol on the railway through forested lands. The expense of this patrol is borne by the Government which contributes about half, and by limit-holders who contribute the balance, roughly in proportion to their timber holdings.

The fire patrol system is administered by a Commission, consisting of the Minister and his deputy, and five or six resident representatives of the limit-holders. No serious losses have occurred on lands patrolled by this committee's appointees, since its inauguration in 1910. The cost to limit-holders averages about 60 cents per square mile annually.

This is a comparatively small expense, and is explained by the absence of interior roads, consequently there is not much travel in woods far from the railway. Lightning fires are unknown. Each operating company must control its own woods employees, such as loggers and drivers.

### Operate for Permanency.

In any paper on forestry progress, forest fire prevention is entitled to the first place which has been given it here. If sweeping and soil-destroying fires cannot be first prevented, the expenditure of money on forest planting, or on logging for a sustained yield, must be poor business. It may be stated that fire patrols henceforth will be adequate to meet conditions as they arise.

Regarding progress in forestry in other directions, the writer can only speak definitely for the Anglo-Newfoundland Development Co., Limited. The policy of this company is certainly to handle their limits for permanency, not to cut over once and close down. A forest survey was started before the war, and has been recommenced. This will eventually give a complete topographic and forest survey of the entire limits, nearly 2,500,000 acres.

Volume tables for computing strip surveys have been made locally. Growth tables, showing increment in volume, D.B.H., and height, for the different species and types have been made, although in some cases they require strengthen-

ing by further data. These so far are based on complete stem analysis. Regeneration studies, to determine what new growth has followed clear cuttings, and partial cuttings, and old burns, have been made. A number of sample acres have been laid out for permanent observation, and have been logged in various ways, different diameter limits, etc., with a view to finding out whether any logging system which will give a better second crop, is commercially feasible in the pulp business. This study will take some time, but seems the only way to get really reliable data, necessary for determination of policies.

### Burning of Slash.

Burning of slash in spring will, from observations made on burns, give a better proportion of spruce than is obtained by clear cutting and leaving brush to rot. Burning during logging seems to be more expensive; broadcast burning in early spring, when fire will scarcely run between the piles, gives results that promise well.

The hardwood problem is less serious here than on the mainland. White birch is the only hardwood, and hardly ever forms a pure stand, the natural types being mostly coniferous. Budworm injury has not been reported in the colony.

In logging, considerable progress has been made in close utilization, through cutting stumps low, and leaving no merchantable wood in tops. Practice usually will compare favorably in this respect with that in vogue in pulpwood cutting on this continent.

At the present time, no branch of forest investigation promises larger returns than studies directed towards solving problems of management of pulpwood lands for permanent use. In starting work on these problems, one is struck by the lack of practical, exact knowledge so important to the permanence of the pulp and paper industry. This industry should be a permanent one in Eastern Canada, and its importance in maintaining the prosperity of that section can scarcely be over-estimated.

### PIGEONS AS FIRE MESSENGERS.

Carrier pigeons used in fire protection on the forests in Oregon and Washington is the latest. Forest Examiner W. J. Sproat will inaugurate the experiment on the Deschutes Forest. He has five pairs of birds. Similar experiments will be tried on the Cascade. The plan is to use the pigeons as a means of communication in emergencies and for carrying fire reports.

### SEED TIME AND HARVEST.

(*Brockville Recorder*)

"It is sometimes argued that we do not need to concern ourselves about the forests of the future because the forests we now have will last us for 50 or 100 years, or even longer; that it is futile to worry about the matter, so long as we have wood. Of course, it is possible to estimate the length of time our present supply of timber will hold out, assuming certain fixed domestic and foreign demands (demands, incidentally, which are by no means fixed). This question has no direct bearing on the problem of keeping forest lands productive. Let us suppose, for example, that under certain estimated demands our present forests will last us for a hundred years. That is no reason at all why we should allow cut-over lands to become wastes or near-wastes. In the first place, it takes a hundred years, let us say, for a seedling to grow into a respectable tree, fit for the saw. The trees we are now cutting are, on the average, much older. The time to start our new forests, therefore, is now—not a hundred years from now—for otherwise we should have a long period during which we should be without adequate supplies of timber."

### GOOD WORK BY ROYAL BANK.

Many a helping hand is being extended these days to further the cause of forest protection. The Royal Bank of Canada has gone to much trouble and expense in issuing a large quantity of attractive blotters bearing the following legends:

CANADA CANNOT AFFORD  
FOREST FIRES!

Most forest fires are caused by campers and settlers. Light a small camp fire on rocks, gravel, or sand, never against a tree or in a dry bog. Put the fire out completely. Leave nothing smouldering. Never throw away a match or cigarette end when in or near a stand of timber.

CANADA HAS NOT ONE ACRE OF COMMERCIAL  
TIMBER TO SPARE!

With the Compliments of  
THE ROYAL BANK OF CANADA.

CANADA CANNOT AFFORD  
FOREST FIRES!

Make yourself a "Deputy Fire Ranger" whether in the woods this year for business or for pleasure and help to check the fire waste.  
Three quarters of a billion dollars' timber loss since Confederation!

With the Compliments of  
THE ROYAL BANK OF CANADA.

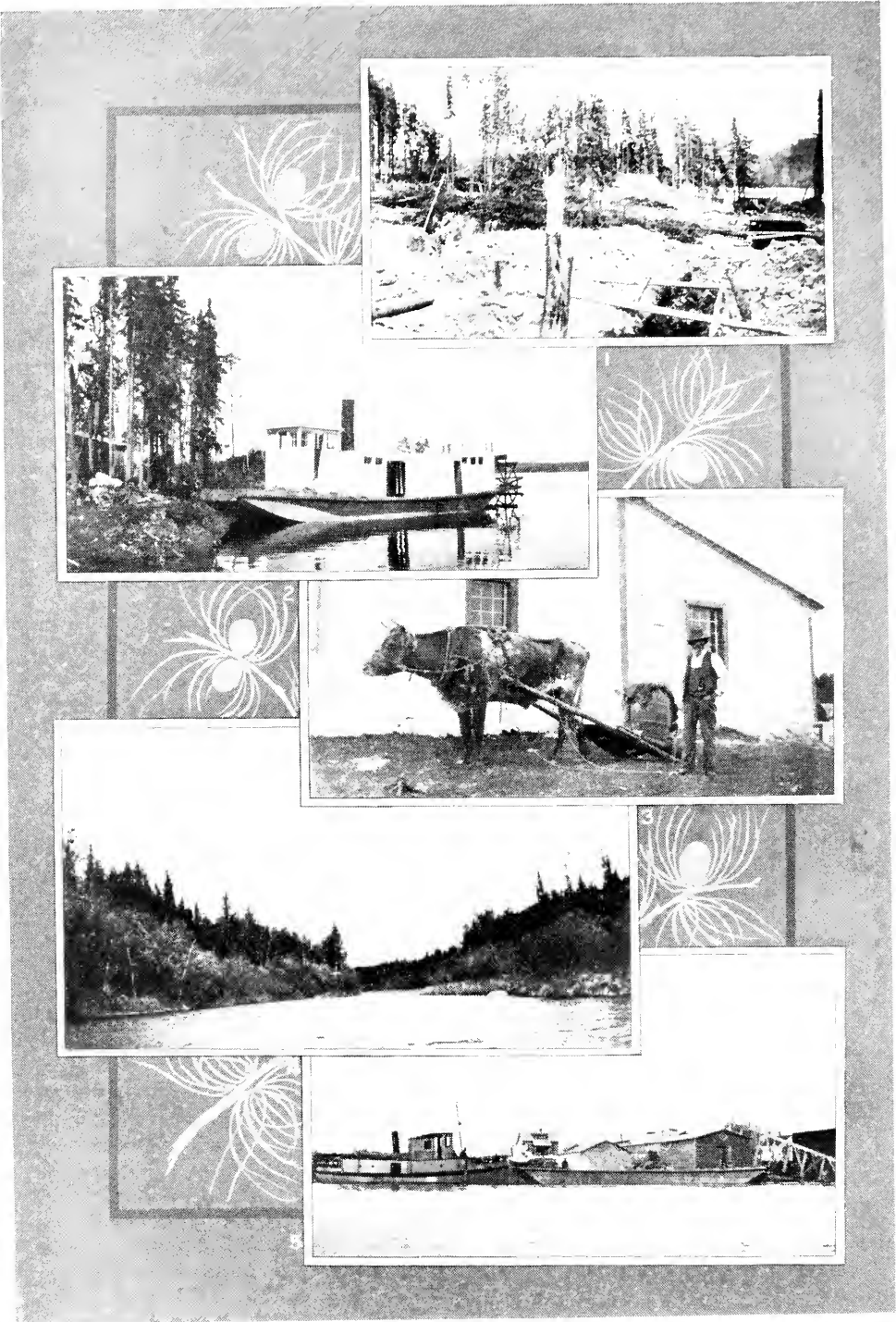

Picked up by camera in Northern Manitoba.

# AIRSHIP SERVICE IN FOREST AREAS

By Captain John Barron, R.A.F.

## Long Endurance of Lighter-Than-Air Machines a Point of Special Value.—Installation Costs.

I cannot give you information as to the work of aeroplanes for forestry duties, as my experience is entirely confined to airships, but for this particular work I would consider airships more suitable, amongst other reasons, owing to the fact that aeroplanes would have little opportunity of making forced landings in the thickly wooded districts, and the airship's facility in being able to hover or remain stationary in the air for purposes of inspection and on account of her long endurance.

I do not know if your intention would be to form a small service of your own men, or whether you would count on drawing from the personnel, supply and equipment of a Canadian air force. This latter would no doubt prove most successful, for as replacements were required, they could be drawn from such a service without causing any embarrassment, whereas replacements and other incidental expenses (always liable to crop up) having to be made good from a small organization might well strain the capital funds. I do not mean by this that it would prove impossible to carry out certain work with only a small capital available, but really that it would be more efficient to draw on nominal payment, from the resources of a larger Government-controlled service, the supply of which would not be felt by them, and the highest grade material would be available. This applies in particular to the early days of such an undertaking.

It might often prove a great temptation when not drawing from Government supply, to procure cheaper material, which in the end would result in loss in efficiency.

It is taken that the work necessary is forest protection and survey work.

### 28 Hours' Endurance.

The most suitable ship for these duties would be one known as the S.S. Twin Type. These ships have a cruising speed (40 m.p.h.) endurance of 28 to 30 hours, so that their radius of action would be 580 miles. Their dimensions are: length 165 feet, beam 36 feet, height 49 feet. A timber shed to take a ship of this

size might be constructed in the theatre of operations, but not being conversant with the conditions, I could not state the expense entailed by this.

If two or more ships were being used, it would no doubt be best to establish such a shed as a permanent base, and purchase portable sheds, which could be supplied with the ships for working further afield. I have never seen one of these portable sheds in process of erection, but understand they can be erected in a short time by a few skilled men and forty workers.

These portable sheds could then be transported north, south, east and west, with their respective tships, so as to cover a very large area.

If the question of expense did not permit the erection of a permanent base, then one or two portable sheds could be utilized as such, situated in the centre of the area to be worked, so that the radius of the circle would correspond to the radius of action of the ship or ships.

### Portable Sheds.

If desired then to work further afield without shifting the portable sheds acting as a permanent base, mooring out stations could be established, but in this case it would necessitate their being situated near a road, in order to transport hydrogen from the permanent base, or to allow a transport of a portable Silicol plant. No definite policy can very well be advised as to the methods for supplying hydrogen, as for instance the proximity of rivers might allow water power to be used, and thus bring down the cost of hydrogen production.

The following prices are quoted, and according to Air Ministry calculation, are subject to a decrease of 40 per cent for peace time:

|                  | War time | Less 40% |
|------------------|----------|----------|
| 1 S.S. Twin----- | \$40,000 | \$24,000 |

Twenty per cent of capital outlay is considered sufficient for all spare parts, envelope, etc., required in course of one year, keeping in efficient condition, and providing for rebuilding in case of accident.

|   |             |
|---|-------------|
| Running cost of hydrogen per hour (S.S. Twin) ----- | 1.80        |
| Portable shed to house 1 S.S. Twin -----            | 35,000.00   |
| Quarters and subsidiary buildings (100 men) -----   | 6,000.00    |
| Gas plant—depending on type and conditions -----    | Unknown     |
|   | \$41,000.00 |
| Less 40 per cent -----                              | 24,550.00   |

#### Personnel.

Complement for 4 S.S. Twin ships would amount to approximately:

Ships, 6 pilots; crews, 12 men; attached parties, 25 men; skilled men (trade classification), 50; unskilled labor, 30. Total, 6 pilots and 117 men.

In addition—commanding officer, landing officer, engineer officer, hydrogen officer, stores and accountant officer.

#### Estimated Wages and Salaries.

|   |           |
|---|-----------|
| Commanding officer -----  | \$3,000   |
| Landing officer -----   | 2,500     |
| Engineer officer -----  | 1,750     |
| Hydrogen officer -----  | 1,250     |
| Stores and accountant officer -----   | 1,000     |
|   | \$9,500   |
| Six pilots, \$2,000 each -----  | 12,000    |
| Unskilled labor at \$8 per week,<br>and skilled labor at \$15 per<br>week ----- | 39,000    |
|   | *\$77,140 |

The above prices are, of course, given concluding that such a service would not be drawn from a C.A.F.

I have endeavored to give more general information than advice as to organization, etc., as this cannot be given without knowing what the policy might be.

Editor's Note.—It is to be feared that Captain Barron's wage estimates are not based on present Canadian conditions. The amounts could be doubled with greater accuracy.

#### CANADA'S FUR ANIMALS.

Canadian fur-bearing animals constitute a resource which, in the last fiscal year before the outbreak of the war, provided exports valued at \$5,569,476, while even in 1916 the exports amounted to \$4,778,337. In addition to the furs exported, large quantities are used in Canada and the severity of our winters make it cer-

tain that this home demand will be permanent. Further, it will naturally increase with the growth of our population.

#### ONTARIO'S FOREST INCOME.

During the year ending Oct. 31, 1918, the Ontario Government derived a forest revenue of \$1,756,085 from its Crown lands. Of this, nearly half was derived from timber dues and approximately \$190,000 from the fire tax of one cent per acre per year for lands under license. The total revenue for the year is the largest since 1912-13, when the revenues closely approximated two million dollars. The area under license at the close of the fiscal year is reported at 16,888 square miles, or 574 square miles greater than for the previous year. These figures indicate the vital importance of Ontario's forest resources in furnishing revenue for the support of the provincial administration, as well as in furnishing supplies of raw material for the hundreds of wood-using industries of the province.

The permit system for regulating settlers' clearing fires is working out splendidly in practice. During 1918, 9,590 permits for the burning of slash by settlers were issued as against 3,486 for the previous season. According to the report of the Forest Service, the acreage covered by these permits amounted in 1918 to 39,683, as against 15,186 acres for the previous season. The permits are issued by members of the fire ranging staff, and the Provincial Forester reports that, generally speaking, the settlers co-operate heartily and appear to appreciate the wisdom of the new regulations.

The maximum number of rangers and supervisors was 1,190.

#### QUEBEC FOREST OUTLAY.

The Legislature of Quebec has appropriated \$100,000 for the provincial forest service and the inspection of lands for the fiscal year ending June 30, 1920; also \$7,000 for the maintenance of the provincial forest nursery at Berthierville. These amounts are very materially supplemented by the expenditures on forest fire protection incurred by the Ottawa River, St. Maurice, Laurentian and Southern St. Lawrence forest protective associations, which patrol the great bulk of the licensed and privately owned timber lands in the province. The expenditures of these four associations on fire protection during the past year total \$177,729.



## IN PREVENTION OF SHADE TREE BUTCHERY

### Electric Linemen Charged With Inconsiderate Mutilation of Valuable Specimens—Is Rate of Compensation Adequate?

In response to requests from many residents of Western Ontario, the Canadian Forestry Association has taken up actively the question of the legal rights and practices of public utilities companies and commissions in the destruction or mutilation of shade trees along the public highways and on private property. Of the many complaints received by the Association from owners of shade trees, a few proved to be so obviously unfair as to supply poor material in seeking remedial action. For example, some complainants have taken a position that they would not have their shade trees altered in any particular, even though the lighting and telephone facilities of an entire community depended upon their acquiescence. Another case was encountered in which a shade tree owner strongly objected to any lineman touching an oak tree on his property. It developed that the oak tree in question was badly rotted in the trunk and several of the heavier branches were ready to fall into the highway during the first severe wind storm.

In a letter received on June 9th from the Hydro-Electric Power Commission of Ontario, the following statement is made:

"It is the desire of the Commission to do as little damage as possible to the trees and properties of the people along the line of Hydro construction and they have secured the best help they could get to take charge of the trees to be trimmed and cut. However, any suggestions that you may have as to more skilled people in this respect, or improved methods of doing the work, will be appreciated.

"When you have completed your investigation I would be glad to have a copy of the result and any suggestions that you may have that will improve the situation."

#### Watch for Infractions!

The Forestry Association affirms that if every reader in Western Ontario will keep close watch on the conduct of linemen when carrying wires through trees and will supply details of any instances that seem to violate fair play, these will be brought to the attention of the Hydro-Electric Power Commission without delay. As

the Ontario law now stands the rights of the individual property-owner to the trees on his own property as well as to those in an adjacent highway, has been superseded by the amendments to the Hydro Power Act of Ontario so that at the present time the "Hydro people" have ample authority to handle shade trees as they see fit. Major W. W. Pope, Secretary of the Commission, in writing to the Forestry Association, emphasizes the point that notwithstanding the power given to the Commission, every effort is made to convenience the owners of shade trees and instructions are given to the working parties that minimum damage shall be caused, consistent with the economy of line construction. Says Major Pope:

"In addition to this, tree trimming matters have been very carefully looked into and wherever the trimming or cutting of trees is found necessary they have employed the most skilled experts that could be got, so that in carrying on this work as little damage as possible should be done to the trees, and have sought in every case to inconvenience the owners and occupiers of land as little as possible, having regard at all times to the efficient and proper construction of the lines and to secure efficient operation. In support of this statement the Commission have some thousands of miles of high and low tension lines in operation in this province and respecting which only two arbitrations have ever been sought, respecting trees, and less than half a dozen respecting land rights. It does happen that in some districts, owing to the Bell Telephone and other company lines having been constructed and operated on one side of the highway, the Commission are confined to the other side for the purpose of their line. One of the principal requirements for good operation, is non-interference with the line by trees."

#### Policy in Cities.

The Forestry Journal believes, however, that a vast improvement is due in the system of cutting shade trees in advance of line stringing. In cities such as Ottawa, where an official tree

trimmer is employed, it is the policy of the public utilities employees to submit all questions of shade tree alterations to the judgment of the aforementioned officer. It would seem, therefore, that in some of the larger places the city engineer's department must answer for the instances of shocking maltreatment of valuable shade trees.

### Is \$10 Enough?

As matters stand at present, the usual compensation paid owners of trees for their total destruction is a ten-dollar bill. This price may be adequate for some types of trees and will certainly be entirely adequate for Manitoba maples and horse chestnuts, which do not deserve encouragement in Ontario under any circumstances. Were the rate of compensation multiplied by five it is altogether probable that the shade tree trimmers would exercise more precaution, for presumably the engineer in charge of construction would be anxious to hold down his initial costs to the minimum. At a ten-dollar rate, however, it involves no serious outlay to condemn and destroy three or four hundred beautiful trees. Fifty dollars is little enough for a full-grown, well-shaped maple or elm. If a public utilities company or commission were compelled to put up that much money for every ruined tree, there would be more hesitation in applying the axe to fine old trunks. The United States courts have been accustomed to strike a higher estimate in shade tree damage cases than seems to be the case in Canadian courts thus far. Several instances

have come to the Journal's attention from the records of the Massachusetts Supreme Court. In one instance a tree butcher destroyed four maple trees and was forced by a jury to pay damages of \$100 a tree. Another case shows that an electric railway company paid \$1,200 damages for destroying fifteen tupelo trees. An assistant foreman of the street railway company cut down three sapling elms and mutilated one large ash tree. He was fined \$100. In Athol, Mass., a gas company, through neglect of gas mains, killed nine shade trees and was fined \$300. In Hampton County, seven trees were killed by gas and the company was fined \$700. Another company in Lowell on a similar complaint was fined \$900. Twenty-eight trees on one street in Springfield were damaged by gas and the company paid the property owners over \$2,000. A contractor engaged in moving a building in Lawrence cut off limbs of a shade tree standing in the way of his structure and his fine and costs amounted to \$400.

These instances seem to show a much higher valuation on shade trees than has yet been displayed in the compensation arrangements between Canadian public utilities bodies and private tree owners. United States court cases indicate that \$100 is by no means a high valuation upon a shade tree.

The Forestry Journal would welcome further evidence from readers in all parts of Canada as to the practices of linemen. This should comprise, wherever possible, specific details as to the age and condition of trees and the degree to which they were injured.

---

### SASKATCHEWAN'S PROTECTION

"The dry spell has been marked by an unusual number of prairie fires in Saskatoon district and provincial police officers have a busy spring-time tracking down careless farmers who neglect to plow fire-guards and otherwise endangered surrounding property. At provincial police headquarters here four 'crime reports' told of as many farmers being fined by rural justices of the peace in the last couple of days."—Saskatoon Star.

It will be interesting to learn of the Saskatchewan Government's efforts to track down any settlers responsible for the terrible forest fires of the last two weeks in May. Saskatchewan has a law forbidding the clearing of land by fire except under safe conditions and only by taking out a permit from a fire-ranger or municipal fire-guardian.

---

### WATERLOO TO PLANT.

The Waterloo Golf Club will plant on its property, near Galt, 200 trees, the gift of E. J. Zavitz, Provincial Forester. They include 50 Scotch pine, 50 Austrian pine, 50 Douglas pine, 50 Douglas fir, 25 white spruce, 50 white cedar and 25 bull pine.

---

### MR. A. L. DAWE GOING TO LONDON

Mr. A. L. Dawe, Secretary of the Canadian Pulp and Paper Association, is going to London as representative of the Canadian pulp and paper industry in connection with the work of the Lloyd Harris Commission. Mr. Dawe's sterling service during several years of critical pulp and paper history in Canada will ensure high efficiency in the new enterprise.

## PRIVATE COMPANIES ENGAGE FORESTERS

---

One of the most interesting and striking developments in Forestry during the past few years has been the initiation of tree planting operations by pulp and paper companies of Quebec, New Brunswick and Ontario, accompanied necessarily by the engagement of professional foresters. Mr. Ellwood Wilson, Chief Forester of the Laurentide Company, has prepared, at the request of the Forestry Journal, a memorandum showing the number of companies already using foresters. With the name of each company given below, mention is made of the chief duties allotted to the forester's charge:

J. B. Snowball Co., Chatham, N.B., estimating timber.

Price Bros. Co., Quebec, P.Q., commencing a nursery; planting this year about 300,000.

Belgo-Canadian Pulp and Paper Co., Van Bruysell, P.Q., estimating timber; said to be starting a nursery.

St. Maurice Paper Co., Three Rivers, P.Q., estimating timber.

Brown Corporation, estimating timber and control of operations.

Laurentide Company, Limited, planted this

year one million trees; transplanted one million and a quarter; advisory to logging division; estimating timber; experimental work; classifying lands.

Riordon Pulp and Paper Co., planted 750,000 trees; estimating timber; advisory to logging department.

Canada Paper Co., Windsor Mills, P.Q., planted 350,000 trees; estimating timber and mapping.

Spanish River Pulp and Paper Co., advisory to logging department; estimating timber.

Anglo-Newfoundland Development Co., Grand Falls, Nfld., in charge of logging operations; estimating timber.

Canadian Pacific Railway, in charge logging operations; planting, landscaping and estimating.

Wayagamack Pulp & Paper Co., Three Rivers, P.Q., advisory to logging department; estimating.

Abitibi Power and Paper Co., Limited, Iroquois Falls, estimating.

Southern St. Lawrence Forest Protective Association; managers of both divisions are foresters.

---

## BLOCKING SAND DUNES WITH TREES

Mr. G. C. Piche, Chief Forester of Quebec, writes as follows regarding the planting up of the drifting sand areas of Quebec.

"We have set there about 80,000 transplants of Scotch and white pine, also Norway spruce with a small amount of green ash and elms. The Scotch pine seems to have made the best show. Spruce appears to do well in some special corners. The hardwoods were only tried to fill up the gaps where there was a tuft of grass on the edges of the land to be restored. They have not proved to be very good though we met a few specimens apparently flourishing. The white pine has a delicate foliage and it will only make a good showing when its top about two feet from the soil. We have covered nearly 45 acres which we consider as reclaimed. On the remainder of the area (250 acres) we have sown beach grass with great success. As you know this herb will grow vigorously in shifting sands, and it has been

used extensively in Europe for the holding of the frontal dunes along the sea shores. It is our intention to resume the plantations this spring as we have about 75,000 trees which have been transplanted during two years on the grounds from which we intend to distribute through the beach grass zone.

"We have done similar work at Berthier Junction, but we have used there a different and perhaps more efficient method, that is, we have employed only Scotch pines and planted them a little closer than at Lachute. Then, we have protected the surface against the carrying power of the wind by covering it partially with brush and debris from birch trees. The result has been very encouraging. We have set there about 40,000 trees covering 25 acres, forming little patches here and there throughout the sand. The beach grass was also used but found not to give prompt results as it takes about three years before it makes any show.

"I firmly believe that the method employed at Berthier will give quick results and the loss of individual trees is very small. Naturally if there are any dangers of fire the brush will increase the chances of same.

"The average number of trees shipped from

the nursery during the last five years is about 500,000 and the present stock of the nursery is placed at 4,750,000, of which 3½ millions are spruces, half a million Scotch pines and the remainder consisting of various soft and hardwoods."

---

## BEAUTIFYING QUEBEC SCHOOL GROUNDS

By *T. G. Bunting, B.S.A., Professor of Horticulture.*

---

The school grounds of many of the rural schools of the Province of Quebec as well as in the other provinces are anything but attractive. They have been considered simply from the standpoint of a yard or playground and have been kept free of flowers, shrubs and trees, with few exceptions, and the buildings themselves are often plain and unattractive. Here and there through the country are school grounds that have been attractively planted with native trees and shrubs taken from the woods or with plants purchased from a nurseryman. The school teacher and pupils as well as the parents can and do take a greater pride in the country school where it is attractively laid out with trees, shrubs, vines and flowers, without these interfering with the space set aside as a playground. That school children will respect and help care for these plants has been demonstrated many times where these plantings have been made.

The Horticultural Department of Macdonald College has undertaken some work in this re-

spect and has been growing trees, shrubs, vines and perennial flowers with a view to planting representative school grounds in various parts of the province. An offer is made to the school commissioners to provide them with a quantity of plants for this purpose free of cost. The commissioners are asked to forward a sketch of the school grounds, buildings, trees or any landmarks on the property and from this sketch a planting plan will be drawn to scale suggesting the position that the different plants should be placed in. The school commission is also asked to pay express charges on the shipment and to take care of the planting according to the plan and directions forwarded with the plan and directions forwarded with the shipment. Visits will be made from time to time to these school grounds and instructions given as to the future care of the plants and assistance will also be given in pruning them and where necessary plants will be replaced.

Already a number of school grounds have been planted under this arrangement.

---

## SCHOOL PLANTING IN SASKATCHEWAN

By *Augustus H. Ball, M.A., LL.B., Deputy Minister of Education.*

---

It has been the policy of the Department of Education for many years to encourage the planting of trees and shrubs on school grounds in Saskatchewan. In 1915, when two directors of School Agriculture were appointed, arrangements were made with the superintendent of the Forest Nursery Station, Indian Head, whereby any school district, whose grounds were reported by the directors as having satisfactorily cultivated, would receive a large number of young trees of varieties suitable for shelter-belts or ornamental planting. Since that time about 300 districts have been supplied with ap-

proximately 800 trees each, and in most cases the trees are well looked after and consequently a considerable improvement in the appearance of the school grounds has been effected.

To successfully develop a good shelter-belt on the prairies of this province is not an easy matter and thorough preparation of the ground is absolutely essential. Very careful summer following is necessary and no trees are sent out until the superintendent of the Forest Station is assured that such preparation of the soil has been given.

## HELP FOR ONTARIO SCHOOLS

By A. H. Tomlinson, B.S.A., Lecturer in Landscape Gardening.

The Ontario Agricultural College, through the Division of Landscape Gardening of the Department of Horticulture, is giving special attention to the beautifying of rural home and school grounds.

Any rural resident or organization may write and procure advice free in connection with the

location of buildings, as farm or school, the planting of rural home and school grounds, churchyards, cemeteries, village parks, greens or playgrounds.

When plans are necessary for the laying out of grounds, those seeking help may send to the Department rough sketches of such.

## PLANNING A PRAIRIE TREE PLANTATION

(Courtesy, Dominion Forestry Branch)



Shelter Belts of Inestimable Value Can be Grown by Any Careful Farmer.



To obtain the best results it is essential that there be a definite plan in mind before any actual work is begun in the way of tree-planting. The majority of farmers on the prairies have the intention of planting trees at some time or other, but very few stop to consider what would be the best location and arrangement for the proposed plantation. Too often this lack of any definite plan of planting results in inconvenient and unsatisfactory home surroundings.

Where there is an initial plan drawn up, a portion of it may be completed each year, or as often as conditions will permit. It is known just where each belt will ultimately be established and the ground can be broken a season or two before planting and put into the best condition possible.

It may take a number of years to complete the plan, the length of time depending upon the extent of the plantation and the time and planting material available for distribution.

### Cautions Worth Noting.

A great number of farmers do not consider the amount of labor necessary to properly care for a thousand or more trees under prairie conditions, and very often plant a larger number than they have time to attend to. If the trees are planted and then cultivation is neglected, there is a loss of both time and money. A few

hundred trees well planted and thoroughly cultivated for the first three or four seasons will produce a better shelter than several thousand trees poorly planted and neglected.

A common mistake made on the prairie is the planting of trees on land which is insufficiently cultivated. Perhaps a piece of ground has been broken for a fire-guard, then at a later date it is decided to plant trees. Frequently this old fire-guard is chosen for the plantation without any thought as to the condition of the soil or the effect the plantation will have if located on that site.

### Formulating a Plan.

1. Make convenience your first consideration in arranging the farm buildings and grounds.
2. Establish the shelter-belt to protect the home and stock against the prevailing winds.
3. Allow sufficient room between the buildings and the shelter-belt for the extension and addition to buildings, threshing space, and collect snow-drifts in winter.
4. Allow space for lawns and ornamental planting.
5. Allow for the extension of the plantation for woodlot purposes.

### Convenience Has First Call.

Convenience should be the principal thought when erecting the farm buildings and laying

out the grounds. There is nothing which decreases the efficiency or value of the farm more than a cramped and inconvenient arrangement of the home and its surroundings. With every farm there is an approach to the road allowance which is used more than any other, and this should be kept in mind when locating the driveway in order that there will be no time lost when leaving or entering the premises. The same will apply to the entrances from the barns to the adjoining fields or vegetable garden. In nearly every case on the prairie farm there is a sufficient amount of ground which will allow the tree-plantations to be so located that they will not interfere with the convenience of the place and yet will provide shelter for the home and barnyard.

#### Prevailing Winds.

In every locality there is generally some one direction, or perhaps two directions, from which the severest storms approach. It is on these sides of the buildings that the shelter-belts should be established first. Many tree planters in the West endeavor to plant their trees so that they will serve as a wind-break and at the same time provide shelter for the buildings. It should be remembered that the main object of a wind-break is to afford shelter for the buildings and stock, and therefore it should be established on the sides which are subjected to the prevailing winds. Later, a few standard trees, such as the ash, elm and maple, may be planted individually near the buildings to provide shade.

#### Spacing the Shelter Belt.

There should be a minimum distance of one hundred feet allowed between any buildings and the wind-break. Where this requirement is disregarded, there is always a great deal of inconvenience experienced later from snow-drifts in the winter. If possible, it is better to allow a greater distance than one hundred feet. As the farm becomes better established there will be need of additions and extensions to the buildings, such as the construction of implement sheds, etc.

#### Ornamental Planting.

That the attractiveness of a place can be greatly increased by the planting of shrubs and flowers is known to all. But on the prairies there are certain conditions which determine the success in growing ornamental plants. It has been demonstrated at the Experimental Station at Indian Head that many shrubs which winter-kill in the open are quite hardy when sheltered by a belt of trees. Therefore, it is until sufficient shelter has been established by

the wind-break. On the ordinary homestead or new farm in the West there are many things, such as erecting buildings and fences, which are of more importance than ornamentation. But as the farm grows older there will be greater opportunities to plant shrubbery and improve the appearance of the place. That these conditions will arise at some future time should be kept in mind when arranging for the planting of trees.

Allow sufficient space between the buildings and the trees to make improvements in the future.

#### The Woodlot.

There is no expanse of territory where the scarcity of fuel and small timber is felt so keenly as on the plains. If properly managed, two or three acres of land planted with the proper species and in proper mixture will furnish a portion of the fuel used on the farm and will supply a quantity of posts and small poles. The area to be used as a woodlot should be included in the initial plan, and, at least a season in advance, a portion of this area could be prepared to accommodate the planting material available. Trees should not be planted in large blocks unless there is a narrow belt of trees previously established some distance away on the sides of the prevailing winds. A great deal of damage will occur unless there is a trap to collect the snow and keep it from banking up in the centre of the plantation.

#### Suggested Plans.

The plan here presented is offered merely as a suggestion as to what might be considered necessary to allow for in preparing an original plan for any farm home. Local conditions must necessarily affect the general arrangement of buildings and shelter-belts, and, therefore, no set plan can be given suitable to all cases. As a general thing from seven to twelve acres should be included in the plan; any area smaller than this will undoubtedly result in cramped quarters in future years.

The plan includes ten acres and is designed for a home site placed in the south-west corner of a section. It embraces practically everything that might be considered necessary in the way of gardens, ornamental grounds, barnyards and shelter-belts for a farm or from a quarter section to one section in area. It will be noted that the main belt on the north and west sides is planned for fifteen rows. It might with advantage be made even wider than this. It may be taken for a general rule that any belt containing ten or more rows should be protected by

a snow-trap or space to hold snow-drifts in winter. This space can be utilized to advantage for many purposes during the summer season. The outside belt on the north and west may consist of either one or two rows of such trees as maple, willow or caragana. Trees like cottonwood or ash, which do not grow thick at the bottom, should never be used for this outside belt.

Such a plan may require several years to complete, the ornamental grounds being possibly the last portion to be developed. To plant according to this plan the owner would require to use from 5,000 to 6,000 seedlings and cuttings, besides such shrubs as might be needed later for the lawns.

It must be clearly understood, however, that,

though these suggestions are made by the Forestry Branch, it would be an impossible task for the Department to supply sufficient trees to complete such a plan as above outlined.

A limited number of trees and cuttings are sent out each season from the Nursery Station at Indian Head, permitting of an average distribution of from 700 to 800 trees to each applicant in two successive seasons, making a total of from 1,400 to 1,600 plants. Beyond this the farmer must rely upon his own resources for further developing his plantation. Planting material may now be purchased at reasonable prices from common nurseries operating in the West, or the farmer may quite easily grow his own stock from seed or cuttings taken from the older belts of trees.

---

## THE PEOPLE'S RIGHTS IN WESTERN FORESTS

---

(From Report on "Forestry on Dominion Lands", by J. H. White, M.A., B.Sc.F., Commission of Conservation's "Forest Protection in Canada.")

---

"License conditions agreed to each year provide for renewal 'subject to the payment of such rental and dues and to such terms and conditions as are fixed by the regulations in force at the time renewal is made' This is a yearly warning, and changes have been made from time to time in the conditions attached to Dominion licenses. The enforcement of cutting regulations in the interest of the next crop would be no hardship, considering Dominion timber charges in comparison with other parts of Canada, and the increased value of stumpage since purchase. Besides, in the case of berths held for increment in value, the operator, through the natural growth, becomes the owner of wood product which was not on the berth at the

time of purchase, and which was not represented in the original bonus he paid

"What may be done is necessarily a financial compromise between what is best for the forest and the market conditions of the lumbering industry. At the outset no changes are needed in the license conditions. All that is necessary is to take advantage of them. The modern viewpoint in timberland administration is a working for continuity of crop, and the Dominion timber regulations make ample provision for this, as was shown in the discussion of the license clauses. But the carrying out of cutting regulations requires an adequate trained force in the woods, and not a handful of men with multitudinous office duties as well."

---

## BETTER DAYS FOR THE MERIT SYSTEM

---

In an article by Dr. C. D. Howe on "A Land of Forests Without Forestry", in the May issue of the Forestry Journal, the evil of political patronage in the forest services of Canada was discussed in such a way as to give readers an impression that patronage still held sway in the field service of the Dominion Forestry Branch. As the Journal has previously pointed out, the patronage evil was effectually uprooted from the Dominion Forestry Branch many months

ago by placing all appointments under authority of the Civil Service Commission. Since then, the keenest critic of "pull" in public appointments has had little cause to complain. The spirit of the new legislation has been closely followed. The Journal believes that the Dominion Government ought to be excluded from the sweep of Dr. Howe's criticism, as regards patronage interference.

## RAGING FOREST FIRES IN THE NORTHWEST

Damaging forest fires in Saskatchewan and Alberta have been reported during the last two weeks of May. While details of losses have not yet reached Ottawa, newspaper and other reports indicate that the timber loss will be considerable. Eight Indians were burned to death in the reservation north of Onion Lake and Lloydminster, Saskatchewan; other Indians were severely injured and food supplies and equipment destroyed. In a report in the Regina Leader, of June 4th, it is stated that the Indian settlements in the path of the fires passed through a terrible experience and that the people were forced to flee for days at a time to escape destruction. Aid was despatched from Regina by the Department of Indian Affairs.

Reports reaching the Dominion Forestry Branch show that more or less serious fires have occurred along the Big River in North-east Saskatchewan and on the Pines, Fort a la Corne and Porcupine Forest Reserves with some troublesome fires in the Peace River country and on the Bow reserve, in Western Alberta. The field staff of the Dominion Forestry Branch has been constantly busy in organizing fire-fighters and endeavoring to restrict the zone of destruction. On May 23rd the air in Prince Albert, Sask., was so dense with smoke that lights were turned on in the majority of offices and residences. Had it not been for the energetic co-operation of the population along the Cana-

dian National Railway on the Big River line, many of the towns and villages would have been wiped out. Four hundred railway employees were engaged at one period in fighting fire in the district about Prince Albert. A stiff fight occurred to save a million feet of lumber piled in the yards of the Ladder Lake Lumber Company at Big River. One thousand men in the employ of the company were organized in fire-fighting units and by energetic work kept the conflagration in control. Reports state that several hundred head of cattle were burned to death on various ranches along the Big River line. No mention has yet been made of loss of life in this section. The continued absence of rain created the greatest anxiety throughout the whole district north and west of Prince Albert. On the night of May 22nd a veritable gale prevailed and the horizon in every direction around the city was illumined by the glare of hundreds of conflagrations creating dense clouds of smoke.

The municipal authorities and people of Prince Albert made prompt and most generous preparation for the care of any refugees of the burned area. One example of this fine spirit was seen in an order to all hotels and restaurants to furnish free meals at the city's expense to any fire fugitives. The Regina Post states that the fires about Prince Albert are the most extensive in the history of the country.

## MAKING NORTHERN ONTARIO SAFE

One would think that after the terrible forest fire experiences through which Northern Ontario has passed, the agitation for free-running fires in order to clear off the land for settlement would have been somewhat discouraged. As it was after the 1911 disaster, so since the 1916 catastrophe, alleged friends of the Northern Ontario settlers are writing columns to the newspapers asserting the right of the struggling farmer to fire his slashes in any way he pleases.

The latest of these newspaper pleas appears in the Cobalt Nugget of recent date signed "Settler". In two columns of complaint regarding the hardship of having to take out a permit before lighting his land-clearing fires,

"Settler" never once mentions the fact that unbridled freedom in setting fire to forests in Northern Ontario has on more than one occasion established a chain of graveyards from New Liskeard to Cochrane. In countries with the peculiar conditions of Northern Ontario no method has yet been discovered for "burning off the country" without burning up the people. The 1916 disaster which supplied columns of anguishing details was the product of unrestricted **settlers' fires**. Any modification of the present provisions would deliberately withdraw the chief safeguard thrown about the thousands of men, women and children now resident in the Claybelt.



## PAYING OUR DEBTS WITH SCENERY

(By Robson Black in Toronto Globe)

### If Canada Can Draw 10 per cent of Europe's Tourist Travel Income Will be Half-Billion.

The Magnet of Outdoor Canada creates more national income and more employment than the Canadian fisheries, probably five or six times over. It is to be counted as a natural resource of such present profit and potentialities as to rank with the mines and forests. And yet it seldom wins even a corporal's stripe in the blue books of this Dominion's business. We have figured out the pulpwood and the sawlogs and mink skins, but the hidden gold of recreational splendor somehow looks too intangible for mention. With marvellously varied charms of Nature to which processions of restless trampers would find their way if they only knew, Canada retains the distinction of the world's shyest advertiser.

Good ideas and pretty scenery seldom get anywhere "on their own legs". What reader has not heard of Denver, Colorado, and yet Denver recently spent \$75,000 to introduce herself to you and me, and is on the way to reap \$50,000,000 returns from motor travel alone. We may be a self-governing people, but we leave the details of food, clothing, politics, charity and travel to the autocracy of the advertiser. So habituated are millions of folk to picking rail and boat tickets according to brain pictures painted by advertising science that only those lands maintaining a first-class ballyhoo have been able to turn tourist footsteps into large national income.

Thousands of our own people hitch up for San Diego and Los Angeles who never yet have conjured a curious interest in Algonquin Park or Banff or Rideau Lakes or Vancouver Island or Laurentides Park or southern New Brunswick. The sort of export traffic that transfers millions of Canadian dollars to Yellowstone National Park and New Hampshire and the New England coast can be countered and redirected almost as easily as to change the public's whim to another good brand of tooth paste. We must start right now to "sell" Canadian scenery to Canadians.

#### A World's Industry.

Tourist business, travelling, fishing, sight-seeing, have grown into one of the world's really great industries. Because it is, consciously, a quite unorganized idea with you and me to buy a ticket to Mosquito Inlet does not mean that your notion of travel is not as ponderable, commercially speaking, as a shipload of spindles. To turn 50,000 Canadians from the American border to a rollicking good time in the glorious outdoors of the Dominion, is, from the shocking viewpoint of trade and commerce, a profitable and really easy thing to accomplish. The country must advertise itself to itself. That would cut off a large slice of needless cash export. Simultaneously we could advertise the creational novelty of our country to others, to the millions of others with their pockets bulging full and a ready ear for the call of the wild, when the wild does its calling in a universal key. We could then settle down to something that has a more exhilarating motive—to teach Canadians how to play, how to build big business on last week's recreation. Just now we Canadians are in the way of thinking that a "month's rest" means a membership in a Gaspe salmon club. That is because we react according to the mental pictures we have formed from absurd data. It is also accounted for by the fact that almost nobody in any Canadian neighborhood, without a commercial interest to advance, does any picture painting for the fellow with a fish-pole and thirty-two dollars.

#### Department of Tourist Travel.

If some Cabinet Minister at Ottawa brought in a bill to create a Federal Department of Tourist Travel, would he be showered with flowers or flower-pots? It might help him to mention that the American tourists spent in France before the war about \$250,000,000 a year. The Rhine River brought to German coffers \$100,000,000 annually. Prior to hostilities 300,000 well-to-do Russians spent the summer at German and Austrian resorts and left

behind them something over \$200,000,000. Along the Baltic and North Sea 113 resorts held forth in 1913 and entertained over 800,000 visitors, who spent nearly \$100,000,000. Berlin picked up \$50,000,000 of foreign tourist cash, and Vienna considerably more in a twelve-month. American sources claim that 120,000 passages have been booked for France as soon as shipping is available, and so engaging are the possibilities of American traffic that the French Government has brought into being a new Cabinet portfolio, to be known as the National Office of Touring. Automobile services are being arranged, with new hotels, etc., to handle the swarms of spenders. With a possibility of \$500,000,000 a year from American pockets, how long will it take France to re-establish her financial power?

The Canadian Pacific Railway estimate that if Canada could secure just 10 per cent of Europe's tourist travel she would collect \$500,000,000 a year—the value of the wheat crop of 1916. The creation of a National Bureau for Tourist Travel has been put before the Dominion Government by the Commissioner of Dominion Parks, Mr. J. B. Harkin, an official of constructive outlook.

Can travel habits and travel routes be altered at will? The United States Government succeeded in the summer of 1915 in diverting to the National Parks over \$100,000,000 of the money that formerly went to European innkeepers and milliners. The total number of visitors to the American parks that year was 278,000. Canada's splendid group of National Parks in Alberta and British Columbia entertained 121,000 persons in the same year. They started for Canada from forty-five different nations and hit upon that particular part of Canada because the pictures painted by friends or by ad. writers or by the movies had settled their sense of direction. People who figure out that sort of thing reckon that they spent twenty or thirty million dollars with us while having a ripping time. But nobody comes unless someone mixes and paints and gives them, far and wide, a sketch of what's new, what's big and gripping. Along with that primeval tang the modern traveller expects at the very least a room and bath and valet service. He is willing to meet Nature and battle with her in all her moods—but he must do it comfortably.

#### Motherhood of the Forest.

The forest, of course, is the thing men go to meet when they quit the town for the un-

fenced playgrounds of the semi-wilderness. The forest is the mother of the pure stream and the crystal lake. It provides cover for the birds and food and shelter for animals. Granite ledges and boggy flats make hard fare for the recreation-seeker, unless every lifeless acre is instantly dissolved from sight by ten acres of life-renewing woodland. Canada will always be a country of enormous forests. Don't bother with these statistics much, but we have five hundred million acres in this good land covered with trees. Only a trifle of it is of any use for farming, so we will always—barring forest fires—have a snug little camping ground on 780,000 square miles—big enough to camp every living soul who feels the chumminess of living trees.

#### NEWS PAPER IS 92 PER CENT WOOD.

By way of explanation of the relative use of these factors it may be said, of Power that the energy required to produce one pound of newsprint is equivalent to one h.p. per hour and that about four-fifths of this is obtained from hydraulic power and one-fifth from coal: Of wood that is 92 per cent of the finished product, the remainder (with the exception of a fraction of 1 per cent of vegetable and mineral matter) is clean water."—W. H. V. Atkinson, in the Spanish River News.

#### MORE PAY FOR NOVA SCOTIA RANGERS

A Bill was introduced in the Nova Scotia Legislature recently to increase the daily wage paid to forest rangers and sub-rangers. The Bill was opposed by Messrs. Armstrong, Corey, Hall and Parsons, but succeeded in passing the House. The increase in wages will doubtless be regarded by all Nova Scotia members of the Forestry Association as a move in the right direction.

#### A RAILWAY IN PLANTING WORK

The Delaware and Hudson railway sets out annually 250,000 trees, mainly Scotch pine, spruce and red pine. The company has 17½ acres of nursery. Planting costs have increased \$2.50 per 1,000 trees during 1918, over the cost of the preceding year. It now costs about \$12 per acre for planting 6 x 6 feet or 1,110 trees per acre. On this basis the company believe planting to be a good investment.

## TWO SIDES OF BOUNDARY: IS THERE A PARALLEL?

Is there danger of timber exhaustion in America?

Ten years ago, it was the forester who raised the alarm. He was rated a visionary and a guesser.

To-day the forester is noticeably conservative in his point of view of timber exhaustion.

It is the commercial operator, official heads of great lumber associations, particularly in the United States, who seem to have taken the rostrum to rouse the people to a knowledge of dangers ahead.

Leading officials of the southern pine manufacturers state that the bulk of the original supplies of yellow pine in the South will be exhausted in ten years and that within the next five or seven years more than 3,000 manufacturing plants will go out of existence.

President Dodge of the International Paper Company, states that east of the Rockies, south of the Canadian border, there are only two stands of spruce that would justify the erection of two fifty-ton pulp mills.

Now comes further interesting evidence, this time from John H. Kirby, president of the National Lumber Manufacturers' Association of the United States, who makes the remarkable admission that of 202 sawmills in Texas, reporting to him as lumber administrator for the Shipping Board at New Orleans, ninety per cent had a shorter life than five years.

Since Mr. Kirby's address was delivered the United States Government has compiled, from the returns of the questionnaires which were sent out to the southern mills, supplemented by information furnished by the Southern Pine Association, data which shows that of the 2,043 mills reporting: 538 will cut out in 1 year; 539 will cut out in 2 years; 221 will cut out in 3 years; 120 will cut out in 4 years; 249 will cut out in 5 years—a total of 1,667 mills whose timber holdings will be exhausted within five years, representing eighty-one and six-tenths per cent of the mills reporting and twenty-one and nine-tenths per cent of their timber holdings.

Of the remaining mills covered by this census, 280 will have exhausted their timber holdings within the next five-year period; of which—47 will cut out in 6 years; 35 will cut out in 7 years; 48 will cut out in 8 years; 17 will cut out in 8 years; 133 will cut out in 10 years—leaving but 96 mills of the 2,043, or four and

six-tenths per cent of the mills reporting, that have a life of more than ten years, and of these all but four will have exhausted their timber holdings within the next twenty years.

### Canadians Should Heed.

What meaning has all this for Canadians?

Exhaustion of southern pine timbers which does not mean the clearance of the last tree, but the reduction of dense stands below the point of profitable operation, will automatically transfer the pressure of public demand to the white and red pine forests of Canada. The latter are supposed, on evidence none too secure, to contain sixty billion feet, board measure, most of which is confined to Quebec and Ontario.

Some large mills in Ontario, specializing in pine, are already feeling very sharply the cutting out of white pine areas and the increasing inaccessibility of fresh supplies of logs. If such is the case to-day, when southern pine mills are yet able to operate and produce cheaply on the last of their forest capital, what will happen to Canada's pine when United States demand begins to bear heavily upon it? Are Canadians free to assume that a candid investigation of their own situation in respect to timber supplies east of the Rockies, would develop a showing much more comforting than what is now represented by American lumbermen? Or is it not nearer the truth to say that we have only the haziest idea of what pine exists in Eastern Canada, and have not taken the trouble to commence a survey or to ask the lumbermen for a frank opinion of the future outlook, and then, on the plain evidence, work out a plan of state investigation and co-operation in order to safeguard the future from calamity?

### U. S. STARTS AIR PATROL

The air service of the United States army, in co-operation with the Forest Service, is now actively patrolling national forests in California for fires, and plans are in the making for the wide extension of this work as the fire season approaches in other sections of the country. On one patrol no difficulty was experienced in detecting fires, both large and small, in the timber at elevations ranging from 6,000 to 10,000 feet.

## "LAISSER FAIRE" IN LUMBERING

"Despite the warning furnished by the United States, the prophetic utterances of leading timber cruisers, and the clarion calls of the Commission of Conservation, there are those who still seem to take little stock in the gravity of the situation and evidently think that all the agitation which has been raised on this question savors much of the character of an ordinary political discussion or a passing campaign propaganda which, from a party standpoint, is to be taken with a liberal discount," remarks Canada Lumberman".

"There is, however, a deeper meaning and a more intensive character to this problem and to many others, if Canada is to maintain her prestige and predominance as one of the great timber, pulp and paper producing nations of the globe. It was ably pointed out by Dr. Howe, Faculty of Forestry, University of Toronto, before a recent gathering of business men in Toronto, that it was part of patriotism as well as of elementary business sense to make an effort to sustain an industry that creates annually for the country forest products valued at over \$116,000,000 a year, and affords employment

to many thousands of people. Dr. Howe is not an alarmist and is not given to exaggeration or sensationalism. He strongly emphasized that forestry practice was to maintain unimpaired the capital stock of the forest wealth, and to increase the earning capacity of the capital invested in the forest. This is the object of every business organization and surely Canada cannot do better than to see that the yearly cut does not deplete the growth to such an extent that the inroads of time and industry will bear so heavily upon our national resources that, like the individual who fails to replenish his wardrobe, his larder or his stock of merchandise, from time to time, will wake up some morning to find, before we are fully aware of the true state of affairs, that all we have left of this great natural and national heritage is shreds and patches. The best time to take full advantage of the present situation and adopt wise, aggressive measures, is now. Otherwise Canadians will bitterly realize the fact that so far as our wooded wealth is concerned the saddest of all words are "it might have been".

## U. S. PREPARES FOR FORWARD MARCH

On May 20 at Washington, D.C., was held the first of a series of conferences with a view to formulating a national programme of forestry. The conference was called and presided over by Henry S. Graves. Representatives were present from the states of Virginia, West Virginia, Maryland and New Jersey, and included state foresters, timberland owners, public men and representatives of the Federal Government. In opening the conference Col. Graves sketched out the timber situation that exists in the country to-day.

State foresters and others presented informal statements regarding the situation in their states. These reports indicated the following facts: the original forest has been completely removed in New Jersey and Maryland. It is very nearly gone in Virginia and is rapidly being cut away in West Virginia. In spite of fires in the past reproduction has taken place in most localities, and extensive cutting is going on in second growth. In some of the older localities the third and fourth cutting is being made. Generally the cutting now under way is very heavy,

either cleaning the ground or taking the trees down to six or eight inches in diameter for uses such as mine props, box material, poles and other materials in which very small trees can be utilized. Many wood-using industries have run short of supplies and some have been compelled to close down their operations. Organized fire protection is being carried on in all the states represented. In those localities where carried on it is effective in accomplishing the renewal of the forest, but some areas have been so heavily cut and burned that they lie completely waste with only a covering of bramble and brush growth. Fire protection of itself does not provide for a highly profitable forest. Additional measures such as cleanings, improvement cutting, thinning and even planting are necessary to the development of a high-class forest.

Following the line laid down by the forester the thought of the afternoon session was directed mainly to the following subjects: the step most needed is complete fire protection for all forest areas whether cut over or not. Fire protection affords the basis for forestry.

Finally, it was the deliberate thought and conclusion of the conference that the timber situation of the country is so serious as to make an immediate necessity the inauguration of a broad and far-reaching timber policy which shall bring under some measure of public control all forests of the country.

The sense of the meeting was expressed in the following resolution which was unanimously adopted:

Resolved, that forestry questions are national questions, as well as state and local questions, and it is the sense of the conference that the National Government should assume leadership in these matters and aid and co-operate with the several states in furnishing adequate protection from forest fires, in perpetuating existing forests, and in reforesting devastated forest districts or regions, upon such conditions as may seem just and equitable.

---

## OUR WATER POWERS AND REFORESTATION

---

The building of storage reservoirs for the conservation of water supply must be accompanied by wholesale reforestation, urges the New York College of Forestry in a special bulletin.

"The present interest in the development of water power in New York is emphasizing the problem of bringing about regular flow in streams for both power and domestic use. There is no question of course but that streams must be kept to a certain level throughout the year to be of value in the production of power. Where a stream fills its banks for a few months of the year and then dwindles to nothing, necessitating the use of steam power for the remainder of the year, these streams can be said to be of really little value to the state. There is no question but that the building of storage reservoirs at strategic points on water courses will assist in holding water back and allowing the streams to fill to a higher level through a longer period of the year, but the building of these reservoirs is only solving half the problem. If the forests are stripped off, allowing melting snow and rain to rush rapidly to the streams, this flood water will carry soil that will fill the reservoirs as rapidly as they are cleaned out. That this is the result of building reservoirs without proper reforestation of the headwaters of the stream has been evidenced repeatedly in the Alps in France and Italy, and in our own western mountains in California.

"Forests have a marked influence in conserving the water which falls in the form of rain and snow. The branches of the trees break the force of the rain, letting it fall to the ground and pass into the soil easily. The cover formed by decaying leaves and sticks is a sponge-like

mass called duff or humus, and this has a great water absorbing capacity. It takes up in proportion to its volume a vast quantity of water and gives it off slowly over a period of several months, thus maintaining springs and an even flow in the streams.

"General uniformity of stream flow in every section of the country will probably be brought about only as the result of widespread and intelligent reforestation combined with a limited number of large storage reservoirs at the headwaters of streams. If in connection with the reforestation of the barren areas, storage reservoirs are constructed so that the flood waters of spring may be impounded and given off gradually during the dryer seasons of the year, the combination of the two—the forest and the storage reservoirs—will come as near solving the problem of uniform flow in our streams as anything that can be contrived by man. Proper control of runoff is the only thing that will maintain a supply of water in streams upon which manufacturing industries are dependent and insure proper levels for navigation.

While forests act as protectors of the soil and conservers of water, they will be producing a crop of wood that will give increasingly large returns. There are, therefore, both direct and indirect benefits to be obtained from the reforestation of the non-agricultural hillsides and ridges which form so considerable a part of the great state of New York. There should be, therefore, constant co-operation between those who wish to develop the waterpower of the state or cities using water from our forests with the agencies carrying on reforestation. Without proper forest cover there can not be proper water supply.

# THE GREAT FORESTS OF SOUTH AMERICA

By Percy F. Martin, F.R.C.S.

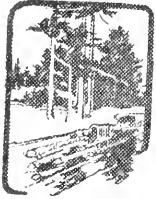

## The World's Last Regions of Unexploited Timber—Immediate Protection the Antidote to Quick Action.



The twenty sovereign states of what is known geographically as Latin America are possessed of natural resources—as distinct from manufactured products—of which the world has but an imperfect knowledge, and makes but a restricted use. A country, or a series of countries, with a superficial area of something over 8,000,000 square miles, must, necessarily, contain within its borders a vast number of natural resources of different kinds and various degrees of usefulness to man; and even to-day the inhabitants of those regions are ignorant of the riches a bountiful Providence has bestowed upon them or how to put them—where known—to the most profitable advantage. Whereas to several of the countries many of these gifts are common—such as timber, minerals and precious stones—others are possessed of resources peculiar to themselves; for instance, the nitrate of Chile, the gayule of Mexico, and the quebracho of Argentina and Paraguay.

Lt us consider the case of the forest-lands, a conspicuous feature in the majority of the Latin American states. If we except two small regions, the South American forests are composed of broad-leaved hardwoods. There is a close resemblance between these and the hardwoods of North America. Some are of between 10,000 and 20,000 feet board measure to the acre, and the common belief that tropical forests contain only very hard woods must be disabused, since recent investigations show these forests to be composed of soft or medium hardwoods which are as suitable for general construction as the pines and various conifers and hardwoods of North America and European forests.

The timber lands of Latin America—in which comprehensive term are included those of Central America and Mexico—can be roughly divided into four categories, more or less distinct, the species composing each varying from region to region, but the general effect of each type from Columbia to Argentina being much the same. Putting aside the employment of technical or botanic phraseology, these four principal types

of trees may be described as dry forests, temperate forests, swamp forests, and tropical rain forests. There are, of course, other and minor types, quite distinct in themselves, upon which further comment is unnecessary, since the object of this article is merely to show the character of the South American forests so far as they lend themselves to commercial exploitation.

The first or dry type of timber is to be found in the temperate or sub-tropical regions, and is met with at both high and low levels. Immense areas exist where the rainfall is either deficient or unevenly distributed throughout the year, thus occasioning long periods of drought. Such forest areas are usually covered with some form of growth which, at its best, is a dense mass of comparatively few species. The trees are short-boled, round-headed, often armed with spikes or thorns or short spur-like branches, and with harsh or bristle-pointed leaves. The trees do not usually exceed 50 feet in height, and in many regions the average is little over 25 feet. The commercial stem varies from 10 to 20 feet, with diameters of 12 to 24 inches common. These forests grade into chaparral on one side, and into tropical rain-forests on the other. Perhaps the best known representatives of this type are the quebracho-algarroba forests of Northern Argentina and Paraguay. These occupy the great semi-arid plain lying between the foothills and the Andes and the Parana and Paraguay rivers, known geographically as the Gran Chaco. Other representatives of this type are the Cotinga forests of Brazil, and the coast forests of Colombia and Venezuela between Cartagena and the Island of Trinidad.

### Antarctic Beech and Conifers.

The second, or temperate, type is met with along the slopes of the Andes, where elevation and moisture combine with suitable soils to make growth of a temperate forest possible. This type is best developed in Patagonia, and reaches practically to sea-level in Tierra del Fuego. Here, in the south, the trees are rather stunted

and deformed by the violent winds that blow for the greater part of the year, but higher up in the more peaceful solitudes of the mountains to the north, and along the shores of the Patagonian Lakes, timber reaches a splendid development, and heavy stands are met with. These forests are of Antarctic beech and a few conifers, and it is estimated that three species of the beech would probably furnish 90 per cent of the cut. Average stands are between 10,000 and 20,000 feet per acre, exclusive of defects.

Unfortunately, many of the forests are overmature and so defective as to be of little commercial value. The trees reach heights of 100 to 125 feet, and a diameter of between 2 feet and 5 feet. No reliable computation has ever been made of the timber in this part of South America, and the extension along the Andes region, drew on the forests for fuel and construction timber, and, no new growths having been promoted, only second growth, or scattered patches, remain. It has been found that these Highland people even worked down to the edges of the rain forests of the great Amazonian plain.

The third, or swamp, category forest can, again be subdivided into two classes: (a) The tropical forests occupying the salt-water swamps at the mouths of the great rivers; and (b) the forests of the fresh-water swamp and bottom lands. The tidal forests are typical mangrove areas, such as are to be found in other parts of the world, rather restricted in area and practically destroyed. The fresh-water swamps occupy great areas, and may undoubtedly, one day, become of some commercial importance. Among the best-known representatives of this type may be included the lowland forests that fringe the Amazon River in Brazil, the Orinoco in Venezuela, the Parana in Argentina, and the Magdalena in Colombia. These forests have similar characteristics, although they may differ in regard to the species of the trees found therein from north to south.

The forests of the swamp area are very irregular in age, often very open, and, maturing with extreme rapidity, only fast-growing species obtain a footing over much of the area. For the most part, the species in this type are soft wooded, similar to cotton-wood, basswood and yellow poplar, and many are quite colorless. The trunks reach to a height of over 100 feet in the best soil, and from 60 to 70 feet in the average, the ordinary diameter being between 2 and 3 feet. Certain of these species probably reached this height in a period of from 10 to 15 years, and their commercial diameters in much the

same time. The dominant stand from any given region is generally of very few species. In many cases four or five varieties of a tree will furnish 75 per cent or more of the commercial timber, and the yield will be between 8,000 and 10,000 feet per acre.

#### A Vast Storehouse.

Of all the types of South American forests the tropical rain forest is, perhaps, the most important and the least known. Here in these regions, almost untouched by the foot of man, are to be found mahogany, rosewood, Spanish cedar and numerous other classes of wood adaptable to commercial purposes. It is estimated that there is enough timber to keep thousands of lumber men at work without pause for hundreds of years, not even the Indians having, as yet, penetrated more than a mile or two into the jungle-like interior from the waterways.

This forest type in South America probably contains the largest and most valuable body of timber in the world, and, had shipping facilities permitted, vast stocks of some of the finest construction timber—the timber for pit props in particular—could have been brought over to Europe during the past four years, during which the scarcity of such material had been so keenly felt. Every care ought to be taken for the future that these regions be protected from possible destruction, and some kind of international agreement arrived at between European, North American and South American Governments for the institution of a strict forest administration. If these areas be destroyed, as the forests of Argentina, Paraguay and Southern Brazil are being wasted day by day, it would mean economic ruin, probably also absolute physical damage to land, climate, property, and continent. If, on the other hand, they are protected and properly utilized South America may become the centre of the world's lumber prosperity in the immediate future.

The tropical rain forests are composed of timber similar to that now generally in use. The woods are in the main soft or of medium hardness, and could replace yellow pine for construction, oak for finish and furniture, hickory for wheels and handles, and ash for agricultural implements. It has been said by a great authority upon timber, that from the infinite variety of these South American woods it is possible to find one for each industry more completely suited to its needs than those used to-day.

In working the forests, almost everything would seem to be in favor of the logger, conditions being almost ideal. Heavy stands are found over great areas absolutely level, and between ten and twenty thousand feet can be cut to the acre. Commercial diameters run between 2 feet and 3 feet, and the clear lengths to 50 feet or more. The total height of an average tree is well over 100 feet. In regard

to transportation, navigable rivers and streams reach nearly every part of the forest, and short hauls to floatable water are the rule. While much of the timber will float, it would probably be found more practicable and profitable to construct complete working plants close to the forests, dispose of low-grade products near at hand, and ship only the more or less finished products to the world's markets.

---

## DO TREES IMPROVE GRAZING ?

---

The Journal of Forestry has summarized a series of interesting observations carried on in Russia over a period of 25 years to determine the effect of trees upon the grazing value of land which formerly carried forest. An area of 110 acres was divided into 18 portions, some of which were kept bare of trees, while others were sown with grass and trees retained. The trees were deciduous, being birch and alder, the former a surface-rooting and the latter a deep-rooting species.

The observations showed finally that in two or three periods of great drought the value of the treeless lands fell off by from 12 to 50 per cent, while that of the grass land with trees increased to 16 per cent. In rainy years also the treeless grass lands were inferior. For the first 12 years the treeless areas carried the best grass, but

then their value suddenly depreciated and the clovers began to disappear, until after the lapse of 25 years the areas took on the aspect of moorland on which tillage, manuring, and sowing failed to make a permanent improvement.

On the areas planted with birch trees the grass continued to improve until about the twentieth year, when the meeting of the crowns and roots caused the grass yield to decline rapidly. It recovered rapidly, however, when the older trees were removed and a new crop planted. Under deep-rooting alders no deterioration was observed, the grass coming close up to the trunks without reduction in height or change in color. It is stated also that the beneficial effects of trees are to be expected not in wet but in dry climates.

---

## WAPITI SAVED FROM EXTERMINATION

---

A recent act of the Saskatchewan Legislature has established an indefinite close season for the elk or wapiti. This animal is now permanently protected throughout its entire range in Canada. This result has been achieved by the continued activities of an ever increasing circle of persons who take a keen interest in the conservation of our wild life. Various conferences of those interested have been held from time to time and their recommendations have been gradually adopted by the various provincial legislatures. Moreover, these conferences have done much to arouse and increase public interest.

The elk or wapiti, one of the largest of North American fauna, once ranged nearly the entire continent in incredibly large numbers, but has now become so greatly reduced that to-day a

few scattered bands along the Rockies between Colorado and the Brazeau river and some isolated herds in the forests of northern Manitoba and Saskatchewan comprise the entire wild elk left in North America.

Although now almost exclusively found in forests, the wapiti, which was originally an animal of the open plains and park-like regions, is unable to subsist on browse alone and is dependent, therefore, upon grass and weed range for its food supply. This peculiarity introduces an important element into the problem of its conservation, as the animal is obliged to expose itself more to the hunter than those species which never need to come out into the open. Consequently, only very drastic measures taken at once will save the wapiti from extinction.



## TAXING TIMBER LANDS TO EXTINCTION

At a meeting of the Society of American Foresters at Albuquerque, New Mexico, at the beginning of June, consideration was given to the reform of drastic tax laws applying to timbered areas. The following expresses the sense of the meeting:

"The passage of adequate timberland tax laws, with a tax on the land as real estate and another tax on the timber itself, but collected

only when the timber is cut or harvested. It was pointed out that all existing tax laws regard timber as a part of the real estate itself, instead of as a crop; that the timber is taxed continuously, although it takes two centuries in the southwest for western yellow pine to grow from the seed to the mature tree ready for cutting; and that it is therefore unprofitable for private owners to hold young timber for future cutting."

## A WHOLESALE LAND-CLEARING EXPERIMENT

According to a despatch in an Edmonton paper, an experiment in clearing land of tree growth by a wholesale burning method is being undertaken under the direction of the Dominion Government in Northern Alberta.

"Several townships are included in the area, a large part of which is now covered with dead poplar, having been laid waste by bush fires a number of years ago. Enough men were taken north to serve as an adequate fire-guard force, and it is expected that the work will be completed in the course of another few days. The Alberta fire guardian's office has also sent a representative to observe the progress of the experiment and the degree of success with which it is meeting.

The purpose of the work is to ascertain whether or not the clearing of land by burning is feasible. In certain parts of the north country considerable tracts of potential farming land are now covered either with brush or dead wood, and the clearing of such land for agricultural purposes has hitherto been a slow and somewhat expensive process. The Department of Interior is therefore trying out the plan of controlled bush fires, and the party now at work in the Smokey River district will shortly submit a report as to whether that plan is practicable on such a scale and whether or not it is any improvement upon the old-fashioned method of cutting and piling for bonfires."

## THE NEW DEFINITION OF FORESTRY

*By Dr. Hugh P. Baker.*

Stories brought back from the war areas and reports from Government bureaus in Washington show that France has suffered more than any other European country in the drain upon her forests. It has been well said that French forests bore the brunt of the war. Other raw products could be shipped much more easily from other countries, but the products of the forests because of their bulk and because of the shortage of shipping facilities could not be imported readily. Therefore, the French forests were called upon to supply the French, Belgian, and American forces in their operations along the entire western front. At the close of the war there were over 50,000 British, American, and Canadian soldiers cutting timber from the

French forests. This number was in addition to the French engineers and civil population and thousands of German prisoners who were used in getting out and transporting timber products.

### Twenty Years' Growth Gone.

It will be some time before we appreciate fully what the drain upon the French forests resulting from the war actually means to France and to the countries associated with her. The war demands upon the French forests have been estimated at seven times the normal production of her forests. For the two years ending December, 1918, the total timber requirements of the associated Governments were approximately 600,000,000 cubic feet of saw log timber. This tremendous demand upon the French forests had

to come from a greatly decreased forest area, as over 1,230,000 acres of forest land was in the territory occupied by the Germans. The loss of the acreage of forest land meant an annual loss to France of approximately 17,500,000 cubic feet of saw log timber last year. It is estimated that the drain upon the French forests in the past three years in the way of timber is equivalent to the growth of twenty years. In other words, the growth of the next twenty years of the French forests has already been used.

It is probable that there was a heavy drain upon German forest areas throughout the period of the war, but the German policy has always been to make occupied territories pay the cost of war in every way. It is known that the Scandinavian peninsula and Russia were drawn upon by Germany for vast amounts of timber in the carrying on of her war activities. Even Spain and Portugal, which before the war were the least densely timbered countries in Europe—Portugal having but  $3\frac{1}{2}$  per cent of her area in forests—were badly over-cut. It has been reported that the demand for timber was so great in Spain, of course for export to Allied countries, that even cord oak trees were cut down in numbers. It became necessary in countries of Northern Africa, in Greece, and elsewhere to pass rules forbidding the cutting down of olive trees.

#### Russia Out of Action.

It may be said, therefore, that outside of Russia and the Scandinavian peninsula European forest industries are so exhausted that years will be necessary to bring them back to the pre-war conditions. Russia, in her demoralized and disorganized condition, will probably not be able to regain in any large way the European markets for her timber for a decade at least. It is probable that Russia could pay much of her war debt through the utilization of her forests could she organize her Government and her railways.

#### Forestry is Growth Plus—

A hundred years of forestry in Europe have shown that nothing is to be gained by confusing it with engineering or agriculture or any other equally definite line of work. Forestry is defined as not alone the production of a crop of trees—and this phase has been the one emphasized in this country too long—but as the harvesting of the forest crop and its ultimate utilization. It means the production and propagation of the animal life of the forest and forest waters, and finally it means the marketing of the products of certain recreational developments in the

duct. In the last decade forestry has come to forestry of this country, as evidenced by the recent activities of the United States Forest Service in the development of recreational possibilities of the national forests.

Not until foresters throughout the country look our forestry problems squarely in the face and define what we are attempting to do in a fair way will we be able to achieve what is expected of us in these years of reconstruction. Naturally a developing profession such as ours must go through a period of uncertainty of definition and be hindered by attempts to call things what they are not. Any one who is at all familiar with the development of medicine in this country will understand thoroughly the many difficulties and delays which have resulted from lack of clear understanding in the defining of the boundaries of the science and the practice of medicine.

This is a time when those of us concerned in the development of forestry should have vision not only in defining forestry but in appreciating its relation to every phase of our national life. The period when production—or silviculture—was the all-important phase of forestry has passed in this country and we are being conceded, though begrudgingly by some, that the utilization of the forest with all it means is a part of forestry. The field of utilization offers tremendous possibilities in the way of research and in the way of making the results of research of a very definite practical value to every lumber user.

#### Wild Life Included.

Again, it is becoming understood gradually that forestry should include the production and propagation of the wild life of the forest and forest waters. This very important phase of forestry work has been bandied about from place to place, settling for a time with one line of work or in one kind of an institution, but there is no question that long experience in Europe shows that the forester is the man who is most concerned with the development of the animal life of forest lands and forest waters. There is some attempt to include this line of work as a phase of agriculture. We will concede that agriculture is one of the great industries of the country and needs the loyal support of every citizen and every legislature, but agriculture has its hands very full in developing to the fullest extent the agricultural lands of the country with all that that means. Will you agree, then, that forestry is a land problem, a water problem, a raw products problem, a food

problem, and a recreational problem? It is a field big enough and roomy enough for all working for forestry in a state of this kind.

In the problem of the supply of water for the state for both potable and industrial use the forester must play an important part. Because of tremendous industrial development as a part of our war activities, great interest is bound to be taken in the development of the water power resources of the state. The forester should assist in the development of these waters, but at the same time should emphasize the necessity for the carrying out of reforestation by the state of barren hillsides and ridges which form so large a part of many of our watersheds. Experiments in the Alps in France and Italy and in our own western mountains show that money

may be wasted easily in building storage reservoirs if reforestation does not go on apace and does not keep the soil on the hillsides and the mountainsides, preventing it being swept off by flood waters into these reservoirs. Instead of passing huge annual appropriations entirely for river and harbor improvement, we must show that it is good business and good forestry to put a part of these funds into reforestation of the watersheds, thereby making it annually less necessary to dredge and improve our rivers and harbors. The state is fortunate in having the greatest city in the world within its bounds, and we have an obligation to that city that those who live there shall have the best water and the best food and the best recreation that our agricultural and our forest lands can give them.

## AN OPINION ON BRUSH DISPOSAL

"There are various methods in use for disposing of lumbering slash, varying in cost and effectiveness. No uniform system can be followed. The method used must take into consideration particularly the injury to the remaining trees, and whether the conditions following the manner of disposal are favorable to the seedling crop desired."

"As far as Dominion forests are concerned, with the exception of certain portions of the railway belt, logging would be of very doubtful value, since decay takes place very slowly, owing to the dry climate."—By J. H. White, M.A., B.Sc.F., Faculty of Forestry, University of Toronto, in Report to Commission of Conservation, 1913, based upon field studies on Dominion Lands in Western Canada.

## DOMINION RAISES TIMBER PRICES IN B. C.

Official intimation has been received in British Columbia that a new schedule of royalties on timber berths west of Yale and within the 20-mile limit has been sent from the department at Ottawa to go into operation May 1st. These new rates are an increase over those of 1918, but it is explained that the Dominion Government has found it necessary to raise additional funds to meet post-war obligations.

Mr. E. F. Stephenson, chief inspector of crown timber offices with headquarters at Winnipeg, was in Vancouver towards the end of April in connection with the matter. He told the "Western Lumberman" that all the timber lands of the Federal Government had been held very low so far as taxation is concerned and that, in comparison with the provincial holdings adjacent to the 20-mile limit, the Dominion timber is considerably below the rate and that further taxation can still be imposed without being an added burden.

Alluding to the policy of the Dominion Gov-

ernment in regard to the manufacture of pulp from Crown lands timber, Mr. Stephenson stated that there had been no definite policy, but that he anticipated this would be done at an early date. The new royalties on the Crown timber lands in the Yale district are as follows: ground rent lands formerly 5 cents per acre will, after May 1, be 10 cents; on saw logs the jump is from 50 cents to 75 cents per thousand; on shingle bolts the increase is from 25 cents per cord to 50 cents, and on poles piling and cribbing, from  $\frac{1}{2}$  to 1 cent. On railway ties the advance is from  $2\frac{1}{2}$  cents to 4 cents, and on cordwood 15 cents to 25 cents per cord. An ad valorem rate is set on all timber not enumerated at 10 per cent. This was formerly 5 per cent.

An increase has been made in the rentals east of Yale of \$5 per square mile, bringing the rate now up to \$10 per square mile. This is one-tenth of the rental charged by the provincial timber department of areas in the same district.

# CANADA'S FORESTS AS AN IMPERIAL ASSET

By Robson Black, Secretary, the Canadian Forestry Association.  
(From the University Magazine.)

In the light of war experience, one is not called upon to argue the value of forest supplies to a belligerent nation. The grave predicament in which the Allied armies on the western front would have been placed had Britain's home timber supplies been their sole reliance is not to be contemplated with comfort. Had France been unable to thrust into modern warfare at a day's notice the powerful, perfectly organized weapon of great national forests, no display of generalship or human fortitude would have availed against the German onrush. It is not surprising, therefore, to find not only in the British Isles, but in the overseas dominions a remarkable quickening of public interest in forestry policies, and new determinations that, despite the lethargy of the past, the notorious shortcomings common to the whole Empire shall not be imposed upon the future.

It may be that where the plodding foresight of the French and German sylviculturist for a century past missed the Anglo-Saxon completely, the picturesque mass-play of forestry battalions in days of war will be the means of forcing the importance of national forest management upon his peace time policies.

Of a certainty, the citizen who persists through these grilling years in his traditional contempt for national supervision of timber production invites catastrophe upon his country even if nothing worse than a trade Armageddon lie before us. But there are bound to be considerations of physical safety taking priority to trade. In any future war, the conduct of military movements will depend probably, even more than in 1918, upon an unflinching supply of timber materials, which in turn must be anticipated far in advance by national forestry organization, with public sentiment and public resources patiently upholding its programme. We have lived through the unprecedented spectacle of nations mobilizing not only fighting men but women and boys, factories, mines, railroads, forests, and farms. Where shall one discover another such unprophesied enterprise as the transfer of 10,000 woodsmen from Ontario and Quebec and British Columbia to the forests of the United Kingdom and France? Or could one parallel in military history the hewing down of 30,000

French trees every day, and the transfer to the fighting front of 200 million board feet of timber a month?

To the British observer it may appear at first sight that the forests of Canada are but distantly related to the timber supply problem of the United Kingdom. In all treatments of this subject which the present writer has read, the probability of Canada engaging more extensively in the British timber trade is subordinated to other schemes having Russia, Sweden and Norway as their forefront and reliance. Admittedly these countries have in their favor a very much lower freight charge, and none will dispute that Russia, in particular, with 1,200,000 square miles of timber lands, is competent to stand the strain of any conceivable demand.

## The British Viewpoint.

The Forestry Sub-committee of the British Reconstruction Committee has, however, struck a new note in its recent report. It has ventured to consider the possibilities of a larger trade in timber with Canada, and goes far in suggesting practical steps toward that goal. The effect of the report in Canada almost certainly will be to demonstrate to the Dominion and Provincial forest administrations that timber conservation has suddenly taken on a serious imperial aspect, demanding an immediate application of scientific guidance and statesmanship such as would redeem some of our overseas forest policies from their present low estate.

The main object of the Forestry Sub-Committee, naturally, is the planting up of suitable areas in the United Kingdom so as to overtake in time the great discrepancy between coniferous timber consumption and home production. But the best-favored planting scheme demands patient waiting and heavy investments from the public treasury, either through direct payment for planting operations or by readjustment of taxation methods. Meanwhile timber must be had in undiminished quantities, and that means importation from mature forests beyond the British Isles.

It is one of the odd developments of the war that the forests of Canada were outlawed for military requirements by the need of eliminating timber cargoes from the shipping lists. For the

greater part of the war period more ships were being used for timber than for any other British import, and this continued long after American wood cargoes were cut off. Canada, therefore, was obliged to content herself with sending forest labor in place of forest materials. The exceptions are to be found in a considerable export from Canada of chemical derivatives, such as acetone, used as a solvent for the fibres in high explosives, and the Imperial Munitions Board's demand for 125,000,000 board feet of Sitka spruce (*Picea sitchensis*) for aeroplane construction. (Only 15 to 20 per cent of a spruce log is accepted for this purpose.) There has been at least one other tangible contribution to the Imperial cause: I refer to the undoubted development of public sentiment on forest conservation, the new determination of the Governments to antidote the havoc of forest fires, and the slow dawning—not more as yet—of the rudiments of sylviculture in treatment of forest properties.

Meanwhile the past attitude towards Forestry, or "conservative lumbering", of most wood-using industries in Canada may be summed up in the old phrase, "Say nothing but saw wood". Much wood has been sawn, without doubt. The country has dipped deep into capital account and imperilled the sources of future interest. In a broad sense, this was inevitable. The forests have fallen victim to spread-eagle estimates, in which the lumberman was victimized quite as much as the public administrator. Scarlet calculations were wholly unopposed until very recent years; need one be surprised that public and private forest policies dragged at the tail of the procession? Our pioneer fathers' enmity for the blockading tree trunks stuck fast. We were at no time world travellers and students of foreign procedure. We did not see that timber possessions attend the highest state of civilization, and in the most efficient nations of Europe are the more jealously guarded as pioneer days recede.

(Continued in July issue.)

---

## WHAT IS FORESTRY?

---

"This field of management of forests for continuity of crop passes under the name of Forestry. Forestry is merely the business of handling timberlands in an improved way for perpetual revenue. It is often considered antagonistic to the lumbering business, but this is erroneous, because forestry is completely de-

pendent on lumbering. Its intensity of practice is in direct co-ordination with the status of that industry. It is regulated lumbering, lumbering so regulated with the aid of technical knowledge that the forest may produce revenue forever."—J. H. White, M.A., S.Sc.F., in "Forestry on Dominion Lands."

---

## HOW TO PRUNE YOUR TREES

---

Always use a pole saw and pole shears on the tips of the long branches.

Do not "head back" or cut off the top of a tree except where the tree is old and failing, and then under special instructions.

Be as sparing and as judicious in pruning as possible, and do not raise the branches so high as to make the tree look like a telegraph pole.

Commence pruning the tree from the top and finish at the bottom.

Make every cut as close and parallel to the

trunk as possible.

To make the cut perfectly smooth the saw must be well set and sharp.

Leave no stubs, dead and dying wood, or fungus-covered branches behind you.

Do not fail to cover every wound with coal tar, not allowing it needlessly to run down the trunk.

Do not remove several large branches on one tree at a time. They must be removed gradually, the work extending over several seasons.

## CONFEDERATION LIFE ASSOCIATION

### UNCONDITIONAL ACCUMULATION POLICIES

Are liberal up-to-date contracts which guarantee to the insured every benefit consistent with safety.

#### WRITE FOR PARTICULARS

which will gladly be furnished by any representative of the company or the

HEAD OFFICE,  
TORONTO



**QUEEN'S  
UNIVERSITY**  
KINGSTON,  
ONTARIO

**ARTS**  
Part of the Arts course may be covered by  
correspondence.

**MEDICINE EDUCATION  
APPLIED SCIENCE**  
Mining, Chemical, Civil,  
Mechanical and Electrical  
Engineering

**SUMMER SCHOOL NAVIGATION SCHOOL**  
July and August. December to April

26 **GEO. Y. CHOWN, Registrar.**

## R. O. SWEZEY

(B.Sc., M.E.I.C.)

WATER POWERS. TIMBER LANDS.  
FINANCING

164 St. James Street - MONTREAL.

## P. L. BUTTRICK

CONSULTING FORESTER

NEW HAVEN, CONN., U. S. A.

P.O. BOX 607

TIMBER ESTIMATES  
UTILIZATION STUDIES  
PLANTING PLANS

Landscape and General Forestry Work.  
Eight years experience in practical  
forestry work of all sorts.

## UNIVERSITY OF NEW BRUNSWICK

FREDERICTON, N.B.

### DEPARTMENT OF FORESTRY

Established in 1908.

Best of facilities for definite instruction  
and supervision in Practical Forestry.

Surveying, cruising and construction  
work carried on in our own tract of 3600  
acres, with Forestry Camp in the centre.

Competent men from the School at  
present in demand to take up Forest Sur-  
vey work with the Provincial Crown Land  
Department.

For further information address:

### DEPARTMENT OF FORESTRY

University Calendar furnished on application.

C. C. JONES, *Chancellor.*

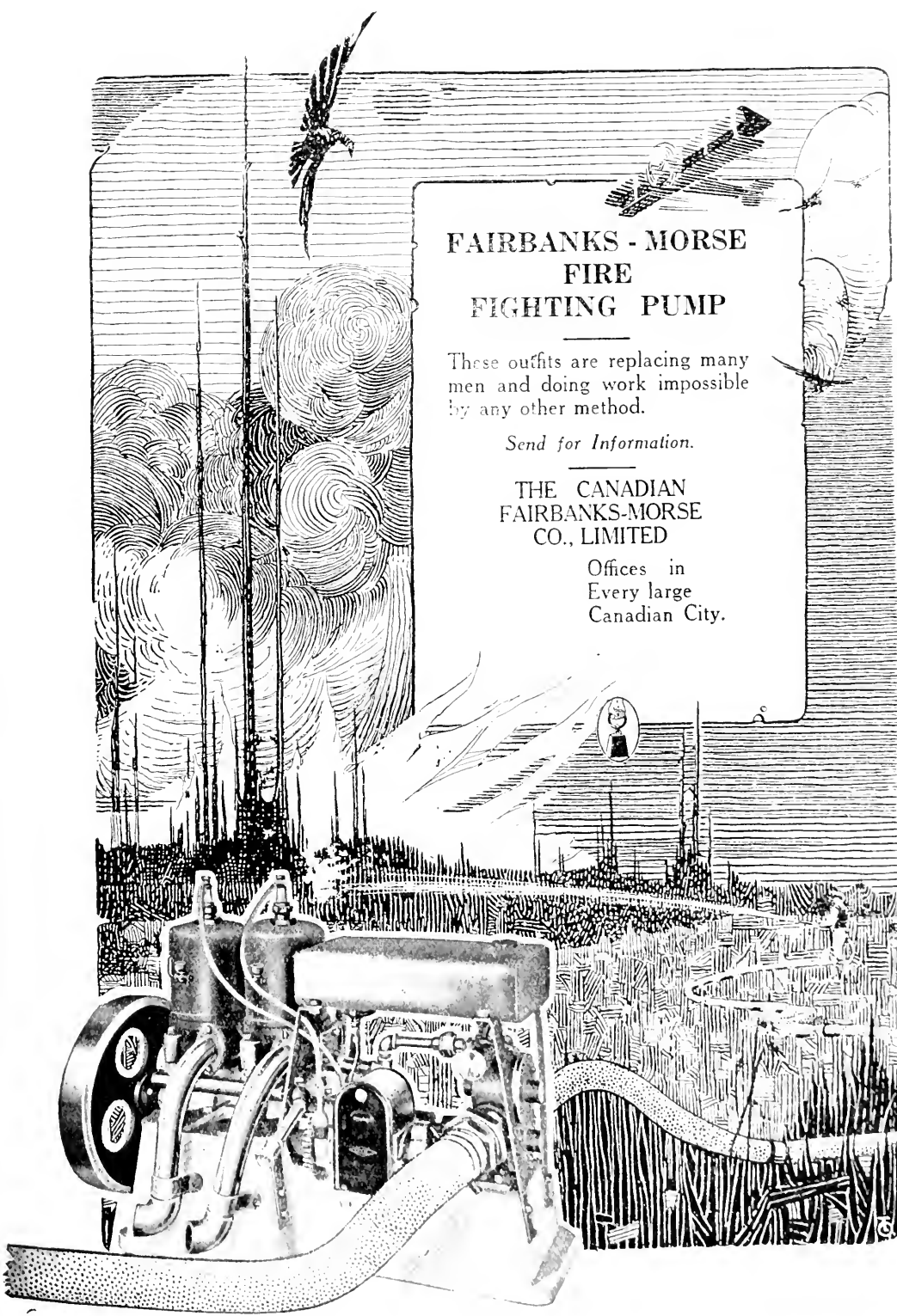

**FAIRBANKS - MORSE  
FIRE  
FIGHTING PUMP**

These outfits are replacing many men and doing work impossible by any other method.

*Send for Information.*

**THE CANADIAN  
FAIRBANKS-MORSE  
CO., LIMITED**

Offices in  
Every large  
Canadian City.

## DESTROYERS OF THE FOREST

"The Canadian Forestry Association has a man's size, life long job on its hands in its work of protecting the future of Canadian industries that are dependent upon the forest and which are seriously threatened with extinction by carelessness with regard to fires," says the Pulp and Paper Magazine. "They have recently put out a booklet in which the story of a camp fire is given as a dialogue between the spirit of flames and a boy who went out in the woods for an adventure. This certainly should bring home to the careless camper not only the danger of leaving a fire that is not completely extinguished or allowing a camp fire to get too large, but it also contains some of the most pointed directions for extinguishing a fire that we have seen. The whole thing is presented in an interesting way that makes very good reading and can be made the basis of a very lively evening's meeting for a troop of Boy Scouts or Camp Fire Girls

or even for a reading lesson in a school classroom.

"Efficient forest protective organizations are necessary, but the most important of all considerations is to have an intelligent public whose conscience will not permit them to throw lighted matches or hot pipe ashes or cigarette butts promiscuously about the woods, nor to leave camp fires with a single live coal, or permit settlers to burn brush except under perfectly safe conditions. Railroads are pretty well regulated and the fires from locomotives are becoming quite infrequent while section hands are also taking more care in regard to the danger from fire. It is the general public and the individual conscience that must be appealed to in order to prevent fires from starting. It is only by keeping fires from getting a start that we can hope to make our forests completely safe from this danger."

## LECTURES IN FRENCH SETTLEMENTS

Mr. A. H. Beaubien who last year made a success of a lecture tour in French-speaking districts on behalf of the Canadian Forestry Association, is again holding large public meetings in Quebec, this time with the aid of motion pictures. One of the best of the films is entitled "The Enemy of the Forest" and gives a striking illustration of the ordinary causes and effects of forest fires. The film was prepared by the Publicity and Exhibits Branch of the Depart-

ment of Trade and Commerce, under the direction of Mr. B. H. Norrish, and is regarded as the best educational film on the subject yet produced in Canada or the United States.

Mr. Beaubien's meetings have been in the French-speaking settlements along the Mont Laurier division of the C.P.R. and will be continued south of the St. Lawrence in the territory of the Southern St. Lawrence Forest Protective Association.

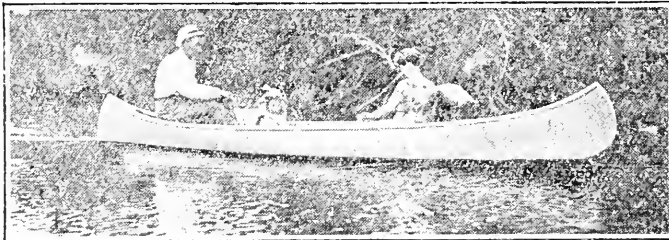

### THE FAMILY CANOE

Paddling is a most pleasant summer pastime. It delights the old and the young.

### CHESTNUT CANOES

are the ideal canoes for everyone. They are staunchly built for comfort, strength, and durability. The rib work and lining are made of toughest New Brunswick Cedar—The whole body is covered with a seamless sheet of specially-woven canvas treated with a very efficient water-proofing preparation. A Chestnut Canoe is leak-proof and safe.

The Chestnut Pleasure, Sponson, and Cruiser Canoes are the best canoes for any kind of aquatic sport or pastime.

THE CHESTNUT CANOE CO., LIMITED.

BOX 460, FREDERICTON, N.B.





## FOREST TELEPHONES

Make the life of the forester better worth living. They relieve him from the appalling loneliness. They help him to keep in human voice touch with foresters miles away.

In emergencies—fire—sickness—hunger—the speed with which they can summon help is marvellous.

Write for full particulars of how to install the Northern Electric Forest Telephone System. Address the Office nearest you.

*Northern Electric Company*  
LIMITED

|          |          |           |
|----------|----------|-----------|
| Montreal | Toronto  | Regina    |
| Halifax  | London   | Calgary   |
| Ottawa   | Winnipeg | Vancouver |

***Northern · Electric · Forest · Telephones ·***

### TIMBER OWNERS SOON TO FLY.

Grand Mere, P.Q., June 11.—On last Sunday, at seven o'clock in the evening, the first flying boat that Grand Mere has ever seen, flew over the town at a height of 2,800 feet, and five minutes later alighted on the surface of Lac a la Tortue, where it dropped its small anchor for the night. In a few minutes, after securing the machine to her permanent buoy, the crew, consisting of Lieut. Stuart Graham, his wife, and his mechanic, Kehre, had been rowed ashore where they were greeted by an excited group of people. They were at once motored into Grand Mere, where Mr. and Mrs. Graham have their home and children.

This was the first commercial flight in Canada, and the first time that a flying machine has flown from Halifax to the Province of Quebec. It was the most successful of pioneer voyages in every way, and one which marks the opening of an epoch of commercial flying which is going to place Canada in the foremost ranks of aeronautic utilization.

Mr. Graham was most emphatic in saying that the trip could not have been done more

satisfactorily, and no engine could have worked better. It is an eight cylinder Liberty motor. He also says that his only wish is to be able to take as many of the officials of the association for a cruise over their timber limits as possible. There will, then, he feels sure, be no question whatsoever in any one's mind that this method of carrying on his future work is most efficient and practical. One ride in the "Bus" and you've fallen for the simplicity of the whole business; to use a slang expression. The future of aviation could hardly find a more immediate and valuable field for development.

This scheme has been made possible by the financial aid of Hon. Jules Allard, Minister of Lands for Quebec, and by the Hon. C. C. Balantyne, Minister of Marine, who made it possible to procure the planes. The work of patrolling the forests on days when danger from fire is great will commence directly Mr. Graham has returned from Halifax with a second machine. Aerial photographs and photographic maps of forest lands, and otherwise unmapped sections will also go on, and no time will be lost in widening the scope of work for which this project has opened up possibilities.

## MACHINES TO FELL TREES

(Correspondence in *American Lumberman*)

"The waste from timber from our present way of felling trees is enormous and altogether out of reason. Hardwood and hemlock they invariably saw off 2½ to 3 feet from the ground and in a time like this when hemlock butt would go for pulpwood and bring \$8 per cord and hardwood butts would go into cordwood and bring the same price, or would make the butt log of the trees that much longer, it is astonishing that we should allow that waste to continue. A machine should be perfected in the way of a light gasoline engine that could be carried on handles by two men and set on the roots of the trees and dogged to the roots and a cross-cut saw could rapidly cut off the trees close to the ground. I should think the manufacturers of gasoline engines and machinery would have taken the matter up before this and I wish you would publish some kind of an article on this subject and see if you can stimulate some of them to do this."—Inquiry No. 106.

The above inquiry comes from an old-time Wisconsin lumberman and is interesting as showing an increased interest in this subject.

The development of a satisfactory power driven portable tree felling saw is a subject that has not entirely escaped the attention of inventors and engineers. One concern is working upon a motor truck carrying a saw at the end of a swinging arm which is adapted to be brought into action into the side of the tree to be felled. Presumably the truck would start off on its own power when the tree began to fall and thus get out of danger, although if the tree is properly wedged and particularly with a patent screw power wedge which has been devised for the purpose, it is quite certain to go in the direction that has been prepared. A German invention purposes to drive a wire around a tree (belt fashion) with sufficient speed to heat the wire by friction, so that it might burn its way through the tree. Another cutting device suggested has been a chain saw. The ordinary cross-cutting saw has been hitched up to a reciprocating piston to be driven by either steam or compressed air. A circular saw on a swinging arm is carried by a carriage running on a semi-circular track which is laid down about the base of the tree. This saw is driven by a small electric motor. Another invention uses a drill as the cutting tool, boring a series of connecting holes about the tree; and this can be done if desired at a sufficient depth below the surface of the soil to leave nothing

above ordinary plow level. No one has attempted thus far to invent a power axeman, using the familiar swinging axe as the cutting tool. No one seems to have studied the possibilities in this line for pneumatic reciprocating or rotating cutting tools, which have been widely applied to other uses. One of the large electric companies started in to investigate the possibilities in this field for electric power, but it does not seem to have gotten anywhere. If any of these developers have discovered a machine that entirely solves the problem of felling trees by power in a way that is portable, flexible and economical he has up to the present time "hidden his light beneath a bushel".

## TO REFOREST CUT-OVER LANDS

Among the important propositions under consideration at Washington, to utilize cut-over timber lands in the south is one involving a survey with a view to extending the production of forage crops for livestock. A conference presided over by Assistant Secretary of Agriculture Christie has urged Secretary Houston to recommend legislation of this nature. The plan includes problems of reforestation with a view to utilizing large areas of cut-over lands for the reproduction of timber. It is pointed out that there are approximately 100,000,000 acres of cut-over lands in the south Atlantic, Gulf and lower Mississippi Valley States. The area is increasing annually. In Michigan, Wisconsin and Minnesota are 50,000,000 more acres which should be surveyed and utilized. If undertaken, the work would ultimately reach all sections where there are large areas of cut-over lands.

## STOCK TAKING ON CROWN LANDS

An effort is being made to speed up the work of classification of New Brunswick Crown lands, and about six survey parties will be in the field this year, three in charge of land surveyors, who will run all control lines and boundaries between Crown land and granted land, three parties will be in charge of foresters, who will carry out the work of cruising and soil classification. A special party will work under the direction of Dr. C. D. Howe, of Toronto University, to carry out the study of annual growth and establishment of permanent sample plots, in order to establish what the annual growth of the province is.

## FORESTS OF SIBERIA.

The great forest resources of Siberia have, up to the present, been exploited to only a very small extent. The development of the timber industry is essential for the future, if the normal trade of the country is to be restored. It is estimated that there are 810,000,000 acres of timber land in Asiatic Russia, two-thirds of which are accessible for commercial purposes. German and Swedish machinery has, up to the present, been chiefly employed for saw-milling purposes, but there is a good opening for the introduction of Canadian saw-milling machinery and logging appliances, especially in Eastern Siberia.

## SHEEP VS. TREES.

"We have seen that forestry may give employment to 30 men as against one man on sheep, but this is with the proviso that the forest timber is close to its market. It cannot walk 1,000 miles to its market, feeding itself on the way like a flock of sheep."—D. E. Hutchins.

## MOTION PICTURE MACHINES

## STEREOPTICONS

We are fully equipped to supply projection apparatus on short notice.

LANTERN SLIDES and  
Motion Picture Film made  
up in twenty hours.

Write for Catalog.

## PROJECTION DEPARTMENT SUPPLIES COMPANY OF CANADA

65 SPARKS STREET,  
OTTAWA, ONT.

## FORESTERS!

We want you to know  
all about our

## "ARCTIC EIDERDOWN SLEEPING ROBES"

It is to your own personal interest and  
comfort to own an Arctic Robe.

—Manufactured only by—

WOODS MFG. CO. LIMITED  
OTTAWA

"Booklets Ready for Mailing."



## DR. FERNOW, DEAN OF FORESTERS, RETIRES

Dr. B. E. Fernow, Dean of the Faculty of Forestry, University of Toronto, will retire on July 1st. It is Dr. Fernow's intention to return to the United States and, if health permits, to continue his labors in authorship which have already won him much distinction. The success of the College of Forestry at Toronto is mirrored in the success of so many of its graduates, as to be relieved of further complementary emphasis in these columns. Dr. Fernow has given of himself unsparingly for the advancement of forestry science in Canada. One cannot over-emphasize the discouragements attending long years of spade work in founding a new and unfamiliar branch of technical training, the youngest of the engineering professions. Through it all, Dr. Fernow has never lost faith that the utilization of the forest resources inevitably must be harnessed to silvicultural principles and that the business sense of the Canadian people

would, in time, insist upon adequate forms of state regulation. For that reason Dr. Fernow, as a Director of the Canadian Forestry Association, was a great believer in educational propaganda and assisted it at every opportunity.

He became Chief of the Division of Forestry,

United States Department of Agriculture, in 1886, a position which he filled until 1898. In addition to his official work, he was a constant promoter of all biological investigations leading to a broader understanding of the principles of forestry. In 1883 he was elected secretary of the American Forestry Association, and later also held the position of chairman of the Executive Committee, and finally first vice-president of that organization. The degree of Doctor of Laws was conferred on Dr. Fernow by the University of Wisconsin in 1897. He took up his duties at Toronto University in 1907.

### WESTERN AUSTRALIAN PUBLIC SERVICE PERMANENT POSITIONS UNDER THE PUBLIC SERVICE ACT.

Applications will be received until May 31, 1919, for the position of Working Plans Officer in the State Forestry Department.

Salary, £504-£636.

Applicants must be qualified foresters having a degree or diploma of a forest school.

G. W. SIMPSON,  
Public Service Commissioner.

Perth, Western Australia.

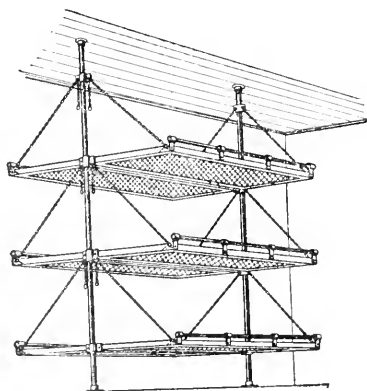

### STEEL BUNKS FOR CAMPS

Included in the well-known line of DENNISTEEL factory, hospital, camp and ship equipment is the all-steel sanitary bunk illustrated. Take up very little room, are comfortable, hygienic and practically indestructible—a permanent investment. Write for particulars and folders on any of the following lines: Steel Lockers, Bins, Cabinets, Chairs, Stools, Etc. Standardized Steel Shelving (knock-down system), Steel Hospital Equipment, General Builders' Iron-work. Ornamental Bronze, Iron and Wirework. Wirework of every description.

THE DENNIS WIRE AND IRON  
WORKS CO. LIMITED

LONDON  
CANADA.

HALIFAX    MONTREAL    OTTAWA    TORONTO  
WINNIPEG    VANCOUVER

IF YOU WANT A CHEW  
THAT WILL JUST SUIT

YOU ASK FOR

**STAG**

**CHEWING TOBACCO**

RICH AND SATISFYING.

IT IS ALSO KNOWN TO BE  
"EVER-LASTING-LY GOOD"

**TREES, SHRUBS and SEEDS**

HARDY NORTHERN TREE STOCK

**EDYE-DE-HURST & SON, DENNYHURST**

DRYDEN, ONT.

Shippers to H.M. Government.

**Hill's Seedlings & Transplants**

ALSO Tree Seeds for Reforesting. Best for over half a century. Immense stock of leading hardy sorts at low prices. Write for price list and mention this magazine.

Forest Planters Guide Free.

**The D. HILL NURSERY CO.** Evergreen Specialists

Largest Growers in America.

Box 503. DUNDEE, Ill., U.S.A.

**Try This Stump Puller at Our Risk**

The Smith Stump Puller will take out every tree and stump by the roots, clearing from one to three acres a day, doing the work of twenty men. We want you to send for our 3 year guarantees against breakage and our free trial proposition. Address **W. Smith Grubber Co.** 11 Smith St. LaCrescent, Minn.



**GAGNON & MORISSETTE**

TIMBERLAND CRUISERS  
LUMBER CONTRACTORS  
FOREST INDUSTRIES

CHICOUTIMI, - - P.Q.

**LT.-COL. L. J. D. MARQUIS**

Forest Engineer and Mem. Can. Soc. of F.E.;  
Quebec Assoc. of F.E.; Former  
Mem. Que. F. Service

Timber Factors and Logging Costs  
Facts on Forest Growth and Future Products  
Forest Cruising and Mapping  
90 LOCKWELL AVENUE - - QUEBEC

**Timber Lands Bought & Sold**

Timber and Pulp Wood Estimates.

**R. R. BRADLEY**

CONSULTING FORESTER

Globe-Atlantic Bldg. - ST. JOHN. N.B.

ASK



FOR



**Timber Estimating & Mapping**

Management of Forest Properties.  
Supervision of Lumbering Operations.  
Forest Planting.

**COOLIDGE & CARLISLE**

FOREST ENGINEERS

BANGOR - - - - MAINE.

**Timber Estimates**

JAMES W. SEWALL

Old Town, Maine.



(Courtesy Dominion Water Power Branch)

IN BRITISH COLUMBIA'S OUT-OF-DOORS

1. Great Central Lake, B.C.
2. Looking up Sproat Lake, Vancouver Island.
3. Cameron Lake, Vancouver Island.
4. The Head of Great Central Lake.
- 5.



2582

(Courtesy Dominion Water Powers Branch.)  
Lumbering in the Clearwater Valley, Athabasca Country.



**A PERFECT DAY.***Douglas Malloch, the Lumberman Poet.*

I call just this a perfect day:  
 To rise refreshed from dreamless sleep  
 To hear the matin roundelay  
 Of birds that by my window keep  
 Their little homes and are so glad—  
 And then to greet the morning sun,  
 Forgetting all the woe I had,  
 To find a new-born day begun.

To breakfast simply and go forth  
 To lift again the daily task,  
 Attempt again some work of worth—  
 What more than this can mortal ask?  
 Then all the day to toil beside  
 Some new-found friend, or old and true,  
 And life's ambitions to confide  
 In someone who is dreaming, too.

And then at last to come to night  
 Without a hurt, without a wrong,  
 And find the stars are kindled bright  
 And all the heavens lit with song—  
 With sweet and well earned weariness  
 Again my homeward way to wend  
 And know a fireside and caress  
 Await me at the journey's end.

I do not ask for idle ease  
 Or hectic pleasures, ample wealth;  
 I ask such simple things as these,  
 As work rewarded, love, and health;  
 Some hope to dream of, faith believe,  
 Some friend beside me on the way,  
 And love to greet me at the eve—  
 I call just this a perfect day.

**COMPANIES ENGAGE FORESTERS**

D. C. A. Galarneau has resigned his position with the Algoma Central and Hudson Bay railway and has accepted a position as forester to the St. Maurice Pulp and Paper Company with headquarters at Three Rivers, P.Q. Mr. Galarneau is now conducting an extensive forest survey upon the limits of this company.

A. C. Volkmar has severed his connection with the Riordon Pulp and Paper Company, to become forester to the Canada Paper Company, with headquarters at St. Raymond, P.Q. Walter ab Yberg, who has been connected with the Riordon company for some years, and has lately been in charge of their cruising operations in the Kipawa district, has been placed in charge of the forestry operations of the company, including the nursery and planting work. Mr. ab Yberg is assisted by H. D. Jewett.

**FORWARD STEPS IN NEW BRUNSWICK**

Lieut. H. S. Laughlin, B.Sc.F., who recently resigned from the New Brunswick Forest Service to accept the forestership of the J. B. Snowball Lumber Co., will conduct a forest survey on their limits by a co-operative agreement, whereby the results will be available to both the company and the government. A somewhat similar arrangement has been made with the Randolph & Baker Co., of St. John, and 140 square miles in Madawaska county will be covered before August 1st, through their co-operation. The work will be done by the government survey parties.

## TREES FOR MEMORIAL PLANTINGS



Special quotations on quantity lots of  
 Shade Trees, Weepers, Evergreens, etc.

*Send for Catalogue.*

## STONE & WELLINGTON

The Fonthill Nurseries

TORONTO

ONTARIO

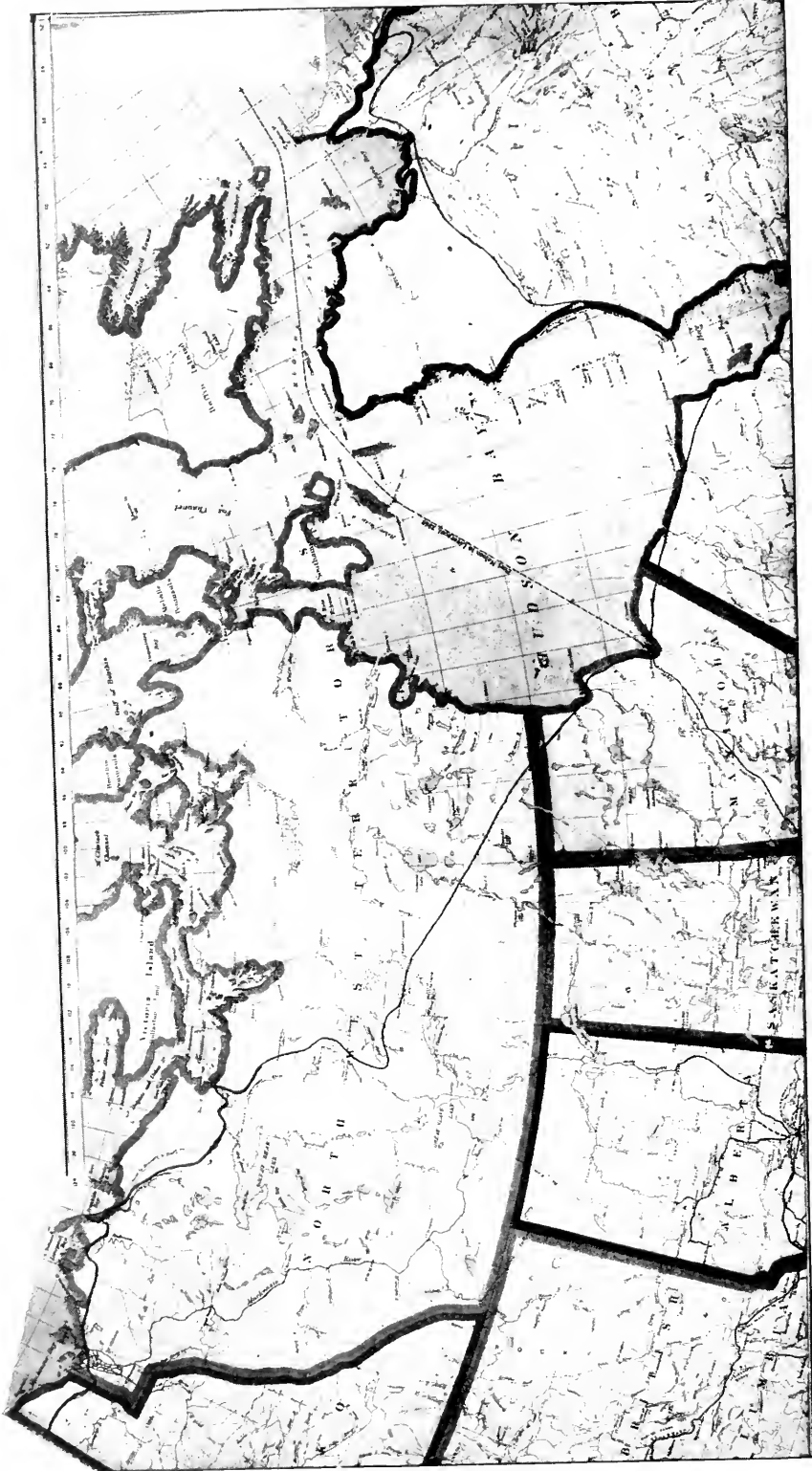

VILHJALMUR STEFANSSON'S OWN MAP OF CANADA'S NORTHERN TIMBER LINE.

At the request of the Canadian Forestry Journal, Mr. Stefansson drew the thin black line from the Alaskan border to a point north of Great Slave Lake, showing the limit of tree growth. The remainder of the timber line across Labrador was filled in from standard maps. Heavy black lines indicate boundaries. Mr. Stefansson found a considerable growth of trees in sheltered spots of Victoria Land.



(Courtesy "Canada Lumberman")

The splendid sort of timber harvest that the progressive forest policy of New Brunswick aims to make a perpetual asset. Photograph taken on the limits of the Bathurst Lumber Company.

## TABLE OF CONTENTS, JUNE, 1919

|   |     |
|---|-----|
| The First Flying Patrol of Forests.....     | 243 |
| Forestry Progress in Newfoundland.....      | 245 |
| Airship Service in Forest Areas.....        | 249 |
| In Prevention of Shade Tree Butchery.....   | 251 |
| Private Companies Engage Foresters.....     | 253 |
| Blocking Sand Dunes With Trees .....        | 253 |
| Beautifying School Grounds .....            | 254 |
| Planning a Prairie Plantation .....         | 255 |
| The People's Rights in Western Forests..... | 257 |
| Raging Forest Fires in Northwest .....      | 258 |
| Paying Our Debts with Scenery.....          | 259 |
| Two Sides of the Boundary.....              | 261 |
| Great Forests of South America .....        | 264 |
| The Ned Definition of Forestry .....        | 267 |
| Canada's Forests as an Imperial Asset ..... | 270 |



3

4

BRITISH COLUMBIA'S INLAND WATERS.

- 1. Jones Lake looking North.
- 2. Jones Lake from Tunnel Pass.
- 3. Bute Inlet, Showing Mt. Superb, 8,000 ft.
- 4. Stamp River Falls.



(Courtesy Dominion Water Powers Branch)

- 1. Irene Pool, Campbell River, B.C.
- 2. Elk Falls, Campbell River, B.C.

- 3. Chehalis Lake, B.C.
- 4. Stamp River Falls, B.C.



## Do You Require More Capital?

For ten years, Royal Securities Corporation has been associated with the development and financing of Canada's most successful pulp and paper enterprises. Among them are:

*Abitibi Power and Paper Company.  
Brompton Pulp and Paper Company.  
Mattagami Pulp and Paper Company.  
Price Bros. and Company.  
Riordon Pulp and Paper Company.  
Fraser Companies, Limited.*

Do you desire to pay off floating indebtedness; increase your plant capacity; or acquire additional properties? If so, why not let us suggest ways of financing your requirements? Our Engineering and Statistical Departments are at your disposal.

## Royal Securities Corporation L i m i t e d

164 St. James St.,  
MONTREAL

58 King St. West,  
TORONTO

# Canadian Forestry Journal

VOL. XV.

OTTAWA, CANADA, JULY, 1919.

No. 7.

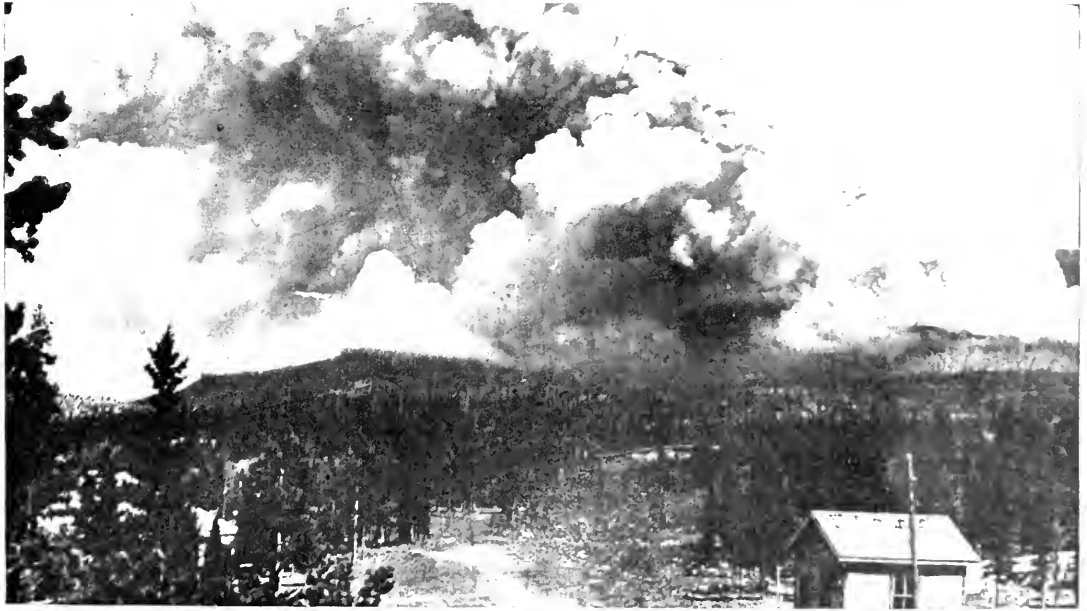

A forest fire at Nordegg, Alberta, caused by sparks from chimney of shack.  
Photograph by kindness of J. S. Fullerton.

FACULTY OF FORESTRY

AUG 5 1919

UNIVERSITY OF TORONTO

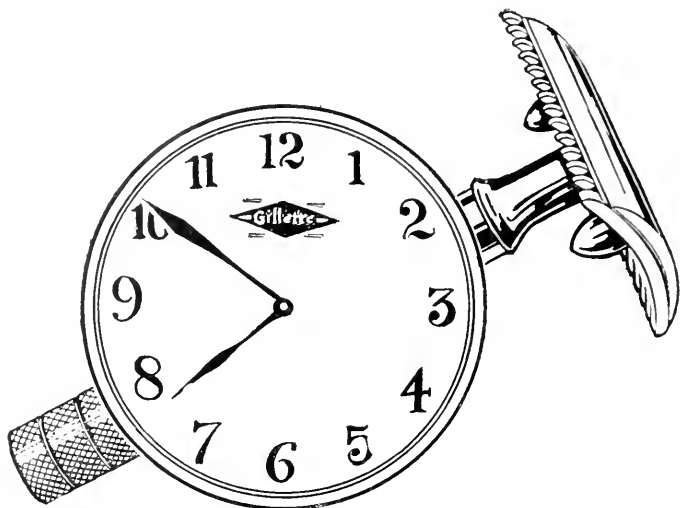

## Save 10 Minutes a Day

How long does it take you to shave? You can reduce the time to 5 minutes with a Gillette Safety Razor, and every morning enjoy the coolest, cleanest and most satisfactory shave you could wish for.

After all, it is the **QUALITY** of the shave, rather than the speed that is all important, and while we could go on to show what a saving of ten minutes a day can mean to a busy man, we prefer to emphasize the opportunity for **DAILY** shaving that has helped so many men to attain success.



# GILLETTE

## Safety Razor

MADE IN

CANADA



KNOWN THE

WORLD OVER

No Stropping—No Honing; no scraping or chafing; no intricate parts to keep clean. The keen Gillette Blade, used with the angle stroke, “slips” off the beard and leaves the skin smooth and comfortable.

*Sold by jewelers, druggists and hardware dealers at*

### \$5.00 The Set





13th Street, Brandon, Manitoba, showing a handsome arrangement of Manitoba Maples.  
A hedge of Caragana is visible on the inside of the walk.

## PLANTING SUITABLE SHADE TREES

*By F. E. Buck, Assistant Dominion Horticulturist,  
Central Experimental Farm, Ottawa.*

### An Authoritative Guide to Right Selections That Will Help the Planter of Memorial Trees.

Trees not less than architecture determine the beauty of the city. Trees proved certain factors in the life of cities which, from the sanitary standpoint, are invaluable. For example, the Commissioner of Health of the City of New York some years ago investigated the cause of the high death rate in that city and found that the extreme heat was one of the main causes. It was, therefore, resolved that "one of the most effective means for mitigating the intense heat of the summer months and diminishing the death rate amongst children is the cultivation of an adequate number of trees in the streets." The 81,000 trees in the City of Paris are an example of what can be done when tree planting is undertaken by the city as a business-like proposition.

The economic value of shade trees, both to the city and to the individual home, is also inestimable. A certain farm in Ontario possessed a fine avenue of pine trees leading to the

house. For some reason these trees were cut down and it is vouched by first-hand authority that when the farm was sold a few years later its value had depreciated \$5,000 owing to this one factor.

Trees, as one of Nature's finest products, which constitute an environment to our everyday life, are not appreciated as they should be. Remove the trees and place humanity under desert conditions and its life would be lowered in morale. It is reasonable to expect, therefore, that one of the ways many individuals will wish to commemorate the great war will be by planting trees. Fortunately the choice of suitable trees is large, but, owing to that very fact, sometimes trees of an unsuitable type are planted through ignorance. The qualities which a good street tree should possess are as follows:

1. **Hardiness**—especially in regard to the handicaps of city conditions.

## WHAT TO PLANT IN EASTERN CANADA

SUGAR or ROCK MAPLE  
NORWAY MAPLE  
RED MAPLE

AMERICAN ELM  
RED OAK  
MAIDEN HAIR TREE

## WHAT TO PLANT IN PRAIRIE PROVINCES

MANITOBA MAPLE  
RUSSIAN POPLAR  
BALSAM POPLAR  
GREEN ASH

ALSO IN SOUTH MANITOBA:  
ELM and BASSWOOD  
CANOE BIRCH  
NATIVE COTTONWOODS

2. **Straightness and symmetry.** One decrepit tree on a street may mar the whole effect.

3. **Freedom from the attacks of insects and fungous diseases.**

4. **Good foliage habits to give abundance of shade.**

5. **Cleanliness in habit of growth during flowering and fruiting stages.**

6. **Longevity.** Street trees must not be short-lived or easily broken by winds.

### *Six Good Trees for Eastern Provinces*

Sugar or Rock Maple (*Acer saccharum*).—A well known native tree, rather large, shady and upright in form. It thrives in most soils, except those of a heavy clay type. It makes a magnificent street tree, and one which is not troubled in Canada to any extent with fungous diseases, and does not require much pruning. In the autumn the leaves turn to brilliant shades of scarlet, orange and yellow. It has been found that it does not thrive in some American cities so well as the Norway Maple, as its foliage is sensitive to dust and smoke. This is the tree from which maple sugar is principally made.

Norway Maple (*Acer platanoides*).—This maple is a native of Europe. It is a fairly large and handsome tree with a compact, round head, not quite so large as our native maples. It is quite hardy in Canada, and is frequently used as a street tree. In the spring, the bright greenish, yellow flowers which come out with the bursting of the buds makes the tree a conspicuous object. The leaves are rather larger and darker than those of the native maples. In the autumn, it colors yellow and makes a pleasing contrast to the red and sugar maples.

In the eastern provinces of Canada the six trees described later on are at the top of the list for street planting. In the prairie provinces these trees are not hardy, consequently certain varieties which we look upon as too inferior for planting in eastern cities have to be used. The best of these are (1) the Manitoba Maple, (2) the Russian Poplar, and the Balsam Poplar, (3) the Green Ash. In the southern parts of Manitoba the Elm and Basswood succeed fairly well. The Canoe Birch and the native Cottonwood are also varieties which succeed well.

It is a tree which is very easily transplanted and and for this reason it is very much used for a street tree in many cities on this continent.

Red Maple (*Acer rubrum*).—Although not quite so desirable a street tree as the Rock Maple, it is a tree of upright form, with a comparatively narrow round head. It is also a native of Canada and has most of the good points of the maples. It is very conspicuous in early spring on account of its bright scarlet flowers, which come out before the leaves.

American Elm (*Ulmus americana*).—A large handsome tree particularly adapted for wide streets or avenues. It combines size and strength with beauty and grace of form, perhaps more than any other tree. It is one of the most rapid growing of all trees, will stand adverse conditions fairly well, and does well in many types of soil. No other tree in the whole list stands out so conspicuously as an all-round useful tree for street and avenue planting. Unfortunately, however, it is in some parts frequently troubled by insect enemies.

Red Oak (*Quercus rubra*).—The oaks are not so extensively planted as street and avenue

trees as they should be. They make the finest appearance and produce a very pleasing effect on a street. The Red Oak grows faster than any other oak, and will do well in any fairly good type of soil. It has a symmetrical round-topped crown and the glossy leaves are a dark dull green, turning orange to scarlet in the autumn. It is not so easy to transplant as some trees, but good nursery-grown specimens may be expected to succeed.

Maiden Hair Tree (*Ginkgo biloba*).—A tall and hardy tree from China with horizontal branches and curious leaves resembling the foliage of the maiden hair fern. It is a new and very promising tree for street use, and is entirely free from enemies of any kind. Although rather a slow grower it is very beautiful after it has obtained its full growth.

### *Choosing Trees for Parks and Estates*

In addition to these trees which are the most desirable for street planting, there are others which are better suited for planting around the home or in public parks and large estates. The most distinctive of these are:

Purple-leaved Norway Maple (*Acer platanoides Schwedleri*).—This is a variety of Maple which, on account of its purple foliage, makes a very handsome lawn tree. The leaves in the spring are bright purplish and crimson, which later in the summer turn to dark green.

Cut-leaved Silver Maple (*Acer Saccharinum Wieri*).—A beautiful weeping form of maple, with deeply cleft and divided leaves. The branches are very pendulous and generally reach the ground. A rapid-growing popular and handsome tree for planting around the home.

Horse Chestnut (*Aesculus Hippocastanum*).—The European or Horse Chestnut is sometimes planted on streets, but more fittingly for shade on lawns. It is rather a handsome tree with large palmate leaves, and produces white flowers in the spring. Of late years, however, it has been badly affected by a fungous disease and should be planted with caution.

Siberian Pea-Tree (*Caragana arborescens*).—This is a large-sized shrub or small tree producing abundance of yellow-pea-like flowers in the early spring. It is perfectly hardy, and makes a desirable lawn tree when a tree of limited size is required.

Mountain Ash Trees (*Pyrus*) (*sorbus*) (*Aucuparia*) and (*americana*).—*Aucuparia* is also known as the Rowan Tree. It produces a

symmetrical round-topped crown; the leaves are compound and attractive, and the flowers are also pretty; but it is chiefly desirable on account of the large clusters of bright red berries which are very showy in the late summer and fall. A weeping variety is also to be had of this tree which is very effective when planted on the lawn. *Americana* is the native species and although not as large a grower is as desirable for Canadian conditions as the European species. It is more variable in form.

American Larch (*Larix laricina*).—The Larch is one of the deciduous cone-bearers. It grows into a handsome pyramidal tree with a very light and graceful appearance. It does well in swampy lands, and makes a beautiful lawn tree, but is somewhat difficult to transplant except when quite young.

Flowering Crab Apples (*Malus*, species and varieties).—The Flowering Crab Apples, of which there are several varieties, are the showiest of spring-flowering ornamental trees. They are hardy and do well in most soils. Bechtel's double-flowering crab, producing abundance of small rose-like pink flowers, fragrant and beautifully double, is one of the best. Other good varieties are *floribunda Parkmani* and *f. Scheideckeri*.

Laurel-Leaved Willow (*Salix petandra* or *laurifolia*).—A medium sized tree of compact habit with dark green and shining medium-sized leaves which gives the tree a particularly clean and fresh-looking appearance. One of the best willows for ornamental planting, quite hardy and rapid growing.

## *Plant One Species to a Street*

It is of considerable importance that the systematic planting of one variety of a tree to a street should be encouraged. Nothing is so distressing from the aesthetic standpoint as the indiscriminate planting of several varieties on the same street, and especially when they are planted without regard to regular intervals between the trees themselves and the property line. A good example of a well-planted street, such for

instance as Clemow avenue, in the City of Ottawa, makes a lasting impression upon the mind of the visitors. Now that the war is over and trees are to be planted as memorial avenues or individual specimens, it is particularly desirable to call attention to these few hints relating to suitable varieties and their value in the beautification of the home or city.

## BRITISH COLUMBIA FIRE RECORD

The following telegram was received by the Canadian Forestry Journal from the Chief Forester of British Columbia:

**July 15, 1919.**

**"Situation in the interior and southerly Brit-**

**ish Columbia hazardous. On the coast conditions are fairly safe. The number of fires to date is 170. The damage so far is exceedingly light.**

**FOREST BRANCH."**

## B. C. MUNICIPALITIES ARE SUPREME

The Canadian Forestry Journal has received the following letter from the Department of the Attorney General of British Columbia, giving the status of municipalities in regulating the trimming of shade trees:

"Municipalities in this province have the right to regulate public utility companies, and to authorize the use of the public highways by late (notwithstanding anything contained in any such companies. They have the right to regulate (special or private act) the placing of poles, wires, etc. This would carry with it the power to protect shade or ornamental trees. Outside of municipalities the private acts incorporating public utility companies sometimes contain provisions reserving to the Minister of Public Works the right to regulate the placing of poles and wires."

## MEXICO STARTS FORESTRY.

In order that a scientific knowledge of reforestry and the protection of existing forests of the country may be obtained, the Mexican Government has established a National Forestry School at Coyoacan, Federal District. The course of instruction will cover a period of three years. The students come from nearly all the states and the school was opened on March 1 with a large attendance. The forest areas of Mexico are very large, but up to this time no scientific regulations or knowledge have been applied to the cutting of the timber. The government plans also to reforest the more barren sections of the country as rapidly as the work can be carried on.

## TRIMMING AND RE-TRIMMING ROADSIDE TREES

The Canadian Forestry Association is gathering evidence as to the practice of public utilities bodies in trimming trees so as to convenience their wires. An important point is brought up in a letter from Mr. Thomas Rowley, president of the Erie Co-Operative Company of Leamington, Ontario, who protests strongly against what he claims to be the unnecessary hacking of valued trees. Says Mr. Rowley:

"These trees were trimmed by the Essex Light and Power Company, and we see no reason why they should again be trimmed. We may be dense on this power and light question, but we fail to see why it is necessary to cut ten feet below the wire, which the Hydro are doing. We claim that so long as there are no branches touching the wires, that is all that is necessary and I don't think we would object seriously to that much trimming being done. It does seem strange that in some cities and towns the councils compel the power and light companies to put their wires underground, while in the rural districts they will not even put up higher poles or arms on the poles to avoid cutting the shade trees.

"If the Hydro people can find any limbs on these trees that are actually touching the wires we would have no objections to their trimming any branch or twig found in that position, but we do absolutely, and I believe will strenuously oppose any idea of cutting any limb or branch of tree that is not actually touching the wire."

To Mr. Rowley's complaint, Mr. W. W. Pope, Secretary of the Hydro-Electric Power Commission wrote the Forestry Association in great detail giving the results of a special investigation in Mr. Rowley's vicinity. In part Mr. Pope says:

### The Hydro-Electric Reply:

"One of the most serious difficulties in an electric line are the limbs overhanging the wires and these limbs breaking and falling on the wires, thus doing damage, not only to the service but oftentimes to property and persons.

"About a year ago, shortly before the taking over of the line by the Commission, a limb broke and parted a wire, the live end falling on a wire fence. A cat got into trouble with this and a Mrs. Mitchell went out to relieve the cat and in so doing was killed. There were several other accidents in this district caused by limbs falling on the wires and breaking them.

"All of this, you will readily understand, has to be taken care of and the cause of the trouble removed and the line made fairly safe.

"As to the trimming of trees whose limbs do not touch the wires. While the limbs might clear the wires under ordinary circumstances and conditions, directly there is a sleet, snow or windstorm, these limbs are bent toward the wires and entirely spoil the working of the line.

"The ten-foot clearance has been maintained throughout the Hydro's operations. Six feet was at first tried, but this was not sufficient. The clearance was then increased to eight feet and the Commission still had serious trouble and were compelled to make the clearance ten feet.

"As to high poles. That again is impossible as the cost of these poles would be prohibitive and it would only be a matter of time until the trees grew to the height of the poles and they would only require to be cut later on."

## EYE PROTECTORS FOR LOOKOUTS.

A United States Forest Service ranger has devised an eye protector for the use of lookouts. The device is simple. It is made of cardboard, painted black, fitting over the eyes, and has a long horizontal opening lined with narrow strips which prevent the entrance of light from the sides, also from above and below. A test will be made by several lookouts. The ranger states that his device will successfully protect the eyes against the bright glare in the atmosphere at high elevations.

## SURVEY IN FRASER VALLEY.

The Dominion Forestry Department will be asked to make a survey of the lower Fraser Valley for timber suitable for pulp and paper making. This was the decision of the Greater Vancouver and Lower Mainland Bureau of the Board of Trade. Considerable discussion had taken place at previous meetings regarding the possibilities offered in the valley for a paper plant, but it was thought advisable before any definite action was taken toward interesting capital in the matter to have authentic information available regarding the supply of timber.

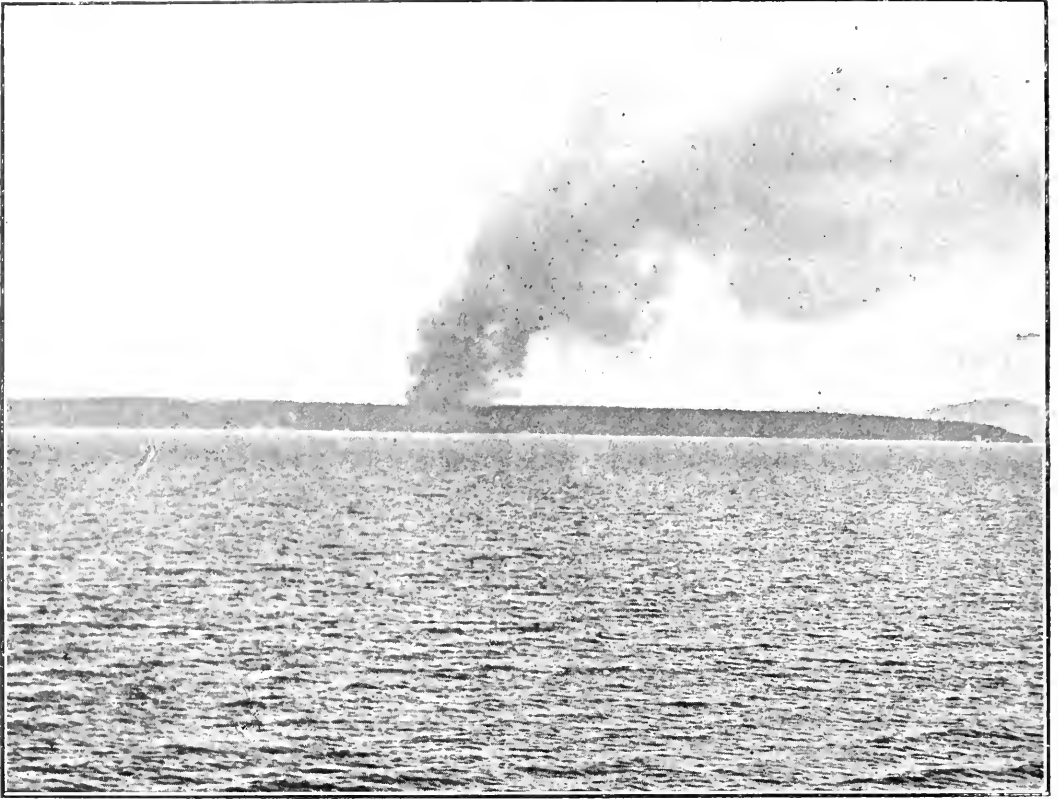

A unique picture of the commencement of a forest fire on Campbell River, B.C. Picture taken on deck of a steamer and herewith published by courtesy of the Pacific Coast Lumberman.

## TO CHANGE QUEBEC'S CUTTING REGULATIONS

*(Resolution passed by Woodlands Section of Canadian Pulp and Paper Association, June 25, 1919)*

"Resolved, that in the opinion of this meeting certain changes in the regulations of lands and forests governing the cutting of timber on Crown Lands are essential to the preservation and perpetuation of the forests, and it is respectfully requested that the executive committee of the Pulp and Paper Association appoint a committee to co-operate with the existing committee of the Province of Quebec Limit Holders' Association in waiting upon the Government with a view to urging upon it the necessity of an early revision of these regulations to meet present day conditions.

"Resolved, that this meeting takes the opportunity of expressing its gratitude to the Government of the Province of Quebec, and the Hon. Jules Allard, Minister of Lands and Forests, for the invaluable work in organizing the preservation and perpetuation of the forests in this province, and in view of the vital nature of this organization in the interests of the future welfare of this province that it is urged by this meeting on the Government, to preserve its present status in order to insure the various problems being brought to a satisfactory conclusion."

## LINEMEN AND SHADE TREE SLAUGHTER

From information acquired by the Canadian Forestry Journal shade tree owners in Eastern Canada are by no means as happily placed in their legal rights as those of British Columbia or many of the States of the American Union. In British Columbia, the municipality is supreme in regulating the tree trimming by electrical transmission corporations. In Pennsylvania, no lineman dare touch a hand to a shade tree whether in a city or the open country until permission has been granted by municipal authority. No state or federal charter has priority in such matters. This is quite a common condition in the New England States.

In Ontario however recent powers acquired by the Hydro-Electric Power Commission give its tree trimming orders priority over any claims of private tree owners or protests of municipalities. The Forestry Journal judging by its correspondence with the Commission, does not believe that the legal authority in this matter will be used ruthlessly. Indeed, the Commission appears to have taken pains to follow a policy of compromise and conciliation. At the same time, the Journal is convinced that damage to city and rural shade trees has proceeded far beyond the necessities of efficient electrical transmission and telephone operation. It is beyond question that

unless shade tree owners place a high value upon their property and insist upon the minimum degree of trimming, the beauties of roadsides and town streets are sure to suffer. One difficulty has been that not one municipality in fifty has considered the care of its trees as more than a side line of the county or town engineer. When a dispute arises, the power or telephone company is confronted by one or two individual owners, without organized backing and lacking sometimes in skilled judgment. If county and town councils regarded their shade trees as a really vital asset and placed their care in the hands of a skilled individual or even a committee, there is little reason to doubt that far fewer complaints would be received about the aggressions of linemen. The Canadian Forestry Association intends to develop this question of shade tree preservation and invites expression of opinion by tree owners and others.

In the last issue of the Journal the point was raised whether the present compensation offered by public utilities bodies was at all adequate and whether a higher rate would not decrease the extent of destruction. There follows an article on this subject for which we are indebted to "American Forestry".

## THE CASH VALUE OF SHADE TREES

By *W. W. Colton, City Forester of Newton, Mass., U.S.A.*



### How to Estimate Compensation for Ruined Trees.—One Dollar an Inch of Basal Area.



How are we to determine the value of our individual shade trees?

It is generally admitted that shade trees are valuable not only from an economic standpoint, but also from their aesthetic, historic and physical properties, but as my purpose is to show that there must be some definite method of determining their value, I am going to consider only the economic value.

The development of a street requires the removal of a tree at a certain point. Mr. A. says he wouldn't have that tree removed for \$1,000.

Would it damage his property to that extent? Would he pay that amount for replacing it? On what does he base his estimate of value?

A private corporation or individual damages a tree in such a manner that it dies. Mr. B. brings suit and claims damages of \$500 or \$1,000. The court allows him perhaps (?) \$150.

A city or town has a row of trees killed by gas. The gas company is sued, and here again the court awards an arbitrary figure of perhaps \$100 per tree, doubtless altogether regardless

of size, species, or condition. What method is used in determining these valuations? Up to the present time there have been a number of methods used.

### \$500 for a Single Tree.

First, the arbitrary method; as for instance, in Massachusetts, where a State law formerly gave the court the privilege of placing a fine of not less than \$5, nor more than \$150, on a person found guilty of destroying a tree. This left it optional with the judge as to how much it should be. In New York State the court has established a record by handing down a verdict of \$500 apiece for the destruction of a tree by a construction company. In some cases an arbitrary value has been placed on the tree by means of its diameter, as for instance, \$2.00 per inch; that is, a tree 18 inches in diameter would be worth \$36.00.

Second, the replacement value, under which would come such cases as are settled on a basis of the cost of replacement.

Third, is the method of placing an arbitrary value per square inch of basal area taken at breast height, or  $4\frac{1}{2}$  feet from the ground. The usual figure used in this case is \$1.00. This is used principally because it is easy to figure with. In this case a tree 18 inches in diameter having a basal area of 254.47 square inches, would be considered worth \$254.47. This is rather different from the first example and obviously quite as much too large, for an average case, as the first is too small.

### The Parker Method.

The fourth, called the Parker method, is a variation of the above. In this case \$1.00 per square inch of basal area is allowed, but a reduction is made for position, species, trunk, condition, top condition, and general desirability, scenic value, etc. Twenty per cent is allowed for each of five heads when perfect. An optional reduction is made for defects and the resultant figures added together and multiplied into the basal area valuation. This is by far the best of any system that has yet been advocated. It, however, has certain defects, as it tends to give too high a value to certain species.

For a number of years I have given much attention to a study of the valuation of trees and am convinced that some standard of valuation should be adopted.

In analyzing the various methods now in use it seems that the most accurate way of estimating the value of a tree is by means of its basal

area, as this is the best graphic indication of the tree's size of crown, which, after all, is the real valuable part of the shade tree.

No accurate basal area factor can be derived that will be equally valuable for all species. It becomes apparent then that we must first obtain a value per square inch for basal area that has some definite foundation, and then arrange a sliding scale of deduction factors for various species, according to their specie value, that is, rate of growth and resistance to insects, disease, climate and present physical condition.

To obtain the first, the sugar maple was selected as a standard species, because it has been more commonly planted for the past fifty years than any other tree, and we have more available data in regard to it. In order to reach a definite figure to apply to the basal area, we based our calculations on the amount of money invested in growing a tree to a diameter that would produce that basal area. This includes the original cost of the tree, its planting and maintenance. By using the best available figures for a sugar maple, we found that the average value per square inch of basal area at the end of fifty years is  $64\frac{1}{2}$  cents. This is the value of an ideal tree under perfect conditions.

### Reduction Factors.

The next step was to obtain a scale of reduction factors for species and condition. It is evident that by the use of this method the value placed on a 12-inch fast growing tree would be the same as on a 12-inch slow growing tree, whereas the actual value of the slow grown tree would be much more. For instance, from a standpoint of interest on investment and maintenance, a 12-inch beech would be worth very much more than a 12-inch poplar.

To obtain a deduction factor, the most common species were divided into five classes, according to their rate of growth, and a proportional deduction made for each class.

As all trees are not equally valuable on account of their susceptibility to insects and diseases, they were again divided into five classes and the same deductions made.

One more reduction factor was necessary to complete the list, that for the present physical condition of the tree. To obtain this a reduction was made for the condition of the top and trunk, and the resulting figure used as the factor.

By applying the factors, obtained from the above deductions, to all common species of shade trees, we found that the sugar maple was



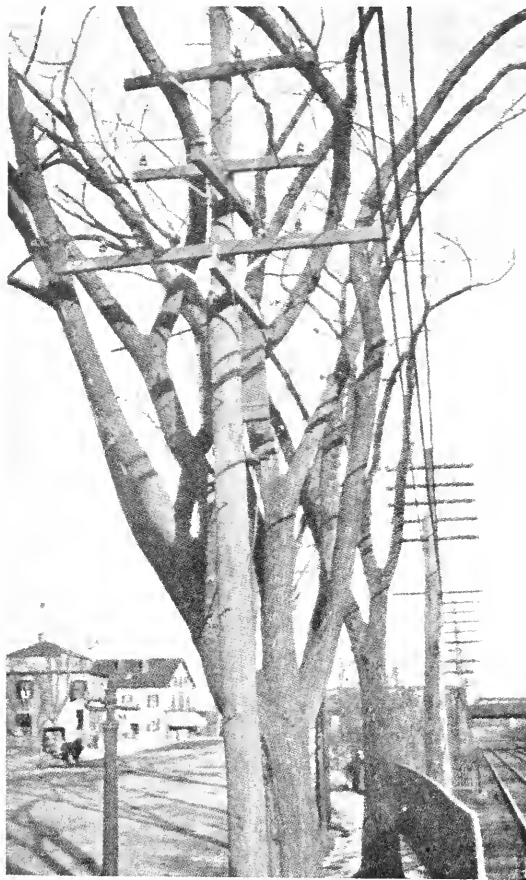

WHAT IS YOUR PRICE ON THIS DAMAGED  
ELM?

City Forester Colton says it is worth \$142.55, and if uninjured by high tension wires would be worth \$199.56.

15 per cent below a perfect tree. Therefore, if the value of a sugar maple was 64½ cents per square inch of cross-section, the value of a perfect tree, or a standard value, would be 75 cents.

A table has been prepared, using 75 cents as the value per square inch of basal area for a perfect tree, and showing the proper deduction factors for all species of shade trees. This table is being used by this office in obtaining values, and has been found very satisfactory.

There is one point in the discussion of the value of a shade tree which has not been touched upon in this article, and that is "location". Viewed from some angles, this is a very important point. From the fact, however, that there is such a chance for diversity of opinion as to the proper and improper location of a shade tree, I have purposely neglected to take

this into consideration in my factors for deductions. The opportunities for deductions of all kinds are so great, and the possibility of arriving at any definite figure for abatement so uncertain, that it has seemed best to eliminate this factor entirely. It is my belief that this deduction can safely be neglected, unless the tree is most obviously out of its proper location. If, as stated above, there can be no question about its improper location, then the party or parties judging the value should make some arbitrary reduction from the value placed on the tree by the prepared tables.

As a concrete example for the usefulness of some set value for shade trees, we have established an approximate value for all the street trees of Newton, Massachusetts.

In the summary of data gathered from the shade tree census, we have grouped all our trees by species, diameter classes and conditions. For instance: sugar maple, 1/6-inch; 7/12-inch, etc., and either Good, Fair or Poor condition.

| Species.                | No. of trees. | Value.       |
|-------------------------|---------------|--------------|
| White Maple -----       | 355           | 40,206.00    |
| Sugar Maple -----       | 6,531         | \$612,851.00 |
| American Elm -----      | 2,471         | 417,867.00   |
| Norway Maple -----      | 1,130         | 98,737.00    |
| White Ash -----         | 382           | 85,112.00    |
| Red Maple -----         | 480           | 72,324.00    |
| All other species ----- | 1,228         | 189,505.00   |

Total valuation ----- 12,577 \$1,516,602.00

To obtain an approximate value for these, we have eliminated those classed as Poor altogether, and then based our calculations on an average valuation for trees in each diameter class. The average value was then reduced for species and the resulting value applied to the number of Good and Fair trees of each species in each diameter class, with the above result.

This is discounting entirely 2,320 trees classed as Poor, which would, of course, have some value.

It can readily be seen that with a permanent value established, the above figures are of unmistakable assistance to a city forester or arborist in convincing the city government or town fathers that it is a good investment for them to appropriate a sufficient sum of money to properly care for these trees.

### PHOTOGRAPHS WANTED.

The Canadian Forestry Journal will pay \$1.50 each for unusual photographs of shade trees or of wild life.

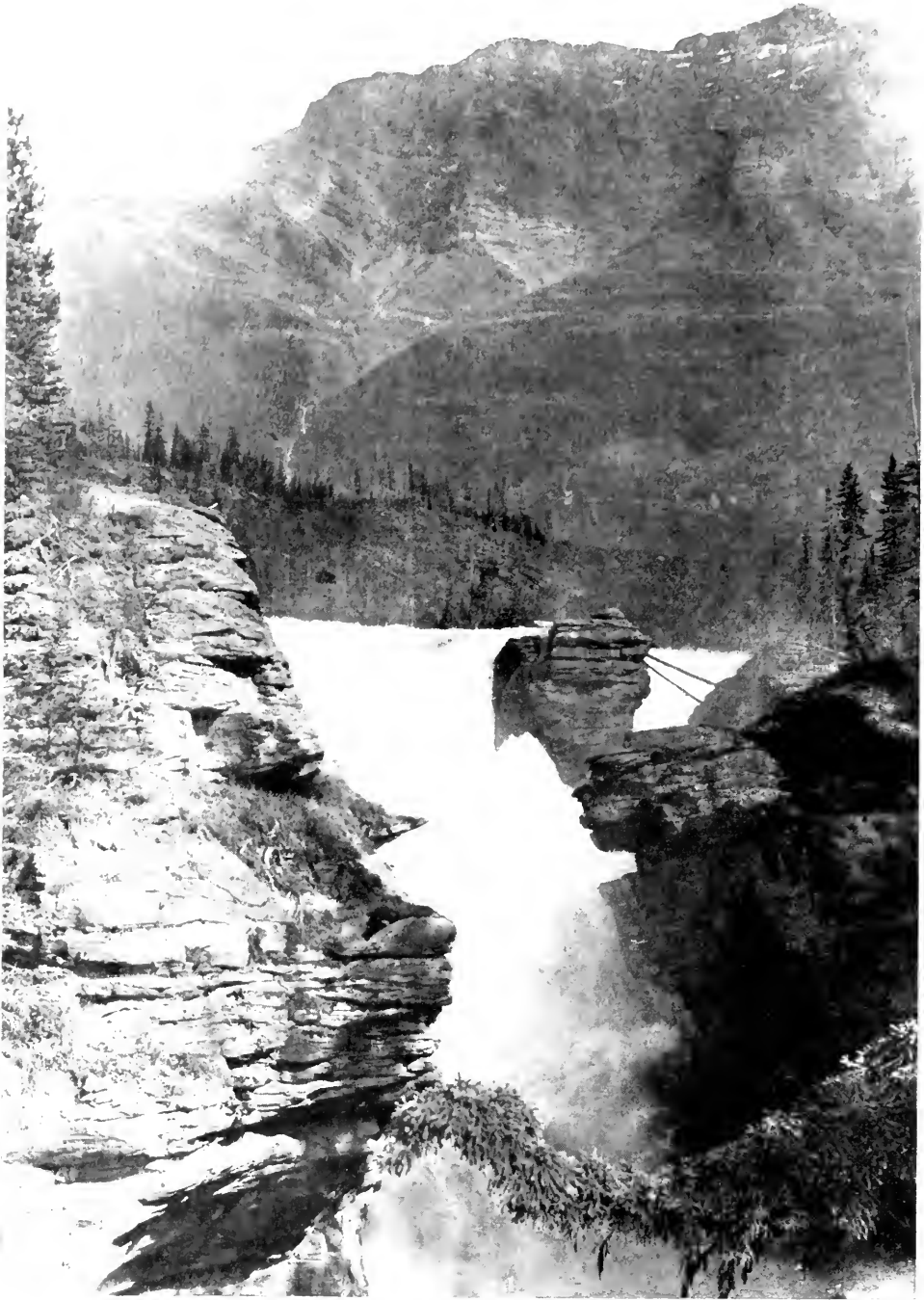

In the depths of Athabasca Canyon, B.C.

## PUBLIC NECESSITY AND PRIVATE RIGHTS

### Canada Concerned in Principles Underlying American Efforts to Establish National Forest Policy.

Great interest and some alarm has been created in the United States by a proposal of Henry S. Graves, Chief Forester, that through Federal and State co-operation a national forest policy should be designed sufficient to place the nation's timber resources on a basis of sustained yield. The point of maximum friction, obviously, is that of proposed state interference with the handling of privately owned woodlands. Mr. Graves' tentative plan declines to allow the private owner any compensation for expenses incurred in carrying out a programme of constructive forestry. He allows compensation, however, in special cases where the timber must be kept standing for watershed protection, or maintained for a long period as a reserve, or destroyed as a preventive of insect depredations.

To all of which Mr. R. S. Kellogg, a former member of the Forest Service and now secretary of the Newsprint Service Bureau, makes an emphatic reply of which this is a part:

#### "Forestry Must Pay."

"It seems to me that the time has come when the professional foresters of the United States should be frank enough to acknowledge what those who have had practical experience saw long ago, namely, that the growing of large sized timber of ordinary commercial species is an operation too long in time, too hazardous in risk, and too low in rate of return to attract private capital, and that an attempt, national or state, to force private capital by legal enactment to engage in undertakings that are not profitable is doomed to failure. Forestry must be economically sound or it will not succeed."

Mr. Kellogg then suggests taking a timber census and land classification, the wider purchase of cut-over lands, the acquisition of a reserve supply of timber in the West, and better fire protection. In general, however, Mr. Kellogg advises against any mandatory action respecting management of private woodlands which, it is important to note, constitute four-fifths of the United States timber assets.

#### The Feeling in Canada.

Mr. Kellogg's criticism is not unlike what is

commonly heard in Canada in respect to any state interference with old-established logging methods that in certain places and in certain particulars may be the very antidote of conservation. In Canada, however, one finds progressive lumbermen and paper manufacturers openly critical of such ill-working blanket regulations as is involved in the diameter limit and not at all unwilling to adopt improved methods if only they are made mandatory and at least province-wide. Local forestry, patchy conservation, has taken no hold whatever in Canada, nor can it get far anywhere.

Many Canadians have said, after Mr. Kellogg's manner, "Forestry must be economically sound to succeed. Forestry must pay." This is open to a dozen interpretations. Is a cutting system that makes a tidy fortune for a jobber and yet so exhausts a timber tract as to close down an industrial town, economically sound? It is sound indeed, within the limited sense of the jobber's economy. It is quite unsound, and politically crazy, as a community enterprise. Whose economic soundness is to receive first consideration? Apparently, the head of the United States Forest Service makes the security of the state his starting point. No doubt Mr. Kellogg also would subscribe to that. The rest is a matter of method. Mr. Graves inclines towards legislative compulsion, believing that twenty years of educational method have not affected conditions on private-owned lands and that while logging methods may be uncomfortably regulated, the changed order will be uniform, and therefore acceptable.

#### Agreed on Need of Survey.

Mr. Kellogg calls for a preliminary timber survey. In all probability there is no better way of reaching a common ground for accurate discussion, whether as concerns United States or Canadian forest management.

One cannot fail to appreciate the intricacies of any American effort to govern the conversion of timber values on lands that have been completely alienated from public control. Many of the title deeds have been transferred again and again. To impose regulations deferring the cut-

ting of part of the timber thereon is, of course, to cut off a portion of the private profit in order to serve public necessity. Canadians may again

congratulate themselves that by the good sense of successive governments less than ten per cent of the forest area of the Dominion has passed out of state control.

## TECHNICAL MEN WANTED IN THE WOODS

While forestry advocates generally acknowledge the cordial spirit and ready aid of Canadian lumber trade journals which have time and again opened their pages to discussions of better forest management, one or two of the United States lumber trade publications appear to get entertainment from pot-shooting technical foresters and the practice of scientific forestry. Not so, however, with the "Timberman," of Portland, Oregon, which in place of hiding its head in the sand of "We should worry", demands an awakening of all timber operators to the need of applying technical knowledge to cutting operations. The following is from a recent issue of the "Timberman":

"Perhaps no clearer statement of the needs of trained men in the lumber industry has been presented than that issued by the Oregon Agricultural College of Corvallis, Ore., in announcing its courses in Forestry:

An industry without leadership is as surely doomed as a rudderless ship. Of all the industries on the Pacific Coast the timber and lumber business is richest in exclusive worth. One-fifth of all the standing timber of the country is in Oregon. The harvesting of this great wealth so as to conserve essential values and serve the public to best advantage, is a task for thoughtful men who are specialists in handling forest products. These men must have the aid of modern science and modern engineering methods. Hence they must have training in a technical school of forestry.

The war crisis revealed to the world how essential to the nation is the timber wealth of the Pacific Coast. It revealed also the necessity of a far-seeing and consistent effort to conserve our forests as a permanent resource at the same time that we harvest the timber that is ripe and accessible for market. The activities in shipbuilding and the revived interest in private construction, as well as the extensive programmes for public construction that have been commenced throughout the country, all give assurance of great activity in the lumber business. Hence the need of live and resourceful youths to go out from

the School of Forestry as future leaders of approved principles of harvesting, manufacturing and marketing timber products. Such men are few and far between in practical lumbering operations to-day; since forestry is comparatively new in technical education. They will be needed, however, and demanded with greater emphasis, from year to year. The call is already insistent. The largest and most efficient companies are the ones who are keenest for employing technically trained men. They recognize the permanent worth of scientific leadership.

"The Timberman has always contended that the practice of scientific forestry methods would develop through the graduates of logging engineering schools where the young men, after engaging in operations, gradually will blend their theoretical ideals with those of the more practical side of lumbering.

The men who served in the Forestry regiments in France have learned an appreciation for timber conservation and its maximum use which will be exemplified in their future life's work, and in time will be reflected in the forest policies of the country at large."

### MACHINES TO FELL TREES.

(*American Lumberman*)

The American Lumberman has private information to the effect that an American patent has been applied for (and will be followed by foreign patent applications) upon a new type of tree felling machine which uses an original design of chain saw as the cutting tool. It is driven by a small gasoline engine. The main frame, which rests upon the ground, is provided at one end with wheels so that it may be readily moved, and a sliding carriage operates upon it which carries both the saw and engine and may be moved forward toward the tree which is to be felled. The device appears to be mechanically very well designed, and while in its original design it is adapted only to tree felling, a combination design adapted also to cross cutting could be very readily worked out.



Photo by F. Johansen.

*Where Canada's Forest Stops Growing.*

On the Coppermine River, North West Territories, in "Arctic Canada". Many of the trees have been partly killed by forest insects.

## THE FOREST'S LOSING FIGHT IN ARCTIC CANADA

*By Frits Johansen, Geological Survey, Ottawa.*

### Intense Cold of Changing Climate Has Killed Young Trees—Remainder an Easy Prey to Insects.

The general outline of the northern limit for white spruce in Canada has long been known. It is found in the greater part of Ungava (Labrador Peninsula) and comes fairly close to the west side of James and Hudson Bays. North of Fort Churchill the line runs inland and follows roughly the Aylmer Lake-Coppermine River watersheds and makes a big bend north of Great Bear Lake to the Mackenzie River delta. North of this lake, however, many of the rivers which flow into Hudson Bay or the Arctic Ocean have spruce growth along their courses and thus carry the line of trees farther north. Much additional information is needed upon this point, and hardly anything general can be said about it except that

the trees are scarcer and more stunted the nearer one comes to the river mouths or as one goes higher up their slopes, and (to a less degree), according to latitude. The character of each river is important, whether it runs through an open valley or lies deeper down with steep sides—the amount of protection from the sweeping winds being the deciding factor.

In the region in question (south of Coronation Gulf) the observations embodied here were made by the Southern Party of the Canadian Arctic Expedition; but it should naturally not be forgotten that several other expeditions and explorers investigated the country earlier and have given us our main information about it. I refer to the accounts of Samuel Hearne, Sir John

Franklin and Dr. Richardson's expeditions, besides the various explorers and travellers who more recently (20th century) have used the Coppermine River as a kind of highway to or from the Arctic Ocean. Nowhere, however, is the northern limit of the white spruce treated from an ecological point of view, or in any detail at each place visited.

#### Grow Only With Protection.

With the exception of the Coppermine River and a small river (Naparktoktuak) about ten miles east of it, no white spruce is found on the other river valleys further east or first when one reaches their upper courses. According to Dr. R. M. Anderson the spruce growth in the small, more unprotected Naparkoktuak River (its name is Eskimo for spruce), is very stunted (below six feet) and scattered, only a little grove of trees being found here and there; but the trees reach to within a dozen miles of the Arctic coast. No observations were made in this river as to whether the trees were attacked by forest insects (no larger dead trees were observed) or not; but it is not likely to have been the case to any extent, the trees being too small and without connection with more extensive spruce growths; barren grounds intervening.

It is about  $67-1/2^{\circ}$  Lat. n. that the most northern spruce trees along the river are found. The outposts are represented by about a dozen dwarfed trees which grow in scattered formation up the steep side of the west bank. I only saw them at a distance, but they seemed not to exceed four feet in height.

From here on, as one travels up the river, the trees increase in number and height and are found here and there on the banks; they are especially numerous and well developed in the mouths of small creeks—valleys joining the river, where they have some protection. We camped in a fair grove of trees on the east side of the river (near Escape Rapids) at a small creek-tributary. The best developed trees (up to about a dozen feet high) were found on a small flat at the mouth of the creek. As one went away from the creek or higher up the slope the growth became more scattered as also the trees smaller, and finally none at all were found. But old stumps and dead trunks of these trees showed that the spruce growth formerly attained a considerable size and had a more extended range up the slopes of this creek. As we continued further up the river on the east side the growths of trees became more numerous, and a larger creek near Sandstone

Rapids, where I stayed four or five days, afforded good opportunities for observations on the spruce trees here.

The west bank of the Coppermine River at the mouth of this creek is quite barren. On the east bank of the river the spruce growth is best developed (as a real small forest of high trees) in a depression south of and on top of a higher rounded cliff at the narrow place of the river a little north of the creek. The spruce vegetation is also well developed on a similar cliff-exposure on the east bank of the river a little south of the creek while the trees at the mouth of the creek are represented by a few scattered clusters and rather dwarfed. Following up this creek on the east bank of the river a grove of fair-sized trees are found in a protected pocket on the north side of the creek, but otherwise the growth gets more and more scattered and the trees dwarfed, until they quite disappear on top of the slopes. The biggest spruce tree I saw in this creek measured 59 inches in circumference about three feet from the ground, and it was 20 to 30 feet high. All the large trees had many dead branches among the living ones; and most of them were to a lesser or larger degree attacked by forest insects. Scattered over the region occupied by the living trees, and for a considerable distance outside of these were many dead trees and stumps standing, mostly deprived of their bark and of a still larger size than most of the living ones. They practically all showed signs of having been killed by forest insects.

From what I saw of the growth of white spruce on the lower Coppermine River it is evident that the occurrence of the trees depends principally upon the amount of protection available from the sweeping winter winds. As the winds mostly come from the north the spruce trees are found almost exclusively and attain their greatest development in localities protected from that direction, where also they benefit most from the warm rays of the sun. The kind of soil present at the various places of growth is much less important. I have seen real forests growing on almost the bare cliffs, while no trees at all were found on the exposed tundra.

#### Young Trees no Longer Thrive.

Another striking characteristic is the scarcity of very young spruce trees in this northern limit of their growth. Perhaps the intense cold and the sweeping wind in the winter time kills off most of the small seedlings which may have succeeded in taking root during the summer. This explanation is also indicated by an ex-

amination of the age of the various trees here; by counting the rings even the small and stunted trees were found to be under half a century old, while the largest trees would reach an age of almost 500 years.

I did not myself travel any further up the Coppermine River than around Sandstone Rapids, but from observations made by other members of the expedition it is clear, that even if the spruce growth gradually gets more extensive and the trees better developed, the characteristics (stunted growth on exposed places, many dead trees, etc.) remain the same.

Curiously enough seems the fact, that forest insects are principally responsible for the killing of the trees or tree parts on the lower Coppermine River, and have passed unnoticed by the various explorers and travellers who have visited the region from time to time; though they all comment upon the other characteristics of the spruce vegetation. A deterioration of the climate, coupled with destructive fires now and then, and the exposed position of the trees at a high latitude, have been given as reasons for their peculiar appearance in shape and growth. Now we have definite observations upon the spruce trees here; and remembering that the destructive forest insects in question do not attack dead trees, we may safely assume that casual wounds inflicted by the traveller's axe or a forest fire upon the living trees give the

forest insects an opportunity to increase the damage, and finally kill off the individual trees; and thus accomplish in a few years the same result which it will take a century or more to affect by the present slow deterioration of the climate only. It should also be remembered, that a forest fire is less destructive on places where the growth of trees is so scattered and the underbrush so little developed as is the case on the lower Coppermine River. The very isolation and exposure of the individual trees here make them ideal objects for attack by forest insects, which by living under the bark are less influenced by the shortness of the summer season.

#### REMOVED BY SPECIAL TRAIN.

After fighting for 24 hours forest fires which threatened to sweep the town, the inhabitants of Natal, B.C., were removed from the town in a special train, while a volunteer fire corps under Chief MacDougall extinguished blaze after blaze within the town itself until the fire in the immediate vicinity had spent itself. No serious casualties were reported. Forest fires were reported from many districts near, and some ranching property was threatened. A fire one mile east of Hosmer was confined to cut-over land, and the fire wardens have been successful so far in protecting valuable timber lands.



Photo by F. Johansen.

*In the Last Northerly Zone of Tree Growth.*

Camping among white spruce, near Sandstone Rapids, Coppermine River, N.W.T.

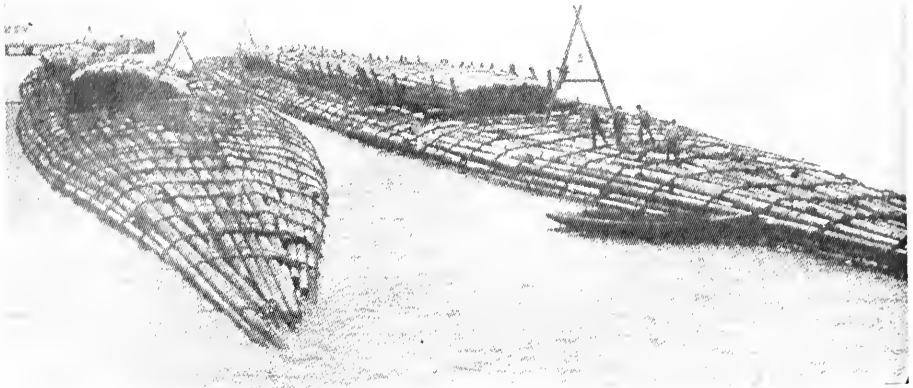

How Canada's timber may reach foreign markets in future, thereby ameliorating the shipping problem. Picture shows Benson log rafts moored in San Diego harbor after a journey of 1,200 miles by ocean from the Columbia River.

## PASSING OF THE BALSAM BUDWORM IN N. B.

*By John D. Tothill, in charge of Natural Control Investigations,  
Dominion Entomological Laboratory, Fredericton, N.B.*



### Shall We Have Another Outbreak?—Damage May Be Prevented by Allowing No Solid Stands of Fir.



We are frequently asked what effect will the present outbreak of the Spruce Budworm have upon the status of the tree more particularly affected, namely the Balsam Fir. The outbreak in question is practically confined to part of the New Brunswick forest and it is to this area that the following remarks will apply.

First of all, however, what is the Spruce Budworm? Many readers who have visited the New Brunswick woods during the past few years will know that most of the fir boughs cut in June and early July have not been fit for making up a bough bed. They have been filled with caterpillars which are those of the Spruce Budworm. Again some have seen in July areas of our forest having the appearance of being scorched as if by a light fire; this appearance has been caused by the budworm caterpillars eating away the new needles, the remnants of which have turned brown. Some again will remember the clouds of little moths that accumulated around

the arc lights of Fredericton and other cities toward the latter part of July in 1913 and 1914. The caterpillars of the boughs had become full fed and had turned into chrysalids and from the chrysalids had emerged the winged moths. The winter stage is less conspicuous. After pairing the female moth lays batches of green colored eggs on the needles of fir and spruce; the eggs hatch in August and the resulting caterpillars seek out a sheltered crevice in the bark; here they spin a silken case and spend the winter. In the following May the tiny caterpillars come out of their shelter and climb to the opening buds where they feed upon the new foliage. These tiny insects soon grow into the caterpillars of the boughs that we have already referred to.

#### **The Degrees of Injury.**

So much then for the nature of the insect. As to what it does we have already noted that its caterpillars destroy the tender foliage of fir



trees. In a general way it can be said that the fir trees defoliated in 1914 seemed quite vigorous in 1915; those defoliated in both 1914 and 1915 showed growth checks and a slight amount of top injury in 1916; those defoliated successively in 1914, 1915 and 1916 showed severe growth checks and also severe top injury in 1917, and a few of them were killed; while those defoliated in 1917 in addition to the preceding three years were nearly all killed.

The insect has now been on the rampage for five years and is at last decreasing in numbers. It has killed a very large proportion of the fir trees that are over twenty years of age, but has not effected very much the younger trees whose tops are still in partial shade; for the moths dislike laying eggs on trees whose tops do not pass through the forest roof. Neither has it effected very much any of the three species of spruce occurring in the province. So that while the damage done has been exceedingly heavy it has fortunately been confined almost wholly to fir of merchantable size.

#### Centuries Before Champlain.

One is often asked is the insect a new one. No, it is not a new one to the continent, but is a native and it probably occurred in New Brunswick for centuries before Champlain discovered the Saint John River in 1604. We have actual records of these outbreaks of this insect that have occurred in the State of Maine, and probably also in New Brunswick, during the past 110 years.

If history repeats itself, we are due to have another outbreak in twenty or thirty years, and judging from the preponderance of fir in the present reproduction the next outbreak is likely to be far more serious than any of its predecessors. Moreover another outbreak seems inevitable unless active measures are taken to prevent it.

#### How to Prevent Recurrence.

A study of conditions in the New Brunswick forest during the present outbreak has brought out the fact that the Budworm has gained no foothold in areas where the Balsam Fir exists in the primeval condition of a mixed growth. Another outbreak would evidently be prevented by so arranging cutting operations as to prevent the formation of solid stands of fir. Just how feasible it will be to prevent the undue production of fir is not yet clear. The problem however, is one that merits the most earnest consideration of those actually controlling the cutting operations, and upon its successful solution depends in no small measure the future success of the lumber industry in this province.

#### AERIAL PATROL DOES GOOD WORK.

Flying from March Field, Alessandro, Calif., an army airplane engaged in fire patrol work discovered a fire in the Waterman Canyon, not far from San Bernardino. A message giving the alarm was dropped in San Bernardino at once. Within a few minutes fifty fire-fighters were on the way to the scene of the fire. They arrived in ample time to prevent a destructive blaze.

There follow some recent notes on fire patrol work by the Air Service from several California aviation fields:

Exceedingly dry weather over California has caused increased vigilance of the aerial fire patrol and the watch from the observation balloon (United States Army School Arcadia staff) was maintained throughout the night.

Mather Field staff, Sacramento, Calif., during the week ending June 21, 1919, made 21 flights over the national forests, discovering four fires which were reported to the Forestry Service at Placerville Calif. The total mileage of the patrol was 3,000 and the patrol pilots were fifty-three hours in the air.

March Field staff, Alessandro, Calif.—Twenty-four trips were made, occupying thirty-eight hours, covering 2,500 miles.

Rockwell Field staff, San Diego, Calif.—Eight flights were made in twenty-six hours and twenty-six minutes, covering a distance of 2,115 miles.

E. T. Allen, secretary of the Western Forestry and Conservation Association, has long advocated the use of aircraft to spot fires on the north Pacific coast and in the Inland Empire. He recently urged that the aerial fire patrol work inaugurated in California be extended up the coast. The California flyers are patrolling regularly over a forested area covering about 6,000,000 acres. Estimated by Forest Service experts are that the work could be extended over 90,000,000 acres.

Aircraft are especially valuable for locating fires in deep canyons and valleys. Frequently the smoke from such fires does not reach the line of vision of the experts in lookout towers on high points until the blaze has had a chance to get a good start. While this form of fire protection always will be expensive, it fits in so well as one of the civil uses for the airplane and lighter-than-air craft and furnishes such excellent training for pilots and observers that it may be adopted as a permanent part of the work of the Air Service.

# A QUESTION FOR NEW BRUNSWICK!

*By Angus McLean, President, Bathurst Lumber Company,  
Bathurst, N.B.*

## Development of Pulp and Paper Industries is a Stimulant to New Employment and Closer Utilization.

### MR. McLEAN'S CONTENTIONS:

**Stamp out forest fires.**

**Encourage establishment of pulp and paper industries to utilize maximum values from the forest.**

**Reclaim waste lands for timber.**

**Discourage extravagant practices of sawmills.**

Bathurst, N.B., July 1, 1919.

Editor Canadian Forestry Journal,—I have a request from the Editor for a short letter touching on the forestry conditions in New Brunswick. I am, of course, more familiar with conditions prevailing on the north shore of the province, but conditions vary but very little in the whole of this province and they are also very similar to conditions prevailing in Nova Scotia.

In this country we are not subject to any serious forest fire hazard and with any kind of ordinary care we should completely abolish this hazard. This condition is due to the fact that we have a heavy precipitation here during the periods that are usually dangerous for fires. Then we invariably get early snows and they cover the ground in the woods usually up to the 1st of May and in the thick forests very often up to the early part of June. By that time the green undergrowth in the woods is up and covers the ground so that fires do not run. Our experience of ten years here has been so uniformly satisfactory in this respect that we are quite satisfied we are practically at the point where we will absolutely eliminate this hazard. We have had a few minor fires in our woodlands, but they have always been extinguished before much if any damage was done, so that our loss from bush fires covering this ten year period has been practically nil. What fires have taken place were invariably started by some settler burning up his slash without proper supervision. Our Minister of Crown Lands, Dr. Smith has taken the necessary and proper steps

to stop this hazard and regulate the burning of all slash in the future, and we are convinced he will succeed.

### Bog Lands.

Most of our woodlands have a thriving growth of young timber on them, but we have some areas of bog and burned-over territory which should be receiving attention and prepared to produce timber, as most of our lands are not fit for farming and are only suitable for growing trees. The bog lands ought to be drained and the old burned-over lands, of many years standing, put into shape that young trees could grow on them. This requires some attention from a practiced forester. Apart from these above-named lands our timber reproduces itself without any artificial effort whatever. Please remember that these burned-over areas are of long standing and they were largely caused by hunters who claimed they needed open areas in the forest in order to get game as the moose and deer could not be successfully hunted in the dense growth.

### More Careful Cutting.

Next and one of the most important matters is the cutting of timber. This, of course, is done under government regulations when cutting on Crown lands. There has, however, been very great loss caused in cutting timber in our forests here in the past, owing to the small trees cut in yarding and making roads being allowed to remain in the woods to rot and also when trees are felled too much timber is left at the stump in way of butting and large tops. Am quite sure fully one-quarter of the trees has been wasted in this way in the past. Of course in the ordinary course of lumbering for sawn lumber only, it is not feasible to take out the defective butts and small tops profitably, but these can all be used profitably in the pulp and paper industry and this is in the line our Provincial Government should devote some time to, and encourage these establishments in every possible way.

**"Appalling Waste."**

Next, the waste at the saw mills in New Brunswick and also in Nova Scotia is really appalling. Every mill in the land has either a steel incinerator or an open burner, into which thousands of cords of good material are being dumped and burned up annually, causing a serious loss of good raw material which should be utilized, and depriving many men of work to fit this material for the market. This is a great economic loss which should be very speedily corrected. In New Brunswick alone, hundreds of thousands of dollars are lost in this operation annually.

Another matter that is worthy of serious consideration is the manufacturing of our lumber and other products from wood into as near as possible the finished products at home. Too much unfinished raw material is being shipped out of the country on which needless cost is

entailed in the way of freight charges and our country is deprived of the expenditure of labor to convert.

Now to sum up, we must be satisfied with nothing less than absolute safety from fire in our forests.

Our waste and unproductive forest lands should be reclaimed and set to growing timber.

Our cutting should be so regulated that there would be no usable material whatever left in the woods when cutting is done.

Our waste in the saw milling eliminated until not even a grain of saw dust will be burned for naught. All material at the saw mills that is not usable in some form may be used as fuel to create power.

There are many other points I could touch upon, but this letter is already too lengthy.

Yours truly,

ANGUS McLEAN.

---

## TREE PLANTING WORK IN QUEBEC



---

Berthierville Now Has Four Million Seedlings—Laurentide Company Has Developed Successful Plantations.

---



One of the most valuable organizations in the Dominion for the promotion of actual conservation of forests is the Woodlands Section of the Canadian Pulp and Paper Association. How close to its problems the Woodlands Section keeps was well illustrated by the holding of a summer meeting at Berthierville, and Grand Mere, Quebec, on Wednesday and Thursday, June 25th and 26th. About seventy-five men identified with the wood-using industries of Ontario, Quebec and New Brunswick, together with Government Ministers and foresters spent a full day in constructive discussion of urgent problems and in estimating the possibilities of forest re-planting. Mr. Piche's nursery work at Berthierville is always interesting, but especially was it so when every point in its development was carefully drawn to the attention of the large visiting party. Mr. Piche, with the enthusiastic backing of his Minister, Hon. Jules Allard, has built up a stock of 4,000,000 seedlings and it is expected that shipments from two to three million plants annually will soon be possible. The product of the Berthierville nurseries may be

seen in all parts of Quebec, and the Government itself has done quite extensive work in planting up denuded lands. Not the least important section of the nursery area is the 25 acres laid out for experimental work. This is made up of well-wooded land, and from the investigations in conditions of growth, the department is securing valuable data.

Following the tour of the nurseries, the guests assembled in the dining room of the pavillion where Hon. Mr. Allard delivered an address of welcome. Mr. Piche followed with a paper on reforestation problems, which the Forestry Journal will shortly publish. Mr. Ellwood Wilson, forester of the Laurentide Company, and Mr. F. W. Reed, of the United States Forest Service, lead the discussion. This centered upon the inadequacy of present timber cutting regulations which, as frequently pointed out by the Canadian Forestry Association, must bear a serious share of responsibility for deteriorating tendencies in eastern Canadian forests. It was pointed out at the meeting that the theory underlying the regulations was incorrectly based

and did not accomplish what was intended. Trees left after the first cutting did not commonly provide a second crop, but were subject to windfall and rot with usually very little increment in growth. As Mr. Wilson remarked: "We cannot afford after fifty years to establish camps to cut only 2½ cords per acre". By cutting clean under proper regulation, two major results would be accomplished: good natural reforestation would ensue, and slash disposal could be carried on under ideal conditions. The riddance of debris was a pre-requisite of thorough fire prevention. Mr. W. Gerard Power strongly supported the claims for clean cutting and mentioned the fact that he had been conducting some experiments on reproduction on burned-over areas.

Mr. Reed brought forward some interesting experience from United States practice and approved of clean cutting in spruce forests.

At Grand Mere, the delegates were taken to the Laurentide company's nurseries and the

reforested area at Proulx. This will be made the subject of a special article in an early issue of the Forestry Journal. The Laurentide company planted 912,000 seedlings in 1919, and expect to put out more than a million annually from their own seed beds. The Laurentide company and Mr. Wilson were thanked heartily for the courtesies afforded during the Grand Mere visit. A similar expression was conveyed to Hon. Mr. Allard and Mr. Piche.

A very interesting incident of the visit was the demonstration of the hydro-aeroplanes recently obtained from the Dominion Government for forest patrol experiments by the St. Maurice Forest Protective Association. Mr. Stuart Graham, the aviator, took one of the machines into the air from the surface of Lac Tortue and flew over the heads of the party at an elevation of a few hundred feet. The management of the machine was perfectly ordered and greatly impressed the onlookers.

## ONTARIO'S FOREST POSSESSIONS

*By James White, Assistant to Chairman, Commission of Conservation.*

Regarding the survey of the forest resources of Ontario, the Commission of Conservation has been assured of the fullest co-operation of the Ontario Government in this undertaking and proposes to start at once on the completion of the data.

It took practically four years to complete the report on the "Forests of British Columbia" which has lately been issued and it is expected to take nearly as long to prepare a similar report for Ontario. Much will depend on the various departments of the government and from the timber owners. It is, of course, impossible for the Commission to attempt to cruise the whole province and since such a large proportion of the merchantable timber is in private holdings, for which the owners have detailed cruises, it would be extremely wasteful both of time and money, to duplicate this work. The Commission is therefore depending on the lumbermen, as it did in British Columbia, to supply the information they possess. It may be pointed out that, in British Columbia, detailed cruises were secured on 70 per cent of the alienated lands and in only two or three unimportant instances was the information withheld when available.

### Ontario's Co-Operation.

Through the courtesy of the Minister of Lands, Forests and Mines of Ontario, the Commission will have access to all the cruises and reports in his department. Other sources of information will be cruisers, rangers, surveyors, explorers, etc., who have knowledge of local conditions, and, in addition, a considerable amount of field work will be conducted to check and connect up the data received from other sources.

The individual reports will be treated as confidential and used only as a basis for arriving at totals for large drainage areas embracing many holdings. It is hoped that sufficient data will be collected to permit of a general classification of the land as to whether it is wasteland or is suitable for agriculture or for forestry. Maps will be prepared, showing in a broad way the various forest types as regards composition and yield.

The report on the "Forests of British Columbia" has been received with the marked appreciation of the timber owners, lumbermen and others interested in the development of the forest resources of that province and it is felt that

information of a similar nature should be available for the rest of the Dominion.

### Saskatchewan Report Soon.

The Commission of Conservation has completed a survey of the forest resources of Saskatchewan but, owing to the illness of the forester who conducted the investigation, the completion of the report has been much delayed. It is hoped, however, that it will be in the hands of the printer at an early date. In 1909-10, a similar survey of the forests of Nova Scotia was made by the government of the province. When completed, the report was published by the Commission of Conservation.

Much data respecting the forests of Alberta and Manitoba have been obtained by the Forestry Branch, Department of the Interior, and when supplemented by some further investigations, will be available for publication. The forests of New Brunswick are now being surveyed by the government of that province. Ontario and Quebec, therefore, are the only provinces in which a very large amount of investigatory work is required and, if the survey of Quebec's forests is undertaken by the Quebec Government, we may look forward with confidence to the completion, at a comparatively early date, of the survey of the forest resources of Canada. Then and then only, will we be able to formulate with confidence specific measures for the areas of Canada that contain forests and for the areas that are suitable only for the growth of forests. Unfortunately, when com-

pleted, this survey will demonstrate that the optimistic statements respecting our "illimitable" and "inexhaustible" forest resources have no foundation in fact.

### Canada Needs Production.

Forests are primarily valuable for the production of wood. At the present time, Canada needs increased production as never before, but the fact must not be overlooked that we shall require sustained production for several generations in order to meet the obligations which the war has imposed on us. That our forests may be used to the best advantage, it is necessary that we first know what stock we have on hand; second, what future crops can be looked for; and third, what means can best be adapted to sustain and increase production. This knowledge is perhaps more valuable to those engaged in the forest industries than to the governments since a knowledge of the available supplies will enable them to so plan their operations that their plants may be kept running. The increasing shortage of supplies is becoming a serious matter, especially for the pulp industry and the problem of reproduction either naturally or by planting, has become a live issue. The Commission of Conservation is conducting an extensive investigation of this subject and with a knowledge of the virgin supplies, basic information will be available as to the practical possibility or advisability of adopting means of maintaining the productivity of their timberlands.

---

## WOMEN MAKE GOOD AS LUMBERJACKS

(*Mr. Geo. Leven, at Meeting of Royal Scottish Arboricultural Society*)

---

"At the present moment I could specify one estate in the south-east of Scotland where women have undertaken very important work during this past season. They have not only been useful in planting operations and in felling and cleaning pit-wood, but they have tackled trees of a cubic capacity of 230 feet and felled them to the satisfaction of merchants and others. That is a very big undertaking and there are many people who would scarcely believe it, but it is absolutely the case, and I believe if we could devote more attention than we have done

in the past to better tools, better equipment, and perhaps a little better accommodation than some of them have had, that we would be able to make use of a very great number of women. I do not think it is altogether fair that we should treat them as beasts of burden. We should make some provision for training them, because I am absolutely convinced they can do a great amount of the work that falls to men in forestry. The women I have referred to have been able to do almost all the work with the exception of "laying in" these very large trees."

## CAN TIMBER LIMITS BE MAPPED BY AIRPLANE?

By *Rolph Thelen.*

The development of aerial photography as a highly important and indispensable phase of modern warfare has been one of the many wonders of the great war. Photographic reconnaissance was practically unthought of during the early stages of the conflict, and may be said to have been an outcome of trench warfare. At the time the United States entered the war this art had become of tremendous importance, and in the final stages a complete detailed photographic map of each sector had to be made daily. General Squier states that the British army made 17,000 photographs before the operations at St. Quentin in order that a relief map of the whole sector might be prepared before undertaking the drive.

Military maps of this character are commonly called mosaics, and are made as follows: An airplane (other forms of aircraft could be used under certain conditions) equipped with a magazine camera flies over the area to be mapped, maintaining as uniform an altitude as possible, and exposures are taken at the proper intervals to insure a sufficient over-lapping of the resulting negatives. If the area is too wide to be mapped in one flight, a number of parallel flights must be made, and the negatives of each succeeding flight must overlap those of the previous flight. After the negatives have been developed, prints are all made to the same scale; this is done by making them in an enlarging camera instead of by contact. Distortion, caused by obliquity of the plate at the instant of exposure, can also be corrected in the enlarging camera if proper base points are available. The cameras are usually rigidly attached to the planes, and since it is impossible to fly continuously on an absolutely even keel, a certain amount of distortion is bound to occur. After the prints are made, they are matched up, trimmed and assembled into the finished mosaic. It is obvious that in the case of flat terrain it is possible by this means to product an accurate scale map. However, in the case of mountainous country, this is not possible, since the scale will vary unevenly throughout the negative with variations in elevation. Thus a peak will be abnormally large in scale compared with a valley appearing in the same photograph, since it will be nearer the camera in elevation at the instant of exposure. The summit will be large scale, the valley small scale, and the slopes on

various intervening scales. In spite of this undesirable feature this type of map answers military requirements admirably, especially when accurate scale maps of the region are available, as was the case in France, and the main need for the photographic maps is to show the activities of the enemy. Points on the photographs can be tied in with the corresponding points on the scale maps, and the desired amount of detail filled in with almost any degree of accuracy. The speed with which aerial mosaics can be made is remarkable. The Division of Military Aeronautics recently made a mosaic of the City of Washington and surrounding country in a total flying time of only 2¼ hours. The area covered was 27 square miles.

The possibility of producing accurate topographic maps from photographs has been appreciated for many years, and the camera has been used for topographic surveys to a limited extent in India, France, and Italy, and almost exclusively in the Dominion of Canada. Cameras used for this purpose are known as phototheodolites, and are equipped with suitable cross-hairs leveling devices, horizontal scale, and magnetic compass, as well as with a small telescope for the reading of vertical angles.

### ARSENIC TO KILL USELESS TREES.

"Of late years, the action of arsenic has been introduced with marked success in hastening the killing by the ring-barking process, and trees that ordinarily would take months to kill by the old method, are now killed in a few weeks, and frequently in a few days, by the application of arsenic."—Australian Forestry Journal.

St. Johns, Nfld., July 4.—Reports say that a big forest fire is raging on the Exploits River, and that dwellings near Exploits were in danger. Minister of Mines and Agriculture Walsh received the following message from Badger last evening: "Fire has encircled Badger, but so far only one house has been destroyed. Another has been badly damaged. The fire has crossed to the south side of the Exploits River, and the place is still in danger. Forest fires are now raging within a radius of ten to twelve miles north-east and spreading to south side of river."

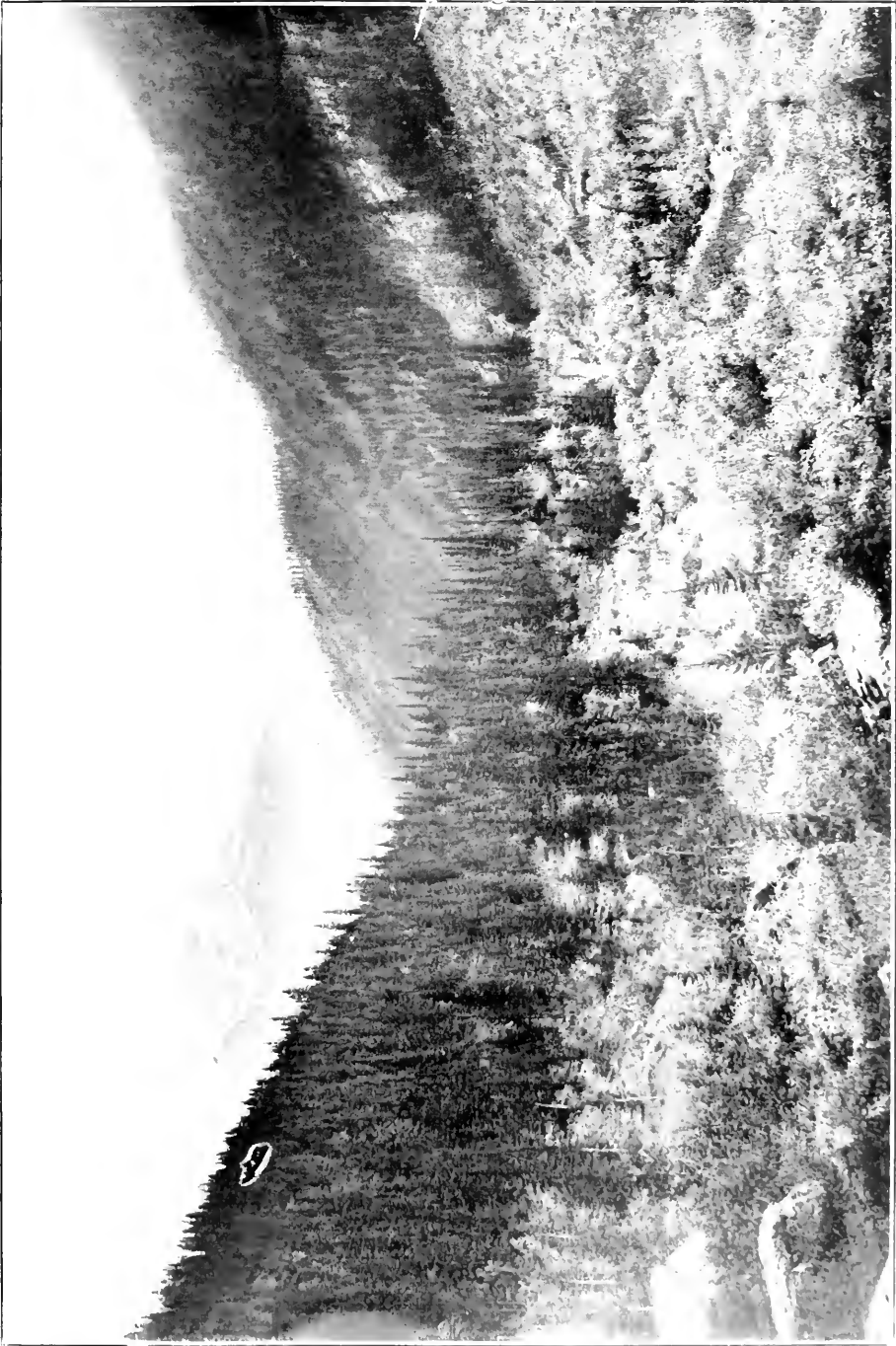

Entrance to Yoho and Pass, Jasper Park, B.C.

## MAKING FORESTRY PAY ITS WAY



How a Stave Mill, Erected to Consume  
Useless Hardwoods Turned in 42  
per cent.



The necessity of compromise between the ideal forest of the technical expert and the forest that can be developed within the restricting lines of profit-making, always provides a halo of interest for any experiment in technical woodland management. At a recent meeting of the Pennsylvania Forestry Association, attended by the Editor of the Canadian Forestry Journal, Mr. Alfred E. Rupp, Forester of the Buchanan Forest of Pennsylvania, recounted the story of an experiment in the manufacture of staves which netted 42 per cent profit. The operation was not intended to help out the stave supply but primarily to remove from a tract all trees without future value so that young valuable species might develop and form the predominating stand; secondly, to market the products at a fair profit; thirdly, to train sawyers and operators for future stave mill operations.

This has a special point of contact with one of the gravest problems of operating the great spruce forests of Eastern Canada on a basis of sustained yield. In Central Quebec, for example, the removal of white spruce brings along a second crop of hardwoods and balsam fir in which a new growth of spruce is an uncertain factor. To remove the hardwoods, obviously, will encourage the spruce, but how to make a profitable logging proposition out of what undoubtedly is good forestry practice brings up one of the knottiest questions of the hour.

### A Better Forest.

It is not suggested by the Canadian Forestry Journal that a profit of 42 per cent can be promised on such an enterprise as Mr. Rupp's under Canadian conditions for it must be remembered that the bulk of the machinery was bought at scrap iron prices and some of the labor performed by state employees was not charged up to the final reckoning. The transportation situation was strikingly better than would be encountered in Northern Ontario.

The chief problem before the eyes of Forester Rupp was to improve reforestation conditions on the areas in his charge. He found the land lumbered by a growth of fire-scarred,

blighted, crooked and timberless trees, making reproduction of valuable species exceedingly difficult. The entire area had been lumbered between 1900 and 1910, and all timber trees were cut at that time. To cut for cordwood was out of the question, owing to costs of transportation, etc. Mr. Rupp therefore set about to remove the useless trees and give a growing chance to the seedlings of more valuable species. Every care was taken, and additional expense incurred to save the young growth from damage.

On 33 acres of the tract planting had been done from 1911 to 1915 as follows: 30,000 white pine, 27,000 Norway spruce, 4,000 white oak and numerous other species. The young trees demanded more light and the canopy had to be thinned.

### Liberal Profits.

Said Mr. Rupp: "We did not begin sawing staves to see how much money could be made. We are working for future benefits. If this operation assures this, we need make expenses only to justify the operation. We have made more than expenses as the following statement shows: We have sawed 501,944 staves, which were sold f.o.b. our shipping point for \$5,019.44. The cost of manufacture to date is \$3,528.44. The profit therefore is \$1,491.00, with a large amount of unsold material on hand. The operating expenses are proportioned as follows: Logging 23 per cent, sawing 62 per cent, marketing 15 per cent."

"The Department of Forestry paid \$2.00 an acre for this land. At an expense of \$13.25 per acre, 33.8 acres of the area were planted in trees. The shelter trees in the plantations have all been removed, and about 25 acres additional have been cleared of all large growth. The chestnut has been removed from 80 acres by selective cutting. The removal of this timber and its manufacture into staves has paid the Department more than \$10.00 an acre. This is \$8.00 more than was paid for the land. We expect the cleared area will reforest itself in tulip poplar, and the selective cutting area in hickory and chestnut oak. Great care, at extra



expense, was exercised in the logging operations to save the young growth. We have reason to believe that the treated areas will become as valuable as the planted areas.

"The total amount of the department investment is \$1,730.00, which includes team, wagon, engine, mill machinery, and buildings. The profit of the operation to the present time is \$239.00 less than the cost of the equipment; but the drying yard contains 70,000 staves unsold, and 150,000 staves are still to be manufactured from this area. The large chestnut and poplar logs have not been used for staves, but are reserved for lumber. These logs, with oak, maple, ash, and cherry, will cut 75,000 board feet of lumber. We have 50 cords of locust for insulator pins and 60 cords of wood for fuel to be removed from the area. The brush has been piled and will be burned when weather conditions permit.

#### Making Mill Managers.

"Permit me again to mention the purposes we had in mind before the operation was started:

1st. The removal of all trees necessary to the well-being of the future stand. This has been done with one exception. No trees harboring squirrels have been cut. No matter how

unsightly they were, no exception was made to this rule.

2nd. Profit. A profit of \$2.97 a thousand on the staves, \$5.34 stumpage in terms of cordwood, and \$10.68 a thousand in terms of board feet, was made on the operation. More than \$10.00 an acre has already been cleared on land purchased by the department for \$2.00 an acre, with other profits to follow and to be accounted for.

3rd. Training for future service. That "experience is the best teacher" is exemplified in this operation. Our blue print was a memory print of a mill worked on 20 years ago. Many of the mill parts were missing and it was necessary to replace them. The hard work done by the rangers assured the success of the enterprise. Thirty-one per cent of all the labor expended on the operation was furnished by the rangers and the forester. The salaried men of the department are skilled in operating all the machines and can superintend their erection and operation. We can now offer to the department of forestry three employees who can superintend stave mill operations. They are worth more to the department than a 42 per cent profit on the manufacture of keg staves."

## BUILDING A NATION ON A TREE FARM

By Robson Black.

(Continued from June issue.)



Canada's Forest Possessions Have Been the Backbone of Continuous Prosperity.—  
What the Future Promises.



#### Our Debt to the Lumberman.

Though we may have paid the price in a diminution of the rich supplies of standing timber, the unhampered exploitation of the forest resources has undoubtedly had many and mighty compensations. Lumbering, our most widely distributed industry, has opened up countless productive agricultural and grazing areas, and has supplied winter employment for tens of thousands of farmers through their first attempt at field crops. Lumbering has always been the country's greatest employer; it is a greater wage distributor, and, with pulp and paper making, holds more capital than any other Canadian industry. Faith in Canadian potentialities has in this matter been correctly founded. The development of her natural resources is Canada's obvious path to prosperity. True, we have diverted much time and capital to not a few industrial exotics, but that has a fashion of correcting itself periodically. The manifest starting point of a young nation such as Canada is to

seek to specialize in the least crowded field, to carry to market those wares that are subject to minimum competition. For instance, eighteen years ago, Canada's paper sales to the United States were just \$122. The pulp and paper exports in 1918 exceeded \$60,000,000, and the main reason for this phenomenal growth is that Eastern United States forests have "pinched out", or water powers have failed or risen to excessive cost, whereas in Canada, there remained that happy trinity for paper industries: wood, water powers, and transportation.

The industrial position of the pulp and newsprint paper mills in particular is not surpassed by any achievement of the United States. The point of apprehension, therefore, is not that the Canadian manufacturers of wood products need fear the ordinary tides of competition but that the supplies of accessible forest materials may prove unequal to the demand. This is no longer a mere sour speculation. Lumber companies have been forced in many instances to face total depletion of timber supplies, particularly white pine, while even some more recently developed pulp companies are not a little handicapped by a failing source of accessible spruce wood. Corroboration is found in the constantly ascending price of timber limits, particularly in Eastern Canada, the advancing of Government dues as fast as old agreements expire, the reduction of "estimated" timber stands on much of the public and private lands as accurate cruises are applied. This not only presages a dilemma for many industries which cannot survive a greatly increased cost for long hauls on their wood, but it materially restricts development of new industries and curtails the country's advantages in foreign export. The latter is of exceeding importance, for our exports of forest products have overtopped every other manufacture except the temporary output of munitions. To maintain and improve the nation's export business is the most pressing concern of our financial statesmanship. Is it too much to ask, therefore, that the examination of the various factors in export trade of pulp and paper and lumber should show some penetration, and that our national government taxing its brains over creating post-bellum exports might with profit give some attention to the living forest that lays the largest of our export eggs?

### **Canada's Great Tree Wealth.**

The vital importance of forests to Canada cannot well be overstated. This seems so obvious that one would expect to find forest management a highly organized and advanced function of all governments these many years. Two-thirds of the Dominion is incapable of producing other than timber crops. Of the 163 million acres of Alberta, for example, not more than thirty per cent are capable of cereal production, and in 1915 only 6,000,000 acres were actually tilled. Quebec had a hundred years start in agriculture, and yet but nine out of 200 millions of her acres are under farm; nor can that ratio ever be seriously reduced by agricultural expansion. Nearly seventy per cent of New Brunswick is fitted by natural conditions for timber-growing, and for that alone. But forests, however vital to national existence, are backward political advertisers, and public policies in Canada have in a marked degree been formulated not primarily from scientific considerations but from respect for political consequences. Neglect of the forest breeds no consequences of such a sort; dead timber lands tell no tales.

### **Public Control of Forests.**

Notwithstanding all the unmatched lethargy in the rudiments of public forestry, it is fortunate that no Canadian Government made the supreme blunder chargeable to the people of the United States of parting with the control by outright alienation of four-fifths of the republic's timber lands. Not more than five or ten per cent of the ground title in the whole forested area of Canada has passed from the Crown. It is true that more or less self-perpetuating leases of the most accessible timber growing on the Crown lands have been granted to hundreds of private corporations, but the state still retains the whip hand of a leasing system. This most fortunate restriction, from which no government since the days of the French seigneurs has deviated except for railway grants, reserves to the Canadian people ample power to impose whatever conservation requirements immediate or future public needs may dictate. The United States lacks this weapon, except upon about one-quarter of the national forest domain, although on that

quarter of the Forest Service has applied the nucleus of silviculture management. As to the power of a Canadian Government to revoke a timber cutting license, this is not exercised except for flagrant breach of regulations; and over much of the licensed area official supervision of operators is yet so slight as to make the operator's conscience the main crutch for statutory observances.

Although in all civilized lands forest materials enter into the processes of production to an amazing extent some nations, as the United Kingdom, manage to maintain commerce even with the handicap of importing seven-eighths of all wood materials used. Canada, however, maintains foreign trade in normal times on the strength of primary products, and the products of the forests occupy a place in the export trade of Canada second only to those of agriculture. In the fifty-one years since Confederation, the values of various classes of exports have been as follows: Agricultural products, \$2,010,298,011; animal products, \$1,743,974,236; the forest, \$1,418,568,514; the mine, \$849,845,443; the fisheries, \$485,298,526; manufacturers, \$898,623,720; miscellaneous, \$20,857,806; total exports, \$7,427,466,256. Our agriculturists, producing cereals and live-stock, are prolific wood consumers, employing about six times as much building wood per capita as the European farmer. Our fishermen rely upon cheap wood supplies for their fishing nets, their boxes, barrels, and buildings. The coal mines of Nova Scotia and Alberta stand helpless without pit props. To meet the thousands of producers in the irrigated sections of Alberta is to recognize one of the foremost services performed by the forests of the eastern slopes of the Rockies, that of maintenance of stream flow. Not only, then, is the forest in Canada to be identified as the supplier of the lumbering and paper-making industries, but in its contributory relations to all other natural resources and forms of development it is an absolutely essential balance wheel.

The total area of forested lands in the Dominion is approximately four hundred million acres. As to timber contents, British Columbia tops all the provinces with about three hundred billion board feet, one-half the amount of timber growing in the whole country. Quebec, Ontario, New Brunswick, Alberta, Nova Scotia, Saskatchewan and Manitoba rank in the order given. Canadian forest conditions to-day, however, represent a strong modification of those existing even a century ago. At the time of the Napoleonic wars, Canadian soil under plow crops formed a trifling contrast to the vast regions of untouched timber. Always we have had the barrens of Ungava and the far-reaching profitless tracts sweeping north-westerly to the mouth of the Mackenzie River, where only petty vegetation thrives. The treeless prairie, then as now, almost devoid of trees, covers a triangular shaped wedge extending from eastern Manitoba to the Rocky Mountains, the apex penetrating 260 miles north of the international boundary, on the North Saskatchewan River.

(To be continued in August issue.)

## \$14,000,000 FOR FOREST ROADS

---

A safer insurance against devastating forest fires, a realization of the recreational advantages in endless miles of wooded scenery, and a fuller comprehension of commercial benefits accruing through the linking up of national forests with bordering highways are the impelling motives in the programme for the coming year for building 1,643.3 miles of forest roads under the supervision of the United States Forest Service.

The first federal effort towards road building

in the national forests came in 1912 when the so-called 10 per cent fund was formed. It provided that 10 per cent of all receipts from the national forest funds be used in the construction and maintenance of forest roads. It was not necessary that the state or states in which the roads to be constructed should co-operate financially in the venture. The only stipulation was that the money should be spent in the same district as that from which it was derived.

## PUBLIC MUST PILOT FORESTRY POLICIES

---

Col. Henry S. Graves, head of the United States Forest Service, speaking at Boston on "The Need of Private Forestry," said:

"If the war emergency had come fifteen years later we would have had great embarrassment in obtaining the lumber needed for general construction. Four-fifths of the timber of the United States is in private hands and 97 per cent of our wood comes from that source. According to leaders of the southern pine industry the original supplies of southern pine in the south will be exhausted in ten years, and in five years not less than 3,000 mills will go out of existence. Pacific coast timber is already enter-

ing the eastern markets, and this means that the price of home grown timber has risen to a point making it possible to ship lumber 3,000 miles in competition with it."

Col. Graves said that in order to obtain good timber the state must direct the work of fire protection and enforce drastic fire laws. He believed that the public should provide a sane system of taxation and should co-operate in such economic problems as over-production of timber, problems of labor, technical questions relating to forestry and a variety of other industrial and technical matters that are encountered in carrying out in practice a systematic programme of forestry.

---

## FORESTRY PROPAGANDA IN CANADA

---

At the invitation of the Pennsylvania Forestry Association Mr. Robson Black, Secretary of the Canadian Forestry Association, addressed a gathering of Americans on Canadian forestry problems and the methods of operation of the Canadian association. Great interest was displayed in the rapid progress of forest fire preventive work throughout the Dominion, and particularly in the success of educational work.

Mr. Black explained to his audience that unlike ordinary propaganda, the spokesman for forestry could not promise quick, tangible profit. People accustomed to political and commercial appeals, based upon immediate likelihood of gain were slow to take up cudgels for a cause that spoke of a social and national profit fifty or a hundred years hence. Yet, in a country where 90 per cent of the forest lands were owned and governed by the people and where timber operators were annual tenants, any advancement of state control of forest policies depended absolutely upon arousing the masses of citizens to their public privileges and responsibilities. The Canadian problem was, therefore, not quite the same as that of the average American state, where only a small fraction of the forest wealth had not been alienated and placed beyond public control.

The methods employed by the Canadian Forestry Association were explained in detail by the speaker, who claimed that one of the basic

reasons for success in forestry propaganda is to keep the organization free from any governmental or commercial affiliation. This allowed perfect liberty to carry on constructive agitation, which, at times, must run counter to governmental tradition, and perhaps displease certain commercial interests. Mr. Black described reforms in province after province of Canada due largely to educational campaigns.

The Forestry Association, he said, devoted the greater part of its attention to improvement of public policies and administration. At the same time, it initiated and carried out scores of educational enterprises aimed at securing the good-will and co-operation of the individuals responsible for setting forest fires. Scores of thousands of school children and teachers, settlers, railroad men, and other classes were reached year by year with attractive literature, and by motion pictures and special public speakers. This was a branch of work, said Mr. Black, which plays directly into the hands of practical rangers and their scheme of patrol, for it went far deeper than mere fear of the law and gained voluntarily what under no circumstances can be compelled by magistrates and fines.

---

Leaving out of consideration the overcutting caused by the war, the forests of Denmark yielded a net return varying from 3.9 per cent to 13.9 per cent, and averaging 7.7 per cent.

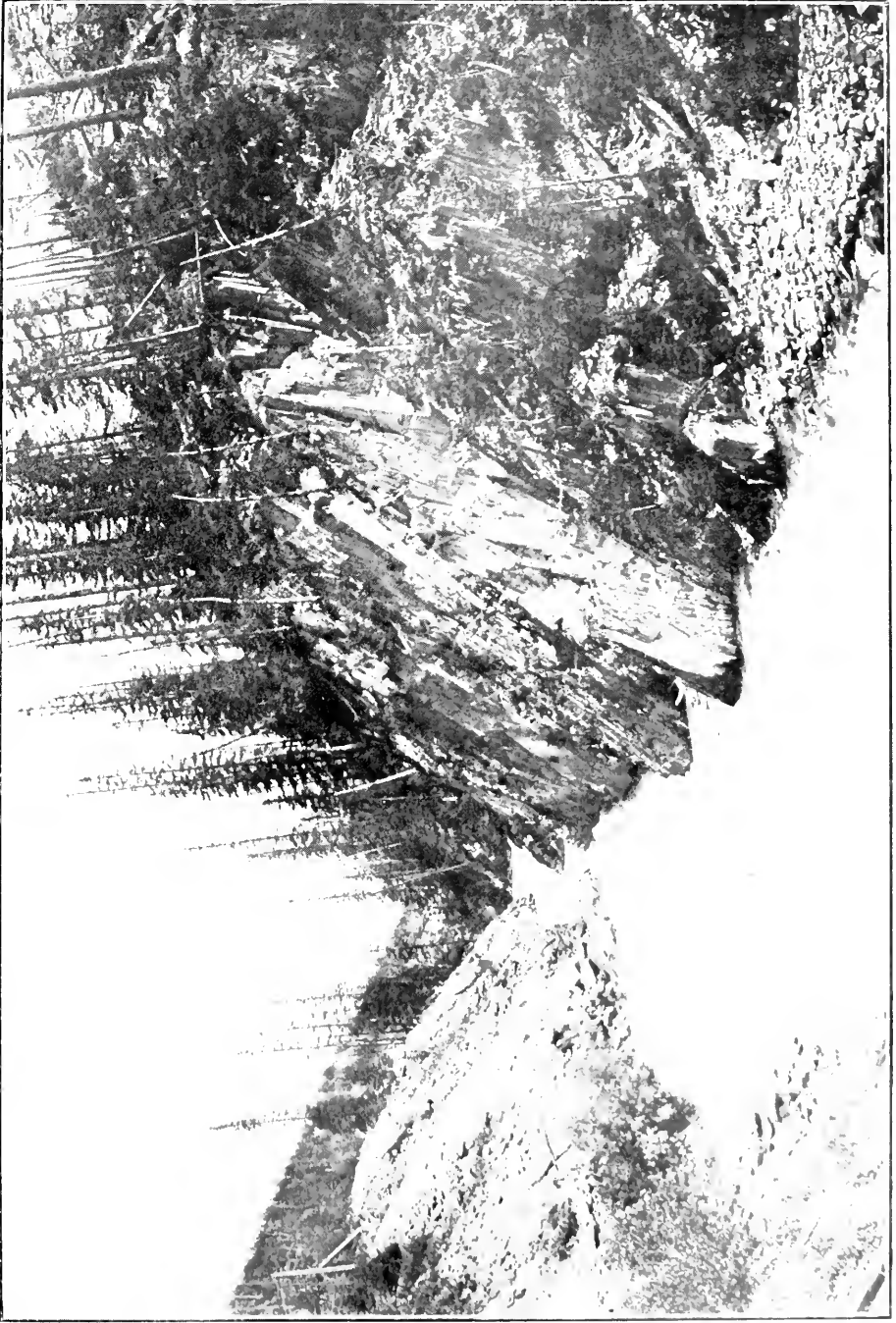

Looking along Kicking Horse Canyon, B.C.

# ONTARIO'S FOREST FIRES DURING JULY

The Ontario Forest Service, which was placed on a modern basis in 1917, has been passing through more fire trouble in the northern districts than was encountered in the two previous years. It is impossible to give a summary of the fire losses as this issue of the Journal goes to press, as a number of the fires outside the Claybelt region have been reported only in a general way. After the bad fire period is over, detailed estimates are sent to headquarters at Toronto. As far as present information goes, the bulk of the Ontario fires have occurred on cut-over lands where slash has accumulated.

The fires in the Claybelt country while covering comparatively large areas have burned off what is to be agricultural land and to a large extent over areas that have been cleaned out of pulpwood and tie material. No lives have been lost, but by July 10th between forty and fifty settlers had been burned out.

It is an unfortunate element in Ontario's forest protection situation that the settlers of the north country are preponderatingly in favor of indiscriminate burning, and this despite the terrible experiences of 1916 and 1911. The Ontario law requires every settler to first obtain a permit from a ranger before starting to clear his land by fire, and imposes such regulations as the piling of brush, obedience to the ranger's orders regarding time of burning, etc. Without vigorous local support of such requirements, however, enforcement is very difficult. A large proportion of the fires sweeping parts of Northern Ontario during the first weeks of July were directly and solely attributable to the settlers' defiance of Ontario law. Several prosecutions are now under way, and a few stiff fines would help correct conditions. A change in the Ontario law to permit imprisonment of settlers is not improbable.

## FOREST FIRES IN NEW BRUNSWICK

By G. H. Prince, Provincial Forester.

Fredericton, N.B., July 11, 1919.

The fire season in New Brunswick may be said to be more severe than 1918 owing to extended period of dry, hot weather. The organization of the Forest Service is proceeding favorably, but is not complete, owing to a considerable number of ranger appointments not being confirmed after the six months' probationary period. An examination will be held on July 30th when it is expected that all vacancies will be filled by returned soldiers.

A summary of the fires compiled to date is submitted, but does not include, of course, all fires that have occurred to date:

|                                     |     |
|-------------------------------------|-----|
| Total number of fires reported..... | 220 |
| General causes .....                | 76  |
| Railway causes .....                | 144 |

Thirty-seven of railway fires occurred on right of way, and 107 were reported as tie fires.

The total estimated damage is in the vicinity of \$120,000.

|                                       |         |
|---------------------------------------|---------|
|                                       | Total   |
| April fires, 2 railway, 2 others..... | 4 fires |

|   |           |
|---|-----------|
| May fires, 19 railway, 39 others.....   | 58 fires  |
| June fires, 125 railway, 33 others..... | 158 fires |
|   | 220 fires |

### Causes.

|  |          |
|--|----------|
| (a) Settlers neglecting slash fires or carelessness, which resulted in \$50,000 damage ..... | 30 fires |
| (b) Fishermen, campers, picnic parties .....   | 23 "     |
| (c) Railways .....   | 144 "    |
| (d) Accidental .....   | 3 "      |
| (e) Careless use of fire, industrial....   | 12 "     |
| (f) Incendiary .....   | 5 "      |
| (g) Unknown .....  | 3 "      |

220 "

Twenty-four prosecutions for non-observance of the fire law are in course of action, nearly all of which are in connection with the Kedgwick fire which destroyed so much property. These cases will be heard in Kedgwick on July 16th before Judge Matheson. Complete figures regarding this fire have not been tabulated, but it appears that a large number of settlers during

very hot, dry weather of June set fire to their slashings without permits, and these fires got beyond control with disastrous results.

The area of ground covered by all the fires in the province to date is approximately 10,000 acres.

The fire protection staff at present consists of:

|                                 |     |
|---------------------------------|-----|
| Rangers and inspectors -----    | 40  |
| Temporary fire wardens -----    | 32  |
| Co-operative fire wardens ----- | 60  |
| Voluntary fire wardens -----    | 154 |
| Road commissioners -----        | 490 |

Total ----- 776

Splendid results have been secured by the co-operation of the Public Works Department of the Provincial Government, whereby the

Minister of Public Works has authorized 490 road commissioners to act as fire wardens in case of fire in their vicinity. Also great assistance has been rendered by the lumbermen of New Brunswick, who have given the services of 60 of their woods superintendents and foremen as co-operative fire wardens.

1,500 school teachers have been circularized regarding fire protection; 14,000 camp fire books have been distributed.

15,000 fire posters have been placed in the field.

One look-out has been connected with telephone and watchman employed.

Preparations are being made for three others, and considerable amount of woods telephone lines.

## NOVA SCOTIA ESCAPES HEAVY LOSS

*By T. A. Harrison, Deputy Commissioner of Crown Lands.*

Halifax, July 9, 1919.

The total number of fires reported to date, twenty-three, with an estimated damage of \$1,000.00. Of the twenty-three fires reported, ten were caused by railways, six by fishermen, two by farmers, and five unknown.

Judging from past experience, and particularly from the past four years, during which time a record has been kept, it is not probable that the damage will be much greater, as the records show that practically all the fires occurred in the month of May and the first two weeks of June.

## MAKING SLASH BURNING A SAFE JOB

*By Henry Sorgius, Manager, St. Maurice Forest Protective Association.*

*From an illustrated bulletin, published and distributed free by the Canadian Forestry Association, 206 Booth Building, Ottawa.*

The settler must always bear in mind that the fire ranger is his friend, and is always willing to help him out by giving good advice in the burning of his slash to clear his land. Having burnt many slashes he is more or less of an expert in this work and can help the settler materially by having the slash piled and fired with the maximum results and minimum danger and trouble. The fire ranger is just as anxious as the settler that his slash should be burnt without causing any damage or trouble.

### Proper Piling Comes First.

The first duty of a settler who wants to burn his slash is to see if it is properly piled and at least 50 feet from any standing timber or building and it would be advisable when possible to have it at 100 feet in which case it would reduce the danger. Once this is done he should then obtain a written permit from a duly appointed ranger who will visit his slash and gladly issue a permit if he finds that the slash

is piled to avoid any possible danger to the standing timber or buildings and if weather conditions are favorable.

#### Never at Midday!

A settler should never set fire to his slash at midday or when there is a heavy wind blowing. He should always set fire in the evening. Then if anything should go wrong he will have more facilities in extinguishing it. He should never set fire to too many piles at a time; he should burn one or two at a time, as otherwise he would never be able to control them. He should have the necessary help on hand according to the size of slash that he has to burn and always have pails and shovels with him so he can extinguish fire if it should happen to spread. If the fire is still burning in the morning it should be extinguished, except during wet periods, as the heavy winds during the day may cause it to spread. A good time to set fire to a slash is just before it is going to rain, then he will be assured that his fire will never run and cause any damage.

#### Have Help at Hand!

The very best time to burn slash is in the early spring when there is still snow in the woods.

There is no reason why a settler burning a slash should cause any damage if he takes the necessary precautions. He should always remember the following:

1. To pile his slash in heaps.
2. To have the heaps at least 50 feet from any standing timber or building.
3. To obtain a written burning permit from the fire ranger.
4. To never set fire at midday but in the evening.
5. To never set fire when a heavy wind is blowing.
6. To have the necessary help at hand to extinguish fire if it should spread.
7. To have pails and shovels with him.
8. To never leave a fire before it is completely out.
9. To try to burn during a wet period.
10. To always remember that the fire ranger is his friend.

It is easier to burn slash by taking the necessary precautions beforehand than to try to extinguish a large forest fire.

## UP AND DOING! A CALL TO PLANT TREES

By "Ahmik", Agricultural Editor of "The Globe", Toronto.

In the plans being formulated for reconstruction forestry should have a leading place. More particularly does this hold true of Ontario and the Western Provinces. The southern part of the prairies are practically a treeless waste. A large portion of the best part of Ontario is being rapidly reduced to the same condition.

In Huron, which in the memory of men still living was known as "The Queen's Bush", with 800,000 acres of assessed land, only 48,000 are in the bush; in Grey, despite the fact that much of the land is fit only for the growing of timber, there are but 113,000 acres of bush out of more than a million acres assessed.

In unbroken counties, nearer the front, the showing is much worse. Brant, with 216,000 acres assessed, has only a little over 9,000 in bush, and Peel, with 297,000 acres assessed, has a trifle over 8,000 in woodland. There are at least twenty counties which have 80 per cent or more of their area cleared, and even at this "waste", "marsh" and "slash" are included in what is classed as the "uncleared" percentage.

If the northern districts, such as Parry Sound and Nipissing, are left out it will be found that Ontario, which was all bush a little over a century ago, has a smaller percentage of forest to-day than has Germany, which country has been settled since before the dawn of civilization.

#### A Chilling Prospect.

In western Ontario, that is, in the portion of Western Ontario south of the Great Lakes, and in eastern Ontario, excluding Renfrew and the unorganized districts, there is not sufficient timber left to provide proper climatic conditions and ensure the conservation of the water supply. If what we speak of as older Ontario were cut off from all outside sources of fuel supply, the population would freeze to death in a few years—that is, unless a wholesale exodus took place.

And the time may not be far distant when we shall be forced to depend mainly on ourselves for the fuel needed. The coal famine of last year, due to the way, may, before long, become



a chronic condition owing to the depletion of American supplies on which we have heretofore depended. Once a coal mine is worked out it is done for. Coal does not grow like trees. True, there is wood in the north country, but wood is such a bulky article that the distance over which it can be transported, save at ruinous cost, is limited. Furthermore, the hardwood area does not extend so very far north, and softwood is a most unsatisfactory material for the supply of heat in winter.

#### **Should be Self-Supporting in Fuel.**

Old Ontario should be self-supporting in the matter of fuel, and could be made so in a comparatively few years if land practically valueless for agricultural purposes were devoted to its proper use—the growing of trees. There is not a county in old Ontario in which there is not some land that is useful for no other purpose. Even in some of what we call “good counties” there are considerable areas that are worse than useless with the timber off them—that threaten to become sand wastes, and as such a menace to good agricultural land in the neighborhood. This is true of Huron, of Simcoe, of Durham, and of other counties that might be named.

#### **Other Advantages to be Gained.**

With these waste areas reforested the force of the wind would be moderated, water would be more abundant in streams and springs, rainfall would be more dependable, good land would be more productive. Incidentally, by a proper system of conservation applied to the timber growth, an abundant supply of excellent fuel would be assured for all time at moderate cost.

Nor would it be necessary to wait so very long before returns would begin to come in from planting. Beech and hard maple are slow growers, but Manitoba maples grow quickly into useful wood. Willows, planted in marshy places make rapid growth, and when a willow tree is cut down fresh growth will start from the stump. And willow makes good summer fuel at least. Even beech and maple do not take so very long to make their growth. Men in the prime of life can point to maples nearly two feet in diameter that they planted as saplings.

#### **Community Effort Called For.**

How is the work of reforesting waste areas in this province to be carried out? It is useless to depend on individual effort for what should be done. Not many men will plant where they cannot expect to reap. Besides, a man may set out a plantation to-day that his successor of tomorrow may look upon as an encumbrance, or at least treat with neglect. Community effort,

either through the province or municipalities, or both combined, is called for.

Here is a work wherein soldiers in large numbers could be given profitable and congenial employment. After their experience in war, where men have been assembled in large numbers, the comparative isolation of farm life will be irksome to most of the returned men. After life in the open the confinement of factory or office will be equally irksome in many cases. Forestry work is done in the open, and considerable numbers can be associated together in that work. The life of the forester is one that should make special appeal to thousands of our men now overseas.

#### **Protection Alone Necessary.**

An extensive undertaking in planting is not necessarily called for, at least at the start. There are thousands of acres, with scattered timber, that need only to have cattle fenced out and fire guarded against to become dense forests of valuable timber in a short time. Even where planting is necessary it is not such very slow work. Two men, working at moderate speed, can plant an acres in a day with trees five feet apart each way.

But individual effort can be made to count as well. There are thousands upon thousands of farms with from two to ten acres of land that should be in bush. Thees for the planting of such farm wood lots can be had, free of cost, from the provincial forestry nurseries. If a thousand farmers could be induced to start such planting next spring they would do a good thing for themselves, a good thing for their neighbors, and their action might stimulate the provincial authorities to undertake forestry work on a province-wide basis.

### **AIR PATROL IN B. C.**

Victoria, B.C.—An average year of fire protection and control costs the province something like \$250,000 and in round figures one-fifth of that amount is absorbed by No. 1 Forest District, which embraces Vancouver localities and Vancouver Island. It was Hon. Mr. Pattullo's proposal to experiment in No. 1 District this year; but in view of the dangerous hazards he sees the necessity of maintaining the full regular service until the practicability of patrol from the air shall have been established. An approximate estimated cost of the first year's experiment—including the major portion of the initial outlays—in No. 1 District is placed at \$40,000, and the suggestion is that the province should contribute half and the Dominion the other half of the expense.

## WESTERN CANADA!—THIS IS YOUR BUSINESS!

### If Your Timber Resources Are Valued as Public Essentials, an Immediate Change in Dominion Methods is Due You.

Through the Canadian Forestry Journal, which regularly enlists the interest of more than two thousand public men in the three prairie provinces, and by various other channels, the long overdue change in public management of the choicest timber areas in the Middle West has been developed to such a point where postponement of the obvious remedy cannot prevail much longer.

By permission of the Parliamentary Committee on reorganization of the Civil Service, the Canadian Forestry Association will present a statement of its case at the Fall session of Parliament. It is noteworthy that the points contained in the Association's memorandum have never been discounted nor even seriously disputed from official or unofficial sources. Excerpts from the memorandum are as follows:

"The proposal we wish to bring before your committee in this instance is that the timber cutting operations on the licensed timber berths, which comprise the finest timber lands of the prairie provinces and the railway belt of British Columbia, should be brought into line with almost universal modern practice and placed henceforth under direction of the Dominion Forestry Branch. The latter represents the Dominion Government's forest conservation enterprise but at the present time has no actual authority over the really valuable timber of the Canadian West. Our reasons for this are of a specific and substantial nature. The public interest in maintaining a permanent timber supply transcends the interests of any commercial operator and is supposed to represent the motive of all Government administrators. The public interest requires that forest lands of no agricultural value shall be utilized for immediate requirements but with full provision for the maintenance of the capital values represented in maturing timber. In other words, the forest is to be regarded as a reproductive crop rather than a non-reproductive mine. This is the guiding star of all efficient European Governments and of the Government of the United States on the national forest domain.

#### What of the Future?

We are convinced that at the present time, the timber stock on Dominion lands, administered

by the Timber and Grazing Branch, is in a state of progressive depletion and that provision for future timber growth receives little, if any, consideration. While it is true a diameter limit is theoretically imposed upon all operators, this measure, even if enforced, is not in itself adequate to bring on a new forest. Each set of conditions within a forest area requires distinct forestry treatment, if conservation is to be more than a hollow term, and forestry is the business of technically trained foresters.

#### Get the Money—Lose the Forest.

We submit further that the present primary concern of the Timber and Grazing Branch is the collection of revenue, not the management of the country's timber supply on a basis of permanent production. For the latter responsibility, which takes precedence to the gathering of immediate revenues, the Timber and Grazing Branch has no administrative provision. It does not employ any forester, nor is there any means by which the staff of technical foresters of the Dominion Forestry Branch are given control of the work for which they are especially trained, and upon which they are already engaged as to lands in the Dominion forest reserves aside from the licensed timber berths.

#### The Example of Others.

The Dominion Forestry Branch was instituted as a conservation body to administer the timber resources of the West, not as a selling bureau, but to protect from fire and to build up the Western forests in the immediate and future interests of the Western people. Yet, the Dominion Forestry Branch and its constructive operations are restricted mostly to the poorest timber areas, while the main timber resources of the prairie provinces are thrown open to practically unrestricted exploitation.

The Provinces of British Columbia, Quebec and New Brunswick have taken action similar to that advocated for Dominion lands. In those provinces, the local forestry organization completely controls the administration of cutting on all Crown timber lands, whether licensed or unlicensed.

#### Undisputed Facts.

The Canadian Forestry Association has made these representations to your committee from a

sense of public duty and with regard only to facts which have been demonstrated to exist. We look upon the present situation as a departmental inheritance of the present Government which only awaits open discussion to be solved satisfactorily.

The Commission of Conservation has repeatedly urged upon the Dominion Government the necessity of applying the authority of the Dominion Forestry Branch to the technical operations on licensed timber lands. This would not necessarily dislocate the present organization of the Timber and Grazing Branch, but would, rather, initiate a line of work—technical forestry—which does not now exist, so far as licensed timber lands are concerned. It forms, in our view, a very simple method of fulfilling the obligation of the Dominion to handle the western forests in the best interests of the western people. The reading of Section 58 of the Dominion Lands Act would lead to the conclusion that action along this line was originally intended by Parliament.

#### Unequal Supervision.

As your committee is concerned also in the question of duplication within the Civil Service, it will, no doubt, give due attention to our argument that once the principle of expert forestry supervision on Dominion timber berths is endorsed, the Dominion Forestry Branch is obviously the instrument for the application of such a principle.

At present, the Timber and Grazing Branch maintains six timber agencies. The field inspection as to the carrying out of the timber regulations is done by Crown timber inspectors numbering about thirty-five. In many cases the work is combined with that of land inspection, and in any case such a staff cannot closely supervise lumbering operations scattered over more than six thousand square miles of country.

#### Foresters Available.

The Dominion Forestry Branch, on the other hand, has divided its field work into four inspection districts, corresponding with provincial boundaries. These are in charge of district inspectors, who with one exception are technically-trained men. The inspector is the business manager of the reserves in his district. Each district is subdivided into administrative units, each in charge of a forest supervisor, the latter also being with rare exceptions a technically qualified forester. Assisting the supervisor are one or more forest assistants, graduates of for-

estry colleges. The 1918-1919 field staff of the Dominion Forestry Branch consists of 4 inspectors, 15 supervisors, 5 forest assistants and 165 rangers, making a total of 189 men, under the supervision of a head office staff of technically trained foresters.

In tree-cutting in the crown forest Gullberg, in the province of Ostergotland, of south Sweden, there was cut down a 56 years old pine that bore a fresh living branch of spruce of 51 years at 5 feet from the ground. A nearer investigation showed that the spruce branch was really grafted on the pine in a natural way and has lived so without communication with the mother spruce at least 14 years.

## TREES FOR MEMORIAL PLANTINGS



Special quotations on quantity lots of  
Shade Trees, Weepers, Evergreens, etc.

Send for Catalogue.

## STONE & WELLINGTON

The Fonthill Nurseries

TORONTO

ONTARIO

### WOOD BLOCK FOR ROADS.

During 1919, according to conservative estimates, says the American Lumberman, contracts for the construction of \$600,000,000 worth of good roads will be let. The total value of contracts may exceed \$1,000,000,000. The good roads campaign this year is more than a State campaign; it is a national campaign, and it marks the beginning of the construction of good roads upon a most comprehensive scale. There was a time when the construction of steam railroads was the great construction effort of the day; now, however, the construction of good country roads promises to be the order of the day and exceed in magnitude and importance the building of steam railroads.

A properly laid road of properly treated wood blocks makes the finest and most durable road

possible. The interest of lumbermen, therefore, in the road construction programme is much keener than it would be viewed simply from a national development standpoint. The action of the West Coast Lumbermen's Association in agreeing to pay the difference between the cost of concrete and wood block paving on a stretch of road five miles in length on the Pacific Highway in Lane County, Oregon, is a well planned boost for wood blocks. The lead of this association can well be followed by other associations and by individual lumbermen or manufacturers of wood paving blocks. The construction of lengths of wood blocks in specific places throughout the country will certainly demonstrate their superiority over any other class of road construction, and will prove to the public that wood block roads should have a very important place in the national good roads construction.

## WESTERN AUSTRALIAN PUBLIC SERVICE PERMANENT POSITIONS UNDER THE PUBLIC SERVICE ACT.

Applications will be received until May 31, 1919, for the position of Working Plans Officer in the State Forestry Department.

Salary, £504-£636.

Applicants must be qualified foresters having a degree or diploma of a forest school.

G. W. SIMPSON,  
Public Service Commissioner.

Perth, Western Australia.

## STEEL BUNKS FOR CAMPS

Included in the well-known line of DENNISTEEL factory, hospital, camp and ship equipment is the all-steel sanitary bunk illustrated. Take up very little room, are comfortable, hygienic and practically indestructible—a permanent investment. Write for particulars and folders on any of the following lines: Steel Lockers, Bins, Cabinets, Chairs, Stools, Etc. Standardized Steel Shelving (knock-down system), Steel Hospital Equipment, General Builders' Iron-work. Ornamental Bronze, Iron and Wirework. Wirework of every description.

THE DENNIS WIRE AND IRON  
WORKS CO. LIMITED

LONDON  
CANADA

HALIFAX MONTREAL OTTAWA TORONTO  
WINNIPEG VANCOUVER

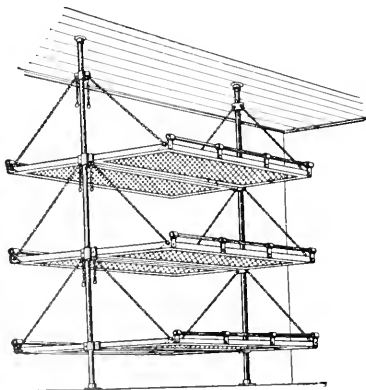

# CLEARING THE FOREST OF DEBRIS

By Ellwood Wilson, Laurentide Company.

## Can Fire Rangers be Used in Winter to Follow Crews and Eliminate the Slash?

The one thing that every fire ranger fears is a large fire in cut-over lands, which, fanned by a high wind, will attain such proportions before help can be obtained that many square miles will be burned over before it can be stopped. Single fires in the past have gone over tracts of 1,000 square miles and with weather and wind conditions favoring, the same thing could possibly happen again. How can we prevent this?

The records of fires for six years past, show that the majority of fires occur in cut-over territory and on old burns. That means that cut-over territory is responsible for the greater majority of the fires, for this burns over and the land so burned catches fire very easily for at least two successive seasons after the first burn. Of the area burned over each year about forty per cent is cut-over territory and forty-two per cent old burn, making a total of eighty-two per cent chargeable to the lumber operations. Practically all of the fires which require labor other than that of the rangers to extinguish start in cut-over or burnt-over lands.

### Logging Areas.

The way to eliminate these fires is to burn the debris from logging at the time the logging is done, or shortly after. This will cost some money, but will materially cut down the cost of fire protection, and in time, cut down the cost of patrol so that it is probable the increase in expense would not be large. Then to, the value of the forest lands would continually increase, as now timber left after logging is destroyed by fire, and once burned over, the lands are very liable to burn over again, destroying the seed stored in the soil and postponing the reproduction of valuable kinds of trees for many years. This burning of the brush might logically be left to the logging crews, but it has been shown that anything that adds to the cost of making logs is violently opposed by woods managers and their staffs, as their efficiency is judged by the price

at which they are able to deliver logs and they do not consider that it is their business to do more than cut and haul the logs.

### Fire Rangers Available.

If this cleaning up were made part of the fire protection work, it could be done by the rangers in winter, by men who understand how to handle fire in the woods, and who understand the danger of it. These men could follow the loggers and pile and burn the brush, so that when spring came, the danger from the cut-over debris, would be entirely eliminated. Of course it would be necessary to apportion the cost to the different operators on the basis of acreage, but this would not be difficult and the measurement of the amount of land cut-over each year would be of an immense value to the holders. Lands so handled would immediately begin to reforest themselves to the great benefit of the holders and of the country in general. By preventing the burning of these lands they would reproduce the valuable species instead of coming up in poplar and jack pine, as they now do after fires. Many years in the regeneration of these lands would also be saved.

Insect and fungus enemies of forest trees are spreading at an alarming rate and are now probably as serious a menace as forest fires. It has also been shown that burning the logging debris is one of the best possible ways to eradicate these pests so that from every point of view it seems that slash burning should without delay be made a part of our protective work.

It may well be asked if burning is the only way of disposing of logging debris. Taking out logs down to three inches top diameter would help the situation and would reduce the waste. Top-logging has been tried and found to cost about 40 to 50 cents per thousand feet board measure of logs cut, but the fire hazard is very little reduced. The advantage is that the brush rots quicker and so the land is not in a dangerous condition for as long a time as with unlogged tops. This does not do away with

the feeding ground which the decaying brush forms for borers and other insects and fungi.

### Piling and Burning.

Piling and burning seems the only solution of the problem. In cleaning up lands for planting operations, this has been used for the past four years, but the amount of debris both hardwood and softwood is far larger than in ordinary logging operations, and the cleaning up much more thorough than in logging is necessary. The usual method employed in winter operations is to have a boy with every four choppers who takes the branches and tops as they are cut and starting a fire throws them on it. The brush both hard or softwood burns without any difficulty regardless of the amount of snow. In logging when there is no snow on the ground the helper piles the brush and these piles are burnt on rainy days or after the first snow. A flame-thrower burning kerosene has been developed and will be used in this work. It can be carried by one man and has two hoses which allow two streams of fire to be thrown at once. It may prove to be possible with this machine to burn brush just as it is cut without throwing it into large piles, the result of this burning as far as the condition of the wood is concerned afterwards is eminently satisfactory. The fire hazard is reduced by at least 75 per cent, the ground is clean and reproduction of young growth starts immediately, and the young trees left by the operation commence to make rapid growth owing to letting in of more light.

### The Question of Cost.

This is the most important step which we can possibly take in forest protection, and it has been recognized as such in the cutting regula-

tions of the United States Forest Service and has also been imposed by the State of New York in a modified form on timber operators. It is better to undertake this in advance of pressure from public opinion, and hold our position as leaders of thought and promoters of the general public welfare.

The cost of slash burning in the St. Maurice Valley runs sometimes as high as 20 to 25 complete clearing on private lands in preparation for planting. Naturally there is not much commercial timber on such lands and the situation is quite different from a timber limit where the hardwoods are not logged.

There is one situation that I think is improving, i.e., the closer cutting than we had in the past. We do not cut our timber any deeper now than we did years ago. The quantity left in the woods to-day is very small compared with that left a few years ago. Over fifty per cent less. I agree with the idea that is a good thing that a committee is appointed to look into this matter of slash burning. If we could get a number of practical lumbermen that would agree next year and who would set aside one camp who will burn their slash and let other operations go on in the same way. Then we would be able to get exact facts as to the destruction caused by the burning of slash. I will agree to do this with one of my camps for one.

Mr. McLean: Practical lumbermen are interested in the disposal of slash. Lumbermen have the greatest interest in protecting the forest. It is their livelihood. I have not yet had any experiment made by my men as to the best way to get rid of slash, so have no definite plan.

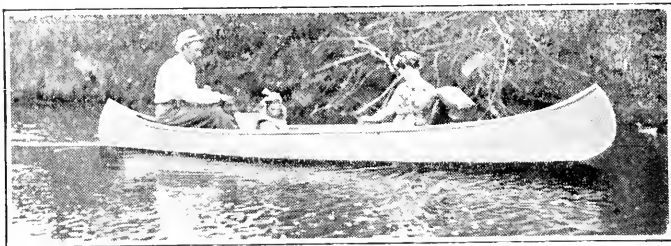

THE FAMILY CANOE  
Paddling is a most pleasant summer pastime. It delights the old and the young. --

CHESTNUT CANOES  
are the ideal canoes for everyone. They are staunchly built for comfort, strength, and durability. The rib work and lining are made of toughest New Brunswick Cedar—The whole body is covered with a seamless sheet of specially-woven canvas treated with a very efficient water-proofing preparation. A Chestnut Canoe is leak-proof and safe.

The Chestnut Pleasure, Sponson, and Cruiser Canoes are the best canoes for any kind of aquatic sport or pastime.

THE CHESTNUT CANOE CO., LIMITED.

BOX 460, FREDERICTON, N.B.



## FOREST TELEPHONES

Make the life of the forester better worth living. They relieve him from the appalling loneliness. They help him to keep in human voice touch with foresters miles away.

In emergencies—fire—sickness—hunger—the speed with which they can summon help is marvellous.

Write for full particulars of how to install the Northern Electric Forest Telephone System. Address the Office nearest you.

*Northern Electric Company*  
LIMITED

|          |          |           |
|----------|----------|-----------|
| Montreal | Toronto  | Regina    |
| Halifax  | London   | Calgary   |
| Ottawa   | Winnipeg | Vancouver |

***Northern Electric Forest Telephones***

## Foresters' Equipment

---

MOSQUITO AND INSECT PROOF TENTS  
WATER AND MILDEW PROOF BAGS  
FROST PROOF SLEEPING BAGS  
ALL "WOODS" QUALITY

---

## Woods Manufacturing Co.

DEPT. D.

OTTAWA

**TREES, SHRUBS and SEEDS**

HARDY NORTHERN TREE STOCK

**EDYE-DE-HURST & SON, DENNYHURST**

DRYDEN, ONT.

Shippers to H.M. Government.

**GAGNON & MORISSETTE**

TIMBERLAND CRUISERS

LUMBER CONTRACTORS

FOREST INDUSTRIES

CHICOUTIMI, - - P.Q.

**Hill's Seedlings & Transplants**

ALSO Tree Seeds for Reforesting. Best for over half a century. Immense stock of leading hardy sorts at low prices. Write for price list and mention this magazine. Forest Planters Guide Free.

**The D. HILL NURSERY CO.** Evergreen Specialists

Largest Growers in America. Box 503. DUNDEE, Ill., U.S.A.

**LT.-COL. L. J. D. MARQUIS**

Forest Engineer and Mem. Can. Soc. of F.E.; Quebec Assoc. of F.E.; Former Mem. Que. F. Service

Timber Factors and Logging Costs  
Facts on Forest Growth and Future Products  
Forest Cruising and Mapping  
GIFFARD, - - - - QUEBEC.

**Try This Stump Puller at Our Risk**

The Smith Stump Puller will take out every tree and stump by the roots, clearing from one to three acres a day, doing the work of twenty men. We want you to send for our 3 year guarantee against breakage and our free trial proposition. Address W. Smith Grubber Co. 11 Smith Sta. LaCrescent, Minn.

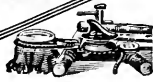

**Timber Lands Bought & Sold**

Timber and Pulp Wood Estimates.

**R. R. BRADLEY**

CONSULTING FORESTER

Globe-Atlantic Bldg. - ST. JOHN. N.B.

ASK



FOR



**Timber Estimating & Mapping**

Management of Forest Properties.  
Supervision of Lumbering Operations.  
Forest Planting.

**COOLIDGE & CARLISLE**

FOREST ENGINEERS

BANGOR - - - - MAINE.

**Timber Estimates**

JAMES W. SEWALL

Old Town, Maine.



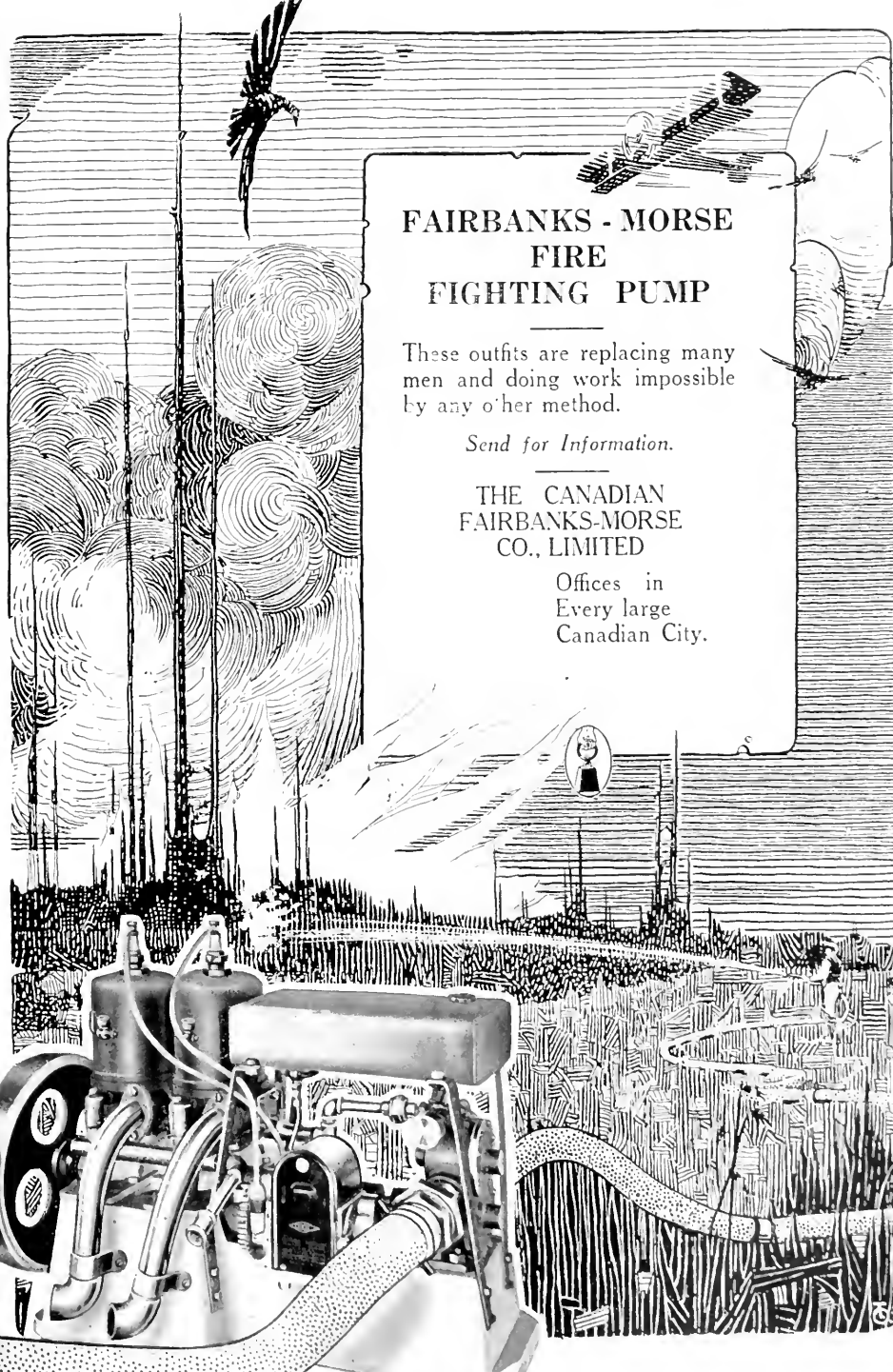

**FAIRBANKS - MORSE  
FIRE  
FIGHTING PUMP**

These outfits are replacing many men and doing work impossible by any other method.

*Send for Information.*

**THE CANADIAN  
FAIRBANKS-MORSE  
CO., LIMITED**

Offices in  
Every large  
Canadian City.

## CONFEDERATION LIFE ASSOCIATION

### UNCONDITIONAL ACCUMULATION POLICIES

Are liberal up-to-date contracts which guarantee to the insured every benefit consistent with safety.

#### WRITE FOR PARTICULARS

which will gladly be furnished by any representative of the company or the

HEAD OFFICE,  
TORONTO



QUEEN'S

UNIVERSITY

KINGSTON,  
ONTARIO

ARTS

Part of the Arts course may be covered by  
correspondence.

MEDICINE      EDUCATION  
APPLIED SCIENCE

Mining, Chemical, Civil,  
Mechanical and Electrical  
Engineering

SUMMER SCHOOL      NAVIGATION SCHOOL  
July and August.      December to April

26      GEO. Y. CHOWN, Registrar.

## R. O. SWEEZEY

(B.Sc., M.E.I.C.)

WATER POWERS.      TIMBER LANDS.  
FINANCING

164 St. James Street - MONTREAL.

## P. L. BUTTRICK

CONSULTING FORESTER

NEW HAVEN, CONN., U. S. A.

P.O. BOX 607

---

TIMBER ESTIMATES  
UTILIZATION STUDIES  
PLANTING PLANS

---

Landscape and General Forestry Work.  
Eight years experience in practical  
forestry work of all sorts.

## UNIVERSITY OF NEW BRUNSWICK

FREDERICTON, N.B.

### DEPARTMENT OF FORESTRY

Established in 1908.

Best of facilities for definite instruction  
and supervision in Practical Forestry.

Surveying, cruising and construction  
work carried on in our own tract of 3600  
acres, with Forestry Camp in the centre.

Competent men from the School at  
present in demand to take up Forest Sur-  
vey work with the Provincial Crown Land  
Department.

For further information address:

### DEPARTMENT OF FORESTRY

University Calendar furnished on application.

C. C. JONES, *Chancellor.*

## TABLE OF CONTENTS FOR JULY, 1919.

|  |     |
|--|-----|
| Planting Suitable Shade Trees. By F. E. Buck.....                  | 291 |
| Trimming and Re-trimming Roadside Trees.....                       | 295 |
| Change Quebec's Cutting Regulations.....                           | 296 |
| Linemen and Shade Tree Slaughter.....                              | 297 |
| The Cash Value of Shade Trees.....                                 | 297 |
| Public Necessity and Private Rights.....                           | 301 |
| Technical Men Wanted in the Woods.....                             | 302 |
| The Forest's Losing Fight in Arctic Canada. By Frits Johansen..... | 303 |
| Passing of the Balsam Budworm in N. B. By J. D. Tothill.....       | 306 |
| A Question for New Brunswick. By Angus McLean.....                 | 308 |
| Tree Planting Work in Quebec.....                                  | 309 |
| Ontario's Forest Possessions.....                                  | 310 |
| Can Timber Limits be Mapped by Airplane?.....                      | 312 |
| Making Forestry Pay its Way.....                                   | 314 |
| Building a Nation on a Tree Farm.....                              | 315 |
| Ontario and New Brunswick Forest Fires.....                        | 320 |
| Western Canada!—Is This Your Business!.....                        | 324 |

WANTED

## LIGHT RAILS

State whether complete with  
splice or angle bars.  
Give size, quantity, location,  
condition and best cash price  
f. o. b. cars loading point.

Box No. B, Canadian Forestry Journal,  
Ottawa, Can.

## B. M. McGRATH

Colonial and Industrial Investments,  
Timber, Pulp Wood Areas and  
Waterpowers.

Newfoundland and Labrador  
Mines and Minerals.

*Reports, Plans and Estimates Furnished*

TRADE REVIEW BUILDING,  
ST. JOHN'S, NEWFOUNDLAND

MOTION PICTURE  
MACHINES

## STEREOPTICONS

We are fully equipped to  
supply projection  
apparatus on short notice.

LANTERN SLIDES and  
Motion Picture Film made  
up in twenty hours.

Write for Catalog.

PROJECTION DEPARTMENT  
SUPPLIES COMPANY  
OF CANADA

65 SPARKS STREET,  
OTTAWA, ONT.

# “SHAKE HANDS WITH THE TREES”

*Can You Speak to a Tree-Family by Name?  
Do You Know the Wild Animals by Sight?*

If you only know a summer woodland as “a bunch of trees” you have not yet made a nodding acquaintance with Canada’s great outdoors.

When you can say “That’s a lovely spruce!” “Hello! what’s a tulip tree doing in this part of the country?” “Notice the perfect form of that Norway Maple!”—Then only will you know the delights of a walk in a midsummer woodland.

## *How to Make a Lifelong Acquaintance*

One copy of “The Tree Guide”, a handsome little book of 265 pages, copiously illustrated in color and in black and white from photographs, linen covers, easy to read and hard to forget—really a fine companion for man, woman or boy. Written by a noted authority, J. E. Rogers. **Price, post free, \$1.00.**

One copy of “The Animal Guide”, almost identical with the “Tree Guide”, but with sixty illustrations, all in natural colors. Written by Chas. K. Reed, the Naturalist. Non-technical and appeals to children as well as grown-ups. **Price, post free, \$1.00.**

One copy of “Game Birds”, bound in boards, one hundred species in natural colors. Very readable and highly accurate. **Price, post free, Fifty cents.**

**THE THREE BOOKS ARE OFFERED AT AN INCLUSIVE PRICE OF \$2.25.**

# Canadian Forestry Journal

206 BOOTH BUILDING

OTTAWA, CAN.

IF YOU WANT A CHEW  
THAT WILL JUST SUIT

YOU ASK FOR

**STAG**

**CHEWING TOBACCO**

RICH AND SATISFYING.

IT IS ALSO KNOWN TO BE  
"EVER-LASTING-LY GOOD"



## Do You Require More Capital?

For ten years, Royal Securities Corporation has been associated with the development and financing of Canada's most successful pulp and paper enterprises. Among them are:

*Abitibi Power and Paper Company.  
Brompton Pulp and Paper Company.  
Mattagami Pulp and Paper Company.  
Price Bros. and Company.  
Riordon Pulp and Paper Company.  
Fraser Companies, Limited.*

Do you desire to pay off floating indebtedness; increase your plant capacity; or acquire additional properties? If so, why not let us suggest ways of financing your requirements? Our Engineering and Statistical Departments are at your disposal.

## Royal Securities Corporation Limited

164 St. James St.,  
MONTREAL

58 King St. West,  
TORONTO

# Canadian Forestry Journal

September, 1919

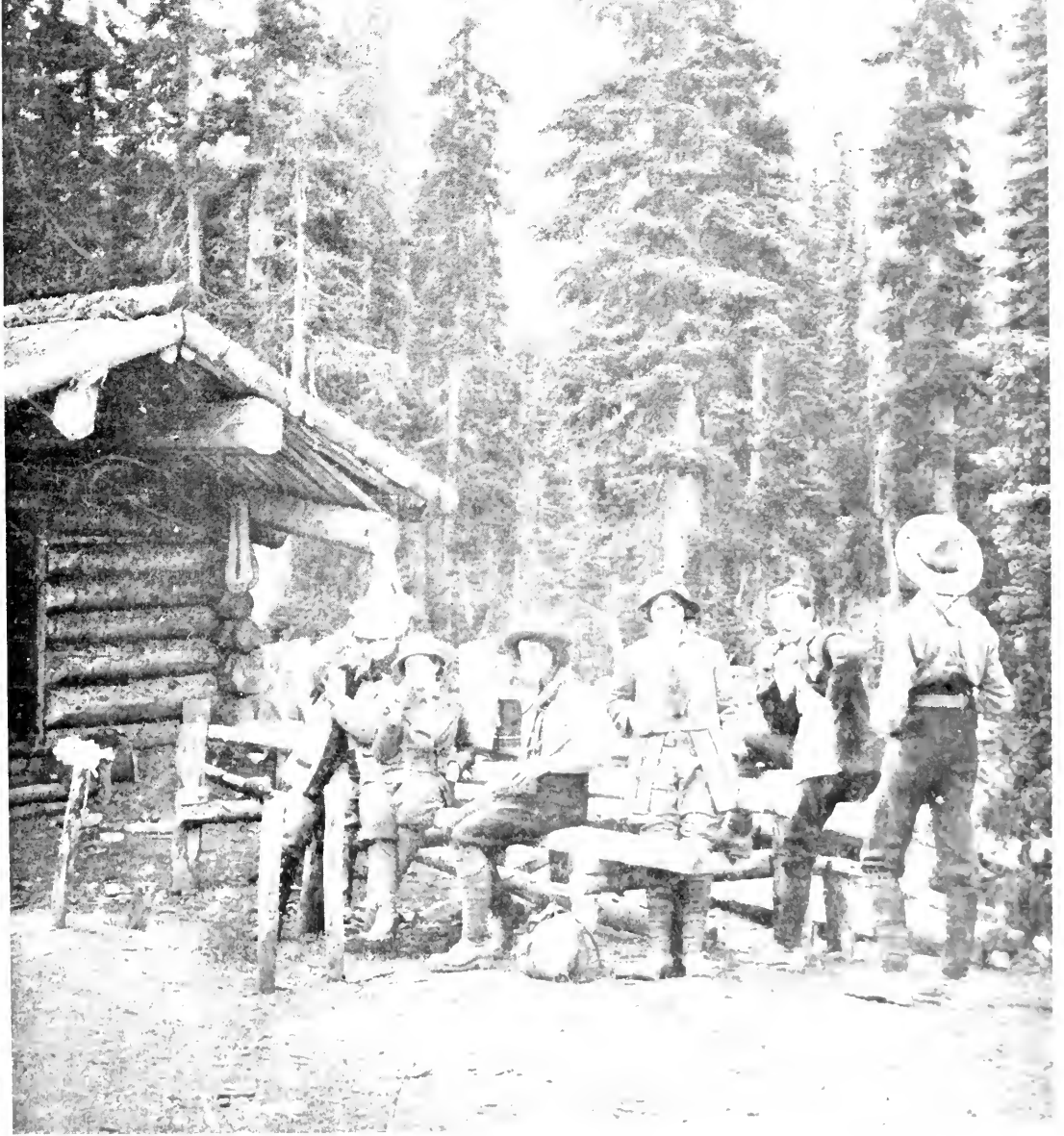

WITH THE ALPINE CLUB IN BRITISH COLUMBIA.



# Webster On "Morale"

*MORALE (Mo-ral) n. (F. See Moral, a.) the moral condition, or the condition in other respects, so far as it is affected by, or dependent upon, moral considerations, such as zeal, spirit, hope and confidence; mental state, as of a body of men, an army, and like.*

*N. Webster*

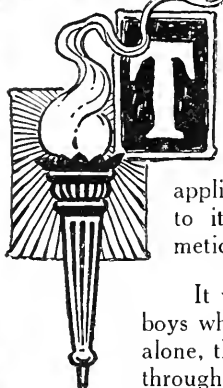

**HAT** is Dr. Webster's definition. Many of us know the word only in its war-time application.

Webster dwells firstly upon the usage of the word "morale" as applied to the common-place happenings of every-day life. His allusion to its reference to an army comes later. And Webster is correct—meticulously so.

It was their private-life morale that made such splendid soldiers of our boys when the time came for them to don the khaki. It was that, and that alone, that made them take the first step, and it was that which carried them through to victory. If their every-day morale had been neglected, the Army could have done little with them and success would not have crowned their efforts.

It is the many little incidents of your daily routine that make up your morale—the morning shave, your clean linen, polished shoes, brushed clothes. Webster speaks of zeal, spirit, hope and confidence. It is by attention to the small details of your personal appearance that these may be attained.

The Gillette Safety Razor enters as much into the morale of everyday life as it did into that of the trenches. It helped our soldiers to maintain their confidence and bearing. It will do the same for you. The Gillette Safety Razor makes the daily shave come easy—there is no pulling or scraping—no honing, or stropping—just five minutes of perfect shaving comfort. And, afterwards, a chin that tells of morale and self-respect.

Sold at most stores catering to men's needs.



The Gillette Safety Razor Co. of Canada, Limited, Montreal, Que.



# Canadian Forestry Journal

VOL. XV.

OTTAWA, CANADA, SEPTEMBER, 1919.

Nos. 8 and 9.



English Sparrows appreciate bathing and drinking facilities as much as do more desirable species.

## HOW TO ATTRACT BIRDS TO THE HOME\*

By P. A. Taverner.



### Arranging Nesting Quarters, Guarding Against Trespassers, Providing Food During Fall and Winter Seasons.



When poor Tom Paine wrote "Home Sweet Home," he sounded a note that found an echo in every human heart. In the second stanza he wrote:

"The birds singing gaily,  
That come to my call";

thus suggesting the intimate association existing between the sticks and stones of that which we call "Home" and its animate surroundings. In fact "Home" is not merely that shell of brick and wood and plaster in which we abide and the ground that surrounds it, but includes also a host of associations of which we consciously or subconsciously feel the influence. A home without these delicately haunting memories is but a name, and one of the essentials to home building and the development of its higher refining influences is the creation of these subtle

intangibles that after all finally rule the world. That birds are not the least important of these influences is declared by all the poets and is confirmed by our own experience. In the days of careless childhood or busy young manhood, we may not have particularly noted the common birds about us, but in after life they have made an indelible impression when the twittering of a flock of swallows takes us back to the old hay-mow with its attendant flight of birds or the chatter of the kingbird reminds us of the orchard with its refreshing shade and its noisy guardian driving off intruders.

From the purely esthetic side therefore, the encouragement of birds about the home and the introduction of the impressionable child mind to them makes for stronger home ties and a better coming generation, while the benefit of having numerous feathered allies in our constant fight against insect pests must be ac-

\*Published by permission of the Geological Survey, Canada.

cepted as economic justification for attracting birds by the most hard-headed and practical man of material affairs.

### The Investment in Bird Beauty.

As a rule he who gives nothing receives nothing in return. If we want birds intimately or permanently about us we usually have to give them something in return. However, the price is small and can be paid without impoverishing ourselves and the returns are large. Food, water, protection, and nesting sites include practically all their requirements and when we supply these they ask no further price but come freely to our assistance and pleasure with all their charming personality and melody.

Of these requirements that most commonly and easily furnished is the nesting site. In these days of intensive cultivation, when even the trees have their surgeons and every rotting or hollow stub or branch is filled with antiseptic concrete, many of our best bird friends are hard put to find suitable cradles for their young. If we remove or destroy their natural nest receptacles, it is no more than fair that we should supply artificial ones. At any rate in the reproductive season such situations are absolutely essential to the presence of birds in any locality. Of course, not all species require such cavities and branches of trees with convenient forks are all that many need as foundations for their nests. To others, however, and amongst them some of the most attractive species, such cavities are absolutely essential. In Canada, such species include, the Purple Martin, Tree Swallow, House Wren, Bluebird (both eastern and western forms), Crested Flycatcher in the east and the Arkansas Kingbird in the west, the woodpeckers including the Flicker, nuthatches and chickadees as well as the Screech Owl and the Sparrow Hawk. The inclusion of these two birds of prey as desirable tenants may cause some surprise, but the Screech Owl is a notable mouser, the equal of several cats, and does much more good than harm. Besides it is a most interesting little fellow and, where small bird welfare permits, a most desirable neighbor. Its soft tremolo notes, libelously called "screech," is a pleasant sound to have drift in on one through the darkness and adds a charm to the night that is only otherwise supplied by the mournfully lonely whippoorwill or the occasional night song of other species. The Sparrow Hawk is an even less doubtful character. As a grasshopper destroyer it deserves every encouragement in the vicinity of cultiva-

tion, and as a mouser it is not to be despised. The building of bird houses is too long a subject to go into its details here, but a discussion of the subject with plans and drawings of different types of bird houses will be forwarded to any reader interested in the subject on receipt of a post card addressed to the writer, care of the Geological Survey, Ottawa.

### Water for Bath and Drink.

The next great attraction to birds is water. In the hot dry days of summer water is often scarce, and birds have frequently to go far for the moisture necessary to them. No elaborate receptacle is necessary to contain it. The main requirements are that it is changed often enough to be fairly fresh, is shallow enough that they can bathe in it, and that it is well out from cover that may hide lurking enemies, cats for instance. A flat pan set on a small slope so that it is shallow at one end is sufficient to attract numbers of birds. More elaborate containers can be used; from rough concrete slabs, made picturesque with rock as ingenuity suggests, to highly sculptured bird baths of monumental character, or larger tanks or water-gardens in which lilies and lotus may be grown and which may have bird requirements provided for in their construction. It is astonishing how many birds such a grateful supply may attract. The robins are particularly constant visitors to water and it is no uncommon sight to see half a dozen awaiting their turn for a bath or a drink. Sometimes each will be impatient of the presence of the others and sometimes a procession of them may be seen chasing each other about the bath too occupied with driving off intruders to attend to the real business for which they came. Song sparrows will visit the water regularly, splash a while in the grateful coolness, come out and preen, and then return for another dip. Afterwards their song of happiness from some nearby vantage point is ample repayment for the slight trouble it has cost. Kingbirds, Orioles, Chippies, Yellow Warblers, Goldfinches, all come in succession to the water, some making prolonged visits, others alighting for a moment like the Goldfish for a sip and then off again with undulating flight and merry little oft-repeated "per-chick-o-pe." Occasionally, depending upon surroundings, other birds pay visits. The Flicker once in a while deigns to drink and unless restrained Bronzed Grackles keep the other birds in continual uproar with their undesirable presence. Swallows dip into it if the water is expansive enough and I have even



A Cedar Waxwing sunning itself on a fence post.

known Bitterns to be momentarily attracted by a small artificial lilly pond in the city outskirts.

### The Search for Sanctuaries.

Next to water comes protection as a factor in attracting birds. The life of wild things is one continuous watchfulness against danger. Their enemies are innumerable and their personal histories are little more than a sequence of escapes. They discover isles of safety as it seems that they associate locally with danger and soon learn to avoid spots where they have been repeatedly endangered. Under these circumstances it is hardly surprising that a place where they can lay aside some degree of their ever watchful constraint has an attraction for them, and it is surprising what results where protection from enemies will produce. To see

hundreds of wild geese, the wariest birds, as tame as barnyard poultry at Jack Miner's place at Kingsville, Ontario, simply because they know they are safe, is an object lesson. In Meriden, New Hampshire, through co-operation throughout the village, all the birds are equally tame; come to the hand and be fed, and show a confidence in man and his protection that is more like the Golden Age than this one of Steel and Iron.

### Beware the Cat!

Principal among the bird dangers to be guarded against in settled communities, is the common domestic cat. The toll taken by gentle pussy from bird life is, in total, enormous. No cat but is a hunter on opportunity. Even the best of care and feeding fails to restrain the feline nature in this direction. Of course hungry cats who have to hunt to live, kill more birds than the pampered pets, but not even the aristocratic Angora or Persian is guiltless. How to control the cat is rather a difficult problem. A cat-proof fence about the grounds is the most satisfactory method. High fences of poultry wire, or topped with the same with an outward flare of eighteen inches left loose and flapping is usually sufficient. When old fishnet can be procured, a three-foot strip strung along the top of the fence supported loosely by lath supports at wide intervals, is unclimbable by cats and will keep them out. The most desirable solution of the cat problem is undoubtedly a cat license. We should no more tolerate a lot of underfed, ill-kept cats, living by their wits, than we do a number of ownerless dogs. If anything, cats are a greater danger to the community. Rabbits amongst dogs is a very rare disease, but the cat's potentiality for the spread of disease is great indeed, as they prowl everywhere and come closer in contact with us, hugged and kissed by the children, nesting in the woodshed corners in unexpected places, and



Cuckoo Robin takes his morning tub.

even licking the top of the early morning milk bottle. However closely a house is quarantined there is one member of the family that comes and goes at will, and that is the cat. However, pussy is too old a companion, I almost said friend, of man to be lightly dismissed. The cat purring on the hearth rug is almost an essential to a real home, and the pleasure she gives the little ones is too real and human to be disregarded. As a mouser or rather the cat is not efficient. No badly infested locality was ever cleared of such vermin by cats. When San Francisco inaugurated its crusade against rats the cat was found useless and not until systematic trapping and rat-stopping was inaugurated was headway made against them. Any one should have a family cat, if they wish, but if they do not want them enough to pay a nominal registration fee their desire is not enough to balance the very real menace they constitute. Such a registration fee would prevent none who really desired from having their pets, but would control the host of half-starved felines that now infest our alleys and vacant lots.

#### Early Morning Perils.

Various methods have been suggested to prevent cats from catching birds, such as putting a bell on them or even the use of a tether. Neither of these or many other schemes so far proposed, have worked out in practice. The most practical plan is to keep the cat in at night or rather in the early morning, only letting her out after the dew is gone. Most cats kill practically 90 per cent of their birds in the early morning hours when morning hunger reduces caution and when chilled by the morning air, and wet with the dew from foliage, birds are slower in motion and less on guard. If the cat is kept in until the birds have resumed their usual daily attitude of watchfulness it will do but a small amount of harm.

Of course the small boy with the sling shot, air gun, or small rifle, have obviously to be guarded against, but their case is comparatively easy. Other enemies of common garden birds are the Blue Jay, Red Squirrel and Bronzed Grackle. These are all confirmed nest robbers and are not adverse to taking adults upon occasion. The saucy Red Squirrel is particularly pernicious and though we cannot help admiring his spritely ways and intelligence, he should not be allowed to increase unduly. An occasional squirrel adds an interesting though peppery personality to the landscape, but too many of them mean no birds. A choice must be made be-

tween the two, we cannot have both in abundance.

#### Fighting the Sparrow.

The Blue Jay is not likely to disturb the garden community as it usually keeps a little farther away from the immediate vicinity of man and his works, but the Grackle is especially fond of the ornamental evergreens and constantly invades the garden. No one can observe the wild protests its presence arouses in all the garden inhabitants in nesting season without realizing that it is undesirable there. Besides it is gratingly noisy and a very dirty nest-builder, filling the trees or the cornices of the house with even more bulky masses of rubbish than the English Sparrow.

Under the head of protection this little undesirable importation should also be mentioned. Originally imported to control insect pests, it turned out more of a seed than an insect eater, and whilst driving away our native insect destroyers failed to more than partially fill their place, leaving us worse off than before. It drives away more valuable species in three ways. First by being early on the ground in the spring and pre-empting desirable nesting sites, second by competing with them, during nesting season in the common food supply necessary for all nestlings, and third by their aggressive and quarrelsome nature making an eternal hubbub and inducing more peaceably inclined neighbors to seek quiet life elsewhere. For these reasons English Sparrows should be kept under control and especially out of the nesting boxes until more desirable tenants have established themselves. After this less attention may be paid to them.

#### Winter Supplies of Food.

The question of attracting birds by food is mostly a winter problem. During the summer food is plenty as a rule and does not have to be supplied. A few berry-bearing shrubs will attract many species, and also serve to protect early fruit from their attack. Wild Cherries, Bush Honeysuckle and Mountain Ash or Rowan trees will attract numbers of Robins, Cedar Birds and others. A few heads of lettuce allowed to run to seed or fruiting annual Larkspur are attractions to Goldfinches, whilst a row of seeding Sunflowers is a never failing lure to many species in summer and autumn. It is in the winter, however, when birds and food are scarcest that the greatest results come from feeding. Grain, seeds, suet and nuts are great attractions, and many methods have been

evolved for distributing and displaying them. Scattering on the ground is wasteful as it is soon covered by snow and is not found by inhabiting species. Shelters can be made where ground feeders can be fed and the food protected from snow. Shelves can be set on low posts, some times with weather vane attachment to present the shelter to the storm. Mixture of various food components with suet, or suet alone, can be tied to tree branches or fastened with various devices. Window shelves are also popular as feeding stations as they bring the hungry banqueters close under observation and are easy to renew or keep free of snow. To list and describe all the details that

ingenuity have found practical for this work would take much more space than can be spared here. Fuller information can be found in other publications, notably those published by the United States Department of Agriculture and by the Commonwealth of Massachusetts, which can be obtained at a nominal cost. I would particularly like to recommend Harold Baynes' *Wild Bird Guests*,\* a perusal of which with its practical demonstration of what may be accomplished is an inspiration and example to all who love nature and desire to have her on friendly terms about them.

\*Published by A. E. Dutton, New York.



Stubs, like those in the photograph at the left, prevent the bark from growing over the wound and healing it, as it is doing in the centre picture. The bark wound at the right is healing properly, and in a few years will be hardly noticeable.

## THE CARE OF BARK WOUNDS IN TREES

By C. L. Meller.

Bark wounds endanger the life of a tree more than most people realize. This is due to the fact that all the nourishment the tree receives is carried in the thin green layer just under the bark. When the bark is injured, the flow of the sap in the green, or cambium, layer is stopped, and the tree fails to receive the proper nourishment. Bark wounds may be of many kinds, but among the most serious are those caused by cutting off limbs improperly.

In removing a limb, the cut must be made as close to the trunk or branch from which the limb grows as is possible. If the work is done so that a stub remains, it is impossible for the bark to grow over the cut end. The stub then dies and the decay is carried into the trunk or branch itself. By cutting the limb off close to the trunk, the new bark, with the cambium layer underneath, gradually grows inward over the cut part, in a narrowing circle, until the

wound is completely covered with bark, and thus protected. For added protection, while the healing process is going on, the exposed wood should be given a heavy coat of good paint. This should be repeated as often as necessary, until the wood is entirely healed. When this is properly done, healed wounds are difficult to detect.

Many wounds are caused by horses rubbing against trees used as hitching posts. Others are caused by sharp objects tearing off pieces of the bark. When neglected, these wounds permit decay as readily as do those caused by cutting off limbs in the wrong way. All loose or torn bark should be removed from such wounds, and the exposed wood given as smooth a surface as possible; also, the sound bark surrounding the exposed wood should be cut so that it has a continuous smooth edge. The outline of the area cut away should never be square, but should come gradually to a point at the top and bottom of the wound. Cutting the bark in this way allows the sap to flow freely around the wound and thus easily nourish the new bark that is forming.

Water must not be permitted to gather in the wound, under any circumstances, as it always hastens the decay of the remaining wood. A small groove cut into the lower end of the wound will allow the water to trickle away as rapidly as it collects. To protect the exposed surface better, it should be given a good coat of white lead or other available paint. One coat will not last all the years it takes for such a wound to heal; the wound should be given a new coat of paint whenever the previous one is worn out.

Properly treated, bark wounds will not seriously endanger the life of a tree. Repairing damages after the wood has had a chance to decay deeply is a very different matter. The same principle of removing all injured or decayed wood and bark, and preparing the surface to exclude water and to permit rapid growth of new bark, applies to the advanced condition. The photographs show bark wounds in various stages of healing, also stubs of limbs which were not cut off properly.

---

## New Books on Forestry.

---

Forest Management, by A. B. Recknagel, B.A., M.F., Professor of Forest Management and

Utilization, Cornell University, and John Bentley, jr., B.S., M.F., Assistant Professor of Forest Engineering, Cornell University. A condensed and simple treatment of the subjects, Forest mensuration, Forest organization, Forest finance and Forest administration, written in such a manner as to be readily understood and used by the layman timber owner and manager. Non-professional students of forestry in colleges and universities, and in professional courses not of post-graduate grade, will also find it of value as a text. In fact, the book occupies a middle-ground between the highly technical and the very elementary textbooks extant. Intelligent study of the principles advocated in this book will stimulate the practice of forest management by owners of timber land large and small, public and private to the end that this important natural resource may be systematically maintained and developed. 267 pages, 6 by 9, 26 figures, cloth, \$2.50, net (11s. 6d. net).

---

## SOCIAL SERVICE BY PAPER COMPANY.

---

The Laurentide Company is more than a manufacturing concern. From the last copy of *Le Digesteur* it is seen that they are encouraging the proper care of babies and the admission of fresh air to houses by printing descriptive pictures. They also conduct a class for the little housewives. More than forty are enrolled.

---

## A SETTLER'S EXPERIENCE.

---

A settler named Olson and two others of the Haileybury, Ont., district, had a trying experience. They sent their women folk out when the fire drew near. The Olson home was first surrounded by the fire and the other two went to help protect it. Olson got on the roof and pulled up pails of water which the two below carried to him. The nearer the fire got the hotter it became. Finally the house was completely surrounded and the dense smoke made it impossible for the trio to escape. It then became a battle for their lives, and those depended on their keeping the house from burning. It soon became so hot that the skin on Olson's face as he sat on the roof began to peel. He maintained his position by dumping every second pail of water over his body. They won the fight, but suffered terribly.



No housing problems in Spanish Honduras. Photograph shows homes of native Carib Indians, beside cocoanut palms.

## CRUISING MAHOGANY IN CENTRAL AMERICA

By L. C. Tilt, B. Sc.F., Formerly of Dominion Forestry Branch, Winnipeg.



### A Unique Journey Into Spanish Honduras in Search of Precious Woods—A Lazy Population.



Due to the proximity of New Orleans to Central America, that port has secured a large part of the trade carried on between the independent states of Central America and the United States. In consequence of this trade good accommodation can be secured on the steamers carrying machinery, etc., to these countries and returning with fruit, sugar, hides and timber.

I left New Orleans on a steamer of about 4,000 tons and after three days arrived at La Ceiba on the north coast of Central America, due south of New Orleans. From here a small government gasoline launch was taken to Truxillo, 60 miles east along the coast of Spanish Honduras. Truxillo is noted in history as being the first place on which Columbus set foot on the mainland of America. Truxillo and La Ceiba are the two largest towns on this part of the coast having a population of about 4,000 each, 95 per cent of which is Carib Indian, negro or half-breeds mixed with Spanish or English. The coast is bordered by a series of mountain ranges from 1,000 to 2,000 feet high which are densely covered with the forest

growth peculiar to that country. The small areas of low level land along the shore are covered with cocoanut palms or are being planted up with bananas by the American fruit companies, which are developing the country.

#### The Journey Inland.

At Truxillo I secured an interpreter, as the native language is Spanish. This interpreter was a negro, a native of British Honduras and very loyal to the British flag. I also secured a native to drive the pack mules. Leaving Truxillo we followed the old trail running from the coast, over the mountains inland to the capital, Tegucigalpa. This trail was built several hundred years ago by the Spaniards, all the grades being paved with large flat rocks. Three days along this trail took us about 70 miles inland to the vicinity of the timber to be examined. There we secured the services of four natives, a mahogany hunter, cook and two trail cutters. We did not carry tents, but built wide shelters out of the palm leaves which is the universal material for protection from the rain and rays of the sun.

### A Land of Laziness.

The natives of the country, that is the true Honduranian, is of Spanish descent. Those living in the forest and on the small farms are easily pleased from the point of view of comfort. Their houses are rude structures built of poles, with clay plastered walls, clay floor and thatched roof. The furniture consists of a rawhide drawn over a frame for a bed, a rough table and a couple of blocks of wood for seats. Sanitary conditions are very poor, the cow and pigs and chickens spending as much time in the house as the human portion of the family. Due to the ease of obtaining a living in that warm climate, the people are far from being industrious or thrifty, and live under conditions a northerner would not tolerate.

During the dry season, which lasts from April to October, the temperature at night is from 75 to 85 degrees. During the day from 85 to 95 degrees. In winter, November to March, the rainfall is excessive and the cool, damp winds cause the natives to succumb to cold and pneumonia, because they have no way to warm their



A good specimen of a mahogany in a dense Honduras forest—15 feet in diameter, at height of six feet.



With a Canadian party hunting mahogany in Spanish Honduras. Note the native dugout canoe.

houses, nor any warm clothes to put on. With the thermometer at 95 degrees in the shade it is certainly hot, although the heat is not oppressive and there seems to be little danger of sunstroke.

On the very sandy soil a few groves of pine were found, the wood of which was hard and full of pitch, closely resembling the southern shortleaf pine. All of the other trees are hardwoods (deciduous). About 30 species of these were common and I have seen places where 15 different species of trees could be counted while standing in one place. About the only trees similar to any trees in Canada were a species of oak and also one of locust. The oak, however, as a rule, grows short and scrubby, seldom being found on the high forest. Of the other species the leaves resembled those of the sycamore, beech, locust and walnut, while the woods were similar to that of ash, maple, beech and basswood, some hard and some soft. One species, the Granada, has wood which is very hard.



### A Variety of Trees.

The conditions peculiar to the forest in this region are first: The extreme density; second, numerous tree species; third, buttressed roots, hard and dark in color, somewhat like ebony. The greater number of the trees are from 2 to 4 feet in diameter breast high, and 90 to 125 feet high, and as a rule 60 feet clear of limbs, and with very little taper. The dense growth of palms from 20 to 50 feet high, the climbing leaves and the small plants growing all over the larger trees give the forest an aspect totally different from the northern forest.

### Wasting Mahogany.

At present there is no market for any of the woods except mahogany and Spanish (cigar box) cedar. On the area examined, consisting of 14,000 acres of actual mahogany land there were about 7,000 mahogany trees of commercial size and about 250 cedar. The trunk, especially the bark, is very much like the ordinary white elm. The crown while large is unlike the elm, rather irregularly branched. The tree grows to a diameter of about 6 and 8 feet; those above 7 feet being rare. In the dense high forest it frequently attains a height of 75 feet to the crown, but in the vicinity of the Savannahs is much shorter. The mahogany is always the tallest tree in the part of the forest where it is growing, always successfully overtopping all the other trees. The rate of growth on trees from 2 to 4 feet in diameter seemed to be from 4 to 6 rings to the inch.

The trees are felled with long-handled axes and cross-cut with saws. The logging is very wasteful on account of the logs having to be perfectly sound and with little curve or crook. Then besides the minimum sized log is 16 feet in diameter and 12 feet long, so the waste is enormous. The logs are hauled with oxen, six yoke of oxen hauling about a thousand feet board measure, or four or eight wheeled wagons.

In the river the logs, which float very low in the water, are handled loose or in rafts. London and New York are the largest markets.

Preston, Ont., July 24, 1919. L. C. TILT.

### MAKE THE GUILTY PAY!

(*Montreal Star.*)

When one considers how valuable lumber is to-day, the destruction of large forest areas by fire, which are now being reported, makes depressing reading. Canadian forests are valuable beyond computation, and their preservation is a matter of national concern.

It is to the credit of the Dominion and Provincial authorities that steps have been taken to preserve our forest lands, but very much yet remains to be done. There is abundant proof that a large percentage of forest fires can be traced to careless actions on the part of settlers, hunters and others. Those who gather around camp-fires and march away, leaving embers aglow, should be indicted for criminal carelessness. There is no excuse for such gross stupidity. Lives in addition to monetary loss are annually sacrificed to it.

### TERRIFIC FIRES IN UNITED STATES.

(*Press Dispatch*)

Racing over mountain ridges of Western Montana and Northern Idaho, forest fires which have been burning during July continued to spread destruction, and threatened several small towns which have been severed by flames from communication with the United States Forest Reserve headquarters at Missoula, Mont.

The fire near Henderson, Mont., jumped the mountains into the Mullan Gulch country, where there is said to be practically no opportunity to stop it. The fire near St. Regis, Mont., crossed the Clark's Fork river, and is spreading unchecked over a large area. Only with favorable weather conditions is there any possibility of controlling the flames, District Forest Service officials said.

It was reported that the sheep caught at Alberton between two cross-fires and destroyed numbered 1,700.

One of the worst fires in the district was said to be in the Salmon Forest, just across the Idaho line, south of Dillon. The fire is sweeping over the mountain on a six-mile front with the wind blowing a hurricane to fan the flames.

### THE CIGARETTE ONCE MORE.

(*Nelson, B.C., News.*)

A small bush fire was put out by D. Cameron and W. Billington on the Granite road. The blaze was thought to have been caused by a cigarette stub tossed away by a passerby. It only burned out a few yards of brush, but if it had not been noticed in time would have resulted in a serious fire, as it was close to the ranch homes on the road. It is pointed out that persons walking or riding on the country roads should be extremely careful about throwing away matches or stubs of cigarettes and cigars, as in this hot, dry weather the flames spread rapidly.

## "TREE WIRELESS"—A NEW APPLICATION

*By Douglas R. P. Coats, Montreal.*

### No More Elaborate Towers and Expensive Aerials Liable to Breakdown—Just Trees Themselves.

An article of great interest to me as a wireless man, but particularly so on account of my experiences as demonstrator of radio-telegraph equipment on the Canadian Forestry Association's exhibition car last year, appears in the "Electrical Experimenter" for July.

In this article, Major-General Squier, Chief Signal Officer, United States Army, describes some experiments in which he has used growing trees as radio "antennae" with remarkable success. The layman who has seen wireless stations or pictures of them will have noticed the high masts or towers and the elevated arrangement of wires which have become so associated in our minds with wireless stations as to make us think of their threatened existence—for science is declaring them unnecessary—with the same feelings of regret with which we note the disappearance of revered landmarks. Radio engineers, however, have been eyeing these picturesque structures with entirely different sensations, begrudging the cost of materials required in their construction and maintenance, but objecting particularly to their prominence where secrecy of location would be most desirable, for the average wireless mast simply will not be "camouflaged!"

In non-technical language, the prime function of the aerial is that of radiating energy from the transmitter into space in the form of aether waves, which, meeting aerial systems at receiving stations elsewhere, can be absorbed and converted into audible signals. Generally speaking, the waves emitted from a station are radiated fairly equally in all directions, though in many cases aerials are constructed with distinctly directional properties, that is to say, the bulk of their energy may be propagated so as to produce a much greater effect on a receiver situated at the point. It is obvious that if energy is radiated in all directions, the amount absorbed by any one receiver must be extremely small, and even where both transmitting and receiving aerials are designed to have strong directive properties one to the other, the waste of energy is still so enormous

as to necessitate elaborate aerial systems at each station and the use of very delicate receivers responsive to the feeblest currents.

#### **Amplifying Sound.**

Recent advances in receiving apparatus have now revolutionized radio communication to such an extent that we hear of signals quite inaudible with types of receiver used only a few years back being amplified several million times so as to produce sounds of such intensity as to permit the operator to place his head telephones on the table, walk a hundred feet or more away and still hear them! As a result of these improvements the transmission range of any given powered apparatus may be said to have been increased, though not in the strictest sense, for it is not so much that signals can be made to go farther today with a given input of power than hitherto, though this is also true, but rather that the sensitiveness of receiving instruments has been so increased as to permit of their being detected at greater distance.

With signals amplified as we are able to do today, we can get along minus any receiving aerial at all in many cases—unless a simple loop of wire suspended in the operating room may be called an aerial—with an arrangement of buried wires such as was invented by a Mr. Hughes in the States and used for communication with submarines, or with what may be found most suitable for wireless in Canada's forests—a "tree aerial" system as worked out by Major-General Squier.

#### **How a Tree is Used.**

In his article he says that radio messages have been received in America from England, France, Germany and Italy by connecting a wire attached to a nail driven into a tree! The nail is driven near the top of the tree, and the insulated wire is joined to a small piece of wire netting laid on the ground beneath the tree. "One of the best arrangements is found to be an elevated tree terminal in the upper part of the tree-top and an earth consisting

practically of several short pieces of insulated wire, sealed at the outer end, radiating from a common centre, and buried a few inches beneath the surface of the ground in the neighborhood of the tree."

In view of the work now being done by aeroplanes in patrolling certain forest districts, it is interesting to note that "Radio-telephonic messages from airplanes were readily received and transferred thence to the wire system . . . and finally received at any point desired," and also that "Radio-telephonic transmission through the tree antenna was received by another tree antenna and automatically returned to the sender on a wire system, thus making the complete circuit."

Of the marvellous achievements of the wireless telephone I hope to have the pleasure of writing in subsequent articles for the readers of this journal. It is unfortunate that the repeated publication in the newspapers of far-fetched radio "records" should have sickened a considerable section of the public till many of them have reached the point of taking truth and falsehood alike with a "grain of salt." This fact, coupled possibly with a growing inclination among men living in a wonderful age to accept things as they come, and to regard nothing new with half the astonishment which greeted the appearance of the first steamboat, may account for the little attention paid to the announcement of President Wilson's radio-telephone conversation from the "George Washington" in Brest harbor with Secretary Daniels in his office at the Capitol! The distance was about 3,000 miles, and the voice was carried by land wires to the coast and thence by the aether to the "George Washington"—truly a wonderful thing, if we men of the twentieth century will only think back twenty years or so and imagine what such an announcement would have meant then!

With a rapid and efficient means of communication by radio-telegraph or radio-phone between selected points in our forest regions and with patrolling aeroplanes, Canada's annual fire-waste will be tremendously reduced. With no wireless stations in the forests, enabling aeroplanes to report without coming down or dropping messages likely to go astray, the aviator observer is going to work under a great disadvantage.

There is little doubt in my mind that wireless will ultimately come into general use in the forest. No line wire system can offer the

same service as will be provided by Radio which permits communication with land, sea and air either by telegraphic signal or by transmission of the human voice. It will be interesting to see if further experiments with the "tree aerial" will lead to its adoption for forest wireless stations, and surely it will be strikingly appropriate if, for their own protection, we employ the trees themselves!

---

## A GREAT TESTIMONIAL TO PRAIRIE PLANTING.

---

Until this last two years I have always felt that while tree plantations about the buildings were most highly desirable, they also had their drawbacks. While there is nothing that protects the farm home like a grove of trees and gives it a homelike appearance, the trees take a lot of moisture and it is almost impossible to grow a garden close to trees or inside a small windbreak. Further, in the spring after a heavy snowfall the trees hold the snow and frequently keep the ground near them wet very late in the spring. A row of trees along the road sometimes makes the road impassable for weeks.

Last spring, however, and again this spring, I have come to put a higher value on the trees on my farm. I have a windbreak running south from the road for about 20 rods. It was planted ten years ago and is 14 to 20 feet high. A field just east of this windbreak was summer-fallowed and seeded to wheat in 1918. It ran south the full half-mile and was 60 rods wide. Over half this field at the south end was completely drifted out. Where the shelter belt protected the field from the west and northwest winds I never had a better crop and it checked the force of the wind right across the 60-acre field.

This year I noted the same effect on a neighbor's farm. On my own farm the field was spring plowed and none of it drifted badly. I have come to the conclusion that the policy of planting a system of windbreaks is the only permanent measure of controlling soil drifting. In planting, I would suggest that they be planted in rows half a mile apart running north and south. Nearly all the high winds that do the damage are almost directly due west winds. I realize that such a plan must be started on a small scale, but it would soon grow to be the greatest tree plantation ever undertaken.—G. H. Scott, in a letter in the *Farmer's Advocate*.

## WHAT IS CALLED FOR IN AN AEROPLANE

*(Timber Trades Journal.)*

To make aeroplane propellers "bone dry" they are subjected to terrific tests, and a propeller has to make 1,700 or more revolutions a minute to make good. Even at that, wood which has been dried to the lowest possible moisture content will "drip" sap after a test. Whereas for ordinary commercial uses a piece of wood showing a slight defect may be safely and advantageously used, there is no "margin of safety" with aeroplanes. Every bit of wood that enters into its make-up must be perfect. A thousand feet of lumber may have to be taken out of a forest to secure 50 feet or 100 feet which will measure up to aeroplane requirements, or the whole lot may sometimes be rejected. This shows the need of more tree plant-

ing, of proper forest conservation, and a national forest policy which will provide for the future. Walnut is the best wood that grows for propellers, as also for gunstocks, but practically all of the framework of the air machine is of spruce. Most of the parts of an aeroplane are of built-up or laminated wood in which thin layers are glued together, the lamination dividing the stresses and making possible the use of small pieces, which are more likely to be absolutely free of defects. The terrific pressure, the twistings and manoeuvres to which an aeroplane is subjected, compel the use of perfect wood that will "give" properly under prodigious strain without breaking.

## DROP "WOODLOT" AND USE "WOODLAND"

*(Bulletin of the Forest Service, U.S. Department of Agriculture.)*

The increased interest in the subject of private forestry, particularly with reference to farm forestry, has brought about the general acceptance of the term "woodland" or "woods" instead of the original one of "woodlot."

A large proportion of the woodlands in the eastern United States is in irregularly shaped tracts, spreading out over ridges, ravines, slopes, swamps, and poor lands, whereas "woodlot" carries the idea of a small-sized, regularly shaped, and, in a large section of the country, fenced tract. When applied to the large or irregularly shaped tracts, it is obvious that the word inadequately describes the conditions. "Woodlot" probably originated in New England and seems fairly well established there. So long as only conditions like those in New England were considered, "woodlot" was accepted as adequate, but in the last few years farm forestry has been developing rapidly throughout the country. The private forestry movement is of tremendous importance not only to the owner of woodland, but to the whole community in which he lives or in which the timber occurs. It is extremely desirable that the success of the movement should not be hindered by the use in forestry literature of a term which does not fit the conditions.

"Woodland" and "woods" are more satisfactory, more expansive, and avoid the possibility of creating confusion in the minds of the people over most sections of the country where the word "woodlot" has never been in local use.

### NEW HEAD N. B. FOREST SCHOOL.

Albert V. S. Pulling, B.Sc., in Forestry, of New York State College, who has been engaged in practical forestry work in New Hampshire, has been appointed Dean of the Forestry School of the University of Fredericton, N.B., and comes highly endorsed for the new post.

### "CRIMINAL DISSIPATION."

*(Montreal Star.)*

In the older countries the planting and care of forests is zealously carried out, the splendid monetary return being thoroughly understood. Canada's natural lumber wealth is practically the envy of the world, and the dissipation of this wealth is criminal. Public funds can be set aside for no better purpose than forest preservation.

# WHEN TREES GROW!—A NOVEL STUDY

By Prof. J. S. Illick, Chief, Department of Silviculture,  
Pennsylvania Department of Forestry.



## What Four Years' Daily Measurements of 200 Trees Disclosed—Common Conceptions Proved Erroneous.



Editor's Note: In Pennsylvania the northern and southern forests have a common meeting place. No doubt a study in Ontario or Quebec similar to that of Prof. Illick would alter the data in some degree, but at the same time the conclusions likely would not differ materially.

### PROF. ILLICK'S CONCLUSIONS:

*Trees grow almost twice as much at night as during the day.*

*White pine and Norway spruce cease growing (in Pennsylvania at least) by July 1st.*

*Such knowledge is of high utility in choosing the season for transplanting young trees.*

Nothing about the numerous processes of trees is more readily comprehended than that they grow, for the results of growth are so obvious, and in some cases striking, particularly in temperate regions where annually a period of

vegetative rest alternates with a period of vegetative activity. I propose to present for your consideration some interesting and essential facts pertaining to the growth behavior of our common forest trees: Growth, however, is such



Photo by J. S. Illick.

The new growth of Norway Spruce is flexible and drooping for a brief period immediately after the maximum height growth of the season has been laid on.



Photo by J. S. Illick.

Terminal twigs of Norway Spruce are erect and stiff at the end of the growing season.

a comprehensive subject, and some phases of it so technical that I have decided to limit myself to the question *When Trees Grow?*

### 200 Trees Measured Daily.

The data which will be presented herewith were collected near Mont Alto, Pennsylvania, by myself and by several of my former students under my direction during the past four forest tree growing seasons. The field work embraced the measuring of many trees at rather regular, usually weekly, intervals, and the keeping of meteorological records, especially of temperature and rainfall. In order to obtain detailed field data over 200 trees were measured daily during the 1918 forest tree growing season, and in a number of cases specific groups of trees were measured both in the morning and in the evening.

The belief is prevalent that trees grow throughout the general growing or vegetative seasons, which embraces in Pennsylvania from 150 to 200 days, and extends from the last killing frost in the spring, that is, when the leaves of the larches, birches, cherries, and maples appear, to the first killing frost in the autumn when the leaves exhibit their autumnal coloration. This, however, is a mere supposition, for most of the native and introduced forest trees in the vicinity of Mont Alto make 90 per cent of their height growth in less than 90 days.\*

The date when the different species start the elongation of their twigs depends upon the inherent tendency of the species and the factors of the environment. The late opening of the buds of Norway spruce is not a local characteristic, but an inherent tendency for records from Germany show that they usually open after May 8th, and in the extreme northern part the end of May. On the other hand, factors of the environment, such as latitude, altitude, exposure, shade and shelter, also have a strong influence on the starting time of the season's growth. As a rule, buds open about  $2\frac{1}{2}$  to 3 days later with each degree of latitude, and about 2 to  $2\frac{1}{2}$  days later with each 350 feet of altitude. White oak begins its growth from 7 to 14 days later on northern than on southern exposures on the Mont Alto State Forest. Trees with small and partially or completely imbedded buds such as Honey Locust, Black Locust, Kentucky

Coffee-Tree, Tree of Heaven, and Catalpa, begin growth relatively late. Nature seems to protect the tender growing points of these trees from the cold of winter by placing them within small buds which are almost completely imbedded within the twigs. This means of adaptation also protects the tender new growth of spring from late frosts, for the small and deeply imbedded buds are not stimulated so early in spring as large exposed buds; hence, the resultant vegetative growth usually appears after the damaging frost period.

### All Growth Ceases by August.

The range of the period during which the height growth of forest trees ceases is longer than that during which height growth starts in the spring. Most species of forest trees in southern Pennsylvania cease growing during the latter part of May and the early part of June. Only a few species continue their growth into July. On June 10, 1919, I examined 179 different species of trees in the vicinity of Mont Alto, 55 of which, that is 70 per cent, had already ceased growing in height. On June 18 and 19, 1919, I examined 50 species of trees in the vicinity of Bedford, Pennsylvania, and found that the height growth of 40 had already stopped. This is an unusually high percentage of growth cessation, and is probably due to the extremely cold period during the early part of extremely cold period during the early part of May, followed immediately by an unusually hot period during late May and early June. Such extreme temperatures and the abrupt transition from one extreme to the other are potent factors in retarding growth and in extreme cases may cause entire cessation of growth. The white pine, which usually stops growing in the vicinity of Mont Alto about June 15, but may continue to grow as late as June 30, ceased growing this year (1919) about June 3. It is the writer's belief that 85 per cent of the forest trees of Pennsylvania have already (June 20, 1919), completed their normal height growth for the season. Of the remaining 15 per cent the Tulip tree, Sycamore, and the Larches are prominent species, which may continue to grow until the middle or latter part of July. By the 1st of August the normal height growth of all the forest trees of Pennsylvania has, as a rule, ceased.

### Trees Rest Between Spurts.

In order to determine the progress of the height growth each species must be examined by itself, for each individual species possess dis-

\*Editor's Note. Prof. Illick's table of representative Pennsylvania trees, indicates that white pine starts its growth on April 18th, attains 92 per cent of growth on June 1, and ceases growth by July 1. Norway Spruce starts growth May 6th, achieves 74 per cent of development by June 1. Growth ceases approximately at the same time as with white pine.



HOW TREES OFTEN TAKE A HOLIDAY IN EARLY SUMMER AND LATER RESUME THEIR JOB OF GROWING.

The terminal twig grew 27 days, then rested for 23 days, and again resumed growth for about 25 days. The immature leaves indicate the portion of the twig which was developed during the second period of growth.

tinctive inherent growth characteristics. Some place their growth without a break, while others place it by leaps and bounds alternating with rest periods. In this respect the method of working followed by trees, and growth surely is work, differs little from the methods of other organisms, including man. Rarely does any organism work continuously, but rest periods are usually, and sometimes frequently, interspersed between the periods of work.

Few comprehensive statements can be made regarding the growth behavior of forest trees during the growing season. Yet, in spite of wide divergence the fundamental features of the growth procedure throughout the growing season may be summarized as follows: **Growth begins slowly, after a variable period rises rapidly, then reaches a maximum which is maintained for a short while, finally falls gradually to a minimum, and then ceases completely.**

The period during spring and summer when height growth does not progress may be regarded as a resting period, or a period of preparation. The trees apparently rest, but in reality they are preparing for the next upward thrust which may be longer than the original advance. Furthermore, the writer believes that the recurring rest periods may become a rather fixed and regular feature of the growth of certain

species. This is certainly true in the case of normal young Pitch Pine in the vicinity of Mont Alto, which exhibits annually a cessation of growth for a period of 2 to 3 weeks.

**Greater Growth by Night.**

The rate of tree growth not only fluctuates throughout the growing season, but also during each day. The maximum growth usually occurs late at night, apparently after the preparation and translocation of food and other essential materials becomes less active, and the minimum growth falls in the afternoon of each clear day when the greatest activity in the manufacture of starch and sugar is in operation.

About twenty trees of each of the four species given in the following tabulation were measured regularly at 7.30 p.m. and 7.30 a.m. for a specified period. The derived results for height growth during the day and at night are given in the following tabulation:

| Species.            | Day     | Night   |
|---------------------|---------|---------|
| Tree of Heaven----- | 35 p.c. | 65 p.c. |
| Tulip Tree -----    | 40 p.c. | 60 p.c. |
| Norway Spruce ----- | 18 p.c. | 82 p.c. |
| White Pine -----    | 39 p.c. | 61 p.c. |
| Average -----       | 33 p.c. | 67 p.c. |

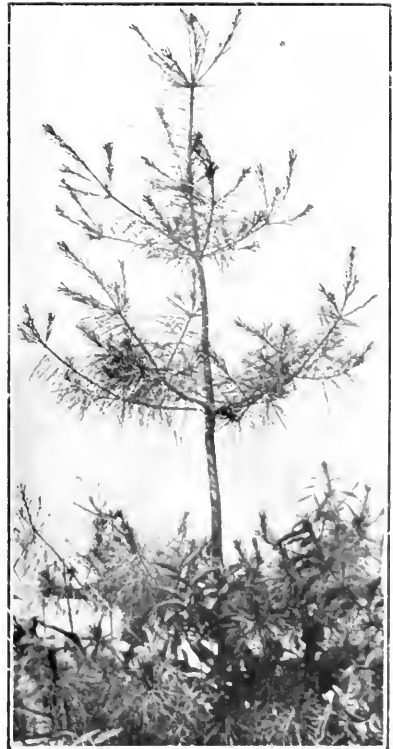

The foregoing tabulation shows that trees grow about twice as much at night as during the day. By using instruments of greater precision the percentages would no doubt be changed somewhat, but the general comparative rate of growth would still stand unchanged.

To some persons it may appear that the problem of growth behaviour of trees has only an academic application. This point of view is, however, untenable for there is an economic side to the study. If conducted in a scientific manner it will supply the basic data for the preparation of a rational schedule for transplanting in the nursery and setting out trees in the wood-lot and forest. Foresters, sylviculturists, and plant physiologists recommend that planting and transplanting operations should be conducted when the material to be planted is in a dormant condition. No fault can be found with their recommendation, but in order to execute it properly one must know when trees really are dormant. This can be ascertained best by determining when trees grow, since growth is so evident and measurable, and whenever trees are not growing they are dormant, that is, in a static condition, the duration of which is hard to determine.

Furthermore, such a study facilitates the preparation of a schedule for field work covering the problem of growth. That determination of the quantitative and qualitative growth on cut-over lands is one of the most important and urgent problems in American forestry is conceded by the most authoritative foresters. Heretofore, we have generally been instructed that the height growth of the season cannot be accurately ascertained until late in fall or during the winter months when the weather is relatively

unfavorable for field work and the days rather short. Consequently, it now follows that since trees actually cease growing in height in May or June, no reasonable exceptions can henceforth be filed against the collection of height growth data immediately after the cessation of growth in summer.

It should be understood, however, that the problem *When Trees Grow* is but a prelude to the major problem, which is far more comprehensive, and includes also a study of diameter and volume growth of the stem and the growth of roots, all of which should be undertaken; for the results derived therefrom would be of great economic value.

A knowledge of *When Trees Grow* also aids in the determination of the best time to peel bark. Bark can be peeled satisfactorily only when the sap is abundant and active. Briefly, the bark peeling season coincides with the growing season of trees.

#### Light on Annual Rings.

A thorough study of the growth of trees will also furnish much-needed information to the legal profession. Many legal decisions concerning boundaries and titles hinge on the question whether each growth ring represents the growth of one season, or if fictitious rings are sometimes formed. The writer examined a large number of Pitch Pine and Chestnut Oak trees and found that fictitious rings are regularly formed when a prolonged resting period occurs within the growing season. Hence, in some cases two rings represent the growth of a season, instead of one annual ring.

I wish to add that the problem, *When Trees Grow*, is not only of technical interest and economic value, but might be used as a means of developing real tree appreciation among the children of our public schools.

## PLANNING FOR FOREST REPRODUCTION

Dr. C. D. Howe visited the provincial forest survey parties on the head waters of the Miramichi, about 40 miles north of Boiestown, New Brunswick. The limits in this vicinity are mainly held by the Miramichi Lumber Company. Arrangements were made whereby a special party of four men will carry on the regeneration work and annual growth study the entire season directly under Dr. Howe's supervision. Dr. Howe spent about ten days with this field party. The balance of the time was spent in visiting the limits of the Bathurst Lumber Company and the Pejepsco Lumber Com-

pany, in order to study the condition of their lands which have been cut three times. Also slow-growing lands were examined, and it is possible that through the co-operation of the Bathurst Lumber Company and the New Brunswick Government an experimental plot of 600 acres may be established and receive special treatment in the method of cutting. This will come directly under Dr. Howe's supervision, through the New Brunswick Forest Service. If this plot is established it will be one of the largest in Eastern Canada.



# HATCHING TREES BY THE MILLION

By *Gustave C. Piché, Chief of Forestry Service, Quebec.*



Splendid Results at Berthierville of Quebec's Forward Policy in Reforestation—Trees for Highways Too.



The nursery of Berthierville was established in 1908 by Hon. Mr. Turgeon, then Minister of Lands and Forests, in view of furnishing planting material to the private owners of waste lands and also to enable the government to make practical demonstrations in reforestation. It was the first provincial nursery, it is the only one yet devoted entirely to this purpose. At the origin, it was a farm of 70 arpents which had been abandoned for many years with the result that the buildings and the land were in a very bad order; even the woodlot exhibited evident signs of mismanagement. The first years were devoted towards re-establishing order throughout the property and to raise on a small scale forest tree seedlings.

On the 22nd of May, 1908, the first sowings were done, and in the autumn we found that the nursery contained a little over 200,000 plants of which the white pine, the Scotch pine, the Norway spruce, and the European larch formed the bulk. I must say that, at first, the neighboring farmers were very skeptical about the success of our enterprise, but many of them began during the second year to admit that there was something in the idea which the Government had endeavored to propagate in the province and very soon the nursery was, and is still, the favorite spot where they bring their visitors to see the great curiosity.

To give my forestry students a practical knowledge in reforestation, it was arranged that they would work two months each spring at the nursery. We must congratulate each class of the Laval Forest School for the good qualities that they have displayed during their stay here; indeed, it was very hard for these college boys to be put on the spade, to harrow or to weed under the burning sun, but they accepted their instructions cheerfully and worked ten hours per day, just as ordinary laborers, faithfully and with great interest. I must, in justice, at-



G. C. Piché, Chief Forester of Quebec.

tribute to them a good deal of the success that we have obtained so far.

## A Helpful Minister.

It would have been impossible to carry on our programme which meant to increase the production more and more every year, in order to cope with the increasing demand for trees if we had not obtained the continuous support and the encouragement of the present Minister of Lands and Forests, the Hon. Jules Allard, who, as you know, has helped so much to the development of a sound forest policy in this province. It was he who obtained for us each year the necessary credits from the government and with the sinews of war we were able to increase every year the area under cultivation.

In 1910 some of the seedlings were big enough to be shipped, and we started the re-

clamation of the shifting sands in the parish of Lachute. These shifting sands, as you are no doubt aware, are the result of poor methods of cultivation that have exhausted some of the farm lands in that section; gradually the grass cover began to disappear and the sand to show up; very soon the wind caused the displacement of its particles; every year things went from bad to worse, till finally there was a dune of about  $3\frac{1}{2}$  miles in length, broadening in its middle to about one half-mile. The sand not only prevented any cultivation upon the area affected, but also invaded with persistence the adjoining farms so that the area of waste land was increasing gradually. The government of the province passed an agreement with seven owners to buy their land at \$1.00 per acre in order to reforest same, giving them the option to buy it back after 15 years for \$10 an acre. We began our work by planting on the western edge of the sand dune some 20,000 pines and spruces, with a few elms and ash; these broad-leaf trees were used exclusively for experimental purposes. The next year 50,000 more pines were set in to replace part of the trees that had died (about 20 per cent) and also to increase the surface planted which is now equal to 45 acres. To-day these trees have not only maintained their hold on the pure sand, but have grown up to five feet in average; many are ten feet in height; the sand has been stopped from shifting and a grassy vegetation is exhibiting itself here and there. Beech grass was also used. The result is so satisfactory that the former owner of the land has assured us that he would buy back the land at the expiration of the contract. Similar work has been done at Berthier Junction in recent years.

The same year we began shipments of trees in various lots to private individuals, colleges, etc., and we have continued this ever since.

#### **On the Perthuis Seignory.**

In 1911, the Seigneur of Perthuis ordered fifty thousand pine and spruce trees to be set near Notre-Dame-des-Anges, and every year since he has repeated his order for about the same quantity. I have just received a report of these plantations and the white pine trees thereon show a growth of 4 to  $5\frac{1}{2}$  feet in height, whereas the spruce range from 2 to  $2\frac{1}{2}$  feet in height. According to those who have seen the plantations they are a real success and a good example to follow.

At the present time the stock of trees in the nursery exceeds four million plants; and we are preparing ourselves to be in a position to ship

every year from two to three million plants as we believe the demands will not only reach this amount but will most likely exceed it before long.

As a consequence of the initiative of the government some limit-holders have also established forest nurseries and we hope the every large forest operator will do the same thing.

With a few exceptions all the seeds used at the nursery have been purchased either in America or in Europe, but we would like very much to be able to use the indigenous seeds as they offer greater chances of success.

We would like to obtain each year from the various parts of the province a sufficient supply of the seeds of our white and red pine, of our spruce, hemlock, cedar, white and yellow birch. We will obtain not only better seed but also cheaper seed. It is our ambition to produce at this nursery all the seeds needed not only for our work but also for the other nurseries in the province and to meet this purpose we intend to build in the near future a large seed house where we will extract the seeds collected after the most modern methods.

#### **Aim at 10 Million Seedlings.**

Having attained this object, we could then realize our second aim which is to produce to not only two or three million plants per year but ten to twenty million plants, if needed, in the province, and I think that before long we may be planting more than that. This intensive production of plants would greatly diminish their cost and I calculate that, if we could produce here ten million plants per year we would be in a position to sell them after caring for them for two years, for \$1.50 per thousand, whereas we are now asking from three to five dollars per thousand for the same material. These young plants could be transplanted in the various nurseries that would be established in the neighborhood of the lands to be reforested so that they would be acclimatized before the final setting.

During your visit at the nursery you will see many trees of foreign origin; for example, you will come across the Scotch pine which will appear to you as a sturdy tree, in fact it gives us great hopes for the reforestation of our waste lands. The Norway spruce, though not always as good as our native white spruce, will also give excellent results as it grows fairly well. The European and the Japanese larches will certainly interest you as they appear to be more immune from the attacks of the saw-fly that annihilated our tamarack some thirty years

ago. These foreign trees have been tried and we can recommend them to the planter. We have extended this research to most of the forest trees growing under the same climatic conditions of this province as we have studied also the bull pine of the Rockies; the black pine of Austria which is excellent for the plantation of limy soil; the Engelmann spruce and the Blue spruce of Colorado have been found to be of more value for ornamental purposes than for reforestation; the Douglas fir does not appear yet to be acclimatized enough to our conditions to justify its plantation extensively; yet we have found it to be hardy in some cases, and should this experiment come to a good conclusion I think the nursery will have achieved very much as it is a first-class tree.

### Shade Tree Supplies.

We have also endeavored to produce trees for ornamental purposes. As you are aware the building of the national highways in the province will necessitate a vast amount of

planting and we expect to have soon some ten thousand trees to devote, per year, to this purpose.

Everywhere people desire more and more to beautify the surroundings of their property by the plantation of hedges and of trees, and many farmers have called upon us to secure a few trees which we have gladly given them.

The railway companies have also been on the market, and we have sold to the Canadian Pacific Railway, the Temiskaming and Northern Ontario Railway, the Canadian Northern Railway, many thousands of trees for the beautifying of the stations, the holding of the railway banks, etc., etc.

Our arboretum which has an area of some five acres, is located between the nursery and the woodlot. It may be interesting to you to learn that ten years ago this land was pastured and covered only with a meagre grass. By preventing the grazing we have allowed the forest to re-establish itself solidly on the eastern half, and you will find there some grey birch

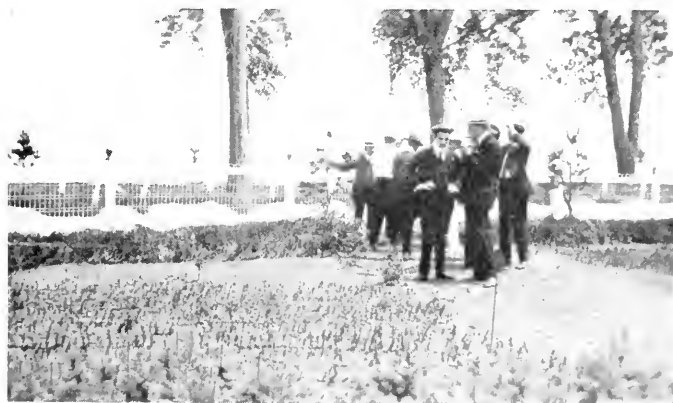

At the Berthierville, P.Q.,  
Forest Nursery.

Studying some interesting  
instances of Spruce growth.





—"by the side of the road,  
And be a friend to Man."

An advertisement, maybe, but a welcome one. Mr. Jaime of Kitchener, Ont., prepared this drinking spot over a woodland spring.

of about twenty feet in height with a diameter of three inches. Here and there we have made plantations of several foreign trees in order to study their development under these conditions.

### A Model Woodland.

Coming to the woodlot, you will find a good example of what could be done similarly by each farmer in this province. Its area is close to twenty-five acres; it rests on a soil formed by a coarse sand of the poorest quality, yet you will find the trees to be in good health, tall, and of a fair size. The composition of the stand is also interesting as almost each specimen growing in the province is represented. In the first half we have aimed to develop a mixture of maple and white pine, favoring however the production of white pine. The other half is devoted to the best trees as they appear.

This woodlot was divided into eight compartments of equal size, and contains some

5,400 trees with a total volume of over 500,000 feet board measure. Two excellent roads made by the students divide the property equally. Each tree measuring four inches and up was calipered and numbered last year, and record is also kept of its health conditions. We expect to continue these measurements every two or three years so as to judge of the progress and increases in its growth. Each tree that is removed during the year for silvicultural purposes is calipered and scaled, so that we will prepare eventually a volume table for this section of the country.

Already one-quarter of the forest has been culled under a rigid system of silviculture and you will see that the forest does not appear to be in a bad state though the cutting of one compartment yielded seventy-two cords of firewood and two thousand five hundred feet of sawlogs; the whole being valued at eighty-four dollars. These operations will not only increase the value of the stand by the selection made of the best species and of the best trees, but the growth will also be increased and stimulated by the treatment.

### WHOLESALE LAND CLEARING.

(*Edmonton Bulletin*)

Experiments in clearing land in the Peace River country of poplar, green willow scrub and dead timber have been made recently by a party which returned from the north. The method which it was desired to test was that suggested by Hon. J. L. Cote, member for the Grouard district, a number of years ago, namely burning it during the early spring while the ground is still damp. Their tests proved that it can be done without injury to the soil.

Normally when a fire sweeps across country the soil is burnt out to a depth of several inches. The experimenters discovered that in the early spring, when the grass is starting and the leaves budding, by firing the scrub along the top it will burn down the slope to the low damp ground where it goes out owing to the moisture. If done at this time of year the soil is not injured and moreover fire guards are created which are protection later on. There are hundreds of thousands of acres of rich land in the Peace River country that might be cleared by spring firing which, unless cleared, will lie uncultivated for many years.



How the Quebec Forestry Service is stabilizing shifting sands by planting trees at Berthier Junction. Forty-five thousand trees were planted with a 15 per cent loss.

## TORONTO'S WOODLAND SCHOOL FOR CHILDREN

One of Toronto's interesting educational experiments is the Woodlands School in Victoria and High Parks where desks are placed beneath the trees and the little folks take two hours sleep every afternoon. It is operated by the Board of Education and Board of Health in combination.

Sharp at 9 o'clock each morning a cup of cocoa or milk is served to each child, and then lessons begin. On fine days the studying is all done in the open-air school-rooms, blackboards and benches being arranged in three different parts of the grounds. At 10.15 another cup of milk is served, and the children are allowed to play for twenty or twenty-five minutes, then follow lessons once more, until nearly 11.30, when preparations are made for the mid-day meal.

At the long zinc trough to the rear of the pavilion, the children go through their "wash drill," from which they emerge clean and sweet, and ready for dinner. This repast is served in the dining-room, at six long tables, the food

being prepared in the conveniently-equipped kitchen. On rainy days the dining-room serves also as a class-room.

At 1 o'clock the children betake themselves to their beds, under the tall trees, and at least ninety per cent of them sleep soundly each day for two whole hours. At 3 they are wakened, rise promptly and make their own beds, and then are treated as a usual thing to the ever-popular story. After that there is time for a little play, and just before they leave for home, at 4.30, every boy and girl has another glass of milk.

Each day from 10 in the morning until 2 in the afternoon, a nurse is present, and looks well after the health of the children, and once a week all are weighed. Special care is taken to train the pupils in the care of their teeth, and always after dinner there takes place what is known as the "tooth-brush drill." On fine days, too, when the water is warm, there is swimming in the lake.

## JACK MINER'S SCRIPTURAL FLIERS

---

Readers of the Forestry Journal are well acquainted with the wonderful work of Jack Miner, of Kingsville, Ont., in constructing a bird sanctuary and studying the migrating habits of ducks and wild geese, season after season. Here is a new feature of Mr. Miner's unique story, dealing with his custom of attaching tags to the legs of birds before they start on their journey to the north or south:

### The Story of the Tags.

Nothing more clearly exemplifies the originality of Jack Miner than the story of the tags. Since 1911 he has set his mark on 287 wild ducks, and over 100 tags belonging to them are now in his possession. He has also had returned 34 goose tags. These are little strips of aluminum. Upon one side of each is printed, "Return to Box 48, Kingsville, Ont.," and on the other outlined in large, clear characters, is a verse of Scripture.

"I believe I am the first man on earth to use the bird as a missionary messenger," said Mr. Miner. "The idea came to me one day, and I acted upon it. It can't do any harm, and it may do good."

Here he produced a letter from a man in Illinois, who shot down a bird whose tag bore the message, "He careth for you." "While this really belongs to you, I would like to keep it on account of the message it brought me," read the letter. Needless to say, the writer was granted his wish.

A still more impressive story had to do with a colony of negroes in the State of Louisiana. It happened that several negroes on a plantation went to hunt for wild geese. Into the hands

of a negro preacher there fell a grey goose bearing a tag. To the superstitious mind of the negro the verse of Scripture it bore was as a voice from heaven, and in a state of great excitement he returned to his people and forthwith there began one of the greatest revivals ever known in that part of the country. The truth of this tale is vouched for by a lady who was visiting in the vicinity when the evangelistic fervor was at its height. She afterwards heard Mr. Miner lecture, and gave him the story in writing.

### A Home for Bob White.

The quail, Mr. Miner declares, is the most valuable of all Canadian birds, and is well deserving of protection. Owing to the fact that it does not migrate care must be taken to carry in through the severe winters. In January, 1918, a terrific three-day storm almost exterminate this bird in the neighborhood of Kingsville, but the very mild winter of a year ago was favorable to the few survivors, and they are increasing very rapidly. Delightful winter quarters are being made ready for the quails in the sanctuary. Hundreds of Scotch pines have been set out by Mr. Miner during the past five years. These mature quickly, and when larger grown will form a close covering for their winter residents, so that no storm will ever harm them again. Plans are also under way for the building of food racks. And just here let me say that Mr. Miner advises the planting of wild grapes, elderberry bushes, mulberry trees and any other shrubs that bear fruit, so that birds, once in safe quarters, may not find a scarcity of food.

---

## FOREST FIRE ITEMS OF THE MONTH

---

The United States Government has been spending \$15,000 a day to fight forest fires in Montana and Idaho.

A sawmill owner near Fort William, Ontario, was forced to take to a small boat with his wife and family to escape forest fires that destroyed his \$25,000 mill. The party spent the entire night in the middle of a lake.

Camp fires started by fishermen in the Elbow River districts of Alberta have caused serious timber losses this year. One of the worst timber fires in Alberta's history was started by a fisherman in 1910. He was fined a ten dollar bill "and severely reprimanded."

## *Tree Planting on the Prairies.*



Here is seen the beautifying effect of tree planting and gardening about the residence of Mr. Norman M. Ross, at Indian Head, Saskatchewan. There is no reason why the majority of homes on the "bald prairie" should not be transformed in a similar manner.



The home of Mr. Ross at Indian Head before tree planting was commenced. The place is hardly recognizable when compared with the top picture and yet the difference is entirely represented by trees and shrubs. The secret of "Home, Sweet Home" is a tree planting programme.

## *How a Tree Plantation is Started.*



Girls removing young seedlings from the Laurentide Company seed beds at Proulx nursery preparatory to "heeling in" for transplanting. Mr. Ford is foreman in charge of the work.



How the seedlings are "threaded" into the planting board. Note the empty board leaning against the corner of the cabin. Portable cabins are employed in this work.

Incidentally, Girls have been found to be much more dexterous workers than boys.



Transplanting the seedlings to the open field. The girl holds the planting board while the men pack the earth against the roots of the seedlings. "Planting boards" are great labor savers and do more accurate work.





Here we see the baby trees set out in their final site at Proudly, near Grand Mere, P.Q. The casualties are very light, even at this tender stage. Eventually the waste land will bear a heavy crop of spruce trees to feed the ever-famishing grinders of the pulp mill.

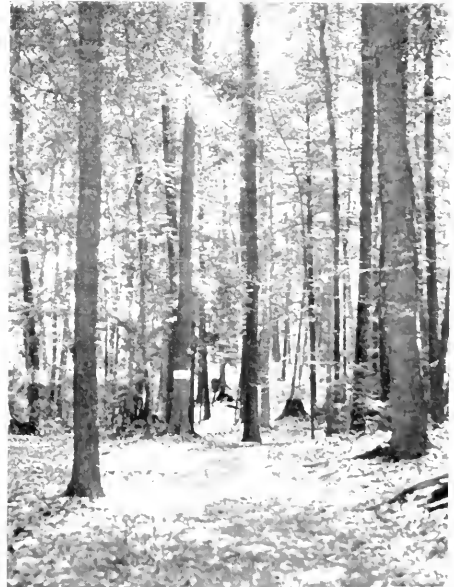

Photos by courtesy of J. C. Jaimet, Kitchener, Ont.

Waterloo County's conservation spirit is here exemplified. Photographs show typical scenes of Cressman's woods, which are a continual source of delight to thousands of people every summer. Many of the trees are 100 to 150 feet high.



Photo by kindness of J. D. Irving, Ltd.

NEW BRUNSWICK AND FOREIGN TRADE.

The upper waterfront at Buctouche, N.B., showing vessels loading lumber and other products.



On the Athabasca River.



Lower Kananaskis Falls, Bow River.



Kananaskis Falls, Bow River.



On the Nelson River.



Four million feet of logs in the drive of J. D. Irving, Ltd., Buctouche, N.B. Logs are the life-blood of New Brunswick's greatest industry and forest conservation is the secret of a continuous log supply.

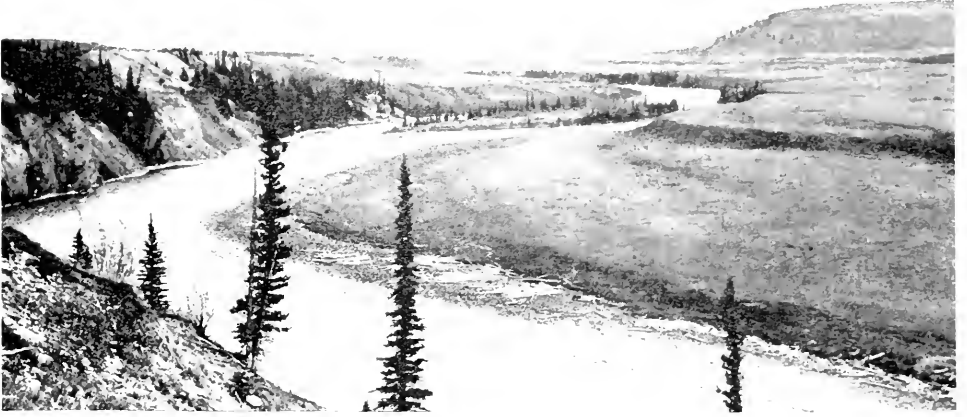

Bow River.



Athabasca River. Grand Rapids from below.



A STRIKING VIEW OF BOW LAKE.



GRAND RAPIDS, SASKATCHEWAN RIVER

## QUEBEC SUFFERS SOME FIRE DAMAGE

Quebec, July 16, 1919.

We have had a good deal of trouble in regard to forest fires as the extreme drought that prevailed during the whole month of June has caused such a serious situation that the reports of fire are coming in from every direction. Besides several settlers took great risks in lighting, without permit, their clearances, so that the staffs of the associations and of the Forest Service had a hard time to control the situation.

On the south shore of the St. Lawrence, there were practically no bad fires though outbreaks were frequent, but the good organization checked them rapidly.

In the Ottawa district the fires have not caused any great damage.

On the St. Maurice two bad fires were caused by the railway at Vandry and Timbress, causing

the loss of a large tract of forest. There are provincial officers on the ground to investigate the damage done.

In the Lake St. John district great fires occurred at the head waters of Riviere-aux-Ecorces, Riviere Chicoutimi and Riviere-a-Mars. There the difficulty of bringing men allowed the fire to extend rapidly, but most of it ran through cut-over lands, reducing the damage to some extent. Here again there is no positive data for the present.

In the Abitibi, there were at least 30,000 acres of slash to be burnt and the situation was grave; fortunately the rangers succeeded in holding the fires in check and in saving the properties and lives from the threatening danger.

From the information gathered, the damages ought to prove small. Yet there will be a few miles of green forest destroyed.

## MEMORIAL TREES

*By Dr. Frank Crane.*

They are threatening to put up Memorial Arches. A Memorial Arch or statue or some other such ornament doubtless can be made very pretty, although most of such things that I have seen in cities are about as useful and as comforting as the parlor clocks they have in the hotels all over Europe, clocks that never run and are not very valuable toward elevating the soul.

Patriotism is beautiful, and the sentiment is beautiful which wishes to commemorate in some abiding way the heroism of the men who went to die in France. But why must all sentiment run in ruts of convention?

They have been building monuments, tombs, mausoleums, from the days of the pyramids. Man is a tomb builder. How much better it would be if we could get away from this idea entirely and put up Memorials for the dead that should keep their memory green in the much surer way, by ministering unto the living.

I have already written upon the project of erecting community buildings to be dedicated to our heroes, and this plan, I am glad to note is being adopted in many towns.

Another idea has been advanced which is equally sensible and beautiful. It is to plant memorial trees.

In one city they are planning an "Avenue of the Allies," to be lined with trees in honor of the allied nations. The Lincoln Highway Association is considering the proposal to plant memorial trees along portions of its transcontinental route. In Louisiana memorial trees are to be planted, one every forty feet, along the Jefferson Highway. This is the road that leads to Winnipeg, and the slogan is "from pine to palm."

### AN ECHO OF THE WAR.

The managing editors of *La Papeterie*, the office of which is in Paris, announce the re-appearance, after an interval of fifty-eight months, of that publication. "We would have resumed publication earlier," they add, sadly and significantly, "but all the cuts, type and stocks of paper which were at Chauny have been stolen by the Germans and the printing office sacked."

## FUTURE FACTS THAT THE PRESENT MUST FACE

By Hon. E. A. Smith, Minister of Lands and Mines, New Brunswick.

On one section of our best growing Crown lands, Dr. C. D. Howe reports as follows on the average of a number of sample acres studied:

"This land was cut 25 years ago, and 37 spruce trees 12 to 20 inches in diameter were removed per acre. It was again cut 10 years ago, and 19 spruce trees 10 to 12 inches in diameter removed." This means that approximately 56 trees or about five thousand board feet was removed from this land during the last twenty-five years.

"There is now standing on this a total of 149 trees, 58 spruce trees per acre and 91 fir trees, over one inch in diameter. Of these growing trees 7 spruce and 8 fir trees are now of commercial size and if cut now would still leave 11 spruce and 10 fir trees, which would reach commercial size during the next thirty years. That is, there are 36 trees to provide the cut for the next 30 years." Dr. Howe states that if all our cut-over lands gave as good a showing and this, there would be little cause for worry, but the following counts made in another part of the province will give many of us cause for thought.

This locality was cut over three times, 30 years ago, 16 years ago and 4 years ago, and 97 spruce and 15 fir trees removed per acre averaging 8 to 18 inches in diameter on the stump. This means that 112 trees or probably between 9 and 10 thousand board feet or more was cut from this area during the last 30 years.

The trees still standing on the area show an average of 108 spruce and 186 fir per acre over one inch in diameter, but there are only nine of these trees large enough now to reach commercial size during the next 30 years. Dr. Howe says: "That this has been a very productive area, as the 112 trees removed per acre shows, but it has been quite evidently abused, as there are only 4 spruce trees that can reach commercial size in the next 30 years."

Plainly stated, this average acre from which at least 9,000 feet was removed during the last 30 years cannot produce more than 1,000 feet of commercial sized lumber during the next 30 years.

Of course these averages were secured over small areas, but they serve to indicate the need

of thorough study of this problem of annual growth.

### Maintaining a Great Asset.

Dr. Howe is one of the most widely known and experienced foresters in Canada and I have been able to arrange with the Conservation Commission to allow Dr. Howe to continue his study of the cut-over lands in New Brunswick. This particular branch of the Forest Survey will be given special attention during 1919, and I expect that Dr. Howe will be able to give us fairly definite estimates of our annual growth and also suggestions as to what changes are necessary in our logging regulations in order to maintain our greatest asset, the forest, in its fullest producing capacity.

The greatly depleted forests of France and England, together with the enormous requirements of lumber to rebuild the devastated portions of France and Belgium must open a greater market for our Canadian woods, and while we must take full advantage of this demand, we must be very careful not to ruin the potential value of our forests, but to conserve the greatest natural resources of our land, and in turn hand down to posterity, unexhausted, the great heritage so freely bestowed by nature.

### MY GARDEN.

A garden is a lovesome thing, God wot!

Rose plot,

Fringed pool,

Ferned grot—

The veriest school of peace! And yet the fool

Contentends that God is not—

Not God! In garden! When the eve is cool!

Nay, but I have a sign!

'Tis very sure God walks in mine.

—Thomas Edward Brown.

### OUR SEED FOR BRITISH PLANTING.

Canadian tree seed is being supplied to British woodland planters in a steady stream. The Dominion Forestry Branch at the request of British authorities sent over 125 pounds of miscellaneous seed in 1917, 450 pounds of Douglas Fir seed last year, and will duplicate that amount both in Douglas Fir and Sitka Spruce seed this year.



## EVERYONE SHOULD BE A BIRD MAN.

"Do you know that if all our birds were destroyed, in three years this continent would be without life? The insects would first eat all vegetable life and then eat us." said Charles P. Shoffner in a public address delivered recently. "Do you know that insects cause a loss of more than \$1,200,000,000 every year to the farmers, truck-raisers, and fruit-growers of the United States? Whatever affects the producers affects every consumer on the country. You know what will happen if this keeps up much longer: We will all have to go to work. Do you know that the farmers of the east pay more than \$15,000,000 a year for materials to kill the potato bugs? Who pays that? We do—and it is getting so I lift my hat every time I see a potato. Do you know that the cotton boll-weevil causes a yearly loss to the Texas cotton-growers of \$50,000,000? Do you know that the apple-producing States pay more than \$2,000,000 a year for spraying trees to keep down the San Jose scale-louse and the codling moth? Do you know that many species of caterpillars eat twice their weight in leaves daily? Do you know that certain flesh-eating larva consumes in twenty-four hours 200 times its original weight? Have you an idea of the reproducing capacity of insects? Do you know that the offspring of one pair of potato bugs, if allowed to increase without molestation, would in one year number more than 600,000,000? Do you know that one pair of the hop-vine aphid is capable of producing through the thirteen generations of the species in one year ten sextillions of individuals? Do you know that the unrestricted increase of one pair of the gipsy-moths would in eight years devour all the foliage in the United States? Talk of your Rooseveltian families! If ever birth-control is needed, here is a real honest-to-goodness job.

"I do not know why insects were created, but I do know why the birds were created. It was to keep in check the insects, the pests, and they can do it. In our brilliant career as Americans, and with a strong hold on the thought that the Lord will provide, we have killed just about 90 per cent of our birds. Is it any wonder that the ten per cent can not keep down the pests? Insects have appetites, but let me tell you about the birds:

"A quail taken in Texas had 127 cotton boll-weevils in its craw. Another taken in Pennsylvania had 101 potato bugs.

"A tree-swallow's stomach contained forty entire chinch-bugs. Two stomachs of pine-siskins contained 1,900 black olive-scales and 300 plant-lice. A night-hawk had eaten 340 grasshoppers, fifty-two bugs, three beetles, and two wasps."

### A "LEAVE-IT-TO-GEORGE" SPIRIT.

(Correspondence in *Toronto Globe*.)

"I was reminded in this incident a fortnight ago in the brief time that my train was changing engines at Schreiber. Immediately east of the village is a mountain the sides and top of which are covered with vegetation. A little way up the side, and in easy reach, fire, that had probably been started by a careless smoker, was just getting under way. Half an hour's work by a dozen idlers about the station would have extinguished the fire. But no one paid any attention to it, and had the dry weather then prevailing continued, the whole mountain side would have been changed from beautiful green to a blackened waste. Indeed the fire might easily have spread much farther, with the result of destroying young timber growth for miles around. Fortunately, nature was kinder than man and a couple of heavy rains in the following week put out the blaze and the only trace left is a brown blotch on a mat of green."

### QUEBEC'S FOREST OUTLAY.

The Legislature of Quebec has appropriated \$100,000 for the provincial forest service and the inspection of lands for the fiscal year ending June 30, 1920; also \$7,000 for the maintenance of the provincial forest nursery at Berthierville. The amounts are very materially supplemented by the expenditures on forest fire protection incurred by the Ottawa River, St. Maurice, Laurentian and Southern St. Lawrence Forest Protective Associations, which patrol the great bulk of the licensed and privately owned timber lands in the province. The expenditures of these four associations on fire protection during the past year total \$177,729.

The Motion Picture Bureau of Ontario has released through Regal Films, Limited, three copies of "The Story of Paper," featuring the manufacture of newsprint from the forests of Northern Ontario.

## TESTS PROVE FOREST'S EFFECT ON STREAMS

Experience has proved that the forest works efficaciously against many dangers resulting from the elements let loose such as avalanches, falls of stones, erosion, earthslides, inundations. These are facts admitted and indisputable, but how and in what measure does the forest exercise this moderating action upon the destructive power of water? How can it lessen the destruction from inundations?

It is in order to attempt an answer to this leading question that the Swiss Federal Station of Forest Research in 1900 installed an observing station in the basin from which two streams of the Bernese Emmental are fed. These streams tributaries of the Hornbach, are located in the territory of the commune of Sumiswald-Wasen, on the northwest slope of the Napf. The Geological formation is fissured pudding-stone which decomposes readily. One of the basins, with an extent of 140 acres, is completely wooded. The other with an area of 175 acres has only a small average of wooded district about 30 per cent. The forest is composed of spruce and of alder bushes. The measurement of the precipitation, rain and snow, takes place regularly throughout the year. In each of the basins there have been installed three rain gauge stations at different altitudes. At the junction

of the two streams with the Hornbach certain apparatus registers automatically every five minutes, day and night, the volume of the water flowing.

The research station is going to publish very soon the results thus obtained from these valuable observations. In the meantime if we refer to the provisional statements of the research station the two following points seems to have been definitely established:

1. In case of storms accompanied with heavy rains the maximum outflow in the wooded valley is from 30 to 50 per cent less than that from the other valley, and there is another beneficial circumstance from the action of the forest, that this maximum flow is produced later in the wooded basin than in the other.

2. In the long periods of drought (the summers of 1904, 1908 and 1911) the wooded district gave without interruption a flow of water while in the denuded valley the stream dried up and all the springs ceased although at a normal time they have an abundant flow.

These observations seem thus to have demonstrated irrefutably the moderative action of the forest upon the regulation of the stream flow which some have denied.

## PLEA FOR THE NORTHERN ONTARIO HOMESTEAD

Geological Survey,  
Ottawa, July 25, 1919.

Editor, Forestry Journal.—I have just returned from the newly opened territory in Northern Ontario, where farms are in the earliest stages of the making. What most forcibly strikes one there is the unnecessary desolateness and discouraging ugliness of the majority of these beginnings at homesteads. It is enough to take the heart out of any prospective settler before he has well begun, let alone those immigrants from towns, cities and the garden-like areas of older settlements.

The first thing that seems to be done is to burn off everything clean, and then set the site of the future home in the middle of the burnt waste as far as possible from every grateful shade from summer sun or shelter from winter wind. In course of time, without doubt,

scorched brule will be replaced by smiling fields and gracious pasture, and shrubbery and shade will be planted or spring up spontaneously in the vicinity of the house, and things will gradually assume an attractive and more homelike aspect—for another generation. But why wait all these years in discouraging ugliness when a little care in clearing and some thought as to the situation of the home site will obviate it almost entirely? The pioneer's life is hard at best, why not do what can be done to ease it?

The first great demand of the pioneer in a wooded country is cleared, arable land. The fear of fire naturally almost amounts to an obsession, and there is every reason for the future farmer to put as broad a belt of clearing as possible between his buildings, home and livestock and the stubborn threatening forest. But surely this does not necessitate the destruc-



Lieut.-Col. W. N. Ponton, of Belleville, Ont., with his father, planted every elm tree seen in the picture, and a long row of maples on the opposite side of the road. The life time of one individual has thus witnessed the development of a splendid avenue of shade trees which are counted as a real asset to the community. Photo taken on Bay Shore, Trent road, just west of Belleville.

tion of every green thing about the house nor is it incompatible with the existence of an oasis of comfort in the centre of broad clearings, cleanly underbrushed and safely removed from the fire threat of the surrounding forest.

The Government has done and is doing much for the comfort and prosperity of these home-seekers, but it seems as if an educative campaign in the direction of making the new homes homelike and attractive would go a long way towards establishing a contented psychology and contribute largely to the success of the project.

This suggestion does not mean that a large grove should be left as a fire danger or that tall unsafe isolated trunks be permitted to remain where they can fall disastrously, nor does it necessarily presuppose that more permanent or ornamental foliage be not planted in the future. Two or three medium-sized conifers with a few

small birches or even poplars allowed to remain properly trimmed and the ground beneath cleared of brush and debris would constitute no danger from either fire or wind fall, if the site is properly chosen and conditions would be obtained in the beginning that it will otherwise take years to develop. It might take a small amount of time to restrain the clearing fires just when time is most valuable and work is pressing, but I am certain the greater contentment and comfort that would ensue would be of inestimable benefit and in many cases make all the difference between ultimate success and failure. Sincerely,

P. A. TAVERNER.

### THE FORESTER'S BUSINESS.

"The business of the forester is to manage the forest," observes the Australian Forestry Journal. "A great deficiency in the past has arisen from the fact that forest officers have seemed to think their greatest responsibility was to administer an Act and Regulations. They have lived in offices, stifled in an atmosphere of red-tape, and losing sight of the big point at issue—the satisfactory treatment of the trees in their forests. Regulations are an aid to management, but the administration of them will not make trees grow nor produce good timber.

"The foresters of Australia must go into their forests and live among their trees, studying them, and understanding them, and always remembering that what they do to-day will bear fruit in years to come. The forests are the property of the people—not the people of to-day, but their children and their children's children for all time. With the political barriers removed there will be no excuse if the heritage of future generations be squandered in a revelry of administration obscuring the sound investment of management."

### FIRES SWEEP HAY FIELD.

Forest fires are continuing their ravages throughout Algoma district and dense smoke overhanging the river detained many vessels, which were compelled to anchor at the Soo before being able to proceed up the lakes. Just outside the Soo a big quantity of hay along the line of the C.P.R. was caught in the path of the fire and destroyed, and farmers kept their horses and cattle tied to wagons in readiness to escape with what they could take with them in the event of the fire destroying their homes.

## THE EMPIRE GETS TOGETHER IN FOREST CONSERVATION



British Government Has Summoned an Imperial Forestry Conference in London to Consider Urgent Forest Problems.



Canada's forestry problems will be brought before a round-table conference in London, England, next December or January.

Under authority of the British Government, a meeting has been announced for the purpose of considering the present position of the timber supply in all parts of the Empire, the policies of forest conservation now in force or in prospect, and the possibilities of arranging closer trade intercourse in wood materials. Leading societies, trade associations, Government Forest Departments, and others will be invited. Arrangements are being completed by the "Interim Forest Authority" at London, and dates are being arranged so as to coincide with the Empire Timber Exhibit, an event of wide importance and interest.

It is also proposed that out of the Imperial Forestry Conference should be developed a permanent Bureau of Information on Imperial forestry affairs, which, doubtless, would extend its functions to matters of inter-Imperial trade.

About four months ago, the summoning of an Imperial Conference and the organization of a Bureau of Information was suggested by Mr. Robson Black, Secretary of the Canadian Forestry Association to leading forestry authorities in Canada, the United Kingdom and other Dominions. The proposal met with such a happy reception, particularly on the part of Sir John Stirling-Maxwell of Glasgow, that it was placed before the Royal Scottish Arboricultural Society, the English Forestry Association and other bodies, their endorsement being readily given. The approval of the Interim Forest Authority at London was next obtained and steps were at once taken by the chairman and secretary of the latter body to formulate a programme and issue invitations.

The Canadian Forestry Journal is confident that the Conference will have far-reaching effect

in stimulating the forest conservation cause in this and other Dominions.

A letter received from Mr. A. G. Herbert, Secretary of the Interim Forest Authority follows:

Interim Forest Authority,  
Hotel Windsor, Victoria St., S.W.  
Robson Black, Esq.,  
Secretary, Canadian Forestry Assoc.,  
Ottawa, Canada.

Sir,—I am directed by the Interim Forest Authority to refer to your letter of the 14th of May last, addressed to Sir John Stirling-Maxwell with regard to the establishment of an Association competent to act as a clearing house for forestry information, and as to the holding of an Imperial Forestry Conference in London, and I am to thank you for your suggestions, which are of great interest to the Authority and have been discussed with representatives of the English Forestry Societies and of certain departments.

As a result of the informal discussions which have taken place the Authority have applied to the Treasury to sanction the necessary expenditure for an Imperial Forestry Conference, to be convened in connection with an Exhibition in London of Empire timbers, which is being arranged by the Department of Overseas Trade to be held in London in December or January.

I am to add that the Authority are taking steps to arrange for a committee to be assembled to organize the Conference, such committee to include representatives of the leading societies and trading associations interested in forestry and representatives of certain departments.

It is proposed that this committee should consider some suggestions, which have been prepared for discussion, with regard to the scope of the Conference generally, and as to the services, societies, etc., to be represented.



Courtesy, "World Wide."  
The first flight of an aerial forest patrol in Canada. Photograph taken near Grand Mere, Quebec,  
of Lieut. Graham in a flying boat.

# IS THERE PROFIT IN PLANTING TIMBER TREES?

By G. C. Piché, Chief of Forestry Service, Quebec,  
Before Woodlands Section, Canadian Pulp and Paper Association.

## Public Prosperity Demands it and Financial Rewards Invite it—A Thorough Study of a Live Topic.

*Six million acres in Quebec, useless for agriculture, demand immediate re-planting with trees. Does it pay to plant a timber crop? Mr. Piché's conclusions are strongly in the affirmative. Who shall reforest the cut-over lands? Several solutions are suggested. Legislation is needed to protect the tree planter from a ruinous increase in local assessment.*

We must consider the question of a progressive policy of reforestation for the Province of Quebec.

It is rather surprising that a country so rich in forests as ours it should be necessary to discuss this point, but those who have travelled throughout the country have been surprised to see how quickly the forest has disappeared from the shores of the St. Lawrence and also how the cost of lumber and pulpwood has always been on the increase.

First of all, the plantations require so many decades to produce results that it will prevent many persons from investing part of their money in this operation. Yet, in Europe many of the old families have retained their rank through the revenues that they derive in the management of forests planted by their ancestors.

There is no reason why farmers, large corporations, the towns and the government should not consider this matter in a broad view. There is no use in hiding the truth: there are in this province millions of acres of land that have been impoverished either by improper cultivation or by wasteful lumbering, whilst others have been ruined by repeated fires. According to the census reports there would be about three million acres of such lands owned by private people here that would require immediate reforestation. It is certain that upon the timber limits there is also a certain quantity, but as we have no definite survey of same we can only say that its area is very large, perhaps equivalent to that of the private lands.

### Why Plant the Waste Lands?

The reasons that would induce us to plant the lands not fit for cultivation would be the following:

1. To establish a forest cover on these lands so that they may be again put into value and rendered productive of revenue;
2. To prevent, as in the case of shifting sands, the devastation of the adjoining lands;
3. To increase the amount of timber per acre in the woodlots or timber limits. The studies made of cut-over lands show that, in numerous sections, the stock left is very low and if we consider the forest as a capital, it will naturally take many years before the compound interest accruing each year by the annual growth of the taxes will form a sufficient amount of timber to pay the expenses of lumbering the tract a second time;
4. It will be necessary, in many cases, to introduce new species in the forest, especially in the glades which will increase its wealth;
5. To protect the headwaters of streams; it is a well-known fact that the forest is a great power to retain the moisture and regulate thereby the seepage;
6. To shelter the basin of the waterworks. It is not necessary for me to insist upon the good qualities of the water that is found in the gentle streams shadowed by trees in comparison to the poor water found in the ugly brooks running in the open;
7. To furnish the necessary supply of timber for the farmers and also for the lumbermen or papermakers. The increased development of the lumbering industries, especially that of pulp and paper mills, has produced such a big demand upon the forest that we can see, within

a relatively short time, some of the companies having either to reduce their production or to purchase new timber holdings. Owing to the enormous amount of capital invested, those interested must necessarily seek for a continuous supply of their raw material;

8. The ownership of waste lands by a private owner is such a burden that, too often, the yare abandoned and fall to the charge of the rural municipality, whereas if they were stocked with trees they would have a sufficient future value to induce the owner to pay his taxes.

### Does it Pay to Replant?

There has been yet no complete survey made of the plantations executed in Canada, as many of these plantations are either too young or of perimental purposes. Therefore we are compelled to seek our information from other sources. However, from the studies made here upon the growth of trees in height and diameter, we can see that the results recorded elsewhere will certainly be obtained also in this country. The State of Massachusetts has published a booklet entitled, "The Older Plantations in the Commonwealth of Massachusetts," in which you will find information that will please anyone interested in the matter. For example, a plantation made by John Tingwick, of white and Scotch pines, has produced in 38 years from 10,000 to 17,000 feet per acre. Those made fifty-five years ago, on the property now held by the Misses Dawe and Hobert have produced trees running from 6 to 17 inches in diameter, and the yield was estimated at 43,000 feet per acre. As you see these results are very good; the tabulation of all these various inventories has enabled the Forest Service of that state to publish an estimate of the future production of white pine and we find that same, on an average quality of soil, will be as follows:

At the end of 25 years, 32,800 feet b.m.

At the end of 50 years, 46,500 feet b.m.

At the end of 60 years, 53,200 feet b.m.

### The Real Profit.

It will be interesting to know what will be the financial return of this investment, and a good forester could not induce anyone to plant without saying what will be the ultimate results of the work. In the above cases the forester has first taken into account the value of the land, calculated at four dollars per acre and which naturally must pay a rental; then come the expenses of planting which were estimated

at seven dollars per acre; the taxes must be paid as well as the annual charges of maintenance and protection against fires. Then, all the money spent at the start and afterwards must necessarily pay a rate of interest which was calculated at five per cent. We find that, after deducting all these expenses from the gross returns of the sale of the timber produced, the plantations would give the following net profits:

At the end of 30 years, \$24.85 per acre.

At the end of 40 years, \$102.57 per acre.

At the end of 50 years, \$248.50 per acre.

At the end of 60 years, \$90.17 per acre.

But if the rate of interest was 6 per cent instead of 5, the financial returns would be as follows:

After 30 years, a loss of \$4.44 per acre.

After 40 years, a profit of \$115.76 per acre.

After 50 years, a profit of \$151.97 per acre.

After 60 years, a loss of \$114.30 per acre.

It will be seen by all these examples that the best time to cut a white pine plantation would be when it has reached the age of about fifty years, that is when the annual increment in volume will begin to diminish.

### Does Spruce Planting Pay?

Of course the pulp and paper makers are more interested in the question of spruce plantations. Here I must say that we have no positive American nor Canadian data on this subject, and we must use the European figures; they are also very satisfactory. We find that, on an average quality of soil and locality, a spruce plantation may produce the following quantities of timber. Taking all the material over three inches in diameter at the small end:

At the end of 30 years, 6,700 feet b.m., or 11 cords per acre.

At the end of 40 years, 21,600 feet b.m. or 35 cords per acre.

At the end of 50 years, 36,700 feet b.m. or 61 cords per acre.

At the end of 60 years, 50,600 feet b.m. or 84 cords per acre.

In admitting that these figures could not yet be obtained in this province, we can by reducing them by, say, one-third, arrive at good conclusions:

After 20 years the stand would furnish 7 cords per acre.

After 40 years the stand would furnish 20 cords per acre.

After 50 years the stand would furnish 36 cords per acre.

After 60 years the stand would furnish 50 cords per acre.

Those who have had the chance to see the national forests of France and of Germany will admit with me that these figures are not exaggerated because every spot of these forests is devoted entirely to the production of trees, and of good trees, whereas in this country the good trees will only form, too often, an insignificant proportion of the stand, the remainder being occupied by swamps, inferior species or blanks.

It would be therefore of capital importance for the future operators to be assured that instead of cutting as we do now from four to ten cords per acre, they could find from twenty-five to fifty cords after an interval of thirty to fifty years. I need not insist upon the effect that such a yield per acre would have on the cost price of lumber; and also on the value of the forest property. This brings us to the subject of:

#### Who Must do Reforestation?

Owing to the fact that no practical returns can be expected before at least thirty years after the plantation, it requires therefore continuity or almost permanency in the possession of the property to be reforested. The problem is easily solved as regards the private lands: it will be a sound and profitable investment for the farmer, the towns and the corporations owning some private lands not fit for cultivation to go into this business, as they will do a national work and also create an excellent and steady source of revenue for themselves.

But when we come to the question of reforesting the timberlands leased from the government, the problem is more complex. Though I have studied it a long while, I have not yet come to a satisfactory conclusion. Will it be better for the government to do this work exclusively or should they rather allow or compel the limit-holder to make it for and by himself or should both co-operate in the plantation. The latter alternative may be the more logical since the government owns the soil and keeps the title of the property, it might then furnish all the planting material required and also the technical direction to do the work, whereas the limit-holder would defray the expenses of replanting. Someone has raised the important question, "Would the limit-holder continue to pay the ground rent on the parts of his limits that have been reforested?" I think he should continue to do so, if he wants to retain his

lease, but I believe that his share of expense, that is the cost of planting, should be kept separate and returned to him as a deduction on stumpage charges either at the moment of the plantation or with the accrued interest of say three or four per cent when the trees will have reached maturity. This plan is not altogether satisfactory to me, and I just present it as a basis for discussion rather than as a remedy to the difficulty.

#### To Encourage Reforestation.

The first measure to adopt for the welfare of the plantation is unquestionably to give them a satisfactory protection against fires. It would be ridiculous to make a plantation on a tract that would not be easily reached and defended against forest fires.

#### Cut Down the Fires.

We must carry on further the policy of protection against forest fires; we have already done a good deal in that direction, but we find that much of our forests is still vanishing away in smoke, and this spring we have had several big fires in the Lake St. John and the St. Maurice districts; most of them being caused directly by the railways. Nobody can dispute that fact as we have secured complete evidence in each case establishing that the railway engines have been the cause of two large fires, one at Vandry and the other at Timbrell on the Transcontinental Railway. I firmly believe that we cannot allow our forest wealth to be depleted in such a manner, and the time has come to see that each engine travelling through a forested district will burn something else than coal or wood. We have water powers in abundance and we should study the electrifying of the railways in the forested regions. Someone will say that this may be too expensive, but it will be less expensive than the burning of fifty square miles of timber limits per year, and besides, we will be thereby developing our natural resources and diminishing at the same time our dependence for coal upon our neighbors. If we cannot electrify the locomotives, we could have them burn oil, as is done in the Adirondacks and as was done with success by the contractors who built the Gouin dam. Anyhow, the railways will have to burn something else than coal or wood and I hope the Pulp and Paper Association will support any movement in this direction. Many fires may be attributed to the poachers, the fishermen and hunters. Nobody should be allowed to roam at will in the forest. We should make it a close property and oblige everyone



to have a permit before entering in same. More preventive organizations should be made; it is much easier to prevent an ill than to cure it, and this is especially true of forest fires. We should have more patrols, telephone lines connecting all depots and observatory towers, etc.

To facilitate the work of the hydroplane service which is being inaugurated, we should establish in connection with the Geodetic Society more lookout stations.

Much has been done and said by the different protective associations which are doing splendidly, but we must complete our protection service so that the fire danger will be totally eliminated and then we can plant, but not before.

### Protection From Taxes.

In regard to private lands, an important point is that of the taxes. The valuation of the properties reforested should not be modified just after trees have been set. A law should be enacted as early as possible to protect the citizens who have the courage to reforest against the unjust raising of the land valuation and thereby of their taxes. I contend that for at least thirty years the first valuation of the land planted should not be modified; the appraisal could take place to determine then the actual value of the forest crop separately from that of the soil and this valuation should stand for one decade at least. The ideal would be to repeat these appraisals at each interval of ten years after the first period has elapsed.

### Allocate the Mills.

I think the time has come for the government to exercise a full control over the wood-working establishments in this province, as we

find too often sawmills being located in a locality where there is not enough wood supply to justify their appearance. Naturally the mill owner, to obtain his raw material, must get it at the expense of the adjoining limits and this is the beginning of the timber speculation of which we have suffered so much. All the wood-working establishments in the province should be licensed and compelled each year to obtain a permit to operate. The government will then be in a position to determine if they have enough timber lands to justify their operating and to prevent enlargements when there is no supply in sight.

### Punish the Wasteful!

Up to the present we have found the lumbermen of this province ready to co-operate heartily with the government in all the reforms made by the administration. Our province can boast with justice of having made great progress through this co-operation. Now that the lumber industry in this province is in a rather stable state, we can look ahead and adopt a definite policy of reforestation and of management of our forests. We should cause those who waste their forest through bad lumbering to replant their holdings at their expense, while those who have done all they could to lumber correctly should be helped to the fullest extent. We should endeavor to make every acre of waste land and of timber land produce the fullest quantity of timber possible. We can make this province the largest timber producer in the world, not only in lumber but also and especially in pulp and paper products and I am sure that with the spirit, the energy and the co-operation of all we will undoubtedly realize our ambition.

---

## SETTLING LAND DOES NOT SETTLE THESE ACCOUNTS

---

A settler near Kedgewick, New Brunswick, taking the "personal liberty" point of view, started fires to consume a few piles of brush. He broke the law in that he did not take out permits and follow safety regulations.

This is the result:

Loss to the lumbering village of Kedgewick, about \$150,000.

Householders lost between 35 and 40 houses.

Three lumber mills were destroyed, plus lumber piles, and three by five miles of territory was burned over.

## WHO WILL PAY THE FORESTRY PIPER?

The following portions of an article in the "American Lumberman" by B. A. Chandler, have an interesting relation to the contention of Canadian conservationists that the Provincial Governments, notably of Ontario and Quebec, and New Brunswick, are "cashing in" each year on their forest resources and selling the capital assets regardless of the effect on the future interest returns.

Of course, there is a handy rejoinder that the provinces do not know their timber resources and therefore estimates of excess cutting are speculative. A lawyer might comfort himself with such a thought, but exceedingly few lumbermen or professional foresters will. It has frequently been urged that Ontario, Quebec and New Brunswick will soon have no other alternative as a matter of self-preservation, than to put back into replacement account the bulk of income now derived from forest taxes.

Mr. Chandler is discussing, not the Canadian position, where the Governments own the forests and are masters of the situation, but the American dilemma consequent upon private ownership of the nation's main timber supply.

### No Future Supply.

"The public in the long run, gets what it wants. Many a city wanted an electric railway, purchased it at the price of an unlimited franchise, and would not give much to be rid of its bargain. Such cities are repenting in 'sackcloth and ashes' that they did not look farther and think deeper before making their demands. Yes; the American public gets what it demands, but it is sometimes sadder and wiser because of the unforeseen results of its action.

"At present much is said about the failure of the lumber industry to provide a future supply of timber to take the place of the crop now being harvested. Evidently some now feel that it is time for the pressure of public sentiment to be applied to the lumber industry.

"That the lumber industry is in a very bad economic condition and that a future supply of timber for our wood-using industries is not being provided are two facts beyond doubt.

### Permanent Management.

"The lumber industry has frankly cut out one region after another without making any provision for a future crop. The pulp companies have been a little more interested in natural

reproduction and planting; but few, if any, of the have provided a permanent supply of raw material. The difficulty with which certain species were obtained for war purposes makes it evident that the supply of our more valuable species is getting low. The condition of any region after a wood using industry has moved on it is so bad that it is, for this reason alone, to the interest of society to establish permanent forest management as soon as possible.

### Private Funds for Planting.

"The growing of timber has already attracted private capital on a small scale. The writer knows of men who have purchased small tracts of cheap land and planted them to forest trees instead of buying a life insurance policy for their children. Private individuals have been doing considerable planting within the last few years and most of it has been done on the investment basis, although very few of them are keeping accurate enough accounts to tell just how much they have invested. However, when a shortage in the supply of timber has forced the price of wood products high enough to attract large quantities of private capital it will be too late to save our forest industries or our communities dependent on them. Private capital can not be depended on to respond soon enough to any situation which requires as much time as it does to grow a crop of trees.

### Broad Issues Suggested.

"If we can hope that private capital will handle the situation and we have not the moral right to force private capital into it, the only way the investment idea can be carried out is by the Federal and several State Governments. Since our governments have not surplus capital for investments, the only way is by bond issues. The principle of bond issues for public improvements which are expected to last over long periods of years has been accepted to a great extent. These public utilities all depreciate in value, and those who get the first use get the best use. A young forest is of no use at first and is continually increasing in value. If it is just to tax the coming generations to pay both the interest and principle on bonds on depreciating improvements it would surely seem just to tax them to carry timber bonds on which both the principal and the accumulated interest will finally be paid by the consumer of the for-

est products. It should be remembered that if this policy is adopted state and national governments will be the largest owners of timber

land and stumpage prices can be made high enough to cover the bonds and the accumulated interest."

## THE BUSINESS SENSE OF OLD FRANCE

Lieut.-Col. H. M. Stickney, jr., who was with the American Expeditionary Force, comments as follows upon conditions in France:

"The French Government, even in peace times, is extremely careful of its forests, husbanding them with the utmost care, even though they have a great deal of timber, far more than is supposed. Everywhere one drives through the country, there are large forests which are kept with all the care of a well-ordered farm. The entire forest administration is a Government matter, and every forest has its forester in the employ of the Government. He has supervision over all matter pertaining to the use and care of the woods, game protection included. He personally marks with paint every tree that is cut, and only marks those trees which have reached their maturity, and are on the point of starting downward in the quality of the timber. When a tree is cut, the merchantable logs are taken to the nearest mill, slung under a gigantic two-wheeled cart with no body at all, being simply a long timber with chains which support the log. Sometimes, if the log is big enough, or two or three logs are carried at a time, the rear end is slung under an extra front wheels and only held to them by the log itself. So much for the timber. The balance of the tree is limbed, sawed into firewood, and piled ready for distribution. The limbs themselves down to the smallest branches are also cut into firewood, and piled, the very small ones being cut with a sort of knife which resembles a combination of Spanish machete and butcher's cleaver, and bound together with withes into bundles about 6 inches in diameter. The early growth of timber is rationed to the different industries and to private families for firewood in accordance with a fixe dschedule which is strictly adhered to, even in peace times. This makes French forests an actual industrial proposition, which under efficient administration, will last the people forever, if they don't have too many wars.

### The Saving Sense.

"It is very interesting to see the users of lumber making use of every possible economy, saving every stick and using the wood in some cases

several times, as long as there is anything left that can be used. For example, in the iron mines at Marron, one of the small mining properties which was not captured by the boche, they timbered their galleries with upright posts from three to five inches in diameter, with a slab usually about three or four feet long, which supports the roof. It was almost inconceivable that such light timber could hold the loads. As a matter of fact, I saw several galleries in which the timbering had started to break down under the tremendous pressure of the burden. When they have finished taking all the ore out of a gallery, instead of letting it cave, timber and all, as we do, they hire a class of men who are from generation to generation in taking out mine called in French 'wood-drawers,' who are expert timbering and do nothing else. These men, beginning at the further end of the gallery, take out these posts and slabs, letting the gallery cave in behind them. The strange part of it is that there are very few accidents. These posts and pieces of slab are used over and over again until they become broken, when the slabs are returned to the little mill and cut up for other purposes. When broken the posts are sawed into ties for the narrow gauge railroads upon which ore is carried out to the main line. The foregoing is a fair example of timber economy as it is practiced in France.

### Rigid Laws.

"The rigidity of French forest laws is well shown by a case which happened in the early spring of 1918 when one of my captains ran out of wood for use in his company kitchen. He was camped in a big forest which was probably 4 miles square, and he cut one old maple tree which was hollow one-third of its length, and which should have been marked by the forester for cutting years before. He cut it close to the ground, covered up the stump and used all the wood for firewood. The forester on one of his inspection trips, found the stump and fined the captain 34 francs (about \$6) for cutting the tree, as it had been agreed between our army and the French that no trees would be cut for wood other than those specified by the forester

and supervised by our quartermaster department. The captain had to pay the fine out of his own pocket.

"Some time later, in fact just before the St. Mihiel attack, a French balloon station established itself near my headquarters in the same forest, and to make a place for their balloon bed, they cut several large trees, with the full authority of the forestry officials, of course. It became necessary for me to build some dug-outs and bomb-proofs, and as these logs which they had cut had laid in the ditches for some time obstructing the drainage, I took them out and used them in the roof of my dug-outs, using two layers of logs and about three feet of broken stone. The logs were not cut or injured in any way, and yet the French forester measured each log carefully, and charged it up against the United States Army. When you stop to think that all this happened close to the front line in an area which was entirely under the German barrage zone, you will get some idea of how the Frenchmen take care of their forests.

"The one thing that strikes me about the whole industrial system is the great economy of raw material and money. Labor is apparently the least of their worries."

### WIRELESS MUSIC AT SEA.

Like all well-regulator ships, the transport "George Washington" has a phonograph. It also has wireless telephone equipment of the latest design. On a recent occasion the phonograph horn and the telephone transmitter were brought face to face, and the music started. A hundred miles away, soldiers and sailors on the transport "President Grant" gathered eagerly around a loud-speaking receiver, from which issued the merry strains of song and fox trot, as the concert ship threw its melodious vibrations into space. Within the hundred-mile radius were several other radio-equipper ships, and when the concert was over the "George Washington's" operator was kept busy receiving encores.

## WESTERN AUSTRALIAN PUBLIC SERVICE

### Permanent Position Under Public Service Act

Applications will be received until 30th August, 1919, for the position of Plantation Superintendent in the State Forestry Department. Salary, £408-£528.

Applicants should have had previous experience in similar work and must be qualified Foresters, having a degree or diploma of a Forest School.

G. W. SIMPSON,  
Public Service Commissioner.

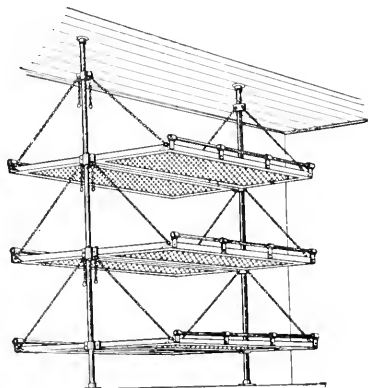

## STEEL BUNKS FOR CAMPS

Included in the well-known line of DENNISTEEL factory, hospital, camp and ship equipment is the all-steel sanitary bunk illustrated. Take up very little room, are comfortable, hygienic and practically indestructible—a permanent investment. Write for particulars and folders on any of the following lines: Steel Lockers, Bins, Cabinets, Chairs, Stools, Etc. Standardized Steel Shelving (knock-down system), Steel Hospital Equipment, General Builders' Iron-work. Ornamental Bronze, Iron and Wirework. Wirework of every description.

THE DENNIS WIRE AND IRON  
WORKS CO. LIMITED

LONDON  
CANADA

HALIFAX MONTREAL OTTAWA TORONTO  
WINNIPEG VANCOUVER

# FOREST FIRE LOSSES IN THE WEST

(Covering 1919 Season to end of June.)

Owing to a most unfortunate combination of adverse factors, the present fire season gives promise of being one of the most disastrous which has been encountered since the Dominion Forestry Branch was established twenty years ago.

In the first place there was very little snow last winter and when this disappeared early in April it was followed by an abnormal period of drought and continuous, high, variable winds, which in some parts, and more particularly in southern and central Alberta, has continued up to the present time. Coincident also with this failure of precipitation, the water in the lakes and streams has never before, in the memory of old settlers, been so low as during the past spring and early summer.

## 1.—Forest Reserves.

A.—Manitoba.—The first serious fires to attack or threaten the forest reserves broke out along the east side of the Porcupine Forest Reserve in Manitoba early in May. These appear to have been settlers' clearing fires that by accident or design got beyond control and resulted in very heavy loss of merchantable timber in licensed berths and of young growth outside. In the other Manitoba reserves no fires of serious magnitude have as yet occurred, although the danger has been acute and many small fires have been fought and extinguished. A factor which increased the difficulty of protecting the reserves is that the labor famine during the past two or three years has made it almost impossible to maintain the boundary fireguards as efficiently as is necessary.

B.—Saskatchewan—During the latter half of May extensive and serious fires raged throughout northern Saskatchewan and did great damage to the forest reserves. It is now believed, however, that the loss is not so great as at first feared, but so far the forest officers have been busy in patrolling and in fighting incipient fires that definite reports are still awaited. The reserves south of Prince Albert appear to have escaped any considerable injury this year up to date. The most noteworthy cause of the widespread fires in northern Saskatchewan appears to have been the unregulated use of fire by settlers, in clearing their lands. The excellent "Forest Fire Act" of Saskatchewan is in

this regard largely a "dead letter" because as yet the Provincial Government has made no organized provision for requiring the settler to secure a fire permit before setting out fire. It is to be hoped that this important section of the Act will hereafter be enforced.

In summing up the general situation in Saskatchewan, the District Inspector says in an interim report dated June 11th: "Starting about a month ago one was, in travelling about the country, amazed at the number of land and meadow clearing fires set out and apparently running at will along the southern boundary of our reserves and fire ranging districts from one side of the province to the other. These fires during the last three weeks swept north almost in a solid line into the reserves and ranging districts. With the extreme weather conditions at the time all efforts to check them were futile. The loss on the reserves and fire ranging districts cannot at the moment be even guessed at, but it is certain that it is large. Every one of the northern reserves was to a large, but unknown extent, burned over. However, I am of the opinion that when we have had an opportunity to map in the burned areas these will probably not be as large as at present is feared."

C.—Alberta—Coming next to Alberta we are confronted with an exceedingly grave condition of affairs. By the middle of May the reserves in southern and central Alberta had become dry as tinder, and indeed the fire situation generally throughout Alberta became extremely serious. By careful patrolling and good fortune the Crownest forest was kept free of fire until early in June when a destructive fire which killed at least fifteen million feet of valuable timber, broke out in the Porcupine hills. This fire was finally extinguished after a three weeks' fight.

Perhaps the worst fire so far reported on any of the reserves is the Sheep Creek fire in the Bow River Forest. This tremendously destructive conflagration originated through the carelessness of a railway laborer who failed to properly extinguish a fire made to boil a pot of tea. It escaped into the Lincham Lumber Company's slash on May 22nd and continued to spread until about July 15th, in spite of every

(Continued on page 382)

THE UNIVERSITY OF TORONTO

and

UNIVERSITY COLLEGE

*with which are federated*

St. Michael's Trinity, Knox, Wycliffe and Victoria Colleges

FACULTIES OF  
ARTS, MEDICINE, EDUCATION, APPLIED SCIENCE, FORESTRY, MUSIC  
DEPARTMENTS OF  
HOUSEHOLD SCIENCE SOCIAL SERVICE

For information, apply to the REGISTRAR OF THE UNIVERSITY  
or to the Secretaries of the respective Faculties.

CLAPP-EASTMAN  
**WIRELESS APPARATUS**

*Quality and Prices "A Little Better Than the Best"*

Complete outfits or parts for Amateur or Professional Use.  
Short Course Training Facilities provided by mutual arrangements.

*Send Five-cent Stamp for Catalog.*

**Radio & Electric Supply Co.**

43 McGill College Avenue, Montreal

Phone Uptown 1522



**FOREST TELEPHONES**

Make the life of the forester better worth living. They relieve him from the appalling loneliness. They help him to keep in human voice touch with foresters miles away.

In emergencies—fire—sickness—hunger—the speed with which they can summon help is marvellous.

Write for full particulars of how to install the Northern Electric Forest Telephone System. Address the Office nearest you.

*Northern Electric Company*  
LIMITED

|          |          |           |
|----------|----------|-----------|
| Montreal | Toronto  | Regina    |
| Halifax  | London   | Calgary   |
| Ottawa   | Winnipeg | Vancouver |

***Northern Electric Forest Telephones***

## Foresters' Equipment

---

MOSQUITO AND INSECT PROOF TENTS  
 WATER AND MILDEW PROOF BAGS  
 FROST PROOF SLEEPING BAGS  
 ALL "WOODS" QUALITY

---

## Woods Manufacturing Co.

DEPT. D.

OTTAWA

**TREES, SHRUBS and SEEDS**

HARDY NORTHERN TREE STOCK

**EDYE-DE-HURST & SON, DENNYHURST**  
DRYDEN, ONT.

Shippers to H.M. Government.

**Hill's Seedlings & Transplants**

ALSO Tree Seeds for Reforesting. Best for over half a century. Immense stock of leading hardy sorts at low prices. Write for price list and mention this magazine. Forest Planters Guide Free.

**The D. HILL NURSERY CO.** Evergreen Specialists  
Largest Growers in America.  
Box 503. DUNDEE, ILL., U.S.A.

**Try This Stump Puller at Our Risk**

The Smith Stump Puller will take out every tree and stump by the roots, clearing from one to three acres a day, doing the work of twenty men. We want you to send for our 3 year guarantee against breakage and our free trial proposition. Address  
**W. Smith Grubber Co.**  
11 Smith Sta.  
LaCrescent, Minn.

**GAGNON & MORISSETTE**

TIMBERLAND CRUISERS  
LUMBER CONTRACTORS  
FOREST INDUSTRIES

CHICOUTIMI, - - P.Q.

**LT.-COL. L. J. D. MARQUIS**

Forest Engineer and Mem. Can. Soc. of F.E.;  
Quebec Assoc. of F.E.; Former  
Mem. Que. F. Service

Timber Factors and Logging Costs  
Facts on Forest Growth and Future Products  
Forest Cruising and Mapping

GIFFARD, - - - QUEBEC.

**Timber Lands Bought & Sold**

Timber and Pulp Wood Estimates.

**R. R. BRADLEY**

CONSULTING FORESTER

Globe-Atlantic Bldg. - ST. JOHN. N.B.

ASK



FOR

**Timber Estimating & Mapping**

Management of Forest Properties.  
Supervision of Lumbering Operations.  
Forest Planting.

**COOLIDGE & CARLISLE**

FOREST ENGINEERS

BANGOR - - - MAINE.

**Timber Estimates****JAMES W. SEWALL**

Old Town, Maine.



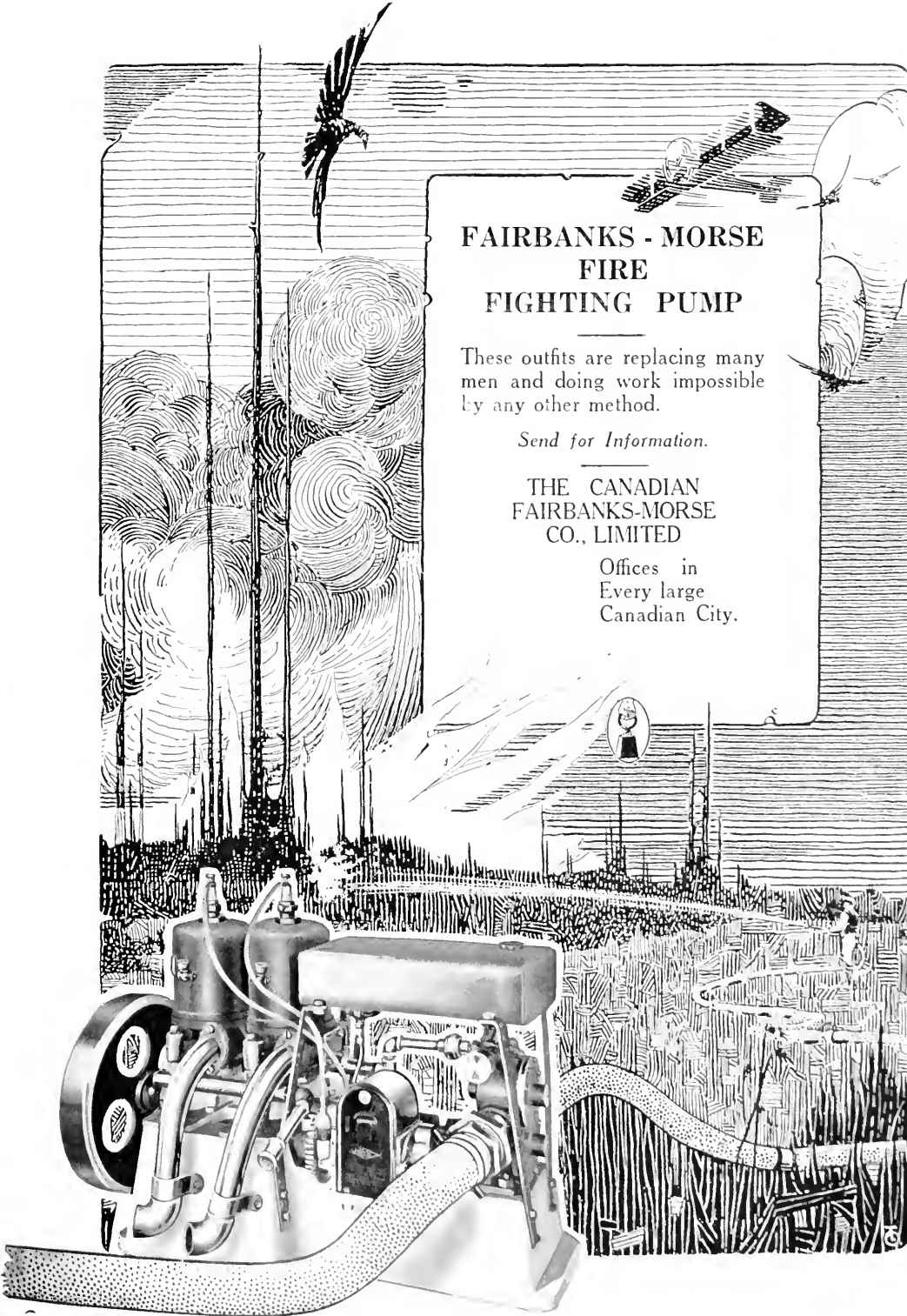

**FAIRBANKS - MORSE  
FIRE  
FIGHTING PUMP**

These outfits are replacing many men and doing work impossible by any other method.

*Send for Information.*

**THE CANADIAN  
FAIRBANKS-MORSE  
CO., LIMITED**

Offices in  
Every large  
Canadian City.

### PROSECUTING SETTLERS.

A large audience assembled at the office of Justice Lemieux of Kedgwick, on the 16th of July, to attend the trial of twenty-one offenders under the Forest Fire law. The cases covered: neglecting slash fires, neglecting to report forest fires to the fire warden, and neglecting to secure fire permits.

Justice Matheson, of Campbellton, presided, Justice Lemieux, of Kedgwick, acting as clerk of court. Forest Rangers Roy, Hocquard, Blanchard, Inspector Brophy, Caretaker Somers and Provincial Forester Prince were present. Assistant Chief Fire Inspector L. A. Gagnon acted as prosecutor on behalf of the Department of Crown Lands.

The court sat for two days, twenty cases being completed at time of writing, fourteen of which resulted in convictions.

The evidence was taken in both French and English, and the department took the opportunity of explaining to the people that they did not wish to deal harshly with the residents, but that the fire law must be observed in the interests of themselves as well as their neighbors and surrounding timber owners. Justice Middleton gave the offenders severe reprimands, pointing out not only the danger of neglecting slash fires, but the terrible destruction rendered by the recent fires in which nearly \$122,000 damage resulted, and in which many of the settlers lost their homes and property. It was stated that thirty buildings were burned and three small sawmills. Insurance covered about one-half the damage. Justice Middleton ascertained carefully the amount of damage each of the offenders suffered by reason of the fire and the fines against those who lost heavily were allowed to stand. It is interesting to note that none of the defendants pleaded ignorance of the slash-burning law, but claimed that they did not expect their fire would do any damage. At the time of the fire, June 12th, the slash and ground was extremely dry and the fire swept over even hay and oat fields in which there was nothing to feed the flames excepting scattered stumps. In much of the area covered by the fire all vegetable matter is burned out of the soil and it is rendered almost useless.

It is hoped that in the future the residents of Kedgwick will carefully take every precaution in burning, as it is considered miraculous that some of them did not lose their lives in the recent fire as well as their property. Several spent the day in the railway cuts to escape the smoke.



**QUEEN'S**  
**UNIVERSITY**  
KINGSTON,  
ONTARIO

**ARTS**  
Part of the Arts course may be covered by  
correspondence.

**MEDICINE      EDUCATION**  
**APPLIED SCIENCE**  
Mining, Chemical, Civil,  
Mechanical and Electrical  
Engineering

**SUMMER SCHOOL      NAVIGATION SCHOOL**  
July and August.      December to April  
26      **GEO. Y. CHOWN, Registrar.**

## UNIVERSITY OF NEW BRUNSWICK

FREDERICTON, N.B.

### DEPARTMENT OF FORESTRY

Established in 1908.

Best of facilities for definite instruction  
and supervision in Practical Forestry.

Surveying, cruising and construction  
work carried on in our own tract of 3600  
acres, with Forestry Camp in the centre.

Competent men from the School at  
present in demand to take up Forest Sur-  
vey work with the Provincial Crown Land  
Department.

For further information address:

### DEPARTMENT OF FORESTRY

University Calendar furnished on application.

C. C. JONES, *Chancellor.*

TABLE OF CONTENTS FOR SEPTEMBER, 1919.

|   |     |
|---|-----|
| How to Attract Birds to the Home, by P. A. Taverner .....         | 339 |
| The Care of Bark Wounds in Trees, by C. L. Meller.....            | 343 |
| Cruising Mahogany in Central America, by L. C. Tilt.....          | 345 |
| Tree Wireless—A New Application, by D. R. P. Coats.....           | 348 |
| When Trees Grow; A Novel Study, by J. S. Illick.....              | 351 |
| Hatching Trees by the Million, by G. C. Piche.....                | 355 |
| Toronto's Woodland School for Children.....                       | 359 |
| Jack Miner's Scriptural Fliers.....                               | 360 |
| Forest Fire Items of the Month.....                               | 360 |
| Memorial Trees, by Dr. Frank Crane.....                           | 361 |
| Future Facts that the Present Must Face, by Hon. E. A. Smith..... | 362 |
| Plea for the Northern Ontario Homestead.....                      | 364 |
| The Empire Gets Together in Forest Conservation.....              | 366 |
| Is There Profit in Planting Timber Trees? by G. C. Piche.....     | 368 |
| Who Will Pay the Forestry Piper?.....                             | 372 |
| The Business Sense of Old France.....                             | 373 |
| Forest Fire Losses in the West.....                               | 375 |

FROM PINGARRA, WESTERN AUSTRALIA.

"Allow me to congratulate you upon the improvements effected in your excellent Forestry Journal."

A READER.

WANTED

## LIGHT RAILS

State whether complete with  
splice or angle bars.  
Give size, quantity, location,  
condition and best cash price  
f. o. b. cars loading point.

Box No. B, Canadian Forestry Journal,  
Ottawa, Can.

## B. M McGRATH

Colonial and Industrial Investments,  
Timber, Pulp Wood Areas and  
Waterpowers.

Newfoundland and Labrador  
Mines and Minerals.

*Reports, Plans and Estimates Furnished*

TRADE REVIEW BUILDING,  
ST. JOHN'S, NEWFOUNDLAND

## MOTION PICTURE MACHINES

---

## STEREOPTICONS

---

**We are fully equipped to  
supply projection  
apparatus on short notice.**

---

**LANTERN SLIDES and  
Motion Picture Film made  
up in twenty hours.**

---

Write for Catalog.

---

PROJECTION DEPARTMENT  
**SUPPLIES COMPANY  
OF CANADA**  
65 SPARKS STREET,  
OTTAWA, ONT.

## FOREST FIRE LOSSES IN THE WEST.

(Continued from page 375)

effort by hundreds of men to get it under control. In the interval the timber loss has been enormous, as several timber limits have been wiped out and very large areas of promising young growth destroyed. It is estimated that fully fifty million feet of fine saw-timber has been killed by this fire up-to-date.

Near the end of May a second great fire broke out on the Stony Indian Reservation west of Calgary, and soon spread to the forest reserves in the Ghost River Valley. This very destructive fire has been fought by a small army of men for seven weeks, and, the latest report received, dated July 16th, states that it is not yet under effective control. Again, in early June another large fire started in the Sarcee Indian Reservation and finally spread westward up the Elbow River, extending however only a short distance into the forest reserve. It was finally placed under control on July 13th. Meantime another very large fire started farther north, between the Red Deer and Clearwater Rivers. Our latest report, of July 16th, shows this fire running south into the Bow River forest and so far defying all efforts at control. As to the exact extent of the damage occasioned by any of these fires, no definite reports are yet available.

The Brazeau and Clearwater forests appear to have sustained very considerable damage, at least three large fires having occurred on each, but owing to rather more favorable rainfall conditions farther north the Athabaska and Lesser Slave forests have fortunatel yescaped so far with comparatively light fire losses.

D—B. C. Reserves—On the British Columbia Reserves also the fire hazard for a time was considerable, but our protective organization succeeded in carrying them through this danger period without experiencing any serious fires.

### 2.—Fire Ranging Districts.

With the exception of the districts in British Columbia an abnormally serious fire situation is reported to have occurred on all the fire ranging districts. The chief fire ranger at The Pas says: "This is the worst fire season that the West has seen for twenty years—woods all dry as tinder even in the muskegs." In Prince Albert fire ranging district heavy losses are reported, and in the Battleford District twelve large fires had occurred before the end of April, covering some 55,000 acres. No Battleford

May or June reports are yet in hand, but it is certain that they will tell of still more widespread destruction in this part of the West.

In regard to the region north of Edmonton, the district ranger says: "All through this district large fires have occurred." One of these fires destroyed the town of Lac la Biche, and the chief ranger reports that another—the one which swept timber berth No. 1900 killed some fifty-five million feet of merchantable timber—the same condition of danger and loss from ber. A May report from Fort McMurray shows fire has been experienced this season even in the Mackenzie Basin.

### No. 3.—Railway Fire Ranging.

From reports received, it is evident that the Railway Fire Ranging Service has done some excellent work this season. For instance, of the numerous fires reported in April, practically all were extinguished before burning over more than 10 to 30 square yards, thus demonstrating the efficiency of the patrol system employed.

With reference to the fires on forest reserves in general, and those in Alberta in particular, it must not be forgotten that the war greatly depleted the administrative and ranger force and also largely stopped the construction and proper maintenance of protective improvements such as trails, telegraph lines, lookout towers, and fire-guards.

With normally effective protective machinery and good laws properly enforced governing the burning of slash by lumbermen and settlers, there is every reason to believe that even in such an abnormally dangerous season as the present, the forest can be adequately safeguarded from fire loss.

THE CANADIAN FORESTRY  
JOURNAL WILL BE SENT TO  
ANY ADDRESS IN CANADA  
FOR ONE DOLLAR A YEAR.

IF YOU WANT A CHEW  
THAT WILL JUST SUIT

YOU ASK FOR

**STAG**

**CHEWING TOBACCO**

RICH AND SATISFYING.

IT IS ALSO KNOWN TO BE  
"EVER-LASTING-LY GOOD"



## Do You Require More Capital?

For ten years, Royal Securities Corporation has been associated with the development and financing of Canada's most successful pulp and paper enterprises. Among them are:

*Abilibi Power and Paper Company.  
Brompton Pulp and Paper Company.  
Mattagami Pulp and Paper Company.  
Price Bros. and Company.  
Riordon Pulp and Paper Company.  
Fraser Companies, Limited.*

Do you desire to pay off floating indebtedness; increase your plant capacity; or acquire additional properties? If so, why not let us suggest ways of financing your requirements? Our Engineering and Statistical Departments are at your disposal.

**Royal Securities  
Corporation  
L i m i t e d**

164 St. James St.,  
MONTREAL

58 King St. West,  
TORONTO

# Canadian Forestry Journal

VOL. XV.

OTTAWA, CANADA, OCTOBER, 1919.

No. 10



FACULTY OF FORESTRY

MAR 12 1920

UNIVERSITY OF TORONTO



Forestry's recreational side - Health-getting on a Dominion Forest Reserve

# Gillette

## Safety Razor

---

A Shaving Service for Everyman - - Everywhere

---

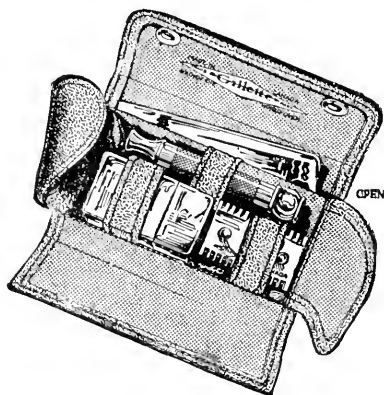

TAKE A  
GILLETTE KIT SET  
(No. 20)  
WITH YOU

There is much comfort in small space in the Gillette Kit Set No. 20. Do not deny yourself the certain luxury of a Gillette shave, when you can stow away the necessary equipment in so small a space.

Whether you go away for two or three days' hunting or as many weeks, you will appreciate the daily five minutes with the keenest of keen edges.

\$5.00 is the price, and to-day's the day to buy.



The Gillette Safety Razor Co. of Canada, Limited, Montreal, Que.





Cutting for reproduction. The strip method in a U.S. national forest.

## CANADA'S FORESTS AS A CROP

*By Clyde Leavitt, Chief Forester, Commission of Conservation.*



### Essential Supplies for Industries Not Maintained Under Present Methods of Woods Management



Too much emphasis can not be laid upon the importance to Canada of her forests, in the support and development of her commercial and industrial life. There is, however, great danger of inadequate attention being paid to the perpetuation of this great resource, so that it may always be available, and to an adequate extent, for supplying the needs of the home population, as well as for further building up the great export trade in forest products which already means so much in our business life.

The forest is a crop, like other crops, the principal difference being the long-time element involved in growing it, and the fact that it is at home on non-agricultural lands, largely valuable for no other purpose. Thus far, our forest industries have largely been supported by the exploitation of virgin timber stands the free gift of Nature, grown without man's intervention or care. The formerly prevalent idea that our timber supplies are of inexhaustible

extent is now known to be a dangerous myth—dangerous because such an idea tends largely to discourage the effort necessary to the perpetuation of the forest on cut-over lands.

In the United States, intelligent citizens are already becoming seriously alarmed at the growing shortage of timber supplies, and much discussion is taking place as to what can be done about it. According to Chief Forester Graves, of the United States Forest Service, the dissipation of the forests in that country still goes on with no let-up. He points out that "exhaustion of local forest supplies, the closing of industries dependent on them, the embarrassment for supplies of the pulp mills and other consumers using special classes of forest products, the generally mounting prices to consumers, are other factors which are calling sharp attention to the effect of forest destruction, and are causing increasing public uneasiness. Leaders of the southern pine manufacturers state

that the bulk of the original supplies of yellow pine in the south will be exhausted in ten years and that within the next five to seven years more than 3,000 manufacturing plants will go out of existence. Already paper manufacturers are embarrassed for supplies. Hundreds of communities are suffering because the resource supporting their chief industry has been exhausted. Sawmills and woodworking establishments close, subsidiary interests can no longer exist, the population moves away, farms are abandoned, roads and other public improvements deteriorate, and whole townships and even counties are impoverished."

#### CANADA'S ADVANTAGE.

It must, of course, be recognized that the situation in the United States is fundamentally different from that in Canada, in that the great bulk of the timber in the former country is on lands held in private ownership and therefore not thus far subject to restrictions as to cutting methods, while in Canada, all but a comparatively small proportion of the forests are on Crown lands, and are therefore subject to such cutting regulations as may be prescribed by governmental authority.

In this lies the hope of the future for Canada, since forestry is, as a general rule, primarily a matter for governments rather than for individuals or even corporations. Since, however, pulpwood can be grown in a much shorter period of time than saw-timber, progressive pulp and paper companies are already considering it to be good business to prepare for the systematic growing of at least a portion of their necessary supplies for the future and are proceeding accordingly. This, by the way, is indisputable evidence that the shortage of pulpwood supplies over considerable areas in eastern Canada is already upon us, were such additional evidence required.

It certainly requires no great powers of observation to determine that in eastern Canada, for example, are enormous areas of cut-over lands which are in an absolute or relatively unproductive condition. These lands are, of course, generally speaking, the most accessible to existing transportation, where stumpage values would be highest and where the existence of a permanent supply of timber would be of the greatest value to all concerned.

#### THE SEARCH FOR LOGS.

Studies made by the Commission of Conservation, in co-operation with the Laurentide, Riordon, and Abitibi pulp and paper companies,

and in collaboration with the Provincial Forest Services of Quebec and New Brunswick show conclusively that the productiveness of the forest is not satisfactorily maintained by present methods of cutting.

Companies are continually having to go farther and farther afield to secure necessary timber supplies, and the cut-over lands they leave behind are, for the most part, not left in a condition that promises the possibility of a second cut within any reasonable length of time.

If a reasonably satisfactory forest stand is to be produced on lands to be cut over in the future, particularly in the mixed forests, some way must be found by which it will be possible to so modify present methods of exploitation as to favor the reproduction of the coniferous species. Protection from destruction by fire is not sufficient, though this is of the first importance, and is a matter in which great progress has been made of late years. Millions of dollars of damage is being done by the spruce budworm and other insects in the pulpwood forests of eastern Canada. The loss of balsam is particularly severe, the spruce suffering less, though still seriously. The withdrawal from prospective utilization of the large volumes of timber so destroyed only serves to make more urgent the necessity for recuperative measures.

One aspect of the problem involves utilization of the hardwood species, at present comparatively valueless, particularly on the more remote limits, but whose increased spread and growth is consistently favored through the continuous removal of the conifers. Our mixed pulpwood forests are rapidly being turned into hardwood forests as a result of this process. The solution of the problem involves finding some method by which the hardwoods can be transported to market and there utilized. Heavy loss from sinkage in stream-driving is the greatest difficulty, though experiments by the Riordon and other companies show that hardwood logs can be driven successfully up to 90 miles. Presumably this may be increased if some feasible method of first partially drying out the logs can be demonstrated. Possibly, also, the use of tractors for log-hauling may assist in solving the problem. New railway construction will assist in some cases.

#### THE HARDWOOD PROBLEM.

At any rate, pulp and paper companies must find some means of transporting and utilizing their hardwoods if they expect to retain their mixed forest lands in a productive condition.

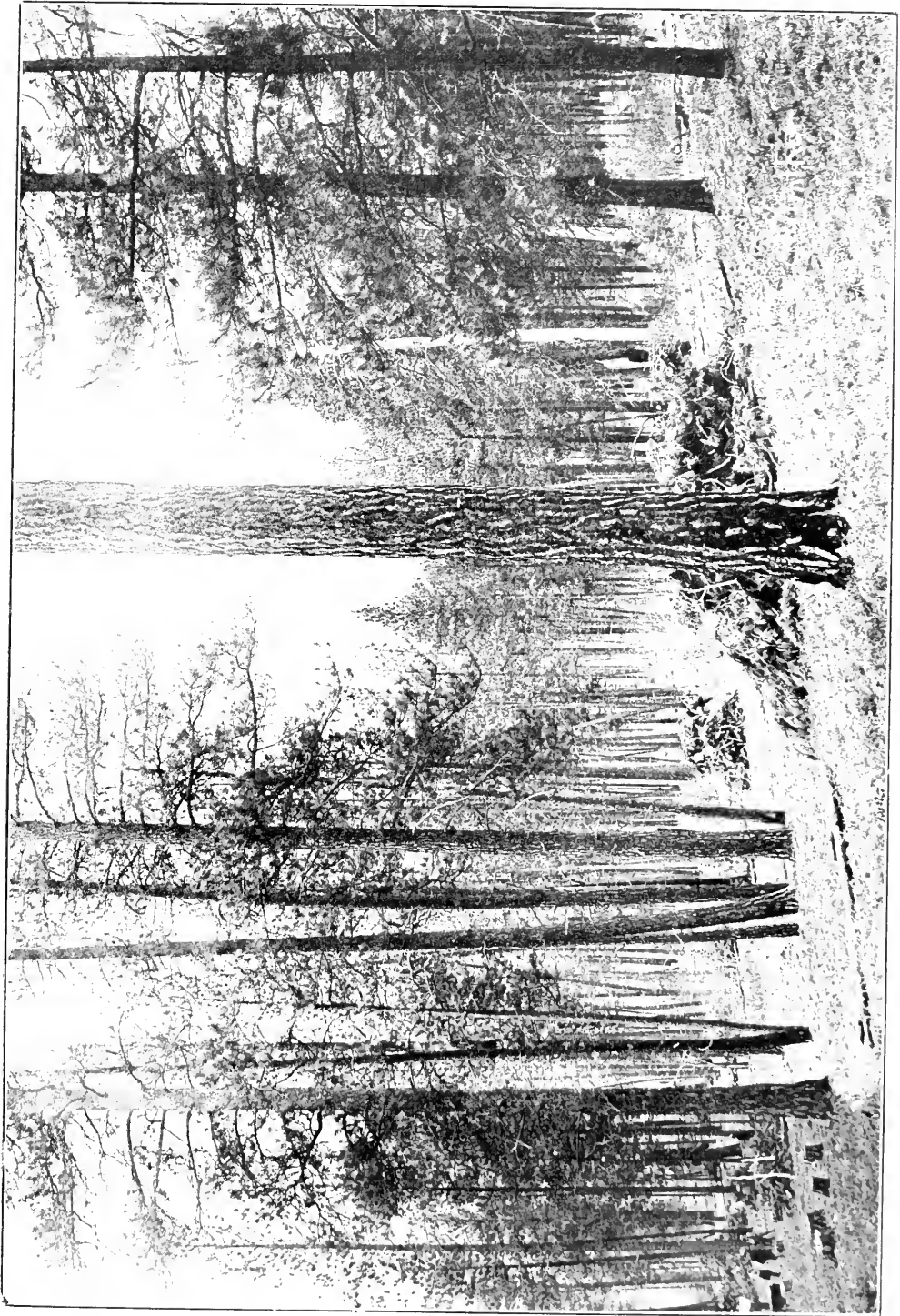

View after logging according to one of the modern silvicultural methods.

Already, it has been shown, by the Laurentide Company, for example, that birch can be successfully used in mixture with spruce and balsam in the manufacture of groundwood pulp for newsprint. There is also a good market for hardwood lumber.

The determination of what cutting regulations are necessary, in order to ensure the adequate reproduction of the forest on cut-over lands, is a problem which will tax the best efforts of both the forestry profession and the operators. While the problem still awaits solution, it is being attacked by the Commission of Conservation, the Dominion Forestry Branch, the Quebec Forest Service, the New Brunswick Forest Service, and by a number of the more progressive pulp and paper companies, such as the Laurentide, Abitibi, and Bathurst concerns. The first three of these companies are, in addition, taking time by the forelock, by initiating extensive planting programmes, to supplement the natural growth on cut-over lands. The inauguration of similar work by other concerns is more than likely.

Canada's forest industries have experienced a phenomenal growth. The value of the products of the lumber industry was, for example, \$115,884,905 in 1917, an increase of 68.40 per cent over 1915. The payroll of employees on salaries and wages amounted in 1917 to upwards of \$21,000,000, according to the Bureau of Statistics. Census figures for the pulp and paper industry show that in 1917 there were 83 mills in operation, with a production of \$96,340,327. The total cut of pulpwood that year was 3,122,188 cords, of which approximately one-third was exported to the United States, presumably cut from freehold lands. In the face of this large exportation, valued at approximately \$8,000,000, and the exportation to the same country in the same year of 473,849 tons of wood pulp, valued at \$23,049,292, the provinces of eastern Canada are faced with a demand from United States interests holding Canadian timber limits, for a modification of the present restrictions upon the exportation of pulpwood cut from Crown lands.

#### DRAWING ON CANADA'S STORES.

Already the United States supplies one-fifth to one-third of its pulpwood requirements and over 11 per cent (1917 statistics) of its wood pulp requirements through importations from Canada. If these growing requirements are to be met continuously, in addition to meet-

ing the increasing demands for pulp and paper from Great Britain and other European countries, it is obvious that steps must be taken to retain our forest lands in a continuously productive condition. Canada is a pulp and paper country par excellence, and the amount of business she can do in the future will be limited only by the supply of raw material.

The importance of this viewpoint is also indicated in the matter of provincial forest revenues. Quebec, for example, derived in 1917 a revenue from her Crown timber lands aggregating \$1,568,157. The corresponding figures for Ontario were \$1,695,703, and for New Brunswick \$443,848. All these may be greatly increased, if adequate attention is given to maintaining the cut-over lands in a productive condition, and if sufficient care is given to the important matter of scaling methods.

In the solution of the problem, every consideration must, of course, be given the economic aspects of the situation, so that the remedies shall be practical from the viewpoint of the operator, as well as correct from the technical aspect. The problem is by no means solved, but there is at least great encouragement in the fact that it is being attacked by the combined efforts of both timber-owners and governmental agencies.

#### BEETLES ARE KILLING THE YELLOW FIR IN BRITISH COLUMBIA.

Dr. J. M. Swaine, Chief of the Division of Forest Insects, Dominion Entomological Branch, visited Victoria in the latter part of August, and conferred with officials of the Provincial Forest Branch with a view to securing provincial co-operation with federal effort in destroying insects noxious to timber.

Bark beetles, Dr. Swaine stated, had been killing the yellow pine in the interior for some years. The federal authorities, however, had been working out a suitable and practical method of control, the object being to secure, by proper logging operations, the removal at once of certain infected trees, to clear out the beetles and so prevent them from spreading into the green timber. Conditions in Stanley Park, Vancouver, Dr. Swaine asserted, had greatly improved following the adoption of methods of insect control by the Vancouver Park Commissioners, after he had made an exhaustive report some years ago.



Threading seedlings into planting boards in portable cabins.

## WORKING FOR POSTERITY

*By Allan Donnell, of the Editorial Staff of the Commission of Conservation.*

### Through Private Initiative a Start Has Been Made in Regeneration of Eastern Canadian Forests

Making posterity the goat was long a habit of municipal, provincial and federal governments in Canada. It provided an easy way for them to get utilities that they could not pay for and it prevented troublesome criticism by those who did the voting. Of course it was impossible to obtain posterity's assent to this practice, but that little democratic principle caused almost no concern. Surely a dutiful posterity would feel honored in being called upon to assist its forebears in obtaining luxuries that were beyond their means and, besides, if the former were lucky, it might have the use of the second-hand utilities in due time. So it became a common thing when a new street was deemed necessary to charge a generous portion of the cost of posterity. Or if political considerations suggested a railway through an unsettled section of country, or across the continent, posterity was blunderbussed into helping

to pay for it. Perhaps this delightful fashion of "passing the buck" might have been "put over" had not posterity's most honorable ancestors exploited and pillaged vast portions of the virgin resources which would be required to liquidate the debts of a prodigal past. Forests were slashed and burned with a recklessness that made Nero's little show look like a nickel movie. Inefficient farming resulted in the literal mining of the fertility from hundreds of thousands of rich farm lands. Inadequate methods of mining minerals and coal frequently led to the permanent loss of millions of dollars worth of these products. Even the fish of the sea and inland waters were wasted by the scowload because of insufficient markets, or because certain species did not appeal to the epicurean tastes of generations of improvident spend-thrifts.

Of course, it would be expecting too much to hope that such practices were only of the past. Inherited tendencies die hard. The iniquities of the fathers are often continued into the third and fourth generation. But Dame Nature has her own methods of making naughty nations be good. The truth in the story of the prodigal is as old as human history. Spendthrift nations, like spendthrift individuals, sooner or later come to the time when they must face about, admit their errors and seek a fresh start, or perish in their sins. In so far as the gifts of nature are concerned this turning about is synonymous with conservation, or working for posterity. It is the antithesis of the policy of charging the cost of the night's orgy to the future. It is simply recognizing that everyone must eventually pay in some form for his own fun.

#### A CHANGE IS COMING.

Fortunately, there are indications of just such a change of heart in the treatment of certain natural resources in Canada. A generation ago the vast spruce and balsam forests of Eastern Canada were considered to be inexhaustible. Because men wished to think so, it was the common opinion that good-natured, generous Nature would provide a new forest long before all the virgin stand was converted into gold. It was argued, therefore, that a very sizable spruce could be grown in about thirty years argo, natural reproduction would provide new forests in plenty of time. *No investigations had been made* of the growth of trees in Canadian forests. Instead, the work on European forest plantations which was not a parallel at all, as well as forecasts of natural reproduction in the Adirondacks, carried out by leading American foresters were applied to Canadian conditions. Time has shown that such applications were not in any way justified and as if to make the error still more glaring it is now known that the Adirondack estimates of twenty years ago were, like the report of Mark Twain's death, greatly exaggerated.

In addition, the appearance of hardwoods on cut-over lands, the effects of plant diseases and forest insects, and the awful wastage due to forest fires were left out of the reckoning altogether. The result is only an illustration of the futility of guessing where accurate, painstaking research should have been applied. Nature never unfolds her secrets to half-hearted, dilettante students, or to the unobservant woodsman. And so, although the day of Canada's virgin forests is already far spent, definite

action has at last been taken to carry out such essential studies in pulpwood forests. Naturally many years will be required to obtain conclusive results, for trees are not products of a single season.

#### PRIVATE COMPANIES TAKE THE INITIATIVE.

It is rather a striking circumstance that perhaps the most comprehensive studies now being undertaken in Canada are largely the result of private initiative. Forestry, on account of its long-time elements, has been viewed as being properly a state activity. But the governments concerned failed to take adequate action in time. Hence such companies as the Laurentide Company, the Riordon Pulp and Paper Company, and the Abitibi Power and Paper Company have commenced, in conjunction with the Commission of Conservation, a series of such studies on their pulpwood limits in Quebec and Ontario. Mr. Ellwood Wilson, forester of the Laurentide Company, and a close student of European forestry methods, has been a prime mover in this important work. Coincidentally, a policy of reforestation has been adopted. During the spring of this year the Laurentide Company planted approximately 1,000,000 seedlings and the Riordon Company 750,000. The greater proportion of these are Norway spruce grown in American nurseries from seed imported from northern Europe. The provincial nursery at Berthierville also furnished large numbers of these seedlings. It is unfortunate that native spruce seedlings could not have been obtained, for Norway spruce have never been grown except as ornamental trees in Canada, and their behaviour in forest stands is problematical. Close comparison of conditions in the natural habitat of the Norway spruce and those in Quebec encourage the hope that the imported seedlings will develop satisfactorily. A ready market could be found at the nurseries for seeds of the native spruces, but so far there has been no attempt at collecting them in a large way. Small areas of white and Scotch pine were also planted on land where the soil conditions seemed most favorable for their growth. The planting was done in rows four or five feet each way, by gangs of forty to fifty men with the same number of boys to "drop" the seedlings as the holes were made. Such gangs planted from 25,000 to 30,000 seedlings each per day during the short planting season in May. Judging from the results obtained on small plots in previous years, it is expected that from 75 per cent to 90 per cent of the seedlings will grow.

#### A BIG NURSERY BEGUN.

One of the obstacles in the way of planting forests in Canada is the scarcity of comparatively cheap labor. In this particular the Quebec companies at least, possess an advantage, for they are in a position to obtain labor at reasonable rates of wages. The planting season is necessarily short, so the companies endeavor to provide their labor with other work during as much of the year as possible. To a limited extent the forest nursery at Proulx, Quebec, assists in this, although, of course, the outstanding purpose of the nursery is to ultimately supply the annual planting requirements of the Laurentide Company with, possibly later on, that of other companies as well. This nursery

of moisture. The seeds were planted in rows two or three inches apart in small beds, much the same as seeds in a vegetable garden. An abundant water supply was obtained by pumping water from nearby springs into a large tank, from which it was piped to all parts of the nursery. Irrigation was used but sparingly in order to increase the hardiness of the seedlings. The tender young plants were kept carefully shaded from excessive direct sunlight and the beds were covered with canvas and straw throughout the winters.

#### HOW THE SEEDLINGS ARE HANDLED.

During the second year the tiny seedlings are carefully "lifted" from the beds and transplant-



Plantation four years old in a Quebec sand area.

was established about three years ago and is at present under the general supervision of Mr. Ellwood Wilson with Mr. R. W. Lyons, a graduate in Forestry at the University of Toronto, as resident forester in charge.

Twelve acres of land were carefully stumped and the ground thoroughly cultivated. Owing to the inferior nature of the soil, fertilizer was necessary and was obtained by mixing farm-yard manure and bog-muck in equal parts and allowing it to stand under cover for a year before it was applied to the land. This produced a well-rotted fertilizer which mixed well with the soil, without leaving the latter too open and, therefore, subject to too ready evaporation

ed in rows ten inches apart by five inches in the row. This transplanting requires careful supervision. As it is a much slower operation than that of "lifting," the plants are "heeled in" in wide, shallow trenches as soon as they are taken from the beds. This makes it possible to keep the roots thoroughly moist, without delaying the "lifting" process. The transplanting is done mainly by boys and girls with the aid of a few men to dig and fill in the trenches. The seedlings are carried from the heeling-in beds to portable cabins placed near the transplant beds. Here they are "threaded." For this purpose planting-boards, about eight feet long and five inches wide and provided with

notches on one side at intervals of five inches, are used. A seedling is placed in each notch with the roots projecting over the edge of the board. A second board is then clamped on snugly and a boy, or a girl, conveys them to the trenches where the earth is pressed firmly against the roots, the clamps removed and the process repeated. The portable cabins are necessary to protect the tender seedlings from too much sun drying. No seedlings are removed from the nursery for final planting until they are at least three years old.

#### PLANTING STOCK AVAILABLE.

Already this nursery contains 3,500,000 seedlings and transplants, chiefly Norway spruce, white pine, jack pine and Scotch pine and balsam fir, with a few other species intended mainly for ornamental purposes. About fifteen acres are being added to the nursery this year and in 1921 it is expected that the company will be able to obtain from it two million transplants and from then on to plant out each year at least that number; nearly twice as many trees as are removed to feed the pulp mills at Grand Mere. It is not unlikely that other companies will co-operate with the Laurentide Company in this work, so that in a few years the Proulx nursery will play an even more important part in reforestation in Quebec.

Such a policy is a complete reversal of the old plan of making galley-slaves of posterity. Men now living can hardly hope to harvest the trees that they plant. The whole embodies a principle that merits adoption by everyone who is developing our natural resources, for such resources are not only *ours*, but they are the property of the future as well. When that is realized, posterity will have greater reason for pride in and gratitude toward its forebears and, if necessary, will pay some of their little bills with better grace and fewer grimaces.

### PULPWOOD AREAS DISCOVERED BY AIRPLANE

A recent despatch from Curling, Newfoundland, states that cruising in airplanes over Labrador disclosed great timber lands, from which millions of cords of pulp wood could be cut and rolled to streams for direct shipment. This information was given out by members of a Boston expedition which spent a month in Labrador and which landed at Curling from the steamer Grenville on the return journey. The

head of the expedition was Captain Daniel Owen, R.A.F.

The expedition, which included in its equipment three airplanes, and comprises a personnel of twenty persons, among them five aviators, operated seventy miles north of Battle Harbor. Two million acres of timber land was explored by air and by the ordinary methods of timber cruising. Picture staken from the air were said to show dense growths of pulp material in such manner that the most available places could be located readily. This use of the airplane was looked upon as opening a new field for commercial aviation. The planes cruised inland for more than 100 miles, flying at heights of 2,000 to 9,000 feet.

### ROADSIDE TREES

#### Some Aspects of the Subject

##### *Their advantages—*

As memorials to our soldiers and sailors.

As making our highways and byways beautiful.

As furnishing shade and preventing dust.

As improving certain kinds of roads.

As preventing growth of roadside weeds.

As producing food for man, beast, and bird.

##### *How to secure them—*

Reserving and protecting trees both young and old already growing.

Planting young trees.

##### *Where to secure them—*

From the fields or woods.

From reliable nurseries.

##### *Desirable and undesirable kinds—*

Desirable: Long-lived, beautiful trees, such as oaks, elms, ashes and hard maples.

Undesirable: Short-lived, quick-growing trees, such as cottonwoods or soft maples.

The newspapers of the United States consume 2,000,000 tons of newsprint every year, of which Canada supplies, approximately, one-fourth.

The total annual output of the Canadian pulp and paper industry exceeds in value \$85,000,000. It gives employment to 25,000 individuals. Its annual payroll exceeds \$15,000,000. It has sent more than 3,000 men to the war.



## FIRE PROTECTION ON CROWN LANDS

*Address by Mr. D. Roy Cameron, District Inspector of Dominion Forest Reserves in British Columbia, before the Western Forestry and Conservation Association, Portland, Oregon, Oct. 6, 1919.*

### How the Dominion Forestry Branch Organizes to Meet the Fire Hazard—The Results

In addressing an audience of this kind it might be pertinent to explain at the outset what is meant by the term "crown lands."

In the British Empire all unalienated lands are legally considered as being the property of His Majesty the King. In the case of self-governing peoples within the Empire such lands are designated as being lands of His Majesty in the right of the Dominion, Commonwealth, Province, or State as the case may be, and of course the administration and disposition of such lands are entirely under the jurisdiction of the governments concerned.

In the Dominion of Canada we have provinces which own their own lands, and public land provinces in which the Federal government controls the lands; similar to conditions extant as between private and public land states in this country.

The Dominion Forest Service, with which I am connected, deals with the administration and protection of timber on lands in the right of the Dominion of Canada. The province of British Columbia owns its own lands, but, as a result of the carrying out of one of the terms of Confederation, the province deeded certain lands to the Dominion including a strip twenty miles on each side of the Canadian Pacific Railway known as the Railway Belt, which area comprises the country under my jurisdiction. This strip, containing some eleven million acres, is in reality a section right across the province. It contains representative areas of practically all the timber conditions to be found on the northern Pacific slope, including the heavy rain forests of the coast proper, the yellow pine, semi-arid region east of the Coast range, and the secondary rain forests of the eastern ranges, where cedar, hemlock, spruce, and white pine are the principal commercial species. Being the area first settled, due to its relation to the pioneer railway line, it holds the densest population and consequently has perhaps the highest fire risk in the province.

Being practical-minded men, I presume you will be more interested in a statement of what has been accomplished and what remains to be done to insure adequate forest protection, than in a mere statement of the organization of our service. However, in order that you may have some idea of the nature of our activities it is necessary that I should say a few words with reference to our organization and the status of the lands with which we have to deal.

#### CANADIAN TIMBER LANDS NOT ALIENATED.

In the first place the timber lands under Dominion control, and the same may be said of provincial lands, have not been alienated on disposal of the timber thereon, as has been so frequently the policy in the United States.

The Dominion procedure has been to issue renewable licenses to cut timber on which the licensee pays a yearly ground rent and a royalty per thousand at the time of cutting. On this basis you will see the government retains a direct financial interest in all uncut timber to the amount of the royalty collectable. For this reason the protection of timber lands has remained a governmental function, so that we have not the development of private timber protective associations found here. Indeed on Dominion lands, with which alone this paper deals, the government assumes full responsibility and levies an annual charge of half the cost of protection against the timber licensee based on the proportion of his holdings to the total area protected.

Naturally only the more valuable stands of accessible merchantable timber have been taken up under license, approximating 11.5 per cent of the total area of forest lands. On the remainder the timber is still the property of the Crown.

Of the total area of unalienated lands in the Railway Belt approximately 1,760,000 acres or 18 per cent have been set aside as permanent forest reserves similar to the national forests of the United States, and some 720,000 acres or 7.4 per cent in addition are established

as Dominion National Parks. These last are not under the jurisdiction of the Dominion Forest Service.

BASIS OF ORGANIZATION.

The legal basis of our administration is, so far as forest reserves are concerned, a Dominion Forest Reserve statute, and regulations established thereunder: Outside of reserves, Dominion forest officers enforce the British Columbia Forest Act. Under an arrangement made with the provincial government the Dominion service has taken over the responsibility of fire protection on alienated lands within the Railway Belt, and our men issue the brush-burning permits required by the Provincial Act under special *ex-officio* appointments as provincial fire wardens. The only exception to this is in the case of certain long-settled areas in the lower Fraser Valley, where exemptions from permits have been granted.

In conformity with the status of the lands protected the Dominion Forest Service is separated into two main divisions, namely a forest reserve organization, similar in plan and functions to the United States Forest Service, and a fire ranging organization which, as I have said before, replaces the private protective organizations found in this country. Distinct field organizations have been built up in each of the public land provinces, but the general supervision of both is united in the office of a District Forest Inspector in each province. In addition an inspection service is carried on of railway patrols conducted by the railways themselves under the orders of the Board of Railway Commissioners, and the District Forest Inspectors are appointed officers of the Railway Board with wide powers, for this purpose.

QUANTITY AND CHARACTER OF TIMBER

The total stand of timber in the Railway Belt is estimated by the Canadian Commission of Conservation to be approximately twenty-one and a half billion feet. The important commercial species follow in the order of their occurrence:

|                              |    |           |
|------------------------------|----|-----------|
| Douglas fir                  | 31 | per cent. |
| Red cedar                    | 26 | " "       |
| Western hemlock              | 14 | " "       |
| Spruce (Englemann and Sitka) | 13 | " "       |
| Yellow pine                  | 5  | " "       |
| Balsam (several species)     | 4  | " "       |
| Lodgepole pine               | 3  | " "       |
| Western white pine           | 2  | " "       |

Owing to the proximity to settlement and transportation the forests in the Railway Belt are particularly valuable in view of their strategic position with regard to the further development of the timber industry in British Columbia. The Dominion Forest Service realizes the responsibility laid upon us to see that all possible protection is given these resources.

These then are the conditions under which we operate. What then of our record? Systematic fire protection was inaugurated in 1912 when the first forest service office was opened. We did not get into our stride before 1914 and subsequently have carried on under the double impediment of decreased allotments and absence of practically the entire supervisory and a considerable percentage of the field staff overseas. Six of our men made the supreme sacrifice for liberty and justice.

THE FIRE RECORD.

For the five years, 1914 to 1918 inclusive, the average number of fires reported was 375 with average percentage of causes as follows:

|                             |      |           |
|-----------------------------|------|-----------|
| Unknown                     | 27.5 | per cent. |
| Campers                     | 20.0 | " "       |
| Lightning                   | 12.0 | " "       |
| Railways                    | 12.0 | " "       |
| Settlers burning            | 11.5 | " "       |
| Saw-mills logging           | 6.5  | " "       |
| Incendiary                  | 3.0  | " "       |
| Careless smokers            | 3.0  | " "       |
| From U. S. A.               | 2.0  | " "       |
| Miscellaneous, known causes |      |           |
| under 1 per cent each       | 2.5  | " "       |
|                             | 100  | " "       |

The average proportion of large to small fires was 17.5 per cent.

The occurrence of these fires gives an index of the nature of the fire hazard in a normal season. The average is as follows:

|           |     |           |
|-----------|-----|-----------|
| April     | 2   | per cent. |
| May       | 16  | " "       |
| June      | 13  | " "       |
| July      | 23  | " "       |
| August    | 24  | " "       |
| September | 19  | " "       |
| October   | 3   | " "       |
|           | 100 | " "       |

The May fires usually come early in the month during a period of warm dry weather which is generally followed by intermittent rains until about July first. The ensuing summer heat, normally unbroken by rains of any conse-

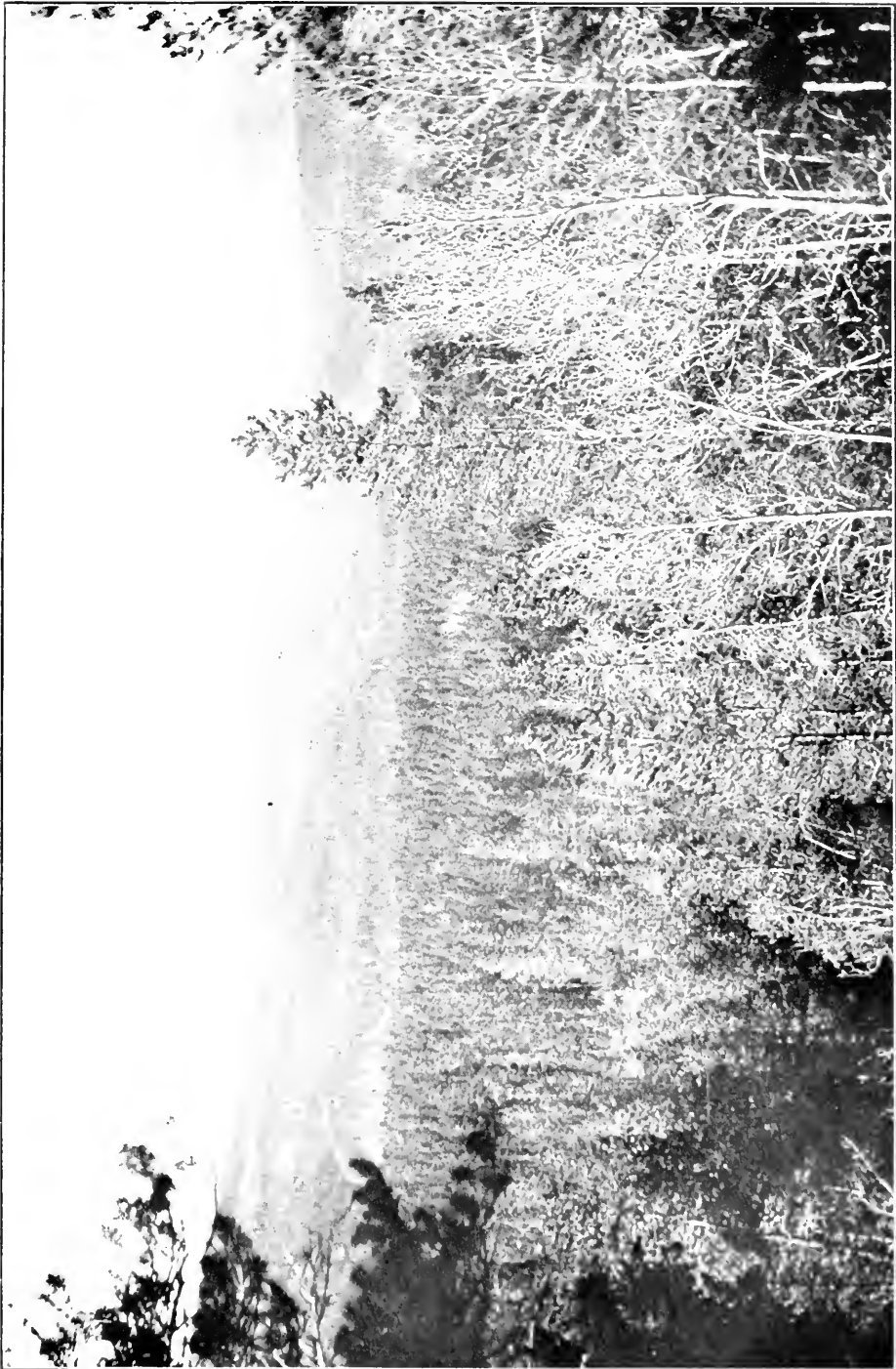

What the lookout man sees from his tower, Lodgepole Pine forest, Western Canada.

quence, induces a cumulative hazard which increases in intensity until early September when early fall rains may be expected. These are followed by another dry period, but the danger is decreased by longer nights, greater humidity and lower average temperatures. Considering the Railway Belt as a whole the fire season terminates usually more through decreased temperature and increased atmospheric humidity than by reason of heavy rains.

The total area burned over during the five year period amounted to 133,344 acres, or an average of 26,670 acres per year, which works out at approximately one-quarter of one per cent of the total area patrolled. Of this area an average of 4,360 acres was merchantable timber, loss of which has averaged approximately twenty million feet B.M. per year, or one-tenth of one per cent of the standing timber. Young growth has also been destroyed at the rate of approximately 10,000 acres per year. The remainder of the burned area has been in slashings, old burns, grass land, etc. Loss of private property has averaged something over \$10,000 per year.

To obtain these results we have spent on patrol work an average of \$64,000 per year which works out at .64 cents (sixty-four one hundredths of a cent) per acre. Improvements have cost \$15,900 per year or .16 cents (sixteen one hundredths of a cent) per acre, so that the total expenditure has averaged eight-tenths of one cent per acre per year.

The average area of the district patrolled by one man is, in forest reserves, 88,000 acres, and in the fire ranging organization 107,000 acres.

#### FIRE FIGHTING EQUIPMENT.

These figures are in proportion to the degree of protection afforded all around which is about 25 per cent more intensive on forest reserves than outside. On the reserves our protection plant is nearing completion. It includes ranger headquarter buildings, cabins, tool caches, roads, trails, telephone lines, and lookout stations. Of the latter, two are equipped with Osborne Fire Finders, the success of which is marked. As soon as maps of sufficient accuracy can be secured the remaining stations will be supplied with this instrument. Our plans call for three additional lookouts which will complete the detection system for our present reserve area.

These lookouts naturally serve the fire ranging districts outside the reserves as well and owing to the fortunate presence of a very complete

system of rural telephone lines also owned by the Dominion Government, they are of extreme value. Even at the present time our detection system is on a more efficient basis than our suppression, which needs additional personnel and further organization.

We believe in a national forest policy as the best means to secure adequate protection and proper administration of our forest resources on a permanent basis. Our policy aims at development based on the continuous extension of the areas under national forest, until practically all of the absolute forest land in the Railway Belt is included. The fire-ranging organization is properly considered as a temporary stage in the development of forest policy, holding the line until public opinion, which it serves to help awaken, will back the forest service demands for further permanent reservations. The fire-ranging organization is also a useful preliminary training ground for developing the personnel which extensions in national forests will require. In this connection I might state that we have specialized to a very large extent on returned soldiers in accordance with our general Canadian policy that they shall be given preference in Government appointments. Through an arrangement made with the Department of Soldiers' Civil Re-establishment, a forest ranger course has been established in Vancouver, a majority of the graduates of which have entered our service. Their records have been gratifyingly satisfactory, due, in large measure, to the valuable nature of the services given by their instructor, Mr. E. J. Hanzlik, Forest Examiner of the United States Forest Service at Seattle.

#### THE 1919 SITUATION.

Now, as to the 1919 situation which I have not discussed thus far. In the first place I must admit that our records at the time of writing are not compiled sufficiently to give a satisfactory summary. This is due to the fact that our worst troubles were concentrated in an area about fifty miles wide in the region of the Shuswap lakes all within one fire ranging district, where the expenditure on fire fighting will run close to \$50,000. Every ranger has had a series of fires to contend with all burning at the same time, and proper reports have not yet been received. This locality was practically without rain from June until August 31st, during which period, in addition, temperatures were above normal and dry lightning storms were frequent. One such storm caused twenty-six

separate fires, largely in timber. Also, most unfortunately, high winds at night were prevalent, so that the increased humidity usually encountered was lacking and fires progressed steadily night as well as day. As a result conditions got out of control for a time and con-

siderable destruction ensued. Elsewhere, despite adverse weather conditions, the situation was kept well in hand although we were forced to spend money freely. Altogether our fire fighting expenditure will probably exceed \$64,000.

## THE RETURNED SOLDIER AND FOREST JOBS

By *Raphael Zon, U. S. Forest Service.*



### Transient Life of Timber Areas Under Ordinary Exploitation Creates Transient Towns and Homeless Workers



The right development of our vast natural resources offers a field of opportunity to the returning soldier. In the past the use of our natural resources has failed even more than land settlement to develop permanent and contented communities. The mining camp, the lumber camp, and the construction camp, with their shifting population, are typical of the transitory character of the industries themselves. There is no more familiar sight in the region of our greatest development of natural resources than the "blanket stiff" going from camp to camp seeking a better job. The opportunities of the future, both for the returning soldier and for the people who live in the regions where there are great natural resources awaiting development, lie in the establishment of permanent industries and permanent communities. In mining operations, permanent communities providing healthful living conditions could be established because the life of the mines extends, as a rule, over a long number of years. This is particularly true where mining is carried on in the neighborhood of agricultural lands. In the case of the forest, which is a renewable resource, it is perfectly feasible to create healthy and permanent towns if the lumber industry itself is stabilized.

The lumber industry as it is at present constituted offers small opportunity for permanent and contented communities. It has passed over this country from ocean to ocean in a series of waves. It originated in Maine, moved to Michigan in the seventies, completed its highest development in the Lake states in the nineties, and is now flourishing in the southeast. There

it will be exhausted in a few decades and will then centre on the Pacific coast. As a rule it has not left permanent communities in its wake, unless the land was exceptionally suited to agriculture. The industry has been, and still is, conducted as a type of mining. A valley or logging unit is worked out; then the operation shifts to another location. In this way one valley after another has been cleared of timber and left empty and desolate. One region after another has been depleted of its forest stock.

Timber mining, being essentially migratory, breeds migratory tramp labor. Since the lumberjack must live in a camp and the man with a family is excluded as a worker, the lumber industry is an industry of homeless men. The conditions which are produced by the present methods of timber mining are well summarized in the report of the President's Mediation Commission:

The forests and lumber mills of the Pacific Northwest have a predominant war importance. The raw materials they furnish are indispensable to the execution of the aircraft and shipping programmes of the government. The entire industry employs about 70,000 men. The labor conditions in the lumber industry have their reflex upon all industry in that territory.

Social conditions have been allowed to grow up full of danger to the country. It is in these unhealthy social conditions that we find the explanation for the unrest long gathering force but now sharply brought to our



A big aid in forest protection. Corduroy road across a muskeg.

attention by its disastrous effect upon war industries.

Partly the rough pioneer character of the industry, but largely the failure to create a healthy social environment, has resulted in the migratory, drifting character of the workers. Ninety per cent of those in the camps are described by one of the wisest students of the problem, not too inaccurately, as "womanless, voteless, and jobless." The fact is that about 90 per cent of them are unmarried. Their work is most intermittent, the annual labor turnover reaching the extraordinary figure of over 600 per cent. There has been a failure to make these camps communities. It is not to be wondered, then, that in too many of these workers the instinct of workmanship is impaired. They are—or rather have been made—disintegrating forces in society.

The Commission found that the life of the average camp did not exceed three and one-half years. With migratory forest industry it is financially impossible to construct residences for workers, because the annual depreciation charges of 25 per cent or more would be far beyond the ability of the worker to pay from wages. On a \$1,600 home the annual charge would be \$400 for depreciation, and average of about \$50 for interest and perhaps \$50 for

maintenance, a total of \$500 per annum. This means a monthly rental charge of between \$40 and \$50, which is far beyond the reach of the unskilled worker as he is now paid. With the continuous operation extending 25 years or more, depreciation on such a residence would be reduced to about \$64 per annum, and since maintenance and interest would not be much affected, the annual charges would be only \$164, or less than \$14 per month.

#### THE IDEA OF PERPETUATION.

These unsatisfactory conditions in the industry can be rectified by transforming it from an industry which uses the forest as a mine to one which treats it as a renewable resource. Such a transformation is difficult on private lands. A few private owners may be found now ready to change their method of handling their timber resources and thus provide opportunities for permanent communities. As a rule, however, such a transformation will not take place without the people first securing control of the large timber holdings. For the purpose of providing for the returned soldier we must, therefore, look to the national forests. These afford immediately opportunities for creating permanent forest communities in connection with logging operations on them. Assuming that only two-thirds of the forest area within the national forests, or 100 million acres, is actually forest-bearing land, this area, when

fully developed could, at a conservative estimate, support a permanent population of 300,000 families, allowing each family \$800 a year in wages, or about 1,200,000 persons in all.

The management of forest resources on a permanent basis is even less of an experiment than rural development with government aid. In Europe sustained production of the forest forms the backbone of an economic system of small holdings, especially when dealing with poor agricultural land. In Switzerland a forest of 10,000 acres with an adjoining area of 3,000 acres of agricultural land supports a prosperous permanent community of 1,500 people. About 81 per cent of all the workmen employed in the woods and mills in Europe are small holders of land within or adjacent to the forest. The parishes of La Teste and Caseaux in the southwestern part of France in the Landes, which have been reforested for the last sixty years, contained before reforestation a population of 1,600 people. Since the forests were established these parishes support a population of 14,000.

There are now about 12,000 lumberjacks composing the tenth and twentieth Forest Regiments. There must be also a large number of lumbermen in the general draft furnished by the lumber industry. These men, when they return to civil life, will naturally look for work

in the woods and, having learned in France the benefits derived from the stability of the forest industry, will expect similar practice here.

The task of organizing our national forests into small units on a strictly continuous yield basis is not as difficult as it may seem and is not beyond the strength of the existing organization in the Forest Service. It does not mean tackling the regulation of 100,000,000 acres of forest at once, but organizing here an area and there an area as the ever-widening circles of economic life come into contact with them. Intensive forest surveys are ahead of, rather than behind, present needs. The objection that the national forests do not always control sufficiently large units for sustained management should not present an insurmountable obstacle because co-operation of the public and private owners in the management of natural producing units can be secured in most cases on a basis satisfactory to both. The further objection that the lumber industry is overdeveloped and it would be economically unsound for the government to undertake the construction of new sawmills is not valid. The overdevelopment of the lumber industry does not prevent the constant appearance of new sawmills, often operating in government timber. In many cases government control of private logging operations on the national forests would be all that would be needed, the government merely pro-



Always on the job. Ranger's house in the centre of a western reserve.

viding ahead a series of cuttings within definite periods and locations, and enforcing measures essential to the maintenance of permanent communities. The logging and milling operations can be carried out as at present under timber-sales contracts.

Lumber companies which operate on a large scale naturally are interested especially in the distant national or even international markets and, as a rule, pay little attention to the local needs. That this policy works to the disadvantage of local development is shown by the experience of many co-operative agricultural organizations, fruit and orange-growing associations, etc., which, although surrounded by public and private forests, find it difficult to secure box material for packing purposes except at very high prices. The government would be able to ameliorate this condition.

The railroads of the country now under government control are using in the neighborhood of six billion feet annually. Our army and navy also use large quantities of wood. Much of this demand could be supplied from the national forests. If the public forests can satisfy the government needs efficiently and economically, and at the same time broaden the opportunities of the people and provide conditions for permanent forest communities, it would be contrary to the national interests if they were not used for that purpose. Such use will merely serve as an illustration of how the

forests in private hands can also be handled so as to widen, instead of gradually to narrow, the opportunities of labor in the industry.

#### TOWNS THAT STICK.

The basis for each forest community would be the area within whose radius an annual cut may be permanently maintained. A sawmill suitably located within the area and continuously supplied with timber from the growth on land tributary to it would form the basis of a sawmill community which could remain permanently in one location. The logging camps which may have to change from time to time would still form a part of the entire forest community organization. The lumberjacks who are now in France engaged in logging and milling operations on government and private forests would be admirably fitted for similar logging operations on the national forests. Possibly a great deal of the logging equipment which is the property of the United States Government may be available upon the termination of the war for this purpose.

The shortage of pulp and paper in this country and the presence of a large supply of pulp timber available on the national forests opens another way for meeting the unemployment problem. The pulp industry, more than the sawmill town, provides opportunities for creating large village communities with healthful social life.

---

## LOSS OF LIFE THROUGH FOREST FIRES

---

W. M. Graham, commissioner of Indian Affairs, has received a report from the Onion Lake district, and has been informed that eight Indians were burned to death, and fifteen others injured, some of them seriously. The report indicates that the sufferers are recovering with the attention which has been given them. Supplies are being rushed to destitute Indians whose homes were destroyed by the forest fires.

The party who made the trip to Cold Lake and Onion Lake in the reports sent to the commissioner, state that the fire sprang up so suddenly that the victims had no chance for their lives, being caught in the burning inferno without a hope of getting out. The injured

managed to rush to a little lake nearby and jumped in the water to put out the fire which had already started to consume their clothes. Even in the water the flames did their deadly work, for they swept close and those unfortunates who were near the shore in shallow water had to dip under to avoid being burned. One of the Indians in the water who had been badly burned before reaching the lake nearly perished but was assisted by a young girl, who kept rolling him in the water.

Supplies have reached the sufferers and at present they are well cared for. More supplies are being sent to them, special delivery being effected by hiring farmers of the district to haul the necessities on the overland trail.





Chasing spark-throwers. Railway velocipede for following up trains.

## THE RIGHT WAY TO CUT THE FIRE LOSS

The following excerpt from a recent report by Mr. A. B. Connell, Supervisor of the Pasquia Forest Reserve in northern Saskatchewan, will be found of particular interest and significance in view of the heavy fire losses sustained during the past spring on all the neighboring forest reserves in that part of the west, and confirms the wisdom of thoroughly equipping the reserves with protective improvements so as to embody to the fullest possible extent the saving principle of prevention.

### SUMMARY REPORT, PASQUIA RESERVE, SPRING FIRE SEASON, 1919.

"The spring fire season on this reserve is now over, and it proved to be the most dangerous season since the reserve was organized. A large number of fires started at different times, but the staff succeeded in holding each fire in check and in getting it out before any material damage was done to the reserve.

"The fires started from a variety of causes, which is natural, when the country was in such a dry condition. In fact the starting of fires in such a dry season is difficult to prevent, but our experience this year has proved beyond doubt that all fires which start can be successfully handled and put out before any damage

to the reserve results, provided the organization is properly maintained. It was necessary to fight several fires at some distance from the reserve to prevent them getting out of hand and coming into the reserve, and the expense of handling all the fires was rather large. The fact that a disastrous fire was prevented however, when conditions were so unfavorable justifies the expenditure, which, after all, will be nearly covered by the revenue from the reserve for the present year.

"I have been expecting and preparing for just such a season as this ever since the fire season of 1915, when several townships in the reserve were burned owing entirely to lack of organization and preparation. This season was much more dangerous than that of 1915, and I ascribe our success in handling the situation to the following factors:

1. The improvements constructed during the past three years, particularly the Mistatim Telephone Line, which has paid for itself many times over this spring, and the lookout towers and trails. Of all the improvements the telephones proved to be by far the most useful as by their aid it was possible to get at the fires immediately.

2. The organization of the ranger staff. The proper location of the ranger headquarters and the providing of one or two assistants on each district was a great help in the handling of the fires. The greatest credit is due to all concerned for the manner in which the work was handled.

3. The equipment purchased. The rather complete equipment which has been supplied to the reserve was one of the main factors in holding the fires in check. The tools on each district were found to be entirely adequate for all demands and all of our crews were easily, completely and quickly outfitted. The motor velocipede which has been in use for four or five years and maintained in good repair proved indispensable, and particular mention should be made of the service rendered by the

gasoline pumping engine received last fall. This pumping unit proved to be invaluable and in one case saved the situation, when there was danger of both Hawkes mill and the village of Hudson Bay Junction burning.

"Finally, I have no doubt whatever but that the worst of fire seasons can be successfully handled on this reserve provided that the temporary patrol staff is greatly increased and the improvement programme is carried on from year to year as in the past. In a season such as this at least three extra patrolmen should be placed on each ranger district and used on improvement work, when the fire season is over. I believe that the fire situation would be better and much more cheaply handled by this means, i.e., by prevention, and better satisfaction obtained all around."



The portable telephone in operation. One of the greatest aids in forest protection.

### **"RECREATIONAL FORESTRY"**

Syracuse, N.Y.—A radical innovation in vocational education was announced recently by the New York State College of Forestry at Syracuse, when plans were made public for the inauguration of the first course ever given in America in recreational forestry. Students will be given technical training in the proper use of the nation's forests for camping, touring, hunting, fishing, and general recreational development. No such training has ever before been given,

but scientific use of the forests as playgrounds has come to be a demand, and New York will be the first state to offer such a course.

This announcement was made upon the return to Syracuse of Prof. Henry R. Francis, after he had completed a 10,000 mile tour of the forests of the great western states, studying the problems of recreational forestry, as a basis for formulating a course of instruction. On this tour he travelled 8,000 miles by rail, 1,200 miles by auto, and 650 miles on horseback or foot.

## THE FORESTER—A SKETCH

*An address presented at a meeting of the Sault Ste. Marie Branch of the Engineering Institute of Canada, by W. F. V. Atkinson, Forester.*

What is a forester? A forester has sometimes been called a "tree farmer" and failing a more concise description we will let it go at that. The farmer is a producer, so is the forester. The farmer produces at a low cost or he cannot subsist by his labors. To do this requires a knowledge of his work. The more knowledge he has, and the more use he can make of that knowledge in his work, the better success he is. He needs to know his soil, climate, irrigation, drainage, and fertilization, the most suitable grains, roots, and other crops including fruits and fruit trees, their various qualities, productiveness, and diseases, methods of preparing land for them and harvesting, and lastly the available markets and how to get his products to them. In all this work he has to deal with human nature, machinery, transportation, trade and its requirements. If he is an idealist he can also grow for his personal use and satisfaction some things not necessarily marketable.

The general lines are somewhat parallel to forestry, but forestry is not, as is frequently supposed, confined to aboriculture or even to silviculture. A forester though often an idealist has from his training been taught that values are the final test whether these are present or future. His whole training has been the apportioning of these values correctly, and the allotting to each subject its proper place in the scale and expressing these in dollars and cents. For the purpose of this sketch it is not necessary to go into the training and studies required by a forester at the university, but rather to deal with his general work.

The chief object of his work is to produce the woods required by trade at least cost and to continue to do so. Some of the woods now in demand were of little or no market value years ago, and some which are at present of no market value will undoubtedly be of value in the future. Thus, the history of forestry including the wood trade is essential. The first work required in the practice of his profession is to locate the various species of trees in the district placed under his charge, and to learn how these are producing wood and the conditions affecting this production. This necessitates surveys of land including topography, and of soil, and also clim-

atic records, hence, the necessity for accurate history and current records of meteorological conditions. Type maps showing the production of certain species and their inter-relationship is a second step. The accessibility of woods required to the means of transportation, such as roads, streams, and railroads, and the respective cost of each method is part of this study, as well as how to eventually harvest those trees which are not under present conditions and situation commercially available. A course in logging practice in the woods, which can only be acquired by personal experience in the actual work both in the camps and on the rivers, is necessary. If the local conditions should necessitate a change of methods when his work takes him elsewhere, his experience and training will most likely enable him after close observation to recommend improvements in road-making, tools, and camp paraphernalia generally, all tending towards the most economical methods. Thus, logging engineering is one line of a forestry training, and includes a certain class of railroad construction, steam and cable hauls in some parts of the country, road and bridge building, as well as the more primitive methods. Stream flow control and improvement, for which actual experience in river "driving" is necessary, is a further part of this work. The various methods employed in logging from the tree to the mills differ in each locality. Custom and the methods employed for many years are retained with a wonderful tenacity by the workman, and new ideas take a long time to appeal to those who are really skilled in local methods. I have seen suggestions made ineffectively time and time again and later, when adopted, become as much the logger's creed as their former methods were.

But if the administrative position is the forester's lot, he will have to leave this most fascinating part of the work for the larger idea. The engagement, control, and supplying of logging gangs is not the object of his training, but he can assist this work by tactful co-operation with the superintendents and foremen, and should know that the logging outlay is proportionate to the quantity of wood to be produced in each operation, amongst other matters, that the cost of buildings, and particularly roads



Lake Joseph, Muskoka Lakes. Grand Trunk Railway System.



Head of Fraser Lake, Central British Columbia. Grand Trunk Railway System.

and bridges, are proportionate to the required tonnage of same, both immediate and future. I believe that a great change will be made before many years in the methods of control and direction of logging operations.

Amongst the forester's first duties is to know if the demand for certain species will be regular and continuous, and whether this demand is not for such quantities and dimensions as are inimical to the best results from the available source of production, that is to say, the forest under his charge, and what percentage of loss is entailed in producing the specified timber, in the forest, in transportation, and in the manufacture. This entails inspection at all stages and places of the work.

Measurements at all points therefore are of interest and these are not only of bulk, board measure, cubic feet, cords, or otherwise, but also of the weight of the material.

If the demand is fixed as to quantity and quality and defined as to species, then from his type maps and topography, growth studies and volume tables, he can fix working plans of the areas, and for the required quantities, with regulations as to selection methods in sizes and species. The plan of a total clean-up (clear cut) is not usual in this country and thus like other drastic methods must be undertaken only when the whole forest policy is fixed, including tenure, dues, rents, taxes, interest rates, and prospective costs at all stages, etc.

If the annual demand is not greater than the area can produce under accelerated and improved growth conditions, he can fix upon rotation cuttings of the required timber; growth increment in untouched forests is not often greater than the natural losses. A rotation of cuttings under the present conditions in this country is not a fully accepted idea by the timber owners, but it is the ideal, and it is the method accepted in countries where foresters are considered a necessity. Where the cuttings must be annual, as is usual in Canada, and the production required is large, timber areas must be extremely large to establish a rotation; thus protection and assistance to the immature crop becomes an important branch of the work. In this respect drainage, light by thinnings, and protection from fire are amongst the larger issues. On these points many interesting facts which have been noted would surprise the non-technical observer.

Again, the immature crop can be augmented by judicious planting, making a greater yield per acre, and per mile of haul. This should only be done for commercial purposes where the soil is suitable and the logging inexpensive. Further, there is the method of acquiring really suitable ground for a new forest of the required species, laying it out in roads and sections for the purposes of cheap logging, and afterwards planting it with the most suitable species in point of growth rapidity of the wood required for the purposes in view. Seeding in the forest for this purpose is not sufficiently certain or rapid to be satisfactory.

The introduction and use of new kinds of wood in the different trades is another line of investigation. Our forest products laboratories have helped the forest administration very greatly in this respect. This work is also a line of specialization.

From these remarks it will be seen that forestry opens many avenues for work and study; that it aims like the farmer to produce material required for the use of man. The number of cubic feet of wood used (per capita) is increasing continually. The exact quantity, however, is hard to estimate in a country like this which exports large quantities of the manufactured products of the forest, and where waste, owing to ignorance of the rapidly diminishing supply, is so great.

The forester is continually in touch with the civil engineer, as these few remarks show, and from his work and accumulated data has also special advantages in regulating the waters in the rivers draining his districts, and which supply not only the means of transport for such woods as will float, but also supply the power where his "civil" confrere has constructed his mills or power-house. The maintenance or change of forest cover are no small factor in stream control. A great deal of the information acquired by the forest engineer should be of use to civil engineers undertaking new developments, and those will generally be found minutely and carefully charted as the use of curves for tree growth, volume tables, and other purposes is the general method. Speaking for the profession I may say that co-operation, lucidity, and professional etiquette are points on which all foresters are united.

## BIG COMPANIES TRY OUT FORESTRY METHODS



### Establish Experimental Plots to Test Local Value of Many Logging Schemes



Propaganda for the better treatment of our woodlands has always carried a prominent and noteworthy characteristic in the sympathy and co-operation of the lumbermen. The meeting of foresters and lumbermen in frank and open discussion of their problems invariably excites comment of admiration and envy from the visiting foresters from other countries. A striking characteristic has been friendly co-operation in discussion. Foresters and lumbermen have met and talked and made resolutions on the advisability of doing certain things for the benefit of the forest. They have separated to meet again next year to talk and make more resolutions. They have been doing this for thirty years and they have accomplished much in an educational way. But in reality the forests can be improved only by action in the forest, not in the office chair, not in the hotel corridor, not even at the banquet table. However, the more progressive foresters and lumbermen have realized this and so it has come to pass that theories are to be put into practice. Indeed, the only way to determine whether or not a theory will work is to try it—a self-evident fact lost sight of by other men than those interested in the welfare of the forests.

The Bathurst Lumber Company in co-operation with the New Brunswick Forest Service is carrying on experimental cuttings on 500 acres of undersized spruce on the Nipisquit river. A portion of the area is being cut under the strip system. Strips from one chain wide to three chains wide are cut clean, with strips two chains wide between, uncut or lightly culled. A portion is being cut clean in more or less circular patches of various sizes, comprising one-quarter acre to two acres in extent. Other portions are being thinned by cutting to 10, 8 and 6 inch diameter limits respectively. The slash on one-half the area of each cutting system is to be burned and on the other half unburned. The Provincial Forest Service furnishes a forest engineer who, in co-operation with Mr. Lordon, of the Bathurst Lumber Company, will carry out the plans of the cutting.

The Laurentide Company in co-operation with the Quebec Forest Service will undertake similar experimental cutting in a stand of 300 acres, mostly culled for pine only, on Cache lake, whose waters reach the St. Maurice river at Rapid Blanc. The area contains a peat bog, a merchantable black spruce swamp, balsam and spruce ridges, a merchantable stand arising from an old burn, and mature spruce and balsam in various degrees of mixture with hardwoods, so that most of the types in which logging operations are being conducted in Quebec are represented on this comparatively small area. The Logging Department and the Forestry Division of the Laurentide Company and the Provincial Forest Service will co-operate in carrying out details of the cutting.

On both areas a careful record will be made of the cost of slash burning.

The Commission of Conservation at Ottawa has the task of measuring and recording the results on each of these experimental areas. Sample acres will be laid off and the volume of wood fibre and rate of growth under the present and past conditions will be ascertained and will be used as the standard to measure the results of the various methods of cutting in terms of future growth. The investigations will include the effect of cutting to various diameter limits upon windfall, diameter increment, volume accretion, the growth of the young trees already established in the stands, and the reproduction of the commercial species after the cutting. The areas upon which the slash is burned and those upon which it is unburned will be used for a comparative study of the effects of these two conditions upon reproduction and, in co-operation with the Dominion Entomological Branch, upon the prevalence of insect diseases. These areas (burned and unburned) will also be studied in a comparative way by an expert from the standpoint of breeding ground for the various heart-rot diseases of spruce and balsam.

This work will be carried on during the logging operations and will doubtless occupy a

small investigation party during the coming summer. After that it is planned to visit the areas periodically for a number of years to measure and record results. In this way only can accurate and useable data be obtained from the experimental cuttings.

Negotiations are on the way between the Fisheries Branch at Ottawa, the Provincial Forest Service of New Brunswick, and the Commission of Conservation to establish an experiment station on 240 acres belonging to the Mirimichi Fish Hatchery at South Esk, New Brunswick. The area is badly infested by spruce budworm, and a special study will be made of this disease on the area by the Dominion Entomological Branch. The area is being cruised and plans drawn up for regulated cutting.

In this connection it might be mentioned that the Commission of Conservation and the Entomological Branch in co-operation with the respective companies have already established some 25 acres of permanent sample plots on the Laurentide Company limits at Lake Edward

and on the Riordon Pulp and Paper Company limits on Lac Tremblant, where a detailed study is being made of forest insects and fungous diseases; of the effects of the various degrees of cutting on the regeneration and growth of spruce and balsam; and particularly experiments are being inaugurated to determine the conditions for a more abundant natural reproduction of spruce after logging.

It is reported that the Riordon Pulp and Paper Company has under way plans for the establishment of an extensive experimental area, some 5,000 acres it is said, where not only different cutting methods will be tried but also experiments in broadcast seeding and in underplanting in the various conditions usually presented by logged-over and burned-over lands. Detailed and expert studies like those outlined above for the other cutting areas will be encouraged and facilities supplied for them. In fact, the plan is apparently to develop a forest experiment station where any investigator or investigative body of proved achievement may attempt to solve forest problems of economic bearing.



Forest survey party in the foothills of the Rockies.

## MUSK OX AND REINDEER INDUSTRY

A commission has been appointed to investigate the possibilities of the Canadian North as a permanent meat and wool producing area. The commission consists of Dr. J. G. Rutherford, railway commissioner, Ottawa; Messrs. J. S. McLean, manager, Harris Abattoir Company; J. B. Harkin, commissioner of Dominion Parks, and Vilhjamur Stefansson, explorer. Dr. Rutherford is appointed chairman. The commission is expected to report with the least possible delay upon the feasibility of the propositions mentioned in the memorandum which follows, together with recommendations in regard to the best methods to follow to bring about efficient development in case it is found conditions warrant action on the part of the government.

### THE MEMORANDUM.

Special attention has recently been directed to the potentialities of the Arctic and sub-Arctic regions of Canada as a grazing country. It is represented that in these regions there is an abundant growth of vegetation in the summer which forms nutritious food for grazing animals in winter as well as summer. It is estimated that there are at least a million square miles of such grazing grounds in northern Canada. The winter climate of these areas is too severe for ordinary domestic cattle, but musk ox and reindeer can graze there in the open the year round. The dimensions of the reindeer industry in Lapland and in Siberia and the great development of the reindeer herds of Alaska suggest that corresponding development can reasonably be anticipated with respect to northern Canada. In this connection it is pointed out that herds of barren land caribou aggregating, it is estimated, twenty to thirty million animals frequent northern Canada, and that biologically these animals are practically identical with reindeer.

Vilhjamur Stefansson, the Arctic explorer, is convinced that the musk ox can be readily domesticated and has urged that steps be taken in that connection with the object of developing herds for commercial purposes.

The development of large reindeer and musk ox herds in northern Canada will represent a very important addition to the meat production of the Dominion. The development of musk ox herds will represent not only an addition to the meat production, but also to the wool production. The value and attractiveness of reindeer

flesh for food purposes is well established. In regard to musk ox meat, Mr. Stefansson claims it is practically indistinguishable from beef.

In all parts of the world there is a constant reduction of grazing areas for field crops and in consequence the meat and wool problems are every year becoming more acute.

The Arctic and sub-Arctic regions of Canada lie too far north to be included in the lands suitable for the profitable cultivation of cereals and therefore may be regarded as permanent grazing areas.

In view of the foregoing the Minister considers that there are good grounds for believing that the Canadian North may become a great permanent meat and wool producing area and that a commission should be appointed for the purpose of making a thorough investigation into the subject from a business and national standpoint and to report their finding.

### DISAPPEARING FOREST WEALTH

In France and Germany there was established many years ago a system of reforestation. The law in both of these countries provided that no tree could be cut down without another being planted. Otherwise they would have long since been reduced to the condition of China with its alternations of sun-scorched plains and devastating floods.

During the war the forests of France have suffered severely, being either destroyed by the enemy or used by the French themselves for war purposes. The timber supplies of Belgium and Great Britain have also been to a large extent consumed.

All of these countries are dealing vigorously with the problem. They know that forests are an economic necessity, and are proceeding to replace the loss as fast as possible.

Unlike British Columbia, they do not propose to leave nature to do the work unaided. They doubt the efficacy of trusting to luck, without the intervention of human effort. They are putting forestry experts on the job, and giving them large sums to spend.

Which system is the better? Must British Columbia wait until its forest wealth is depleted before taking adequate measures and imitating the example of these older communities, which have already learned by experience?

—*Vancouver Sun.*



## WHAT STARTS THE FOREST FIRES ?

### Dry Weather and Dry Electrical Storms Given as the Chief Causes

Everybody knows of the great forest fires in the northwestern United States and in Western Canada. What caused these fires is a question many thousand people are asking. In a letter to *American Forestry* H. H. Rutledge, acting district forester for District No. 1, which includes the National Forest area of Northern Idaho and Montana gives what he believes to be the causes. The fires, he says, were due to a dry year, the third in succession. Lightning, railroads, campers, and brush-burning started most of the 909 discovered on this forest area in July. Lightning was given as the cause of 240 fires. Almost one-fourth were due to unknown causes, and twenty-seven were incendiary. He writes:

"This is the third dry year in succession for District 1. The snowfall last winter was far below normal, and in many locations spring precipitation was insufficient, many places having been without rain for over three months. High winds have prevailed quite generally for some sixty days and the atmosphere has been charged with electricity to such an extent that dry electrical storms have been constantly occurring. As a result the forest floor is as dry as a powder-house, and because of excessive transpiration the leaves of coniferous trees have become so combustible as to be almost explosive when subject to ignition.

"While human agencies have been responsible for some of the fires this season, lightning has been by far the most prolific source of trouble. Dry electrical storms have started a great many fires in the most inaccessible part of the forests where it has been impossible to get men and equipment on the ground quickly. In numerous cases it has required from three to six days for fire-fighters to reach a fire from the nearest railway point. And when it is remembered that equipment and supplies for the men must be transported on pack-horses over rough mountain trails and kept on the line at all times, the difficulties of the situation will be appreciated. Under these conditions it can be understood readily how lightning-set fires in these remote places become raging conflagrations before the fight against them can be begun.

"Commonly fires due to preventable causes are near lines of transportation and communication and can be discovered and suppressed before they assume serious proportions, but the reverse is true where lightning fires occur. Not infrequently in the most inaccessible mountainous regions ten, fifteen, or twenty fires are started within a few minutes by a single electrical disturbance. Sometimes these blazes are scattered over quite a large extent of territory, often they are close together, and before it is possible to start the fight against them they coalesce and form one big fire which, if the wind is blowing freshly, soon reaches the tops of the trees and develops into a crown fire that defies human efforts to combat it so long as the wind continues.

"Detailed reports on file from the several national forests of the district cover the situation only up to the close of July 30. During the night of July 31 over fifty fires were started by one severe electrical storm that ran along the westerly slopes of the Bitter Root Mountains in Idaho forests. These fires have been merely reported by wire, their extent or precise locations not yet having been determined by the field officers. They were scattered over a territory embracing roughly 4,000 square miles. Does this single night's experience convey an idea of what the Forest Service fire organization in District 1 is contending with?"

On July 30 there were approximately 3,500 fire-fighters on the line, not including rangers, lookout men, smoke-chasers, and other regularly employed forest officers, numbering about 1,500 men.

F. C. Wilfong and his crew met with a trying experience during the Selmay fire on Crooked Creek on July 24. They were trapped where three fires met, and their camp was burned. The party saved themselves by lying in the Selmay river for thirty-five minutes with wet blankets over their heads. Only one of their thirteen horses was lost, but the pack-saddles were burned from the backs of the others. Mr. Wilfong says of his experience:

"There was no way out of it; we were cornered and we plunged into the water, keeping

our faces above the surface. We put wet blankets over our heads, for the heat was so intense that our flesh would have burned if we had not taken that precaution. The roar of the flames was tremendous, but we were comparatively safe.

"Once I raised the blanket a little to peck and see how the fire was going, and what do you think I saw? There was a big bear perched

on a rock right at my feet and looking over at me as if he was ready to jump. I guess he thought I was a rock.

"We exchanged glances for a while, and I am willing to bet that he wasn't any more scared than I was, but as soon as he recovered from the surprise, he turned tail and away he went. It was the last I saw of him."

---

## NEWFOUNDLAND NEEDS A FORESTRY POLICY

---

### Forests of the Ancient Colony Being Rapidly Depleted

---

That sound ideas on the need of a reforestation policy are abroad in Canada's near neighbor, Newfoundland, are evident from the following article in the *Curling (Newfoundland) Star*:

The insatiable needs of civilization are daily devastating the surviving great forests of the world; and in some countries the timber industry is becoming a very serious one—so serious that the eyes of capitalists are being turned to other countries than their own where the forests are in a primeval state.

In Newfoundland the lumber industry has for a number of years proved a valuable adjunct to other industries, and hundreds of thousands of dollars are put in circulation to-day from an industry that was in its infancy not so many years since.

There are yet many hills and valleys, thickly wooded with heavy timber such as birch, spruce, fir, white pine, and juniper, needing every possible attention that a discerning administration can bestow upon them for their preservation.

It is very essential for the future of our forests that a forestry policy be adopted by our government; and with this object in view it is necessary that a Department of Forestry be established. No one will question such an arrangement, for it is a well known fact that our timber areas are fast becoming depleted, and little or no effort is being made to conserve them, or to have a system of afforestation carried out.

There are three ways in which the forests are being swept steadily away: the decay of

mature trees, the manufacture of lumber, and destruction by fire. There may be differences of opinion as to the best method of preventing the destruction of valuable timber by forest fires; but it will not do to settle down to a do-nothing policy, and certainly not much has yet been accomplished in either direction.

To-day the people of England and Scotland are more than ever alive to the fact that the forests of the world (particularly their own forests) are fast being used up, and are giving great attention to the question of lumber supply. They are looking to the future requirements of the state, and are giving every possible encouragement for the afforestation of lands that have become depleted of timber. So keenly alive are they, that forestry schools have been established where both men and women are being taught scientific and practical methods of afforestation at the Forestry School at Dunkeld, near where the Newfoundland Forestry Companies (Newfoundland Expeditionary Force) were operating. They are working in the nurseries, and planting trees on the estate of the Duke of Atholl, which was laid bare by the axes of our woodsmen, so that their own country may profit by the knowledge thus gained.

What is our own government going to do? Will they make some declaration as to the policy they intend to initiate and carry out, not merely for the conservation of our present timber areas, but for the afforestation of the vast stretches of country that have been depleted of its great timber wealth?

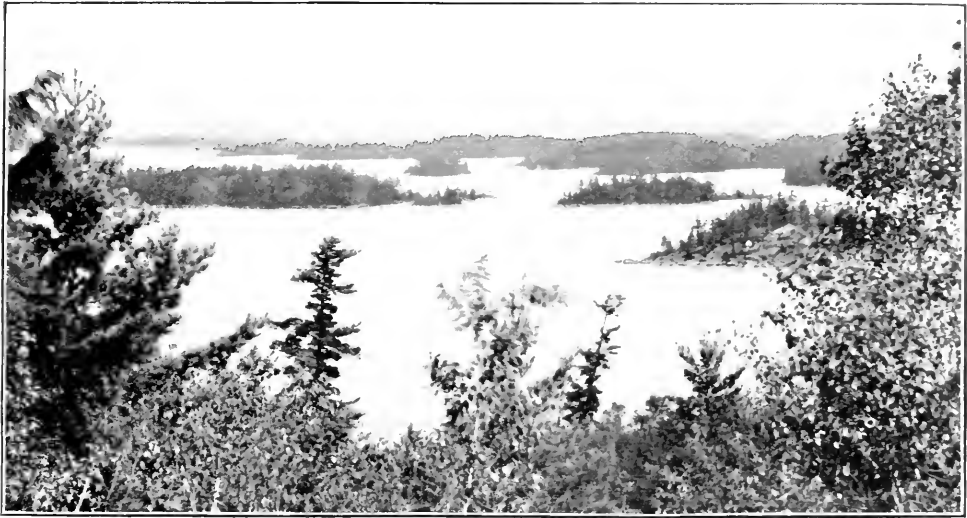

In the 30,000 Islands of the Georgian Bay. Grand Trunk Railway.

## SHADE TREE PROTECTION UNDER A COMMISSION

*By Walter D. Ludwig, District Forester, Johnstown, Penna.*

Without a doubt, one of the most potent and efficient methods of getting the average urban dweller interested in forestry principles and practices is to convert him into a shade tree enthusiast and by a proper system of educational training, hints, and suggestions, he will soon become inoculated with the virus of forestry and so an ardent advocate of the cause. Where it is not possible to carry the city man into the forest, it is possible to plant a tree in his yard or along the street in front of his home and cultivate his interest in its successful growing and care so that he will be but a few short steps away from a knowledge of trees in the aggregate and their relationships to our industrial and economic life.

Shade tree forestry then must take its place as one of the many methods of educational effort which are to be fostered and encouraged to bring about a more intimate knowledge of the care and protection of trees and their importance in the general life and actions of the people.

As a rule the condition of the average shade tree on the streets of the many cities, towns and villages is deplorable and shows an ab-

solute disregard of the proper methods of handling and caring for trees. The trees have been planted without any regard as to the proper species suitable for a certain condition, have been supposedly trimmed, but really hacked into a semblance of their former majesty and beauty by the greatest enemy of the shade tree in existence to-day, the "tree butcher" and have suffered untold but unmistakably plain evidences of ill-treatment.

The most important thing to be done is to see that careful and appropriate ordinances, by-laws and regulations are drawn up to give the necessary measure of protection to the shade trees and all the records of existing shade tree commissions should be searched thoroughly for the best features incorporated therein. Without these necessary things with which to give power to the commission, it is a waste of time and effort to take steps to create such a body.

Our ordinances in Johnstown, Pennsylvania, are rather drastic, but not more so than was indicated by the circumstances. Besides providing that written permits must be obtained for the removal, planting, or trimming of any tree in the public highway, and specifying penalties,

these ordinances contain provisions which will care for almost any contingency which may arise. And it might be added that they state specifically that "it shall be unlawful" to do so and so, and say nothing about what sort of evidence such acts shall constitute.

I should like to read these ordinances because of their value to other communities, which may be thinking of demanding a shade tree commission, but they are too lengthy for this paper, and I shall quote from only several of their more important provisions.

They provide for such injuries as may be caused by gas, hot water, steam, or other substance deleterious to tree life coming into contact with the soil around the trees, the penalty being \$50 for each tree so killed or destroyed. They specify that there must be maintained about the base of the trunk of each shade tree at least six square feet of open ground for a tree of three inches in diameter, and for every two inches of increase of such diameter, there must be an increase of at least one square foot of open ground. They make provision for injuries caused by any kind of electrically charged wire coming into contact with the branches of a tree. They provide for guards and stakes and for adequate protection from horses and animals and in the erection, and repairing of buildings in the city.

#### PERMITS ARE REQUIRED.

Nothing will so impress the people of the fact that there is some authorized body looking after the welfare and care of the shade trees as when they are asked by local officials whether they have a permit for such work as they are doing or having done to their trees. Too often the people, especially property owners, have looked upon the shade trees which they have planted in front of their own property as something with which they could do as they pleased and this old idea is hard to eradicate. Undoubtedly there are many cases where trees are trimmed without the knowledge of the local shade tree commission, but these infractions of the law become less frequent, if there is a summons to the magistrate to answer for the violation.

During the year 1918, the yearly report of the Johnstown commission shows that permits were issued for the trimming of 239 trees, killing of 9 trees, and planting of 17 trees, making a total of 85 permits for 265 trees.

As to the recognition of the supervisory work of the commission and its growth, the records

for the past spring nearly surpass by half those of the whole of the year 1918. Permits were issued so far in 1919 as follows: Trimming, 259 trees; removing, 53 trees, and planting, 78 trees, making a total of 390 trees.

#### TRIMMING 10 FEET HIGH.

Another matter which requires attention is the height of the lower branches of shade trees above the sidewalks. An open-grown tree will produce branches all along its trunk and unless systematic pruning is practiced, the lower branches will hang too low, thus preventing free passage to pedestrians, especially carrying umbrellas. To remedy this condition, the Johnstown commission has passed a resolution providing that all trees must be trimmed to a height of not less than 10 feet above the sidewalk.

#### "THE TREE BUTCHER."

The greatest enemy of the shade tree anywhere is undoubtedly the man, who takes a saw and an axe, and starts to cut and hack at the trees as though they were so much cordwood and to be disposed of as quickly as possible. Possibly there are no callings or professions in which there are so many persons engaged, who believe that they really know their business, and yet actually do not know the rudiments of such work.

Where it is at all possible, I would urge that all communities take steps to have the duly constituted authorities make a sufficient appropriation for the employment of a competent forester and shade tree expert to see that the work of the commission is carried out correctly and to the letter. I am sorry to note that we have not reached that stage in Johnstown yet, but we hope that this will be realized shortly.

In the meantime, we have issued our permits for trimming and other work, only after an investigation and report on the work done is submitted to me and the person who is to do such work has received my approval. In small communities, it is possible to get one man who will be responsible, but in the larger places, this is out of the question. After seeing the work of those who claim they are expert tree trimmers, I submit a report to the commission and they approve the work of those who qualify according to these standards. When a permit is asked for and the work is to be done by one of the accredited men on the qualified list, the secretary of the commission issues the permit.

#### TREE PLANTING.

Before any intelligent plan of planting can be adopted, it is essential that a tree census of

the community be taken. This should locate every existing shade tree, its size, species, general condition, treatment suggested, and other pertinent facts.

We have already taken such a census of several of the streets of Johnstown and these records are a permanent part of the shade tree work. The census will be extended as rapidly as possible, so that the whole city will be covered.

#### PROFESSIONAL SUPERVISION.

Probably nothing contributes to the success of the work of a shade tree commission so much as efficient professional supervision and it should be the aim of our foresters so to equip themselves by a course of study and reading that they may be in a position to render this sort of assistance. There are many pamphlets and circulars to be obtained from the various shade tree commissions and experiment stations and there are many excellent books published on the subject. With his broad knowledge of trees, supplemented by specific data as to the habits and behavior of trees under the adverse conditions of street planting, he will soon be equipped to render this service to the people.

Shade tree forestry and the ability to render assistance along this line is an important factor in general forestry work and our foresters must be prepared to meet these problems whenever they arise. By so doing, they will be furthering the efforts of the Department of Forestry to be of service to the people and to inculcate love and protection of trees, which will lead eventually to a clearer comprehension of the aims and purposes of forest.

### THE AIRPLANE IN FOREST PATROL

*By Milton R. Klepper,  
President Aero Club of Oregon.*

Late in July, outbreaks of fire in Oregon resulted in so much pressure being brought on the War Department, largely through the efforts of the Aero Club of Oregon, of which Governor Ben W. Olcott is an active member, that eight Curtiss planes were sent to Salem, Medford and Roseburg, and army flyers assigned to operate them. Two planes leave Salem each morning, one operating over the timbered area east and west of the Southern Pacific tracks as far north as Portland and the other south as far as Eugene. A similar service is maintained out of Roseburg, one of the planes covering a route

as far north as Eugene and the other as far south as Medford.

In the last few days, announcement has been made that de Haviland machines, with the Liberty motors, will be substituted for the Curtis planes, which, by their longer range of flight, will be able to cover more territory.

Whatever may be the cost of maintenance and operation of airplanes in forest fire patrol work, it can never mount to the total of the annual money loss of forest fires. The individual machine represents an outlay of several thousand dollars; keeping it in shape for continuous services takes perhaps hundreds of dollars; salaries of flyers and mechanics are high.

In comparison with these high figures for equipment and personnel of any system of airplane patrol for forest fires is the annual charge of ten million dollars to destruction of marketable timber. Last year the forest fire loss on the Pacific Coast and Inland Empire is estimated to have been six and a half million dollars.

Detection of the fires which did this damage, when the blazes were in their incipiency, would have enabled the fire-fighting forces, federal, state, and private, to have prevented a good part of this loss. A half of it, a third, would have meant more to the owners of the timber, whether private or government, than the most thorough system of airplane patrol that could be worked out.

The cost of the work which is now in operation in California and Oregon, and for the extension of which into Washington and Idaho plans are under way, has so far been borne by the Air Service of the United States Army. During its experimental stage such an arrangement can continue, but the success of the patrol foreshadows the time, soon, when the cost of the service must be paid for pro rata by the owners of the timber protected.

In the two cities in Nova Scotia, Halifax and Sydney, shade trees are only permitted to be cut down or trimmed with the consent of and under the supervision of the civic authorities. In the towns and municipalities of the province the statute forbids any person or corporation to cut or mutilate trees upon the highway without his obtaining the consent in writing of the municipality or mayor of the town, and provides a penalty for cutting or trimming trees without such consent.

# RADIO-PLANES WATCH FORESTS AND RANCHES

## Airplanes Plus the Radio Detect Fires and Supervise Farming

Airplanes, plus radio-telephone equipment, have found a brand-new peace-time utility—watching for forest fires in the vast government timber preserves, and also for supervising the operation of large ranches, such as those embracing thousands of acres and found frequently in the great western farming regions. Some of these farms and ranches are so large that it takes a superintendent all day to make an inspection trip across the ranch, even with a high-powered automobile.

The airplane as part of a farm equipment is now a reality. It makes its appearance at Hartin, Mont., on the wheat ranch owned and controlled by John Pierpont Morgan and other New York capitalists. Erhardt Schmitt, former American army aviator, has been employed to operate the machine. His duties are to carry the ranch manager from one part of the 250-mile, 100,000-acre wheat ranch to other fields. A wireless telephone in the airplane enables the manager to keep in constant communication with the ranch headquarters.

Not only can the manager or superintendent immediately report back to the ranch headquarters, by radio-telephone, but he can give local orders to gang or section foremen by means of small radio receiving stations erected about the ranch. The installation and maintenance cost of these stations is relatively small in any case. They have also been so greatly simplified during the war that practically anyone can be instructed in handling the talking and receiving apparatus in a short time. Some of these sets work as simply as the ordinary telephone.

### AIRPLANES AND RADIO SERVE TO PROTECT NATION'S FORESTS.

Recently the use of airplanes to patrol the forests and watch for incipient forest fires was extended by the government and now the wireless telephone has been installed for an experimental trial. If found to be practicable the wireless will be extended to cover the great woods with an invisible net of communication.

The wireless is expected to be an improvement upon wires or cables for one very im-

portant reason. In the past great difficulty has been experienced in maintaining wire communication in the forests because of the interruption to the service caused by falling timber, especially in the stormy season. Snowslides have been another source of destruction to the wires. The use of wireless, of course, obviates all such difficulties.

For the purpose of the present experiment the Signal Corps of the army has lent to the Forest Service four combination sets of transmitting and receiving apparatus. One set of the equipment is to be installed on Mount Hood at an elevation of about 13,000 feet, and another at the nearest forest ranger station, about twelve miles away. Two other sets are to be placed in the Clearwater Forest region of Idaho, which is a very heavy wilderness country.

All of the wireless stations will be established at look-out points, where watch is kept for forest fires, and will supplement the regular service, which not so long ago was augmented by the addition of airplanes for patrol. Now two additional airplane routes for that purpose have been mapped out, both operated from Mather Field, near Sacramento, Cal. The other two routes of the airplane service are operated from March Field, near Riverside, Cal.

The first route from Mather Field will cover the northern parts of the Eldorado and Tahoe forests on the valley side of the Sierras. The planes will start from Mather Field each morning and proceed to Oroville by way of Placerville, Colfax, Nevada City, and Strawberry Valley. A landing will be made at Oroville, where a suitable field has been provided. The return trip will be made in the afternoon.

The second route from Mather Field will cover the southern parts of the Eldorado and Stanislaus forests. Starting from Mather Field, the route runs to Placerville, Grizzly Flat, Big Trees, and to a landing near Sonora and Tuolumme. In this case also the return trip will be made in the afternoon. Each of the Mather Field routes has a round-trip length of about 150 miles.

Forest Service reports tell of a successful trial patrol undertaken recently under test conditions. No difficulty was experienced in detecting fires in heavy timber at elevations of from 6,000 to 10,000 feet.

Peculiar interest attaches to the movement for conservation as affecting North Carolina, Tennessee and Kentucky, because of the potentialities involved.—*Electrical Experimenter.*

## DRINKING WATER AND TREE PLANTING

(A Letter in the *Globe, Toronto.*)

In a recent paper you very wisely advocate the reforestation of our lands which have been denuded of trees, by communities undertaking the work, as in Germany. Let me give you one instance of what was done by a private landowner in North Wales. After the demobilization of the British army which succeeded the battle of Waterloo, Sir Robert Vaughan of Narmann Dalgetty, put the discharged soldiers of his regiment to plant a steep hillside with larch. This great wood, which lay near the popular watering place of Barmouth, was well known till thirty years ago by travellers on the Cambrian Railway. In the centre of it he had planted the date of the planting, 1818, in dark figures, so that it was visible for miles. His descendant felled the trees about 1890 and reaped an abundant harvest. One of the frequent travellers on that line was Mr. D. Lloyd George, and he must have had the forest in mind when he obtained from the British Parliament a grant for replanting of waste lands some years ago.

Now there is a magnificent opportunity to employ our discharged soldiers in the same way, which will serve two purposes. The county of Grey has a magnificent terrace of a million acres about seventeen hundred feet above the sea. It is the source of all the great rivers of Western Ontario. The snows are driven in from Lake Huron and in recent years lay to a depth of twenty feet in the magnificent forests of elm, tamarac, pine, maple, etc., which covered those lands fifty years ago. In the adjoining county, near Maple Valley, I remember magnificent maple trees of fifty feet and upwards in height, which still remained twenty-five years since as relics of the forest primeval. Now the forest is all gone, the rivers are drying up and the soil is being washed away, because the snows are swept over the summit, and suddenly melted in disastrous floods, instead of being retained long enough to fill that magnificent natural reservoir, the Artemisia gravel bed, which starts in the centre of Grey county and sends one spur down to Brantford. This

gravel bed is the chief source of the Grand River, and supplies all its feeders and springs with water all through our torrid summer, but it is being robbed at the source of the pure water which should save us from our scourge of periodic deadly epidemics due to our sewage-tainted supplies of river water served out to the cities of the Grand River Valley by the consent of the Provincial Health Board.

Now the Province of Ontario is the community which should tackle the job of replanting the forests of County Grey at once by making a provincial park on the Blue Mountains, at the source of the Grand, the Mad River, the Beaver, the Sydenham, the Saugeen and the Rocky Saugeen. The Thames is also fed from the same source.

Give the returned soldiers work by planting an enduring monument to our great victory, like Sir Robert Vaughan did in Wales a century ago.

As an illustration of what might be done we have in Brantford a magnificent elm planted on his homestead about 1830 by our pioneer, Mr. John A. Wilkes. It is 10 feet 6 inches in girth four feet from the ground, and fifty feet high. It runs twenty feet up without a limb. Near there, on the site of the old Congregational church, is a maple which exceeds 9 feet in girth, probably planted by the same gentleman after the church was built in 1836. If replanting were to become the fashion tree lovers like Mr. Wilkes would repair the slaughter of the last century by covering Ontario with woods and forests wherever waste lands, corners and steep hill-sides cry out for them. We of this generation have no right to foul rivers and streams with sewage or to leave deserts and swamps to our children to breed malaria as the Turks have blighted Mesopotamia and other lands, but we are doing just that like careless spendthrifts or decadent nations in the east.

John Robertson.

Brantford, Ont.

## CHINESE TREES GROWN IN CANADA

By A. Cosens in *Toronto Globe*.

Many of the trees, grown in this city for shade or ornament, have been imported from other countries. The European maples, the Norway and Sycamore, border our streets more frequently than do the native species. The Horse-chestnut from Greece and the Lombardy or Steeple Poplar from far Afghanistan are among the commonest of our ornamental trees. Clumps of Austrian Pine and of Norway Spruce are often planted as wind-breaks or for decorative purposes. In old-fashioned gardens and in cemeteries the Asiatic Weeping Willow was in the past a favorite tree for cultivation.

Among the aliens that have found homes in this country are two from China. The anomalies associated with that country are sufficient alone to arouse curiosity concerning these foreigners, but apart from their origin the trees themselves are interesting.

### THE MAIDEN-HAIR TREE.

The Ginkgo or Maiden-hair trees were first cultivated by Buddhist and Taouist priests, who found them growing wild in the mountains of Western China, and planted them in the Chinese temples. This was done so universally that it is apparent the trees were not introduced solely for decorative purposes, but because of some religious significance attached to them by the priests. Whatever this original stimulus may have been it has proven powerful enough to inaugurate an extensive cultivation of the trees in a country where every available foot of land is of necessity utilized.

Japanese priests brought the trees from China into their own country and planted them in the vicinity of their temples and shrines. In that country the wealthier class are now using them as ornamental trees. From Japan specimens were imported into England, where they found a home in Kew Gardens. The first Ginkgo was introduced into this continent in the year 1784 by Alexander Hamilton. As well as in the southern part of Ontario, the tree is grown successfully in the Eastern States as far north as Eastern Massachusetts and Central Michigan.

### BEAUTIFUL FOLIAGE.

The Maiden-hair tree is a very appropriate name for the Ginkgo, as it has the wedge-shaped leaves and the typically forking veins of the Maiden-hair fern. Like this fern, the tree has

a beauty of foliage peculiarly its own. The leaves, unfolding in the spring, soon assume a deep, lustrous green hue, which is retained by them throughout the summer. Even in autumn they are still attractive, but the color scheme is quite different. At that season the green of the leaves is changed uniformly to a bright, pleasing yellow.

After the fall of the leaves, the tapering top and vertical position of the upper branches become more apparent, and give the tree a close resemblance to the common introduced Poplar, the Steeple or Lombardy. It is, however, much nearer akin to the cone-bearing trees, the spruces and pines of our Canadian woods, but of a nobler and more ancient lineage.

### OF LONG DESCENT.

The Ginkgo is now the only survivor of its race, but its ancestors, in the far past, numbered many species, and formed dense forests through the dim aisles of which roamed the gigantic land reptiles of that age. Its fern-like leaves indicate a relationship to even a more remote type of flora, the beautiful fern allies of the coal period, and continue the hereditary line of the tree back almost to the dawn of plant life.

The Ginkgos resemble many of our native trees and shrubs in having the two sexes represented among them. It is usually the male trees that are planted for shade or ornament, as the plum-like fruit of the female tree has a disagreeable odor. In spite of this objection to the latter, there is a well-known example of their cultivation in Washington, D.C. In that city the avenue, at the head of which stands the building of the Department of Agriculture, is bordered by them. It is only in Japan that any effort has been made to use the fruit. There the seeds of it are roasted and served at banquets as a delicacy.

### THE TREE OF HEAVEN.

The Ailanthus, or Tree of Heaven, attains, under favorable conditions, to a height of 70 feet. In comparison with our native pines and elms that often tower up over one hundred feet, this tree seems scarcely to merit its name, but in the Molucca Islands, where the word Ailanthus signifies Tree of Heaven, there may be less formidable rivals.



This Chinese tree, also, was brought to the notice of European tree-lovers by a religious sect. It was introduced into Europe about the middle of the eighteenth century by Jesuit missionaries, who believed it would serve as a suitable food for a certain species of silkworm. The purpose for which the trees were originally imported was never carried out successfully, but they soon became great favorites for ornamental purposes, and were grown extensively. Brought to the United States, they were planted at first near Philadelphia, and are now under cultivation throughout the Eastern States and parts of Canada.

#### A TROPICAL APPEARANCE.

As the flowers of the tree are inconspicuous, the beauty of its foliage is all the more striking. The leaves, often three feet in length, drooping over from the vertical branches, give to the tree a graceful and tropical appearance. The attractiveness of the leaves is further enhanced by their coloring, which is even more splendid

than that of the Ginkgo. The seasonal variations in the foliage tints of the Ailanthus are pleasing. As the many pairs of leaflets unfold from the opening buds, there is displayed an iridescence of bronzy greens, pale greens and madder browns, a gorgeousness of tinting truly oriental. When fully displayed, the leaves are vivid green in color, and their characteristic brilliancy they retain throughout the summer. In autumn, the bright, lemon-yellow color of the foliage contrasts beautifully with the deeper yellows and orange to reddish tints of the large, drooping clusters of fruit.

In addition to its beauty of foliage the Ailanthus has other characteristics that make it a favorite for cultivation. It never roots deeply, and, in consequence, is a very rapid grower. From the shallow roots off-shoots frequently spring up that can be readily transplanted. The seeds, also, provide an easy means for securing new stock, as a large percentage of them will germinate.



Indian River, Muskoka Lakes. Grand Trunk Railway System.

## REFORESTATION NOW NECESSARY

*Ellwood Wilson, Manager Forestry Branch, the Leurentide Co.,  
in Toronto Financial Post.*

### Cutting Arranged to Rotate Over Replanted Areas—Seaplanes for Surveys and Fire Protection

The man who invests in any business venture naturally wishes to know as much as possible about the various factors which make for the success of the enterprise. If he is buying bonds he wants to know that the security back of them is sufficient to reimburse him if the business fails. If he is a buyer of the stock he also wants to know what the chances are for earning the dividends which he hopes will be paid. The bond holder will look into the value of the buildings and plant, the real estate, the existence and value of good-will, if any, and everything else which might have a sale value. The stockholder is more concerned with intangibles than the bond-buyer. In addition to the physical side of the property, he wishes to know who the directors are and their character and financial standing; who the manager is; where and how large the market is for the product; where the raw materials and supplies are to come from, and what the shipping facilities are.

In both cases, however, the wise investor will be much concerned about the source and quantity and price of the raw materials which enter into the finished product. A plant which has only enough raw materials for a few years, or which has to face a continually increasing raw material cost, would not be considered a good investment. Only in the event of plans to set aside a certain amount each year for the complete amortization of the plant after a certain term of years, as in the case of a well managed gold mine, for instance, would the careful investor be satisfied to put his money into an enterprise which faced a shortage of raw material.

#### THOUGHT WOODLANDS INEXHAUSTIBLE.

The pulp and paper industry is one of the most important, perhaps from the point of view of trade balances and our exports the most important, and the person at present or prospectively interested in this business should look into the future supply of raw material, wood. In the beginning of this industry, when plants were

few and small, little thought was given to this question. We were supposed to have vast areas of timber. In the case of most mills, the supply was literally at their back-doors and they never troubled to ask about the future. In fact they operated their woodlands as though they were inexhaustible mines, except that no reserve was set aside for depletion. Explorations by trained foresters and studies of the rate of growth and yield of the different species have shown absolutely that the forests are not inexhaustible or even self-perpetuating. The fact that Canada has millions of acres of forests does not mean that we have unlimited supplies of timber. The trees may not be the kind we need, any more than a vacant lot covered with weeds is a vegetable garden; the trees we need may be so few in number on a given area or may be so difficult of access that the possession of forests of them may be of no more value than seawater, known to contain a small amount of gold, is to the gold miner, or rich coal deposits at the north pole to the coal operator. In all the countries of Europe, except Russia and Siberia, virgin forests have gradually been cut away and their place taken by planted forests or those which renew themselves under conditions controlled by man. The end of the pulpwood supply in the Eastern United States is in sight within the next fifteen years approximately, and the day when the available timber for any given mill in Canada will be used up can be predicted with reasonable accuracy.

#### PLANS TO SAVE LIMITS.

What shall be done to perpetuate our supplies within reasonable distances and costs of transportation and in sufficient quantity to keep our mills running? There is, so far as has been discovered, only one answer: so to operate our forests that not a particle of wood shall be wasted, and to begin planting operations at once. Plantations can be made on lands near enough to the mills to make fire protection much cheaper and more efficient than in the virgin forests; wastes can be eliminated; huge

storage piles which are needed for the winter months and which tie up large sums of money can be done away with, transportation and logging costs can be materially cut, and a better and more uniform quality of raw material can be produced. The cost is by no means prohibitive and the production per acre can be multiplied by eight.

The Laurentide Company, Limited, was the first Canadian company to investigate the question, and had farsightedness and courage enough to tackle the problem "man fashion," and others are following in its footsteps. A determined effort to eliminate forest fires was begun in 1908 by the formation of a special department for that purpose and when the construction of the National Transcontinental Railway was begun a co-operative association was organized to prevent fires along the right-of-way and this developed into the St. Maurice Forest Protective Association, which has so reduced the fire hazard that the loss of merchantable timber is now less than one-hundredth of one per cent.

#### USING TWO SEAPLANES.

This association is experimenting with two seaplanes, loaned by the Department of Naval Service, in the discovery and fighting of forest fires and in mapping timber limits, and the experiment so far shows that they will be of the greatest practical value.

In 1908 the first experimental plantations were made and these were continued on a small scale until 1914, when about 150,000 trees were planted. The nursery was enlarged in 1915, and each year since then, until now the number of trees for planting will reach two millions in 1921. This year one million trees were planted. It is planned to plant annually a little more than the number cut and to build up an area of approximately 400 square miles of planted timber which will be cut on a rotation of forty years, that is one-fortieth of the area will be cut each year and immediately planted; this will supply timber in perpetuity to the mill.

#### EXPERIMENTAL PLOTS.

As very little is known about the conditions of growth of the different pulpwood species on different soils, experimental plots have been laid out and planted and careful studies are being made of just what takes place. An experimental area has also been laid out in the natural forests and growth under natural conditions is also being studied. Experimental cuttings are also being made to find out the effect

of different logging methods and to improve them if possible. This latter work is being carried out under co-operation with the Commission of Conservation and the Department of Lands and Forests of Quebec, and much valuable information has already been secured.

"If we should begin to-day to protect our cut-over lands from fire and to use wholly practical methods of forestry to secure reproduction after logging, we could secure in the next 50 or 60 years an annual production of over 60,000,000,000 feet a year without lessening our forest capital. And this would be done without devoting to tree growth land that is not chiefly valuable for that purpose."—*Henry S. Graves, United States Forest Service.*

## TREES FOR MEMORIAL PLANTINGS



Special quotations on quantity lots of  
Shade Trees, Weepers, Evergreens, etc.

Send for Catalogue.

## STONE & WELLINGTON

The Fonthill Nurseries

TORONTO

ONTARIO

## REFORESTATION AS A POST-WAR POLICY

An important item of post-war policy in both France and Great Britain will unquestionably be an extensive programme of reforestation. Without the products of the planted forests of France, the prosecution of the war would have been handicapped to an extremely serious extent. It is hardly putting it too strongly to say that, had it not been for the French forests, the war could scarcely have been won—certainly not without an incomparably greater effort and much greater loss of life than has proved necessary. The limited timber supplies of the British Isles have also proved so vital a factor in connection with the home situation that plans are already being laid for a very extensive programme of reforesting waste lands at state expense or by state aid.

The economic importance to Canada of her great forest areas is no less apparent. The value of our primary forest products exported from the country during the past year totalled some \$200,000,000. The pulp and paper industry exports products valued at some \$85,000,000 annually. The importance of perpetuating a resource that assists so largely in redressing our unfavorable trade balance can scarcely be over-emphasized.

The first and most vitally necessary step toward handling our forests as crops, rather than mines, is, of course, the prevention of fires. Great progress has been made in this direction during recent years, though much still remains to be accomplished.

The next step should be the adoption and strict enforcement of improved cutting regulations in connection with all logging operations on Crown lands. The situation in this respect is least satisfactory in the province of Ontario and on Dominion licensed timber lands in the west.

Another step, toward which extensive plans should soon be made, is the reforestation of the more accessible areas of non-agricultural lands, on which the forest growth has been so completely destroyed by successive fires that regeneration of valuable species by natural means can not take place for a very long period of time, if at all. Such a policy of reforestation on Crown lands must, as a rule, be carried out by governmental agencies, on account of the long time-element involved before returns can be secured. Both Ontario and Quebec have provincial forest nurseries, from which many million young trees have been supplied to farmers and other private interests, including pulp and paper companies and, to a much smaller extent, to lumbermen. The forest revenue from Crown lands in both these provinces is so large that the annual expenditure of a moderate proportion of it on reforestation of denuded Crown lands would appear both feasible and logical. Experience indicates clearly that such a project can be made attractive from the view-point of a long-time investment.—*Conservation.*

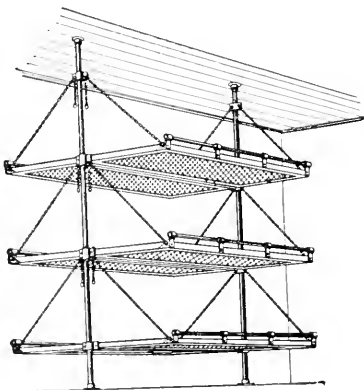

### STEEL BUNKS FOR CAMPS

Included in the well-known line of DENNISTEEL factory, hospital, camp and ship equipment is the all-steel sanitary bunk illustrated. Take up very little room, are comfortable, hygienic and practically indestructible—a permanent investment. Write for particulars and folders on any of the following lines: Steel Lockers, Bins, Cabinets, Chairs, Stools, Etc. Standardized Steel Shelving (knock-down system), Steel Hospital Equipment, General Builders' Iron-work. Ornamental Bronze, Iron and Wirework. Wirework of every description.

**THE DENNIS WIRE AND IRON  
WORKS CO. LIMITED**

**LONDON  
CANADA**

HALIFAX    MONTREAL    OTTAWA    TORONTO  
WINNIPEG    VANCOUVER

## TAX THEORIES AND GROWING TIMBER

(From *American Lumberman*.)

Readers of the *American Lumberman* probably understand pretty well the basic theory of the single tax principle, which is very simple, namely, that natural resources rather than the products of labor should bear the brunt of taxation. The single taxers would levy upon the value of land, but not at all upon the value of any buildings upon it. Their idea is to discourage land speculation, the holding of vacant property for the increase of values brought about not by the owner, but by the increase in population, and they would encourage building improvements by exempting them from taxation.

This idea has found reflection to some extent in the taxation systems in many sections; although building improvements are not entirely exempted from taxation in most such instances, they enjoy a lower rate than do the land values.

The difficulty comes in applying this theory to such natural resources as are included in the title of land. Valuable timber may often have much greater value than the land upon which it is grown and the same may often be true of mineral wealth below the surface. The proposed Ralston bill recently discussed by the *American Lumberman* would impose a Federal tax upon land in holdings above a certain size

and makes no distinction between land itself and forest or mineral resources.

Some single taxers have felt that this plan as applied to timber did not produce the results desired, but rather the reverse. The late J. J. Pastoriza, of Houston, Texas, once expressed himself to the writer as favoring some exemption or modification of single tax as applied to timber. It, however, seems to have remained for a member of the United States Forest Service to point out the very obvious fact that while annual taxation of the land is justifiable because of the fact that land is imperishable and has annual rental value such taxation whether under our present form or under an application of single tax is basically unjust as applied to resources of mine and forest which can be used but once and are consumed in the use. He insists, therefore, that there should be a single tax upon such resources, levied and collected when they are harvested. The orthodox single taxer having as his basic idea that all natural resources must be taxed, and recognizing virgin timber as a resource, has failed to make this distinction, which when once stated is very apparent. Of course, when the virgin timber is replaced by a man-grown crop this is a product of human labor, and therefore, not taxable under any interpretation of the single tax theory.

### AIRPLANE LOCATES LARGE FOREST FIRE

The Victoria, British Columbia, *Times*, of Sept. 27, has the following interesting item:

For the first time in the history of this province an airplane has been successful in detecting a forest fire and reporting the location to the fire ranger. While the airplane Pathfinder No. 2 was flying over Duncan, Pilot Brown caught sight of a large amount of smoke issuing from a densely wooded country. He immediately proceeded to the spot, and on circling overhead ascertained the extent of the blaze and the exact location. On returning to Duncan he reported the matter to the fire ranger who took steps to check and extinguish the blaze.

For some time past the Provincial Government has been asked by the Aerial League of

Canada to institute an aerial forestry patrol, but so far nothing has been done. When Pilot Brown saw the fire he decided to show how quickly a fire could be located and information given for expeditiously subduing the flames.

### HEMLOCK BARK USEFUL

The feasibility of using waste hemlock bark from paper mill operations for tanning purposes has been further demonstrated in recent tests made by the Forest Products Laboratory, Madison, Wis. The product is satisfactory to the tanner, and can be prepared at a cost that will allow it to compete with leaf bark. The use of paper mill bark for tanning would mean a source of income to the paper mill from a material which is now of little or no value.

## DYNAMITING TREES TO SAVE THEM

Central Park, New York, is losing its trees. They have been dying off by thousands. The reason is now known to be the inability of the roots to penetrate the hard clay subsoil. The trees under these circumstances grow until they are too large to thrive on what water and nutriment they can get above the subsoil, and then they will wither and die. The available soil in Central Park is two and a half to five feet deep, and trees can grow in it to a diameter of two and a half to three feet. Beyond this they need deeper rootage, and this is denied them by the impenetrable clay. This clay it is now proposed to break up with charges of dynamite, so that the roots can get through it. Blasting of this kind, according to City Forester J. S. Kaplan, has been successfully used in breaking up bed-rock for orchards, and there is no reason why it should not succeed with hard clay, as in the present instance. Says the *New York Times*:

"Park Commissioner Francis D. Gallatin announced recently that the inability of tree-roots to penetrate the hard clay subsoil had been discovered to be the real cause of the death by thousands of all species of trees in the park and that this fall an attempt would be made to save the trees by dynamiting to shatter the clay and to allow the roots to penetrate deeper.

"After a great many theories had been put forward to account for the deaths of the trees by hundreds in recent years, the real explanation, Commissioner Gallatin said, was found when a new device for pulling trees and stumps, which was evolved during the war, was used in Central Park. This invention was a stump-puller, operated by hand, which lifted the tree and the soil attached to its roots out of the ground intact. The pulling of dead trees and stumps by this method began in January. It was found that the roots extended from two and a half to five feet deep and were then stopped short by the hard clay.

"When this condition was found uniformly, as hundreds of trees were pulled during the spring and summer, City Forester J. S. Kaplan came to the conclusion that the trees were dying because their roots did not go deep enough to take in a sufficient amount of water to keep alive trees of their size, and that the droughts and frosts of the last few years had been deadly to trees whose vitality was already impaired.

"The plan adopted by Commissioner Gallatin is that of setting aside a section of the southern part of the plot of about five acres with from thirty to thirty-five trees. . . . Holes will be bored with soil-augers to a depth of from four to five feet just under the outer foliage of the trees and small charges of dynamite set off. One blast will be used for small trees and two or more for the larger ones. It will require two or three years of observation thereafter to measure the success of this plan."

## CLOTHING FROM FOREST TREES

### Several Regions of the Earth Yield Dress Material

One of the strangest of myths is that which concerns the "deadly upas tree" of Java, whose poisonous exhalations were formerly alleged to kill any man or animal that ventured into its neighborhood.

Doubtless it had its origin in some traveller's tale, for the tree in question—rather widely distributed in southern and southeastern Asia—has no terrors for the natives of those countries who, on the contrary, find it extremely useful.

It is the only kind of tree in the world that produces ready-made clothing. The inner bark is a natural cloth, only requiring the removal of the soft cellular stuff from between the woven fibres in order to render it available for use. A cylindrical section of it from a small branch will furnish a leg for a pair of trousers or an arm for a coat, while from the bigger branch the body of the garment is obtained.

In tropical South America the inner bark of another species of tree yields an excellent cloth, the fibres of which are interwoven much as if the fabric came from a loom. All that is necessary is to wash and beat out the cellular stuff from the interstices and, when dried, it is light, flexible and altogether suitable for making up into garments.

The famous "tapa" cloth of Polynesia is made from the inner bark of the paper mulberry. When of the finest quality it is bleached to snowy whiteness and fine as muslin.

In tropical Africa the inner bark of a leguminous tree is utilized in the same way. Indeed, it is surprising to learn how widely tree barks are employed as materials for clothing the world over. And in the West Indies grows the "lace-bark tree," which yields a delicate tissue so like lace that many articles of feminine adornment are made from it.

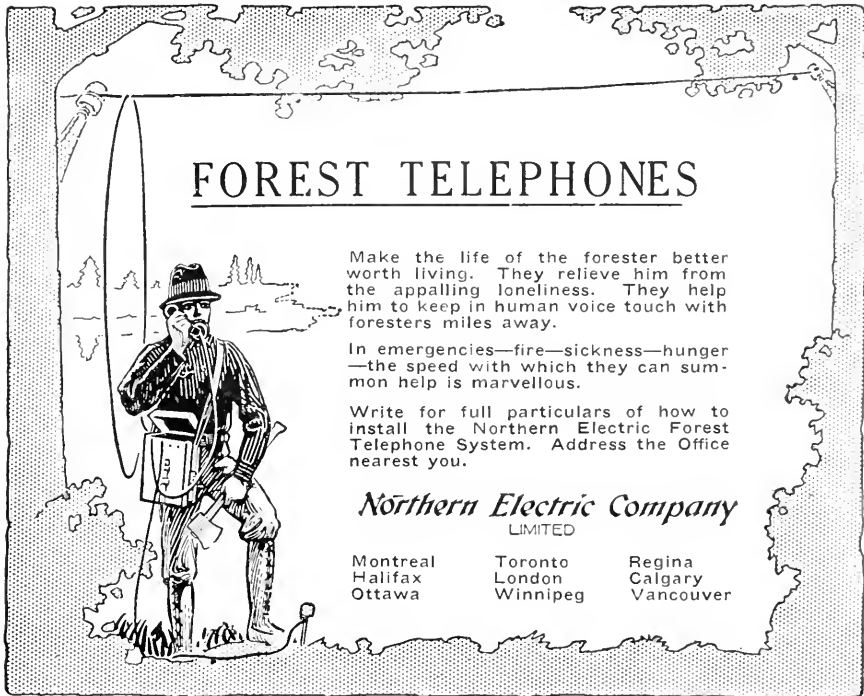

## FOREST TELEPHONES

Make the life of the forester better worth living. They relieve him from the appalling loneliness. They help him to keep in human voice touch with foresters miles away.

In emergencies—fire—sickness—hunger—the speed with which they can summon help is marvellous.

Write for full particulars of how to install the Northern Electric Forest Telephone System. Address the Office nearest you.

*Northern Electric Company*  
LIMITED

|          |          |           |
|----------|----------|-----------|
| Montreal | Toronto  | Regina    |
| Halifax  | London   | Calgary   |
| Ottawa   | Winnipeg | Vancouver |

***Northern · Electric · Forest · Telephones ·***

## Foresters' Equipment

MOSQUITO AND INSECT PROOF TENTS  
WATER AND MILDEW PROOF BAGS  
FROST PROOF SLEEPING BAGS  
ALL "WOODS" QUALITY

## Woods Manufacturing Co.

DEPT. D.

OTTAWA

**TREES, SHRUBS and SEEDS**

HARDY NORTHERN TREE STOCK

**EDYE-DE-HURST & SON, DENNYHURST**

DRYDEN, ONT.

Shippers to H.M. Government.

**Hill's Seedlings & Transplants**

ALSO Tree Seeds for Reforesting. Best for over half a century. Immense stock of leading hardy sorts at low prices. Write for price list and mention this magazine. Forest Planters Guide Free.

**The D. HILL NURSERY CO.** Evergreen Specialists  
Largest Growers in America.  
Box 503. DUNDEE, Ill., U.S.A.

**Try This Stump Puller at Our Risk**

The 3m' Stump Puller will take out every tree and stump by the roots, clearing from one to three acres a day, doing the work of twenty men. We want you to send for our 3 year guarantee against breakage and our free trial proposition. Address W. Smith Grubber Co. 11 Smith St. LaCrescent, Minn.



**GAGNON & MORISSETTE**

TIMBERLAND CRUISERS  
LUMBER CONTRACTORS  
FOREST INDUSTRIES

CHICOUTIMI, - - P.Q.

**LT.-COL. L. J. D. MARQUIS**

Forest Engineer and Mem. Can. Soc. of F.E.;  
Quebec Assoc. of F.E.; Former  
Mem. Que. F. Service

Timber Factors and Logging Costs  
Facts on Forest Growth and Future Products  
Forest Cruising and Mapping  
GIFFARD, - - - QUEBEC.

**Timber Lands Bought & Sold**  
Timber and Pulp Wood Estimates.

**R. R. BRADLEY**

CONSULTING FORESTER  
Globe-Atlantic Bldg. - ST. JOHN. N.B.

ASK FOR



**Timber Estimating & Mapping**  
Management of Forest Properties.  
Supervision of Lumbering Operations.  
Forest Planting.

**COOLIDGE & CARLISLE**  
FOREST ENGINEERS  
BANGOR - - - MAINE.

**Timber Estimates**

JAMES W. SEWALL

Old Town, Maine.





**FAIRBANKS - MORSE  
FIRE  
FIGHTING PUMP**

These outfits are replacing many men and doing work impossible by any other method.

*Send for Information.*

**THE CANADIAN  
FAIRBANKS-MORSE  
CO., LIMITED**

Offices in  
Every large  
Canadian City.

## EXHIBITION CAR TOURING NORTHERN ONTARIO

The railway exhibition car of the Canadian Forestry Association is making a decided hit all through Northern Ontario. As many as one thousand visitors a day have called to see the various displays which are attractively arranged. The car is exceptionally well fitted up for the purpose and contains a multitude of exhibits showing the manufacture of pulp and lumber. There is also a model forest nursery, model lookout towers, forest telephone equipment, a working wireless system, a maple sugar bush, as well as a nexhibit of forest insects and their depredations. A motion picture lecture is given every evening in a local hall of each place visited and deals almost exclusively with the importance of the forest industries and the need of guarding their raw materials.

—Canada Lumberman.

## FOREST SEED FOR SCOTLAND

The New Westminster *British Columbian* reports: Mr. B. R. Morton of the Dominion Forestry Branch, has been on the Coast since July taking up again the work of supplying Sitka spruce and Douglas fir seeds to the Board of Agriculture, Scotland, for much-needed reforestation purposes. Mr. Morton initiated this work at the coast in 1917.

Mr. Morton is finding it difficult to secure good spruce seeds in quantity, according to his interview with the *Pacific Coast Lumberman*. However, he proposed to extend his search to the Queen Charlotte Islands and Prince Rupert. At first Scotland had asked for red cedar seeds only, but will now take all kinds as long as they are from the coast trees, the interior trees not being suitable.

Mr. Morton is now setting up in Kamloops a seed extracting plant. It occupies a stable building, and consists simply of racks, with trays to fit  $3\frac{1}{2}$  by  $2\frac{1}{2}$  feet having screen bottoms—and a furnace. The cones are spread out on the trays, and the room is heated to 100 degrees. In from two to five hours the cones burst open—except those of the jack pine and the lodgepole pine, which require up to 24 hours of this heating. The trays are shaken every so often, causing the seeds to drop through to the floor, where they are swept up. Afterwards the burst cones are thrashed for seeds that still remain in them.



**QUEEN'S**  
**UNIVERSITY**  
KINGSTON,  
ONTARIO

**ARTS**  
Part of the Arts course may be covered by  
correspondence.

**MEDICINE      EDUCATION**  
**APPLIED SCIENCE**  
Mining, Chemical, Civil,  
Mechanical and Electrical  
Engineering

**SUMMER SCHOOL      NAVIGATION SCHOOL**  
July and August.      December to April

26      **GEO. Y. CHOWN, Registrar.**

## UNIVERSITY OF NEW BRUNSWICK

FREDERICTON, N.B.

### DEPARTMENT OF FORESTRY

Established in 1908.

Best of facilities for definite instruction and supervision in Practical Forestry.

Surveying, cruising and construction work carried on in our own tract of 3600 acres, with Forestry Camp in the centre.

Competent men from the School at present in demand to take up Forest Survey work with the Provincial Crown Land Department.

For further information address:

### DEPARTMENT OF FORESTRY

University Calendar furnished on application.

C. C. JONES, *Chancellor.*

## TABLE OF CONTENTS FOR OCTOBER, 1919

|   |     |
|---|-----|
| Canada's Forests as a Crop. By Clyde Leavitt.....         | 387 |
| Working for Posterity. By Allan Donnell.....              | 391 |
| Fire Protection on Crown Lands. By D. Roy Cameron.....    | 395 |
| The Returned Soldier and Forest Jobs. By Raphael Zon..... | 399 |
| The Right Way to Cut the Fire Loss.....                   | 403 |
| The Forester—A Sketch. By W. F. V. Atkinson.....          | 405 |
| Big Companies Try Out Forestry Methods.....               | 408 |
| Musk Ox and Reindeer Industry.....                        | 410 |
| What Starts Forest Fires.....                             | 411 |
| Newfoundland Needs a Forestry Policy.....                 | 412 |
| Shade Tree Protection. By W. D. Ludwig.....               | 413 |
| The Airplane in Forest Patrol.....                        | 415 |
| Radio Planes Watch Forests and Ranches.....               | 416 |
| Drinking Water and Tree Planting.....                     | 417 |
| Chinese Trees Grown in Canada.....                        | 418 |
| Reforestation Now Necessary. By Ellwood Wilson.....       | 420 |
| Reforestation as a Post-War Policy.....                   | 422 |
| Tax Theories and Growing Timber.....                      | 423 |

## FROM PINGARRA, WESTERN AUSTRALIA.

"Allow me to congratulate you upon the improvements effected in your excellent Forestry Journal."

A READER.

WANTED

## LIGHT RAILS

State whether complete with splice or angle bars.

Give size, quantity, location, condition and best cash price f. o. b. cars loading point.

Box No. B, Canadian Forestry Journal, Ottawa, Can.

## B. M. McGRATH

Colonial and Industrial Investments,  
Timber, Pulp Wood Areas and  
Waterpowers.

Newfoundland and Labrador  
Mines and Minerals.

*Reports, Plans and Estimates Furnished*

TRADE REVIEW BUILDING,  
ST. JOHN'S, NEWFOUNDLAND

## MOTION PICTURE MACHINES

## STEREOPTICONS

We are fully equipped to  
supply projection  
apparatus on short notice.

LANTERN SLIDES and  
Motion Picture Film made  
up in twenty hours.

Write for Catalog.

PROJECTION DEPARTMENT  
SUPPLIES COMPANY  
OF CANADA  
65 SPARKS STREET,  
OTTAWA, ONT.

# Everyone Who Bought Canada's Victory Bonds Made Money . . . . .

EVERY one of the million and a half subscribers to Canada's Victory Bonds knows that he can sell them to-day for more than he paid for them.

Every one who bought Canada's Victory Bonds has received  $5\frac{1}{2}$  per cent interest per annum—paid twice a year.

Over half a million Canadians who bought Canada's Victory Bonds on the instalment plan saved money that they would not otherwise have saved.

The guarantee back of Canada's Victory Bonds is the same as the guarantee back of a One Dollar or a Two Dollar bill. There is this difference, however, that you get interest on the Victory Bonds and you don't on the One or Two Dollar bill.

Canada's Victory Bonds will always be accepted as security for a loan.

Banks are ready to loan money on Canada's Victory Bonds.

Canada's Victory Bonds may be turned into cash at any time.

There is no other way in which you can invest your money with such absolute security—paying such a good rate of interest.

Canada will soon give her citizens an opportunity to buy Victory Bonds 1919. It will probably be the last chance to buy Canada's Victory Bonds on such favorable terms.

*Prepare to buy as many Victory Bonds this time as you  
now wish you had been able to buy the last time.*

# Victory Loan 1919

*"EVERY DOLLAR SPENT IN CANADA"*

Issued by Canada's Victory Loan Committee,  
in co-operation with the Minister of Finance  
of the Dominion of Canada.

IF YOU WANT A CHEW  
THAT WILL JUST SUIT

YOU ASK FOR

**STAG**

**CHEWING TOBACCO**

RICH AND SATISFYING.

IT IS ALSO KNOWN TO BE  
"EVER-LASTING-LY GOOD"



## Do You Require More Capital?

For ten years, Royal Securities Corporation has been associated with the development and financing of Canada's most successful pulp and paper enterprises. Among them are:

*Abitibi Power and Paper Company.  
Brompton Pulp and Paper Company.  
Mattagami Pulp and Paper Company.  
Price Bros. and Company.  
Riordon Pulp and Paper Company.  
Fraser Companies, Limited.*

Do you desire to pay off floating indebtedness; increase your plant capacity; or acquire additional properties? If so, why not let us suggest ways of financing your requirements? Our Engineering and Statistical Departments are at your disposal.

**Royal Securities  
Corporation  
L i m i t e d**

164 St. James St.,  
MONTREAL

58 King St. West,  
TORONTO

# Canadian Forestry Journal

VOL. XV.

OTTAWA, CANADA, NOVEMBER, 1919.

No. 11.



Four happy couples dancing on a cedar stump in a British Columbia logging camp.  
The orchestra occupies a springboard.

FACULTY OF FORESTRY

JAN 1919

UNIVERSITY OF TORONTO



How strange the old-time pictures of sport would look today—baseball teams boasting at least half-a-dozen sets of whiskers—full-bearded cricketers—champions of the scull with their chins concealed.

Today the athlete knows the importance of the well-shaven chin. He is conscious that he is most keen when he is well-groomed—just as is the business man and the soldier.

For men who love outdoor life and sports, men of virile minds and active bodies, we have designed a Gillette Safety Razor with an extra stocky handle—the “Bulldog” Gillette, shown to the left.

Not that the Gillette needs a sturdy grasp. A light touch, with the angle stroke, removes the most stubborn beard with surprising comfort.

But there is a certain appeal in the thicker handle of the “Bulldog”. Ask to see this special set and appreciate the point for yourself.

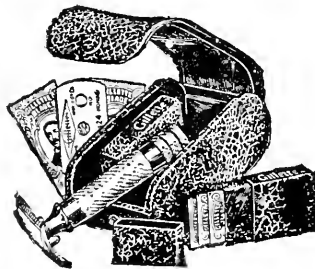

The “BULLDOG” Set includes oval Morocco Case with two blade boxes to match, and 12 double-edged blades.

*The case, you will notice, is almost as compact as the famous Pocket Edition Gillettes, and the price is the same, \$5.00.*

*Sold by all dealers catering to men's needs.*



# Gillette

## Safety Razor





Gen. Chahoon, Jr., President of the Laurentide Company, disembarking after a flight in the forest protection plane.

## AIRCRAFT AND TIMBERLANDS

*By Stuart Graham, Manager, Aviation Department,  
The St. Maurice Forest Protective Association, Limited.*



Although lumber concerns have been rather pessimistic as regards the use of aircraft in forestry work, yet it is safe to predict that the time is not far distant when all large concerns will operate planes over their limits.

However, unless great care is exercised in the selection of machines and personnel, the pessimists will certainly win the day.

There are two broad classifications of aircraft, machines fitted with wheels for alighting on terra firma, and those constructed for alighting on water. The land machine is light and more efficient as regards fuel consumption, but owing to the lack of suitable fields for landing, it must be disregarded for our forestry work. For the flying boat or seaplane the Creator has given us thousands of square miles of perfect landing area, free from the cost of maintenance.

### SAVES THE BOSS'S TIME.

Aviation has greater opportunities in forestry work than in any other commercial enterprise. The logging superintendent wishes to visit oper-

ations a hundred miles from headquarters; the trip generally keeps him away from the office four or five valuable days. In place of this delay, he makes the trip by air, and alights on the shore of a lake a couple of miles from the site of the operations two hours after leaving home; he makes his inspection and returns home the same day. During the trip the aviator was not merely acting as chauffeur, but performed a double fire patrol over two thousand square miles of territory, and, if the weather proved favorable, made aerial photographs of a hundred square miles of country which probably had never been mapped, and only very inadequately explored.

### RESULTS IN MAPPING.

Let us cite another instance: an explorer is sent to make a detail report of a certain area of timberland. Before doing his ground work, he flies over the district, where he is able to study the relief map beneath him, making full notes of drainage, "burnt over," swamps, and density and types of growth. Whilst enabling

the explorer to make these notes, the pilot has covered the ground in such a manner that a complete photographic mosaic has also been obtained. The portion of this area of value to the concern interested may then be explored on foot, and the tramp through the burnt-over and swamp eliminated. The increase in the value of this combined information, viz, aerial observation, photographic mosaic, and ground report, over the old method of ground exploration can be well appreciated.

Machines used solely for the purpose of fire patrol will undoubtedly prove expensive, and it is through the performing of work such as outlined above, that fire protection work can be carried on. While in the air on other missions fires can be as effectively spotted as though machines were there for that special reason. The objection is, of course, raised that this auxiliary patrol work would prove inefficient, owing to the fact that machines would only be in the air when required by the concerns operating them, but their schedule of operations could quite readily be arranged in such a manner that the best possible surveillance of the whole area would coincide with the other work to be done.

#### CARRYING MEN AND PUMPS.

With a slight alteration in the suction pipe of the Fairbanks-Morse fire pump, any medium-sized seaplane can transport this apparatus to a lake or river near a fire in a very short space



"She's away!"

of time. Several pumps and a number of men can, in this manner, be placed on the scene very rapidly. Practice has shown that one of these pumps is as effective against a conflagration as the labors of fifty men. Whether planes are being operated by Forest Protective Associations, or other lumber interests, forest fires must be given priority over all other work, and some agreement must always exist whereby a private concern may be reimbursed for work in connection with fires their planes have been instrumental in extinguishing, on other lands than their own.

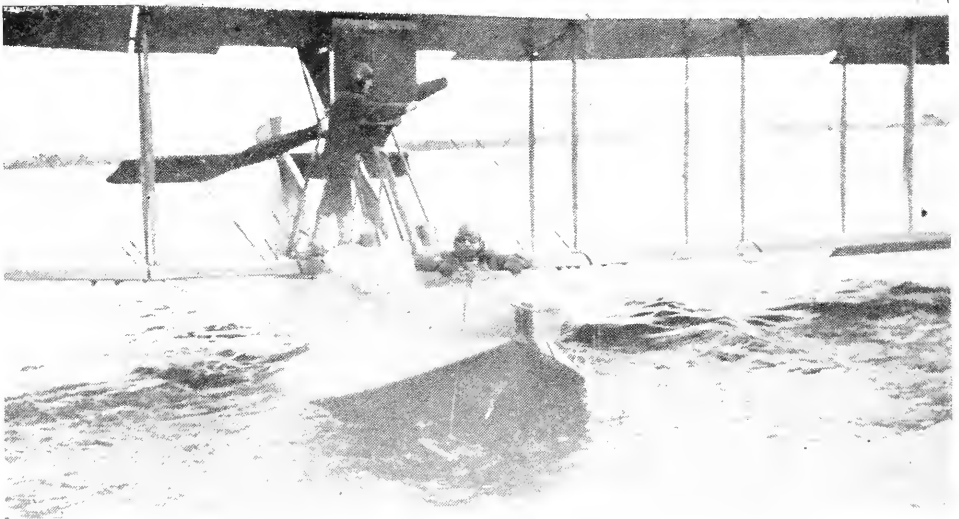

They're all on the wing now in Centre Quebec! Here is Mr. Henry Biermans, Managing Director of the Belgo-Canadian Pulp and Paper Company, Shawinigan Falls, who wanted to take a look at the bush country and did it by booking a forward berth on the Flyer.

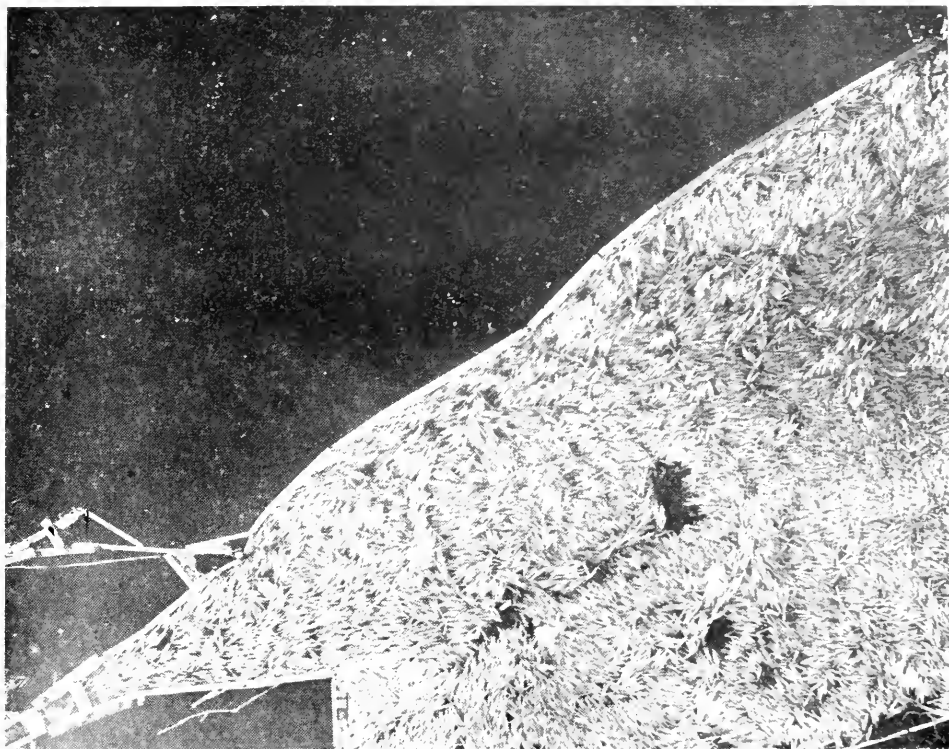

No, this is not a handful of wheat on a table-top. It is an aerial photograph of a log boom on the St. Maurice River, Quebec, taken by one of the seaplanes of the St. Maurice Forest Protective Association. The Forestry Journal is informed that by counting the number of logs in a square centimetre of the photograph, the total contents of the boom can be easily and accurately computed. It is declared to be more exact than by any other known method.

Several radio telegraph stations should be dotted over the area of flying operations, so that a fire may be reported immediately it is sighted, or a forced landing investigated by a second machine. Undoubtedly every air base should have at least two machines and two pilots, and it is only by this means that absolute satisfaction from the work may be expected.

#### SAFETY FOR HUMAN CARGO.

No serious-thinking business man should be willing to go into flying extensively unless he can determine what factors are responsible for his safety in the air, and these factors may be grouped—the safety of construction and design of the 'plane, the efficiency of the power unit, and the possibility of a safe landing in case of trouble.

Manufacturers of efficient aircraft test these 'planes by acrobatics, which strain all parts of the machine five to ten times greater than they are ever called upon to stand in commercial

flying, and the liability through constructional faults is nil, if the machines are cared for by a competent staff. The old danger of fire is also eliminated on a good make of machine, when properly cared for.

#### HIGH FLYING ON ONE MOTOR.

With the best make of motor car, you cannot guarantee a long trip with absolutely no engine trouble, the same thing is true of an aeroplane motor. The gas engine has been greatly improved, but is not perfect. To overcome this uncertainty, we must, when using only one motor in a 'plane, fly at an altitude of four or five thousand feet, which affords an opportunity to land on a lake, if necessary, about four miles distant in any direction, this distance being dependent on the direction and strength of the wind.

It may be interesting to the uninitiated to note that an airplane operates the same whether the motor is running or not, and can maintain the same speed. The motor does not govern

the speed of the machine in the air, but enables the pilot to attain or maintain a given height.

The flying boats loaned by the Department of Marine and Fisheries for the carrying out of experiments by the St. Maurice Forest Protec-

tive Association in co-operation with the Department of Lands of the Province of Quebec, have completed their season's work, and a full report of the work will be available for the next issue of the Canadian Forestry Journal.

## 745 FIRE-FLIGHTS MADE IN U. S. THIS YEAR

At the conclusion of the first season in which aviators have maintained an organized fire patrol in the United States, the officials of the Forest Service state that the record made by the airplane has proved beyond question its effectiveness as an aid in discovering and locating forest fires.

This new flying undertaking was performed by the Air Service of the War Department, with its personnel and equipment, and at the expense of that organization. For three months uninterrupted service was maintained, and a total of 745 flights covering 92,605 miles were made. Many fires were discovered, located, and reported in advance of the regular Forest Service detection organization.

Six patrol routes covering National Forest areas of high value in California were followed, and twice each day six Curtiss airplanes covered the better part of 9,000,000 acres of rough, mountainous, heavily timbered country. The average non-stop run was 160 miles; the average round trip, 320 miles.

### CRITICAL PERIOD.

With the opening of the hunting season in the middle of the second month of daily flying above the forests, the fire situation in northern California became critical and an extension of the principal factors necessitating a complete reorganization of the whole air patrol in California. De Haviland planes were substituted for the slower planes of smaller gasoline capacity and less climbing power. Two new bases were established. New daily routes were laid out, one of which covered 560 miles, and the service was extended from the original five to fifteen National Forests in California.

Beginning Sept. 1, eight airplanes covered twice each day more than 16,000,000 acres of National Forest, and incidentally, 5,000,000 acres of privately owned timberlands. Eight additional airplanes were used on alternate days to allow for necessary repairs and relief of pilots. Sixteen pilots and 22 mechanics were assigned to the work. Up to the first of October only six forced landings, with one fatality and no injuries to pilots or observers occurred. Dam-

age to the airplanes, considering the number of miles covered and the rough country patrolled, was negligible. No figures as to the cost of the experiment have been made available.

In the discovery of fires the air patrol showed itself 85 per cent efficient, and it is declared that it can be made practically 100 per cent efficient either by providing for a longer period in the air or possibly by making the time of flight correspond more closely to the hours of the day when the largest percentage of fires start.

Experience shows that while the effective "discovery radius" varies with atmospheric conditions and the height of the observer, an observer at an altitude of 5,000 feet can detect a fire at least 30 miles distant.

Though experience and familiarity with the country are important factors in accurately determining the exact location of fires, wonderful results were obtained by pilots entirely new to the region, but equipped with such maps as were available. One lieutenant, flying a De Haviland over an entirely new route, placed within one-half mile of its actual location a 200-acre fire that was 35 miles away. To see it he had to look almost directly into the sun.

### REPORTING FIRES.

On the whole, the reporting of fires—as distinguished from discovering and locating them—was not so satisfactory. Parachutes with messages attached, which were occasionally used, proved to be uncertain. Carrier pigeons released in the air and reports made by telephone and telegraph after landing were found to be too slow to ensure best results.

It is believed that the wireless, preferably the wireless telephone, offers the solution of this difficulty in the air-service fire patrol.

Without wireless or some other method of hastening the reports, the airplanes can never function as efficiently as the present lookout system, say the Forest Service officials. In the matter of procuring reports of the progress of fires already known to be in progress, it has been found entirely practicable to get quicker, more complete, and more satisfactory reports by

mean of the airplane than by any other method so far tried. This applies either to small, widely scattered fires, or to large conflagrations.

It seems possible that the use of airplanes has been beneficial also in lessening the number of fires. One valley in Southern California until this year has been the scene of repeated devastating fires, due no doubt to carelessness. With airships flying overhead twice daily, the valley has been without fires. The moral effect of the air patrol is credited with the change.

As a result of this season's record a request has been made for continuous daily airplane patrol of all the National Forests in California.

### FRANCE SEES A FOREST FIRE.

Paris, France—Forest fires, always at this season of the year prevalent in the south of France, have become more or less alarming along a 30-mile front between Toulon and Nice. Already about 20,000 acres of woodland have been consumed. The wind, unfortunately, continues to blow with violence. The hamlets in Fumas, Campaux and La Male were destroyed. In one night the Dum forest, with big reserves of cork, was wiped out.

The conflagration spread to the seashore, reaching Canadel, where ex-Premier Ribot has property. His park was destroyed. Visitors to his hotel got away by motor car and on a tug sent by the Maritime Prefecture.

The loss of the cork, which is an important industry in the Department of Var, will entail widespread unemployment. The hills of Esterel and Maures have suffered severely. The flames are being fought continuously by troops and inhabitants. Malevolence is suspected as the cause of the outbreak.

### NEW JUNIPER OIL INDUSTRY.

A new industry has been established in Deseronto, Ont., known as the Quinte Chemical Co., Limited, with a capital stock of \$40,000. Juniper oil will be produced from the juniper bush and berry, cedar oil from cedar wood, and hemlock oil from hemlock wood and bush. The company has a contract for the purchase of all the product that the plant can produce at current market prices.

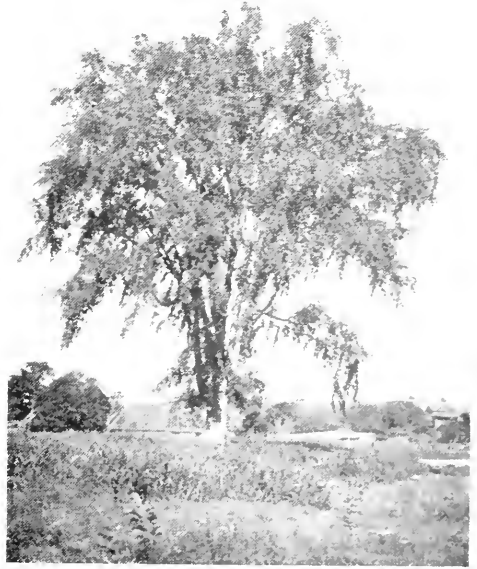

### A PERFECT ELM TREE AT CONESTOGO, ONT.

The Elm tree shown in this picture stands alone in an open bottom land pasture in the valley of the Conestogo river, opposite the village of the same name and about one mile above where the Conestogo joins the larger Grand river.

The valley in which the tree stands is a typical rich alluvial river bottom which in pioneer days was covered with a heavy timber growth. In many places along the river there are still groves of fine elm, soft maple, rock elm, basswood and occasionally a few hackberry trees. In the groves, however, the trees do not reach the perfection that is shown in the Conestogo elm.

I lived in the village of Conestogo from 1877 to 1881, but at that time I was not particularly interested in trees and it is only within the past few years that I have given much attention to the remarkable symmetry and beauty of trees that stand out in the open where they have room for natural development.

ORPHEUS MOYER SCHANTZ.

Chicago, November, 1919.



NO-MAN'S LAND AT YOUR DOORSTEP.

The product of unregulated lumbering, a litter of slash, and inevitable forest fires. No seed trees left, no forest reproduction, wasted soil. The stumps show the size and density of the original forest. Is this the best that Canada can do as absolute master of 90 per cent of the total forest lands?

## PRACTICAL STUDIES IN FOREST MANAGEMENT

The work on the permanent experimental plot which has been laid out on the Nepisiquit river, through the co-operation of the Bathurst Lumber Company, the Conservation Commission and the Crown Land Department of New Brunswick, is progressing very favorably. An area of 490 acres of forest land has been set aside for 25 years by mutual agreement and the Bathurst Lumber Company is cutting this area according to many various regulations and systems laid down by Dr. C. D. Howe, of the Conservation Commission with a view to finding out what change may be made in the rate of growth and nature of the reproduction resulting from each of the various methods of cutting. On some of the area all the slash and brush is being burned and all material in the tops suitable for pulpwood is being taken out. Mr. Angus McLean, general manager of the Bathurst Lumber Company, is taking a keen interest in this experimental cutting and thinning and deserves much credit for making possible this

valuable experiment even at an increased cost for logging, it being one of the first and most extensive experimental thinnings being undertaken in Canada. Mr. John Lordon, superintendent for the Bathurst Lumber Company, has been in charge of the logging for the Bathurst Lumber Company, and R. D. Jago, of the Forest Service, laid the plot out and has been in charge of the cutting for the Conservation Commission. Mr. Herman Good, a returned soldier, who won the Victoria Cross, has filled the position of camp foreman over the 50 men employed in a very satisfactory manner.

Dr. C. D. Howe, of the Conservation Commission, picked out the site for the plot and expects to visit the area for the third time in December, after most of the cutting has been completed.

W. M. Robertson, B.Sc.F., of the Conservation Commission, is in charge of the plot at the present, having relieved Mr. R. D. Jago recently, who had to return to Fredericton.



THIS THING IS THE FOE TO GOOD BUSINESS!

A damaging forest fire swept across the slope shown in the photograph. Soil washing quickly followed. This is usually the case on steep slopes where the soil is loose.

As a result of one bad forest fire on a British Columbia slope, all the water that formerly took six weeks to drain off into the rivers now comes out in about two or three days. A lumber company uses the stream in question to float its logs. It used to take everything out in one year's drive. Now the water conditions demand a three years' drive. That is one way by which the timber consumer pays the increased costs due to one forest fire.

## AIRPLANES IN WESTERN FORESTS

Portland, Ore. The expense of operating airplanes for forest fire patrol has so far been borne by the Air Service of the United States Army. During its experimental stage this can continue, but the success of the patrol foreshadows the time soon when the cost of the service must be paid for pro rata by the owners of the timber protected, according to the Forest Patrolman, a new leaflet to be issued periodically by the Western Forestry and Conservation Association. Its first issue is in the interests of forest fire protection and it further says in connection with the use of airplanes:

"Whatever may be the cost of maintenance and operation of airplanes in forest fire patrol

work, it can never mount to the total of the annual money loss by forest fires. The individual machine represents an outlay of several thousand dollars; keeping it in shape for continuous service takes perhaps hundreds of dollars; salaries of fliers and mechanics are high. In comparison with these figures is the annual charge of ten million dollars to destruction of marketable timber. Last year the forest fire loss on the Pacific coast and Inland Empire is estimated to have been six and a half million dollars. Detection of fires which did this damage when the blazes were in their incipency, would have enabled the fire-fighting forces, federal, state and private, to have prevented a good part of this loss."

## WHAT TREE PLANTING DOES FOR PRAIRIE FARMERS

By Norman M. Ross, B.S.A., B.F.,  
Chief of the Tree-Planting Division, Indian Head, Sask.



GROWING WINDBREAKS ON THE PRAIRIES.  
Scotch Pine Plantation twelve years old. Dominion Forest Nursery Station,

The system under which the settlers of the prairies of Manitoba, Saskatchewan and Alberta are assisted by the Forestry Branch of the Department of the Interior has now been in operation since the spring of 1901. Under this system any settler can secure from the Forestry Branch nurseries sufficient quantities of hardy trees suited for prairie conditions to establish practical shelter-belts around his farm buildings and gardens. These trees are furnished free of charge. All the settler has to do is to properly summer-fallow the ground he wishes to plant the trees on and to agree to plant and care for the tree belts as instructed. Up to the present time 53,142,425 seedlings and cuttings have been supplied to farmers. The average distribution for the past five seasons has been 4,922,615 per year and the average number of individual shipments practically the number of farmers to whom trees are sent) per year during the same period has been 4,405. The species sent out in this way are: Manitoba maple, green ash, caragana, Russian poplar and Russian willow.

In addition to these broad-leaved species evergreen conifers of Scotch pine, jack pine,

lodgepole pine, and white spruce have been sent out in limited numbers since the spring of 1912. These evergreens are sold at a nominal charge of \$1 per 100, which covers the cost of growing and handling in the nursery. Of these evergreens 933,000 have been distributed, 140,000 being about the annual distribution at the present time. The evergreens appear to be particularly adapted to withstand the severe conditions of the prairies, and, when once established, will withstand periods of drought and heat that are often fatal to the broad-leaved species.

The stock supplied for the planting is all grown on the Forestry Branch nurseries at Indian Head, Saskatchewan, and Sutherland, Saskatchewan, and is raised entirely from seed collected in the west. Maple and ash seed is secured in the Qu'Appelle valley, Saskatchewan, or in the neighborhood of Portage la Prairie, in Manitoba. The spruce and pine seed is collected on the Dominion forest reserves in Manitoba and Saskatchewan. Scotch pine planted on the Indian Head Nursery in 1906 has been bearing fair crops of cones since 1916 and a sufficient supply of good seed is now obtainable from locally grown trees. The Russian poplars



and willows are distributed as unrooted cuttings.

In addition to the trees and cuttings a very considerable amount of maple, ash, and caragana seed is sent out when a sufficient supply is available. It is a very easy matter to grow these three kinds from seed, and many farmers find it more convenient to raise their own seedlings than to have them sent directly from the nursery. This is especially the case where the farmer lives a long way from the railway with a poor mail service. Under such conditions a shipment of trees may remain at the express station for several days before notification reaches him and the chances are that the young plants may become heated or dried up before they can be set out.

Encouragement is also given to planting trees around rural schools, and considerable numbers of trees have been supplied for this purpose. In Saskatchewan the Provincial Department of Education is actively co-operating with the Forestry Branch in endeavoring to interest the trustees of the various schools, and all applications for trees for rural schools in the province are made through the Department of Education, the school inspectors undertaking to see that the ground is properly prepared and that as far as possible proper care of the trees is given after planting.

A large number of bulletins are distributed each season, and recently Bulletin No. 1, "Tree-

Planting on the Prairies," has been published in revised form. Copies may be had free on application to the Forest Nursery Station, Indian Head, Saskatchewan.

On each of the Forestry Branch Nursery Stations a considerable portion of the grounds is planted out to ornamental shrubs, flowers, and lawns as a demonstration of results that may be secured under prairie conditions in the way of beautifying the farm grounds. No ornamental shrubs or flowers, however, are sent out from the nurseries.

### TELEPHONE LINES IN N. B.

Col. T. G. Loggie, Deputy Minister of Lands and Mines, New Brunswick, announces that the construction of the telephone line up the Nepisquit river from Bathurst, which has been delayed by the non-arrival of the wire until a few days ago, has now been commenced and several miles of line has already been strung. This line will penetrate about 70 miles from Bathurst into the very centre of the province and is part of the policy of constructing woods telephone lines and lookouts in the interests of better fire protection in New Brunswick. The construction is being carried out by the Bathurst Lumber Company according to a standard agreed on, and the cost is equally divided between the Forest Service and the Bathurst Lumber Company.



TREE GROWTH ON THE PRAIRIES.  
Saskatchewan farm residence in 1918. In 1904 this land was bare prairie.



Ornamental planting on the prairies, showing a development of only five years.  
Photo taken at Indian Head.

## FIGHTING "BAD YEARS" BY PLANTING TREES ON PRAIRIES

*By Archibald Mitchell, Coaldale, Alberta.*



### A Practical Explanation of What Trees Can do and Have Done in Antidoting Crop Waste



Without any doubt, the thoughts of most of our public men, at least our western men, are being directed at the present time towards the problem of how to keep our settlers on the dry prairies. This is true, whether they are concerning themselves with the supply of hay for the winter, the relief of the financial situation, or even as we are, the study of irrigation problems.

The question is the same: What can we do to keep our farmers on the prairies and make their business more stable and successful? It has occurred to me that it might be well worth while to consider briefly the place that trees could be made to bear on the problem.

#### CANADA'S DRY BELT.

We are at the present moment, not far from

the centre of a region differing from any other part of Canada and covering some 400 miles east and west and some 200 north and south. This land is very fertile and produces great crops in years when sufficient moisture is available. Its annual precipitation is, however, very scanty, averaging some fourteen inches or less (the last two years it was 6.60 to the end of July) not enough for grain crops.

A system of summer fallows has been adopted which stores up in the soil, moisture from the previous year, and this, added to the precipitation of the current year, makes crops possible. It will be seen at once that any means whereby the precipitation can be preserved for the use of the crops even in a small degree must be well worth looking into.

## WIND INJURY.

This region is also noted for its frequent high winds, and after three or four summer fallows it is found that the soil becomes divided into such fine particles that in an ordinary spring a great deal of the top soil, the very best of the fertility, is blown away and lost. In a really dry and windy year such as this has been, this loss from soil drift becomes alarming in extent. In many cases all attempt at raising a crop is a failure on account of both soil and seed being blown away.

This soil drift is taking place more or less every year and if allowed to continue cannot fail to result in a loss of fertility that we cannot hope to replace possibly in centuries.

These are facts, no matter how disagreeable they may be, and they must be met if men are to remain on their farms on the dry areas.

I say "wind injury" for the wind not only causes loss through soil drift; it sometimes blows the growing crop right out of the soil when young and shells it out when ready for the binder and is more or less a menace all along the line till it is in the stook.

Add to this the loss it causes through accelerating evaporation, and you will see that the wind problem is one of the very first importance when we come to consider the permanence and stability of agriculture on the dry prairie.

## TREES ON IRRIGATION DITCHES.

We went to Coaldale in 1911 and that spring and for several others afterwards we found could scarcely breathe for days at a time from dust storms. Seed was blown away repeatedly and young plants and cuttings were destroyed by the thousand from the erosive action of the blowing soil.

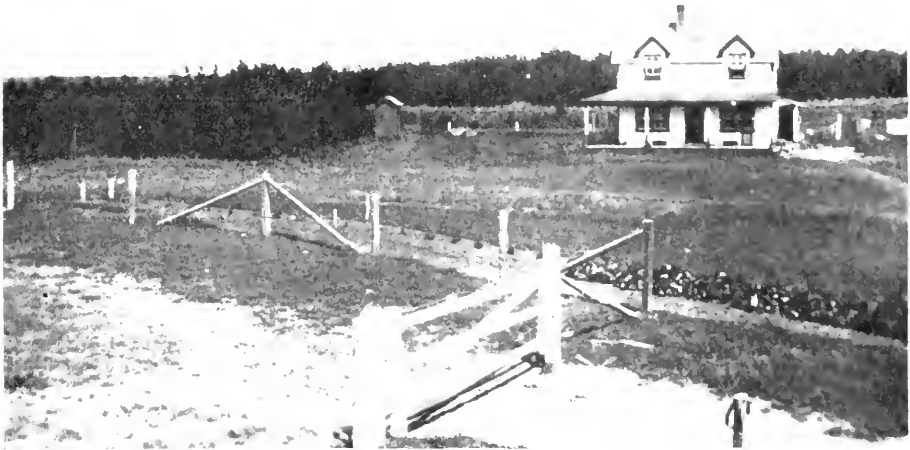

WINDBREAKS ON AN ALBERTA FARM SIX YEARS AFTER PLANTING  
Trees supplied by the Dominion Forest Nursery Station, Indian Head, Sask.

We know that Brome Grass roots and Western Rye will help to bind such soils, but oftentimes it is difficult getting the roots of these grasses to remain long enough in the soil to germinate.

We also know that corn roots will help to bind soils, but the corn is not here yet, and meantime the question rises: are we doing all we can to solve this most important problem of wind injury?

In 1912, we began planting shelter belts across the land and now we have no trouble from wind whatever. People coming in on a windy day remark the shelter we enjoy and it has occurred to me that a thorough system of farm forestry might yet be the salvation of this part of the country. Such a system on dry land still presents some unsolved problems, but there will be no difficulty in growing plenty of shelter trees in the irrigated sections.

Trees, like other growing things, depend on moisture. Given sufficient moisture we could grow trees right among the grass of the open prairie. Under irrigation, where there is plenty of moisture there is no difficulty.

One of our best shelter strips runs for half a mile along one of our main laterals. It consists of a row of maple and cottonwood and was planted in 1912. Two men planted it in a day and it was cultivated twice in 1912, and twice in 1913. Since then it has had no attention, not even being flooded with water. The ditch runs only about half a dozen times a year and then only for two or three days at a time. The cottonwoods are some six feet from the edge of the ditch and yet the belt is now 20 to 24 feet in height and many of the trees are 8 inches in diameter. We got those young cottonwoods, about two feet high from the river bottom and there was nothing to prevent our neighbors from doing the same at the same time. If they had, or even if two or three had, what a beautiful country there would now be and how well sheltered.

We were not alone in this planting, for Mr. Pawson, about two miles away, had planted a similar belt a few years previous, which is now nearer thirty than twenty feet high. This belt is also along a permanent ditch bank and has cost nothing to maintain since it was planted. It makes a fine showing from all over the country and it seems to me some effort should be made to induce other people to do the same.

There would be no extra waste of land as there are usually 6 to 8 feet of waste land anyway alongside these ditches. Planted on one bank, there would be plenty of room to scour the ditches when necessary.

When irrigation began in Alberta, I was informed by people who came from irrigated districts in the south that trees would soon spread all along the ditch banks though seed being washed down with the water, but it seems our water flows through a treeless region and there is very little indication of anything of natural tree growth in any of the ditches.

The planting of cuttings and seedlings will be necessary.

#### EDUCATION THE SECRET.

A vigorous campaign of education carried on among our irrigators and perhaps a few prizes offered for the best half-mile of such shelters two or three years old would stimulate tree-planting in the irrigated sections and go a long way towards stopping trouble from wind injury.

A neighbor remarked the other day that in 1914 the only oats he had were those sheltered in the lee of a fill about three feet high across his land. All the rest were blown away when six inches high. The three foot bank sheltered some twenty or thirty yards and I could not help thinking if he had had as good a shelter belt as Mr. Pawson's, 30 feet high, how much more he would have harvested. Certainly much more than would have paid for the whole cost of the shelter belt, several times over.

Trees pay on the farm, and with irrigation, tree growing is easy. All it wants is education to set men thinking in the right direction. Tree growing on the dry farm is a different proposition.

#### TREES ON A DRY FARM.

Here, as elsewhere, the main question is water, and the only water available is that from the natural precipitation.

Fortunately, tree crops require only from half to one-third the rainfall that grain crops do so that if we can grow wheat there should be little trouble about trees. There is, however, so little moisture to spare that every effort must be made to preserve what is needed for the use of the trees. In grain growing, as we have seen, this is done by summer fallowing every other year, but trees are a permanent crop and systematic summer fallow is impossible.

#### PREVENTING WATER LOSSES.

There are three ways in which water may be lost from the soil: draining away into the subsoil and so into springs, transpiration through the leaves of grass, trees, and other plants, and direct evaporation from the surface. In this country we have no loss from subsoil drainage, loss by transpiration we must have or trees will die, and the only things left for us is to do all we can to check evaporation from the surface.

The two prime evaporative forces are the sun and wind, and if we are to be successful in our farm forestry we must so arrange our plantations that the action of these two be checked as much as possible.

#### WIDE BELTS AND DENSE FOLIAGE.

Dense foliage means shade, and therefore the denser we can keep our foliage or forest crown, the less evaporation we will have through the direct rays of the sun.

A narrow strip of trees, a single row, or even three or four rows allows the wind to pass through almost as easily as if there were no

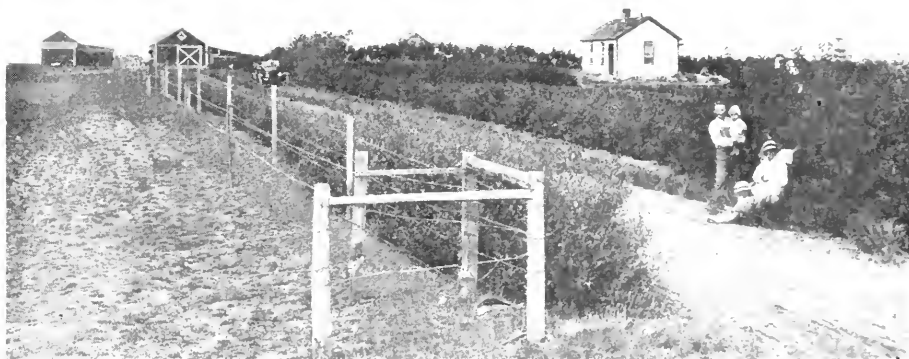

FARM OF A SASKATCHEWAN SETTLER A FEW YEARS AFTER STARTING.  
Trees supplied by the Dominion Forest Nursery Station, Indian Head, Sask.  
Photograph taken in 1919.

trees there at all, therefore our shelter belts should be wide enough and the trees close enough to present a solid mass to throw the wind over instead of allowing it to pass through and dry up the soil underneath.

These are the first principles we must observe in our farm forestry, dense shade and wide belts. The moist condition of the soil under the trees is the first consideration and this is

the only way we can preserve it in a plantation that is not irrigated.

From this it would appear that all we have to do in order to make a success of prairie planting, is to plant trees with a dense shade, and plant enough of them. This is quite true, but another consideration enters here.

#### MIXTURE OF TREES.

Our choice of trees is very limited on the



prairie owing to the rigor of the climate and especially is this true of trees having dense foliage.

In these, we are practically limited to two species, Manitoba maple and spruce, so that our prairie plantations must of necessity consist very largely of these two species.

Prairie planters, however, demand rapid growing trees in order that they may have shelter as soon as possible.

Spruce grows slowly especially in its young stages and it is difficult for the ordinary farmer to grow and costs a good deal to buy, so that we are almost confined to maple as our shade mixture.

The two best trees we have for rapid height growth are Russian poplar and sharp leaf willow. Ash and elm are quite hardy, as are some of the pines though slow growing, and some of each may with advantage be put in every plantation.

Half the trees should consist of maple or spruce or a judicious mixture of both. In the latter case, the labor of keeping the branches cleared away from the tops of the spruce till they are large enough to look after themselves, would add to the cost of establishing the plantation.

#### THE COST OF PLANTING.

The expense attached to growing trees is an important matter.

The initial cost of anything is never so important as the after-cost, the maintenance, and so we have to consider the cost and maintenance of our prairie forest belt very carefully.

As we have seen, our most valuable asset is moisture. This has been preserved for the use of the young plants by a summer fallow the year previous to planting and it must be preserved by cultivation among the trees as long as possible.

A single row of trees can be maintained indefinitely in this way, but the expense will also be indefinite, and no farmer can afford any additional indefinite expense either in time or in money.

Foliage shades the ground and therefore the closer trees are planted consistent with economy, the sooner the branches will meet and check evaporation and the sooner the work of cultivation will be over and the expense of maintenance be done away with.

The planting width as usually practiced on the prairie has been 4 feet by 4 feet, and in the first few years has proved quite satisfactory,

but these dry years are opening up the question of whether 4 by 6 might not have been better in a real dry year on the real dry prairie.

At least the trees would have had as much again soil space to draw moisture from. The larger spacing would probably require an additional year's cultivation, but it is possible this would be more than offset by the lessened expense in planting. Our data on these matters are very meagre, if, indeed, any are available at all for the real dry region under consideration.

#### PLANTING MATERIAL.

I have often said elsewhere that proper tree sheltering on the prairie farms will never be done if the farmer has to buy all his own material. He will have to grow the most of it himself and after he has got into the way of doing it he will neither find it difficult nor expensive.

A pound of maple or ash seed costs a dollar to a dollar and a half and will produce about 2,000 plants if sown on well summer fallowed land and well cultivated during the summer. This will take a row about 150 yards long. The plants can be easily plowed up as seedlings which cuts down expenses very considerably.

Along with this a row of about 500 Russian poplar cuttings should be planted about a foot apart, from which to take cuttings for future plantings. They would not take up much room and about three runs through with the cultivator every year would be all the attention they would require. They cost about \$5.00 per thousand.

2,700 trees are required to plant an acre at 4 by 4 feet and 1,800 at 4 by 6 feet. All plant material should be used as seedlings and cuttings. They are easier to plant and a better percentage of growth results.

A man and a team can plant 1,000 trees in a day, and cuttings planted with a cutting iron or a spade can be planted much faster, so that the cost of planting can easily be estimated.

Cultivation will be carried on three times during each of the first two summers and about once or twice the third one, if the planting is 4 by 4. Probably two more cultivations will be needed if the trees are 4 by 6. After that the plantation will be self-sustaining.

#### TEN PER CENT OF LAND UNDER TREES.

We do not know how many strips of trees will be required to completely shelter a quarter section in a reasonable time, and we do not know how wide they will need to be. Probably three strips running across the field N. and S.

will be necessary and they should be at least four to six rods wide, that is, each strip will be 4 to 6 feet across in extent.

This, with a few short shelter strips round the buildings will make up the ten per cent we are told every really habitable land should have under trees.

A country planted up in this proportion and in this manner would present, in twenty years, a very different appearance from what the prairie does now.

Farming and living conditions would be improved in various ways. The precious snow of winter would not be blown away and lost as it is now, and there would be a great deal less evaporation from the fields.

Professor King, of Wisconsin, tells us that the shelter of a belt of trees 15 to 25 feet high caused a difference of sixty-six per cent in evaporation as between a point 20 feet from the trees and a point 300 feet away. Everybody knows how the wind dries things out, but when it is backed by actual test in this manner we can readily understand the place that tree-planting might be made to take in stabilizing the farming industry on the dry prairie.

**SUBSTANTIAL SHELTER.**

If even only ten per cent of the cultivated land were planted in twenty years it would be well worth while.

It would not take long for the individual farmer to plant his quota. By planting half of each strip, i.e., two acres at a time and that same season preparing the other half for the next year's planting he could have three belts of two acres each, or 12 acres in all across his farm in six years.

When he was finished, the two acres he had planted first would be six years old and ten to fourteen feet high, already a shelter and the possession of which would more than repay him for his time and trouble. Six years later, that is twelve years after he began, his farm would be substantially sheltered.

Three men and a team would do the whole season's planting in not more than three days; time that any man can well spare from getting in his crop. Three cultivations of each year's planting would take up some half day each time, and two men would knock down the seeding weeds left in the rows in a day.

After all, two acres across a quarter section consists of only eight rows at four feet apart, and I am satisfied that most men would be surprised how little time it would take.

Systematic planting carried on in this way all over the country would soon change its appearance, and not only its appearance, but it would go far towards changing the whole conditions of living on the prairie. There would be at least less wind damage either to crops or soil. There would be less moisture lost from the fields. Stock would be better sheltered and

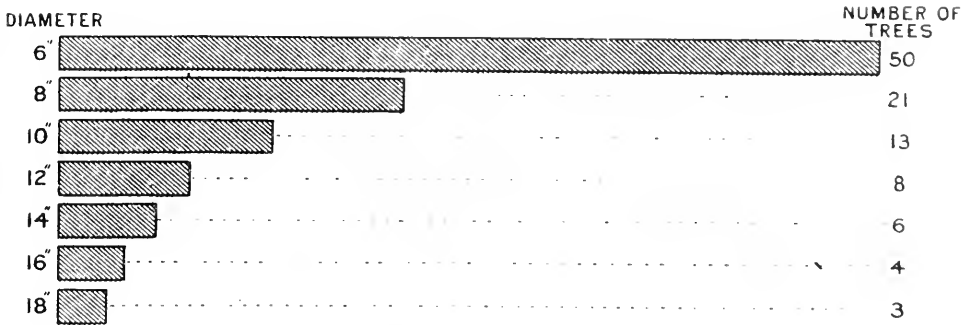

**NUMBER OF TREES OF VARIOUS SIZES  
REQUIRED TO MAKE 1000 FEET OF LUMBER**

*Courtesy of Conservation Commission, State of New York*

so would the people. Weeds would not tumble so far, and farming conditions would be improved and stabilized, a condition very much to be desired at the present time.

There are, of course, details we cannot touch on here that would have to be worked out, but this is a brief statement of a side of prairie settlement that has had little or no attention paid to it hitherto.

At first sight it looks a long job to plant ten per cent of the prairie, but does any one doubt if it would be a benefit after it was done? It will take time to do, but it will have to be done some time. The mind recoils from contemplating the prairie, bare, windswept, treeless, soil-drifted, dry and comfortless for ever.

A beginning towards the real sheltering of our fields must be made sometime, and soon, before the best of our fertility is blown away.

Is there any reason why that beginning should not be made now?

Irrigation, and the planting possible through irrigation will help some, but we all know that

by far the greater portion of the real dry region can never be irrigated, and it does not take much foresight to see that a repetition in a century of the series of dry seasons we have experienced since settlement began in western Saskatchewan and southern Alberta would go far towards converting our good dry prairie into little better than a desert.

It is a big question; it is a pressing question, and it is high time something was done. Our planting efforts on the prairie have hitherto been directed only towards sheltering the gardens and buildings. It is time they were directed towards where they really belong the sheltering of the farm and the preservation of the soil.

The area under review is so large, its soil so rich, and its value as a wealth producer so great that these days of post bellum retrenchment and development, we cannot afford to neglect it.

Forestry is Canada's national problem, and not the least important branch of that national problem is that of forestry on the prairie farms.

### TWIN ELM TREES.

The enclosed picture of two curiously joined American Elm trees (*Ulmus Americana*), was taken at Conestogo, Waterloo County, Ontario, in 1918.

These Siamese twin trees are located on a flood plain of the Grand river, opposite the village of Conestogo. The larger of the trees measures about 42 inches in diameter at its base, the smaller about 38 inches. There is nothing on either tree that would indicate how these trees became joined, and there are no local traditions concerning them. From the angle of the joining limb as it leaves the larger tree, it is reasonable to suppose that it belonged first to that tree.

I have known the twin trees for over forty years, and while I have seen many curious natural grafts and other twins, none have been so widely separated or so evidently not from the same root.

The flood plain on which the trees are located is subject to heavy overflow each spring and all of the trees near the river's edge are heavily scarred by ice.

The twins stand about five feet apart and the joining limb is about 8 feet above the ground level.

ORPHEUS MOYER SCHANTZ.

Chicago, November, 1919.

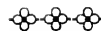
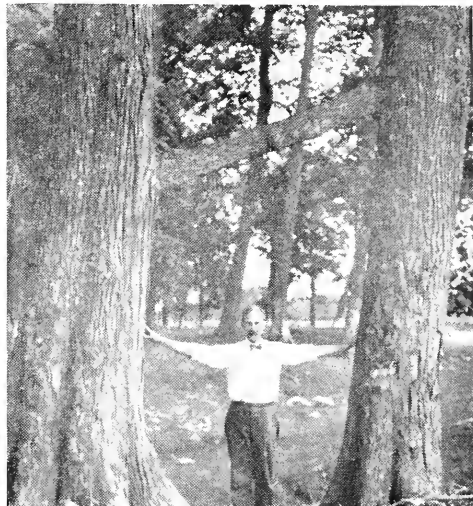
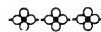



## What a City Can Do With Forest and Stream



*The Des Plaines River, flowing through heavily wooded tract of Chicago's municipal forest.*

*An early spring scene in the new forest. The ground is covered with the blueberry plants.*



## FOREST PLAYGROUND BUILT BY CIVIC GOVT.

*Written for the Forestry Journal by M. E. Bascom.*



Chicago's Beautiful Woodland Preserve, Created by Popular Vote, as a Civic Health Investment



A magnificent domain of virgin forest, heavily wooded river banks, hardy growth and flower-starred marsh, is the invaluable heritage of Chicago's two million and a half population, lying at their doors and secured to them and their posterity for ever under the forest preserve law which allowed the Forest Preserve Commission of Cook County to purchase and to care for a forest preserve comprising at the present time over 12,575 acres. The money was voted at popular election to purchase these timber

lands and for the necessary work in opening them to the public. The Forest Preserve Commission is entrusted with the selection of these lands and with their proper protection and care.

The project is an old one, suggested many years ago by certain nature loving citizens who did not want to see the natural beauties of the region destroyed by the inevitable growth of the city. But many years went by before much popular interest was aroused in the matter. Great enthusiasm was aroused eventually, how-

ever, and when the matter was finally put to a vote, it carried by a good majority.

#### GROVES OF MAPLE, ELM AND OAK.

In the few years that have passed since the voting of the bond issue a series of woodland tracts surrounding the city has been purchased and opened to the public comprising in all nearly 15,000 acres, while other tracts are being added from time to time, the plan calling for the ultimate ownership of about 30,000 acres. To date it is estimated that \$3,000,000 has been paid out on this project.

There are at present 16 separate tracts selected from the finest sections of forested land, along river and creek courses, to be found in northern Illinois, and they have been chosen with careful discrimination. They include many of the historic spots in Cook County, for though Chicago and Illinois are young, the county is nevertheless teeming with romantic tradition and most thrilling history. The tracts are heavily wooded and include remarkably fine maple, elm and oak groves, and numerous wonderful old trees. Some of the maples in particular are said to be from 700 to 1,000 years old. Old Indian burial grounds, relics of a flint chipping station, the old home of Billy Caldwell, or "Sauganash," the famous half-breed Indian chief, and friend of the early settlers; dim Indian trails, the site of an ancient Indian fort, a geological hunting ground of world wide fame along the Sag, bubbling springs, tamarack swamps, swallow cliffs, one century-old log cabin, eight acres of hawthorn and wild crab apple trees, an old stage coach tavern, and one or two quaint old churches lend picturesque variety and romantic interest to the winding trails through the preserve.

#### FLOWER AND BIRD PARADISE.

The boundaries are exceedingly irregular, and the tracts are quite detached from one another in most cases, because they are so selected as to include everything of interest, even an isolated old oak or elm of unusual size and beauty and not to include any uninteresting stretches.

Wild flower and bird paradise it is indeed throughout the early spring days, and the great populace of Chicago has discovered and is using this great beautiful picnic ground in the way it should.

This has been attained partly by the educational work of the daily press which has been championing the wild flower and the forest tree

of late and has done much to teach many a misguided lover of nature to "love the wild rose and leave it on its stem."

But more than this is needed to preserve the beauties of this series of forest tracts for future generations. Severe penalties are awarded those caught picking flowers and leaves, and fires are absolutely prohibited except in the places provided for them and then only by permission of the foresters.

Boy Scouts and the Camp Fire Girls have found the preserves an ideal camping ground, and as wells are to be dug and more good highways added the advantages of the woods for camping purposes will be greatly increased. Fire pits are provided at frequent intervals in open spaces throughout the preserves. Good auto roads run through all of the tracts and all are within fairly easy reach from electric and steam lines at reasonable fares. Picnic grounds with tables are provided in cleared spaces, and baseball, golf and tennis grounds, in the larger tracts. Comfort stations, parking spaces for autos, dancing pavilions, etc., are to be found at intervals, usually at the main entrances to the various sections.

#### MANAGED BY A FORESTER.

The entire preserve is divided into eight districts and a District Forester with a staff of caretakers is in charge of each. The public is meant to use this wonderful playground to the utmost and to get full benefit from it, and for its own good is prevented by stringent laws and vigilant guards from abusing the privileges.

There are several interesting streams flowing through the preserves; the Des Plaines, the historic highway by which Joliet, Marquette, La Salle, and their followers reached central Illinois; the Chicago, which to the north is left to its old natural meanderings through beautiful woodland stretches, though to the south it has become a highly commercialized stream; the mystical little Skokie, long but narrow ribbon of water with its flower-covered marshes; Salt Creek, which the Indians called "Beautiful Little River," the Sag, the Calumet, and the DuPage, the two last just touching the edges of the preserve.

It is the proud boast of the Board of Forest Commissioners that every penny of the taxpayers' money was used to pay for land, and that by exercising reasonable economy the general administration expenses have been kept down to less than three per cent of the budget.

# THE STATE AS BOSS OF ITS FOREST PROPERTIES

By Robson Black, Secretary,  
Canadian Forestry Association, Ottawa.



## A Permanent Forest Asset Easily Within the Power of the Canadian People—The Lumberman's View



Canada is a forest country, full of lumbering and empty of forestry. Over sixty per cent of our total area is unfitted for agriculture. Of New Brunswick and Nova Scotia, for example, fully seventy per cent will never pay a profit to the plow. In Quebec, about nine million acres are being tilled, out of more than 250 million acres of area. About two-thirds of Manitoba is for timber-growing solely, and in what is commonly called "treeless Alberta," not more than 40 per cent of its 163 million acres are fit for cereal production, and in 1915 only 6,000,000 of Alberta's acres were tilled. Canada's most widely distributed crop therefore is wood, the harvest of the timberland.

### THE DOWN HILL TENDENCY.

Contrary to usual belief, forests are not a self-perpetuating asset. If it were so, Canadians would fear nothing from the bush-whacking programme of armies of men. If pine followed pine and spruce followed spruce, invariably and without loss of a century or more of time between crops, Ontario and Quebec would have quite as much pine and spruce as stood on the soil in 1850. But pine is a failing crop and so short is the supply that Ontario's cut is swiftly decreasing year by year. Spruce is not repeating itself except at long intervals—about 150 years in Central Quebec. The two great pillars of the wood-using industries of Eastern Canada are a pine log and a spruce log. Human ingenuity can bring along no substitutes. It is pine and spruce or disaster.

### WHICH DEFINITION?

Right here we come upon the cross-roads of Canadian forest policy. Lumbering, as commonly practised, means cutting timber for the market. This is good as far as it goes. The theory was quite sufficient for the days of superfluous forests and ill-developed machinery of government. Our forests are no longer superfluous. They are no longer a synonym of "wil-

derness," but take rank with the concrete national assets, to be charged up to governments as a vital public trust. In the wake of threatened exhaustion, we have sensibly asked for a definition of forest resources. Are they like the coal mine, exhaustible and non-reproductive? Or are they like the corn-field—subject to perpetual operation and perpetual harvests? This has brought us as a people to at least a sentimental alliance with the science of forest perpetuation. Forestry, like lumbering, cuts



The tree in the photograph is an oak of about two feet in diameter and some sixty feet in height which was totally demolished during a very severe electrical storm. The storm broke off the main stem some fifteen feet from the ground and splitting it up into small fragments, scattered them over a distance of about 300 feet. This tree may be seen on the farm of Mr. Geo. O. Stroh, about one mile east of Conestogo, Ontario.

timber for the market and must do so at a profit. But the axe of the forest engineer is a discriminating axe. While it cuts for to-day's market, it also establishes the pattern of the future forest. It looks out for the forest while looking out for logs. A cutting system that recognizes 1919 as the end of all Time is one thing; a system that takes 1919 as one milestone in a couple of centuries is quite another. The latter is, theoretically at least, the lode star of Forestry, and in all the older and efficient nations of Europe it is the very essence of public policy and practice. The forester and the lumberman in Canada are natural and inevitable partners. All lumbermen sooner or later, the world over, couple up their business to scientific forestry, and for good commercial reasons they do so only through the influence of compulsory state ordinances. It is so in France, Switzerland, Germany, Sweden and Norway. It is so on the 188,000,000 of the United States National Forests. In every country or case mentioned, commercial lumbering is held in leash by scientific forestry standards. In Sweden, no private woodland owner can cut a tree without permission of a district advisory board, dominated by state foresters.

#### THEORIES AND THEIR PROOF.

Necessarily, the idea of any modification of Canadian customs and forest exploiting jolts and irritates the "practical lumberman" of an ultra-conservative type. Himself often a mighty theorist, he takes his bitterest objection to the "theoretical training" of the forest engineer. Yet the forest engineer's "theory" of spruce reproduction, or lack of reproduction, in Quebec, has been so convincingly verified that within the past two or three years fourteen Canadian pulp and paper companies have engaged professional foresters. The ideal amalgam is, of course, the woods knowledge of the practical lumberman and the training of the forester, and as a matter of fact no graduated forester is recognized as a forest engineer until he has supplemented his college training with years of actual woods experience. The lumberman may bear in mind, however, that the so-called "theory" of the forester is the concentration of centuries of lumbering experience and biological lore, dominated by the idea that a forest should be treated as a reproductive crop. Moreover, the truly taught and qualified forester regards the practise of forestry in Canada as of necessity a compromise between his ideal and the actual economic conditions with which he must work.

#### COMMON OBJECTS.

Lumbermen, as far as the experience of the writer goes, scout the scheme of forestry management only as concerns the possibilities of private and patchy forestry on individual limits, with its likelihood of increased production costs. They go a long way with the forester, however. They desire, except in special cases, accurate inventories of their standing timber, close utilization, a knowledge of the rate of reproduction and influences affecting it. They are willing to pay for fire protection and are keen for efficiency at the saw mill end. This is the forester's programme, too. When the forester goes further and asks for modifications of present methods of cutting timber or suggests the burning of dangerous accumulations of slash following logging, lumbermen usually admit the desirability of such practice but with perfectly good reasoning declare it out of order except as a province-wide or nation-wide enactment. With no more justice may old-age pensions be forced upon a single firm of soap-makers than a scheme to save the national resources, by deferring part of the log harvest, be visited upon one or a dozen limit-holders. Indeed, even a province-wide application of practical forest conservation is a good deal complicated by the fact that the market for Canadian lumber and pulp and paper is not always domestically controlled. The greater percentage of all Canadian lumber and newsprint paper taken from our woods is sent abroad under conditions of extremely brisk competition from the United States, Scandinavia and as regards part of the timber trade in normal times, Russia as well.

#### LOGS AND THE PAPER MILL.

With the pulp and paper companies, having millions of dollars of capital buried in the huge unportable factories that cannot follow up the retreating border of the forest as can the multitude of saw-mills, the forest storehouse must be kept accessible to the plant. Such a vital consideration compels the introduction of conservative logging, compels a programme of reforestation. Most of the pulp and paper companies in Eastern Canada recognize fully the alliance between regulated logging and the security of their industrial investments. In fact, they, not primarily the governments, are taking the initiative to revise out-of-date and destructive public regulations—witness the recent request of the Canadian Pulp and Paper Association that new timber regulations should be established for Quebec.

It would appear, therefore, that Scientific Forestry and the wood-using industries of Canada are camping on the same lot. Not only the lumberman and the pulp man, but the forester quite frankly recognize that there can be no forestry in this country without prosperous private enterprises; there is no room for any forestry except that which is "economically sound." Ah, there's what rubs! Whose *economy* comes first? A logging jobber skins a tract of white pine that feeds a mill that maintains a town. His feat is economically faultless—for the jobber. And it is economically hollow and politically crazy for the ruined municipality and for the combination of municipalities called the state. Is it impossible then, to tone up private exploitation of forests so as to attain the great ideal of a perpetual timber yield, so as to inject permanence into lumbering and permanence into the whole machinery of its production and distribution? The trump card of state control over the forest properties is permanence, the rights of Tomorrow in an estate that belongs as much to Tomorrow as Today. The state's first consideration is, however, in more or less conflict with the tradition of Canadian lumbering. But commercial lumbering is open to evolution—an evolution that will finally establish the principle of permanent forests, so operated as to secure our annual lumber cut out of earned interest (new growth) rather than from capital account. The lumber industry in Eastern Canada is not averse to this principle, but it has no inclination to usurp a state function; it has no special call to fix public policy. The state, meaning in this matter, the Provincial Government (or the Dominion Government on Prairie Province lands) is the obvious leader in placing the lumber supply of the provinces on a secure basis. The job does not call for violence, nor confiscation; it calls for an investigation of forest conditions, patient experimental work in devising remedies, and province-wide mandatory application of such new methods of forest operating as may be called for.

#### MAKING PAPER FROM DEAD LEAVES.

Both in Europe and in America there has been a sharp rise in the cost of paper, and this has been peculiarly critical in France. Even before the war France imported half a million tons of paper pulp yearly from Austria and Germany, or about half of the whole amount used. The cutting off of the supplies from the Central Powers, and the severe deforestation due to the

war, have made paper pulp so scarce and so expensive that many periodicals have been forced to suspend publication. It is now proposed to make use of fallen leaves to supply this lack of raw material. M. Edmond Perrier, of the French Academy of Sciences, presented before that body an account of the successful experiments along this line of Madam Karen Dramson.

The process is very simple, rapid and inexpensive; the leaves are first crushed, which reduces the blade to powder, which is carefully separated from the ribs and veins. It is the latter which form the raw material for paper pulp. They are subjected to a somewhat rapid lixiviation and are then washed and bleached, whereafter the pulp is ready for use. The leaf powder which remains is useful in two ways. It has a high food value, since it contains the digestible and nutritious parts of the leaf after the removal of the cellulose. As a food for cattle its nutritious value is almost equal to that of hay, especially when mixed with molasses and compressed into cakes. The leaf powder may also be used as a combustible. For this purpose it may be compressed into briquettes, either with or without being previously mixed with charcoal powder.

Madam Dramson recommends, however, the practice of dry distillation, by means of which she obtained a comparatively pure porous charcoal, rich in calories (6,500 to 7,000 cal.) and easy to agglomerate. The process also yielded an excellent tar, having all the qualities of the so-called Norwegian tar, as well as acetone and pyrolygenous acid. One thousand kilograms of the leaves yielded 250 kilograms of pure carbon (or 500 kilograms of edible powder), 30 kilograms of tar, one kilogram of pyrolygenous acid and 600 grams of acetone. According to a recent estimate by the Director of the School of Grignon, France, produces annually between thirty-five and forty million tons of dead leaves. It is calculated that only four million tons would be required to furnish the paper pulp required in an average year. The economic importance of the question is evident from the fact that in 1913 France paid \$20,000,000 for the paper pulp imported from the Central Powers.

It is believed that the collection of leaves can be done by women, children and war cripples. The leaves can be transported to the paper mills in compressed blocks, but it would be better to build factories on the borders of great forests, so as to eliminate the cost of transportation.

—*Scientific American*.



A new timber raft, built by a Canadian at Hommelvik, Norway, 360 feet long, 42 feet beam, 18 feet deep, which outrode a heavy gale in the North Sea. The possibilities of dispensing with ship bottoms in the transport of timber is engaging the attention of Canadian timber exporters.

## A CANADIAN RAFT DEFIES NORTH SEA GALES

The Department of Trade and Commerce, Ottawa, has received a very interesting statement from Mr. E. Marshall Amsley, a Canadian, who, on behalf of the British Ministry of Shipping, handled the construction of a new design of timber raft at Hommelvik, Norway, and thence made the voyage to Ipswich, England, where it was dismantled. Mr. Marshall discusses the chances of timber rafting as follows:

In reference to the rafting of timber from Hommelvik, Norway, to Ipswich, England, during the winter of 1918-19, a large timber raft was constructed at Hommelvik, Norway, by a London timber firm. As the British Ministry of Shipping was greatly interested in this venture and the arrival of the timber in England being of great importance they gave every aid to help the venture along and to make it a success. I was sent over to Norway last October by the Ministry of Shipping (London) to superintend the construction of the proposed raft. On arrival in Norway I picked out a site for building and also made all arrangements for labor. The raft was built on shipways,

launched, and then towed over to England. I made the trip over the North Sea for the purpose of watching the movements of the raft in heavy seaways. Very rough weather was experienced. However, as the raft "worked" very well, we made the east coast without mishap. I was in charge of the unloading of this raft at Ipswich and was therefore in the position to see the results of the timber having been submerged for three months, and also the amount of damage caused by the movement of timbers during heavy seas.

The raft was 360 feet long, 42 feet beam, and with a depth of 18 feet from top to bottom. The raft consisted of a cargo of 1,242 standards of sawn timber of various dimensions. The raft was constructed something like a ship with a bow and stern, a rudder was used for the purpose of aiding the tugboat to manoeuvre the raft through the winding Norwegian Fjords.

In the construction of the raft a quantity of steel bolts were used for the purpose of strengthening the construction and to give added strength in seaway.

Compressed steel springs were used every ten feet along both sides and down the centre of the raft. These springs would allow the timber to swell without doing any damage to the strength of the construction, also to allow for the working of the raft in a heavy seaway.

When the raft had been completed a tug-boat towed her over to Ipswich, England. The trip over took twenty-eight days, a considerable delay being caused by being held up in the Norwegian Fjords waiting for favorable weather on the North Sea.

During the trip over the North Sea a big storm was encountered. During this storm the raft went through very heavy seas, and she twisted and turned and looked moke like a huge snake than anything else, and it was thought that the raft would never come through. However, the springs served right up to their purpose and allowed the raft to strain itself without doing any material damage. Later when

in quieter waters you would never have known that there had been any strain on the raft.

On arrival at Ipswich the raft was inspected by representatives from the Ministry of Shipping and also by the firm who were responsible for the construction of the raft. Every one expressed their opinion to the effect that it was certainly a wonderful piece of work and a credit to those who had built it.

It took two weeks to unload this timber with the aid of two five-ton electric cranes and a good-sized gang of men.

Most of the timber came out in very good condition and was immediately stacked for the purpose of allowing the sun and wind to dry it out. Some of the timber was rather badly soaked with the salt water. However, as this timber could be used to advantage in foundational work it was not considered that any material damage had been caused by the salt water.

---

## THE WEST DESERVES BETTER THAN THIS!

By J. R. M. in *Toronto World*.

---

Conditions at present obtaining in Canadian timberlands were previously outlined, but criticism is worthless unless followed by a constructive policy. It is my intention to sketch an efficient method of operation in conservation which has been recommended by Canadian forestry experts.

The condition which now prevails in the administration of public timber lands, the experts find, is incongruous; three separate and independently organized government branches divide authority over them. There is the Timber Branch, which is in charge of licensed timber limits; the Forestry Branch, in charge of forest reservations, curtailed, however, by the timber limit within the reservation which had been licensed before such reservations were made; and the Parks Branch, which has charge of still other portions of the timber areas. Each works without organic relation to the other, and even exercising functions and dividing authority over the same territory. Anyone with experience in business will admit that this is not good business.

The Forestry Branch was presumably instituted to bring into the administration technical knowledge which was to be utilized to insure

the continuity of the timber resources in so far as the Dominion controls them. Yet all, or nearly all the timber lands which can be utilized for the next fifty years, under the licenses now supervision. Consequently they are gradually being added to the mismanaged lands which will be the burden of the future. In the matter of commercial timber areas, the division of authority between the timber and forestry branches frequently leads to friction and uneconomic procedure, because the divided authority often covers the same area, namely, where timber limits are included in a forest reserve. This is true in most of the limits in Alberta, and with many elsewhere. Here the Forestry Branch is charged with the duty of protection from trespass for the timber limits themselves as well as outside them, but has no right to interfere with limit-holders who may be liable to trespass, and who may be responsible for fires by neglecting the prescribed conditions of logging and brush disposal. While the conditions in timber licenses as to cutting to a diameter limit, to complete utilization and to leaving the ground in good condition are well taken care of, the personnel of the timber branch being essentially composed of office men, these conditions are most frequently not employed in the field.

## *Abitibi Company Prepares to Handle its Forests Constructively*

Under the direction of Mr. H. G. Schanche, forester, the Abitibi Power and Paper Company, Iroquois Falls, Northern Ontario, are preparing an ambitious programme for the handling of their woodlands and the regenerating of their spruce supply on a scientific basis. The company formed a Forestry Division only this year and has laid out its work under the general heads of: Nursery, Engineering, Protection and Investigation.

The best available site has been selected for a nursery at a point directly east of, and adjacent to, Twin Falls, and here ten acres of land have been cleared and prepared ready for actual operations in the spring of 1920. It is proposed to clear and prepare a similar ten acres annually until a maximum of fifty acres is reached, and here will be developed the source of supply for the reforestation branch. The nursery will be placed on such a basis as to give an annual yield of from one to two million four-year-old trees, but as the first stock grown

from seed will not be available to the reforestation branch until the springs of 1922 and 1923 respectively, it will be necessary to purchase plantable stock of from three to four years in age in order that the reforestation branch may commence operations in the spring of 1920.

The location of the planting sites, together with detailed data on the exposure, slope, soil, ground cover, percentage of natural reproduction and of species present, the drainage, the character and amount of timber standing, the presence of disease or insects which will tend to destroy certain species, the approximate amount of timber standing, the presence of disease or insects which will tend to destroy certain species, the approximate amount of rainfall and snowfall and the fire hazard will all be determined by the engineering branch through an intensive reconnaissance of the limit. This reconnaissance will furnish a full inventory of the forested and barren lands on the limit together with a detailed map. The field data



Using the "planting-board" to plant trees at Grand'Mere, Quebec. The board, consisting of two parallel strips with cross-pieces, is filled with seedlings, which are thus lifted bodily to the trench.



will be secured by a strip valuation survey which will in general convert five per cent of the area of the limit. This data will then be compiled on a map which will show the drainage, the location and extent of timber types, the location of sample plots, the salient topographic features, and the location and extent of possible planting areas. In conjunction with the strip survey an accurate estimate of the standing timber will be carried and the scale used in mapping will be large enough to bring out such details as will prove valuable to future logging operations and to the efficient and economic management of the forest.

Another branch of the department which will make an extensive use of the data and information collected will be that devoted to fire protection. This branch will endeavor to effect the solution, to the greatest degree possible, of the existing fire hazard problems, and will co-operate closely with the Provincial Forestry Branch in developing an efficient organization and system for the protection of the limit against fire.

Still another branch will devote its energies towards the minimizing in so far as possible, of the damages wrought by insects and fungi, and will develop practicable ways and means of preventing the spread of disease and methods of combat.

Through the silviculture branch will be introduced to a fuller extent the more desirable forest species to the exclusion of the less desirable. This branch will protect valuable watersheds and will develop a cutting system which will better the quality of timber, increase its rate of growth, assist and hasten reproduction, reduce windfall to a minimum and produce a maximum final yield by creating the best possible growing conditions for a fully stocked stand.

Comprehensive work of this character will take some time to put into complete operation, but a good start has already been made. The reconnaissance has been begun from a point on the Circle river in Bowyer township, four miles north-west of Low Bush. A crew of men will be engaged on this work throughout the year. A small crew will also follow the logging operations this fall where indications point toward the best harvest in order to collect as much seed as possible. The collection will be supplemented by purchasing seeds of various species and enough will be sown in the spring of 1920 to ensure a final yield of about a million trees which will be available to the reforestation branch for replanting purposes in 1922-1923. From that season on trees in sufficient quantities will be available from the nursery.

## NEW BRUNSWICK'S REGULATIONS

(Issued by the Minister of Lands and Mines of New Brunswick.)

### LOGGING REGULATIONS ON CROWN LANDS.

**Diameter limit**—No sound butted tree smaller than the following diameters measured inside the bark at a point not less than twelve inches from the ground shall be cut: Spruce, white and red pine, twelve inches; princess or jack pine, ten inches. (Penalty fifty cents per tree in addition to regular stumpage.)

No undersize cutting on spruce barrens and slow-growing thickets shall take place without written permission from the Crown Land Office. A charge not exceeding fifty cents per thousand in addition to stumpage will be made to cover cost of supervision.

**Stump height**—All sound butted trees must be cut as low as possible and never higher than sixteen inches regardless of snow conditions. (Penalty, twenty-five cents per tree.)

**Saw to be used**.—The saw shall be used in

falling trees and cutting them into logs; if the axe is used the length for scaling shall be taken from point to point being the extreme length of the log.

**Trimming allowance on logs**.—Six inches over-run in the length of a log shall be the maximum allowance made for trimming; if this is exceeded the log will be scaled as one foot longer.

**Size of tops**.—All tops shall be taken out to as low a diameter as possible. Spruce tops 6 inches in diameter is the maximum allowed except in case of very bushy top, when 7 inches will be allowed. Fir 6 inch top is the maximum allowed. White and red pine 7 inch top is the maximum allowed. (Penalty \$7.50 per thousand feet.)

**Mixing logs**.—Logs cut on Crown Lands shall be placed in separate brows from those cut on

Granted lands and shall be marked with a different mark.

Skids, roads, bridges, camps, hovels.—No spruce, white or red pine shall be used as skids or in the building of roads or bridges where other species are available. Where soft wood must be used fir must be taken in preference to spruce. (Penalty, \$7.50 per thousand feet.)

Trees wholly killed by spruce bud worm or fire must be yarded and browed separately from living trees in order to obtain the two-thirds rate of stumpage; otherwise the full rate will be charged.

Lodged and burned trees and windfalls.—All

lodged trees, all spruce and white and red pine necessarily cut out of roads, yards, landings, etc., and any dead, burnt or blown down trees suitable for lumber shall be taken out. (Penalty \$7.50 per thousand feet.)

Protect young growth.—All reasonable care must be taken to prevent injury to young spruce trees below the diameter limit.

Game protection.—Scalers are sworn to report all violations of the Game Laws coming under their notice.

E. E. SMITH, *Minister of Lands and Mines*  
Crown Land Office, 1st Oct., 1919.

## QUEBEC LOGGING SLASH A GREAT MENACE

By *Henry Sorgius, Manager,*  
*St. Maurice Forest Protective Association.*

The fire season of 1919 was without doubt the driest season we have experienced in the St. Maurice Valley of Quebec since the formation of the St. Maurice Forest Protective Association. In fact old bushmen of this region claim that not since 35 years have they had such drought accompanied with heavy winds.

So far our records show that 160 fires have occurred in our territory; of these two got away from us and burned over large areas. One was caused by a locomotive throwing sparks and the other was caused by dam-keepers. Both fires were reached by our rangers before they had made any headway. The one at Vandry when rangers discovered same was about 25 feet square, and they could not handle it on account of the debris caused by lumbering and the heavy winds prevailing at that moment. The assistance of 12 men was obtained inside of 30 minutes, but when they reached the scene of the fire the area burned over was more than a mile and early the next morning we had more than two hundred men at the fire, but extinguishing it was almost impossible on account of the logging slash. We could only delay the fire until rain came. This fire burned about 25 square miles, practically all in cut-over land.

The second fire was discovered when it had only burned over about an acre and before 30 minutes a crew of about 60 men was at the scene and we had over 200 men at the fire early the next morning but, as in the previous-mentioned fire, we could only delay the progress until rain came on account of the existing logging debris and the heavy winds prevailing at that moment. This fire burned over land. It is a known fact that when a fire once gets started in logging slash it is almost impos-

sible to extinguish it without the aid of rain. The men have no chance whatever to work on account of the tree tops lying on the ground and the speed with which the fire travels in this debris renders the work more or less dangerous.

The writer is convinced that if it had not been for the logging slash neither one of these fires would have caused any damage or expense as the rangers could easily extinguish said fires at the time that they were discovered, if they had started in any other place than among the logging debris.

Out of the 160 fires which have occurred, 57 per cent of these were caused by the railroad and 10 per cent by the employees of the different companies such as log drivers, dam keepers and explorers, not one fire was caused by the settlers, which goes to prove that the best method to be used in forest protection is the educational campaign, as shown by our work done throughout the settled districts which has been crowned by success.

The writer would strongly suggest that the only method to be used to save our valuable forests is to prevent fires and this can be done in our territory by educating the people travelling through our forest and also by having the railway right of way and a strip adjoining this right of way properly cleaned every year.

The bushman can be educated to prevent forest fires as easily as the settler, but this means a little work, time, money and co-operation.

The writer would suggest that all railways traversing timbered sections should burn oil instead of coal.

The laws in regard to forest protection of this province are as good as we want them in as far as the St. Maurice Valley is concerned.

## *Learning How Pine Tree Crops Can Be Ensured*

The accompanying photographs illustrate the methods of developing "sample plots" on the Petawawa Forest Reserve under direction of the Dominion Forestry Branch.

As described in recent issues of the Canadian Forestry Journal, the purpose of these plots is to investigate the natural reproduction of white pine and red pine chiefly and to ascertain the effects of various silvicultural methods on the production of wood increment. The studies have great economic value, particularly to the pine lumbering industry of Eastern Canada.

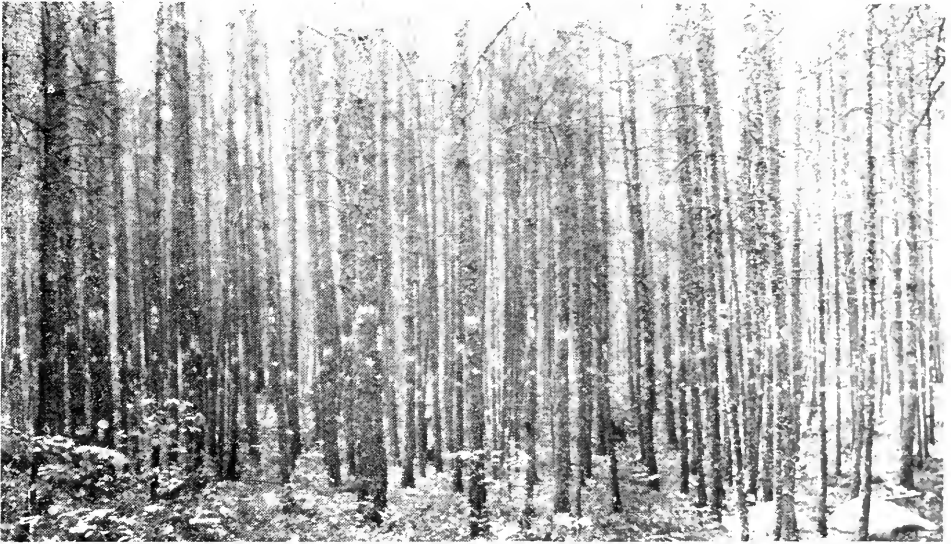

A sample plot at Petawawa before being thinned out.



A sample forest plot before the thinning process has been carried out. The trees have already been cleaned of their dead branches.



The thinning of a sample plot has as its object the improvement of the stand. The smaller and least valuable trees are cleaned out so as to produce more favorable growing conditions for the remainder. The picture shows a plot at Petawawa with thinning completed.



Working on the sample plots at Petawawa. Left to right: Lieut. D. A. Macdonald, A. H. D. Ross (a visitor), Frank Reynolds, Neil Chrystal (entomologist), H. Horton, H. C. Wallin. Seated: F. T. Jenkins and Captain A. Bentley.

## PRAIRIE PROVINCES AND THEIR NATURAL ASSETS

The Secretary of the Canadian Forestry Association, Mr. Robson Black, recently concluded a visit to Manitoba, Saskatchewan, and Alberta, during which thirty public meetings were held in order to develop public vigilance in the better conservation of the forest wealth of the Prairie Provinces and to discuss with western business interests a more intensive educational campaign to encourage shelter-belt planting around prairie farms and homes. In many cities three meetings daily were in progress.

The western newspapers devoted abundant space to interviews and reports of addresses so that the propaganda actually reached a very large number of people.

The chief object of the addresses was to tie down the forest conservation question to local western interests and to identify the present impoverished condition of the Prairie Province forests as a threat to future industrial development, the safety of stream flow and irrigation, and a cheap wood supply to incoming settlers in the northern districts. The speaker endeavored to outline a constructive plan of fire prevention and timberland management, keeping in view that the west may soon control a part of its forest resources and that now is the time to stimulate public sentiment and establish a correct theory of provincial administration.

The attendance at the meetings was, with few exceptions, remarkably good. Such bodies as the bankers and mortgage companies, the Rotary Clubs, Canadian Credit Men's Association, Canadian Clubs, Universities, Normal Schools, etc., organized special meetings for the convenience of the Canadian Forestry Association, and strong pledges of support were given.

### PROVINCIAL COUNCILS FORMING.

To more or less identify the provincial governments and leading business men with the forest conservation cause, the Secretary undertook to form Provincial Councils for each of the Prairie Provinces, with the Premier, one of his ministers, and the leader of the Opposition

joining with ten of the strongest business men of the province, to co-operate in extending our educational work.

It is an interesting fact that while such cities as Winnipeg, Regina, Calgary and Edmonton are commonly regarded as being rather aloof from forestry worries, Winnipeg actually has over one thousand members in the Canadian Forestry Association, and thereby ranks second only to the city of Montreal as a focal point of forestry conviction in the Dominion. There is also a large membership in Calgary and Edmonton, and there seems a good probability that during 1920 the strength of the Association between Winnipeg and the Rocky Mountains will run into several thousands.

The western work of the Association not only in the Prairie Provinces, but in British Columbia urgently requires the appointment of a Resident Western Secretary who will be in constant touch with the local membership and able to promote the objects of the Association in an intensive educational way.

### SEE IT AS A BUSINESS MATTER.

The business men of Western Canada are keen to take up cudgels for more efficient administrative policies as affect the handling of the natural resources. In no part of the Dominion, except perhaps Nova Scotia, have the forests suffered to such an extent as marks the tremendous expanses across the northern sections of Manitoba, Saskatchewan and Alberta. In the old days when a public-owned asset was often regarded as beyond the personal responsibility of busy citizens, public administrators were seldom called upon to account for such items of needless public waste as this year's forest fires in Northern Saskatchewan, totalling over eight million dollars of absolute public loss. To-day, however, the western citizen evinces a refreshing intimacy with the economic consequences of destructive management of the natural resources and is eager to play his part as a citizen in bringing about reforms.

## BRITISH COLUMBIA LOSES A MILLION DOLLARS

Victoria, B.C., Sept. 30, 1919.  
Our patrol forces, 180; acreage burned, 160,000; number of fires, 400; green timber loss, 17 million feet board measure; fire loss,

camp, engines and timber sawmills, \$900,000. Prosecutions and convictions, 16.

M. A. GRAINGER,  
*Chief Forester.*

## ON THE EXHIBITION CAR IN ONTARIO

By J. R. Dickson, B.A., M.S.F.

The Exhibition Car of the Canadian Forestry Association, which made a most successful debut as a propaganda agent in 1918, when it was taken through parts of Quebec and New Brunswick, has through the interest and courtesy of the railways again been sent forth to continue its good work of spreading the gospel of forest conservation.

At midsummer this car was placed in my charge and with an assistant to run the moving picture machine, I left for a three weeks' trip through Northern Ontario, going as far west as Kenora and as far north as Cochrane. We visited en route some twenty towns and cities, stopping at each place about a day and wherever possible holding an evening lecture.

### GREAT PUBLIC INTEREST.

The keen interest which we found nearly everywhere was most encouraging and shows that this vitally important question of securing better protection and better management for our timberland heritage is steadily strengthening its appeal among all classes of our citizens. For instance, North Bay, a railway centre; Port Arthur, a great lumber depot; Dryden, a Kraft paper fame; and Timmis, the gold mining centre; to mention only four places, each furnished an enquiring throng of 500 to 1,000 car visitors and at a number of evening meetings, the accommodation was taxed to the utmost. It is only fair to say, however, that the potent lure of "the movies" drew crowds of children to these meetings, and although this mixing of kiddies and adults makes a difficult audience to deal with, the boys and girls were always welcomed as potential citizens and a special attempt made to explain the meaning of conservation and to enlist their sympathy and interest.

On entering the car, the first thing to engage the visitor's eye was a map of Canada, showing as a green band from coast to coast, this country's great "tree farm" of some 400,000,000 acres. The average visitor showed a growing sense of interest when it was pointed out that the title to practically all this absolute forest land was still held in the name of the people, giving some 50 acres on the average to every man, woman and child in Canada. The remarkable fact that since the days of the French Régime our policy in general has been to lease

and not sell our timberland, is what makes it worth while to-day to send out this car to educate public opinion. In the United States, where an ultra laissez-faire policy so foolishly sold outright 80 per cent of the national timberland, they are becoming more and more alarmed about the future, and more and more envious of Canada's unique opportunity in this respect.

Some lumbermen are fond of telling how they can return again and again to their limits for another cutting, but none the less a constant forest depreciation is going on in Ontario both in quality and quantity. I was on a berth near Cobalt where the first cutting was largely white pine, the next largely red pine, the next, and most recent one, largely spruce, the next ensuing one promises to be largely jack pine and the one after largely weed trees or nothing. Ontario people are at last awakening to the fact that it is absurd to have only two or three foresters looking after a 200,000-square mile tree farm when they should have two or three hundred foresters. Quite outside of guaranteeing the many auxiliary forest benefits, such as the maple sugar industry, the fur trade, the hunting and fishing, the enormously valuable summer tourist possibilities, the hydro-electric energy, an unfailing domestic water supply, and the beneficial climatic influences, it would pay well for the primary purpose of securing future log and pulpwood supplies, to properly manage our timberlands, for man can grow 5 to 10 times as much valuable timber per acre as is now being produced by nature on our cut-over areas.

### ONTARIO HAS MUCH AT STAKE.

The abundant production of wood is vitally necessary to safeguard the future of our two thousand wood using concerns in Ontario. By showing a few of the hundreds of essential uses of wood, the car exhibit clearly indicated how nearly every industry is keyed into the forest. To see products as widely different as sugar and vinegar, candy flavors and powerful poisons, fibre silks and imitation iron, all made from wood, is an impressive method of education. Although as yet we manufacture in the main only two pulp products—newsprint and kraft paper—Canada's export pulp and paper business has grown in twenty-five years from \$100 to \$100,000,000 per annum, and about one-

half of this increase occurred during the past two years. In war time, wood is essential for certain war-winning factors like high explosives, black gunpowder, gas-masks, and aeroplanes. In brief, the forest has become the basis of our safety in war and prosperity in peace.

What is Ontario doing to protect and develop this invaluable resource? The Settlers' Fire Permit law of 1917 was an important step toward forest conservation and is working out well in practice. The reorganization of the fire ranging force, with closer supervision, has also had fine results in largely increasing its relative efficiency. Moreover the rangers are now being equipped with abundant supplies of fire-fighting apparatus, and the construction of permanent improvements such as trails, telephone lines and lookout towers is being undertaken. Finally, the Government in conjunction with the Federal Conservation Commission plans to start this fall on a general stock-taking of Ontario's standing timber together with a classification of the land in order to determine roughly what areas should be devoted to farming and what to forestry.

#### LUMBERMEN AGREE.

All of which is excellent and necessary, but it still leaves untouched the basic questions of slash disposal and proper providing of seed trees. While on tour we met one superintendent, two inspectors, three chief rangers, and many rangers, of the Ontario patrol force and they were a unit in regard to the urgent necessity for a law requiring logging slash to be promptly burned, i.e., at time of felling if feasible, and in any case during the succeeding winter or spring. For instance, the Inspector at Sudbury said it was emphatically his opinion that unless all forest users were at once obliged by law to pile and burn their brush it would be impossible to save the remnant of our forests. Furthermore, it is worthy of note that at Temiscaming, North Bay, Chapleau, Port Arthur, Dryden, Iroquois, and elsewhere the car was visited by prominent lumbermen and paper-makers who without exception agreed to the reasonableness and soundness of the arguments advanced by the Canadian Forestry Association

--both as to slash disposal and forest renewal. They admit the deplorable wood butchery which springs from our Canadian practice of so generally entrusting the cutting operations to contractors and sub-contractors of a tenant! We must have better legislation to change such practices in Ontario and I believe the licensed lumbermen themselves would welcome its appearance. No hardship can result if the new requirements are impartially applied to all forest users.

#### REAL VALUES ARE LOST.

Again, the ordinary operator cutting under a mere blanket regulation recognizes no difference between the life history (and therefore the silvical requirements) of a spruce and a jack-pine. We must get enough science into our spruce harvesting to have this favored species reproduce itself instead of all blowing down. The whole problem calls for good-will, common-sense, co-operation and science.

The old futile idea of blaming the operating lumberman for existing conditions in our forests is out of date. He is a useful citizen whose enterprise provides employment for countless thousands of his fellowmen, and with spruce at \$40 per M. he is not making as much money as when the price was \$15 to \$20. The Forestry Association is seeking to educate the average citizen up to the point of seeing that the owner of the land is really the predominant partner in the community of interests, exploiting our forest resource; to see that in the long run the public get several dollars for each dollar the lumberman does; to see to it above all, that their solemn trusteeship of the rights of all future Canadians is more fully acknowledged and honored. Such a "community spirit" is growing rapidly, as witness the quadrupling of the Canadian Forestry Association membership during the past four years. Conservation cannot be practiced in spots, it must be general to be effective. This requires a uniform law which in turn is the creation of an educated public opinion.

To develop such an informed public opinion is the sole object and mission of the Forestry Exhibition Car.

## NEW ZEALAND'S WASTED TREASURE-HOUSE

*By D. E. Hutchins.*

The New Zealand forests have never been surveyed, and only vague estimates have been made of their area and stand of timber. The working of the sawmills, however, shows that the outturn of sawn timber over the area milled has averaged about 1,500 superficial feet per acre (a superficial foot equals 12 inches by 12 inches by 1 inch). If one compares this figure with the average stand of timber throughout the forests of the United States of America, it will be seen that the New Zealand figure is two-and-a-half times the average timber-stand of the original virgin forest of America, and over three times that of the present American forests. Exceptionally, and over small areas, timber-stands in New Zealand up to 200,000 superficial feet per acre have been recorded.

In quality, New Zealand timbers come before those of Europe and Australia, and after those of North America. The value of kauri timber is well known, but it is not generally known that kauri is the record largest timber-producing tree

in the world. There are trees that are taller and somewhat thicker, but the bole of kauri bulks the largest on account of its having little or no taper. The massive columnar shape of the tree has struck all observers from Charles Darwin onwards. There was at one time about three million acres of kauri forest in New Zealand; very little is now left, but there are about half a million acres of restorable kauri forest. It is calculated that this, if restored, would pay all the cost of the great war to the next generation or their children.

In spite of their value, the New Zealand forests have had a sad history. The early pioneers came from a country where state forestry was unknown, but where there was enough wealth to pay huge sums yearly for imported timber—£43,000,000 the year before the outbreak of war. The early colonists knew nothing of forestry of any other country than England, and they were thrown entirely on their own resources. They had to destroy the forests to live!

## PRAIRIE TREE-PLANTING AND DROUGHT

Forestry Branch, Nursery Station,  
Indian Head, Sask., Sept. 27, 1919.

To Canadian Forestry Association, Ottawa:

In reference to a more active campaign in the drier districts of southern Saskatchewan and Alberta with the idea of developing public interest in tree-planting, I might say that so far as the present work of the nursery is concerned we practically turn out all the stock that we possibly can. If a much greater demand was created we would not be able to handle it with our present resources. The question of tree-planting in these dry districts will be a very difficult problem. As you can easily realize, where there is not sufficient rainfall even to germinate wheat and mature the grain crop, it is practically impossible to grow trees success-

fully under the same conditions. I do not see myself that tree-planting in itself will be any remedy against these recurring drought periods. It appears to me that the only solution of the problem will be to have a much further development of the irrigation schemes if it is possible to work them out practically. If water can be secured sufficient for ordinary agricultural purposes there would be then no difficulty whatever in establishing successful plantations, but it is quite impossible to expect any general results from tree-planting in districts where there is not sufficient moisture in the soil to carry the young plants through until they can become properly established.

NORMAN M. ROSS,  
*Chief of Tree-Planting Division.*



## CAN GERMANY PAY FOR FOREST VANDALISM?

By M. Huffel, in "*Revue des Eaux et Forêts.*"

The long war from which we are emerging has terribly tried our French forests, formerly so rich and beautiful. The fellings made for the needs of the army, those made with incredible vandalism by the enemy in the parts he occupied, which were precisely the best wooded in the country, have impoverished and ruined them for a long period. As to the woods situated in the region of the front, there remains too often nothing but a mere vestige of them.

The damage done to our forests cannot immediately be restored by spending money. A house may be rebuilt, a factory can be provided again with the essentials in a few years; to reconstitute a forest there is required not only money, but time. Our forests will not be re-established at their past degree of high value within a century.

This situation is the more disquieting because it is precisely at this moment, when the sources of wood production are so much reduced, that our needs have enormously increased. We have to rebuild our houses and to replace our furniture and appliances. It will be absolutely necessary to take from the forests of the enemy what we need, and which he owes us, to replace what the war has caused us to lose. My object is to work out, as far as possible, what the enemy's forest resources are, and how we may utilize them.

From official statistics of 1900 the total wooded surface of the German Empire (omitting Alsace-Lorraine) was 13,556,037 hectares (1 hectare equals 2.47 acres). The species were as follows: Broad-leaved species of various kinds—among which oak high-forest occupies 5.2 per cent of the total wooded area—cover 26.7 per cent of the area; conifers occupy 73.7 per cent (46.6 per cent Scots pine, 24.6 per cent spruce, 2 per cent silver fir).

If we consider specially the State forests we obtain a total of 338 million cubic metres (11,938,160,000 cubic feet) of timber available in the German State forests, of which 183 is in wood of over 100 years, 85 in wood of from 81 to 100 years, and 70 in wood of from 61 to 80 years. More than a third of this enormous amount of material is Scots pine, which will furnish excellent timber for rebuilding the houses destroyed by the vandal boche. A quar-

ter, in beech, will give good carpentry material. The spruce and silver fir will yield 3 milliards of good planks, which will come in very handy for our needs and to the relief of our own conifer forests. The oak, too, will be very welcome for our cabinet-makers, who are in danger of failing to obtain this first-class material from our own woods, impoverished, ruined and destroyed as they are by the war.

Is it possible to exploit this mass of wood of which I have just given an idea? Is it morally, that is to say, equitably, possible, and is it materially possible? This it remains to me to examine.

The war has impoverished all our forests; it has ruined many of them, and it has, alas, totally destroyed a too large number in the zone of the operations. The enemy is responsible for all this—for what was used in the waging of the war, and for what was destroyed by him in a spirit of shameful vandalism. It was he who brought about the war in order to assure the domination of the universe by Germany: "Deutschland, Deutschland uber alles, uber alles in der Welt."

The ruin of houses, the destruction of furniture and implements can be compensated in money; forest produce can only be replaced in kind. We shall not find in the open world-market the wherewithal to replace what we have lost. Our forests will not recover their old capacity of production within a century. We must, therefore, make the enemy pay us in kind, that we may be enabled to properly manage our improvised forests on the one hand, and on the other that we may reconstruct our appliances and rebuild our houses.

The exploitation of the wooded capital of the public German forests will not be an act of vengeance, but of restitution and reparation. It will be still less an act of spiteful hate, like that which was done by the barbarous boche, the son of the Huns and Vandals, when he broke with hammers the sewing-machine of the seamstress, and destroyed the trade of the weaver, when he rendered useless the plough and the thrasher, when he sawed down the fruit trees in the orchards. We may in all conscience accomplish an act of restitution, of reparation and of justice in exploiting the public German forests.

## GUELPH PLANTS TO SAVE WATER SUPPLY

Guelph, Ontario, is a tree-planting municipality. It has 300 acres of civic plantations on the watershed of the streams that supply the city. Writing to the Forestry Journal, Mayor J. E. Carter states:

We have done a large amount of tree-planting on the Waterworks property, situated 5 miles from the city, near Arkell. The city owns a considerable tract of land, around 300 acres on which the springs which supply the city with water are located.

About seven or eight years ago the city reforested nearly all this property. They were

very successful, the trees practically all growing; that is a large percentage. We had a large area of the old swamp burned during the dry part of this summer. We intend to reforest this next spring, and also our sewerage farm of about 25 acres.

The idea that first made the city reforest the waterworks property was to conserve the water supply, and although the past summer has been very dry, in fact one of the driest in the history, our supply of water has increased over any former year.

---

### TREES FOR THE HOLY LAND.

Two principal recommendations which a civilian commission now in Palestine will make relative to the reconstruction of that country will be a scheme for beginning afforestation and a proposal for the conservation of water supply by storage and by opening up old springs.

The greatest of all Palestine's needs is afforestation. For centuries the land has been denuded of its trees, with most disastrous consequences, for the heavy rains at certain seasons, instead of benefiting the soil over more than four-fifths of the area carry away in rushing torrents much of the little soil that remains on the high lands and valley slopes.

Palestine has not always been treeless. The Roman Emperors had valuable forests in the country, and Absalom, riding, was caught by the hair among the trees, but to-day one might gallop from Dan to Beersheba without having to duck one's head to avoid a branch.

—*Australian Forestry Journal.*

---

### WHY FORESTS ARE PETERING OUT.

Statistics compiled by the United States Forest Service, in co-operation with the National Lumber Manufacturers' Association show the lumber cut in the United States in 1918 was 29,362,020,000 feet. These figures are based on reports of 14,753 mills up to June 15. The computed cut for the past year is 11 per

cent smaller than the 1917 production, due largely to economic conditions during the war and in the wake of the armistice. The computed total cut of 1918, based on the assumed operation of 22,546 mills, is 31,890,494,000 feet.

There is only one instance of increased cut cited, namely in Oregon and Washington, where a 2 per cent gain is reported. The latest statistics indicate a 20 per cent slump in production in the yellow pine group of states. The North Carolina pine group decreased the cut by 19 per cent, while the lake states fell off only 9 per cent.

The heaviest cut reported was yellow pine, which amounted to 9,941,997,000 feet, and the computed quantity 10,845,000,000 feet. It is apparent that the reported quantity of Douglas fir, the next in amount of production, is almost complete, as advices give the cut at 5,819,141,000, and the computed quantity 5,820,000,000 feet. The statistics show 1,968,477,000 feet of white pine have been reported, and 2,220,000,000 feet computed. Oak ranks fourth in order of cut, having 1,658,714,000 feet reported and 2,025,000,000 computed, slightly higher than white pine. Hemlock cut, as reported, amounts to 1,696,493,000 feet, with 1,875,000,000 feet computed. The cut of western yellow pine reported is 1,707,784,000 feet, with 1,710,000,000 feet computed.—*Pacific Coast Lumberman.*

## THE SAMPLE PLOTS AT PETAWAWA

The Dominion Forestry Branch has, during the past season continued the investigative work at the Forest Experiment Station on the military reservation at Petawawa, Ontario. A number of permanent sample plots have been established, mapped, and described, and much interesting and useful information in regard to growth, yield, stem-form, and habits of certain species under various conditions, has been collected. Some plots have been thinned for experimental purposes. The trees on the plots are carefully measured, numbered, and classified according to crown-class, and the position they occupy in the stand. The exact location of the remaining trees, as well as of the ones thinned out, is shown on a map. It is the intention to study through repeated measurements and observations, at intervals of three to five years, the future development of the trees on the plots. Plots have also been laid out on logged-over areas with the object of studying reproduction.

The Petawawa military reservation is an excellent site for silvical and silvicultural investigations and experiments, especially with reference to young forest. It contains within its limits many forest types, permanent and temporary, that are representative of large sections of Ontario and Quebec, which have been logged over from thirty to fifty years ago, and which have had their usual share of repeated fires.

A thorough study of the habits of the different species, under various conditions; of the mutual relation of soils and plant life; of reproduction; of growth and yield, etc., combined with experiments with different silvicultural methods of planting, thinning, cutting, etc., on this area will, no doubt, in time, result in much knowledge being obtained which will be of great benefit to lumbermen and owners of forest land in general.

The investigations at Petawawa were carried on under the supervision of Mr. H. Claughton-Wallin, assisted by Forest Assistant (Flight-Lieut.) D. A. Macdonald, Captain A. Bentley, M.C. (University of Toronto), Mr. H. Horton (University of Toronto), Mr. John Irwin (Uni-

versity of Toronto), Mr. E. T. Jenkins, R.S. (University of Toronto), and one or two local returned soldiers.

Mr. N. Chrystal spent some time with the party on behalf of the Dominion Entomological Branch, and Mr. Wallin also reports very pleasant visits being received from Mr. Arthur Graham, chief fire inspector, Ottawa River Forest Protective Association, and Mr. A. H. D. Ross, formerly of the staff of the Faculty of Forestry, University of Toronto.

### TREES FOR MEMORIAL PLANTINGS



Special quotations on quantity lots of  
Shade Trees, Weepers, Evergreens, etc.

*Send for Catalogue.*

**STONE & WELLINGTON**

The Fonthill Nurseries

TORONTO

ONTARIO

## PUTTING BACK A NEW FOREST

*By Ellwood Wilson, Chief Forester of the Laurentide Co.*

Wood is the raw material entering most largely into the manufacture of newsprint paper. Various substitutes have been tried, but so far none have been very successful or seem at all likely to supplant wood, and it is not likely that anything else will ever do so to any large extent. The cellulose in wood, which is the fiber from which the paper is made, is in such a compact form that it can be easily transported and stored. If cornstalks, cotton stalks, or grasses were to be used in the manufacture of newsprint, the huge bulk to be transported, the large areas which would have to be covered to get sufficient material, and the difficulty of storage, owing to the decomposition of the material would be very serious and costly obstacles. The woods most commonly used are spruce and balsam fir, both trees which grow in cold climates or at moderately high altitudes, so that they are often in the neighborhood of large rivers with many falls which furnish the cheap transport by driving and the cheap power for manufacture, which are so essential to paper making. Spruce is preferred somewhat to balsam fir, as the fibers are a trifle longer and the wood is said to "cook" more easily in the digesting process used for disintegrating the wood and removing other substances than cellulose which it contains.

### HOW THE FOREST IS REDUCED.

Spruce and fir are almost always associated in the northern forests and are often mixed with the native hardwoods. Under the conditions of competition with other species in the virgin of wild forest they grow on an average of about one inch in diameter in ten years, but when grown in the open, as on abandoned farm lands or after a fire has destroyed a forest they grow under the rate of about one inch in four to six years and in very favorable circumstances as in plantations with proper spacing, they will grow one inch in two to three years. The average amount of wood which is cut on lands under license from the Government in the Province of Quebec according to the Government regulations is between six and seven cords to the acre. As it takes approximately one cord of wood to make one ton of paper, a mill with an output of 100 tons per day would have to cut about eight square miles of forest every year.

The most important matter for a paper mill

is the supply of raw material for the future, and this is taken care of generally to-day by acquiring sufficient areas of forest land to insure the supply. Mills which have not already done this find it difficult, as practically all the readily accessible lands have been sold. Many of the largest and most progressive companies have already begun to plant trees for future use or are getting ready to do so. This is much the better way to handle the problem, as the plantations can be made on lands much nearer to the mills, thus reducing the cost of fire protection and transportation, and as the yield on planted lands is at least ten times that on wild lands, the logging expenses are more concentrated and therefore much reduced.

### QUEBEC'S FIRE PREVENTION.

Fire protection for forests is a most important thing, and since the formation of the cooperative fire protective associations the loss from fire has been reduced to almost a negligible amount. The forests are patrolled by men in canoes, on horseback, on motor cycles, and in automobiles, and patrol by aeroplane has recently been adopted. Gasoline pumps are used for extinguishing fires and the organizations have been brought to a high pitch of efficiency.

After fire protection, the most important thing a forester has to do is to make accurate maps and estimates of the amount of timber. This is necessary so that it may be known how long the timber holdings of a company will supply the mill, where and how they are located, and how they can be cut most economically and to the best advantage. The logging departments must have maps in order to plan their operations from year to year intelligently.

Logging operations usually begin in the latter part of August, when the contractors who cut the logs go into the forests, taking often their wives and families with them. Here they build camps of logs, roofed either with split logs or tarred paper, and the cracks of the logs are stuffed with moss. These camps, although differing in size, are all built on the same plan. They are oblong with a door in front, two or three small windows, a rough table, and a few benches and bunks for sleeping along one wall, generally in two tiers. A large stove in the centre is used for both cooking and heating. If the wife lives in the camp a small room is

built at one side; sometimes only a curtained enclosure is provided. The stable is built at one side, often with an opening into the camp to give warmth for the horse. The trees are cut and sawed, the branches cut off, and then they are sawed into logs, usually  $1\frac{3}{2}$  feet in length and dragged out or "skidded" into piles, which are made alongside the roads which will take them to the nearest river or lake. When the snow is deep enough to make hauling easy the yare "landed" or piled on the shore or sometimes on the ice. Here they are measured by the "culler," and the jobber or contractor is paid by the thousand feet board measure. The hauling is usually finished by March 1st, when the woodmen return to their homes.

#### THE LOG JAM.

As soon as the ice is out of the lakes and rivers the "drive" commences. Logs which are piled on the banks are rolled into the water and start on their way to the mills. The drivers keep them from lodging on the banks or in rapids and follow after the main body of the logs, rolling back into the water such as have become stranded. Often the logs stick on the rocks in the rivers, and large piles or jams are formed. Then the dangerous part of the work commences. The boldest men in the crew get out on the pile and try to loosen the log or logs which form the key of the jam. This takes skill and courage, for when the jam is loosened it may go quickly and the men must not get caught. Sometimes dynamite must be used to dislodge the jam. On small streams dams are built to hold back the water which is let out as needed to supply enough water for floating the

logs. When the logs are cut each owner stamps his mark on the end of the log and cuts a bark number into the log near each end. On arrival at the mills the logs belonging to it are sorted out and taken up out of the water to be utilized.

#### HOW THE NURSERIES GROW.

The more progressive companies have established nurseries and are reforesting their lands. A nursery is like a garden, the tree seeds which are collected in the fall and which are, for the spruces and firs, about as big as turnip seeds, are planted early in the spring and germinate in about two weeks. The little trees, which grow slowly, are two to three inches high at the end of the first season, and after they first come through the ground must be shaded by frames, usually made of laths, for about two months. They must also have water during dry spells and be kept free of weeds. By the end of the second season they are four to six inches in height and at the beginning of the third are transplanted in long rows and kept cultivated and free from weeds until the end of the fourth year, when they are planted out in the forest. They are then about twelve inches high. They are usually planted five to six feet apart and are carefully protected from fire. When they reach four to six inches in diameter they may be somewhat thinned out and from then, till it is decided to cut them all, thinnings are made about every ten years, depending on the rate of growth. In thinning the weakest and poorest trees are removed so as to allow the best and strongest to mature. To form a spruce forest about 1,200 to 1,700 per acre are planted.

---

## THE IRRIGATION FARMER FEELS THIS BILL

---

At many of the meetings of the Canadian Forestry Association in the Western Provinces during October, the following telegram from Col. J. S. Dennis, Chief Commissioner of Colonization and Immigration of the Canadian Pacific Railway, was read. Col. Dennis, who is an ex-president of the Forestry Association, sent the message at the Secretary's request:

"The destruction of timber on the eastern slope of the Rocky Mountains and on other drainage areas in the west through fire is a serious menace to the successful operation of existing irrigation systems or their extension in southern Alberta or southern Saskatchewan,

and in the continued supply of water in drainage channels for stock watering. This is due to the fact that when timber and underbrush on drainage areas are destroyed the run-off from these areas is lost through floods with incidental damage, at periods of the year when it should be given off slowly to be of use for irrigation or stock watering.

"In my opinion one of the most important matters in the west to-day is to make every effort to prevent destruction of timber on our timbered areas through forest fires.

"J. S. DENNIS."

## THE TAP-ROOT OF FIRE TROUBLES

Of the forest fires on the areas of the Laurentian Forest Protective Association (Quebec) this year, 40 per cent of the area burned was "slash land" and about 30 per cent of the fires occurred in old or recent burns.

Fires burning in these areas are invariably extremely fierce and in some cases they die out very late in the night or early in the morning; thus the time available to fight them is much

shorter than in the case of fires which occur on timbered areas.

To the end of September, the "Laurentian" territory recorded 24 fires in May, 25 in June, 13 in July, 2 in August, and 2 in September. As to causes, 35 were scored against "unknown," 16 to settlers, 6 railway, 3 lightning, 5 lumbering, 1 "other causes."

## FIRES SOUTH OF THE ST. LAWRENCE

Good work again is recorded by the Southern St. Lawrence Forest Protective Association. Particulars sent in by Mr. Brule, eastern manager, state that a total of 732 fires were extinguished by the 15th of September. Ninety per cent of the fires were caused by settlers' slashings. Twenty-two prosecutions resulted, and twenty convictions secured. In most cases, however, the culprit was let go with minimum fine and costs.

Most of the fires which got out of control and necessitated extra help were fires which spread into logging slash of one, two, or three years' old. Logging made before that period seems not to offer any danger for forest fire. It would certainly be desirable that some experiments be carried on in the burning of the logging debris in actual cuttings. Although the cost of such operation may be quoted high, I am inclined to think that the abatement of danger and dam-

ages made from that source would sufficiently compensate. It is expected that experiments along this line will be made in some sections of Quebec forests in the course of the present lumbering operations.

"I may add in conclusion, that we had also trouble in procuring assistance for fighting forest fires in different instances, and that, for pretexts of small importance. Farmers and settlers during fire season are always more or less busy working on their farms or lots, and it is always a problem to have them fighting fires, a kind of work they dislike very much. For some of them the salary we pay (\$2 per day) is not sufficient; others always find some excuse. **Lack of education seems to be the whole cause of such trouble.** A good educational campaign in that sense is felt and that only will solve the difficulty, and the result would certainly be of some benefit to all."

## SETTLERS MUST BE WON OVER

Mr. C. B. Guerin, manager of the Western Division of the Southern St. Lawrence Forest Protective Association, writes:

Our present object is to educate the public concerning the protection of forests from fires, and to attain this end, it is essential that the settlers comply with the law, for we know by experience that settlers who burn their slash with permits take greater precautions than those who have no permits.

According to the information furnished by our fire wardens, it may be asserted that 33 per cent of the settlers who burned their slashes without permits caused damages to the forest, while only 6 per cent of those who burned under permits caused damage to the neighboring properties.

It is, therefore, important to continue our campaign in favor of permits, if we wish to control all fires started in our territory, for all the forests belonging to our members are adjoining farmers' lands.

In Mr. Guerin's division, south of the St. Lawrence, in Quebec, there were 15 fires in May, 40 in June, 8 in July, 7 in August, and 1 in September, a total of 71. As to causes, 10 were "unknown," 3 due to campers, 23 to settlers, 34 to railways, and 1 incendiary. Mr. Guerin estimates the area of association lands burned over at 144 acres, and 1,555 acres of non-association lands. Of the 144 acres of association lands, 134 acres were slash covered.

# Northern Electric

## POWER AND LIGHT

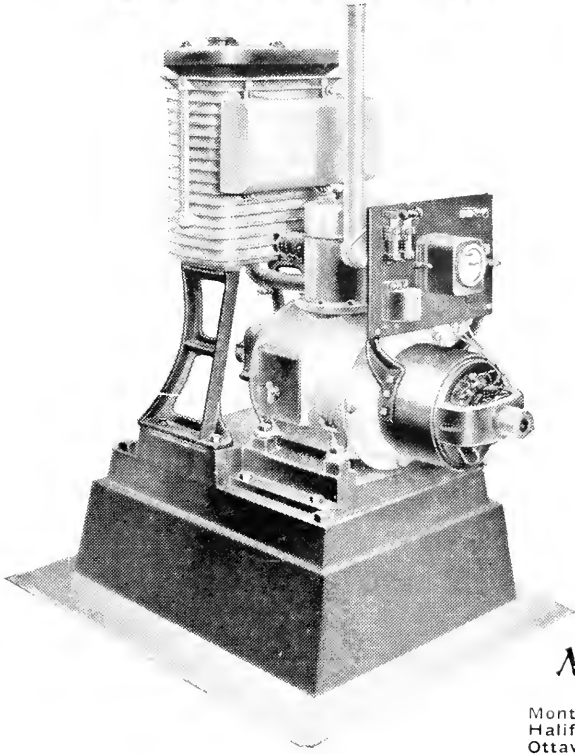

Electric Plants for Every Service  
350 to 5,000 watts.

Especially adapted to camps—saw-mills—  
construction work—stores—farms and all  
country houses.

This cut shows the Utility model  $\frac{3}{4}$  K.W.  
usually furnished with storage battery, but  
obtainable as a one-piece generating unit.

Its features include: Bosch Magneto—  
S.K.F. Ball Bearings—Electric Governor—  
and concealed Flywheel—it is self-cranking  
and stops itself when battery is charged.

*Northern Electric Company*  
LIMITED

Montreal  
Halifax  
Ottawa

Toronto  
London

Regina  
Calgary

Edmonton  
Vancouver  
Winnipeg

## Foresters' Equipment

---

MOSQUITO AND INSECT PROOF TENTS  
WATER AND MILDEW PROOF BAGS  
FROST PROOF SLEEPING BAGS  
ALL "WOODS" QUALITY

---

## Woods Manufacturing Co.

DEPT. D.

OTTAWA

**TREES, SHRUBS and SEEDS**

HARDY NORTHERN TREE STOCK

**EDYE-DE-HURST & SON, DENNYHURST**

DRYDEN, ONT.

Shippers to H.M. Government.

**Hill's Seedlings & Transplants**

ALSO Tree Seeds for Reforesting. Best for over half a century. Immense stock of leading hardy sorts at low prices. Write for price list and mention this magazine. Forest Planters Guide Free.

**The D. HILL NURSERY CO.** Evergreen Specialists  
Largest Growers in America.  
Box 503. DUNDEE, III., U.S.A.

**Try This Stump Puller at Our Risk**

The 5ml" Stump Puller will take out every tree and stump by the roots, clearing from one to three acres a day, doing the work of twenty men. We want you to send for our 3 year guarantee against breakage and our free trial proposition. Address  
**W. Smith Grubber Co.**  
11 Smith St.  
LaCrescent, Minn.



**GAGNON & MORISSETTE**

TIMBERLAND CRUISERS  
LUMBER CONTRACTORS  
FOREST INDUSTRIES

CHICOUTIMI, - - P.Q.

**LT.-COL. L. J. D. MARQUIS**

Forest Engineer and Mem. Can. Soc. of F.E.;  
Quebec Assoc. of F.E.; Former  
Mem. Que. F. Service

Timber Factors and Logging Costs  
Facts on Forest Growth and Future Products  
Forest Cruising and Mapping  
GIFFARD, - - - QUEBEC.

**Timber Lands Bought & Sold**  
Timber and Pulp Wood Estimates.

**R. R. BRADLEY**

CONSULTING FORESTER  
Globe-Atlantic Bldg. - ST. JOHN. N.B.

ASK



FOR



**Timber Estimating & Mapping**  
Management of Forest Properties.  
Supervision of Lumbering Operations.  
Forest Planting.

**COOLIDGE & CARLISLE**  
FOREST ENGINEERS  
BANGOR - - - MAINE.

**Timber Estimates**

**JAMES W. SEWALL**

Old Town, Maine.





## FAIRBANKS - MORSE FIRE FIGHTING PUMP

These outfits are replacing many  
men and doing work impossible  
by any other method.

*Send for Information.*

THE CANADIAN  
FAIRBANKS-MORSE  
CO., LIMITED

Offices in  
Every large  
Canadian City.

## FOREST FIRES IN NEW BRUNSWICK, SEASON 1919

Total number of fires in province this season, 342.

Total area burned over, 11,326 acres, or about 18 square miles.

Total damage done, \$154,155.00.

### CAUSES OF FIRES.

Railroads caused 240 fires, or 70 per cent of total, doing 3.5 per cent of damage.

Fishermen, campers, travellers and smokers caused 25 fires, or 7 per cent of total, doing 31.7 per cent of damage.

Settlers, neglecting clearing fires, caused 38 fires, or 11.5 per cent of total, doing 44.1 per cent of damage.

Industrial operations and careless use of fire, caused 13 fires, or 3.5 per cent of total, doing 7.1 per cent of damage.

Accidental, 4 fires, or 1 per cent of total, doing 7.1 per cent of damage.

Incendiary, 7 fires, or 2.5 per cent of total, doing 8.2 per cent of damage.

Unknown, 15 fires, or 4.5 per cent of total, doing 4.7 per cent of damage.

### PROSECUTIONS.

There were 36 prosecutions for violations of the Forest Fires Act of New Brunswick. These were principally against settlers for burning their slashings without a fire permit or neglecting to attend to clearing fires. Twenty-nine convictions were obtained, two cases were withdrawn, and five cases dismissed.



YOUR OUT DOORS FRIEND WILL  
APPRECIATE A 1920 SUBSCRIPTION  
TO THE FORESTRY JOURNAL AS A  
CHRISTMAS GIFT.

SEND IN HIS NAME WITH A DOLLAR  
BILL. 206 BOOTH BLDG., OTTAWA.





# QUEEN'S

## UNIVERSITY

KINGSTON,  
ONTARIO

**ARTS**

Part of the Arts course may be covered by  
correspondence.

|  |   |
|--|---|
| <b>MEDICINE</b><br><b>APPLIED SCIENCE</b>                            | <b>EDUCATION</b><br><b>APPLIED SCIENCE</b>    |
| Mining, Chemical, Civil,<br>Mechanical and Electrical<br>Engineering |   |
| <b>SUMMER SCHOOL</b><br>July and August.                             | <b>NAVIGATION SCHOOL</b><br>December to April |
| 26 <b>GEO. Y. CHOWN, Registrar.</b>                                  |   |

## UNIVERSITY OF NEW BRUNSWICK

FREDERICTON, N.B.

### DEPARTMENT OF FORESTRY

Established in 1908.

Best of facilities for definite instruction  
and supervision in Practical Forestry.

Surveying, cruising and construction  
work carried on in our own tract of 3600  
acres, with Forestry Camp in the centre.

Competent men from the School at  
present in demand to take up Forest Sur-  
vey work with the Provincial Crown Land  
Department.

For further information address:

### DEPARTMENT OF FORESTRY

University Calendar furnished on application.

C. C. JONES, *Chancellor.*

TABLE OF CONTENTS FOR NOVEMBER, 1919

|   | PAGE |
|---|------|
| Aircraft and Timberland. By Stuart Graham.....  | 435  |
| U. S. Experience with Aircraft in Forests.....  | 438  |
| Practical Studies in Forest Management .....  | 440  |
| What Tree Planting Does for Prairie Farmers. By Norman M. Ross.....                                       | 442  |
| Fighting "Bad Years" by Planting Trees on the Prairies. By Archibald Mitchell,<br>Coaldale, Alberta ..... | 444  |
| Forest Playground Built by Civic Government. By M. E. Bascom.....   | 451  |
| The State as Boss of Its Forest Properties.....   | 453  |
| The West Deserves Better Than This.....   | 457  |
| Quebec Logging Slash a Menace.....  | 460  |
| Learning How Pine Tree Crops Can be Ensured.....  | 461  |
| Prairie Provinces and Their Natural Assets.....   | 463  |

The Forestry Journal will be on your neighbor's desk every month—if you subscribe for him. One dollar a year.

206 Booth Building, Ottawa.

WANTED

**LIGHT RAILS**

State whether complete with splice or angle bars. Give size, quantity, location, condition and best cash price f. o. b. cars loading point.

Box No. B, Canadian Forestry Journal, Ottawa, Can.

**B. M McGRATH**

Colonial and Industrial Investments, Timber, Pulp Wood Areas and Waterpowers.

Newfoundland and Labrador Mines and Minerals.

Reports, Plans and Estimates Furnished

TRADE REVIEW BUILDING,  
ST. JOHN'S. NEWFOUNDLAND

**Victor Portable Stereopticon**

(Complete weight 11 lbs.)

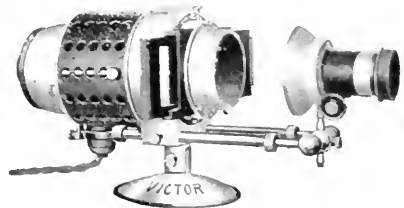

Can be used with any electric current, or supplied for use with Acetylene and Prestolite Tanks.

Write for Complete Catalog.

**SUPPLIES COMPANY  
OF CANADA  
LIMITED**

65 SPARKS STREET,  
OTTAWA, ONT.

# FOUR REASONS WHY SHREWD MEN ARE BUYING VICTORY BONDS 1919

## 1. *Security*

SHREWD men are buying Victory Bonds because Victory Bonds are backed by Canada's guarantee that she will repay the full amount stated on the face of the bond—the five-year bonds on November 1st, 1924; and the fifteen-year bonds on November 1st, 1923. And she not only binds herself to pay the money back, but she pledges all of her vast resources as security for her promise.

## 2. *Income*

SHREWD men are buying Victory Bonds because the interest return is unusually good considering the absolute security. You will be paid  $5\frac{1}{2}$  per cent per year on Victory Bonds— $2\frac{1}{2}$  per cent more than you can get in the Savings Banks. Unlike many other investments, you have absolutely no worry as to the prompt payment of the interest.

## 3. *Saleability*

SHREWD men are buying all the Victory Bonds they can pay for now and all they will be able to pay for during the next ten months under the instalment plan, because they know that if at any time they should need ready money they can sell them. There will always be a ready market for Victory Bonds.

## 4. *Advancement in Price*

SHREWD men are buying Victory Bonds because they consider them to have an excellent prospect of advancing in price.

ALL of Canada's previous issues of Victory Bonds have advanced. You can sell your Victory Bonds 1917 and 1918 even in this short time—one and two years—and get more than par for them. What will Victory Bonds be worth when the world finally gets back to a normal basis—when interest rates come down—when Canada will be able to borrow again at 4 per cent, or even less?

WAR conditions have created the opportunity for you to buy the very best Government securities on unusually attractive terms. Do not miss such a good investment opportunity, but buy to your limit.

# BUY VICTORY BONDS

Issued by Canada's Victory Loan Committee,  
in co-operation with the Minister of Finance  
of the Dominion of Canada.

IF YOU WANT A CHEW  
THAT WILL JUST SUIT

YOU ASK FOR

# **STAG**

## **CHEWING TOBACCO**

RICH AND SATISFYING.

IT IS ALSO KNOWN TO BE  
"EVER-LASTING-LY GOOD"



## Do You Require More Capital?

For ten years, Royal Securities Corporation has been associated with the development and financing of Canada's most successful pulp and paper enterprises. Among them are:

*Abitibi Power and Paper Company.*  
*Brompton Pulp and Paper Company.*  
*Mattagami Pulp and Paper Company.*  
*Price Bros. and Company.*  
*Riordon Pulp and Paper Company.*  
*Fraser Companies, Limited.*

Do you desire to pay off floating indebtedness; increase your plant capacity; or acquire additional properties? If so, why not let us suggest ways of financing your requirements? Our Engineering and Statistical Departments are at your disposal.

## Royal Securities Corporation L i m i t e d

164 St. James St.,  
MONTREAL

58 King St. West,  
TORONTO

# Canadian Forestry Journal

VOL. XV.

OTTAWA, CANADA, DECEMBER, 1919.

No. 12



A Midwinter Scene in a New Brunswick Lumber Camp

FACULTY OF FORESTRY

JUN 7 1920

UNIVERSITY OF TORONTO



## Field, Stream and Road

How strange the old-time pictures of sport would look today—baseball teams boasting at least half-a-dozen sets of whiskers—full-bearded cricketers—champions of the scull with their chins concealed.

Today the athlete knows the importance of the well-shaven chin. He is conscious that he is most keen when he is well-groomed—just as is the business man and the soldier.

For men who love outdoor life and sports, men of virile minds and active bodies, we have designed a Gillette Safety Razor with an extra stocky handle—the “Bulldog” Gillette, shown to the left.

Not that the Gillette needs a sturdy grasp. A light touch, with the angle stroke, removes the most stubborn beard with surprising comfort.

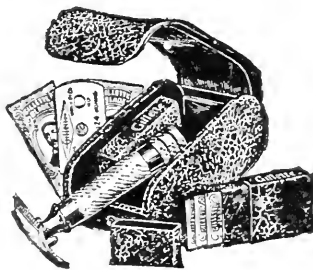

The “BULLDOG” Set includes oval Morocco Case with two blade boxes to match, and 12 double-edged blades.

But there is a certain appeal in the thicker handle of the “Bulldog”. Ask to see this special set and appreciate the point for yourself.

*The case, you will notice, is almost as compact as the famous Pocket Edition Gillettes, and the price is the same, \$5.00.*

*Sold by all dealers catering to men's needs.*



# Gillette

## Safety Razor



## OUR TWENTIETH BIRTHDAY WITH TEN THOUSAND MEMBERS

The Canadian Forestry Association will be twenty years old on January 15th, 1920. On March 7th, 1901, the membership was 244, and receipts \$192.45.

At December 1st, 1919, the membership totals over 10,000, and receipts for the current year are about \$18,000. The Association has made a membership growth in 1919 of about 2,700.

The preliminary steps towards the formation of the Canadian Forestry Association were taken by Mr. E. Stewart, then Chief Inspector of Forestry and Timber for the Dominion (now of Toronto), who sent out a circular letter on January 28th, 1900, to a number of men interested in the subject of forestry, asking them to meet at his office on the 15th of that month. At that meeting were present Sir Henri Joly de Lotbiniere; Saunders; Mr. William Little; Mr. Thos. Southworth, Director of Forestry for Ontario; Mr. E. Stewart; Prof. John Macoun, Assistant Director of the Geological Survey; Mr. Little was elected Chairman, and Mr. Stewart, Secretary.

## ONTARIO MUST FACE THESE FACTS NOW!

*By Robson Black, Secretary, Canadian Forestry Association.*

As a matter of good business management, New Brunswick, Quebec, and British Columbia have placed the public-owned forest lands under a united and technically-qualified management. The Dominion Government also charges its Forestry Branch with the administration of all timber sale business on the Dominion forest reserves, in the west.

In Ontario, aside from fire prevention, the forest possessions are still handled on substantially the plan of 1890. Revenues are collected and a nominal supervision maintained over timber operations on licensed Crown timber lands, as conducted by private companies. But in the true sense of government management of public-owned property, from the viewpoint of so regulating cutting methods as to leave cut-over areas in the best possible condition to produce another crop, Ontario has yet to make a beginning.

### FOR THE TAXPAYER'S NOTICE.

A very high percentage of the non-agricultural forest lands of Ontario are public-owned. The limit-holder is a lessee of cutting rights. His lease or license is renewed annually. He owns little or none of the land on which the timber grows. By retaining the land title, the province has always reserved the authority to impose such regulations as might be considered essential to the public interest. It is significant that the public management of forests in On-

tario, aside from fire protection and changes in dues—has not altered materially since the early days of exploitation.

Bearing in mind the state's admitted responsibility and legal authority in conserving the public forest wealth, some further facts demand consideration:

The greater part of the provincial land area is non-agricultural. Its productive ability is limited, therefore, to timber growing, mineral development and game production. Roughly, this classification applies to the vast region north of a line drawn from Ottawa to the southern shore of Georgian Bay, with substantial deletions here and there, as in the great claybelt area along the T. & N.O. and parts of the Canadian National Railways, parts of the Rainy River region and elsewhere. Northward and westward, to and beyond the height of land, Ontario possesses a natural timber-growing estate of incredibly large economic value.

### HOW MUCH FOREST?

The productive forest area of the province is estimated at between 80 and 90 million acres, containing about 150 billion feet of merchantable coniferous timber, made up mainly of spruce, white pine, jack pine, balsam and tamarack, in addition to large quantities of poplar, birch, maple and other hardwoods.

The most authentic estimates give the amount of spruce and balsam available for pulp and



Ontario's great name in the world's lumber trade is built upon white pine. But the annual production of white pine on Crown Lands has fallen 60 per cent in the last ten years.

paper manufacture as 200 million cords (100 billion feet, board measure); and white pine as 20 to 25 billion feet.

While such chains of figures may reasonably impress the layman with the tremendous richness of Ontario's forests, false conclusions

should not be drawn. The forest resource is far from "inexhaustible." This year two new paper mills of enormous capacity have been put under way in Ontario's timber zone, and others are projected. The future will see a remarkable development of paper manufacture within

## IS ONTARIO PREPARED TO ACT?

The Canadian Forestry Association has laid before Hon. E. C. Drury, Prime Minister of Ontario, a plan for the reorganization of the provincial scheme of forest management. It involves two major changes:

The transfer of the entire woods administration to the control of the Provincial Forester and a staff of experienced technical men. This would concentrate the management of the forest resources in the hands of a single branch, technically qualified for such important duties;

It would provide for carrying on a public duty for which no provision to-day exists, viz: the supervising of timber cutting and the ensuring of permanently productive forests

Secondly, the appointment of a Forest Advisory Board, similar to the New Brunswick Board, consisting of three Government members and two representatives of the wood-using industries, to have full authority over the selection and appointment of all fire-rangers, timber-scalers, and other employees, thus ridding the staff of patronage interference and securing discipline and efficiency.

There is not at the present time one technical forester in any administrative relation to the 15,000,000 acres of licensed timber berths of Ontario.

The suggested reforms in Ontario forest administration are not designed to upset ordinary commercial methods of logging, any more than they do in Quebec, New Brunswick and British Columbia, where all timber operations are under control of the Provincial Forest Services.

The lumber and paper industries in Ontario are of vast economic magnitude and the utilization of spruce and balsam supplies for pulp and paper is only on the edge of a wonderful development. It behoves the Province, therefore, to insure the permanence of the raw materials of the living forest by better fire protection and better methods of logging. Permanence in the forest itself is the aim of good Forestry. The migratory forest, the transient sawmill, the effervescent lumber town are incidents of a primitive civilization and the absence of modern scientific method in handling timber areas.

Ontario is master of its conservation policies. The main areas of the more valuable timber lands are owned by the Provincial Government.

the provincial borders, owing largely to the great demand created by forest depletion in the eastern United States. The latter, once richly forested, are now so reduced by forest fires and industrial exploitation that there is not a ten years' supply of spruce for the existing mills and no possibility of new pulp enterprises getting under way. It is estimated that the United States clears off 20,000 acres of timber a day to meet its requirements and much of this is not being left in a condition to pro-

duce another crop in any reasonable length of time. Ontario stands to gain by this exhaustion of basic supplies south of the border, but the gain can be but temporary unless the management of Ontario's forests is guided by a constructive modern policy, looking toward the systematic growing of successive timber crops on non-agricultural lands.

### THE MARKET SHOWS IT.

Again, the presence of 20 to 25 billion feet of white pine may appear a large supply. Yet

the fact remains that the scarcity of accessible white pine is so marked in Ontario that prices have now risen to \$80 to \$100 for a thousand feet, board measure, of pine strips, attributable not alone to production cost increases, but to scarcity of raw materials, not only in Ontario but elsewhere. Many of the large pine manufacturers in Ontario have placed a limit of three to five years on their pine log supply. Nearly 100 million feet less pine timber was cut from Crown lands in the fiscal year of 1917 than in the year previous. Labor shortage was undoubtedly a factor in this, but a long series of years presents a sharply decreasing return for the amount of pine timber cut. Ontario Government statistics show that the cut of pine from Crown lands was around 790 million feet in 1907, 630 million in 1908, 383 million in 1914, 308 million in 1908, 208 million in 1917, and 223 million in 1918. The year 1916 was the last in which white pine square timber figured in the official returns, when it was but slightly in excess of one million feet, as against over 12½ million feet in 1907. In the early days, square pine timber comprised a high percentage of the timber cut of the province, and formed the foundation for Ontario's reputation abroad as a great timber-producing region. These figures show a steady but rapid decline in the cut of pine, which can only be accounted for on the whole, by correspondingly diminishing supplies. This reduction in the cut of pine is, of course, offset by greatly increased cuts of spruce, balsam and jack pine. The change in the character of the operations is significant of the change which is taking place in the character of the forests, the more valuable coniferous species giving way to the less valuable, and these in turn, in many sections, to the hardwoods. A reduction of nearly two-thirds in the cut of pine between 1908 and 1918 is so significant of the deterioration in the quality of Ontario's forests that it challenges the most serious consideration. As in New Brunswick, where pine has fallen from absolute monopoly of the annual cut to a poor sixth place in the present-day volume, so in Ontario the elimination of the pine forests and the pine supply that plays a mighty role in provincial commerce may be accomplished within a few years.

#### WHERE ONTARIO STANDS.

As with pine, so with spruce, and other species, the supply can be maintained only by applying the public authority to methods of private exploitation on Crown timber lands. In Ontario at present such public authority is

practically valueless for the reason that the entire area of berths, roughly 15 million acres of our finest timber, is subject to only a few regulations which look primarily to the collection of revenue, rather than to the perpetuation of the forest as a source of supply. In only a comparatively limited number of cases is there any restriction as to the size of trees to be cut, and only recently and in a very small number of cases is there any provision for the enforced disposal of logging slash as a fire-preventive measure. Ontario's choicest forest sections are handled by the Department of Lands and Forests purely as a bit of revenue collecting. (The 1917 collections from timber dues and fire tax amounted to over \$1,695,000.) In the highly technical department of forest management, Ontario has not yet utilized one technical forest engineer and has attempted no extensive investigations of its forest lands with a view to their productive maintenance and no revision of ancient regulations along the lines of constructive forestry. The department maintains a forester primarily for fire protection work and tree planting, rigidly excluding specialized forestry knowledge, or any forest conservation plan from its handling of the timber berths. This plainly ignores the practice of nearly every forest-owning government in the world. It is opposed to the successful examples of New Brunswick, British Columbia and Quebec, where all branches of public management of the forest resources are under the single authority of the Provincial Forester and a staff of technically-trained inspectors.

The efficient handling of any state-owned property is direct consequence of a well-tested system and a well-skilled staff. The Ontario system of "handling" the fifteen million acres of timber berths under lease at the present time is as follows:

#### WHAT A "LICENSE" MEANS.

The berths are under annual lease. The lessee pays direct to the Department of Lands and Forests annual ground rent of \$5 per square mile, a fire protection tax of \$6.40 a square mile; fixed stumpage dues of so much per thousand feet, per cord, or other unit of measurement, and a bonus per square mile or per unit of measurement, the amount of which is determined by competitive bidding after the limit is advertised for sale. For example, while the fixed stumpage dues on white pine may be only \$2 per thousand feet board measure, the bonus offered by the purchaser of the limit has, in some cases, brought the total stumpage pay-

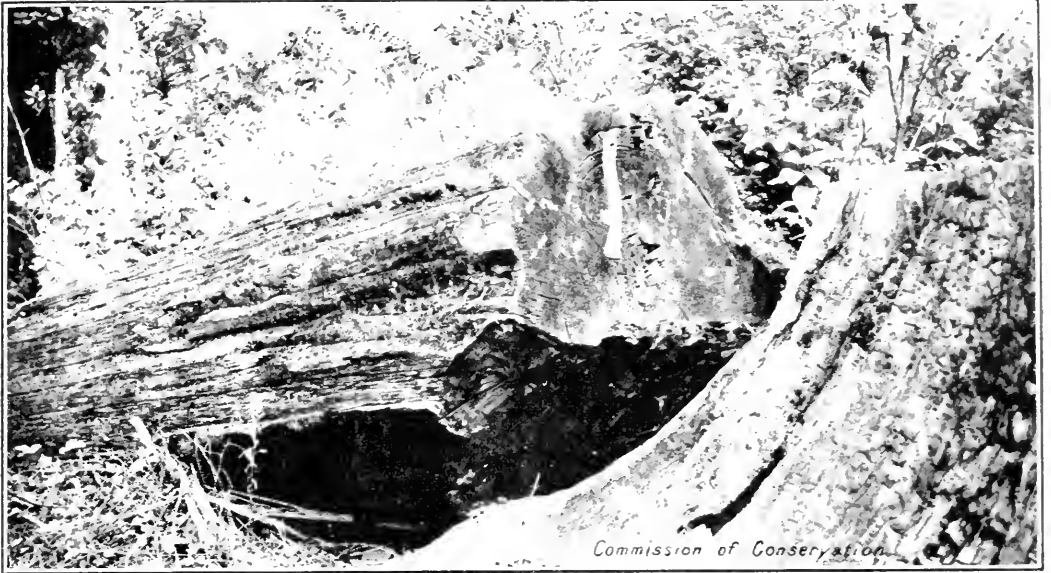

A white pine log cut in Ontario 23 years ago and left in the woods as "defective" according to the standards of that time.



The log harvest that draws \$10,000,000 a year for Ontario's lumber production. Note size of logs today compared with the top picture.



An abandoned gold mine in Central Ontario. View shows a former pinery that once grew 60 merchantable pine trees to the average acre. To-day a vast area in this section is a No Man's Land.



Nature made a commercial forest here. Man made a barrens.  
Photo taken on the Trent Valley watershed, Ontario.

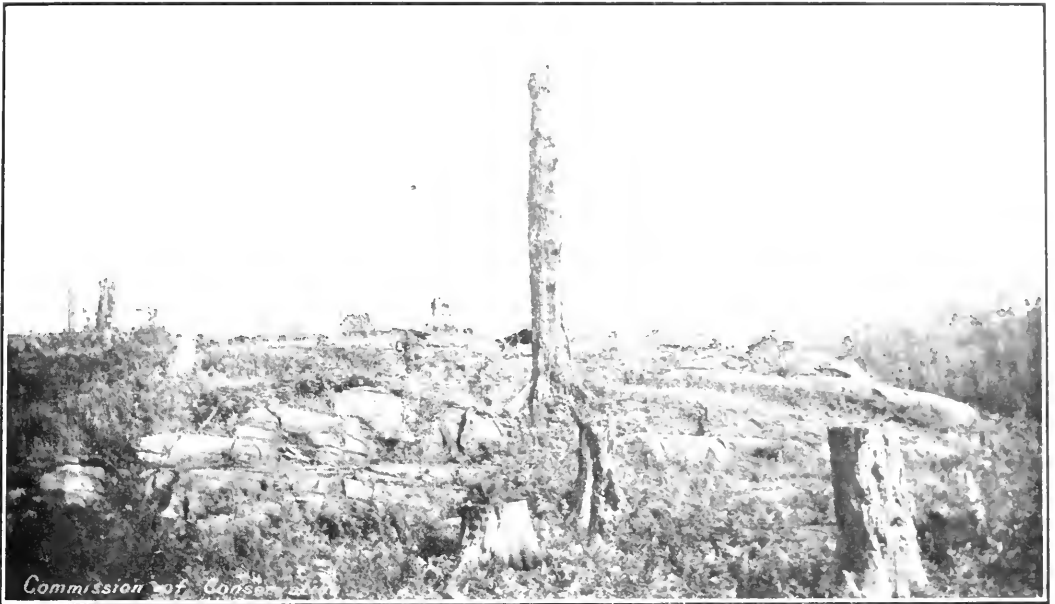

Once a great pinery in Middle Ontario. To-day, the effects of forest fires have turned the area into a useless waste.

ment up to as high as \$24 per thousand feet, for particularly desirable and accessible white pine. Fixed stumpage dues for spruce saw logs may be \$2 per M.; for spruce pulpwood, 20 cents to 40 cents per cord, and for balsam pulpwood, 20 cents per cord, all of which may be materially increased on account of the bonus tendered by the successful purchaser. The dues are collected by the Crown Timber Agent in each of the divisions. He in turn works through timber scalers.

To renovate the existing system, managing a valuable part of the public estate by introducing proved business methods in the collection of stumpage dues, suggests no interference with the essentials of commercial lumbering. It undertakes only a more business-like handling of the situation, coupled with the development and adequate enforcement of intelligent and practical regulations calculated to leave cut-over areas in a condition to produce a new crop of timber.

*(To be continued.)*

#### WIRELESS PHONES IN MANITOBA.

Winnipeg, Man. Churchill, Norway House, Grand Rapids, and all isolated settlements will be brought into touch with civilization through the winter, if the recommendations of Com-

missioner R. C. Wallace for the wireless telephone system for Northern Manitoba are adopted by the Manitoba Government.

Hon. Edward Brown, Attorney-General, said it would mean that the whole of the "added territory" will be connected up. The system will cover a territory of more than 175,000 square miles and will prove of immense value.

#### MR. KUHRING PROMOTED.

Mr. Gustave F. Kuhring, B.Sc.F., from the University of New Brunswick, has resigned his position with the New Brunswick Forestry Service to accept a position with the Riordon Pulp and Paper Company, at Montreal, under their Forester, Mr. ABYberg. Mr. Kuhring commenced his forestry work with the Laurentide Company in 1913. He has over four years' service overseas to his credit, being wounded three times and honorably mentioned in despatches, and was engaged with the N.B. Forest Service on forest survey work since returning. Mr. Kuhring expects to leave Montreal early in January for an extensive dog-train trip into the North.

Mr. Kuhring is one of the several New Brunswick Foresters who have recently accepted responsible assignments with private lumber and pulp companies.

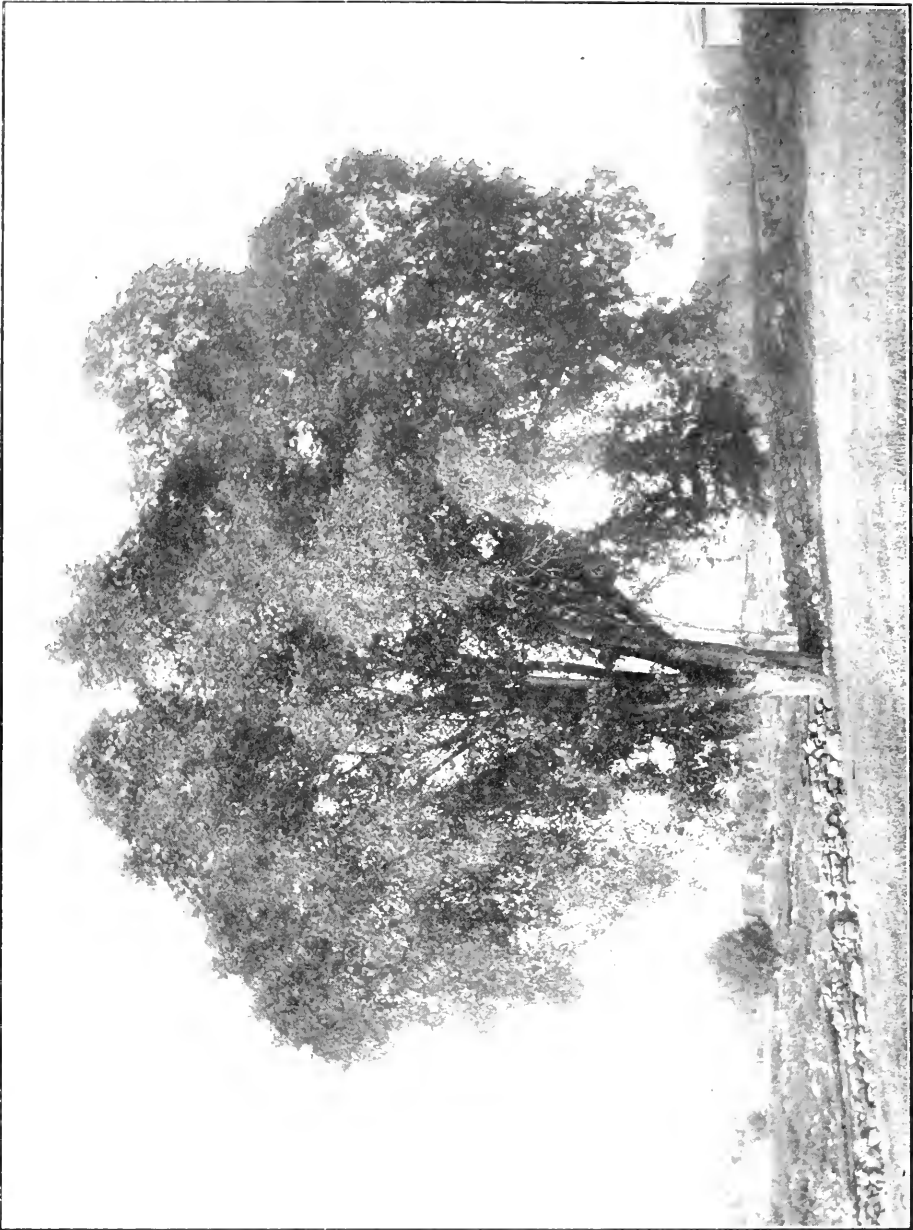

Several readers of the Forestry Journal have been kind enough to send in photographs of the "American Elm." This shows a beautiful specimen from the collection of the Central Experimental Farm, Ottawa.



# MAPLE SUGAR PAYS QUEBEC YEARLY FORTUNE

By C. Vaillancourt, Quebec.

## Thirty Million Pounds, Valued at \$7,500,000—Special Schools to Teach the Art.

The maple sugar industry has increased three-fold in Quebec Province during the last three years, mainly owing to the scarcity of beet and cane sugar, and the continual rise in the price of the product.

But one factor which has stimulated perhaps more than anything else the development of our sugar industry, is the sugar-making school. A number of sugar schools were established at various places by the Department of Agriculture and many demonstrations in sugar-making were given in all parts of the province by special instructors sent here and there, at the expense of the department.

There are three sugar schools in the province: One at La Minerve, Labelle county, another at Beauceville, Beauce county, and the third at Ste. Louise, L'Islet county.

Modern methods of sugar and syrup making are taught in these schools. Young men who desire to learn sugar-making or to perfect themselves in this industry have only to apply to the Minister of Agriculture, and on receipt of a letter of authorization, they may spend eight, ten or fifteen days at one or other of these three schools and get very practical lessons on the modern methods of making maple products.

The department pays the board of these students during their attendance at the sugar school.

Of course, in all these sugar schools modern evaporators and implements are used. Everything is kept in the greatest condition of cleanliness from the tank in which the sap is gathered to the can in which the syrup is put. The pans are washed every morning. Cleanliness is, of course, one of the most important essentials in the making of choice products.

Five instructors in sugar-making gave demonstrations throughout the province on the use of modern methods of sugar-making. The total number of demonstrations given was ninety-four in eighteen counties of the province.

At a certain date, which is arranged beforehand, the sugar-makers are called by the instructors in one of the sugar groves of the province. The instructor makes sugar himself, by using material which he brings with him. Then the makers may ask all the information they desire to have. Such demonstrations have been very successful wherever they have been held. It is assuredly the most practical way to teach the good methods of sugar-making.

Such demonstrations have been going on during the last four years and the results of this practical method of teaching are already seen, as this year the purchasers say that about 75 per cent of the sugar manufactured was first quality.

Of course, there remains improvements to be made, but we are happy to record the splendid results of the work already done and which augur well for the future.

The total crop of sugar in the province was not quite as large as that of 1918. In some districts, there was more sap than last year; in others the quantity collected was hardly one-quarter of that of the previous season. In the Eastern Townships and in the Quebec district, the season was very good and the sap of better quality than last year. On the other hand, in the counties of Portneuf, Champlain and the Three Rivers district the crop was very much below that of other years.

The exact figures are not known as yet, but the quantity of maple sugar manufactures in our province this year probably amounts to 30,000,000 pounds.

If these 30,000,000 pounds are valued at 25 cents a pound, which is far from an exaggeration, this makes a total of \$7,500,000. The crop of 1911 had been about 10,000,000 pounds. As may be seen by these figures, the industry has developed on a very large scale during the last few years.



### THE PRINCE JOINS US!

The Prince of Wales is one of the latest recruits in the growing membership of the Canadian Forestry Association. A letter received by the Secretary of the Forestry Association from Sir Godfrey Thomas expresses the interest of the Prince in accepting Honorary Membership in the Association. "I should be glad," writes the Private Secretary to His Royal Highness, "if you would inform the Directors that His Royal Highness much appreciates this invitation which he is pleased to accept."

### PLANTING UP A WOODLAND.

Lieut.-Col. J. W. Harkom, Melbourne, Que., a Director of the Canadian Forestry Association, and one of the most devoted supporters of the forest conservation cause, has never contented himself with anything short of active participation in forestry. This year Colonel Harkom undertook to improve his woodland property by planting two thousand white pine, European larch and Norway spruce, and next year will plant at least five thousand seedlings. These have been planted in the openings from which mature timber has been cut. Colonel Harkom has found that about 85 per cent of the planted stock survives.

# ATTENTION PLEASE

---

---

## This Affects Every Member of the Canadian Forestry Association

Every recipient of this issue of THE CANADIAN FORESTRY JOURNAL is a member of the Canadian Forestry Association.

THE JOURNAL is the Association's line of communication between the executive staff and the fast-growing membership. But after all, THE JOURNAL is only incidental to your personal effort in the national cause of forest conservation. To you the publication may be good company, but the real spear head of constructive propaganda is the Association itself, its vigorous groups of members in a thousand towns, its lecturers, its successful campaigns to secure better laws and administration, its Railway Forestry Car; its motion pictures; its publicity bureau.

The Journal has its own worthy place, but the power that performs actual aggressive educational service is the organized membership working through a small executive staff at Ottawa.

We cannot emphasize too strongly that the Association is not a Government Department or an appendage to any commercial body. It represents Community Interest in forest conservation; it represents you as a Citizen.

We take for granted, you'll stand by the Association in 1920. It ought to be the greatest year in our history. Remarkably few men drop membership from year to year.

### WHERE YOUR ANNUAL FEE GOES.

The Forestry Journal used to be a 16-page pamphlet. In those days the membership fee of one dollar paid the printer and left a fine surplus for the general work.

To-day, the printer takes every penny of your dollar fee for the paper and printing cost of our present publication. Advertising revenues are negligible. We do nothing more with the total of membership fees than to pay publication costs. And 1920 paper and printing prices will be even higher.

## AND SO WE ASK—

in order to pay the printing cost of your personal copy of the Forestry Journal, and put some muscular power into your "Membership" in the Forestry Association, that you accept the following new basis of annual membership:

|  |               |
|--|---------------|
| 1920 Membership fee in the Canadian Forestry Association ..... | \$1.00        |
| 1920 Subscription to the Canadian Forestry Journal .....       | 1.00          |
| <b>Total for Membership and Subscription</b>                   | <b>\$2.00</b> |

That is, we separate the Journal subscription from the membership, both of which were formerly included in the fee of one dollar. They now become one dollar each.

By the new arrangement, **any one paying one dollar will receive the Forestry Journal, as formerly.**

By paying two dollars, you get a year's subscription to the Journal, and in addition you make your personal alliance with the Association a real working force. That second dollar is the vital one in our educational campaigns.

(No one who has paid his fees for 1920 or who took out a 1920 membership on the basis of a one-dollar inclusive fee will be affected by the foregoing.)

## THREE REQUESTS—THREE DUTIES

1. Do not quit the Association. Its battles are only half-fought.
2. Send in a dollar bill for your Forestry Journal.
3. And at the same time add a second dollar to pay for your Membership.

Yours faithfully,

CANADIAN FORESTRY ASSOCIATION

**10,000 members—15,000 soon.**

## PROGRAMME FOR PRIVATE FORESTRY

*By H. S. Graves, Chief Forester of the United States.*

In seeking a solution for the forestry problem on private lands, it should be recognized that its very character is such as to require public participation, assistance and direction. There are certain things that the public should do, and in a liberal spirit, to make forestry by private timberland owners possible and effective. At the same time the public should insist by adequate legislation that the destructive processes be stopped, and that methods be adopted which will leave the forests in a productive condition. To secure these ends there is necessary a broad programme that is practical and equitable, based on consideration of existing economic conditions. Its formation calls for the most careful constructive thought, with no point of view neglected.

Some principles may, however, be briefly indicated. A programme of forestry should include, first of all, compulsory fire protection;

and this should apply to second-growth and cut-over lands as well as to old timber. State laws should be unequivocal, with adequate penalties in their requirements upon timberland owners for protective measures, including the prevention of dangerous accumulations of slashings. Fire protection should be organized and under state supervision. The states should provide an effective organization to enforce the fire laws and to administer the organized protective work. Liberal funds should be made available for patrol, improvements, supervision, and inspection. In most of the states the laws are not drastic enough; there is not sufficient direct responsibility on the owner, and there are not provided adequate means to execute the laws and administer the protective work. The damage by forest fires can be stopped. Its continuance is due to a combined failure on the part of the public and the owners.



Fig. 1. Large pile of cut logs, showing the well-depleted condition of the timber in the Columbia range, about one-half mile from the town of Bonanza, British Columbia.



Fig. 2. Large pile of cut logs, showing the well-depleted condition of the timber in the Columbia range, about one-half mile from the town of Bonanza, British Columbia.

## TORONTO GETS A TREE NURSERY.

Parks Commissioner Chambers of Toronto has received authority from the Committee on Parks to negotiate for the purchase of a nursery farm of some thirty acres in the vicinity of the city for the propagation of seedling trees and shrubs to be used in local parks.

Land in the counties of Halton and Peel, the commissioner reported, was most suitable for the purpose, and could be purchased at from \$650 to \$1,300 per acre. He estimated that the establishment of a nursery farm would involve an expenditure of approximately \$35,000 and would yield the city a profit by the end of four years.

## STEEL CARS SHORT-LIVED.

The Railway Review editorially says:

"When the steel car was introduced the idea became current that the life of a car so constructed would prove to be a pretty definite quantity, much exceeding the life of wooden equipment. For years it was professed that the life of the steel car was unknown from the fact that no such cars had actually passed out of existence through legitimate wear and tear and, naturally, it was something of a shock to have the committee above referred to come in with a report that the life of steel cars was but 13.1 years and that their scrap value was but 12 per cent of the original cost."

The committee in question made its report at an annual convention last June as a result of a canvass which showed that 953 steel cars had been scrapped after the average service stated. The Railway Review lays the blame upon the fact that iron is not as pure as it used to be.

Wood is, however, the same old reliable material as of yore and the above figures appear to indicate that there apparently is still some hope for the continued renaissance of the wooden car, following its resurrection during the war period as an emergency measure.

—*American Lumberman.*

## ASH WOOD IN ITALIAN AVIATION.

In making the frames and wings of aeroplanes and airships in Italy, preference is given to ash wood because its fibres are fine, compact, strong and with few knots. Ash grows well in the south and centre of Italy, in loose, slightly moist, or even dry soils. Its trunk is straight and exceeds 65 feet in height.

## THE POINT OF VIEW.

*By Douglas Malloch, the Lumberman Poet.*

I guess it is all in the point of view—

That a joy's a joy or a pain a pain,

That a thing is easy or hard to do,

That the heart will sing or the heart complain,  
According to how it appeals to you.

There's a little house by the P. R. R.—

I bet you have passed it lots of times

As you sat alone in your parlor car—

Perhaps you noticed the ivy climbs  
To westward side where the roses are.

Yes, I know you have. That's an ivy vine

That you seldom see in a land so young,

I planted it back in '59,

And for sixty years like a friend it's clung  
To this little old wooden house of mine.

And the roses, too, you must have seen—

Two perfect ones by the open door

As pink as the cheeks of a fairy queen.

On the southward side there are seven more,  
White, yellow, and all the shades between.

And here I water and tend and prune

And watch and gather and fool along

And know about all there is of tune

And hear about all there is in song—

And that's a heap in the month of June.

I figure you see me riding by,

You busy man with your big affairs,

And think what a life to live, to die

Of all of the wide world unawares.

But it's all in the point of view, say I.

You may pity me. It's a funny thing,

But I never pity myself at all:

I stir the ground when the robins sing,

And then it's summer, and then it's fall,

Along comes winter—and then it's spring.

I guess it's all in the way you see,

I guess it's all in the view you take;

And you needn't sorrow or sob for me

When you think of the millions that others make,

For I'm not as poor as I seem to be.

# FORESTRY'S BIRTHDAY 1000 YEARS AGO

*Prof. Filibert Roth.*

According to Fernow's History of Forestry, and others, France appears to have taken a lead in real forestry when Charlemagne, the first great king of the Franks, more than a thousand years ago began the protection of forests and the regulation of their uses. As early as 1291 there were regular laws applying at least to parts of the forests and regular official foresters. In 1402 a general law was promulgated by the king. In 1669, after eight years of labor by a commission of twenty-one experienced and informed men, the Minister Colbert, of Louis XIV, promulgated the famous forest law, "l'Ordonances des Eaux et Forests," which at that time was the most complete forest law in existence. This law provided a very full machine for its enforcement; every important cut of timber had to be marked out by state officials; it prescribed the minimum age at which to cut timber, set forth officially the seed tree method, "methode a tire et aire," etc.

In practice this law became irksome tyranny; it made grafters and bad men instead of interested foresters; it led good people to use bribery and other low means to escape its action. It hindered forestry in its development.

The motive was excellent, the organization, on paper, was perfect, the law did much good as well as harm, and its failure lay in ignoring justice and freedom of action, and in disregarding the initiative of the owners of the land and the peculiarities of the business. The commission failed to see that the details of handling a forest can no more be prescribed by law than the running of an ordinary mixed farm. In 1791 all was thrown overboard by the revolutionary government. But in 1803 Napoleon re-established the old regime, much modified, to be sure, but included a definite clause which forbade all forest clearing without permit.

In 1827, after things in France came to rest, a new law was established. This law of 1827, revised in 1859, practically re-established the law of 1669; left out the unwise prescriptions as to silviculture, but kept the order of 1803, so that to this day the old law of 1669 holds and the forests of cities, towns, and all public bodies are under the state authorities; private forest may not be cleared without permit and

may not be devastated, but any area cut-over must be restocked within three years.

Germany has gone through about the same experiences, but since it never was a single state, but remained in its more or less feudal form of a loose union of many states in which every lord and prince, every bishop, and every city or town had its own authority, there never was a single uniform forest law for Germany. In most states, and with most large forest owners, city or prince, the first regulations or orders forbade clearing the forest and forest devastation. Later on these were amplified by each owner for his particular locality. In some states the French revolution brought radical changes, as in Prussia where all private owners of forests were allowed by the law of 1811 full freedom to cut and clear and handle their property as they saw fit, while in other states, like Bavaria and Wurttemberg, the older laws, dating back to about 1500, were retained and are practically those in force today.

## BRITAIN MAY BUILD WOODEN HOUSES

A special cable despatch from the London, England, correspondent of the *Montreal Gazette*, states that the probabilities are that Great Britain will adopt wooden houses as a solution of the acute housing problem in that country. The cable further states that F. C. Wade, agent general for British Columbia, has offered to have 500 wooden houses delivered in Great Britain and ready for occupation by Christmas. While there is a certain amount of opposition in certain quarters to wooden houses, it is significant that the by-laws prohibiting the erection of wooden structures are being amended. If wooden houses are finally adopted by Great Britain it will mean an immense boom for North American lumber.

— *Southern Lumberman.*

## AN ODD STUDY OF TREE STUMPS

### Grafted Roots Form Underground Pipe Lines to Keep Alive the Defoliated Trunk.

By C. C. Pemberton, Victoria, B.C.

The overgrowth on stumps of Douglas and Grand Fir is a very noticeable feature in the woods of the vicinity of Victoria, British Columbia, and first attracted my attention many years ago.

Believing that foliage was necessary to maintain life in a tree and always finding these stumps more or less in the neighborhood of other standing foliage trees of the same species, I concluded that a union of roots between the stumps and tree was the cause.

When, however, a few years ago, I began to assemble photographic studies of characteristics of our native trees for the Natural History Society of British Columbia, one of the first things I sought to learn through correspondence with authorities on the subject was the ascertained, scientific explanation of the matter. Many conjectures and opinions were expressed, but not a single account of actual investigations was given.

Among foresters, lumbermen, farmers, etc., to whom I first spoke and who had observed these stumps, the prevailing opinion seemed to be that the growth of new wood was caused by reserve material in stump, and the idea of its being due to root-union was doubted.

Many botanists to whom I wrote and sent photographs, held that the callus formation was due to reserve material in the stump, while others again expressed the opinion that such vigorous growth was impossible without foliage or root connection with a tree possessing foliage.

#### A EUROPEAN VIEW.

The first person from whom I obtained authentic information was Professor Somerville, of Cambridge University, to whom Mr. James R. Anderson, of Victoria, had sent some of the photographs of these stumps.

In a letter to Mr. Anderson, April 23rd, 1919, he says (referring to these stumps):

"This is the condition of things we often find in the larch in Europe, which, of course, is a deciduous tree, as contrasted with the evergreen character of the Douglas fir. So far as I have observed, the larch is the only conifer indigenous to Europe, which fre-

quently shows this condition of things, and it is usually attributed to the inarching of roots of adjoining trees, the stump of one that has been felled, procuring a good deal of nourishment from the roots of one or more adjoining trees that have been left growing.

"I do not know that this subject has been exhaustively investigated, but it would be interesting to make an examination of a large number of larch trees which have stood well removed from other individuals of the same species and which have been felled some years before. In such cases, one would not expect callusing of the stools for, if the theory is well founded, it is only where other trees of the same species are left to grow in the immediate neighborhood of one or more that has been felled, that one would expect to find this phenomenon.

"That the roots of trees in a wood grow together to a large extent is an undoubted fact, and the photographs that you have submitted show this very conclusively. Of course, one can have a certain amount of growth taking place in a stem which has been severed from the stump, provided the stem is laid in a cool, moist place, in which event the cambium becomes active in the spring, and ten per cent or more of an annual wood-ring can be formed in the ensuing season. I have found this notably in the larch, but I doubt not it occurs in other species."

#### MR. PEMBERTON'S FINDINGS.

Whilst, as already related, I sought information through correspondence with authorities, I also took every opportunity of investigating the characteristic of overgrowth of stumps as well as that of the frequency and cause of root-union.

I examined a multitude of overgrown Douglas and Grand fir stumps in the vicinity of Victoria, not only those in which root systems were already exposed to view, but by uncovering many others with root systems deeply buried in the soil.



I searched also for intermingling of roots and evidences of frequency of root-graft in neighboring areas where stump pulling and land clearing operations were taking place, and carefully inspected many spots in the local forests in which intermingling of roots was to be seen. While overseas I had especial opportunities of noticing whether in intermingling of roots, in-arching and root grafting occurred among conifers, since in England and France, the stumps were usually removed after the felling of the trees. The results of these observations and investigations seem to prove:

Firstly—that in some species root-unions, direct and indirect, with a tree possessing foliage, cause healing and overgrowth to occur on

the stump of the tree felled, but in other species do not do so. I have never been able to learn of or to discover a healed stump quite isolated, which thorough investigation did not prove to have direct or indirect root-union with a standing tree retaining its crown.

Secondly—that roots of the same tree or of a similar species of tree, can intermingle without intergrafting. Natural grafting, however, readily occurs through or by friction and pressure when roots of a single tree or of two separate trees of the same species are brought into contact by their increase in size, by elongation in growth, or where the tap-root of one tree in descending meets the secondary root of another tree spreading horizontally.



Here we see a stump of a California Sequoia tree wholly covered over with a cap of lichen wood.



Nature's way of healing over stumps of Douglas fir. As Mr. Pemberton's article explains, the growth is provided for by a graft of the roots of the stump with roots of a tree bearing foliage.

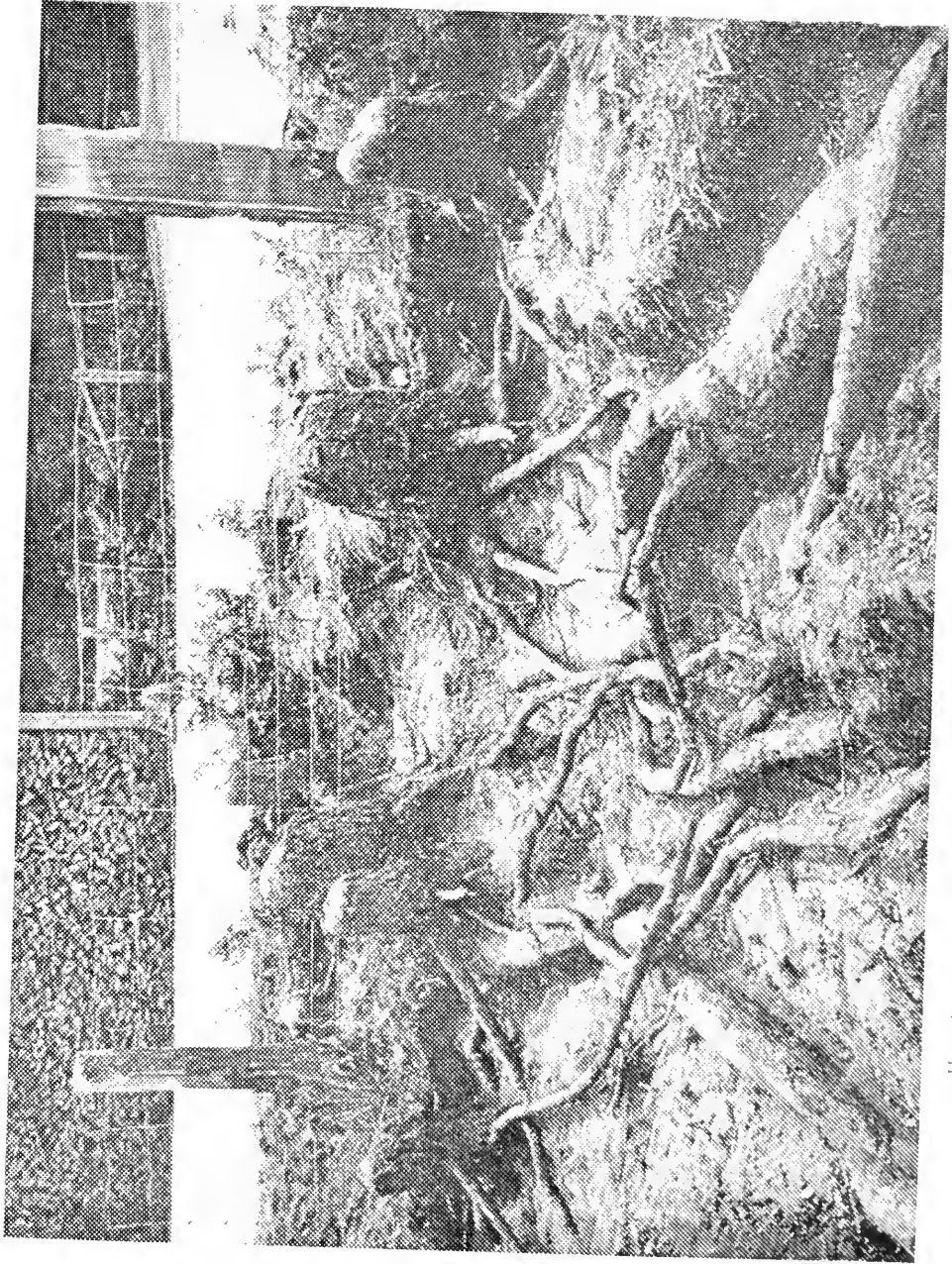

How trees are sometimes united by root grafts so that "dead stumps" continue to draw life from a live neighbor. This picture taken by Mr. Pemberton illustrates this natural curiosity very well. The stumps of Bonedars fir have continued to grow a bark covering over the exposed wood. It will be seen how their roots reach into the foreground, grafting with those of trees fifty feet away.

## MINING COMPANIES PLANT FOR PROPS

Harrisburg, Penna. Hon. Robert S. Conklin, Commissioner of Forestry, stated to-day that the most promising development of the past year in the field of reforestation is the interest mining companies are taking in forest tree planting. Fourteen different companies already have committed themselves to the practice. During the past four years mining companies have planted over 450 thousand trees, of which number 250 thousand were set out during 1919.

Coal companies are beginning to see the value of reforestation. They are experiencing great

difficulty in procuring suitable mine timber at a reasonable cost, and they realize that it is now possible to grow timber of usable size on their own holdings, at present almost entirely unproductive, long before the supply of their mines will be exhausted.

Commissioner Conklin predicts that mining companies will plant at least 500 thousand trees during 1920, and announces that the Department of Forestry is co-operating with them by supplying the planting stock, and giving technical advice free of charge.

## BRITISH ISLES READY FOR PLANTING SCHEME

London, England.—When the last of three-decker men-of-war ran off the slips British forestry died.

The oak forests, planted after Trafalgar for the express purpose of building Britain's wooden ways, stood untouched at the beginning of the war. When the overseas supplies of timber were cut off, the country had cause to bless the men who unconsciously planted for an emergency greater than any which they could have contemplated.

Serious effort now being made toward afforesting Great Britain is the result of the hard lesson learned during the war, and is but one of many hopeful signs of the intelligent reconstruction visible here. Britain can never be self-supporting in the matter of timber, and, whatever success may attend the present endeavor, it is not likely she will import a single log the less for a generation.

But, thanks largely to the splendid work of the Canadian Forestry Corps, her woods are a picture of desolation, and, even before that most successful attack, the area under timber was only 4 per cent of the whole.

The proposal is to spend three and a half millions sterling in planting a quarter of a million acres during the next ten years, under centralized authority, possessing wide powers and capable of laying down a well-defined, far-reaching policy.

Britain has never had a real forestry department, and one of its advantages will be that edu-

cation in forestry will be greatly stimulated, and a worthy career opened to experts.

The House of Lords, which has approved the scheme, knows more about such subjects than the commons, and it is hoped no serious opposition will be encountered in the Lower House.

### PULP SCARCE—INQUIRY STARTS.

Washington, D.C.—Scarcity of wood pulp in the United States is becoming so serious that Congress will make a survey of the industry, Senator Gronna, chairman of the Forestry Committee, announced. A superficial survey of the paper industry by the committee shows that many daily papers, especially in the smaller cities, are unable to secure necessary print paper, and that the paper which is available has increased in price to such an extent it is difficult for small papers to continue at a profit.

### BLACK WALNUT PLANTING

One hundred and fifty bushels of black walnuts were planted this fall in the Mont Alto nursery, Penna. The seed was good in quality and should produce 100,000 seedlings for planting next year. Most of the trees will be distributed to private planters throughout the State, who are anxious to start groves of this valuable tree, the wood of which was in such demand during the war.

# THE VALUE OF PRAIRIE WINDBREAKS

By M. J. Stevenson, Morris, Man.



One thing that is very conspicuous by its absence on a great many of our prairie farms, is a good wind-break or shelter-belt.

There can be no question about the benefits to be derived from such planting—both in winter and summer.

If there is a more desolate picture than a farm home situated out on the bare prairie, unprotected and besieged by the fierce storms of winter, I have failed to see it. Turn your stock out amidst such a scene, when the wind is blowing a gale, and they stand shivering till they are put back in the stable again. It has been demonstrated times without number that ten below zero with the wind blowing a gale, is worse than forty below without wind.

The moral is: Plant trees, and lots of them, around your farm homes, and you will never regret it.

In a great many instances people have lived on the bare prairie for twenty or thirty years without planting any trees; or, if they have made the attempt, it has ended in partial or total failure, due in most cases to poor methods of handling or subsequent cultivation. Think of the beauty and comfort they might have been enjoying all these years had they planted intelligently when they first settled. And this would have been a vastly different looking country to-day.

In order to be successful, the beginner on the bare prairie must plant only those trees that have proven entirely hardy, such as the Russian willows, box-elder (or Manitoba maple), green ash, white elm, and white birch. Plant these hardy trees on the outside of your proposed plantation, and after they have grown a few years and have become somewhat of a shelter, plant, on the inside, at least a few rows

of some of our hardier evergreens, such as the white spruce, Colorado blue spruce, jack pine, lodgepole pine, Scotch pine, balsam fir, and native cedar. For, after all, there is nothing like the evergreens either winter or summer. In planting evergreens do not plant them closer than twelve or fifteen feet from the deciduous trees, or they will be overshadowed and will not do well.

In order to produce best results, your wind-break should consist of at least a dozen rows of trees on the north, west and south of your farm buildings, leaving it open to the east. Be sure you leave yourself sufficient space within the enclosed area for your farm buildings. If you plant your trees too near the buildings, they will catch and hold the snow where it is not wanted. In my experience it is always best to plant three or four rows of willows about one hundred feet north, west and south of your proposed plantation. This will catch and hold the snow in the intervening space; consequently your inside trees will not be broken down by the weight of snow, a circumstance which quite frequently happens. This open space between the trees will make an ideal garden or potato patch.

## PREPARATION OF LAND.

It is of utmost importance that we have our land in first-class condition before any planting is done. Just here is where most of the failures in tree-planting on the prairie have taken place. Remember moisture is the factor that spells success first, last, and all the time. We must strive to conserve all the moisture we can in the soil, both before and after planting. There is nothing quite as good as a well worked summer-fallow, plowing it as deeply as possible. I find it pays to summer-fallow two years in suc-

cession before planting. ...Never, under any circumstances, should any planting be done on soddy land or in stubble. Be sure your land is comparatively free from weeds of every description before planting, as it is much easier to get after this pest before than after planting.

#### METHOD OF PLANTING.

In all our planting for wind-break purposes, we should aim to get forest conditions in our plantation as soon as possible. Consequently we should plant the trees close together at first, so they will completely shade the ground in the shortest possible time. From thirty years' experience in tree-growing in this climate, I have found that about four feet each way is the right distance apart to plant at first. After they begin to crowd, some of them can be removed, but right here is the severest test of the forester's skill in knowing what trees to remove and what to leave. Never open up your young forest so that the sunlight can strike directly on the forest floor, as weeds and grass will start to grow, and this will be the beginning of the end of your young forest.

I have always had the best success when using young stock in planting—about two-year-old seedlings of the green ash, white elm and maple. As all the willows grow readily from cuttings, it is not necessary to have rooted stock for planting.

Always carry your plant material in pails, partly filled with muddy water and never allow the roots to become dry. You must take special care in handling all evergreens in this respect as a few minutes exposure to the sun and wind will kill them. Always plant your trees an inch or so deeper than they stood in the nursery, and be careful to pack the earth very solidly about the roots. A little care just here will often make the difference between success and failure.

Your trees should have thorough cultivation, and be kept free from weeds and grass until they completely shade the ground, when forest conditions will be established.

Build a good substantial fence around your forest to keep out all stock. Remember, there is no room for a successful tree plot and farm stock on the same piece of land. There are a great many natural groves in the west to-day being ruined by this practice. Take good care of your young shelter belt and in a few years you will think it is the most valuable asset on the farm.



A NEW BRUNSWICK ELM.

Mr. Hunter White, Secretary of the New Brunswick Wholesale Grocers' Guild, writes the Forestry Journal, enclosing the above photograph of an elm growing at Lower Norton, near Hampton, N.B., on the Kennebecasis River. Quite truly Mr. White remarks: "We have an idea that elms do not grow finer in any other place in the world than in New Brunswick."

#### MAKING WHITE PINE GROW.

Mr. Hill, lockmaster at Buckhorn, Ont., experimented with a pine tree to determine improved growth which may be secured by proper care. Fifteen years ago, he pruned all the lower branches off a 4-inch white pine sapling, removing other saplings from its vicinity, dug up the earth around it and applied manure to its base. It is now 19 inches in diameter at its base and has a long, clean bole. Thus, during the 15 years, the growth in diameter has averaged one inch annually.

#### CANADIAN TREE SEED FOR BRITISH PLANTATIONS.

Twelve hundred pounds of Sitka spruce seed have been collected by Mr. B. R. Morton, of the Dominion Forestry Branch during the summer's work near Massett Inlet on Queen Charlotte Islands, B.C. Each pound contains about 250,000 seeds. The entire shipment will go to the Board of Agriculture for Scotland and will be utilized by the British Forestry Commission for replanting purposes. The seed was extracted on the Island and was cleaned at Kamloops.

## ITEMS FROM THE DIARY OF OUR EXHIBITION CAR

The Canadian Forestry Association's Exhibition Car, which is a travelling school in forest protection and the value of the forest possessions to the Canadian people, completed a short tour of the prairie provinces during October and November under the able direction of Mr. R. M. Watt, of the Dominion Forestry Branch, Dauphin, Manitoba.

Mr. Watt was forced to battle against inclement weather throughout the trip which, of course, interfered with public attendance. Nevertheless the journey accomplished a great deal of good educationally, and it is hoped will be resumed next season.

A few of the items from Mr. Watt's diary of the trip read interestingly:

Gladstone, Man.: Representative attendance from town as well as scholars with teachers, who showed keen interest in exhibit.

Swan River, Man.: Succeeded in getting 85 per cent of the people in Swan River to see the car. School children came with teachers.

The Pas, Man.: Public and separate schools and teachers and representative business men visited car and showed great interest. Splendid attendance.

Melford, Sask.: Raw cold day. Splendid attendance. Bankers and business men showed keen interest, also a number of people from the country.

Shellbrook, Sask.: Arrived at noon. Excellent attendance.

Saskatoon: Busy all day and till 10.30 p.m. Good attendance, practically all business men.

Stettler, Alb.: Good attendance at car both from schools and town.

Big Valley, Alb.: Would say at least 95 per cent of population visited car. Between Big Valley and Munson had a number of visitors while train was running.

Drumheller, Alb.: Handled over 300 people, who were very interested.

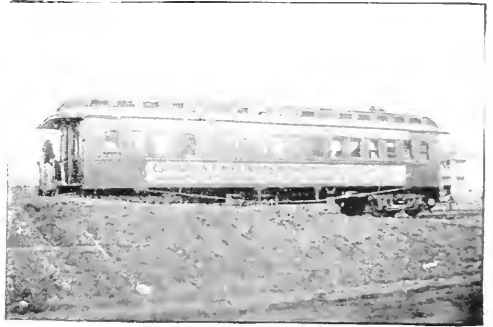

And so the record continues.

Next season, the Forestry Association will endeavor to improve its Forestry Car by more elaborate construction of models and a more diversified arrangement of forest products. In fact, we hope to have two cars in operation, east and west. The Association's handicap in this important enterprise is purely one of finance, the present Forestry Coach, even with its limitations, having been outfitted and sent forth on its mission only with considerable difficulty as regards the provision of funds.

### FROM WINNIPEG.

"I trust that the efforts of the Forestry Association may bear fruit. Few can realize the extent of the loss already sustained by this country in this matter, and it will take constant and untiring work to impress on those in authority and the public at large, whom they represent, the urgent need of a constructive policy."

G. B. McCOLL.

*Land Surveyor and Engineer.*

### PREMIER DRURY ON FORESTRY.

From Toronto *Star* report of an address by Premier Drury before the Canadian Club at Toronto:

"A progressive forestry policy is to be inaugurated by the new Government with a modern scheme of reforestation. New Ontario must be wisely developed," he said. "In the past our treatment of forest resources has been criminal," declared the Premier.



Northern Ontario's Forest Wealth. A log jam along the T. & N.O. Railway.

## THE LINE-UP OF LAND IN SASKATCHEWAN

The following has been worked out for the Canadian Forestry Journal as a reasonable division of the land area of the province of Saskatchewan, which totals one million acres:

One-third prairie, south of the main line, C.N.R.

One-third wooded, between main line of C.N.R. and Churchill river.

One-third barren, north of Churchill river.

This, of course, does not indicate absolute lines for there are considerable agricultural areas inside the wooded zone as well as a certain amount of natural forest land in what has been designated as prairie. However, the tabulation will stand as substantially correct, thereby indicating that only thirty or forty per cent at most of the entire province of Saskatchewan is adapted to agriculture.

Of the fifty million acres inside the central section south of the Churchill river, it would

probably be a most conservative estimate that 25 to 35 million acres are absolute forest land, quite unfit for farms. The present area of the forest reserves in Saskatchewan is six million acres which falls short of including even one-quarter of the provincial area that must be handled for timber production or be regarded as permanent barrens.

As illustrating the enormous reduction in the standing timber of Northern Saskatchewan it may be pointed out that only 750,000 acres out of 25 to 35 million acres of natural forest land are to-day bearing commercial timber. The economic effect of this reduction in raw materials has already been seen in the closing of the largest sawmills of Saskatchewan and the prospect of still further reduction of sawmill activities. It is estimated that when logging and sawing in Northern Saskatchewan was at its height about \$2,000,000 a year was circulated in pay envelopes and supplies through such points as Prince Albert.



# THE UTILITY OF THE WINDBREAK

By Carlos Bates, in "Windbreaks, Their Influence and Value."

The term "windbreak" may be applied to any object which serves as an obstacle to surface winds. For the purposes of this study, however, it must be limited to bodies or rows of trees. Windbreaks may be divided according to their general arrangement into three classes: (1) rows and hedgerows; (2) belts or shelter belts; (3) groves, or, in the most extensive case, forests. A belt usually consists of three rows or more, but its width is less than twice the ultimate height of the trees.

In European countries the windbreak perhaps serves its greatest utility as a check upon drifting sands along the coast, especially in France. In the interior steppes of Russia, which correspond to our middle western plains, windbreaks have been planted more or less extensively to protect fields from the desiccating winds of the region. In Schleswig-Holstein earth walls are thrown up and shrubbery is planted upon them, since forest trees can not be made to grow there.

## WHERE TREES COUNT MOST.

Although windbreaks are of very real benefit to the farmer and fruit grower everywhere, it is in the treeless, wind-swept plains that they find their greatest utility. In addition to the esthetic benefits and the general "improvement" value to the farm, it would in many instances be almost impossible to raise crops without protection from the hot, dry winds of summer and the cold, dry winter winds.

The early settlers realized the value of trees for protection and attained success in tree-planting under conditions which at first seemed very unfavorable. First, small groves were planted about the houses and barnyards. Gradually these were extended in the form of belts or single rows to protect the larger areas of orchards and fields. Where the soil was light it was necessary to prevent its drifting. The farmers soon found also that a windbreak was very useful in preventing the drifting of snow. Railroad companies made many desultory attempts to protect their tracks by planting belts of trees far enough away to serve as snow traps, but more frequently loose fences were used.

Orchards must be protected from the mechanical effects of the winds which strike the trees when they are laden with fruit; from their drying effect, which blights the fruit and causes it to shrink; and from the drying or "winter-killing" of the branches. This applies not only to the prairie states, but also to the lake states, the fruit region of California, and the Columbia river valley fruit region. In many sections of Michigan, Wisconsin, Illinois, Maine, and New York, where peach growing was formerly profitable, it is now impossible to raise consistent crops of this fruit, because of the increased exposure that has resulted from the removal of the original forests.

## FOR WHEAT AND RYE.

It is necessary to consider also such winter crops as wheat and rye. For the protection



An irrigation lateral on C.P.R. lands in Southern Alberta.

of these the windbreak serves the double purpose of causing an even distribution of the protective snow cover and of sheltering the tender plants from the wind itself, once the snow has melted. The protection of all summer crops is important.

The protection of stock is a matter of no small importance in many of the western states, where there are large ranches with no more

adequate shelter for the cattle than that afforded by a grove of trees. Instances have been recorded where large herds of cattle have passed through a severe winter in the shelter of a cottonwood grove. Such a condition represents a low state of development in the economy of the stock business, but the usefulness of a windbreak for the protection of sheds and winter yards may always be considered.

## CAN WHITE PINE DISEASE BE CONTROLLED ?

That the white pine, most valuable of American soft woods, can be saved, and not made extinct by the dreaded blister rust, was the consensus of opinion at the international blister rust conference in Albany, when experts from all parts of the country gathered to discuss means of stopping the spread of the infection. If proper care is taken to prevent its spread there is no reason why reforestation with white pine should be discontinued. Methods of treatment of the infected tree, but particularly of stopping the carrying of the spores to uninfected trees were discussed. Dr. L. H. Penning-

ton, head of the Forest Pathology Department of the New York State College of Forestry at Syracuse, told of important tests in the Essex county region, to determine the distance to which the disease could be carried, and he gave his opinion that the blister rust spores were able to carry the infection to a much lesser distance than has commonly been supposed, thus making the protection of uninfected stands of pine much simpler. He urged that the greatest care be taken, however, to completely eradicate the current and gooseberry bushes which participate in transmitting the pest within the danger zones.

### THE PINES.

By Douglas Malloch, *The Lumberman Poet.*

Calm, unafraid, they face the storm,  
The pines upon the hill,  
The winter cold, the summer warm,  
With an unaltered will;  
And winds may blow  
And waters flow  
Or all the earth be still.

Their years are centuries, their lives  
Span many lives of men;  
And mortal fails or mortal thrives  
Or mortal fails again,  
But on the steep  
Their watch they keep  
O'er rock and rill and glen.

Would we might stand, as stand the kings  
Upon the mountain side,  
Above the level—little things,  
Ambition, sorrow, pride;  
Would we were these,  
The giant trees  
Whose souls have never died.

God give me strength to be a pine  
And not to be a weed,  
To lift my head and give no sign  
However I may bleed—  
To face the years,  
To hide the tears,  
To be a pine indeed.

### SACRIFICE VIENNA FOREST

Paris, France.—The actual fuel shortage in Austria has resulted in mutilation of the famous Vienna forest by the desperate population, according to despatches from the Austrian capital. So many trees have been cut out that restoration of the forest is considered impossible, the despatch said. The government has been unable to restrain the people from obtaining fir wood from the forest.

### BRITAIN'S PLANTING PROGRAMME.

According to official information received by the Canadian Forestry Association, the British Forestry Commission has now been appointed and the sum of three and a quarter million pounds sterling has been appropriated by the British Government for reforestation enterprises over a period of ten years. This allows approximately \$1,750,000 per annum. About 250,000 acres will be planted with forest trees.



A LOVELY TREE FOR CANADIAN GROUNDS IN WINTER TIME  
View shows a European Larch in December. It is particularly well adapted to these surroundings and parks.

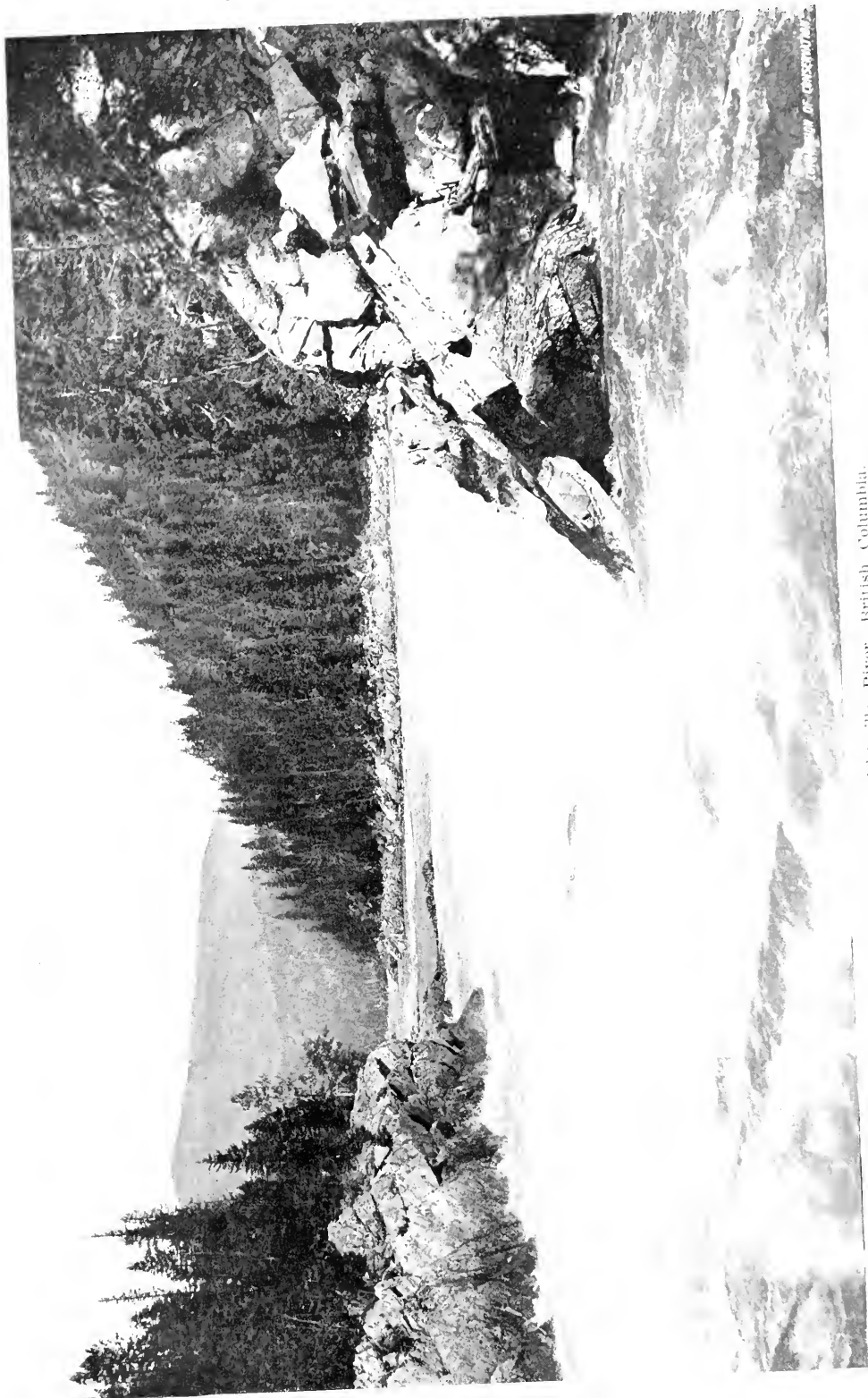

On the Pen d'oreille River, British Columbia.

Copyright of Casselman

# PRACTICAL UTILITY OF PLANES IN FORESTRY

By J. B. Harlin, Commissioner of Dominion Parks.



## Would an Equal Investment in Forest Wardens Achieve Better Results in Fire Prevention?



Practically everyone who has to do with forestry is convinced that eventually aircraft shall be extensively and efficaciously used in such work. Expectations in that connection concern two broad lines—the rapid and accurate collection of information in regard to the forests, extent and variety, topography and fire protection. Everyone is familiar with the wonderful detail and accuracy of the war maps prepared from aircraft photographs. Such accurate and detailed maps are absolutely necessary for the intelligent handling of Canada's forests. Such can be prepared by the laborious and expensive and slow land survey methods, but the airplane appears to offer facilities for securing perfectly satisfactory maps at a trifling cost and in a period of time measured in days instead of years.

However, it is in regard to fire protection that most is expected of airplanes. After all is said and done fire protection is the most important feature of forest work from the practical standpoint. No one will deny that reforestation of cut-over areas is essential if the annual yield is to be sustained. It is true, natural reproduction can be depended upon in some localities to replenish the denuded areas, whether denuded by fire or by man. Certain studies relative to the scientific management of the forest from a commercial standpoint are also necessary, but after all the practical man will recognize that fire being a constant menace, it is of no avail to reforest and carry on the various other steps in regard to scientific forestry if the organization of methods and appliances for protecting the forests—new or old—from fire are inadequate.

Forest fire protection to be adequate requires prompt discovery of fires, facilities for promptly transporting men and appliances to the scene of a fire, and finally adequate means of effectively extinguishing fires.

"CATCH THEM YOUNG."

Prompt discovery is a first essential. A forest fire in its incipient stage is comparatively

easily handled. A forest fire which has developed into a large fire is one of the most difficult problems a man can face. As to discovery, there can be no difference of opinion as to the utility of aircraft for this purpose. The methods now followed in connection with fire discovery are: The maintenance of patrols of men—afloat or mounted—and a constant observation of an area from look-out stations—either on mountains or on high towers. The use of aircraft undoubtedly will eventually supercede these methods. Each of these methods has its own peculiar advantages. The moving patrol can, as a rule, cover larger areas than a look-out; the look-out may do its work more intensively than the moving patrol, but its limits are definitely fixed by the topography of the country. Aircraft should be able to take the place of both these services. They combine the motion of the man patrol and the intensity of the look-out station. In effect, they will become moving look-outs.

The area which such a look-out station can efficiently cover can be measured in hundreds of square miles, while the area of a fixed look-out station, or a man, or a horse patrol can cover, is figured only in tens. Another item of superlative advantage is the altitude of an airplane compared with an ordinary look-out station. There are naturally very distinct limitations to the height that a fixed look-out can reach. There are practically no limitations to the airplane in that regard. The ability of the airplane to rise to great heights, it is true, enables it to overlook at all time a much greater area than that covered by a fixed look-out. Important as this is, it is, perhaps, not the greatest. Especially in the mountains, fires frequently make headway before discovery because of high elevations intervening between the look-out or the patrolling warden and the fire, and because of the great variations in the direction of the wind, caused by the topographical features of the country. The worst fire in the Dominion parks this year was burning several days within a comparatively

few miles of a patrolling warden before discovery. There, unfortunately, was a high range between him and the fire, and the wind was so deflected that it was impossible for the warden to see the smoke. The first reports of the fire came from the prairies, miles away. From there the smoke was clearly visible. Even when the general location of the fire was known and fire-fighting gangs were sent in, these people could see no sign of fire until they were within a few hundred yards of it. Now, had there been an air patrol the fire would have been discovered the day it started. To a person unfamiliar with the mountains this story might seem almost impossible, but a most rigid investigation has established its truth.

#### THE SQUARED MAP.

Once a fire is discovered, the all-important matter is to definitely locate it so that the fire-fighting gang may reach it promptly. The "squared map," so much used in the war, offers facilities for an airman exactly locating a fire and passing on word to the fire-fighting organization, also in possession, of course, of a "squared map." And that means that the fire-fighters at once know where to go and how. This information may mean the saving of many valuable hours in the beginning of the fight against the fire and a few hours at that time may mean the difference between the destruction of a few acres of forest and the destruction of tens or perhaps even hundreds of square miles.

There is another important use of these maps in regard to fire-fighting. The maps give accurate information as to the conformation and physical features of the district. As already intimated, these have an important bearing on wind direction—a vital consideration in fire-fighting. These also constitute the chief considerations in the decision as to how a fire is to be fought. From an accurate map the fire-fighter at once knows whether the fire threatens specially valuable timber. He also knows whether there are any natural features, rocks, water, open areas, which can be used as a natural line of defence against the fire. This and other information he can get from the maps gives the fire-fighter the knowledge he requires in reaching a decision as to how to lay out his fighting forces. For it must be remembered that fighting a battle with a fire is like fighting a battle with human beings. Generalship is vital, and when a general knows all about the "lay of the land" where the battle is being fought he has information that may readily

mean the difference between a victory and a defeat.

#### SCOUTING A RAGING FIRE.

There are two other matters in connection with forest fire protection in which it is expected that aircraft may help materially—rapid transportation of men and supplies to the scene of the fire, and scouting operations during the progress of a fire. As to the scouting operations, these are of great importance if a fire attains any great size. A man who is directing fire-fighting operations in such a fire is always handicapped by lack of information concerning the developments of the situation. His staff may be holding the fire at one point, but losing ground at another. Topographical features and consequent variations often give a fire an unexpected turn. An airplane scout, observing the fire from aloft, can keep the chief fire-fighter constantly advised in that connection.

As to transportation of men and supplies, everything that aircraft can do in that regard will prove of outstanding value. As already stated, getting the fight started before a fire has gained too much headway is all-important. Getting fire-fighters to a fire even only ten or fifteen miles away is often a slow and laborious undertaking, for forest trails are not city highways, and, moreover, forest fires have a disagreeable habit of so locating themselves that the first struggle of the fire-fighters is to get over the steep grades and the masses of debris and to penetrate the thick forest growth between them and the fire. It is obvious that with ample landing-places throughout a forest, the airplane can very quickly take men and supplies to the scene of a fire.

#### ARE GAS BOMBS PRACTICAL?

It is to be hoped that the airplane will also prove effective in actual forest fire-fighting. At present the idea in this connection is that airplanes may be used for dropping gas bombs on the fire. The idea is perfectly reasonable if a gas can be found which will prove an effective fire-extinguisher in the open air. There is a vast difference between using a gas extinguisher in a building and in the open air. Outside, the diffusion of the gas is so rapid that it is comparatively ineffective. Here is a job for a chemist. If he can produce a gas bomb that will extinguish fires in the open air, there is no doubt that the airplane affords the quickest and best means of applying it to the fire.

The utility of aircraft in forest protection appears to be so obvious that it is no doubt a matter of surprise to airmen and to the public

## Forest Fires at Last Conquered by Aerial Salt-Shakers?

Salem, Ore.—A plan to sprinkle salt on the clouds to produce rain, which would curb the forest fire menace, was offered to Governor Olcott in a letter from J. J. Boyce, of Portland. Boyce would have the salting done from airplanes. The Governor did not declare himself in favor of the idea, but was reported to be considering the scheme to equip airplanes with

salt-shakers. Boyce, in his letter, called the Governor's attention to the fact that in flying one passes through zones where there is moisture in the air, but not enough to condense and form raindrops. Common salt would draw this moisture, if dropped from high above such an air current, Boyce maintained. He hazarded the opinion that clouds and rain would result.

that they are not to-day in universal use in Canadian for ests. Yet the fact is that they are not in universal use, and from present appearances, not likely to be in universal use for some years to come. Some patrol work carried on this summer by the St. Maurice Fire Protective Association (Quebec) represents practically all that has yet been done in Canada in the matter of forest air work. The main reason that aircraft are not in universal use is because no satisfactory answer has yet been given to the question, "Will it pay?" Or, to put it another way, "If a definite amount of money is to be spent on fire protection, will the best results be obtained by spending it on aircraft or on fire wardens?"

### MEN OR MACHINES?

Those responsible for fire protection are so far not at all convinced that best results will be obtained by spending it on aircraft. To illustrate: An estimate of cost prepared last spring for aerial patrol of a certain forest area in Quebec worked out approximately at \$23,000 (this did not include any provision for wireless.) This estimate was prepared without taking into account any expenditure in the purchase of machines, the intention being that machines should be borrowed from the Government. It did not take into account various other items, such as the construction of housing for the machines, depreciation, interest on the investment, workshop equipment, etc. Now, the figure of \$23,000 was intended to cover two four-hour patrols per day on an average of twenty days per month for a period of six months. With the same amount of expenditure on wages for fire wardens, a fire protective service would be able to employ for six months at \$100 per month practically forty wardens. Those concerned in fire protection work naturally ask the question: "With forty wardens, wouldn't we get better results than with the aircraft patrol?" Perhaps they would, and perhaps they

would not, but that is the question that, more than any other, serves to delay action in regard to the rapid application of aircraft to forest work.

Of course, in addition, there is the capital involved in the purchase of planes and other equipment; there also is the high cost of installation of wireless stations, because, to get full efficiency out of aircraft there should be wireless installations as well. To go into the business of applying aircraft and wireless to forest work involves a large capital expenditure and a large expenditure on operation.

While most people are convinced that efficiency would be promoted by an air service, the men responsible for expenditure on forestry work naturally weigh the pros and cons. They must figure on a dollar basis. They know pretty well what they can accomplish per dollar by a warden service. No one has yet given a practical demonstration as to what can be accomplished by aircraft on the dollar basis. Therefore, alluring as the prospect of a forestry air service is, it would appear that the development of such service will be comparatively gradual and comparatively slow.

### PLANES ARE NOT FIRE-FIGHTERS.

There is another point in connection with this subject which also largely enters into the calculation of the forest workers: For the present the airplane is not of any value in actual fire-fighting. But an additional warden service (as in the case mentioned above, 40 wardens) would be of very distinct value in fire-fighting. Now, there probably will never be a time when no one is optimistic enough to expect that history will not from time to time repeat itself. With this in mind the forest worker will not discuss a forest air service without attaching great importance to what a large warden service can do against a fire, when an airplane would be powerless.

Popular belief in the utility of aircraft has developed from the wonderful accomplishments of the air-fleets during the war., But warfare is inevitably carried on regardless of cost. As soon as aircraft come to be applied to a commercial purpose they have to be dealt with on a commercial basis. In forest protection work a forest has a definite commercial value. Therefore there is a definite limit to what can properly be paid for protection work.

As intimated at the start of this article, most forestry people expect that eventually aircraft will be extensively used in forest work. It

seems certain the development will not take place with a rush. The value of forests is steadily rising. More and more attention is being given to their conservation. And more and more attention is being given to the utilization of new methods and appliances in that connection. It is not unreasonable to anticipate a complete revolution in forest fire systems and not unreasonable to expect that just as the fire warden is the main prop of forest fire protection to-day—discovering the fires and putting them out as well—the airplane will in the future do exactly the same work and do it more efficiently.

---

## PROGRESSIVE LIMIT-HOLDERS READY TO PLANT

---

Those readers of the Forestry Journal on the lookout for signs of progress in the application of forestry principles to the timber lands of Canada will have a special interest in recent developments in Quebec Province. In a conference with the Minister of Lands and Forests, Hon. Horace Mercier, an able and progressive administrator, the Woodlands and Technical Sections of the Canadian Pulp and Paper Association, together with the Quebec Limit-holders' Association, discussed the whole question of the revision of regulations governing the cutting of timber on public-owned forest lands. It was argued, with great reason, that the present diameter limit method of regulation is based upon a desire of Canadian Governments in the early days to leave sufficient trees on cut-over lands to provide a timber stock for the ultimate farmer. Such a regulation was made in a day when many lumbermen were cutting on lands destined to prove of agricultural value. Very little of the present day timber cutting is on other than non-agricultural soils so that the diameter limit does not have its original justification. Furthermore, adherence to a blanket diameter limit irrespective of local conditions, has not worked out in the public interest in that it has failed to leave the cutting areas in a condition to produce a second crop of wood.

### A PLAN TO REPLANT.

The meeting also discussed the conditions under which denuded Crown lands could be reforested by co-operation between the limit-holders and the Provincial Government. It was sug-

gested that legislation should be adopted encouraging licensees to plant forest trees upon areas of more than 10 acres deprived of coniferous timber. A special license would be issued in each case, planting to be undertaken within four years of issuance. Tree species would be limited to spruce and pine of all varieties. Four years after planting it is suggested the payment of one dollar per square mile shall vest the lessee with the absolute property of the land occupied under his license for 99 years and any after cost of the planting shall be refunded to the lessee by the Government. All land occupied or patented under the reforestation law should be free from all provincial, municipal and school taxes of any kind during the existence of the planting licenses. For any timber taken from the plantation by the lessee in the course of thinning for improvement purposes, the stumpage taxes would not exceed \$1.50 per cord. The lessee would have the right to clean cut the plantation after the trees had attained a diameter of six inches at 4½ feet from the ground, the stumpage tax payable to the Government not to exceed \$1.50 per cord.

Following the meeting with the Minister a committee was appointed to prepare definite recommendations to the Provincial Government. The members of this committee are W. Gerard Power, manager of the River Ouelle Pulp and Lumber Co., Robt. P. Kernan, of the Donnacona Paper Co., and Ellwood Wilson, Forester of the Laurentide Company.



# PRAIRIE TREE PLANTING IS GOOD BUSINESS

*Toronto Globe Editorial.*

For three successive seasons, in certain parts of southern Saskatchewan and Alberta, conditions have been such that the farmers have failed to secure a crop. Many of the recent settlers in these areas have come almost to the end of their resources, and have neither the means nor the will to continue. Recent heavy rains which have broken the drought—unhappily too late to benefit the wheat crop—may enable owners of live stock to secure enough coarse grain and pasturage to carry their animals through the winter, but at the best the loss will be very serious, and, despite the prevalent and infectious optimism of the west, there will be a disposition to pull up stakes in those parts of the region afforded by the crop failure that are not assured moisture by irrigation.

While the failure this year has been due to lack of rain at the critical part of the crop season, much of last year's loss was the result of high winds which, after the grain had been put in under fair conditions, swept over the bald prairie, dried out the surface of the soil, and caused it to drift like the sand before a desert storm. In both cases belts of trees would have proved invaluable, for there is no doubt at all that forest growth not only conserves moisture, but that it has much to do in moderating the strength and direction of the winds. In a former geologic period the Canadian West was densely clad with forests, for the whole country is underlaid with coal that could have been the result only of forest growth. It was a country also of great swamps and watercourses, which provided sustenance and shelters for the saurian monsters, the remains of which are found in the Red Deer Valley and elsewhere, and that when restored and put on exhibition in natural history museums compel our wonder.

The puny efforts of man cannot renew the tropical humidity of the Alberta and Saskatchewan of that far-distant period, but forest growth should be done. Vast sums have been spent on opening up the country and providing it with railways and the facilities for growing and marketing grain. That great investment must clearly be followed up by forestry operations on a large scale.



CUTTING A NEW ROAD IN BRITISH COLUMBIA  
Note how carefully the debris is piled for burning  
in the centre.

Temporary expedients to set upon their feet settlers who have lost all through crop failures are all very well in their way, but they will in the end prove far more costly than a well-considered project extending over a long series of years providing for the planting and care of trees in the semi-arid regions. If this is not done there may be a reproduction on this continent of the tragedy of southwestern Asia, where the destruction of the forests has produced and perpetuated aridity over vast stretches of a region that was wonderfully fertile and provided with unfailling supplies of moisture. In Sheistan at this moment, "the wind of a hundred days" blows over arid and

sun-baked land that, when clothed with forest verdure, supported a swarming population, as the ruins of its cities prove.

**Let us plant trees in the West for the benefit of the generations of Canadians there, and whose future prosperity is largely in our hands.**

## CANADA AND ITS NEIGHBOR'S WORRIES

The attitude of a large section of United States lumbermen as to the need of better forest management is expressed in a resolution unanimously adopted by the Western Forestry and Conservation Association. Unlike the Canadian Forestry Association, the "Western" body is a co-operative society of limit-holders dominating the wood-using industries of Washington, Oregon, Montana, Idaho and California. The resolution introduces the proposed programme of H. S. Graves, Chief Forester of the United States, "as the most constructive and statesman like treatment of the subject we have seen and we urge lumbermen and foresters alike to accept it as a basis for discussing future co-operation."

The application of Col. Graves' Forest Policy to the Pacific forest region was summarized by Mr. T. T. Munger as follows:

1. A public classification of all existing cut-over lands and of other lands as fast as they are cut-over in order to segregate those suitable for agriculture or pasturage and those primarily most valuable for production of timber.

2. Financial assistance to private timber-owners in the cleaning up of fire hazards such as slashes and the protection of cut-over lands.

3. Provincial co-operation between public fire protection funds and the private owner who undertakes to practice forestry on his timberlands.

4. Stricter enforcement of fire preventive laws.

5. A radical modification of the present tax system so that the owner may not be obliged to pay heavy annual taxes while the immature forest is still unproductive.

Readers of the Forestry Journal will note that the problem facing United States foresters and lumbermen is not primarily the chief obstacle to the advancement of forestry in Canada. The discussion at present being carried on in the United States hinges upon ways and means by which the private owners of the nation's chief timber supply can be persuaded to

adopt some of the rudiments of constructive forest management. Canadians have cause to be thankful that the ownership of about ninety per cent of the Dominion's forested lands has been persistently retained by the state, thus establishing public authority in forest conservation over practically the whole of the country's timber assets.

### IMPERIAL FORESTRY CONFERENCE.

An Imperial Forestry Conference has been called by the British Government through the Board of Forestry Commissioners, recently appointed, to be held in London, England, in July, 1920, at the same time as the British Empire Timber Exhibit. A letter received by the Canadian Forestry Association from Mr. A. G. Herbert, Secretary of the Interim Forest Authority, states that invitations will shortly be addressed to the chief officers of Provincial and Dominion Government Forest Services in Canada, and to individuals prominent in the forest conservation movement. A letter from Lord Lovat expresses much interest in the forthcoming conference and assures those Canadians attending the conference of a hearty welcome.

### A QUESTION AND ANSWER PAGE.

The Forestry Journal commences next month a new department in which the questions of our readers will be gladly answered. Discussion of any interesting point is invited. The Journal will undertake to secure authoritative judgment on all queries submitted by readers or their friends.

Please avail yourself of this new department which should prove of lively interest to all.

## TIMBER SCALERS IN PERMANENT EMPLOY

In the Forest Service of New Brunswick, all timber scalers are in the permanent employ of the Provincial Government. This is in contrast with the prevailing practice in Ontario. Says G. H. Prince, Provincial Forester at Fredericton:

"One of the main duties of the forest service is to secure a correct return of the logs cut from Crown lands, and when it is stated that usually there are 700 or 800 camps and the cut exceeds 200 millions and 500,000 ties, it is seen that it is considerable of a task.

Each ranger is furnished with complete plans of the Crown land in the district assigned to him, and he is held responsible for the proper count, scale and return of all material cut from these lands each year. He is furnished with an assistant or counter, who assists him during the

scaling season. About 5,000,000 feet is considered sufficient work for any scaler. Each camp is visited every two weeks and the yards of logs counted and scaled, marked and numbered. A report is furnished the Crown Land Office every two weeks on the logs scaled and counted at each of the 700 or 800 camps in operation. This report is checked and a duplicate mailed at once to the licensees, so that he is properly informed of any infractions of cutting regulations, such as cutting undersized timber, too high stumps. If the licensee disputes the scale the logs are still there and a check scaler is put on and the dispute immediately settled. This system, tried out last season, has given very satisfactory results, and will be in use again this year, with only slight modifications.

## "EDUCATIONAL" PATROL TO MATCH FIRE FIEND

*By E. T. Allen, Forest Economist, Western Forestry and Conservation Association, Portland, Oregon.*

At every one of our annual meetings for ten years we have boasted of the effectiveness of our western forest fire protective work. We calculate the percentage relation of our losses to the total timber supply guarded and it looks pretty good. Our methods and organization have improved every year. If they hadn't, forest fires would have about cleaned out this western country by this time.

### GROWTH OF POPULATION HAS INCREASED HAZARD.

People don't realize this. They don't understand that the growth of population and industry throughout the forests has so multiplied the fire hazard, while labor, cost, and other difficulties have so hampered our defense, that it is really a great achievement to have held our own so well. The truth is that a tremendous forest area with a dry summer climate is being developed; consequently filled with fire-spreading activities of every kind, until it is becoming the world's greatest fire trap.

### TEACHING THE PUBLIC ITS INTEREST IN FOREST PROTECTION.

We began ten years ago a campaign fairly well divided between doing our own part and teaching the public its interest in helping. By

various educational devices we did a great deal to improve public sentiment. Better fire laws were passed, better appropriation obtained, and more care with fire was observed. We have perfected organization, equipment and methods of detecting and fighting fire until we do more, no doubt, with the money and men we have than any one else does anywhere.

### NOT ON TOP OF THE FIRE PROBLEM.

We have been, but it is getting too strong for us again, so we must go to the public. In other words there must be a fire rally.

### SOUND THE ALARM!

Not enough money is being spent to safeguard life and property. There must be better state and federal appropriations.

FIRE LAWS MUST BE MADE TO MEAN AS MUCH AS

### LAWS AGAINST OTHER CRIMES.

There must be officers to enforce the forest laws and indifference must not shelter the guilty. This whole subject must be brought before the people, legislatures and Congress, so it gets the attention it must, if this country is not to go up in smoke some day.

THERE MUST BE MORE CARE WITH FIRE AND  
GREATER EXPENDITURE OF PUBLIC FUNDS.

Private, state and federal forces in our own territory should be put behind a western programme, dealing systematically with Weeks Law and other Congressional needs; with state legislation; with law enforcement, and with the part which should be played by the lumber industry and the public.

FOREST PROTECTION NOT A WESTERN PROBLEM  
ONLY.

Interest in fire prevention and reforestation is showing signs of awakening everywhere. Never before has there been such a discussion of an American Forestry Policy. We should co-operate with all agencies to keep this agitation alive and before the public; emphasizing always that fire prevention comes first.

FOREST FIRES COST PUBLIC MILLIONS.

Forest fires are costing the west five or six million dollars every bad year. It is absurd to think all this fire is necessary. Much is preventable. I would almost guarantee for one per cent of five million dollars, I could make such a noise on the subject that we would practically reduce fire to lightning and incendiaries; jail most of the latter, and get enough federal and state money to eat up the fires that occur in spite of all. We cannot raise this one per cent ourselves, but I believe we can afford to do enough to make others join us.

PUBLIC HELP NECESSARY.

In short, just as we originally led the field in protection publicity, and as we now lead it in protection methods, let us realize that we are again where public help and money is necessary, and let us lead the field in going after this help.

## THE STORY OF PAPER

*By Job Taylor.*

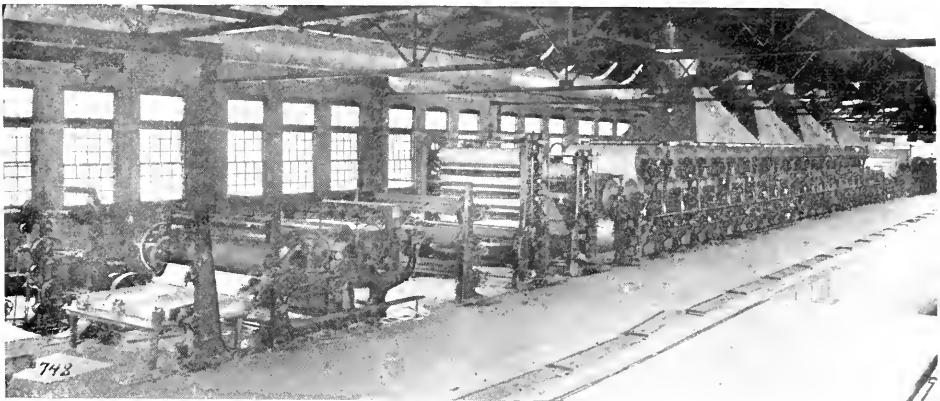

A modern paper making machine.

Backward as we are accustomed to consider the Chinese race, the art of making paper from fibrous material is known to have existed in China away back 200 years B.C. This became available to the western world in the eighth century A.D. over a thousand years ago. At Samarkand, a city between the province of Bokhara and Turkestan in Asia, a battle took place between the Arabs and the Chinese. This place was dominated by the Arabs and the Chinese made the attack in 751 A.D. The Arabs nursued them and took a

number of prisoners who taught their new masters the art of making paper from vegetable fibres. At this time the crescent had cast its shadow over the best of Europe. One boom tipped the straits of Gibraltar, from there it swung over the northern shores of Africa and dipped again at Constantinople. So the Arabs governing most of the western world introduced rapidly this Chinese art of making paper. The oldest recorded European document on paper is the deed of King Roger of Sicily in the year 1102. The Arabs made their paper largely out

of flax and some cotton, in Persia, and later in Europe out of rags.

That which revolutionized the manufacture of paper cheapened it, and put it within the reach of every one, was the invention of a machine for grinding wood to reduce it to pulp fibres. This was patented in Germany by Voelter in 1844, and later in the United States in 1858.

When paper made largely from wood fibre was introduced, the publishers would not use it. Pearson C. Cheney, who was governor of New Hampshire from 1875 to 1877, testified before the Senate Committee of Education and Labor about fifty years ago that when the pulp mill was built at Franklin, the paper manufacturers predicted ruin to the owner. As a last resort when no publisher would use it, this wood paper was substituted by the manufacture on a Boston paper order unknown to them. When the Boston paper sent in another order, the old regular paper was sent and immediately the publisher complained and requested the wood paper, though at that time knowing it was wood. This paper was used six months before they knew its constituents. Since the publishers found that wood papers worked better in the presses, from then on it had established itself.

In addition to the grinding of wood, there is another very important and essential process which helped to bring paper within the reach of all. Its principle was discovered by accident. One day a tramp papermaker was crossing the country. The sun was high in the heavens and the day was torrid. The heat became intense and so he sat down to rest in the first shady grove he reached. While he was cooling off he noticed a hornet's nest in the tree above, presently a piece of the nest fell down. He picked it up and found it to be composed of very tough fine fibres. His curiosity was aroused and he watched the hornet go to an old fence rail. He then went to investigate. He soon found the hornet was getting the strong fibre from the old rail. His papermaking instinct brought him to the thought that it would be possible to reduce the new green fibre in trees by chemicals in a short time as nature had done by years of oxidation. This, then, gave the world the chemical pulps.

#### PRESERVING ROOF TIMBERS.

Roof timbers in buildings where high humidity is the rule have been a source of trouble

to operators of paper and cotton mills, and other industries, because of their tendency to decay rapidly. In order to determine the best means for preserving such timbers, the Forest Products Laboratory at Madison, Wis., has conducted a series of tests of the various treatments. As a result, it was recently announced that the pressure method, with either creosote or a zinc-chloride solution, will give better results than steeping, dipping, or painting. Twenty years may be added to the life of the wood by this treatment, it is declared, though it is admitted to be the most expensive. Each cubic foot of timber should receive 8 to 12 pounds of creosote, or half-pound of zinc chloride, if the latter is used.

#### WOODEN SHIP 46 YEARS ON DUTY.

In view of the discussions that have taken place during the last year or two with regard to the seaworthiness and durability of wooden ships it is interesting to note the case of the famous old revenue cutter Bear, belonging to the United States coast and Geodetic service, which recently completed its thirty-third annual cruise to the Arctic. This vessel was built on the Clyde, Scotland, in 1874, as a steam whaler, but was soon acquired by the United States Navy Department, and first came into public notice through being used by Commander (later Rear Admiral) W. S. Schley on the Greeley relief expedition in 1884, as a steam tug. The name of the old vessel has frequently appeared in print in connection with its various voyages to the Arctic and other strenuous service. It seems almost unnecessary to argue the durability and seaworthiness of properly built wooden vessels in view of the proud record of clipper ships before the days of steel construction and steam navigation.

They made stout wood ships forty-five years ago and they still make stout wood ships. When someone pipes in with a slur upon wood ships and their alleged unseaworthiness it might be well to mention the old Bear, now in its 46th year and not out of the hale and hearty class, despite her years of bucking Arctic ice and gales.

## THE FOREST FIRE WARDEN

*From the Christian Science Monitor.*

Like the keeper of the light in a lonely tower anchored to the rocks possibly fifty miles off the coast, the warden of the forest, particularly in the mountainous sections of the northeastern part of the United States, keeps his lonely yet interesting vigil. As the keeper of the light is versed in the lore and traditions of the sea, so the sentinel in the forest tower reads and interprets the language of the woods and forests. He knows the mountain paths and byways, can tell, at a glance, the geographical position of every hill in the distance, and can point out and name the score or more of villages hidden in the valleys behind sheltering trees or intervening ridges. In his months or years as a ranger or travelling supervisor, he has learned the topography of the region over which he watches, and is able to read it as he would read an open book. But he has other aids, of course, and is not compelled to depend entirely upon his memory. In the centre of his observation tower will be found a circular map, showing in detail the topography of every acre of woods and forest land within his district.

The extent of this district varies, of course, the area depending upon the range of vision possible from the tower, which is naturally placed upon the highest point available. Practice in observing and "locating," supplemented by the right kind of knowledge, makes it possible for the towerman to indicate, by reference to his map, approximately the exact point at which smoke or fire appears. Previous information furnished by the local fire warden may have assured the sentinel that the smoke may come from a brush fire made by a farmer or woodsman in clearing land, or from the campfire of a tourist or hunter. Lacking these assurances, the towerman acts promptly and effectively. With his telephone in the lookout tower, he calls, in a moment, the deputy nearest the point under observation, with the result that the fire is stopped before any considerable damage results. These details, furnished by the local warden, are recorded, along with such other facts as are regarded important, in the towerman's logbook, to be in turn submitted to state and federal authorities.

A casual visit to the quiet observation tower of a warden in the great wooded sections of the New England states, for instance, perhaps on a

day when the clouds are low and the thin mists from the coast are idly drifting inland, may convince an uninquisitive sightseer that his quest has been vain, if he has come in search of the unusual and exciting. But if the visitor has known the lighthousekeeper, the prototype, in many ways, of the quiet man who sits in the warden's tower, or if he has himself, at some time, lived and dreamed dreams in solitary places, he will not find it difficult to persuade his host to talk. It has been said, and no doubt truly, that those who talk little quite often say much. Perhaps they say much because they talk only of the things about which they know much. So, at any rate, it seems to those who listen to the quiet story which the towerman tells of his work and his experiences, of the co-ordinate efforts among states and federal departments for greater efficiency in the important undertaking in which he and others are engaged. He seems, almost unconsciously, to speak the language of the forests and mountains, not in dialect or colloquialisms, but in the language of the man of books and of the vast open places, where expression is free and men are unafraid. The story has ended in the hour which has quickly passed. Within that hour there has apparently been wrought a strange but unmistakable transformation. Where sat the towerman, one, perhaps, of a legion of his fellows, sits a sage, a scholar, a teacher.

### A BREAK-PROOF 'PHONE LINE.

The construction of the forest protection telephone lines in New Brunswick is proceeding satisfactorily. About 22 miles have been built, leaving 18 more to construct in order to reach the Bald Mountain Lookout Station. Since the arrival of snow the transportation of wire and provisions has been rendered much easier. The construction party consists of seven men and necessary teams. Mr. H. C. Kinghorn is in charge. The line is being built in the most modern method of tree construction. Tie wires are stretched across the road between opposite trees; the main telephone wire is attached to the tie wires by split insulators in such a position that it remains suspended over the centre of the portage and about 15 to 18 feet from the ground, very similar to the method in which

# Northern Electric

## POWER AND LIGHT

Electric Plants for Every Service  
350 to 5,000 watts.

Especially adapted to camps—saw-mills—  
construction work—stores—farms and all  
country houses.

This cut shows the Utility model  $\frac{3}{4}$  K.W.  
usually furnished with storage battery, but  
obtainable as a one-piece generating unit.

Its features include: Bosch Magneto—  
S.K.F. Ball Bearings—Electric Governor—  
and concealed Flywheel—it is self-cranking  
and stops itself when battery is charged.

*Northern Electric Company*  
LIMITED

Montreal  
Halifax  
Ottawa

Toronto  
London

Regina  
Calgary

Edmonton  
Vancouver  
Winnipeg

## Foresters' Equipment

MOSQUITO AND INSECT PROOF TENTS

WATER AND MILDEW PROOF BAGS

FROST PROOF SLEEPING BAGS

ALL "WOODS" QUALITY

## Woods Manufacturing Co.

DEPT. D.

OTTAWA

**TREES, SHRUBS and SEEDS**

HARDY NORTHERN TREE STOCK

**EDYE-DE-HURST & SON, DENNYHURST**

DRYDEN, ONT.

Shippers to H.M. Government.

**GAGNON & MORISSETTE**TIMBERLAND CRUISERS  
LUMBER CONTRACTORS  
FOREST INDUSTRIES

CHICOUTIMI, - - P.Q.

**Hill's Seedlings & Transplants**

ALSO Tree Seeds for Reforesting. Best for over half a century. Immense stock of leading hardy sorts at low prices. Write for price list and mention this magazine. Forest Planters Guide Free.

**The D. HILL NURSERY CO.** Evergreen Specialists  
Largest Growers in America.  
Box 503. DUNDEE, ILL., U.S.A.**LT.-COL. L. J. D. MARQUIS**Forest Engineer and Mem. Can. Soc. of F.E.;  
Quebec Assoc. of F.E.; Former  
Mem. Que. F. ServiceTimber Factors and Logging Costs  
Facts on Forest Growth and Future Products  
Forest Cruising and Mapping  
GIFFARD, - - - - QUEBEC.**Try This Stump Puller  
at Our Risk**The 8ml Stump Puller will take out every tree and stump by the roots, clearing from one to three acres a day, doing the work of twenty men. We want you to send for our 3 year guarantee against breakage and our free trial proposition. Address  
**W. Smith Grubber Co.**  
11 Smith St.  
LaCrescent, Minn.**Timber Lands Bought & Sold**

Timber and Pulp Wood Estimates.

**R. R. BRADLEY**

CONSULTING FORESTER

Globe-Atlantic Bldg. - ST. JOHN, N.B.

ASK



FOR

**Timber Estimating & Mapping**Management of Forest Properties.  
Supervision of Lumbering Operations.  
Forest Planting.**COOLIDGE & CARLISLE**

FOREST ENGINEERS

BANGOR - - - - MAINE.

**Timber Estimates**

JAMES W. SEWALL

Old Town, Maine.

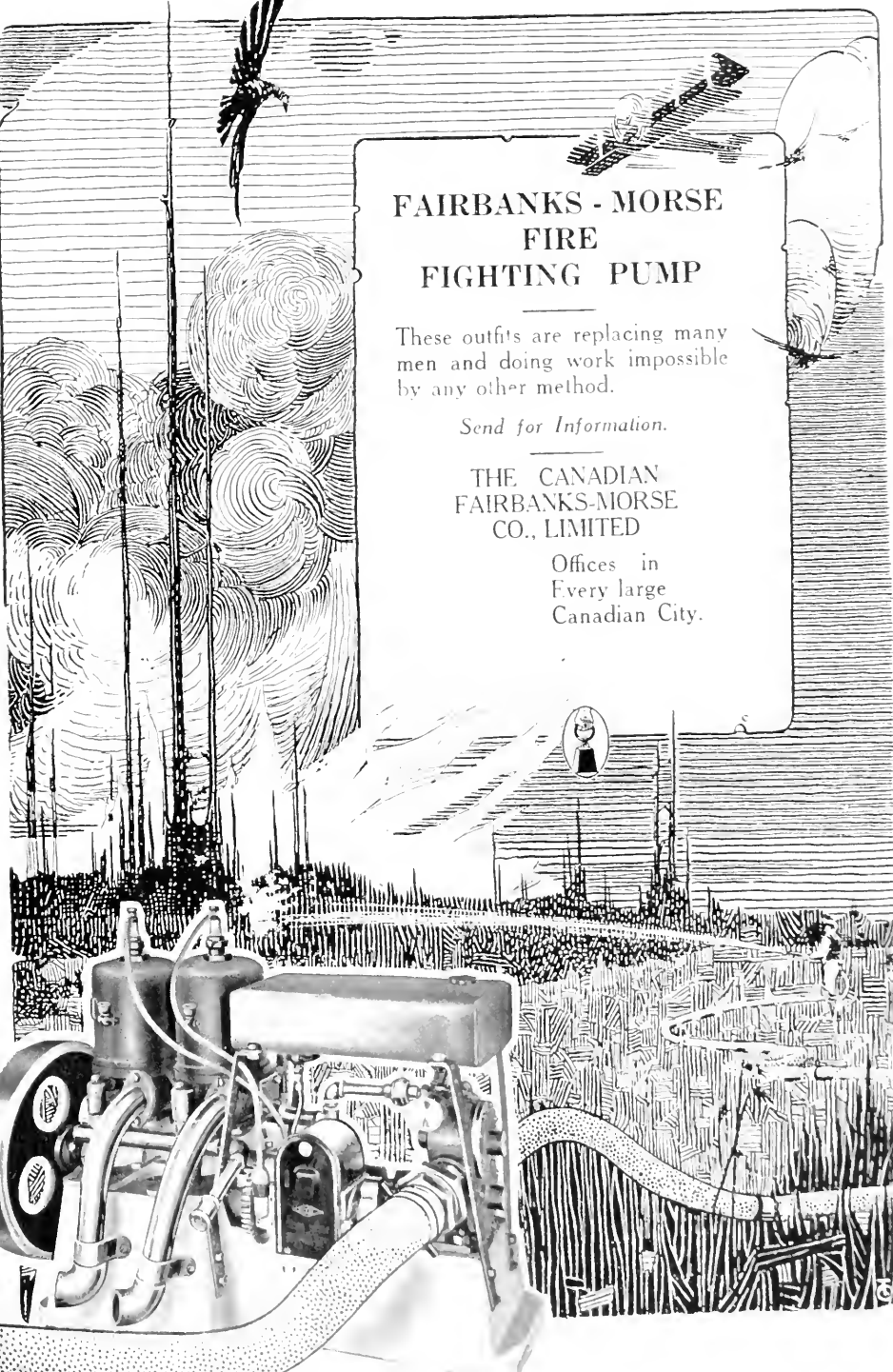

A detailed woodcut-style illustration of a forest fire. In the foreground, a Fairbanks-Morse fire fighting pump is shown in profile, with a hose extending from it. The pump has a large flywheel on the left and various mechanical components. The background shows a forest with several trees, some of which are on fire, with thick smoke rising into the sky. A large eagle is perched on a branch in the upper left, and another eagle is flying in the upper right. The scene is framed by a decorative border.

## FAIRBANKS - MORSE FIRE FIGHTING PUMP

These outfits are replacing many men and doing work impossible by any other method.

*Send for Information.*

THE CANADIAN  
FAIRBANKS-MORSE  
CO., LIMITED

Offices in  
Every large  
Canadian City.

a trolley line wire is supported overhead in the middle of a street. The wire is thus kept free from contact with the brush on each side of the portage road. Any overhanging branches are trimmed off with a special tree trimmer which easily removes branches up to 2 inches in diameter. The main line is kept reasonably tight by being snubbed to a tree by a strain insulator once every half-mile. Sufficient slack is left in the wire to allow several trees to fall across it and bring the main line to the ground without breaking it or its supports. When the fallen tree is cut out the line springs up to its place. If the main line is not broken messages may be sent over it even if several trees are lying across the wire. Telephones are being installed at convenient points about ten miles apart.

## LUMBERMEN ATTENTION!

Investigate our new patented towing and holding boom. Will save its cost many times over in preventing logs going adrift while being towed in open water, or for booming swift running rivers where logs are held.



Cut shows tug crossing Bay Chaleur with over 2,000,000 in tow. Distance 35 miles.

A. E. LOOSEN,  
BATHURST, NEW BRUNSWICK



**QUEEN'S**  
**UNIVERSITY**  
KINGSTON,  
ONTARIO

**ARTS**  
Part of the Arts course may be covered by  
correspondence.

**MEDICINE      EDUCATION**  
**APPLIED SCIENCE**  
Mining, Chemical, Civil,  
Mechanical and Electrical  
Engineering

**SUMMER SCHOOL      NAVIGATION SCHOOL**  
July and August.      December to April  
26      GEO. Y. CHOWN, Registrar.

## FORESTER WANTED

*for*

## NEW ZEALAND

A Chief Inspector of Forestry is required by the New Zealand Government. Salary £600 per annum, increasing to £700. Candidates should be graduates of a School of Forestry of recognized standing. Full particulars and forms of application obtainable from the High Commissioner for New Zealand, 415, Strand, London, by whom complete applications will be received up to the 20th January, 1920.

## TABLE OF CONTENTS FOR DECEMBER, 1919

|   | PAGE |
|---|------|
| Ontario Must Face These Facts Now. By Robson Black.....       | 483  |
| Maple Sugar Pays Quebec a Yearly Fortune.....                 | 491  |
| Programme for Private Forestry .....                          | 494  |
| Forestry's Birthday 1,000 Years Ago.....                      | 497  |
| An Odd Study of Tree Stumps. By C. C. Pemberton.....          | 498  |
| The Value of Prairie Windbreaks. By M. J. Stevenson.....      | 503  |
| Line Up of Land in Saskatchewan.....                          | 506  |
| The Utility of the Windbreak .....                            | 507  |
| Can White Pine Disease be Controlled?.....                    | 508  |
| Practical Utility of Planes in Forestry. By J. B. Harkin..... | 511  |
| Progressive Limit Holders to Plant.....                       | 514  |
| The Story of Paper.....                                       | 518  |
| Facts for the West to Deal With.....                          | 526  |

The Forestry Journal will be on your neighbor's desk every month—if you subscribe for him. One dollar a year.

206 Booth Building, Ottawa.

WANTED  
**LIGHT RAILS**

State whether complete with splice or angle bars.  
Give size, quantity, location, condition and best cash price f. o. b. cars loading point.

Box No. B, Canadian Forestry Journal, Ottawa, Can.

**B. M. McGRATH**

Colonial and Industrial Investments,  
Timber, Pulp Wood Areas and  
Waterpowers.

Newfoundland and Labrador  
Mines and Minerals.

*Reports, Plans and Estimates Furnished*

TRADE REVIEW BUILDING,  
ST. JOHN'S, NEWFOUNDLAND

**Victor Portable Stereopticon**

(Complete weight 11 lbs.)

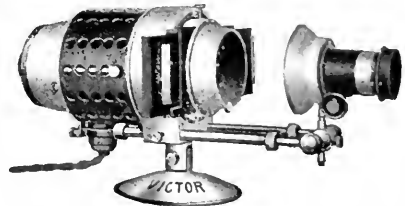

THE "VICTOR" will use  $3\frac{1}{4} \times 4$ , or  $3\frac{1}{4} \times 3\frac{1}{4}$  Lantern Slides. Price \$65.00.

When required for educational or religious work, price \$50.00.

Can be used with any electric current, or supplied for use with Acetylene and Prestolite Tanks.

*Write for Complete Catalog.*

**SUPPLIES COMPANY  
OF CANADA  
LIMITED**

65 SPARKS STREET,  
OTTAWA, ONT.

## FACTS FOR THE WEST TO DEAL WITH

(From the Manitoba Free Press)

That one path of future prosperity in Manitoba lies in developing the enormous possibilities in timber and pulp wood growing was explained to a special meeting of the Winnipeg bankers' and mortgage companies' managers yesterday afternoon by Robson Black, Secretary of the Canadian Forestry Association. Mr. Black addressed a meeting at Young Church Sunday night, and spoke again at Grace Church last evening, with motion picture illustrations. A total of ten meetings have been held in Winnipeg.

Forestry, said Mr. Black, is the science of obtaining maximum profits from a great natural resource. It is concerned with growing repeated crops of timber on non-agricultural soils; 75 per cent of Manitoba is under tree growth and not more than 35 per cent of the whole provincial area will ever pay a profit to the farmers' plow. One-third of Saskatchewan and Alberta are adapted by nature for the growing of profitable crops of timber. The timber and pulp wood of Manitoba, therefore, is the largest crop in point of acreage, and in view of the experience of such provinces as Quebec and New Brunswick and nations like Sweden, it offers incredibly great potentialities.

"Since Confederation the forest areas of Canada have been responsible for over 1,500 million dollars of export trade as compared with 2,000 million dollars received for cereal crops. This year pulp and paper exports alone from the spruce growing sections of Quebec, Ontario and to a smaller extent from British Columbia have jumped to 120 millions, as against 120 dollars in 1890 a million times as great."

### THE PROFIT IN CONSERVING.

Mr. Black told how spruce areas in United States and Canada were making enormous rises in value. Forty million newspapers a day are produced on this continent and this publishing industry alone makes prodigious demands upon the very limited sources of spruce wood supply. Several American newspapers stripped from 15 to 30 acres of forest for each Sunday edition turned out. The Winnipeg daily papers were consuming probably 250 spruce and balsam trees with each day's run. Coupled with the

lumbering industry the pulp and paper industry had shown the old time phrase of "exhaustless forests" to be nothing short of undiluted moonshine. These industries in the eastern States and Canada were now coming forward with schemes which approximated scientific forest management. The day of forest butchery must end or the country ceases to be an international competitor. The history of the lumbering industry has been one of a continuous chase of virgin timber supplies from county to county, east to west, and north to south. President Dodge, of the International Paper Company, recently declared that there were not to-day two stands of spruce in eastern America that would justify the erection of two fifty-ton pulp mills. In eastern United States the last stand of the great American lumber industry was now being made in the south after stripping Maine, Wisconsin, Michigan and other lake states. The president of the Southern Pine Manufacturers has declared that 3,000 mills under his jurisdiction will go out of business in ten years because of exhausted forests.

### LOSING FORESTS RAPIDLY.

Turning to Canada, the speaker showed that the forest resources in the three prairie provinces except for the areas in the forest reserves, are in a state of progressive deterioration. Eighty per cent of the west's original inheritance of splendid forests has been destroyed by forest fires in recent times. Mr. Black declared that few, if any, lumbermen and pulp company executives in eastern America were any longer deluded by the old fiction that unregulated logging at present in vogue throughout the Dominion will do anything but destroy the capital values of a timber area. Hence European practice now centuries old which looked upon a timber tract as a source of permanent timber crops was now being adapted to American and Canadian conditions. As far as the three western provinces are concerned this calls emphatically for the handling of the public-owned timber berths by the Dominion Forestry Branch, which is the Government's only technically qualified department.

IF YOU WANT A CHEW  
THAT WILL JUST SUIT

YOU ASK FOR

**STAG**

**CHEWING TOBACCO**

RICH AND SATISFYING.

IT IS ALSO KNOWN TO BE  
"EVER-LASTING-LY GOOD"



## Do You Require More Capital?

For ten years, Royal Securities Corporation has been associated with the development and financing of Canada's most successful pulp and paper enterprises. Among them are:

*Abitibi Power and Paper Company.*  
*Brompton Pulp and Paper Company.*  
*Mattagami Pulp and Paper Company.*  
*Price Bros. and Company.*  
*Riordon Pulp and Paper Company.*  
*Fraser Companies, Limited.*  
*Donnacona Paper Co., Limited.*

Do you desire to pay off floating indebtedness; increase your plant capacity; or acquire additional properties? If so, why not let us suggest ways of financing your requirements? Our Engineering and Correspondence Departments are at your disposal.

**Royal Securities**  
**Corporation**  
**L i m i t e d**  
MONTREAL

TORONTO

HALIFAX

ST. JOHN

LONDON, ENG.



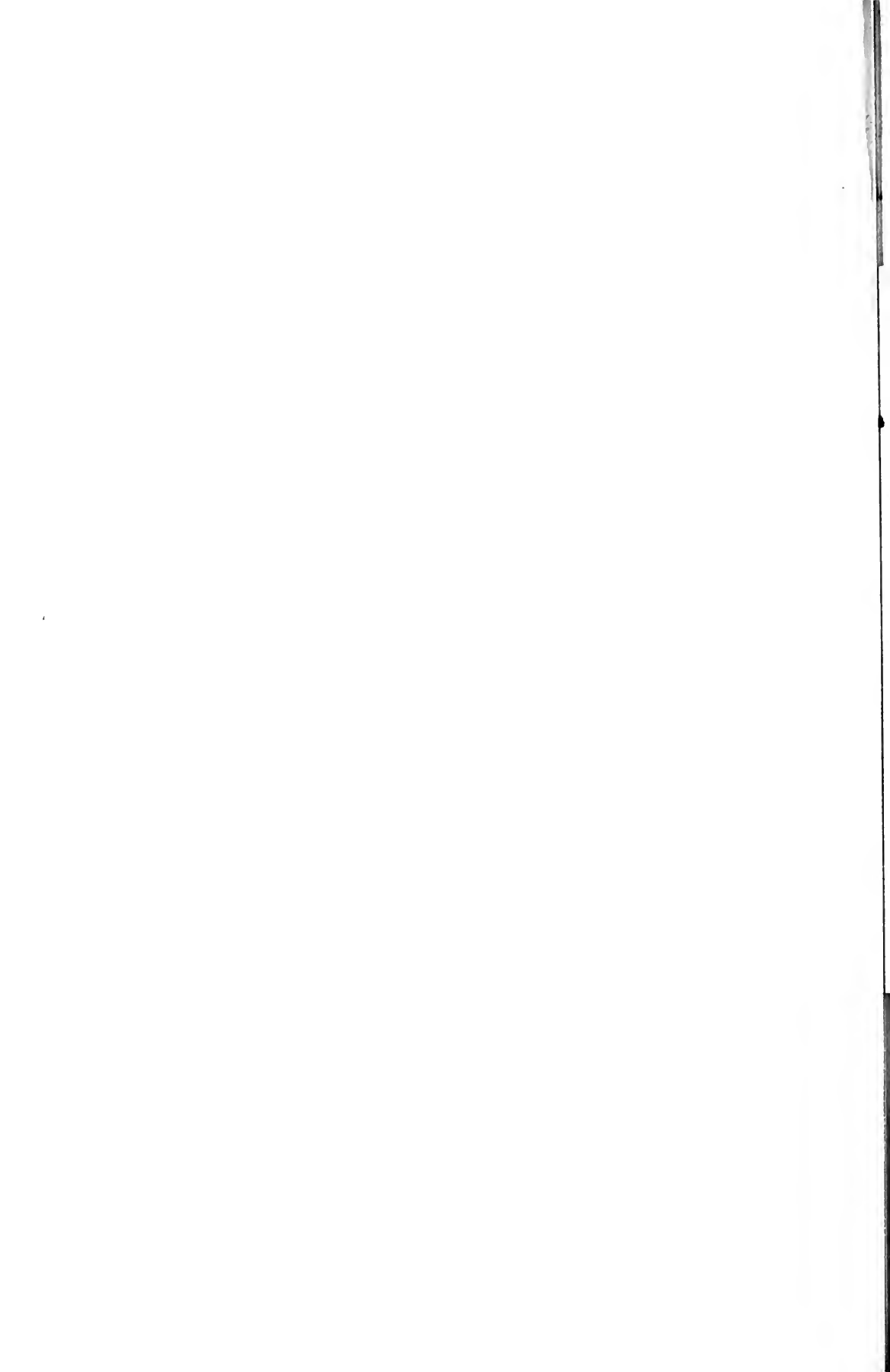



Author Canadian Forestry Journal

Title 15 - 1918<sup>9</sup>

| DATE.       | NAME OF BORROWER.           |
|-------------|-----------------------------|
| File 80/34. | D. Crabbey                  |
| Dec 29/58   | Dean Sisson                 |
| Jan 7/60    | J. B. Sisson                |
| 14. 6. 89   | Katherine Miller. Geog 5070 |

University of Toronto  
Library

DO NOT  
REMOVE  
THE  
CARD  
FROM  
THIS  
POCKET

Acme Library Card Pocket  
Under Pat. "Ref. Index File"  
Made by LIBRARY BUREAU

