

Digitized by the Internet Archive
in 2008 with funding from
Microsoft Corporation

P.
Technol.
Engin. Dept.

25219
Vol. VI. 1910 - Jan - Dec Nov 1-12-10 LIBRARY



Why five years?

Because within the past five years there has been an unprecedented development in Canadian railroads. The steel rails have been laid north, south, east and west. The building of the G. T. P., the expansion of the C. P. R., the miles of lines of the C. N. R. under construction and the inroads of other railroads have made a demand for larger and better tools.

Because motor drive is being used more in railroad and manufacturing shops; and because (and this is probably the chief reason) there has been the introduction of new high speed steel necessitating greater driving power, wider belts and a more substantial machine.

Canadian companies have shown themselves very progressive and have improved all their standard lines as well as increasing the number of machine tools manufactured. Others have devoted their time and attention to one line, improving it to give a maximum production. Besides carrying on experiments themselves, they have watched those being made by machine tool manufacturers of other countries. The result has been great improvements in Canadian-made machine tools.

Five years ago with carbon steel a very slow machine speed was satisfactory. The fact that machines have been developed to work at a speed from 2 to 5 times that speed according to the work, tells the story of how machine tools have been redesigned and more heavily constructed.

Planers have required a great deal of attention to make them stand up to their work. A few years ago, it was recognized that finishing cuts could be taken at a higher speed than roughing cuts, but now this is reversed. The introduction of high speed steel has brought about the reversal of conditions.

McGregor, Gourlay Shaper.

Rack driven shapers are subject to these conditions mentioned for the planer. Now a slotted arm is recognized as best because the speed is reduced at the beginning and end of stroke. Fig. 1 illustrates a McGregor, Gourlay Co. 16x20 inch shaper. It gives 8 changes of speed where 4 were formerly used. It is now considered essential to have automatic down feed of tool where formerly it was a luxury.

The machine illustrated in Fig. 1 is of modern design and stands up well when using high speed steel. The ram has square slides and is worked by an improved adjustable crank and slotted lever, the length of stroke being instantly set by a dial and pointer on the operator's side of the machine, the longitudinal adjustment is made quickly and positively by means of a double thread screw. The tool block slide has automatic feed up or down at any angle. The screw of this has a micrometer index graduated in thousandths of an inch.

The cross feed screw is also provided with micrometer index, and the feed stops automatically at either end of the slide, preventing breakages through carelessness.

McGregor, Gourlay Co. Lathe.

The 20-inch lathe illustrated in Fig. 2 is built for modern steel requirements with increased belt power and variety of feeds. In increasing the width and speed of belt, difficulties have arisen in shifting. To overcome this the McGregor, Gourlay Co. designed the permanent belt shifter shown in Fig. 2. This works easily and quickly. Another point is the feeds. A few years ago 3 changes were thought to be enough, but now 50 changes of feed are instantly available.

In the 20-inch lathe shown in Fig. 2 the cone is made with three steps, large in diameter, and takes an extra wide belt, which is changed by the shifter mentioned. There are two sets of back gears which with two friction pulleys on the countershaft give 18 changes of speed in geometrical progression, instantly available. For high speed work this is an entirely satisfactory arrangement, as it gives six changes of speed for finishing and small diameters at much greater power than has been furnished, direct on the spindle from the belt. Six changes through a back gear of low ratio for roughing at a high speed, and six changes through a comparatively high ratio, back gear for large diameter.

The feeds and screw cutting changes are instantly obtainable by the movement of a lever to the different positions given on the index plate. All the gears connected with this mechanism are made of steel, and whenever running on studs are bronze bushed. It is impossible to engage either automatic cross or longitudinal feeds

117278
13 | 7 | 11

when the machine is cutting screws or vice-versa. The thread of the screw is used only for screw cutting. It is not necessary to reverse or stop the spindle when cutting screws as a dial on the saddle shows when to engage the nut. The feeds are instantly reversed in the apron by a movement of a lever. The saddle may be instantly clamped when cross feeding by a movement of a lever.

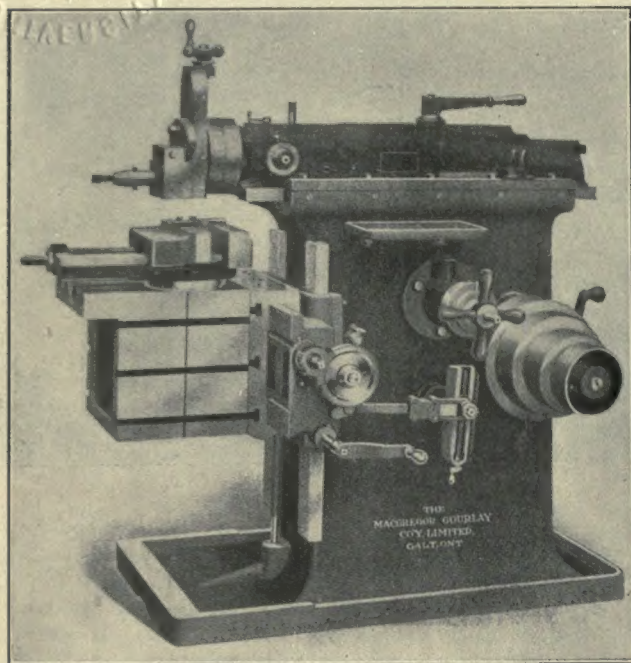

Fig. 1.—McGregor, Gourlay, Galt, Redesigned 16" Shaper.

Lathe cuts the following threads :

2, 2½, 2¾, 2⅘, 2⅙, 2⅚, 3, 3¼, 3½, 3¾, 3⅘, 4, 4½, 4¾, 5, 5½, 5¾, 6, 6½, 7, 7½, 8, 9, 9½, 10, 11, 11½, 12, 13, 14, 15, 16, 18, 19, 20, 22, 23, 24, 26, 28, 30, 32, 36, 38, 40, 44, 46, 48, 52, 56, 60, 64.

R. McDougall Co., Lathes.

The R. McDougall Co., Galt, is giving special attention to lathes and in the past two years have redesigned them so that they now have a greater rigidity so that they are more suitable for high speed steels. The head has been redesigned to give a more even progression of speed. The cone diameter has been enlarged giving greater belt contact. The lathes now do from 2 to 4 times as much as previously in ten hours.

The headstock is well ribbed, closely fitted, and so clamped as to insure its non-chattering. The bearings are made self-oiling, having deep chambers for this purpose and oil is fed to the spindles through a felt strainer which acts as a filter in clearing the oil. This filter should be renewed at least once a year and this will insure well lubricated bearings. Provision is made for return of oil

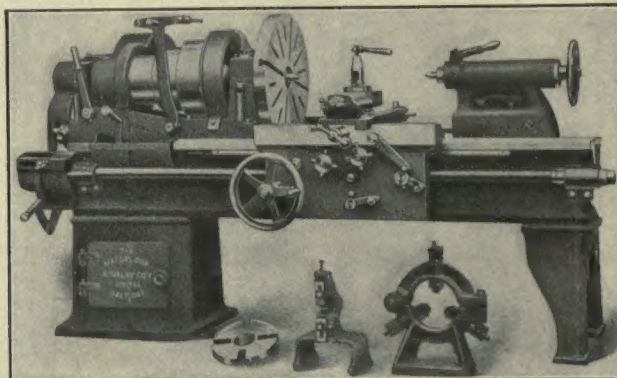

Fig. 2.—McGregor, Gourlay, Galt, Redesigned 20' Lathe.

pose and oil is fed to the spindles through a felt strainer which acts as a filter in clearing the oil. This filter should be renewed at least once a year and this will insure well lubricated bearings. Provision is made for return of oil

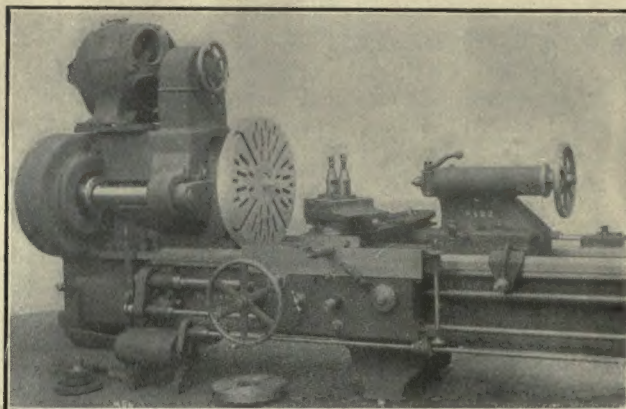

Fig. 4.—Bertram Interchangeable Lathe Fitted for Motor Drive.

to chamber, thus making oiling of spindles automatic. This is one of the new features.

The carriage and apron have been redesigned with special reference to giving the maximum resistance to the springing and straining of these important parts of a lathe. The carriage has full bearings on V's its entire

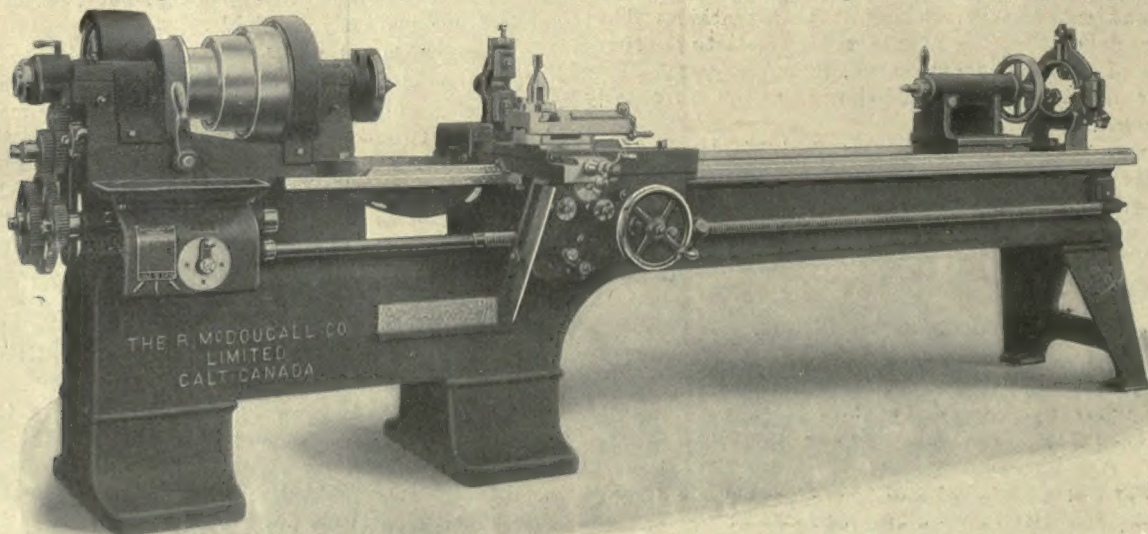

Fig. 3.—R. McDougall, Galt, Redesigned Gap Lathe.

length, has wide cross V reinforced with an extra amount of metal in cross bridge. The construction of the carriage and apron and their connection with rod and screw are so closely fitted as to prevent all tendencies to unevenness of motion or springing when under load.

The carriage brace is a special feature. This is a strong brace which is connected to the apron and slides upon a scraped and fitted way on the bed. The upper

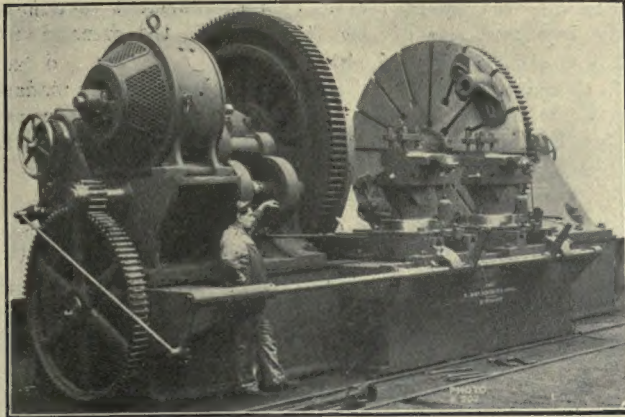

Fig. 5.—Bertram Locomotive Wheel Tire Lathe of Five Years Ago.

end is shouldered and this makes carriage very solid when working on gap diameters:

Double back gears are now used on their gap lathes and engine lathes when ordered. This feature is a very important one, especially on a gap lathe where a large range of diameters require to be treated. With two speed countershaft, as provided, 18 distinct spindle speeds are available, the ratio of advance being equal in each case so that no two speeds overlap. Through the first or low ratio gear a high spindle speed with a high belt velocity makes the lathe particularly efficient on rough and heavy cuts on small diameters, while the second or high ratio gear gives ample power for heavy

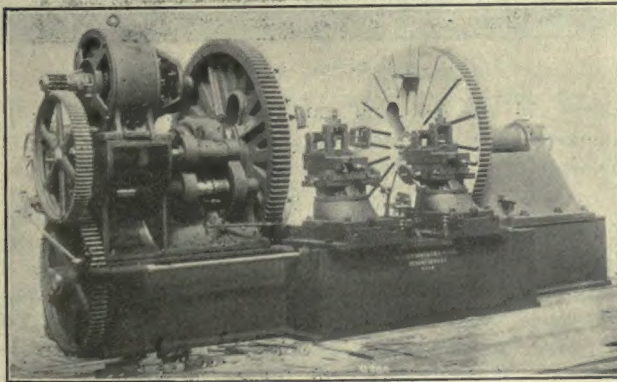

Fig. 6.—Redesigned Locomotive Wheel Tire Lathe

cuts on the largest diameters which can be swung in the lathe.

The lathes are all carefully tested, a test sheet record being kept and a copy is sent to the purchaser. The parts are made to accurate templates, and the lead screw is guaranteed being made to an exact standard master screw.

John Bertram & Sons Co., Dundas.

All lines built by John Bertram & Sons Co. have undergone redesigning. The drive on all tools, including lathes, planers, drills, etc., have been reconstructed. Planers are now built so that with the body of the planer can be placed in stock. When an order is received,

it can be arranged for motor or belt drive as desired, or for square or parallel drive, by bolting on the proper attachments. A description of this new Bertram planer appeared in the September issue of Canadian Machinery.

The lathe shown in the heading is a belt driven lathe. Fig. 4 shows the motor driven lathe. The lathes are made convertible, belt drive or motor being attached after the body of the lathe is completed, accord-

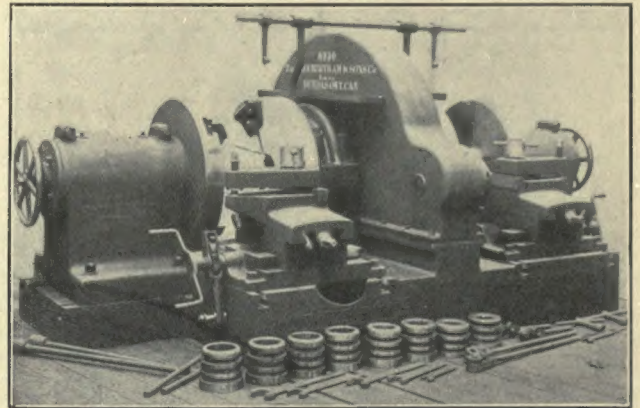

Fig. 7.—Modern Coach Wheel Lathe.

ing to specifications. In Fig. 4 the mechanism known as the "back gearing," is on the front of the lathe. Power is applied near the cut, taking the strain off the bearings. Massiveness is one of the features in the redesign of the lathe so that it stands well the strain of high speed steels.

Locomotive Wheel Tire Lathe.

Great advances have been made in railroad tools. In the Bertram locomotive wheel tire lathe several improvements have been made. Fig. 5 shows the old type

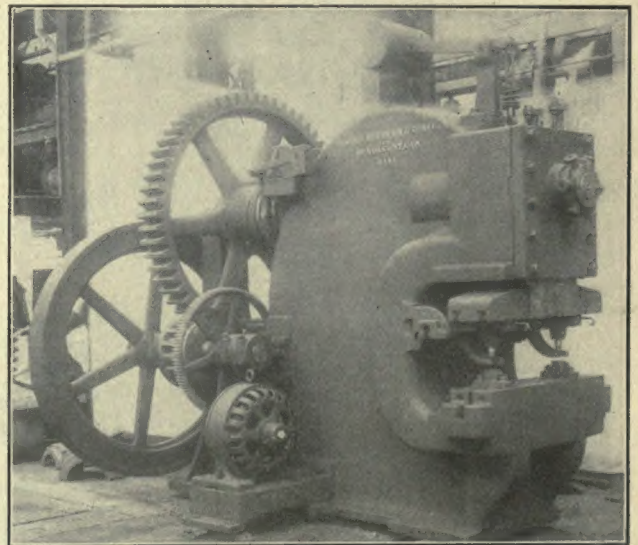

Fig. 8.—Redesigned Punch and Shears.

tool holder and method of holding wheel in place, while Fig. 6 shows the redesigned machine. In the first type the wheels were turned with an ordinary driver, now patent sure grip drivers are used, the wheel being chucked firmly to faceplate by the arms. This method is the invention of an expert of the Niles, Bement, Pond Co., and was patented in Canada by the John Bertram & Sons Co.

The tool holder used to require eight bolts and nuts but the new single screw tool holder shown in Fig. 6 reduces time. Production has now been more than

trebled, the output being increased from 3 pair to 9 and 12 pair per day.

Bertram Coach Wheel Lathe.

The coach wheels used to be driven in the coach wheel lathe from the face by boltheads, but now the same method as for tires is used. A single tool holder has also been adopted on this machine and the output has been increased from 5 or 6 to 15 pair per day.

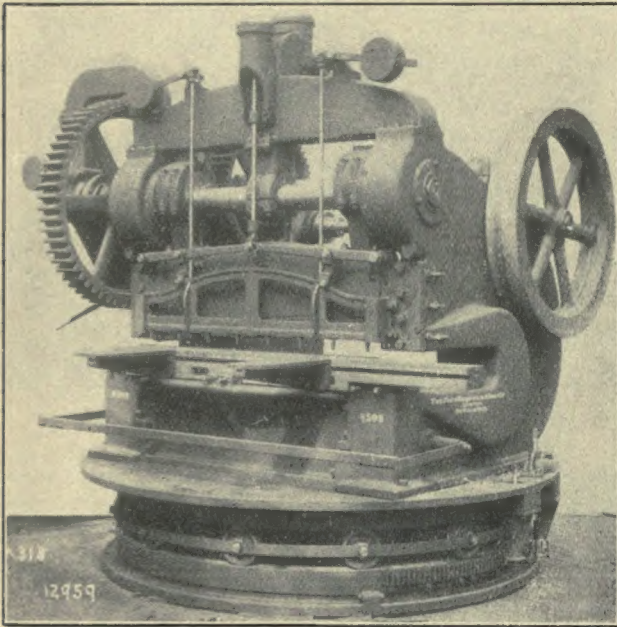

Fig. 9.—Improved Punch and Shears.

Fig. 7 shows a modern coach wheel lathe with single tool holder and modern chuck grips. This heavy tool has been developed to turn the high C. and Mg. steels. They must have great power, for on account of the climate and heavy grades, our railroads are more severe on rolling stocks than southern roads. The tires get tempered and the tools must remove these parts by cutting under the hardened parts, when truing up coach wheels.

Bertram Punches and Shears.

Punches and shears have been recently redesigned making them convertible for structural steel work. The

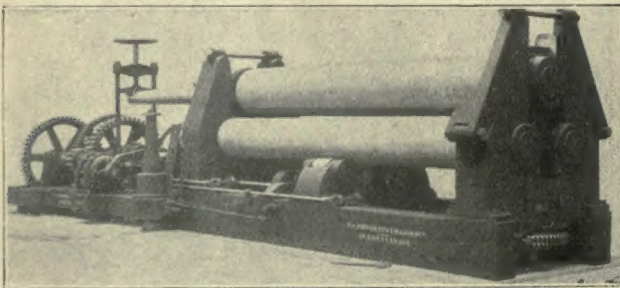

Fig. 10.—Motor Driven Plate Rolls.

one shown in Fig. 8 has a 40-inch face of ram for multiple punching. With it 12 to 15 holes may be punched at once. Formerly 8,000 holes per day used to be a good day's work, now 90,000 holes per day is considered a reasonable day's work.

Fig. 9 shows one of the latest shearing machines. Formerly the beams were worked by cams. This method was defective and when different thicknesses of plate

were used, they were not clamped equally. When it clamped thin work it would not clamp thick plate.

The shears shown in Fig 9 are equipped with clamps operated by air cylinders, which give an equal pressure on all thicknesses of plate. Another late development, or perhaps it is an old method again adopted, is to use belt drive from the motor to the shears, as the jarring of the machine gave trouble with gears.

Angle shears cut 8''x8''x $\frac{1}{4}$ '' angles where 6''x6''x $\frac{3}{4}$ '' used to be thought large. This development is due to the increased size of structures and the demand for larger structural steel shapes.

Bending rolls have been improved and with modern rolls as shown in Fig. 10. With these $1\frac{1}{2}$ '' plate can be rolled where five years ago rolls would bend up to $\frac{3}{8}$ inch only.

Hydraulic Press.

With the development in Canadian railroads there has also been a development in the hydraulic press. The machine five years ago had a single plunger pump with cast iron cylinders for wheel work. Now steel resistance, copper lined cylinders and triple plunger pumps are parts of the improved hydraulic press.

Three sizes of plungers are attached, one or all may be used, sizes $\frac{3}{4}$ inch, $1\frac{1}{4}$ inch or $1\frac{3}{4}$ inch being available.

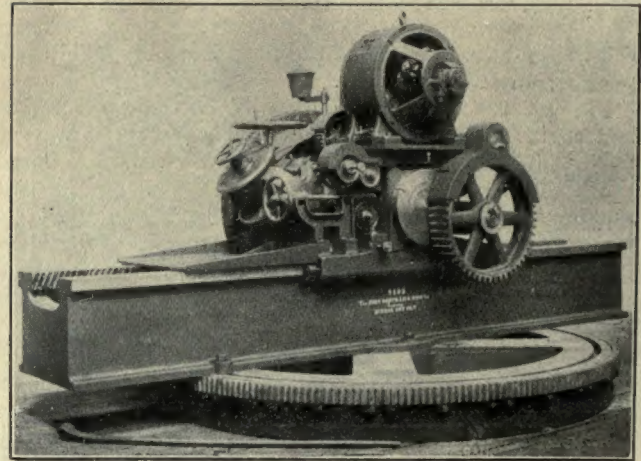

Fig. 11.—20th Century Rotary Planer.

From 150 and 200 tons was formerly considered a big machine; now 300 tons for carwheels and 600 tons for locomotive tires is used.

Rotary Planer.

The rotary planer is a development caused by the recent advances in structural steel work. The motor is mounted on the turntable as shown in Fig. 11. The first Canadian machine had a capacity of 24 inches. The company who installed the 24-inch machine is now installing a rotary planer of the same make, 67 inches in diameter. Planers are made up to 10 ft. diameter cutting head capacity.

Universal Radial Drill.

Fig. 12 shows a Bertram Universal Radial Drill, the latest product of the Bertram works, and is a new design. This machine is driven by means of a single pulley through speed box, and back gears. There are 16 changes of spindle speeds. The spindles are counterbalanced and provided with quick return. There are three changes of positive feed controlled by a pull pin conveniently located on the head.

The drill head is of the full-swing type, being mounted on a swiveling base and can be readily turned from a vertical to a horizontal position. It has lateral adjust-

ment along the arm by means of rack and pinion through a band wheel convenient to the operator.

The arm is of particularly rigid construction with vertical adjustment by power and is arranged to swivel. The inner column is rigidly bolted to the base plate and supports the outer column which rests on roller bearings, permitting easy swinging of the drill arm.

A conveniently arranged reverse lever in front of the drill head is used for tapping. The position of this lever

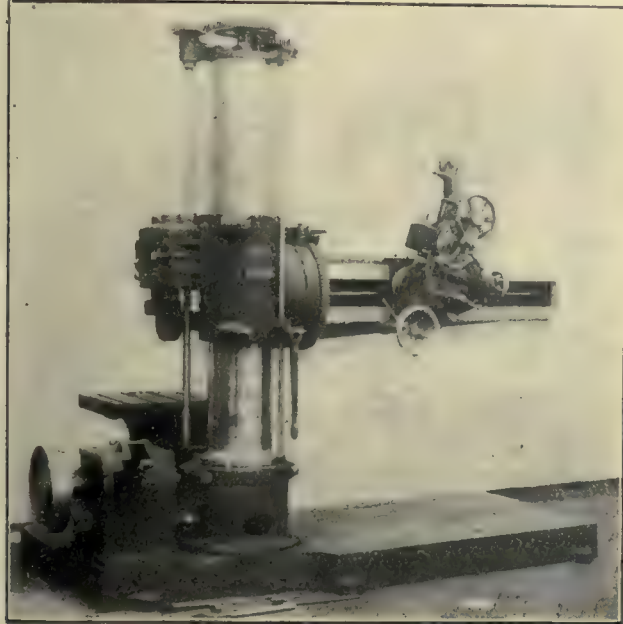

Fig. 12.—New Bertram Universal Radial Drill.

up or down indicates the direction of the spindle traverse while the drill spindle may be instantly stopped by lifting lever to central position. These machines may be readily changed from belt to motor drive at any time.

Bertram Boring Mills and Slotters.

Boring mills have been redesigned and increased from 42 to 100 inches. The Niles boring mill is built up to 20 ft.

Slotters are now made with motor drive and are convertible. Fig. 13 shows a 12-inch slotter with link slotting attachment. The worm of circular motion is disconnected and the bar is set to the circle required.

Steam hammers have also been redesigned to keep up with the demand made by the railroads for heavier locomotives and therefore heavier locomotive frames.

New Machines of Stevens Co., Galt.

About three years ago the Stevens Co. started to manufacture in Canada the Jones & Lamson or Hartness type of flat turret lathe. Although this lathe was previously manufactured in United States it is the first of its class to be manufactured in Canada.

A new manufacturing lathe of simple design was recently placed on the market. It has powerful drive, being made for use with high speed steel.

Bawden 20-inch Drill.

The Bawden Machine & Tool Co., 22 Orillia Street, Toronto, manufacture a 20 in. drill which was placed on the market about two years ago. It is a powerful drill, furnished with back gear, power feed, automatic stop and quick return.

London Machine Tool Co., Hamilton.

Another company which has made great strides in the redesign of machine tools is the London Machine Tool Co. Practically their whole line of slotters, drills, shapers, boring mills, planers, lathes and railroad machinery has been redesigned to keep pace with the demand for heavier machine tools for use in railroad shops.

Fig. 14 shows a large slotter built in 1909 by the London Machine Tool Co. In designing this slotter advantage has been taken of the largest users of slotters. The essential features in the design are the movable head and the quick power adjustments to head and to all motions of the table. Coupled with these are other improvements of extra quick return of ram, stroke indicator, automatic throw-out to feed, etc.

This slotter allows work being done requiring great reach. The quick power feature, on certain work, means an increase of 200 per cent. in output. Generally it does 50 per cent. more than the original designed machine. The machine illustrated will cut to the centre of a circle 7 ft. 6 ins. in diameter, and will cut to the outside of circle 9 ft. 2 ins. in diameter.

Heavy Wheel Lathe.

Fig. 15 illustrates a massive wheel lathe built by the London Machine Tool Co., Hamilton. All parts are designed

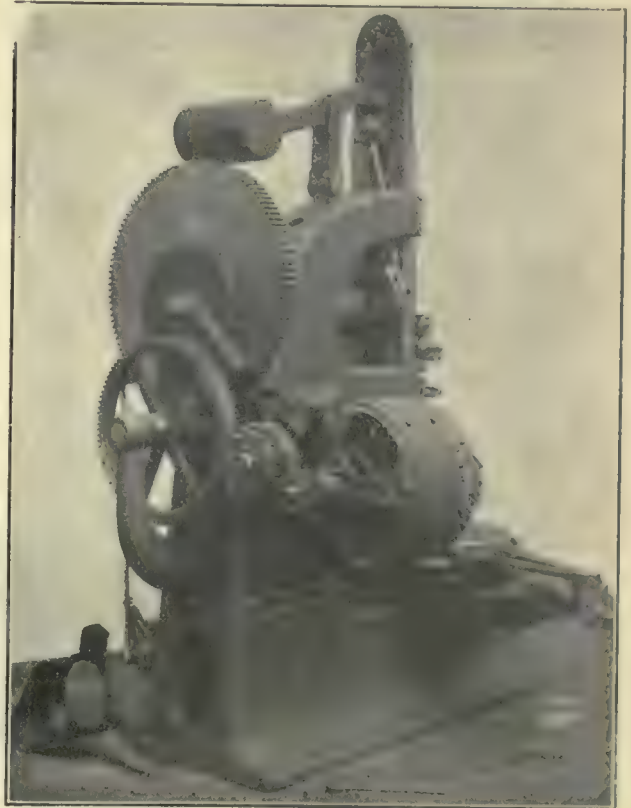

Fig. 13.—12" Slotter With Link Slotting Attachment.

for exceptionally heavy strains. It has been estimated that the cutting pressure on the two tools reaches as high as 300,000 lbs. It can therefore be imagined that the design of present day railroad shop machine tools must be in excess of everything heretofore produced to take care of wheels used in present day practice, and to stand such enormous pressures.

The face plates are 91 inches diameter, allowing wheels to be turned 86 inches diameter on the tread. The bearings are 16 ins. by 22 ins. long. The feeds vary from 16-100 of an inch per rev., to 48-100 of an inch per rev., having eight impulses per revolution. By means of clutches and change gears, working speeds are provided for all wheels from 86 ins. to 34 ins. in diameter, so that coach wheels may be turned in the same machine. The weight of the machine complete is about 102,000 lbs.

Motor-Driven Boring Mill.

The motor driven boring mill shown in Fig. 16 is a 104 in. manufactured by the London Machine Tool Co.,

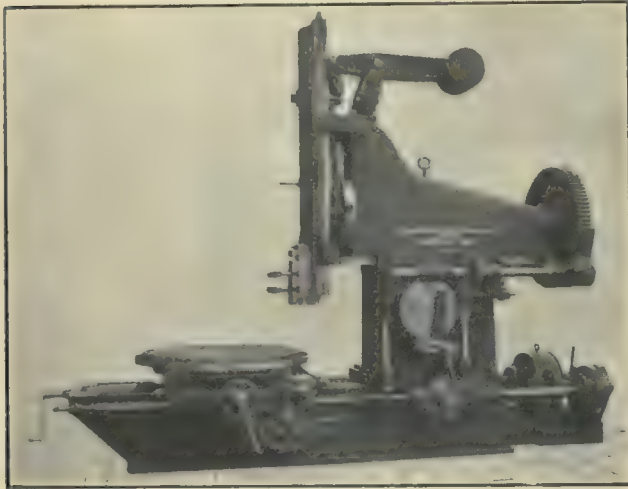

Fig. 14.—Improved Slotter Made by London Machine Tool Co., Hamilton.

Hamilton. This is operated by two D.C. motors. One is connected by gearing to the driving mechanism, and the one for raising the crossrail is located on the top of the frame.

Besides those illustrated the London Machine Tool Co., Hamilton, have redesigned their lathes, making several improvements in the attachments as well. A new radial drill, designed for using high speed steel and for heavy work has also been added to their line.

Their heavy double axle lathe is worthy of mention. It is designed to turning car, coach and locomotive axles,

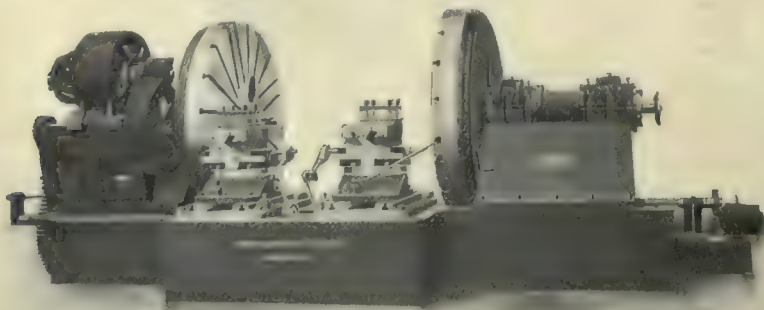

Fig. 15.—Heavy Wheel Lathe.

using high speed steels. A few of the prominent features of the machine are large bearing surfaces, powerful feed through splined rod, positive locking tool post, automatic stops to carriage feed, etc.

A Review of Improvements.

During the past few years many improvements have been made in all lines of machine tools. Fashions seem

to have entered the machine tool trade and convertible machines is one result. Immediately after the introduction of high speed steel, there was an introduction of geared feeds. It will be seen by a perusal of this article, however, that Canadian builders of machine tools as well as other companies have returned to belt drive, though the convertible machine permits the attaching of heads for either belt, motor or gear drive as desired. The latest machines as described, have belt-driven feeds.

Some of the best results removing metal have been obtained from belt driven machines so that this is not merely a whim of the manufacturers in adopting belt-driven feeds, of good width and with wide pulleys. Old patterns have been laid aside and all the machine tools have been built on new plans. A machine of five years ago is entirely out-of-date. Improvements have followed each other, new features being rapidly added. What will be developed in the next five years is hard to prophesy. The demand for machine tools is increasing and when the transcontinental railroads start equipping shops which will inevitably follow, still greater improvements must be made and new lines added to keep up with the demands for tools for railroad work.

STANDARDIZATION OF CATALOGUES.

An Engineers' Standardized Publications Association was recently formed in England, having its headquarters at Craven House, Kingsway, London, W.C. Its object is to persuade manufacturers to conform to mutually agreed standards in the size and arrangement of price lists and catalogues, and facilitate reference to these publications by scientific classification of their contents.

While the shape and size of catalogues may seem a small matter, yet anyone who has attempted the classification and arrangement of the catalogues issued by Canadian and United States, British and other manufacturers, will appreciate the great difficulty of making an orderly collection of them. The result frequently is that the catalogues are not carefully preserved as they should be, and therefore fail to carry out the full purpose of their mission. When one considers the outlay on these publications, which are often handsomely and expensively gotten

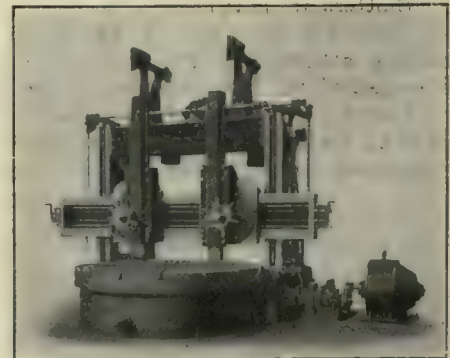

Fig. 16.—104" Boring Mill.

up, and the heavy expense of postage, the advisability of taking all possible steps to insure not merely a monetary welcome and appreciation, but a permanent place in a reference collection is self-evident. This is the age of filing cabinets, which are more or less of uniform size and all manufacturers might with profit consider the matter of standardizing their price lists and catalogues.

The Work of Overhauling Electric Railway Rolling Stock

Paper Read before the Canadian Street Railway Association, Dealing with the Various Operations in the Shops, to Keep Cars in Commission

By W. R. McCREA *

In presenting these remarks concerning the periodical overhauling of rolling stock, it is my intention to endeavor to convince those interested in the maintenance of electric railway rolling stock that periodical overhauling is absolutely necessary to obtain the maximum of efficiency and also that when this work is completed, the term, general overhaul will be amply justified.

Prior to three years ago very few of the cars on the Toronto system were overhauled with any degree of regularity. This neglect was responsible for some of the following results: Average daily cripple cars amounted to about 17 p.c. of all motor-operated rolling stock, failures in service were very common, line blockades interrupted schedules, cars out of service when required to fill schedules, inconvenience to passengers, lost mileage and revenue. This condition of affairs necessitated the introduction of a method of repairs whereby the average daily number of cripples would be reduced to a minimum. Instructions were issued by the management that all cars were to be put in first-class condition at once. This was done, but not without a very large expenditure of money; the results obtained, however, were such as to prove without the shadow of a doubt the wisdom of permitting the above-mentioned expenditure. To-day in Toronto there are comparatively speaking no motor breakdowns in service, and as a comparison I may say, that instead of 17 p.c. of the cars being crippled as before stated every 24 hours, the daily average is now 3.7 p.c.; and it must be borne in mind that every car that is repaired, whether large or small repairs, is classed in the totals from which this percentage is struck. Those not included are those cars repaired by the night and day inspectors and repair men, after the cars are housed and have completed their day's run; or, in other words, cars which have not caused any interruption to service or schedules. This is a considerable reduction you will admit, but we are endeavoring to lower this record, and those in charge of the rolling stock are of opinion that this can be done. The vastly superior service which we are now enabled to give has secured to the company a very valuable asset in the citizens' good-will.

Encourage New Ideas Among Workmen.

It is very necessary that the good work of overhauling rolling stock should be done in a most thorough and systematic way. The work should be laid out so that there will be no confusion of material, men or ideas. All the work should be done in a pre-determined manner. Gauges, measurements and tools should be supplied for the proper carrying out of the same. When a system of overhaul is finally decided upon as being the best suited to local conditions, it should become a law in the shop, and any employe departing from the standard of practice should be dealt with accordingly. The introduction of new methods or stunts or experiments should not be permitted until they are carefully considered by the proper officials. I strongly recommend that employes be encouraged to promote new ideas, and if on the presentation of them to the proper officials, they are found to possess even some small merit, every encouragement should be given the originator to perfect the same, and on the adoption of his proposal in practice he should, so far as the shop is concerned, receive all the credit due him.

Use Jigs, Patterns, etc.

In preparing the repair material in the Toronto Ry. shops, carefully kept jigs, patterns and gauges are always used in production. By this means absolute accuracy is assured, and the parts are interchangeable. The fact that the pit men or fitters have no work other than to bolt together and put to place, is a strong argument in favor of the repair material being properly produced in the company's shops or by outside manufacturers.

Toronto Railway Co.'s Methods.

I will endeavor to explain some of the methods in use in the Toronto Ry. Co.'s central shops. This system no doubt would be more readily understood by a visit to our works, which we will at all times welcome. The cars are overhauled on a mileage basis; 50,000 to 55,000 miles being the limit of distance a car travels before being brought to the shops and thoroughly overhauled. Owing to the fact that our roadbed is now in a very much better condition than it formerly was, and the cars standing up so much better, the matter of permitting cars to run 70,000 to 75,-

000 miles before overhauling is now under serious consideration.

Overhauling a Car.

I will now trace the course of overhauling a car. Owing to the fact that overhauling was first started by rotation of car numbers, it is quite easy for us in the shops to know just about the car or cars due to come in, and as accurate mileage is kept on all cars, a glance at the mileage statements is sufficient to procure the proper car for overhauling. This done, the central car dispatcher is instructed to have that car delivered to the shops ready for the following morning. The car is then placed in a section set aside for the purpose, brake and cable connections unfastened, car body raised and placed on trestles, trucks are then pulled out from under the body and shunted to truck overhaul section; here the motors are removed and sent to motor overhauling section.

The truck is completely stripped down, except side and end frame, wheel centres marked, and tramrail points used to test for truck frame being true. Journal boxes are stripped of brassed wedges and waste, and thoroughly cleansed. Wheels and journals are now replaced if necessary. The stripped material has been placed on one side of the truck, the floor on the other side is swept clean, the truck inspector inspects the old material and o.k.'s. that which is to be used again. This o.k. material is now moved to the clean space on the other side of the truck, the balance is taken to the shop storekeeper, who gives in return a new or repair part for every one sent in; this is then delivered to the truck fitters, and is placed with the balance of the o.k. material. The trucks are now built up, the journals being packed with clean, oil-soaked waste; the trucks having been thoroughly scraped and blown off with compressed air, are now given a coat of mineral quick drying black paint, and ready for the motors.

Repairing Motors.

The motors are first stripped of armatures and field coils; these with the brushholders are sent to the armature and machine departments respectively. The motor frame is next scraped inside and out, grease boxes cleaned out, bottom oiled, wells cleaned and washed with kerosene. The inside of motor frames are next painted with black in-

* Master Mechanic of Toronto Railway Co.

sulating compound, oiled canvass liners are placed around permanent pole pieces, frames are now ready for assembling. Field coils are next put to place and magnet plates bolted home, finished steel bolts and hexagon nuts with spring lockwashers being used exclusively for motor and truck work. The motor frames are now bolted together and a gauge inserted between the pole pieces to prove proper distances. The proper distance between magnets having been secured, the armature is next put to place and armature boxes bolted on. Equal clearance between armatures and magnets is next secured by use of a special gauge.

New spring felt feeder wicks are placed in bottom oil pocket of both armature and motor axle bearings, and oil receptacles filled with clean oil. Next a piece of felt is inserted in the grease hole at bottom of grease box touching the shaft, a square oil-soaked pad, half-inch in thickness, is then neatly fitted to the bottom of the box, the balance of space is then filled with hand-picked pure wool waste, the waste having previously soaked in oil 24 hours and dripped for 12 hours. Brush-holder yokes, and brushholders completely assembled, are now bolted to place. These parts do not require any alteration for the reason that they have been built up in a special jig, their correct position and alignment on the commutator being both electrically and mechanically correct.

The overhauled motor is now subjected to a running test on the floor for three hours with 40 amperes of current for the purpose of proving the condition of the bearings. While the motor is under test it is painted with a quick drying mineral black paint. The gears, pinions and gear case having been thoroughly cleaned of grease, the motor is now swung to place on the trucks and gears and pinions given an application of special compound, the two or four motors all having come through at the same time the overhaul truck and motor equipment is now ready for service.

Just as soon as car body is placed on trestles, the controller, rheostats, trolley stand and brake cylinder are removed and sent to their respective repair departments; they are at once replaced with new or overhauled material. Cable ducts on car body are opened, cleaned and repainted, renewals being made where necessary. Car body, wood and iron work repaired and painted. Overhauled trucks and motors are now run under, and body put to place, brake and cable connections made, brakes adjusted and car given a severe tryout under service conditions before being passed as o.k. by the inspector.

Armatures are first inspected for bearings and renewals made where necessary,

cast steel sleeves lined with babbit being used for bearings. Next, the entire armature is carefully cleaned, commutator turned and polished, string band carefully inspected or renewed, and sent to the testing department. Here the millivolt drop test from bar to bar is used and finally the armature is subjected to a six hundred volt ground test, armature body then shellaced and placed in the o.k. rack. Field coils are then placed in section of motor frame without magnet, and a millivolt reading taken, next a magnet attached to an air cylinder is lowered on field coil and another reading taken while the coil is under pressure. If the coil reads up to the standard and shows no variation under pressure the outside tape is repaired and the coil dipped in air drying compound.

A great reduction in motor lead trouble has been secured by boring the motor frames on the axle side and bringing the leads out as near the king bolt as possible; this, of course, refers to outside hung motors. This practically covers the entire performance of overhauling a car.

WELFARE OF EMPLOYEES.

The following is the investment and maintenance in the works of Yale & Towne Mfg. Co., Stamford, Conn.:

Investment.	
1 Heating and ventilating ...	\$74,200
2 Sanitation, drainage and water supply	49,400
3 Lighting, electric and gas ..	18,000
4 General cleanliness	0
5 Drinking water, filtration, refrigeration and distribution	6,200
6 Lavatories (included in item 2)	0
7 Locker rooms and lockers ...	57,200
8 Emergency room and equipment	1,200
9 Apparatus for removal of dust and fumes	8,000
10 Safety appliances on machinery	4,000
11 Library, reading rooms, lecture rooms and bicycle sheds	7,000
Total	\$225,200

Annual Operating Expenses.

1 Heating and ventilating ...	\$14,620
2 Sanitation, drainage and water supply	6,324
3 Lighting, electric and gas ...	3,129
4 General cleanliness	4,811
5 Drinking water	932
6 Lavatories (included in item 2)	0
7 Locker rooms and lockers ..	6,467
8 Emergency room	1,303
9 Apparatus for removal of dust and fumes	1,200

10 Safety appliances on machinery	445
11 Library, reading rooms, lecture rooms and bicycle sheds	6,206
Total	\$45,437

In round figures, says Henry R. Towne, the foregoing statements imply an investment for the above purposes of about \$100 per employe and an annual expenditure of about \$20 per employe. While admitting frankly that this expenditure, both fixed and current, is "good business," because tending to increase the efficiency of labor and the contentment of employes, it can with equal fairness be stated that, if limited strictly to business requirements, these outlays, both fixed and current, would largely be reduced, probably one-half, and that the excess over what is necessary represents, on the one hand, a volutary contribution by the employer to the welfare, comfort and health of the employe, and, on the other hand, a substitute or equivalent to the employe of a direct contribution to an insurance or pension fund, because serving indirectly a similar purpose by increasing the earning power, by prolonging the activity and thus by augmenting the potential savings of the employe.

MACHINE TOOL PRICES.

The following prices supplied to the U. S. Consul by Daimler, of Austrian Daimler Works, Wiener-Neustadt, Austria, are of interest. These tools are of good design and the shop is one of the best in Europe.

The prices paid by Daimler for various machine tools in use were as follows:

John L. Bogert, machine for turning down crank pins, No. 22 \$2,060. Prentice Bros. Co., lathe, 255 by 1,600 by 3,050 mm., \$960; vertical drills, w.p. 1d, \$111. Hendey Machine Co., lathe, 250 by 760 by 1,830 mm., \$688. Gisholt Machine Co., turret lathe, No. II. \$2,647; vertical turret lathes, No. 0, \$1,631. Landis Tool Co., grinders, No. 1½. \$926. Warner & Swasey Co., hexagonal turret lathes, No. II. \$1,760; hollow hexagon revolver lathe, \$1,535. Potter & Johnston Machine Co., automatic turret lathes, No. II, \$2,619. Cleveland Automatic Machine Co., 51 mm. automatics, 3-spindle, \$1,208; No. 1¼ automatics, 5 spindle, \$2,660. Gleason Works, gear planers, No. I, \$2,033. Becker-Brainard Milling Machine Co., vertical milling machines, No. IV, C, \$935. Cincinnati Milling Machine Co., universal milling machine, No. II, \$805. Lucas Machine-Tool Co., press for 30 atms., \$545. C. C. Bradley & Son, hammers, A No. IV., \$1,133. Yahley, pneumatic hammer, II, 1h. IV, \$1,789.

CANADIAN MACHINERY

CHORD INFORMATION.

By H. J. McCaslin.

The accompanying table of chords and angles is used by an electrical concern for spacing rator spiders, etc. I find it very handy in my shop work, and it may be found useful by some readers of Canadian Machinery.

For tool work, chord=sine × D. Angle is half of angle subtended by side at centre.

No. Sides.	Angle.	Sine.
3	60°	.8660254
4	45°	.7071067
5	36°	.5877852
6	30°	.5
7	25°	.4333837
8	22° 30'	.3826834
9	20°	.3420201
10	18°	.3090170
11	16°	.2817325
12	15°	.2598190
13	13° 50'	.2393157
14	12° 51'	.2252208
15	12°	.2079116
16	11° 15'	.1950903
17	10° 35'	.1837495
18	10°	.1736481
19	9° 28'	.1645945
20	9°	.1564344
21	8° 34'	.1490422
22	8° 10'	.1423148
23	7° 49'	.1361666
24	7° 30'	.1305262
25	7° 12'	.1253332
26	6° 55'	.1205366
27	6° 40'	.1160929
28	6° 25'	.1119644
29	6° 12'	.1081189
30	6°	.1045284
31	5° 50'	.1011683
32	5° 37'	.0980171
33	5° 27'	.0950560
34	5° 17'	.0922683
35	5° 8'	.0896392
36	5°	.0871557
37	4° 51'	.0848058
38	4° 44'	.0825793
39	4° 36'	.0804665
40	4° 30'	.0784591
41	4° 23'	.0765492
42	4° 17'	.0747301
43	4° 11'	.0729952
44	4° 5'	.0713391
45	4°	.0697565
46	3° 54'	.0682423
47	3° 49'	.0667926
48	3° 45'	.0654031
49	3° 40'	.0640702
50	3° 36'	.0627905
51	3° 31'	.0615609
52	3° 27'	.0603784
53	3° 23'	.0592405
54	3° 20'	.0581448
55	3° 16'	.0570887
56	3° 12'	.0560704
57	3° 9'	.0550877
58	3° 6'	.0541388
59	3° 3'	.0532221
60	3°	.0523360
61	2° 57'	.0514787
62	2° 54'	.0506491
63	2° 51'	.0498458
64	2° 48'	.0490676
65	2° 46'	.0483133
66	2° 43'	.0475819
67	2° 41'	.0468722
68	2° 38'	.0461834
69	2° 36'	.0455145
70	2° 34'	.0448648
71	2° 32'	.0442333
72	2° 30'	.0436194
73	2° 27'	.0430222
74	2° 25'	.0424411
75	2° 24'	.0418757
76	2° 22'	.0413249
77	2° 20'	.0407885
78	2° 18'	.0402659
79	2° 16'	.0397575
80	2° 15'	.0392598
81	2° 13'	.0387753
82	2° 11'	.0383027
83	2° 10'	.0378414
84	2° 8'	.0373911
85	2° 7'	.0369515
86	2° 5'	.0365220
87	2° 4'	.0361023
88	2° 4'	.0356923
89	2° 1'	.0352914
90	2°	.0348995
91	1° 58'	.0345160
92	1° 57'	.0341410
93	1° 56'	.0337741
94	1° 54'	.0334149
95	1° 53'	.0330633
96	1° 52'	.0327190
97	1° 51'	.0323818
98	1° 50'	.0320515

No. Sides.	Angle.	Sine.	No. Sides.	Angle.	Sine.
100	1° 49'	.545°	216	50'	.0145439
101	1° 48'		217	49'	.0144769
102	1° 46'	55.84"	218	49'	.0144104
103	1° 45'	52.94"	219	49'	.0143446
104	1° 44'	51.26"	220	49'	.0142794
105	1° 43'	50.76"	221	48'	.0142148
106	1° 42'	51.42"	222	48'	.0141508
107	1° 41'	53.20"	223	48'	.0140874
108	1° 40'	56.07"	224	48'	.0140245
109	1° 39'	4.95"	225	47'	.0139622
110	1° 38'	10.90"	226	47'	.0139004
111	1° 37'	17.83"	227	47'	.0138392
112	1° 36'	25.71"	228	47'	.0137785
113	1° 35'	34.51"	229	47'	.0137183
114	1° 34'	44.21"	230	46'	.0136587
115	1° 33'	54.78"	231	46'	.0135995
116	1° 33'	6.20"	232	46'	.0135409
117	1° 32'	18.46"	233	46'	.0134825
118	1° 31'	31.52"	234	45'	.0134252
119	1° 30'	45.38"	235	45'	.0133681
120	1° 30'		236	45'	.0133115
121	1° 29'	15.37"	237	45'	.0132553
122	1° 28'	31.47"	238	45'	.0131996
123	1° 28'	48.29"	239	45'	.0131444
124	1° 27'	5.80"	240	44'	.0130896
125	1° 26'	24"	241	44'	.0130353
126	1° 25'	42.85"	242	44'	.0129814
127	1° 24'	2.36"	243	44'	.0129280
128	1° 24'	22.50"	244	44'	.0128750
129	1° 23'	43.25"	245	44'	.0128225
130	1° 23'	4.61"	246	43'	.0127704
131	1° 22'	26.56"	247	43'	.0127187
132	1° 21'	49.09"	248	43'	.0126674
133	1° 21'	12.18"	249	43'	.0126165
134	1° 20'	35.82"	250	43'	.0125661
135	1° 20'		251	43'	.0125160
136	1° 19'	24.70"	252	42'	.0124663
137	1° 18'	49.92"	253	42'	.0124171
138	1° 18'	15.65"	254	42'	.0123682
139	1° 17'	41.87"	255	42'	.0123197
140	1° 17'	8.57"	256	42'	.0122715
141	1° 16'	35.74"	257	42'	.0122238
142	1° 16'	3.38"	258	41'	.0121764
143	1° 15'	31.46"	259	41'	.0121294
144	1° 15'		260	41'	.0120827
145	1° 14'	28.96"	261	41'	.0120364
146	1° 13'	58.35"	262	41'	.0119905
147	1° 13'	28.16"	263	41'	.0119449
148	1° 12'	58.37"	264	40'	.0118997
149	1° 12'	28.99"	265	40'	.0118548
150	1° 12'		266	40'	.0118102
151	1° 11'	31.39"	267	40'	.0117660
152	1° 11'	3.15"	268	40'	.0117221
153	1° 10'	35.29"	269	40'	.0116786
154	1° 10'	7.79"	270	40'	.0116353
155	1° 9'	40.64"	271	39'	.0115923
156	1° 9'	13.84"	272	39'	.0115497
157	1° 8'	47.38"	273	39'	.0115074
158	1° 8'	21.26"	274	39'	.0114654
159	1° 7'	55.47"	275	39'	.0114237
160	1° 7'		276	39'	.0113823
161	1° 7'	4.84"	277	38'	.0113412
162	1° 5'	40"	278	38'	.0113004
163	1° 6'	15.46"	279	38'	.0112599
164	1° 5'	51.21"	280	38'	.0112197
165	1° 5'	27.27"	281	38'	.0111798
166	1° 5'	3.61"	282	38'	.0111401
167	1° 4'	40.23"	283	38'	.0111008
168	1° 4'	17.14"	284	38'	.0110617
169	1° 3'	54.31"	285	37'	.0110227
170	1° 3'	31.76"	286	37'	.0109844
171	1° 3'	9.47"	287	37'	.0109461
172	1° 2'	47.44"	288	37'	.0109081
173	1° 2'	25.66"	289	37'	.0108704
174	1° 2'	4.13"	290	37'	.0108329
175	1° 1'	42.85"	291	37'	.0107957
176	1° 1'	21.81"	292	36'	.0107587
177	1° 1'	1.01"	293	36'	.0107220
178	1°	40.44"	294	36'	.0106855
179	1°	20.11"	295	36'	.0106493
180	1°		296	36'	.0106133
181	59'	40.11"	297	36'	.0105776
182	59'	20.43"	298	36'	.0105421
183	59'	0.98"	299	36'	.0105068
184	58'	41.73"	300	35'	.0104718
185	58'	22.70"	301	35'	.0104370
186	58'	3.87"	302	35'	.0104024
187	57'	45.24"	303	35'	.0103681
188	57'	26.30"	304	35'	.0103340
189	57'	8.57"	305	35'	.0103001
190	56'	50.52"	306	35'	.0102665
191	56'	32.67"	307	35'	.0102330
192	56'	15"	308	35'	.0101998
193	55'	57.51"	309	34'	.0101668
194	55'	40.20"	310	34'	.0101340
195	55'	23.07"	311	34'	.0101014
196	55'	6.12"	312	34'	.0100690
197	54'	49.34"	313	34'	.0100368
198	54'	32.82"	314	34'	.0100049
199	54'	16.28"	315	34'	.0099731
200	53'	43.88"	316	34'	.0099415
201	53'	27.92"	317	34'	.0099102
202	53'	12.12"	318	33'	.0098791
203	52'	55.47"	319	33'	.0098482
204	52'	38.97"	320	33'	.0098174
205	52'	25.63"	321	33'	.0097868
206	52'	10.44"	322	33'	.0097564
207	51'	55.38"	323	33'	.0097261
208	51'	40.48"	324	33'	.0096961
209	51'	25.71"	325	33'	.0096663
210	51'	11.09"	326	33'	.0096367
211	50'	56.60"	327	33'	.0096072
212	50'	42.25"	328	32'	.0095779
213	50'	28.04"	329	32'	.0095488
214	50'	13.96"	330	32'	.0095198
215	50'		331	32'	.0094911
			332	32'	.0094625

No. Sides.	Angle.	Sine.
333	32'	25.95"
334	32'	20.12"
335	32'	14.33"
336	32'	8.57"
337	32'	2.85"
338	31'	57.16"
339	31'	51.50"
340	31'	45.88"
341	31'	40.29"
342	31'	34.74"
343	31'	29.21"
344	31'	23.72"
345	31'	18.26"
346	31'	12.83"
347	31'	7.44"
348	30'	56.73"
349	30'	51.43"
350	30'	46.15"
351	30'	40.91"
352	30'	35.69"
353	30'	30.51"
354	30'	25.35"
355	30'	20.22"
356	30'	15.12"
357	30'	10.05"
358	30'	5.01"
359	29'	55.01"
360	29'	50.05"
361	29'	45.12"
362	29'	40.22"
363	29'	35.34"
364	29'	30.49"
365	29'	25.67"
366	29'	20.87"
367	29'	16.10"
368	29'	11.35"
369	29'	6.63"
370	29'	1.94"
371	28'	57.27"
372	28'	52.62"
373	28'	48"
374	28'	43.40"
375	28'	38.83"
376	28'	34.28"
377	28'	29.76"
378	28'	25.26"
379	28'	20.78"
380	28'	16.33"
381	28'	11.91"
382	28'	7.50"
383	27'	58.76"
384	27'	54.42"
385	27'	50.10"
386	27'	45.81"
387	27'	41.54"
388	27'	37.29"
389	27'	33.06"
390	27'	28.85"
391	27'	24.67"
392	27'	20.51"
393	27'	16.36"
394	27'	12.24"
395	27'	8.14"
396	27'	4.06"
397	26'	55.96"
398	26'	51.94"
399	26'	47.94"
400	26'	43.96"
401	26'	40"
402	26'	36.06"
403	26'	32.14"
404	26'	28.23"
405	26'	24.35"
406	26'	20.49"
407	26'	16.64"
408	26'	12.82"
409	26'	9.01"
410	26'	5.22"
411	26'	1.45"
412	25'	57.70"
413	25'	53.96"
414	25'	50.24"
415	25'	46.54"
416	25'	42.86"
417	25'	39.19"
418	25'	35.54"
419	25'	31.91"
420	25'	28.30"
421	25'	24.70"
422	25'	21.12"
423	25'	17.56"
424	25'	14.02"
425	25'	10.49"
426	25'	6.98"
427	25'	3.48"
428	24'	56.54"
429	24'	53.09"
430	24'	49.66"
431	24'	46.24"
432	24'	42.84"
433	24'	39.45"
434	24'	36.08"
435	24'	32.73"
436	24'	29.39"
437	24'	26.06"
438	24'	22.75"
439	24'	19.46"
440	24'	16.18"
441	24'	12.91"
442	24'	9.66"
443	24'	6.43"
444	24'	3.21"
445	24'	
446	24'	
447	24'	
448	24'	
449	24'	
450	24'	

No. Sides.	Angle.	Sine.
451	23'	56.81"
452	23'	53.63"
453	23'	50.46"
454	23'	47.31"
455	23'	44.17"
456	23'	41.05"
457	23'	37.94"
458	23'	34.84"
459	23'	31.76"
460	23'	28.69"
461	23'	25.64"
462	23'	22.60"
463	23'	19.57"
464	23'	16.55"
465	23'	13.55"
466	23'	10.56"
467	23'	7.58"
468	23'	4.61"
469	22'	1.66"
470	22'	58.72"
471	22'	55.79"
472	22'	52.88"
473	22'	49.98"
474	22'	47.09"
475	22'	44.21"
476	22'	41.34"
477	22'	38.49"
478	22'	35.65"
479	22'	32.82"
480	22'	30"
481	22'	27.20"
482	22'	24.40"
483	22'	21.61"
484	22'	18.84"
485	22'	16.08"
486	22'	13.33"
487	22'	10.59"
488	22'	7.87"
489	22'	5.16"
490	22'	2.45"
491	21'	59.75"
492	21'	57.07"
493	21'	54.40"
494	21'	51.74"
495	21'	49.09"
496	21'	46.45"
497	21'	43.82"
498	21'	41.20"
499	21'	38.59"
500	21'	36"

BOOK REVIEWS.

METAL SPINNING—By Fred. D. Crawshaw, M. E., Assistant Dean, College of Engineering, University of Illinois, Popular Mechanics Co., Chicago, Ill. Cloth, 5x7 ins.; 74 pages, illustrations. Price 25 cents.

This is the only book on the subject, Metal Spinning, a very old art handed down from generation to generation without the medium of the printed page. It is a working manual of explicit instructions which is concise, yet complete and adapted to the use of manual training and industrial schools, as well as those who desire to spin metal as an art recreation or to follow this work as a trade.

EFFICIENCY AS A BASIS FOR OPERATION AND WAGES—By Harrington Emerson. Published by the Engineering Magazine, New York, 171 pages, cloth bound, 5 x 7 1/2 ins. Price \$2.

The book is a result of a series of articles by Mr. Emerson published in the Engineering Magazine. These are now issued in book form. In the early chapters he points out typical inefficiencies in production and discusses the strength and weakness of existing systems of organization. Five general chapters covering the above ground are followed by a chapter on "The Realization of Standards in Practice." Some details are given of the method employed in standardizing as to time and cost, the tasks in a shop employing 2,000 men, each doing an average of four different jobs each day, a diagram is made illustrating graphically the effect on costs and profits of an increased output due to staff stimulus and bonus to the line. In chapter VII on "The Modern Theory of Cost Accounting" the author differentiates cost accounting from the work of the efficiency engineer, which is to establish standards, ascertain current efficiency and provide remedies which will bring low efficiency up to 100 per cent. Emphasis is put on the co-operation of the comptroller and the efficiency engineer. In chapter VIII "The Location and Elimination of Wastes" are discussed, and some examples are given of wide variations in costs in different establishments engaged in the same line of work. An efficiency system in operation is described

in chapter IX and then in order "Standard Times and Bonuses" and "What the Efficiency System May Accomplish."

A STUDY OF THE OPEN HEARTH—Published by the Harbison-Walker Refractories Company, Pittsburgh, Pa. 91 pages, 5 x 8 ins. Flexible leather binding. For sale by R. S. Davis & Co., Pittsburgh. Price \$1.

This book is a result of a study of the open hearth steel furnaces for the use of the operating department and is unique as no author's name is given nor does the name of the company appear except on the cover. Neither are there any advertisements. The reason for the book appearing in its present form was because of the interest shown in the data gathered together by a number of open hearth superintendents. The book presents in a concise form the principles involved in the manufacture of open hearth steel, and it should be of interest to iron and steel men generally. Detailed descriptions of the construction and operation of these furnaces are given in simple language that can be readily understood by one familiar with no more than the most elementary principles of chemistry and metallurgy.

Practical instructions are given for building the hearths and bottoms, front and back walls, bulk heads, ports, regenerators, etc., while the various materials for the bottoms (acid, neutral and basic), are discussed at length. One chapter is devoted to fuels, including natural, artificial and producer gas and oil. Simple methods of estimating charges for both basic and acid open-hearth furnaces are given, and these should prove of the utmost value to both shop superintendents and melters. The elimination of impurities during and after melting is explained in detail, and also recarburization, melting, method of charging, removal of slag, etc. The special processes such as the Talbot, Monell, Bertrand-Thiel and the duplex are briefly described.

MECHANICAL WORLD POCKET BOOK—Published by Emmott & Co., 65 King St., Manchester, Eng. 390 pages, 4 x 6 ins., illustrated. Price 6d or 12 cents. Postpaid 16 cents.

In this, the twenty-third annual issue, numerous improvements have been effected and a considerable amount of new matter introduced. The section on Gas Engines has been thoroughly revised by W. A. Tookey, and the same author has supplied an entirely new section on Oil Engines, including notes on Crude Oil Engines. Some condensed notes on the Design of Centrifugal Pumps have been contributed by B. M. Woodhouse, and a new section on Ball Bearings has been included. Among other additions are the following:—Dimensions of Marine Boilers; Tapers and Angles; Change Wheels for Cutting Metric Pitches; Hobs for Cutting Involute Gears; Dimensions of Ring-oiled Bearings; Notes on Double Helical Gears, Bevel, Spiral, and Worm Gears; Emery Wheel Speeds; etc. Various other tables and data have been introduced and the work revised generally. The publishers are to be commended upon their continued enterprise.

BRITISH TRADE IN CANADA—By Herbert J. Rodger, published by "Canada," Newspaper Co., 34 Norfolk St., Strand, London, Eng. 72 pages, 4 1/2 x 6 ins., illustrated. Price, one shilling.

The book is a result of a business trip through Canada in 1908, by Mr. Rodger and is a reprint of thirteen articles contributed to Canada. His report covers every line of British goods and manufactures for which there is a market in Canada. Among the subjects treated are Aluminium Goods, Machinery, Electrical Goods, Metals and Manufactures of Metals, Metals in Raw State, Bolts and Nuts, Packing, etc. The subjects include also railway and shipping facilities, catalogues, cost of traveling, advertising, etc. The work should be of great practical value to the British manufacturer looking to the Canadian market to extend the sale of his output.

Some Pertinent Paragraphs Selected From Our Exchanges

Many Useful Ideas Given in a Paragraph—Abstracts of Important Subjects Being Treated in the Technical Publications.

System in the Twentieth Century.

The old way for a workman to get the big traveling crane, by going out in the runway, waving his arms like a windmill and yelling until he was hoarse at the sleepy crane operator two or three hundred feet away, has all been done away with, and now the workman presses one of the buttons set at convenient distances along the shop runway, a red light is flashed in plain view of the crane man and, unless already employed, he at once runs his crane to where it is needed. Then, too, there is a messenger system in use that obviates the necessity of a machinist leaving his work to get a new jig or tool, as he has only to press a button close to his machine and an annunciator near the tool room indicates to a waiting messenger boy where he is wanted, as all machines are numbered; he then goes at once and finds out what is wanted, gets it for the man and returns to his place ready for another call.—Machinery.

Making a Skilled Mechanic.

The best way to obtain skilled labor is to make it.

This is the conclusion that the C.P.R. has reached after trying various methods and watching how the corporations get their supply. It has furthermore determined that the making of it shall be thorough.

It is said that although some railways and industrial firms which have entered upon elaborate schemes for the training of apprentices, the educational schemes, with one or two exceptions, lack continuity. They leave off where they practically should commence, and the apprentice or employe is turned out after a partial training and left to his own resources.

The question of the "Making of a Skilled Mechanic" is discussed in an article in Canadian Machinery, by Mr. F. C. D. Wilkes, B.Sc., who takes as his object lesson the scheme of the C. P. R. for obtaining skilled labor.—Montreal Herald.

The Boss's Shadow.

A business demands the entire time and attention of the proprietor or manager. A word, a friendly nod goes a long way. An old mechanic once said, "The boss's shadow is worth \$5 every time it falls across the job.—Men's Wear.

Tool Rooms and the Care of Tools.

The fact has grown upon us that those shops where a thorough card sys-

tem is in vogue in regard to tools and their uses seem to get the work done with less friction and less loss of time than is the case in those shops where no card system exists. The card system that we refer to implies a systematic method of numbering the pieces of work that may pass through the hands of the workmen. The number of operations in their order, the number of tools required and their specific markings, are set down, to which in a general way the average time taken in the operations may be added. The mere matter of storing the tools must necessarily remain an open question which will readily be solved by the intelligent foreman and superintendent to suit the requirements of the situation—Railway and Locomotive Engineering.

To Furnish Apprentices.

"Canadian Machinery" devotes two pages to Hamilton Technical School with one page of illustrations. It regards the school as likely to furnish apprentices for many of Hamilton's great manufacturing industries.—Hamilton Times.

The Designer and Shop Costs.

Inefficiency in the operation of machines, while not always readily discernible, can be detected by experimenting with different methods, without adding much to the cost of production, even temporarily. Losses arising from badly arranged buildings and machines can be detected by close observation of daily operations, and the cost of providing better facilities, as well as the saving to be expected by their use, can be ascertained within narrow limits.—Southern Machinery.

Get Next and Keep Near Your Employes.

Are you an employer of men? Get near them—keep next. No man who cannot get next and then keep next can control men successfully to the end of eternal welfare and the permanent success of an industry.

"I keep my employes in their place during the work day. After hours they are my friends," said a wise old fellow who always had an open mind for a new or better idea. It keeps up a mutual interest that makes for harmony and the absence of friction. We may be wrong, but it is our idea that the absence of friction is a big factor in a profitable business.

Get next and don't lose your grip.—American Shoemaking.

Watch the Iron Prices.

The foundryman who has an absolute control over his mixtures, following up each detail and studying the market carefully, is able to work in a considerable tonnage of off grades of iron, including malleable, Bessemer and various other grades which at times can be picked up at a special price. As the price of foundry iron has a tendency to increase, the tonnage of this class of iron utilized by foundrymen generally increases. This in turn serves to prevent the price of foundry iron from soaring unduly high.—Castings.

The Devil of Debt.

The devil of debt seems to be on the heels of almost everybody. The clerk, he's in debt. The bookkeeper's in debt. Ditto the typewriter. Same with the porter and drayman. As to the superintendent, he can't remember when he wasn't. The office boy would be in debt if anybody would trust him. And all of them complaining and acknowledging the miserableness of their condition.

Debt is a mortgage on your salary.

Debt is a monument to a young man's weakness, a grown man's folly and an old man's failure in the university of life.

Debt is discounting to-morrow's liberty for to-day's good time.

Debt is a quitclaim to your wife's confidence, your children's ambitions and your own self respect.

Debt is a guaranteed insurance policy against happiness.

"Then what are we going to do?" say a chorus of young fellows and business men and aspiring women and laborers and clerks and managers and street car conductors and hundreds more.

Do without!

It will take some backbone. It will take some genuine courage.

But you'll be able to hold your head up—and that's more than you can do now, and you know it. You won't have palpitation of the heart when the postman blows his whistle, and you won't tremble every time the boss asks you to come into the front office. Neither will you be ashamed to have your stenographer open your mail.

Because you'll be working to-day for to-morrow's satisfaction, and not to make good on account of yesterday's extravagance.—Pittsburg Press.

MACHINE SHOP METHODS ^A_N^D DEVICES

Unique Ways of Doing Things in the Machine Shop. Readers' Opinions Concerning Shop Practice. Data for Machinists. Contributions paid for.

MILLING ON A PLANER.

By K. Campbell.

Mr. Stevens of the Stevens Co., Galt, Ont., has in use in the machine department a milling machine which he constructed under his supervision. Since then several have been made for other companies, the original one being shown in the illustrations herewith.

Fig. 1 shows the machine at work and Fig. 2 shows the driving mechanism. A piece of work is on the planer, and in the illustrations the miller is shown at work, a large casting being on the planer. The belt shown in Fig. 2 connects with an overhead, and power

the superintendent of the machine department. The holder A is made of machinery steel with the end slotted

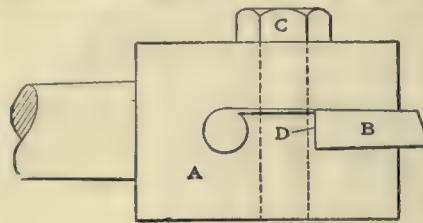

An End Mill.

for the cutter B, which is clamped with an ordinary $\frac{1}{8}$ -inch cap screw C. The cutters are made from high speed steel

By M. E. D.

By K. Campbell.

A simple arrangement for holding drills has resulted in a saving in drill accounts in the shops of the Stevens Co., Galt. An iron plate about 1-inch thick is used, it being drilled to hold various size drills. Formerly long drills used to be taken and used for all work but with the arrangement illustrated a workman finds it just as handy to take short drills and use them for work where short ones can be used.

The drill plate contains two holes for each of the larger size drills and four holes for the smaller sizes. The holes

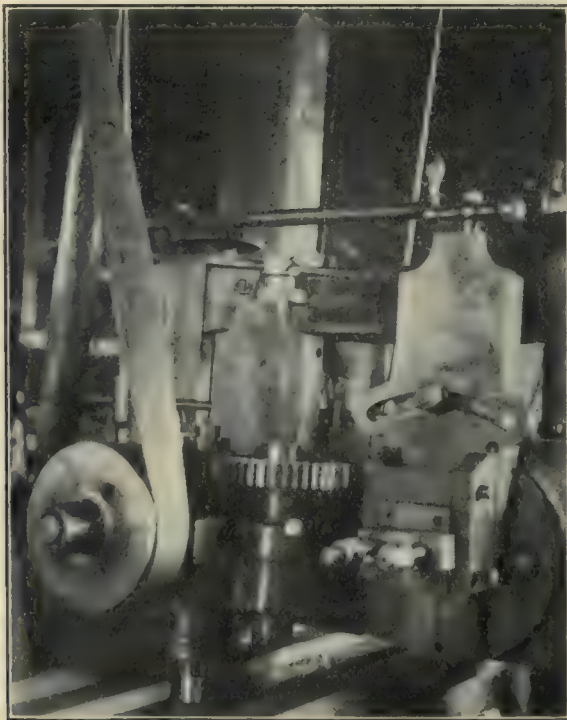

Fig. 1.—Milling Machine Milling on a Planer.

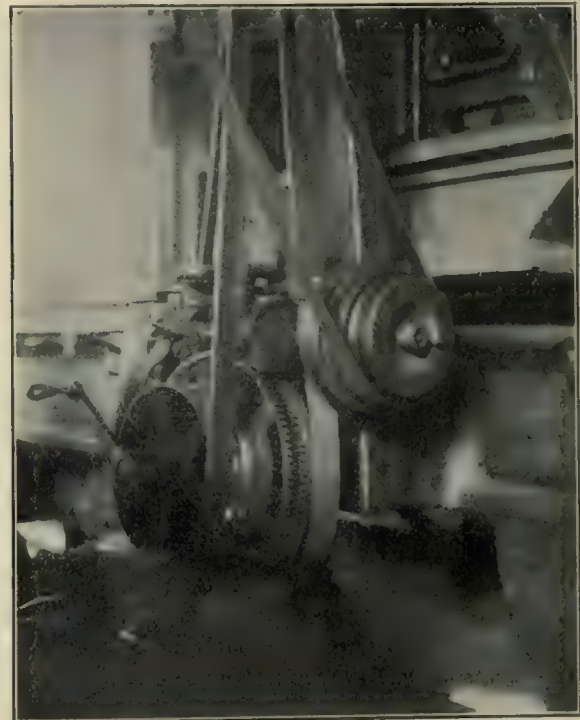

Fig. 2.—Driving Mechanism of Milling Machine and Planer.

is taken to the miller by the belt shown in Fig. 1. The machine is fastened to the planer head and is under full control of the planer operator. It has been found that with the miller, work can be accomplished in a short time that formerly took hours to do.

AN END MILL.

By K. Campbell.

The accompanying cut is an end mill used in the works of Smart-Turner Co., Hamilton, manufacturers of pumps, cranes, etc., and designed by

blades of cutting-off tools, the top or widest part D being used as the back when in the holder. These are used on steel and brass with a cutting face up to $2\frac{1}{4}$ inches.

JIG TO HOLD MITRE GEARS.

Under this heading it was stated that F. A. Rodgers devised the device shown on page 43 of the December issue of Canadian Machinery by means of which he turned out "25 in nine minutes." This should have read "25 in nine hours," which meant a great saving over the old method.

are drilled the exact size of the drill and when the machine hand is finished

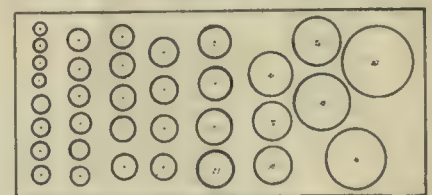

Plate for Drills—Plate May be Drilled to Suit Drills Used.

with a drill he returns it to the plate. The plate is handily situated on a small stand beside the drill.

AUTOMATIC RELIEVING FRICTION CLUTCH.

By C. J. Fensom.*

The friction clutch shown in the illustration was designed to drive a piece of heavy, slow running machinery which was liable to become "jammed" at any moment. The arrangement of the machine would not permit of the use of a belt; and it was feared that the ordinary form of clutch, if made powerful enough to drive when the friction surfaces were smooth and oily and when the adjustment was slack, would be of little use as a relieving coupling at times when the adjustment was slack and the surfaces rough through disuse.

The design of the clutch shown is such that it can only transmit power up to a definite pre-arranged maximum

pull. Should the torque transmitted tend to exceed the capacity of the springs, the springs will yield, thus allowing the end friction plate "E" to turn slightly in relation to the driving casing "F." This motion allows the end friction plate (B) to screw back until the pressure between the friction surfaces of clutch is reduced to such an amount as to just allow a driving force to be exerted corresponding to the strength of the driving springs.

This clutch can be made "reversible." It could be used, without hand operating mechanism, as a relieving coupling in cases where the ordinary form of clutch would become in-operative through periods of disuse and consequent "freezing together" of friction surfaces.

paint as the application of relatively hard coats over relatively soft coats. This is an observation which should be kept in mind not only in the painting of metals, but in all painting. That the priming coat should have the power to adhere tenaciously to the surface is self-evident.

The pigment constituents of a protective paint should be inhibitive of corrosion. This means that it should tend to give passivity to the particles of the iron itself—should by its nature tend to prevent that activity of molecules which we have described as galvanic and which causes corrosion.

A protective paint should be a non-conductor of electricity. The corrosion of iron and steel being the result of a galvanic action, it is necessary not only

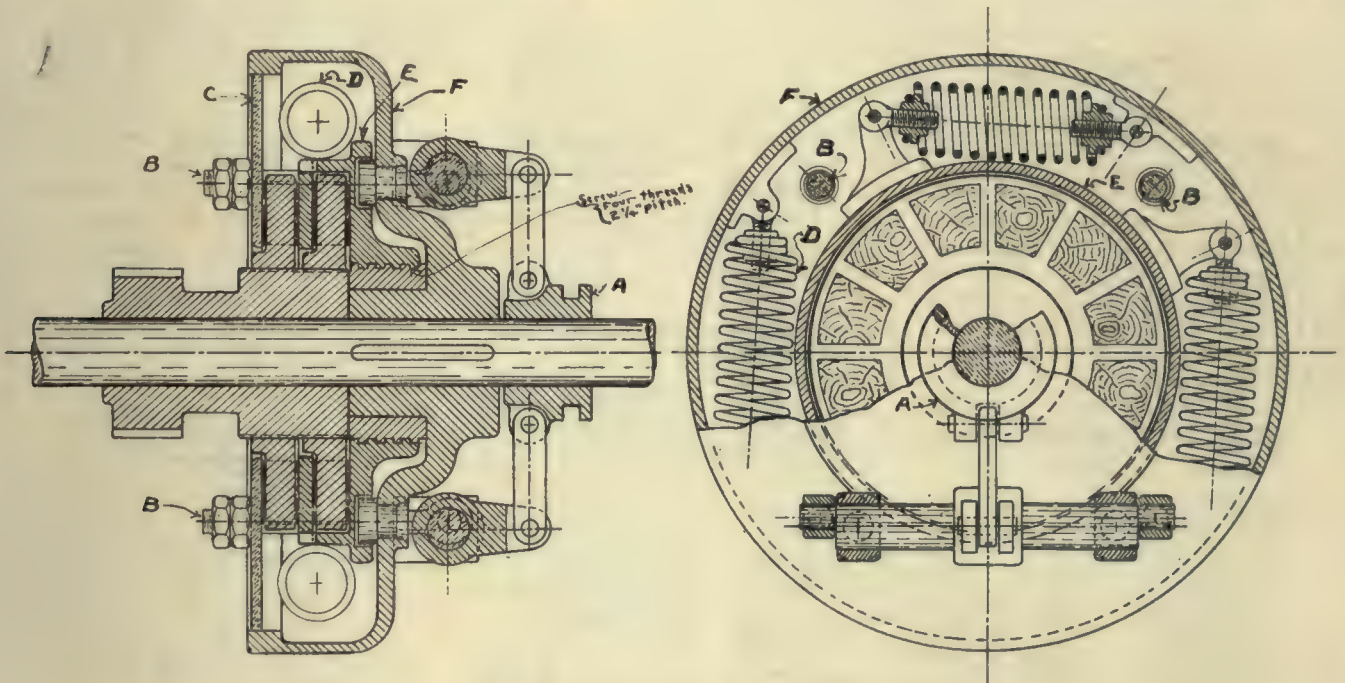

Automatic Relieving Friction Clutch.

torque, regardless of the condition of the friction surfaces. This means that the driving motor, or the machinery driven, cannot be subjected to an undue strain when the machinery is started against a heavy inertia load, or should a "jam" occur.

The clutch is operated by hand in the ordinary way. A motion of the sleeve "A" causes the four compressing bolts "B" to act on the end friction disc "C," thus relieving or pressing together the four pairs of friction surfaces.

The principle of the special regulating feature of the clutch is as follows: When the clutch is in action the torque is transmitted through the medium of the heavy driving springs "D," which are set to yield at a certain definite

PAINT FOR METAL SURFACES.

By O. C. Harn.

Regarding preservative coatings for iron and steel, we find it necessary to point out that a paint which may be a good paint for the under coats may prove to be an undesirable paint for the outer or finishing coats, and vice versa. We will call the paint which is to go next to the metal the "protective paint," and the paint which comes outside the "finishing paint." The finishing paint should be, in reality, a "protective paint" also, but, for clearness in discussion, it is necessary *we should make a distinction.

The protective paint should measure up to the following:

It should form a hard, adherent foundation for subsequent coats. There is nothing else which tends so much to the cracking, checking and alligating of

to put on a paint which will be inhibitive—that is, keep out those influences which will set up the galvanic action in the iron itself—but it is supremely necessary also to bar the way to stray electric currents from the outside. In these days, when electrically charged wires run everywhere, under the streets, overhead and through all buildings, the leakage of electric currents is an every day problem. The real solution of the problem would seem to be to confine these electric currents where they belong instead of allowing them to run riot among neighboring property. Motives of economy itself will doubtless some day lead the owners of the runaway electricity to correct this evil themselves, but until that day arrives we must do our best to protect our property against currents which are running amuck.

* Consulting Engineer, Toronto.

DEVICE FOR DRAWING OVOIDS.

By J. O. Brouillet.

The instrument illustrated herewith can readily be made by any handy man, and will enable him to draw ellipses of various sizes and ovoids as well. It consists of a sheet-metal piece A, in

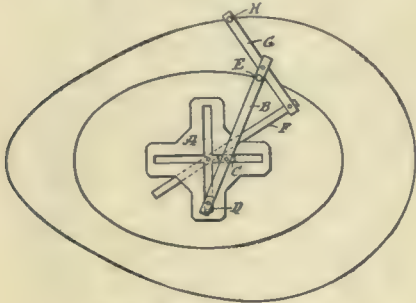

Device for Drawing Ovoids.

which two slots are cut crossing each other at right angles. A lever B is provided with two blocks C and D, adapted respectively to slide in the slots. A lever F, which is fulcrumed at the centre of the plate A, is connected by means of a lever G with the end of the lever B. A pencil may be fitted through a hole in the lever B, and as this is revolved around the plate A, it will trace an oval or elliptical line. At the same time a pencil in the lever G will trace an ovoid, as indicated in the drawing.—Scientific American.

TOOL POST PLATE.

By Robt. Buchanan.

The accompanying sketch shows a tool-post plate to be used when boring

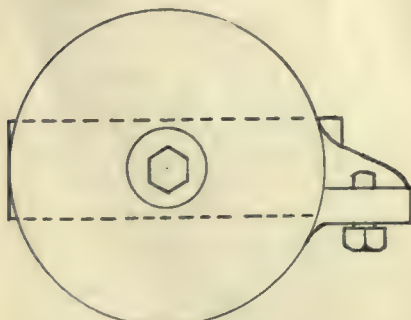
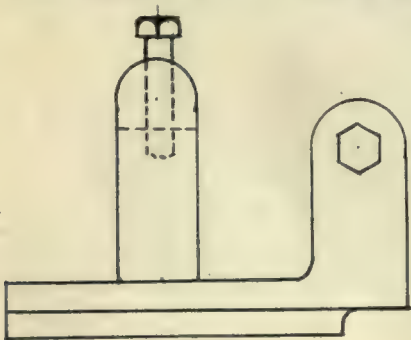

Tool Post Plate.

on the lathe to prevent the tool from swinging round. It may be made to use the wedge or will give better ser-

vice if made flat and of the right height to carry tools or tool holder.

The cleats on the bottom are shaped to fit the rest, while the set screw on the lug at the back is adjusted to the tool after it is set.

AN ADJUSTABLE INSIDE FACING TOOL FOR THE DRILL PRESS

By Charles Eisler.

The cut shows in section a facing tool for inside work on the drill press. The operation on this work was always made in a lathe where it required a

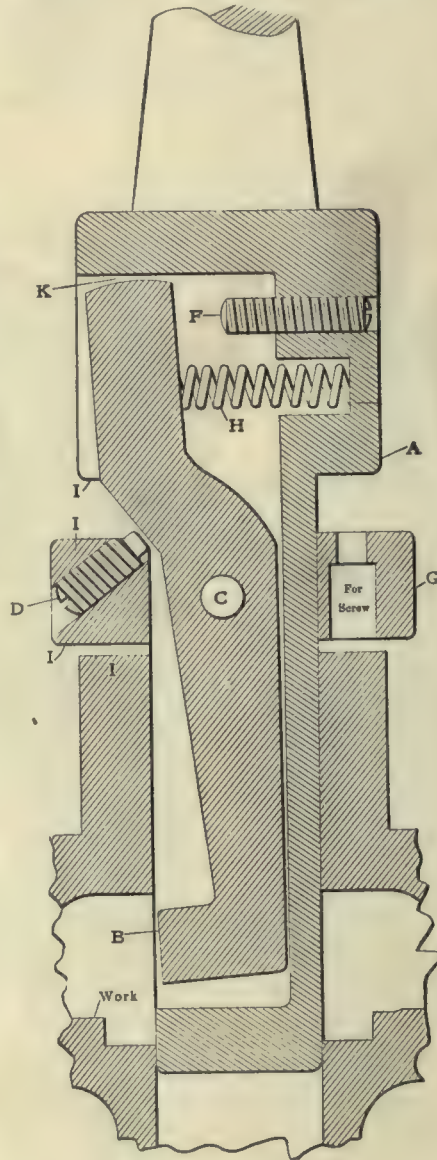

An Inside Facing Tool.

skilled man. A man with very little skill can do the same job with greater output now.

A is the body of the tool holder (a round piece of tool steel) in which a slot was made for the facing tool B. C is the pivot pin. D is an adjusting screw. After the tool B is ground it can be adjusted to the required size. F is also adjustable to prevent the tool going too deep. G is a sliding stop

collar on A (screws not shown). H is the spring which holds the tool B within the holder body A and strips the collar G down, after the work is done. When the faces I I I I are together the work is done.

The tool B was also fitted to bear on K to prevent the quick wearing on the pin C. It will be noticed that the tool holder on the lower end is not cut through so as to make it more solid. The tool was used on brass, but there is no reason why it should not work on other materials.—American Machinist.

SHOP DOOR CLOSING DEVICE.

The heating of factories, machine-shops, roundhouses and other buildings having large doors is seriously retarded by the leakage of volumes of cold air in over the doors at the top. The ordinary large sliding or swinging door almost invariably bulges at the top, making a crack of considerable width through which the cold air blows in greater or less volume according to the exposure and the velocity of the gale.

During the past few years the heating of large shops and roundhouses has

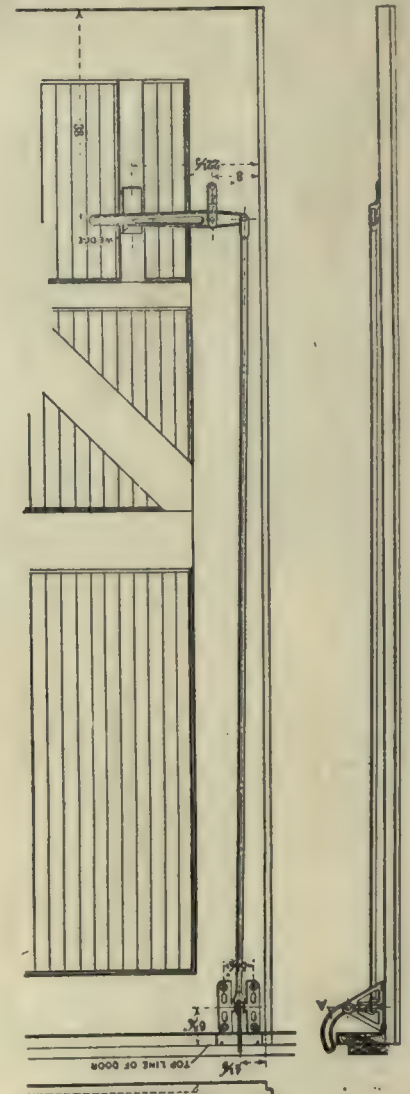

Shop Door Closing Device.

received a great deal of attention, and no modern structure is considered complete without adequate means of heating. The old idea that the men should keep warm by hustling has been generally discarded, and now every up-to-date factory manager realizes the importance of providing as nearly as possible a uniform, comfortable temperature in all workrooms. The cost of heating large buildings in northern latitudes is a heavy item, and practical means that will shut out the cold air where it should not enter, merit attention.

Realizing the serious loss that results from bulging doors in railway shops as well as in other works having large doors, through the lack of close fit at the top, J. C. Hassett, technical instructor of apprentices of the Erie Railroad, Meadville, Pa., has devised the shop-door closing device, illustrated herewith, in which the action of the device and the details of the component parts are shown.

The arrangement provides means by which the door is clamped and forced solidly against the jamb at the top by means of the curved piece A, which is worked by a connection and lever conveniently located on the door. The connecting rod may be of any length required to suit the door height.—Machinery.

HANDY BENCH TOOL.

By F. B. Kennedy.

The accompanying sketch shows a very handy tool suited for all mechanics who find it necessary to snip small pieces of cottars, rivets, etc. It will cut with a clean fracture up to 5-16 or $\frac{3}{8}$ inch soft steel or brass wire.

The plunger should be made a good fit for the barrel and cupped out as shown, but not too sharp an edge. The

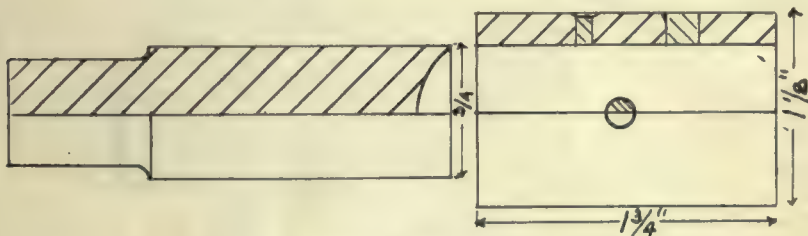

Hardy Bench Tool.

holes may be bored of course, to suit the convenience of the worker and good steel should be used for the whole tool.

A CUTTING-OFF TOOL.

By A. Strong.

The accompanying sketches illustrate a couple of tools we have found to be very handy. Perhaps they are not new, but I have not seen them before.

Figs. 1, 2 and 3 illustrate a cutting-off tool for rapidly cutting to the same length rods and pins. The tool A is reciprocated by the lever B working on the fulcrum C. D is a stop for the lever B in the back position. The stock is in-

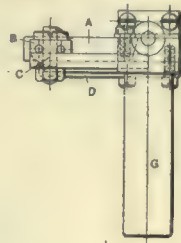

FIG. 1.

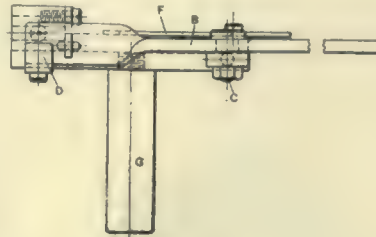
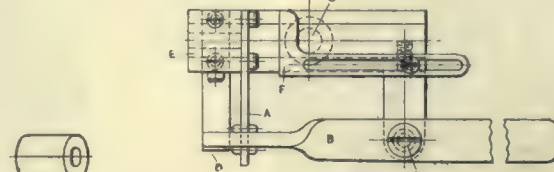

FIG. 2.



CUTTING-OFF TOOL.—FIG. 3.



FIG. 6.



FIG. 4.



FIG. 5.

serted through a loose bushing E, which may be changed for different sizes. The adjustable gauge F fixes the length. We used the tool in a small single gear hollow mandrel lathe, and the shank G was held in the toolpost provided for the hand rest. The wire was drawn forward each time against the stop F, after releasing the chuck. The chuck was then tightened and the parting off rapidly done by means of the tool and lever described.

Fig. 4 shows a simple centering tool used in conjunction with the above. It was made to drill exactly central, and all to the same depth, some thousands of small steel dies. The stock was held in the chuck of the lathe, and the tool was held by the shank S in a lathe car-

DRAWING OF V-THREADS.

By Joseph Weaner.

I found the drawing of V-threads to be very trying until I thought of the following scheme which makes this work much easier. The idea is as follows: File

a number of 60-degree notches in the inner edge of the triangle, as shown in the illustration, for different thread pitches. Make the top width x equal to 1 divided by the number of threads per

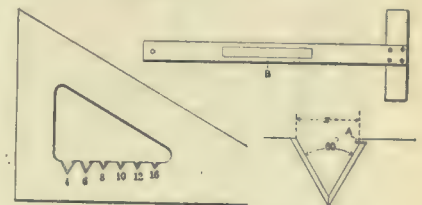

Drawing V Threads.

inch, and leave a small point A to stop the pencil. To use the triangle, place the pencil against the left side of the notch and run it down that side and up the other to the stop; then move the triangle to the right until the pencil is again against the left side. By repeating this operation as many times as is required, a uniform thread can be rapidly drawn. Another suggestion for draftsmen is to have a 12-inch scale fastened to the T-square as shown at B. This is also a time-saver, as the scale is in a position where it is always ready for use.—Machinery.

rier, and was brought up by means of the back centre. The aperture T, of course, exactly fitted the stock. After drilling they were parted off with the tool described above.

Figs. 5 and 6 show the articles we had to produce in some thousands, and in the rapid production of which these tools assisted not a little.—Mechanical World.

According to a writer in the Scientific American, a very handy tool can be made from an old pair of scissors or shears by cutting one blade with a set of saw teeth inclined toward the handle. These teeth hold the material fast, and prevent it slipping toward the point of the shears. Rubber sheeting, strips, and all kinds of soft packing can be easily cut with square or inclined ends.

DEVELOPMENTS IN MACHINERY

New Machinery for Machine Shop, Foundry, Pattern Shop, Planing Mill; New Engines, Boilers, Electrical Machinery, Transmission Devices.

SHELDON'S IMPROVED REVERSIBLE EXHAUSTER.

Herewith are illustrated Sheldon's new reversible type medium blowers and exhausters. These fans are reversi-

powdered coal into rotary kilns or other furnaces, ventilating toilet rooms in public buildings, etc. They are practically noiseless, even at very high speeds.

shown in Fig. 1. Fig. 2 shows the spindle which, through the reverse tumbler, drives the stud gear shaft M. On this is bevel gear A that meshes with pinion B driving shaft R and worm C.



Fig. 1.—Medium Exhauster (Reversible Type.)

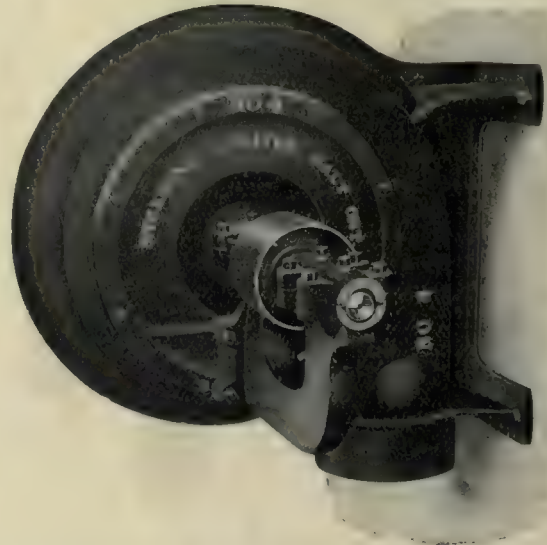

Fig. 2.—Reversible Exhauster, Bolted to Wall or Post, Discharging Downward.

ble and interchangeable and can be bolted to the floor, wall, post or ceiling. The bolt holes around the side openings are drilled to a template equal distances apart and are alike on both sides, therefore the arm and circular plate supporting the bearings can be removed and attached to the opposite side of the fan, the inlet side plate being interchangeable, thus reversing the hand of the fan.

The circular side plates referred to are larger in diameter than the fan wheel so that the wheel can be removed without taking the whole fan to pieces. The bearings on these fans are self-oiling and self-adjusting and are of the ring oiling type, capable of continued operation without undue attention.

Every wheel is carefully and accurately balanced before mounting and all fans are tested before leaving the works. The sizes of the wheels on these fans are practically the same as on our standard type medium exhausters and the fans are specially adapted for handling gritty dust, such as comes from emery wheels, tumbling barrels, rattlers, etc., which quickly cuts into and destroys sheet steel.

They are specially adapted for the removal of smoke from forge fires, steam from cooking vats or kettles in dye works, breweries, packing houses or other factories, blowing coal dust or

These exhausters are manufactured by Sheldons, Galt, Ont.

CINCINNATI 16-INCH LATHE.

The Cincinnati lathe is furnished with an all geared device having an unlimited range in addition to the quick change gear lathe for cutting screws

These are supported by swinging bracket G pivoted about shaft M. To shaft S, in the gear box, is splined a triple-worm wheel D E F, that pass constantly through oil held in a reservoir. Any one of these wheels may be shifted into position under worm C by fork T, operated on outside of box. The rate of



Fig. 3.—A Reversible Exhauster, Bolted to the Ceiling and Discharging Horizontally.

speed is changed at once by pulling out bolt P then raising arm G and shifting to the worm wheel giving the desired feed. When engaging sliding gear H I

ing the use of the change gears also furnished.

Twenty-two additional changes ranging from 5 to 64 per inch may be ob-

tained to suit special cases by sliding gear W on lead screw in mesh with gear J, on feed rod, which is driven direct from spindle. Lead screw is operated only when required for actual threading. Lock bolt U and arm G are so placed that the former prevents gear W being thrown into mesh with J until G is raised when it is impossible to engage worm wheels.

Both Figs. 1 and 3 are furnished with apron of box type construction, chasing dial, automatic stop, plain or compound rest, centre rest, follow rest, large and small face plates, necessary wrenches, self-oiling friction counter-shaft, etc., either five step or extra wide three step cone with double back gears, and the metric system if desired. Taper attachment may be added to equipment when wanted. Drawn-in attachment, oil pan, turret on carriage, can be furnished, and a lathe with six

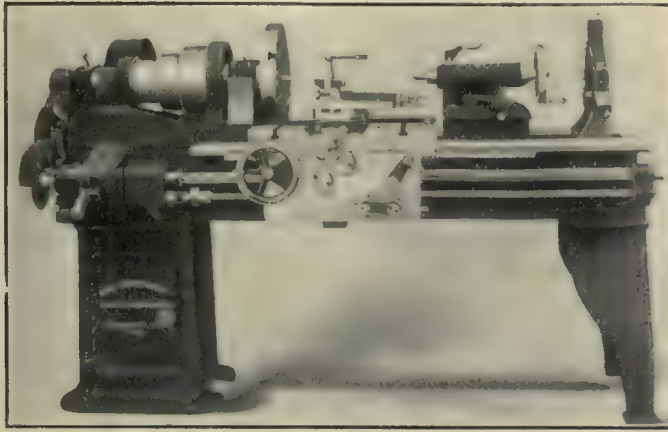

Fig. 1.—Cincinnati Lathe With Three-Step Cone.

with either J or K, on feed rod, permits six changes instantly varying from 16 to 100 turns per inch, a range of

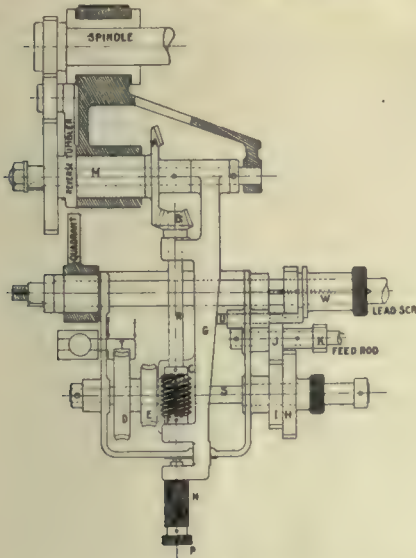
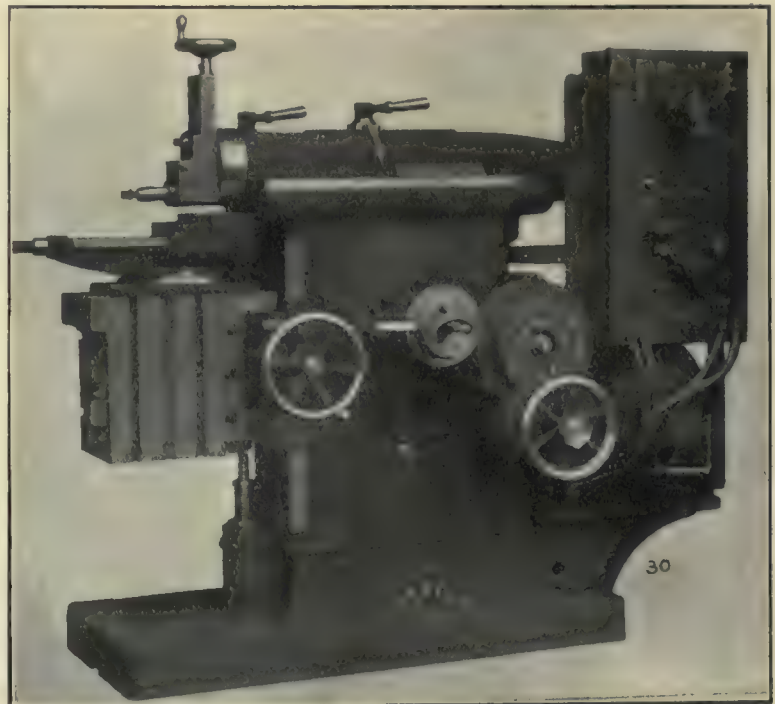

Fig. 2.—Diagram of Positive Feed.



Improved 16" Steptoe Shaper.

feeds enough on any 16-inch lathe for general manufacturing, without requir-

positive geared feeds by merely shifting a lever using the regular or any special change gears for screw cutting.

These lathes are manufactured by the Cincinnati Lathe & Tool Co., Cincinnati.

JOHN STEPTOE 16-INCH SHAPER.

The principal feature connected with the drive is in the fact that the motor stand is set on the base of the machine, thus avoiding any vibration when the motor is running, and at the same time it is as close to the column of the machine as it is possible to get it. It takes up no more room than is actually required for the return stroke of the ram. This was necessary on account of the

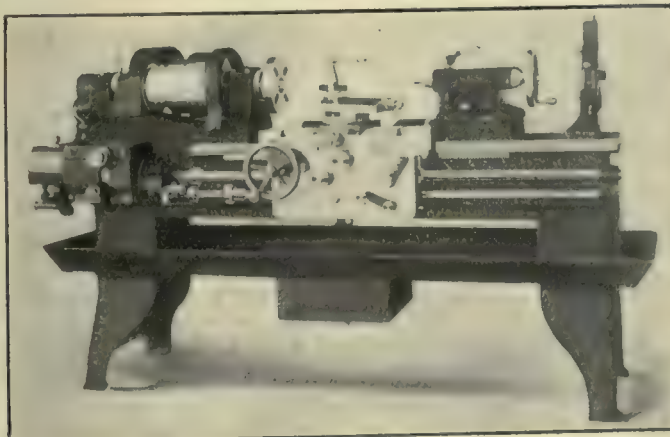

Fig. 3.—Cincinnati Lathe With Instantaneous Change Gear.

fact that the machine was built for the U. S. Battleship, "Delaware," and as the space was limited, it became necessary to take only as small a space as possible. The controller was placed on the top of the motor so that the operator would not be compelled to leave his position to change the speed of the machine. The motor was manufactured by the General Electric Co., and has a speed variation of 2:1.

The new feature on this machine is the self-adjusting feed rod. The table can be either raised or lowered by the operator, and the feed rod will adjust itself. The device is a very simple one, as it consists of a friction box through which passes the feed rod of flat cold rolled. The hooks on the end of the friction box will pull out the rod or shorten it as the table is raised or lowered by the operator. By means of this device, the breakages are prevented which are usually due to the table feeding to the end of the cross-rail, and the nut on the back of the apron striking the end of the cross-rail.

The shaper is manufactured by the John Steptoe Shaper Co., Cincinnati, Ohio.

PORTABLE DRILL REAMER, ETC.

The portable machine, illustrated here-with, is made with various attachments

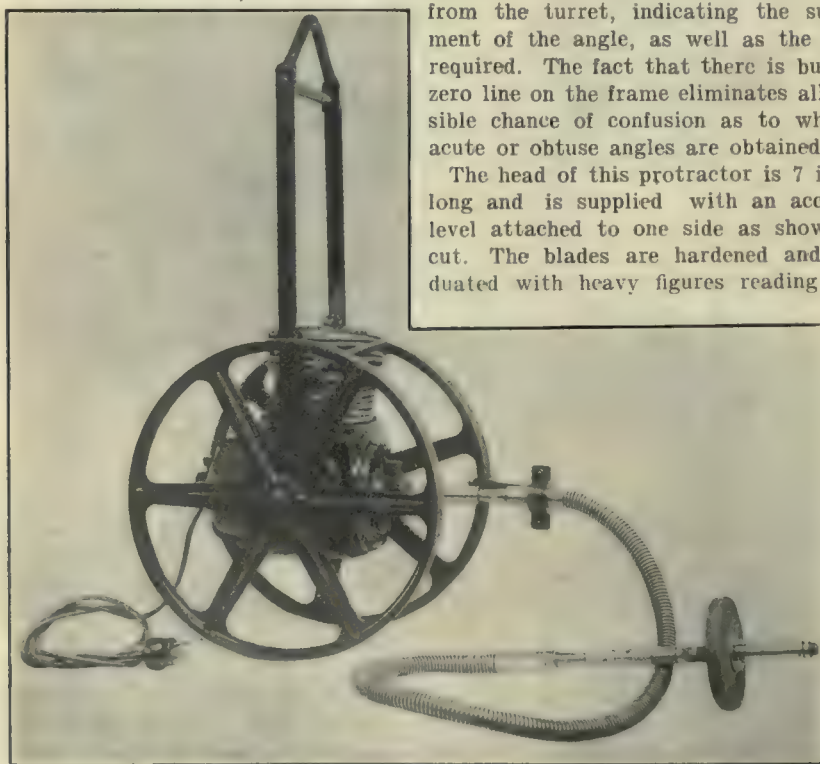

Portable Drill, Reamer, Grinder, etc.

so that it can be used for numerous operations such as grinding, drilling, reaming or as a tube expander or cutter. It is made as a breast drill from

$\frac{1}{4}$ inch down, or as a drill press up to $\frac{1}{4}$ inch.

The illustration shows the machine arranged as a grinder. It is manufactured by the Lancashire Dynamo & Motor Co., 152-4 Bay St., Toronto.

NEW BEVEL PROTRACTOR.

This tool is of the same general design as the Starrett No. 12 protractor, with the additional feature of having the head extend both sides of the blade. This greatly improves the usefulness of the tool, as the same angles may be trans-

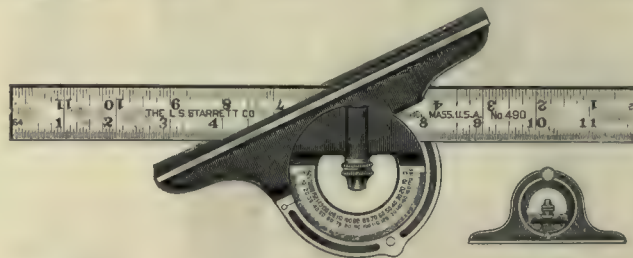

New Bevel Protractor.

ferred from either side of the frame without re-setting. Another improvement is that the turret is graduated to read both ways from 0 to 180 degrees. Mechanics will clearly appreciate this point, as direct readings may be had from the turret, indicating the supplement of the angle, as well as the angle required. The fact that there is but one zero line on the frame eliminates all possible chance of confusion as to whether acute or obtuse angles are obtained.

The head of this protractor is 7 inches long and is supplied with an accurate level attached to one side as shown by cut. The blades are hardened and graduated with heavy figures reading both

IRON FIRMS CONSOLIDATE.

Following the recent consolidations of various iron and steel industries under the head of the Canada Iron Corporation, and the merger of twelve cement companies, comes the announcement of the consolidation of four large iron working companies operating six mills in various parts of Ontario, these being the Toronto Bolt & Forging Co., Toronto, having bolt mills at Swansea (Toronto) and Gananoque, and rolling mills at Sunnyside (Toronto), the Brantford Screw Co., Brantford, the Belleville Iron &

Horseshoe Co., Belleville, and the Gananoque Bolt Co., Gananoque.

These four concerns have been consolidated under the name of the Canada Bolt & Nut Co., Ltd., with headquarters at Toronto, and having a capitalization of \$2,500,000. Lloyd Harris, M. P., of the Brantford Screw Co., is to be president of the new company and T. H. Watson, who recently resigned as manager of the Toronto Bolt & Forging Co., in order to give his attention to bringing about the present consolidation, is to be vice-president and general manager. George Glilies, president of the Toronto Bolt & Forging Co., has disposed of his interests and is retiring.

Further details of the consolidation are not yet completed, but announcement will be made as to the composition of the board of directors after the next meeting. The question of enlarging the Swansea plant is also being considered, but the main changes likely to be made are the concentration of certain lines of work in the different plants, there being at present some duplication in this respect.

When the shop surveyor proceeds to remove a chip or spark from a sufferer's eye, he generally employs a knife blade. If he would have the blade thoroughly magnetized before beginning the operation it would often draw out the source of pain without touching the eye.

POWER GENERATION ^A_N^D APPLICATION

For Manufacturers. Cost and Efficiency Articles Rather Than Technical.
Steam Power Plants ; Hydro Electric Development ; Producer Gas, Etc.

A 10,500 H.P. IMPULSE WATER WHEEL.

The illustration shows a 10,500 H.P. Impulse Water Wheel, which was built in the shops of The John McDougall, Caledonian Iron Works Co., Ltd., Montreal. It is designed to deliver 10,500 brake horse power at 200 revs. per min. under a head of 380 feet of water. It was built for the British Columbia Electric Railway Co., to be used at Lake Buntzen, driving an alternating current generator 5,000 K.V.A., 22,000 volt, 3 phase, 60 cycles.

There are four sets of buckets, all on the same shaft, two on each side of the

area of the orifice and the amount of water discharged. The needles do not make a hollow stream, both are so shaped as to draw the water down to a solid stream before it leaves them. The springs on the needle spindles approximately balance the force of the water on the needles, thus taking the load from the governor. Underneath the wheels, at D, are the needle relief nozzles. These are so connected to the governor that should the main nozzles become suddenly closed the relief nozzles will open and allow the surplus water to run into the discharge pipe preventing shock in the inlet pipes. The needles of these

HANDLING OILS AND TURPENTINE.

A convenient and practical means of handling oils and turpentine has been adopted by Lockwood & Palmer, Stamford, Conn. Three floors are used in the system. On the second floor are five oil tanks holding from 30 to 50 gallons each. These are used respectively for turpentine, boiled oil, raw oil, machine oil and kerosene. An iron pipe runs from each of these tanks down the elevator shaft and then through the wall partition on the first floor, where each end in a brass cock. The oil is drawn off here. The tanks are filled from the equipment on the third floor. An inclined plane, 6 feet long and 2½ feet high at the raised end, leads to a sink directly above the tanks. Each tank has attached a length of corrugated conductor pipe set at the right angle to receive the adjustable pipe which comes from the sink.

When it is desired to fill a tank the pipes are adjusted, a barrel of oil is brought from the cellar on the elevator, rolled up the incline and poured into the sink.

CANADIAN CHROME IRON ORES.

The annual report of the Department of Mines, Ottawa, for the calendar years 1907 and 1908, gives some interesting statistics regarding the output of chromite in Canada. Chrome iron ore is used chiefly for the manufacture of ferro chrome alloys and salts for pigments, as well as for linings in steel and copper furnaces.

Ferro-chrome is produced at Buckingham, Que., by the Electric Reduction Co., and shipments of the ores have been made to the Sydney and Soo steel plants, but their chief markets is in the United States. The ore ranges in value from \$17 to \$20 a ton, for 50 per cent. ore. Chromite is mined in the Eastern Townships of Quebec. In 1907, 7,196 tons were mined, valued at \$72,000. In 1908 a little more was mined.

The world's production of chromite in 1907 was about 90,000 metric tons.

George C. Wells, assistant general passenger agent of the C.P.R. is giving a series of lectures this term to the students in the Railway Department of McGill University, Montreal, on "The Conduct of Passenger Business."

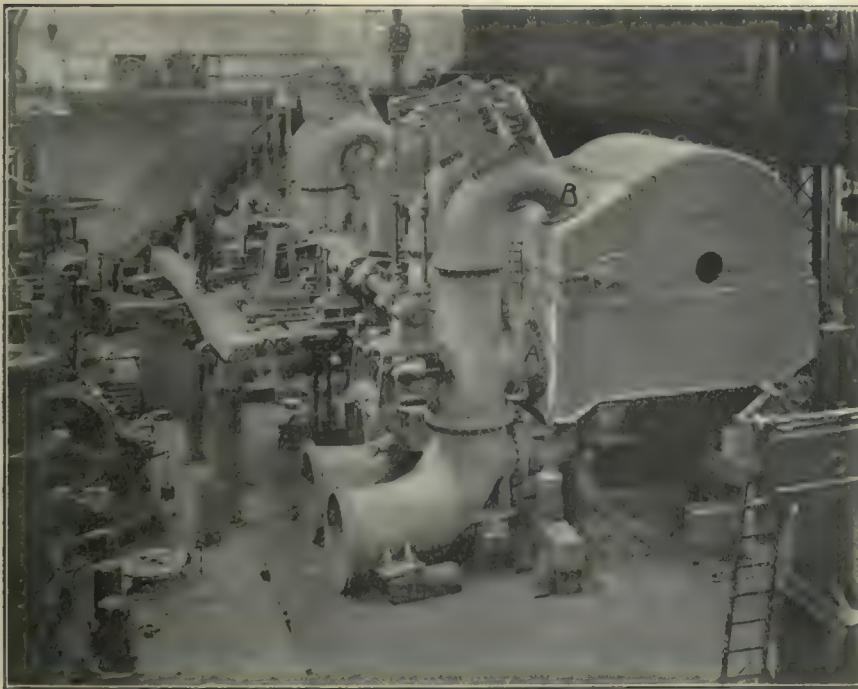

A 10,500 h.p. Impulse Water Wheel.

generator. These buckets are of the ellipsoidal type, and are made of close grained cast steel ground to a smooth finish. Each set consists of 16 buckets, 24 inches wide, forming a wheel 6 feet 10 inches in diameter.

The water enters the casing at A and B and is directed onto the buckets through two needle nozzles. These needles are connected with the Lombard governor through the levers, and lay shaft, as shown in the illustration, and move in a longitudinal direction within the nozzle, thus changing the annular

nozzles are handled by dash pots so that after being wide open they will gradually close, thus preventing shock.

The main shaft is 43 ft. 6 ins. long, 20 inches in diameter at the centre, tapering to 12 inches diameter at each end. It is made of nickel steel, hydraulic forged, oil tempered and runs in four water-cooled bearings. The four cast iron inlet pipes are 36 inches in diameter, and will be bolted to a cast steel yoke pipe, 51 inches diameter. The housings are of cast iron with machined bottom flanges.

FOUNDRY PRACTICE AND EQUIPMENT

Practical Articles for Canadian Foundrymen and Pattern Makers, and
News of Foundrymen's and Allied Associations. Contributions Invited.

FOUNDRYMEN'S CONVENTION.

The annual foundrymen's convention will be held in Detroit, June 6 to 10, 1910, instead of during the week of May 30, as previously announced. The change in date was made in view of the fact that May 30 is Decoration Day, and it is doubtful if many foundrymen would have been present at that time. Arrangements are already being made for the exhibit which will be conducted under the auspices of the Foundry and Manufacturers' Supply Association, and during this week the annual meetings of the American Foundrymen's Association, the American Brass Founders' Association and Associated Foundry Foremen will be held.

CRUCIBLE MELTING FURNACE.

To meet the demands for a melting furnace having a removable crucible, the Monarch Engineering & Mfg. Co., Baltimore, has designed the type shown in Figs. 1 and 2, which is equipped with a crane and for setting the pot into the furnace and for removing the same after the metal has been melted. This

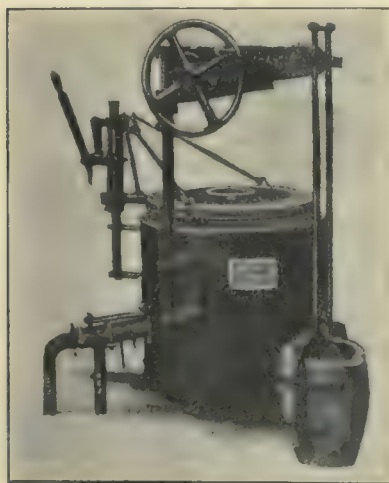

Fig. 1.—Stationary Melting Furnace With Crane in Position to Lift Crucible.

furnace is especially adapted for use in shops where the pot is lifted out and is used for pouring the metal. In Fig. 1, the furnace is shown with the crane in position for lifting the crucible into the furnace, and in Fig. 2, the pot has been raised, the crane swung over, in position to deposit the crucible with its charge into the furnace. The crucible is lifted by a chain attached to the tongs, the chain being wound up on a small drum on the spindle of the hand wheel.

The furnace is provided with a swinging cover, which is moved aside by depressing the lever shown in an upright

American Foundrymen's
Association.

American Brass Founders'
Association.

ANNOUNCEMENT.

On behalf of our association we beg to announce that the invitation so kindly issued by the Foundrymen of Detroit to our respective bodies, to hold the next convention in that city, has been officially accepted by our Executive Boards. The date has been set for June 7th, 8th and 9th, 1910.

The hotel headquarters are to be at the Pontchartrain. Notice of details later on.

With this announcement there are sent the Proceedings of the Associations, and an apology is due for the lateness with which they reach you. The manuscript copy was ready early in August, but at that time the printing office at which our work is done was undergoing a complete transformation, and the monotype machines and new presses have taken until now to get into the running order necessary to turn out our work properly. As our members have all had such experiences in their own shops, we trust the apology may be acceptable.

Detroit promises to be one of the big conventions, as from all accounts the very energetic committee, headed by Dr. Stephenson, of Cincinnati Convention fame, is busily engaged even at this early date. The exhibition to be held during the week of June 6th, also promises to eclipse everything heretofore shown, and hence visiting Foundrymen will be amply repaid, and should make their preparations early.

In the expectation of a very useful and enjoyable gathering, we remain.

Respectfully,

RICHARD MOLDENKE,
Sec. Amer. Foundrymen's Ass'n.
W. M. CORSE,
Sec. American Brass Founders'
Association.
December 10th, 1909.

position in Fig. 1. The opening in the furnace cover permits the products of combustion to escape, and in addition can be used for introducing metal into the crucible, or for inspecting the condition of the metal as it melts. These furnaces can be arranged for installation in pits or above the floor level as

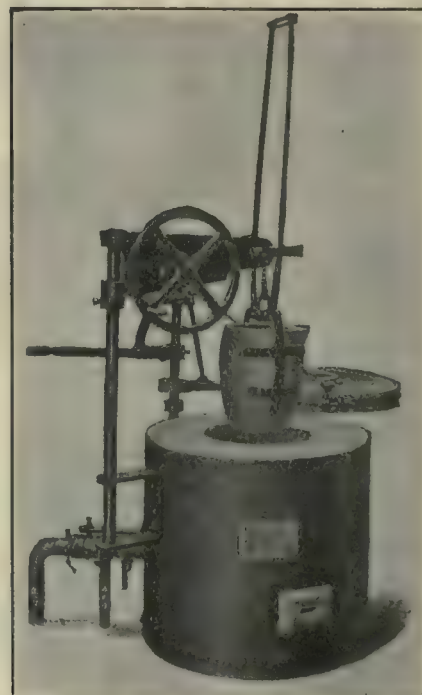

Fig. 2.—Crucible Raised and in Position to be Lowered Into Pot.

desired, and are furnished with or without the lifting crane. Gas or oil can be used for fuel.

FOUNDRY MOTOR.

The motor illustrated herewith is for use in the foundry or in dirty places. It is a pipe ventilated motor, the cut showing the intake pipe at the back. This pipe is connected with the outside of the building; the other end blows the air into the shop if wished, a fan drawing the air in and forcing it out.

This motor is made for direct or alternating current, in all sizes. It is dust proof, being completely covered by a case. One of the features is that it is run with ball bearings and requires lubrication once in two years. Grease is the lubricant and is inserted by removing the small cap at the end of the

bearing. A chimney cooled motor for outside work is built along similar lines.

These motors are being placed on the Canadian market by the Lancashire

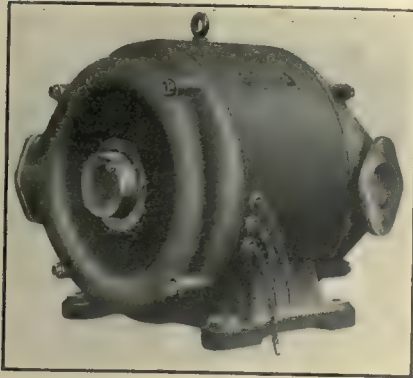

Enclosed Foundry Motor.

Dynamo & Motor Co., 152-4 Bay St., Toronto. G. E. Mason, is manager of the Canadian branch of this company.

CONTINUOUS MELTING.*

By S. D. Sleeth.**

When the Westinghouse Air Brake Co. found it necessary to enlarge their plant, on account of increased business, it was decided to move to Wilmerding, Pa., and install in the foundry flask and sand conveyors. This meant that the foundry would have to run so that iron could be poured all day, instead of two or three hours in the afternoon. We knew of no plant where this was being done, so it was up to our foundry to work it out. As it required about two and one-half hours to run the heat off at that time, we decided to see how much longer we could hold the metal in the cupola and still keep it hot. The first day we put the blast on one-half hour earlier and melted the iron with the same blast pressure, but would shut the blast off for five or ten minutes and then start to blow again. This we found to work satisfactorily for that day. The second day we put the blast on one hour earlier, but this did not work so well, we, therefore, added more coke, which kept the metal hot but the melting was slower.

When we started work in the new foundry at Wilmerding we ran two cupolas, one in the morning, and one in the afternoon. We were afraid to hold over dinner hour. After running for some time in this way we decided to run one cupola all day; at 11 o'clock, or a little later, we added 200 lbs. of coke for two or three charges so that we

would have an extra amount of coke to hold over the dinner hour. Our great trouble at this time was with the cupola man, as he insisted that the iron would freeze at the tapping hole, but we finally persuaded him that he would not be held responsible should this occur. We drained all the iron out at 12 o'clock and closing the slag hole with sand, stopping the tapping hole, and shutting all other openings tight, so there would be no draught. About ten minutes before starting time we tapped out all that was in the cupola and pigged it, then put the blast on full, so as to be ready when the starting whistle blew. Sometimes we have to pig two or three hundred pounds on account of the metal not being hot enough.

We had two sizes of cupola—48 in. and 60 in. inside the lining. When the heats were heavy we would run the 60 in. We had to enlarge the plant again so we took out the 48-in. cupola and installed two new cupolas, the shells being 90 in., so that we could line them up to 78 in. if required. We have them lined at the present time to 70 in. When running full, i.e., night and day, we melt 280 tons, running each cupola about ten hours. We have operated one cupola from Friday night at 6 o'clock until Saturday noon of the following day, closing down at 11 p.m. for one-half hour for lunch, and again at 6.30 in the morning for three-quarters of an hour for breakfast. This is rather hard on the lining so we do not make a practice of it.

We have tried a great many experiments with cupolas, but as yet have been unable to find any that will give better results than the double row of tuyeres—the upper row about 10 in. above the lower. It is not necessary to keep the upper ones open all the time. Our blast pressure is about 11 ounces in the cupola bustle. We use a fan for blast. When running full we melt ten to eleven lbs. of iron to one pound of coke.

In charging the cupola we are very careful to have the charge level. We charge the pig by hand and the scrap is dumped in from a buggy through a door above the regular charging door. All the charges are the same from beginning to the end of the heat. As the iron must come very soft and uniform we do not charge more than 4,000 lbs. at one time. For a smaller cupola the charge would naturally be less.

To sum up our experiences. I would advise: See that the coke bed is burning even all around, then charge just as you would for an ordinary run, allowing an extra amount of coke for the dinner hour. After running about one hour, open the slag hole and keep it open, except during the dinner hour.

Use about 40 to 50 lbs. of limestone to one ton of molten metal—better to use too much than too little. Have the cupola shell large enough, as it is easy to put in an extra lining for smaller heats.

TRADE LITERATURE AS ENGLISH TEXT-BOOKS.

The following unique scheme of teaching English in the Cuban public schools of Habana Province, instituted by the supervisor of English, Miss Abbie Phillips, is reported from Habana:

Miss Phillips has asked all the representatives of English and American manufacturers in Habana to supply her with their catalogs, and especially those which are profusely illustrated. These catalogs are distributed among the schools and students, and a large part of the time devoted to English instruction is used in explaining the names and uses of the articles illustrated.

This seems to offer a rare opportunity for a great deal of free advertising for those manufacturers who are willing to send their illustrated catalogs and pamphlets to the supervisor. The great value of this method of teaching is that the rising generation of Cuban youth will learn the names and uses of the articles illustrated at the most impressionable age, which in the near future will reflect to the advantage of those manufacturers. Miss Phillips states that any kind of catalog is welcome, whether dealing with office supplies or machinery.

It is suggested that interested manufacturers and exporters send a half dozen sets or more of their illustrated literature to Miss Abbie Phillips, Supervisor of English, Obrapia, 57, Habana, Cuba.

PROTECTING POLISHED STEEL WORK FROM RUST.

Polished steel work may easily be protected from rust by the application of the following compound:

Lard 6 parts

Rosin 1 part

The two ingredients are melted together and stirred until cold. The rosin prevents the mass from becoming rancid and also acts as an air-tight film. If rubbed upon a polished steel surface, even very thinly, it effectually preserves and protects the polish. It is easily removed by gasoline or kerosene—Brass World.

W. G. Lotte, instructor in forge practice at the college of engineering, University of Wisconsin, for 17 years, has been granted one year's leave of absence. He will spend the time as special inspector of steel for the International Harvester Co., visiting its various plants in the United States and Canada.

* Paper read before the American Foundrymen's Association. In the February issue will be given a discussion on this subject by Geo. K. Hooper, M.E., New York City.

** Address: Wilmerding, Pa.

Steel Foundry of Vancouver Engineering Works

This New Steel Foundry is the Only One in Canada West of the Great Lakes—Equipment Includes Up-to-Date Cupola, Converter, Cranes, Etc.

The demand for steel castings in the western part of Canada has increased with the rapid development of that section. Machinery used in the lumber and mining industries must be constructed to withstand very heavy work.

portion of the Dominion, early in 1909, the directors of the Vancouver Engineering Works decided to add a steel foundry to their plant at Vancouver. The side blown converter for making steel was adopted.

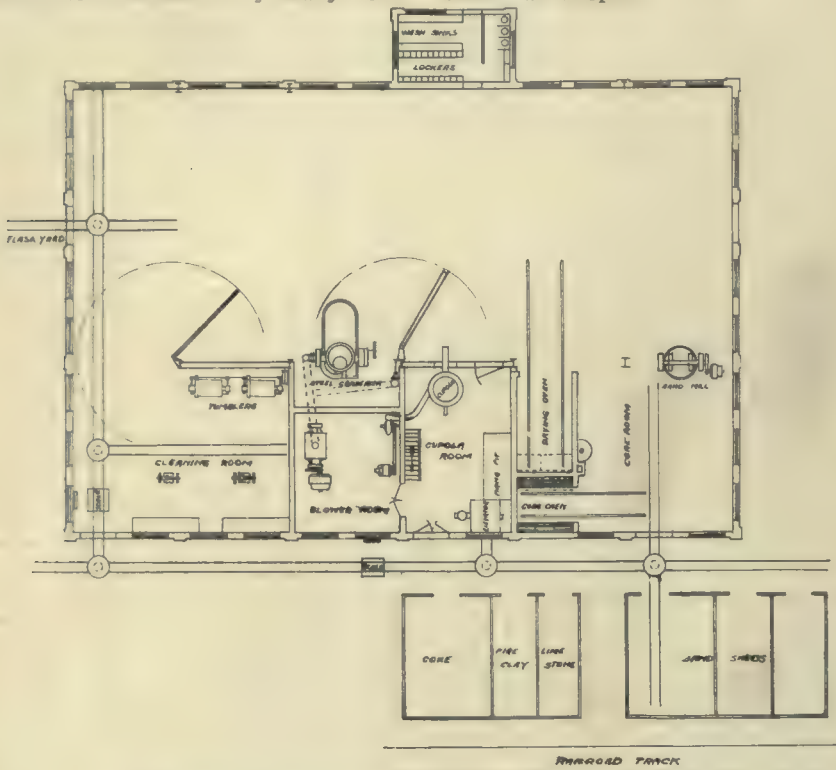

Fig. 1.—Layout of Steel Plant, Vancouver Engineering Works.

Steel castings, which enter largely into the manufacture of this class of machinery, had to be shipped from the eastern part of Canada, or imported from the United States, or England. This was expensive because of high freight rates and long deliveries.

Realizing the growing need in that

In May, 1909, the Whiting Foundry Equipment Co., Harvey, Ill., was commissioned to design and equip the steel foundry according to the most up-to-date practice. Erection of the plant was commenced in June, and the equipment installed during the following September. The first blow of steel was

successfully made October 12th, under the supervision of the Whiting Foundry Equipment Company's Steel Foundry Engineer.

The plant has a present capacity of eight tons per day, and is so designed that extensions for handling double that capacity can be made as required, without interrupting the operation of the present foundry. It is of steel construction throughout, having a main bay 120 feet long, and 50 feet wide, with a side bay 120 feet long, and 30 feet wide,—as shown on the ground plan—Fig. 1. The side bay is designed to provide the most compact grouping of the melting and converting department, the core room, sand mill, and cleaning department, without in any way interfering with the economical operation of each. In the design, every effort was made to secure a continuous system, in order that the raw material might be converted into finished castings without any reverse movements. The steel foundry is so arranged in the plot of the general plant, that the movement of all departments is in the direction of the castings store house.

The Cupola.

The cupola is the standard Whiting No. 4, and the height from floor level to top of the stack is 35 feet. In order to properly charge the converter, the melting capacity is about seven tons per hour. The cupola charging floor is 22 feet long, and 20 feet wide, and is served by a 2-ton electric elevator, having a lift of 16 feet. In order to facilitate the handling of melting stock, an industrial track of 24 inch gauge connects the elevator with the stock yard.

Iron is tapped from the cupola into a 6,000 pound ladle, carried by a pneumatic jib crane of 4 tons capacity, as shown in Fig. 2. Two taps are made to obtain a full charge for the converter. This is done to avoid holding the molten iron in the hearth of the cupola,

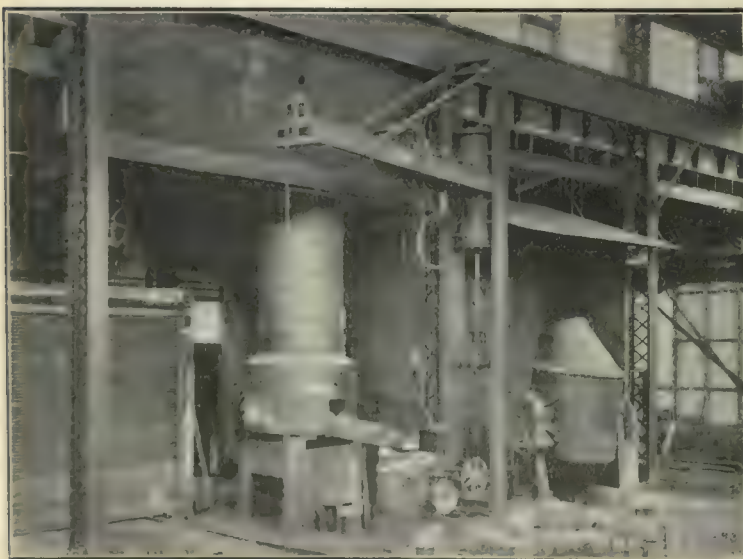

Fig. 2.—Jib Crane of 4 Tons Capacity.



Fig. 4.—Ladle Lowered to Receive Finished Steel.

CANADIAN MACHINERY

where it is exposed to the incandescent coke from which it will absorb sulphur, especially if the manganese content is low. After the ladle is filled, the jib crane hoists it to the pouring position, shown in Fig. 3, and the iron is transferred to the converter, to be blown into steel.

Since no phosphorus or sulphur can be removed, owing to the acid lining of the converter, it is necessary to melt an iron running low in these elements, the maximum limit being 0.04 per cent. for each. The manganese content ranges from 0.60 per cent. to 1.50 per cent. The cupola charge is so proportioned as to give about 1.00 per cent. of manganese, this limit being set because it counteracts the affinity of the iron for the sulphur in the coke, and also minimizes the wear upon the converter lining. As the percentage of sili-

A large hood is suspended above the converter, to carry the fumes outside the building. The height of the converter is 10 feet, when in blowing position. It is lined with a composition of ganister, sand and fire clay, rammed around a wood form. This lining, if repaired when necessary, will give at least 180 or 200 blows.

Iron from the cupola is poured into the converter, which is then turned to an upright position for blowing. The air pressure ranges from 3 to 5 pounds a square inch, it being regulated by a valve at the operator's platform. The blowing operation requires from 15 to 20 minutes, varying with the percentage of metalloids in the iron. It is necessary that the time be as brief as possible, as upon the rapidity of the blow depends the temperature of the bath. Fig. 5 shows the converter during the

pipe connects the cupola with the blower. Regulation of the blast for the cupola is accomplished by means of a standard blast gate.

Core Room.

The core room, core oven and mold drying oven are in the side bay, adjoining the cupola room, and cover an area 40 feet long, and 30 feet wide. The mold drying oven, which holds two cars, is 18 feet long and 10 feet wide, and is fitted with a Kinnear roller curtain door. The core oven is 10 feet by 10 feet, equipped with side shelves for cores, and has a swinging steel plate door. Coal is used for fuel.

Adjoining the core room, is the sand mill room, with a 72 inch mill, built by the Vancouver Engineering Works, Ltd. This mill is of the undergeared type, and is belt driven by a 25 h.p. A.-C.-B. alternating current motor. A

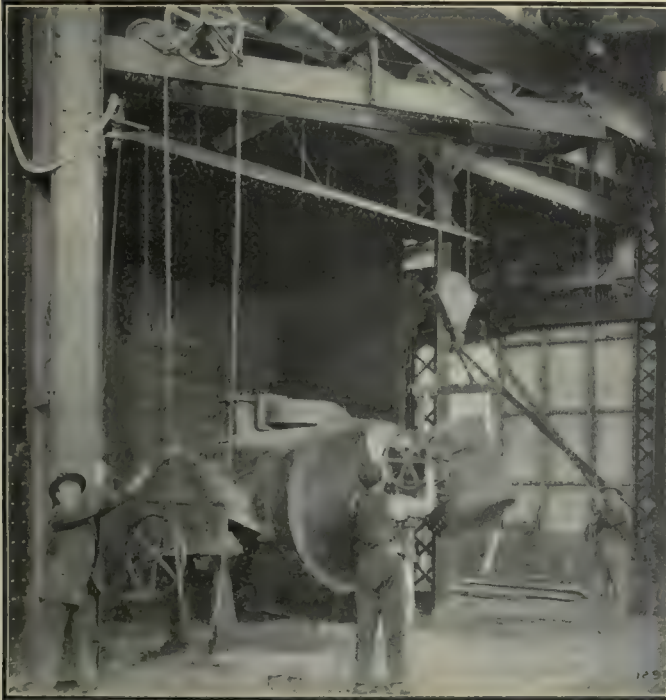

Fig. 3.—Pouring Position Transferring Iron to Converter.



Fig. 5.—Converter During Progress of the Blow.

con in the cupola charge should be from 1.80 per cent. to 2.00 per cent. in the iron it ranges from 1.20 per cent. to 3.50 per cent. The extensive manufacture of boilers, tanks, etc., gives this company a heavy stock of punchings and clippings to draw upon for the cupola charge. In order to produce steel castings of high grade, careful attention is given the sulphur and phosphorus limitations.

The Converter.

The converter, having a capacity of 2 tons, is of the standard Whiting type. It occupies a floor space 20 feet by 12 feet, and is separated from the remainder of the side bay by a steel curtain wall. It is carried on cast steel trunnions, which revolve in heavy cast iron standards, and spans a concrete pit into which the ladle is lowered to receive the finished steel, as shown in Fig. 4.

progress of the blow. Reduction in the weight of metal is about 18 per cent. The steel comes from the converter at 1,700 degrees, centigrade,—a temperature insuring sufficient fluidity to yield sharp, sound castings of light section.

Back of the converter, and on a level with the foundry floor, is the blower room, which is equipped with a positive pressure blower for the converter, and a steel pressure blower for the cupola. The positive pressure blower built by the P. H. & F. M. Roots Co., is a No. 5. It is belt connected to a 75 h.p. Allis-Chalmers-Bullock alternating current motor. The steel pressure blower, built by the B. F. Sturtevant Co., is a No. 6, belted to a 10 h.p. A.-C.-B. alternating current motor.

The blast main to the converter is in a straight line to insure the minimum loss due to friction. A 14-inch blast

pneumatic sand shaker, built by the Hanna Engineering Co. is between the sand mill and core room.

The cleaning room adjoins the blower room, and opens into the main bay. The equipment consists of a cold saw of the 2-B type, and two power hand saws, built by the Quincy, Manchester Sargent Co. Two type C Diamond emery grinders, built by Diamond Machine Co., provide ample facility for grinding the present out-put of the foundry. Provision has been made for the future installation of an annealing furnace.

The Vancouver Engineering Works, Ltd., manufacture an extensive line of logging and saw-mill machinery, all types of boilers, burners for saw-mills, and mining machinery. F. L. Leighton is general manager and installations were made under his supervision.

LOST HIS SUIT CASE.

L. L. Anthes, of the Toronto Foundry Co., has returned from a trip to Calgary and Edmonton, during which he was a member of two hunting parties. While in Winnipeg he, along with Alex. and Garnet Irvine, of the Standard Plumbing Co., and Sam Tait, manager of the plumbing department of the J. H. Ashdown Co., made up a duck shooting party, which visited Findlay, Man., Bob Green, master plumber, of Winnipeg, also being along. He later on went after big game south of Port Arthur, getting a deer, and Alex Cameron, Fort William, a moose. H. Anderson, Port Arthur, also got a shot at a moose, but failed to bring him down. The best Ed. Higginbotham, of Fort William, could get was a snap-shot.

While at Calgary "Lawrie" was initiated into the society, which has recently gained many members in the west, "The Native Sons," the password to whose meetings is the "Indian Sign." Several members of the society came down to the depot to see "Lawrie" off on his trip east, and while waiting for

passed, "Why didn't you make the first casting like this?" The answer will of course depend on many circumstances, but taking a case in point—that of a valve seating shown in Fig. 1, having three machined faces, L, K, and M,—the answer is that, not knowing the parts to be machined were as shown on the sketch, no precautions were taken to ensure these parts coming out clean. It is only when viewing the returned casting that the molder knows anything about these machined faces, as the pattern supplied (Fig. 2) gives no information in this respect. It would be a great help to the foundry if engineers who get their castings made out were particular in having their patterns marked plainly where they are machined, either by printing, say, the word "Bright," or painting all machined parts a different color, attention being drawn to this point on the order accompanying the patterns.

The remedy in this instance is to cast the piece on its side, so that all bright faces are vertical. Fig. 3 is a sectional view of Fig. 4, which latter is a cross-section of the mold complete.

equipment, in issuing a catalogue have included in it useful information for foundrymen. While the "Steel-Harvey" Crucible Tilting Furnace, the Monarch Portable Tilting Furnace, Monarch Non-Tilting Furnace, blowers, etc., are used as illustrations, and the catalogue is an advertisement for these special lines, yet there is a lot of useful information which should be perused by those interested. An article on "The 'Use' and 'Abuse' of Crucibles," contains suggestions worth perusing. The footnote of the opening page, "All goods manufactured and shipped by us are guaranteed as represented, otherwise subject to return at our expense," gives a reader of the catalogue, an impression of genuineness in the contents of the catalogue, and in the goods described.

MAKING PREPARATIONS AT PITTSBURG FOR FOUNDRYMEN'S CONVENTION IN 1911.

The chairmen of the different committees, which will be in charge of the various arrangements for the annual convention of the American Foundry-

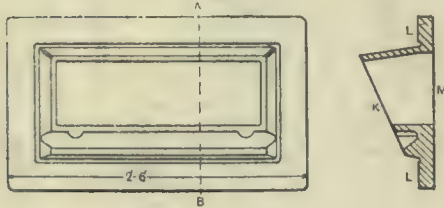

Fig. 1.

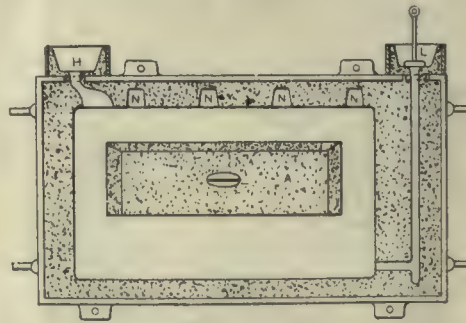

Fig. 2.—Molding a Valve Seating, Fig. 3.

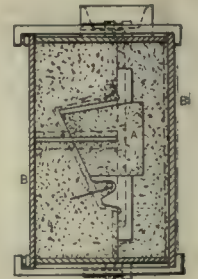

Fig. 4

the train, some one suggested that they have a cigar, so the party went across the road. On the return trip, however, Anthes and his suit case got separated, but he took the train on condition that his friends would send the baggage along on the next train.

"The best laid plans" oft go astray, however, and though "Lawrie" telegraphed from Winnipeg, and went on his hunting trip at Port Arthur, that suit case hasn't arrived yet, and as it contained his camera his friends have to take his word for it that he got "all the law allows" on his shooting expedition.

MOLDING-A VALVE SEATING.

By G. Buchanan.

It sometimes happens that the molder turns out some piece of work for which he is really not responsible, although, when the casting is returned to the foundry and another piece is made which turns out good, the remark is

A is a dry-sand core; B, B are plates which are bedded on to the bottom and top parts of the flask when the mold is being rammed up. These plates are clamped as shown in Fig. 4. Two holes are cut in the flask at the joint, H for a riser and L for the runner. N, N, N, N are dummy risers which take any dirt out of the top flange.

The mold is made in the same way as before when the casting was returned, the same tackle being used. The alterations needed were the holes cut in the flask joint and the two plates bedded as shown to enable the mold to withstand the side pressure when being poured. These pieces weigh 300 lbs., and are made in batches of twelve at a time.—Mechanical World.

MELTING FURNACES.

The Monarch Engineering Co., Baltimore, Md., engineers and specialists in general oil and gas fuel for plant furnace

men's Association at Pittsburg in 1911, were announced as follows at the regular monthly meeting of the Pittsburg Foundrymen's Association, Monday evening, Dec. 6—General committee, Jos. T. Speer, of the Pittsburg Valve, Foundry & Construction Co.; reception, E. A. Kebler, M. A. Hanna & Co.; smoker and get-together, E. D. Frohman, S. Obermayer Co.; finance, J. S. Seaman, Seaman, Sleeth Co.; plant visitation, W. A. Bole, Westinghouse Machine Co.; convention, H. E. Field, Mackintosh, Hemphill & Co.; ladies' entertainment, O. W. Mason, Midland Steel Co.; boat ride, F. H. Zimmers, Union Foundry & Machine Co.; press, W. B. Robinson, The Iron Trade Review.

Louis Lavoie, formerly on the personal staff of the general manager of the I. C. R., has been appointed general purchasing agent of the road with headquarters at Ottawa, Ont., Canada.

CANADIAN MACHINERY

AND MANUFACTURING NEWS

A monthly newspaper devoted to machinery and manufacturing interests mechanical and electrical trades, the foundry, technical progress, construction and improvement, and to all users of power developed from steam, gas, electricity, compressed air and water in Canada.

The MacLean Publishing Co., Limited

JOHN BAYNE MACLEAN, President
H. V. TYRRELL, Toronto
G. C. KEITH, M.E., B.Sc., Toronto
F. C. D. WILKES, B.Sc., Montreal

W. L. EDMONDS, Vice-President
Business Manager
Managing Editor
Associate Editor

OFFICES:

CANADA

MONTREAL Rooms 701-702 Eastern
Townships Bank Bldg

TORONTO 10 Front Street East
Phone Main 2701

WINNIPEG, 511 Union Bank Building
Phone 2786

BRITISH COLUMBIA F. R. Munro
Vancouver

H. Hodgson
Room 21, Hartney Chambers

GREAT BRITAIN

LONDON 83 Fleet Street, E.C.
Phone Central 12960

J. Meredith McKim

UNITED STATES

NEW YORK R. B. Huestis

1109-1111 Lawyers' Title, Insurance and Trust Building

Phone, 1111 Cortlandt

FRANCE

PARIS John F. Jones & Co.,

31bis, Faubourg Montmartre,
Paris, France

SWITZERLAND

ZURICH Louis Wol

Orell Fussli & Co

Cable Address:

Macpubco, Toronto. Atabek, London, Eng.

SUBSCRIPTION RATE.

Canada, United States, \$1.00, Great Britain, Australia and other colonies \$s. 6d., per year; other countries, \$1.50. Advertising rates on request.

Subscribers who are not receiving their paper regularly will confer a favor on us by letting us know. We should be notified at once of any change in address, giving both old and new.

Vol. VI.

January, 1910

No. 1

RAILROAD BUYING A BAROMETER.

No better indication of the prosperity of a country can be found than in the equipment buying of its railroads. When the corporations are launching out into fresh rolling stock, and are providing for increased traffic then there can be no doubt that the trade barometer is favorable. But if the buying is shut down, as was the case last year, then there is no doubt as to the conditions being unfavorable. If railroad economizing tends further to depress trade, railroad liberality has the opposite effect. Not only does it mean that money will be circulating more freely, but that others are encouraged by the action of men who are recognized as leading guides of trade prospects.

For some time now our railroads have been buying heavily, confident in the prosperity wave that has arrived and anxious to be prepared for further improvement. The rolling stock has been greatly added to during the summer and the winter is to be no exception. The C.P.R. are making extensive preparations at their Angus shops, Montreal, to prepare for next year's traffic. They have commenced by placing an order for 15 freight engines and three passenger engines of the Pacific type. Upwards of 150 passenger cars are also to be renovated, and eight new sleepers constructed. A record winter of work is anticipated at the Angus shops, and it is evident that apart from the benefit of this money circulating we have the satisfaction of knowing that much heavier traffic is expected next year.

The Grand Trunk and Grand Trunk Pacific are also making strenuous arrangements as to equipment. During the past four months they have added to their rolling stock at the rate of about \$1,000,000 a month, while orders for new engines and cars have now been given, which will ensure an even greater rate of progress during the balance of the year. Locomotives and cars are con-

tinually arriving and great improvements have been made to the rolling stock. The Grand Trunk Pacific has completed its line between Fort William and Winnipeg, the line being now complete from Lake Superior to Edmonton.

Nor is the Canadian Northern less progressive. That road increased its equipment by 25 locomotives, 1,950 box cars, 500 flat cars, 125 stock cars, 40 cabooses, 16 baggage and mail cars and 15 passenger cars, every one of which was built in Canada. The Ontario division of the road will build during this winter a line to Ottawa, giving thereby a through line between Toronto and Quebec; and the bridging of the gap between Sudbury and Port Arthur (now under construction) will connect the eastern and western divisions, and give the Canadian Northern entrance to the larger centres of the country. West from Edmonton the same line is surveying a route that will take it to New Westminster, so that it is but a matter of months until the third transcontinental railway will connect the Atlantic seaboard with the Pacific.

There cannot be much doubt as to the confidence of the railroads in the future business conditions of the country. The most sceptical can take heart when the shrewd business men controlling these interests make preparations for a greater strain on their rolling stock, for there is this evident fact that unless the country is prosperous, traffic cannot be.

"GRAFT AND GOOD ROADS SEEM STRANGE BEDFELLOWS."

There appeared in a recent issue of the Toronto Globe what appeared to be an authentic account of an investigation of certain charges of graft in connection with the administration of the Oxford county roads system. The article was published under the somewhat startling caption, "Graft and Good Roads Seem Strange Bedfellows." In the course of the evidence reported it was stated that one Jas. A. Vance, "agent of the Hamilton Bridge Works Co.," had sworn that he paid Reeve Sutherland, of East Zorra, \$50 to secure his signature to a contract for a bridge.

The Hamilton Bridge Works Co. affirm that this man Vance was not an agent, is not an agent, and will never be an agent, of the Hamilton Bridge Works Co., and while the Globe is to be congratulated on any steps it takes to expose graft, it would seem that steps should be taken to verify statements made.

It seems that Jas. A. Vance for a number of years was a broker or contractor, going out and taking contracts on his own hook and then buying the steel where he chose. During the past few years the steel for a number of bridges was purchased from the Hamilton Bridge Works. This company on a few occasions gave him contracts to erect some small bridges when he happened to have work in the neighborhood and when it was inconvenient for the company to send its own gangs.

A letter received by the Hamilton Bridge Works Co. from Judge Finkle, chairman of the investigating committee, says that there was no evidence whatever brought out to show that this man was connected with the Hamilton Bridge Works Co. It was therefore unfair, to say the least, for the Globe to publish such an article before endeavoring to find out the full facts. It is a great injustice to the company mentioned to connect them even indirectly with shady dealings. This company has a reputation for fair dealings, not having to resort to any mean or petty acts to secure contracts.

FACTS ABOUT OURSELVES.

Canadian Machinery has entered the sixth year of publication, having, we believe, the confidence of the mechanical men of Canada. From the first, when Canadian Machinery was launched into a distinctly new field, the paper has been a success. From a sixty-four page paper, it has grown to a ninety-six page paper. It is recognized that the support a paper receives from its advertisers is positive proof of its value. In December, 1905, there were thirty-four pages of advertising, while four years later, in December, 1909, there were fifty-eight pages.

When Canadian Machinery was started in January, 1905, there was no machine tool paper in Canada. It is still the only paper in Canada catering exclusively to the machine tool and foundry trades. The quick and ready response with which Canadian Machinery was received by the mechanical men of the Dominion showed that its future was assured. That their interest has not flagged is shown by the fact, that not only have practically all the original readers renewed their subscriptions, but the list has grown until now Canadian Machinery reaches over 90 per cent. of the machine shops and foundries of Canada.

The industrial life of Canada has awakened and factories have been erected by the score during the past year, while a great number more have been planned for 1910. More than twenty salaried subscription men are covering Canada simultaneously, from coast to coast, every city, town and village being visited each year. These men must show results or we want to know the reason why. Besides these men we have a great number of shop agents, and every industrial concern, superintendent, foreman, purchasing agent and master mechanic has the paper brought regularly before his attention. The directors of embryo concerns are also approached, so that we are maintaining a list of paid-up subscribers in Canada, which includes the men who can influence the buying of machine shop and foundry equipment and supplies.

* * *

With the growth of the paper and its increase in popularity among Canadian mechanical men generally, the editorial staff has been increased and greater efforts are being put forward to increase the value of the paper. Results speak for themselves and comparisons of issues as they appear, with previous ones, show a growth in the class of editorial matter published. This has been accomplished by the most diligent efforts on the part of the publishers and by the suggestions received from time to time from friends of the paper. We are always on the outlook for these suggestions whereby the paper may be made of greater interest, and we value the criticisms of our readers.

Among our contributors during the past year we have numbered some of the best known mechanical men of Canada and numerous excellent articles will appear during 1910. We spare no expense to get the mechanical public what they want and we are ever looking for good, live, reliable articles. In every issue is a good fund of

information and ideas for manufacturers, superintendents, foremen and mechanics. As a result, subscriptions continue to come in from all over Canada and our representatives in the various provinces are meeting with excellent results.

* * *

Discriminating advertisers who know where to get results are placing their business with us and each year has shown a growth over the one previous, showing the confidence our patrons have in the advertising power of Canadian Machinery.

While the main function of our advertising pages is to provide a place wherein the advertiser may print his message, we realize that many advertisers, lacking time or inclination to produce good "copy," fail frequently to make the most of the opportunity which Canadian Machinery provides. For that reason we maintain an Art and Advertising Department whose business it is to cooperate with such of our advertisers who desire it, in preparing good advertising copy.

Perhaps the most striking illustration of the efficiency of this department is contained in the fact that many of our advertisers are using the copy prepared for them by the Art and Ad. Department, in other publications besides Canadian Machinery.

* * *

A few kind expressions of opinion received at our office during the past few days, entirely unsolicited, are illustrative of the position held by Canadian Machinery among mechanical men.

W. Dalgheish, Sidney, Man., writes: "I look forward to its monthly visits with a good deal of pleasure, and enclose \$1 to place to my credit. Wishing you continued success."

The following letters were received recently from British Columbia subscribers, at our Vancouver office, 11 Hartney Chambers by H. Hodgson: "Canadian Machinery is a credit to Canada. It is one of the best machinery papers I have seen. It is of interest to every mechanical man whether he be employee or employer."

"Yes, I got the paper all right and like it fine. If every issue is like the October number you can count on me as a permanent subscriber. Moreover, I will get others for you. When you were talking to me I must confess I had no confidence in the paper, but it is ahead of English and United States papers for Canadian mechanical men."

David Williams, one of our eastern representatives, after a tour of New Brunswick, Prince Edward Island and Nova Scotia writes: "There are very few managers or foremen who are not on our list. All of them speak well of Canadian Machinery, especially lately. I have told a number of them that we propose enlarging the department of "Machine Shop Methods and Devices," and they all approve of it. That department has been good lately. The article on the Moncton shops was very much appreciated down here." Mr. Williams is now making a complete tour of the British West Indies for us.

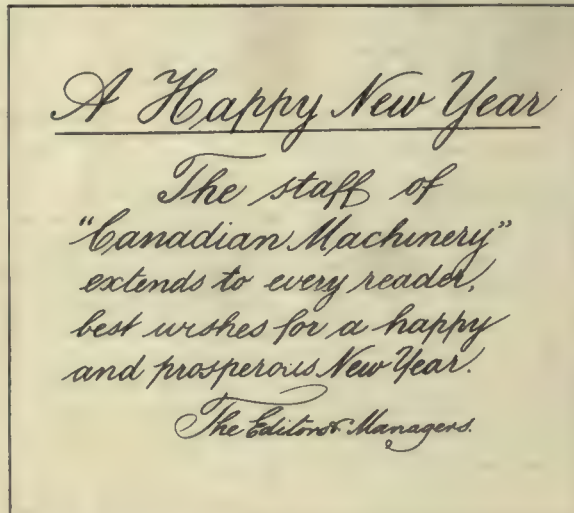

New Interesting Type of Boring and Turning Mills

The Colburn Machine Tool Co., Franklin, Pa., Have Just Brought Out An Entirely New Line of Vertical Boring and Turning Mills, the "New Model."

The "New Model" vertical boring and turning mills recently placed on the market include many new features in their design. There are five sizes in the entire line, 42, 48, 54, 60 and 72-inch swing. With the exception of the method of driving the table, the same features are incorporated in all sizes and a description of any one size practically describes all the others. All sizes are built with two swivel heads, and the three smallest sizes with turret heads as desired.

Referring to Fig. 1, the table spindle has a massive angular thrust bearing which makes it self-centring, and, together with the large, straight, upright bearings, effectually resists vertical, angular and horizontal strains. All bear-

ated with one hand, the belt can be changed from one step of the cone pulley to another with great rapidity and without any injury to the belt. In actual operation the entire range of speeds obtained with the cone pulleys, from the slowest to the fastest and back again, stopping momentarily on each step, has been made in eight seconds. By changing the back gear lever Z, which is in close proximity to the handle which operates the belt shifter, another run of five additional speeds is obtained. A speed index plate, located on the housing directly above the back gear lever Z, indicates the right step on cone pulley for belt and position of clutches inside of speed box to give the correct

hand wheel one revolution, five changes of feed are obtained. A movement of the multiplying lever changes the combination of gears, and another revolution of the hand wheel gives five more changes, making ten in all. The vertical feed shaft extending upward from each feed case engages with mechanism on each end of rail, which conveys motion to the horizontal rods and screws in cross rail, which operate the heads vertically and horizontally. Quick-adjusting positive clutches are used, as shown by D in Fig. 3, which enable the operator to instantly change feed from vertical to horizontal and vice versa. Either feed can be reversed instantly by the feed reverse lever, shown at each end of rail.

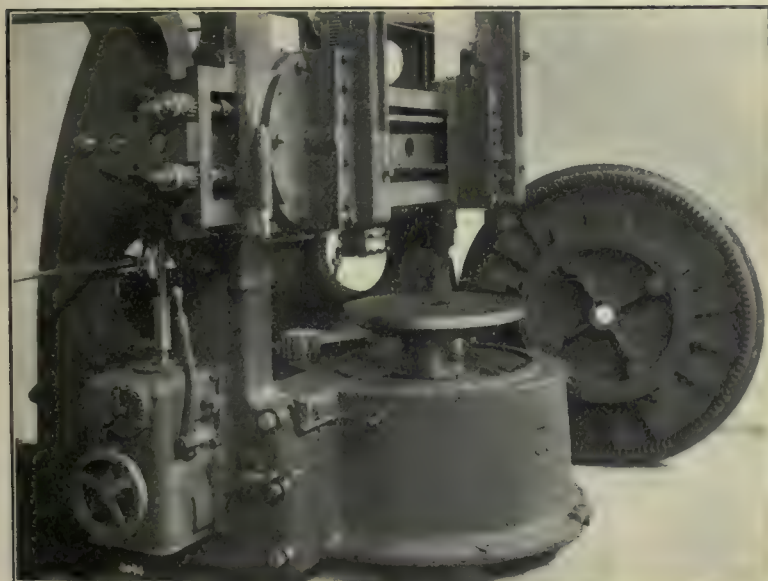

Fig. 1.—Detail of Table Spindle Bearing and Internal Drive as Used on 60 and 72 Inch New Model Mills.

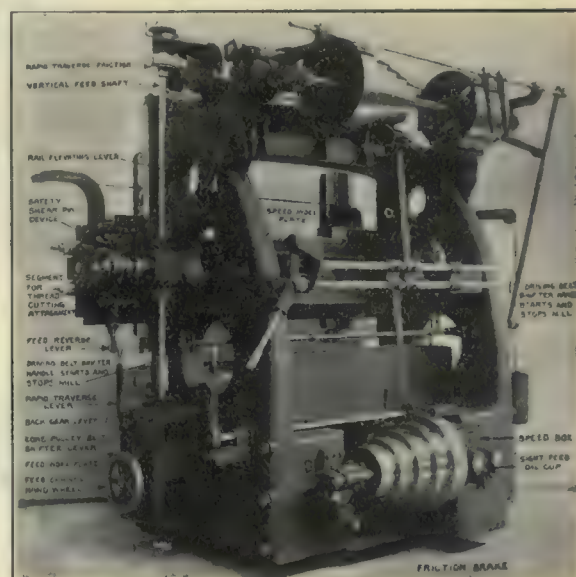

Fig. 2.—Rear View New Model Mills, Colburn Machine Tool Co.

ing surfaces of the spindle are lubricated from one sight, feed oil cup.

Driving Mechanism.

The drive is by means of five-step cone pulleys of large dimensions, thence through the speed box, which contains the back gears and positive clutches, which are constantly immersed in a bath of oil. The back gears are engaged and disengaged by means of positive clutches inside of speed box and operated by lever Z, conveniently located at sides of machine, shown in Fig. 2. Five speeds are obtained with the back gears out, and five more with the back gears in, making ten speeds in all in geometrical progression.

A belt shifter (Fig. 2) is furnished on these mills, by means of which, oper-

speed of table in revolutions per minute.

Fig. 3 shows some of the details of the new model boring and turning mills. A is the right-hand ram and tool holders, B is the friction cone used on foot brake. This has three hard maple shoes or wedges, which are specially prepared by being treated in paraffin. C is a friction cone with cork inserts used on power rapid traverse. These frictions are on the upper end of the vertical feed shafts. D is a quick-adjusting feed clutch, used on the ends of both feed rods and screws on the ends of both rods and screws in cross rail.

The feeding mechanism for each head is contained in a separate case, one on each side of the mill. By turning the

Rapid traverse of the tools, horizontally, vertically, and in angular directions, is obtained from the same vertical shafts as the feed, the manipulation being by a vertical lever attached to the front of the feed case, marked "Rapid Traverse Lever" on Fig. 2. This lever has two operating positions: forward and back. The gear feed is always engaged when the lever is in the back position, and the tool will feed in the direction determined by the position of the feed reverse lever at the end of cross rail.

The rapid traverse is always engaged when the lever is in the forward position, and the tool will travel rapidly in the opposite direction from the gear feed. It is impossible for the operator to throw the rapid traverse in the wrong way, and

there is no chance for an accident to occur.

The motion for the rapid traverse is obtained from the horizontal shaft at the top through friction cones having cork inserts, (see C, Fig. 2). The rapid traverse in connection with the final adjusting collars does away with the necessity of hand cranking, although the ends of the rods and screws in cross rail are squared so that a crank can be used in an emergency or when preferred.

Final Adjusting Collars.

Although the rapid traverse is an indispensable feature, enabling the operator to quickly move the tools in any direction, it does not allow a fine adjustment to be made. In the Colburn mill both feed screws and rods in the cross rail are splined and each has a capstan collar slidably fitted thereto with keys, which fit the spline so that by turning the capstan collars with a small lever furnished for this purpose, the rods and screws are turned also, (see detail, Fig. 4).

A safety shear pin device, Fig. 5, placed on the rear of each end of the cross rail prevents injury to feed mechanism in case the heads are accidentally run together.

Figure 6 shows a new model mill equipped with constant speed motor, mounted on bracket and belted to friction clutch pulley on jack shaft. Friction clutch al-

lows mill to be stopped and started without stopping motor.

WESTERN CANADA RY. CLUB.

The regular November meeting of the Western Canada Railway Club was held in the Royal Alexandra Hotel, Winnipeg, Nov. 8. H. H. Vaughn, assistant to vice-president, C.P.R., Montreal, read a paper on "Fuel Economy on Testing Plants and Railroads." Grant Hall, superintendent motive power, C.P.R., Winnipeg, occupied the chair. On Dec. 13, H. B. Lake, chemist, C.P.R., Winnipeg, presented a paper on "Water Supply."

The next regular monthly meeting of the club will be held in the Royal Alexandra Hotel, Winnipeg, on January 10th, at 8 o'clock. A paper will be read by A. E. Cox, storekeeper, Canadian Northern Railway, on "The Stores Department and its Relation to the Other Departments." There will also be the continued discussion on "Water Supply," and "Copper versus Steel Fireboxes."

John Stewart, heretofore locomotive engineer on the I. C. R., has been appointed acting master mechanic of the Eastern Division with offices at Moncton, N.B., vice Mr. N. L. Rand, master mechanic, placed on the pension list.

Do your work well to-day and you won't have to do it over again tomorrow.

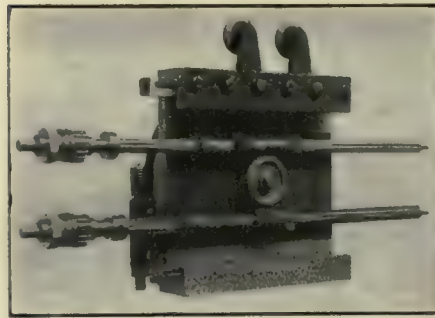

Fig. 4.—Rear View of Saddle for Swivel Head on New Model Mill.

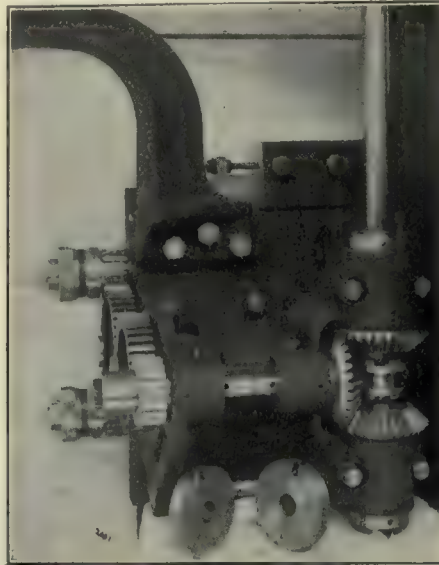

Fig. 6.—View of Safety Shear Pin Device.

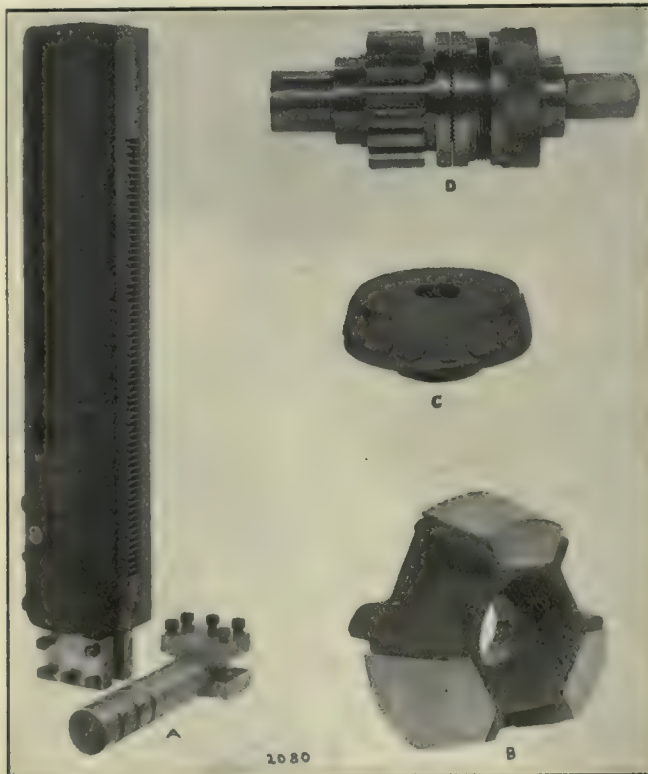

Fig. 3.—Details of New Model Boring and Turning Mills, Colburr Machine Tool Co.

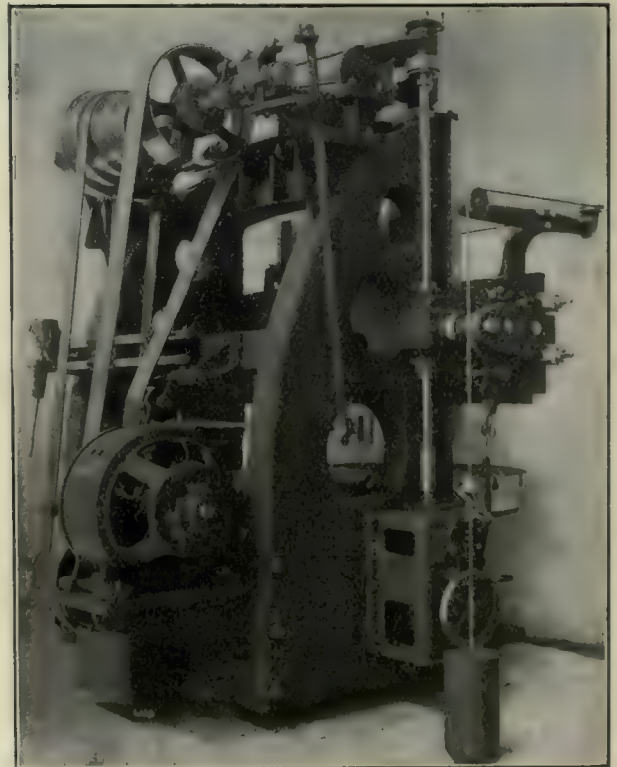

Fig. 5.—Constant Speed Motor Drive as Applied to 54, 60 and 72 inch New Model Mills.

INDUSTRIAL ^A_N^D CONSTRUCTION NEWS

Establishment or Enlargement of Factories, Mills, Power Plants, Etc.; Construction of Railways, Bridges, Etc.; Municipal Undertakings; Mining News.

Foundry and Machine Shop.

The telephone machine factory at Waterford has begun operations.

The Wabi Iron Works, Temiskaming, plan extensions for this year.

The C.P.R. will probably build a new roundhouse at London, in the spring.

The Parkin Elevator Co., Galt, have decided to open a branch office in Winnipeg.

It is officially announced that the C.P.R. will enlarge their Montreal roundhouse next spring.

The Stewart Machinery Co. has applied for a permit to erect a \$30,000 warehouse at Winnipeg.

Extensive improvements have been made to the office floor of the Thos. Davidson Mfg. Co., Montreal.

The Ontario Engine & Pump Co. have decided to locate at Calgary and will buy a big block next spring.

The Regina Machine & Iron Works will have a solid brick or reinforced concrete building put up next spring.

John Dennis, one of Lindsay's pump manufacturers, has moved into his new premises, a modern building.

Work has been commenced on a 13-foot addition to the Provincial Steel Company's plant at Cobourg.

The Page-Hersey Steel Tube Works, Welland, are expected to start work next month with two hundred men.

The Nova Scotia Steel & Coal Co. has struck a 30-foot seam of iron ore on their Wabana property in Newfoundland.

Bonuses aggregating \$300,000, have been offered to any shipbuilding company erecting a plant on Halifax harbor.

The Western Stove Mfg. Co., with headquarters in Portland, Ore., is likely to build a plant at Calgary, for their Western Canadian trade.

The Ontario Iron & Steel Co.'s plant at Welland, which formerly imported its steel billets from the States, are now making their own.

The 1000 Island Boat & Engine Co., Morris-town, has \$10,791.27 worth of orders for spring delivery. They have now a force of over fifty.

The National Iron Works have secured a permit for their first building on the Ashbridge Bay site, Toronto. It is a brick foundry estimated to cost \$20,000.

The first range manufactured by the new stove firm, The Stanford Steel Range Co., Brantford, was recently on exhibition in Howie & Teely's window there.

The Dominion Iron & Steel Co. will have built for next season two 10,000-ton steamers for carrying ore from their iron deposits at Wabana, Nfld., to Sydney.

The Gurney Foundry Co. has been granted a permit to erect a three-storey warehouse to cost \$36,000 on Adelaide Street close to their Toronto works.

The Canada Furnace and Iron Co. burned out a week ago at Three Rivers, are anxious to locate at Farnham, Que. From 300 to 500 men would be employed.

The warerooms of the R. Watt Machine Works, at Ridgeway, Ont., were destroyed by fire on Dec. 10, at a loss of about \$50,000. The machine shops were also damaged.

The Dominion Nail & Tack Co., Galt, have moved into their new factory. Wire nails and drawn market wire will likely be made by the company in the near future.

Mr. Moorehead, U.S. Consul at St. John, is making inquiries at that city for a Wisconsin saw-making concern, which proposes locating a branch factory in Canada.

The Gould, Shapley & Muir Co., Brantford, has decided to erect a large new machine shop on Wellington Street, will enlarge the capacity of the plant for traction engines.

The Union Iron Works Co. is a new concern which proposes to locate at Parry Sound. John Youngson of the Huntsville Engine Works Co., is interested in the new concern.

The Doty Engine Works, Goderich, started its private electric light plant for the first time recently. There are at present about seventy-five incandescent lamps on the system.

McFarlane & Douglas have purchased the property in the rear of their present sheet metal factory, at Ottawa, and plans are in preparation for an extension to the building.

Hudson, Howell, Ormond & Marlett, of Winnipeg, have applied to Regina for a building site on behalf of a client who proposes to erect a large foundry to employ 700 men.

The Canadian Iron Corporation and Mackenzie & Mann intend spending during the coming year \$120,000 on the Big Pier at Port Wade, N.S., for the loading and export of iron ore.

The Ontario Brass Rolling Mills, New Toronto, are again in operation, the plant having been thoroughly overhauled by the new proprietors. Brass rods and sheets will be produced.

The Vulcan Iron Works, Vancouver, have let the contract for the erection of their new plant on the city water lots to W. R. Gilley. It is the intention of the firm to increase their staff.

A by-law to partially exempt from taxation the property of the Burrell Rock Drill Co., manufacturers of rock drills and other mining machinery, will be voted on by Thurlow, Ont., ratepayers on Jan. 4.

The railway Board has dismissed the application of the Grand Trunk Railway for an order, authorizing a connection between the tracks of the G.T.P. and of the Canada Iron & Foundry Co., at Fort William.

T. McAvity & Sons, who have been in the foundry business in St. John, N.B., for a century, associated with the McLean, Holt Co., manufacturers, of the same city, intend to establish a foundry in Fort William.

The sheet steel works at Morrisburg have resumed operations, having been partially shut down owing to making repairs at the power house. Two new rolls have been installed as well as two new furnaces.

D. D. Mann states that the C.N.R. will erect repair shops and a roundhouse in Toronto next summer. Should they be given the right of entry, Ashbridge's marsh will probably be the site on which they will be built.

The Widespread Implement Co., Buffalo, has been negotiating with the municipality of Port Dover, regarding the establishment of extensive works there, consisting of a planing mill, foundry and machine shop.

A report is current that debentures are being floated to the extent of \$2,000,000 in England for

extensive shipbuilding yards and a floating dock at Esquimalt. The B. C. Marine Railway Co. is said to be interested in the venture.

A communication received from Mr. Tennant, financial man for the syndicate which proposes to establish large wire nail and rolling mill plants at Fort William, indicates that the plants are to be established in the immediate future.

McDonald Bros., of Grand Forks, the successful tenderers for supplying the steel piping to be used in conveying the water from Coquitlam Lake to New Westminster, have commenced work on their new factory at the latter place.

J. H. Glover, manager of the Aylmer Pump & Scale Co., was in Toronto recently purchasing a lot of new machinery for the manufacture of scales, which will be placed in the old pork factory building recently purchased.

The Thomas Davidson Co., Montreal, have purchased a block of property adjacent to the works and will extend their plant. The land is at present occupied by dwelling houses, and the price paid was in the neighborhood of \$15,000.

The Ontario Iron & Steel Co., Welland, have let a contract to the Hamilton Bridge Co., to build an extension 170 by 50 feet; also a wing which must be completed by Feb. 1. The company will increase its present pay roll 25 per cent.

Barnett & McQueen will build a large machine shop and warehouse next spring at Fort William. The machine shop will be of reinforced concrete, 50 feet by 135 feet, and two storeys in height. Work on a temporary structure will be started at once.

The Canadian Northern is said to be behind the large purchase of property on the south bank of the Fraser, and a semi-official intimation has been made that immense car shops will be established on the 200 acres held by a subsidiary company.

T. F. Black, Winnipeg, is in Vancouver looking for a site for a wire factory. He may find a location on the Fraser river. Should the proposition go through, it will be financed by a company composed principally of British Columbia men.

George A. Clare, M.P., head of the firm of Clare Bros., stove manufacturers, Preston, Ont., was in Winnipeg lately, and acting in conjunction with his local agents, Clare & Brockett, they secured a site for a large warehouse to be erected shortly.

Four firemen were injured at a fire which broke out at the works of the Canadian Iron & Foundry Co., on Dec. 23. The building was badly damaged, and the loss will be about \$40,000 to the Canadian Iron & Foundry Co., which is covered by insurance.

The Berry Transformer Co., of Helspy, England, one of the largest concerns of the kind in England, is looking for a location in Canada, perhaps in London. This firm will employ 500 men. Sherbrooke, Toronto, Hamilton, Galt and other cities are after this concern.

At a recent meeting of the Medicine Hat Water Commissioners it was decided to equip a machine shop at the power house with a lathe, drill, 7 h.p. gas engine and small tools. It was further decided to accept the offer of the A. R. Williams Machinery Co., Winnipeg, for above.

At a cost of \$1,000,000, the Montreal Street Ry. Co. is about to commence the erection of

a plant, consisting of car-building shops, machine shops, electrical and winding shops, blacksmith and paint shops, and a large building for the stores and material of the company.

The Jordan-Wells Railway Supply Co. proposes to establish a plant either in North Vancouver or New Westminster, with an expenditure of \$50,000, the plant to employ 30 skilled men. Sites are now being looked over. A proposition has been made to the North Vancouver council.

The Morrisburg Tack & Mfg. Co. is now a fully organized concern, with Wm. Eager, president; Irwin Hilliard, secretary, George N. Hickey, treasurer, and C. B. Russell, manager. These officers were chosen at a meeting held last month. The company is capitalized at \$40,000.

The Hayes Mfg. Co., of Erie, Pa., has secured an option on a large piece of land at Montreal on which they will construct a Canadian branch for the manufacture of waterworks supplies, thus escaping the 3% per cent. duty. A \$50,000 plant is to be erected on this land next year.

The Western Drydock & Shipbuilding Co. have filed plans and specifications of the proposed buildings to be erected on their site at Bare Point, Port Arthur. The buildings include a warehouse, blacksmith shop, foundry, pattern shop and storage, office, power house, machine shop, boiler shop and joiner shop.

The Cockshutt Plow Co. is commencing extensions on their plant at Brantford, which, it is said, may result in an outlay of \$100,000, next spring. It is also stated Frost & Wood concern may go to Brantford, owing to recent selling arrangements entered into with the firm by the Cockshutt Co., which may result in a merger.

The Bedford Stove Co. are making extensive improvements to their buildings and manufacturing works at Bedford, Que. They have moved their offices and store rooms into their recently acquired property across the street, which have been fitted up for the purpose, and are remodelling the former offices into a tinshop and show rooms.

It was rumored at London that the Canadian British Insulating Co., of Montreal, would establish a plant there. The company asks for free site, free taxes and free water, for a period of 15 years. In return, they would employ 500 men and use 500 horsepower. They have a capitalization of \$5,000,000, and are looking for a suitable site in Ontario.

R. E. Cushman, representing the Canadian Lead Mining and Smelting Co., has asked the Kingston city council for the lowest cash price the city will make for a smelter site. If the price is satisfactory, and exemption from taxes for ten years is given, the company will guarantee to erect on the site, a smelter, and have it in operation in eighteen months after the property is purchased.

The construction work of the new steel-casting plant at the Londonderry, N.S., Iron Works is nearing completion. The open-hearth furnaces is practically completed, also the coke ovens. After the installation of a sand-mixer, a traveling crane, a metal saw, and some other machinery, the work of casting will commence. The plant will use oil in place of coal for fuel.

W. E. Redway, Toronto, submitted a proposition looking to the establishment of a ship-building industry at Belleville. He wants a free site, \$10,000 worth of dredging done by the city, a loan of \$25,000 without interest, to be repaid at the rate of \$1,000 a year, and exemption from taxes other than school taxes. In return he proposes to build a plant valued at \$30,000.

The Canadian Bond Hanger & Coupling Co., a Canadian branch of the Bond Co., operating in Manheim, Pa., and capitalized at \$75,000, will start operations in February at Alexandria. The directors are: President, Charles Bond, Phila-

delphia; vice-president, John McIntosh, Alexandria; directors, Hugh Munro, Alexandria; Martin G. Hess, and M. T. Williams, of Manheim, Pa.

Dr. Becketl, of Cleveland, representing manufacturers in the wire business in that city, says the Standard Chain Works, of Sarnia, the Canadian branch of the American Standard Chain Co., is to be bought by the company which he represents. The present building is to be immediately enlarged, and a staff of forty or fifty first-class chainmakers will be employed from the outset.

The Waterous Engine Works Co., Brantford., has purchased the Seagrave Fire Apparatus Works at Walkerville, and will remove them to Brantford, where they will be merged with the Waterous works, which will be extended. The company has already secured additional space, including the plant of the Waterous Wire Nail Works which will locate elsewhere. About fifty additional hands will be employed.

At the annual meeting of the Silliker Car Co., held at Halifax recently the financial statement showed a net profit of \$4,000 on the year's operations, which, with a balance of \$14,000 from last year, made approximately \$18,000 of net profits carried forward. The report of the directors recommended the increasing of the capital stock from \$500,000 to \$750,000. This it proposed to do by authorizing the issue of \$250,000 in 5 per cent. cumulative preferred stock. Of this amount it is proposed at this time to issue \$125,000.

Arrangements have just been completed at London, Eng., for the erection of a dry dock at Levis. The interests involved are the Canadian Pacific, the Allans, Harland and Wolff, Sir Charles MacLaren, representing the John Burn Co., of Sheffield; Mr. Davie, of Levis, who conducted the present salvage and dry dock business there, and the McArthur Perks Co., of Canada. The same interests have made a definite proposal to the Canadian government which they expect will be accepted for a dry dock at St. John.

The Canadian branch of the Crocker-Wheeler Mfg. Co., of Ampere, N.J., will be located at St. Catharines. The firm has one contract on hand now for the City of Winnipeg in connection with the big power works. This contract alone amounts to \$250,000. The machinery will be made in St. Catharines, and it will be necessary to greatly enlarge the factory building the company have purchased from the city. While they agree to start with a hundred first-class mechanics, the company say that within a few years they will be employing perhaps a thousand.

The Newfoundland Smelting Co., with a capital of \$100,000, has just been registered at St. John's. The intention of the company is to erect a smelter at York Harbor, Bay of Islands, with a capacity of about one hundred tons a day. The company will get their supply of ore from the York Harbor property, having already one year's supply ahead of them. They also hope to get a quantity of ore from outside concerns, and anticipate that with it will give a boom to the copper mining industries in Newfoundland. The company will export the copper to Swansea and New York.

At a meeting of the directors of the Nova Scotia Steel & Coal Co. held in Montreal, recently, it was decided that as the profit and loss account on Dec. 31, 1908, showed a balance of \$1,219,221 of accumulated profits, a stock bonus or dividend of 20 p.c. to common shareholders be recommended. Each shareholder will receive one share of common stock for every five shares now held by him. It was also resolved to pay a cash dividend of 1 per cent. on the common stock of the company. It was stated that business for 1909 has been fairly good, and notwithstanding the depression which

has existed, the profits will exceed those of last year by at least \$100,000.

Work is rapidly progressing on the new sewer-pipe plant of the Alberta Clay Products Co., Medicine Hat, Canada. All concrete work in connection with the dry-press, brick-machinery room is completed and the machinery for making brick has been set. The plant will be placed in operation as soon as possible so that the remainder of the brick construction work can be done with brick made on the job. As planned, the buildings to be constructed will be as follows: boiler room, 48 x 48 ft.; engine room, 30 x 48 ft.; clay storage house, 140 x 45 ft.; machine room, 50 x 60 ft., and dry-press room 40 x 40 ft. The main building will be four stories high and will measure 80 x 256 ft. in dimensions. The power plant will develop 450 h.p. The drier will use the steam exhaust from the engines during the day and labor steam at night.

Chatham's, Ont., new stove company was formally organized last month. The concern will be known as the Modern Malleable Range Co., and is capitalized at \$40,000. The officers are: President, W. R. Landon, Chatham; vice-president and general manager, Fred Reissner, Leamington; secretary-treasurer, R. Ross, Leamington; factory the Reissner Bros.' stove works at Leamington; directors, Robert Gray, Manson Campbell and John G. Kerr, Chatham. The company takes over the business of the Reissner Bros., stove works at Leamington, having bought that concern's machinery, and will manufacture the "Modern" steel range hitherto manufactured by the Reissner concern. The factory will be situated on St. George Street, immediately opposite the Gananogue Spring & Axle Co.'s plant. The management will remain largely in the hands of Louis and Fred Reissner. They hope to be turning out stoves from the Chatham factory in the course of a couple of months.

Structural Steel.

Three bridges are to be built at Melfort, Sask., by the Government.

Plans have been outlined for a bridge across the Elbow River at Calgary.

The Hull council awarded the contracts for the bridge over Brewery Creek to the Trust Concrete & Steel Co. at \$1,115.

Saskatoon citizens have voted to issue \$18,000 of bonds for the erection of a footbridge on Twentieth Street.

The B.C. Provincial Government is about to construct a suspension bridge at Chilliwack to replace the one washed away.

The contract for the ornamental iron work on the Chateau Laurier, Ottawa, has been awarded to the Canada Foundry Co.

Sherbrooke ratepayers are petitioning the city council for a new bridge across the St. Francis River to replace the old Aymler bridge.

The contract for the structural steel in connection with the addition to the Montreal Arena skating rink has been awarded to the Dominion Bridge Co.

The Canadian Bridge Co., Walkerville, has been awarded the contract for the superstructure of the Cambie Street bridge at Vancouver at \$439,210.

H. C. Stone, Montreal, has awarded the contract for the steel work on the extension of the Beardmore building to the Dominion Bridge Co., of Lachine.

The contract for the extension to stores at 1133 St. Catherine street west, for the David Ouimet Estate, have been awarded. The steel work goes to the Phoenix Bridge Co.

The Montreal City Council will ask the C.P.R. Co. to construct a bridge from La-Croix to Montcalm streets, in order to maintain the traffic on Notre Dame street.

Work has begun on the pile driving in preparation for an iron bridge to be placed over the Dudgeon Creek, on the Salisbury and Albert Railway at Hopewell Hill, N.B. The bridge is to be a 50-foot span.

The tender from the Jenks-Dresser Co., of Sarnia, for \$1,000, for the supply, erection and completion of steel floor beams and posts for the new engine room at the main pumping station at Toronto was accepted.

It is understood that the C.P.R. has made Guelph a most important proposition to protect the Eramosa road and Heffernan street crossings by the erection of overhead bridges if the city will undertake the responsibility of protecting Allan's crossing.

The Ontario Railway and Municipal Board ordered the City of Guelph and the Guelph Radial Railway Co. to forthwith construct a new four-span steel bridge over the Speed River on the Dundas road, in accordance with the report of F. L. Somerville, C.E.

F. H. Barnes, C.E., has made an examination of the proposed bridge sites at Victoria for the Trinity Valley road, finding the suggested locations suitable and estimating the cost of the bridge at \$5,000. It is believed that the bridge will be built by the Government this season.

The Western Iron Works Co. are completing the ornamental work on the new Canada Permanent building at Winnipeg, and have commenced the erection of elaborate ornamental work on the new McArthur building. They are also filling many important contracts in Calgary and Edmonton.

Tenders for the substructure of the new Quebec bridge, of which the estimated cost is to be \$10,000,000, and which is to be completed in four years, were delivered to the Department of Railways and Canals in Ottawa, November 30. The weight of the superstructure to be carried will be 130,000,000 lbs., whereas the weight of the superstructure of the bridge that collapsed was to be but 70,000,000 lbs. The cost of the steel in the new bridge is to be about \$7,500,000. Nickel-steel is to be largely used. It is expected that tenders for the steel work will be called for about May 1.

Planing Mill News.

The Bruce Mines Sawmills Co. have just completed a new plant.

Russell & Son are erecting a heavy portable sawmill at Thornloe, Ont.

Hewson-Campbell & Dail have started a shingle mill at Aldergrove, B.C.

A permit has been granted Elliott & Son, for a furniture factory at Toronto.

Keenan Brothers, Owen Sound, are building a sawmill at Miller Lake, Ont.

The Golden Lake Lumber Co., Eganville, Ont., are making additions to their mill.

A new planing mill and sash and door factory is to be erected shortly at Vancouver.

A. and F. Fraser are about to construct a sawmill at the head of Hazley's Bay, near Pembroke.

An up-to-date shingle mill is being added to the Harriston Lake, B.C., plant of the Rat Portage Lumber Co.

The Globe Furniture Co., of Walkerville, Ont., have sold their plant and are planning to continue elsewhere.

The Brooks-Scanlon Lumber Co. are planning to erect a large sawmill on the Fraser River at New Westminster.

The Saginaw Salt & Lumber Co. are to expend about \$15,000 in improvements on their sawmill at Thessalon.

Hugh Baird & Son, Markdale, Ont., intend to erect a sawmill at Thornbury, with a capacity of 50,000 feet daily.

U.S. capitalists have about completed arrangements for the erection of a large basket and box works at New Westminster, B.C.

Donald Fraser & Sons will erect another mill at Fredericton, to take the place of the Aberdeen mill which was destroyed some years ago by fire.

The Canadian Pacific Lumber Co.'s saw and shingle mill at Port Moody, B.C., which has been closed down for some months, will resume cutting early in January.

The Hunting Lumber Co. whose sawmill was recently destroyed by fire, will build a new mill on a site recently secured on Burrard Inlet, between Barnet and Port Moody, B.C.

Mount Forest ratepayers will, on January 3, vote on a by-law to aid the enlargement of Leslie Brothers' planing mill and factory, in that town, by granting them free water for the use of the factory, and a limited assessment and taxes.

Negotiations have been in progress for some time with Senator Thompson for securing the Estey mill site near Fredericton, for the erection of the new mill which a company that is being organized intend to erect there next spring.

The Royal City Shingle Mills, New Westminster, B.C., have been temporarily closed down while the machinery is receiving its annual overhauling. New boilers and smokestacks are being installed.

The dry kiln and heading mill at the Wallaceburg Coopera Co.'s plant, Wallaceburg, Ont., have been destroyed by fire. The adjoining mills were saved through the efforts of the fire department. The heading mill is a complete loss, but will be rebuilt.

Irwin & Sons, of Hornings Mills, have purchased the building formerly occupied by S. Hill as a sash and door factory at Markdale, and will fit up the building with modern machinery for the manufacture of skewers, fork handles, etc. They will employ 20 hands or upwards.

The Canada Woodenware Co., whose plant at Ossekeag, N.B., was burned in June, 1907, is being reorganized, and sufficient capital is being secured to build an up-to-date plant at South Bay, N.B. George C. Weldon, president of the S. Hayward Co., is president of the company, and William Brown, of Hampton, will be in charge of the business.

Statistics of the lumber industry in British Columbia show that the total number of sawmills is 204; capacity, approximate average, 8,080,000 feet a day; shingle mills, 45, with a capacity of 2,250,000 yearly, logging camps, 265; donkey engines and logging locomotives, 267; horses employed, 1,500; men employed, 17,000; number of mills closed, 17.

John Bell, of A. G. Lambert & Co., Nelson, B.C., and Thomas B. White, of Johnson, White & Co., manufacturers of hardwood lumber, staves and hoops, Kolapore, Ont., have acquired from the Boundary Development & Exploration Co., of Greenwood, B.C., a ten-acre mill site near Midway, in the Boundary district, and will erect a good-sized sawmill before spring.

The North Pacific Lumber Co., of Barnet, B.C., who were burned out recently, are rebuilding their plant and are expected to use electric drive. They have placed their order with the Vancouver office of the Allis-Chalmers-Bullock, Limited, for one 600 k.w., 3-phase, 60-cycle, 2,200-volt standard engine type alternating current generator, one engine type direct current exciter generator, and a three-panel switchboard for the control of generator, exciter and power circuits.

Upon the re-opening of traffic in the North Arm, which is now blocked by the construction of the new bridge, the Westminster shingle mill on Lulu Island, B.C., will commence operations. The mill will have a daily capacity of 150,000 shingles. Six shingle machines are included in the plant. It is the intention of the company to erect a large lumber mill shortly, to which the shingle mill will be an auxiliary. Construction will probably be started in the spring.

The B.C. Gazette gives notice of the incorporation of the following companies: Christie & Co., capital \$40,000, incorporated to construct, build and operate sawmills, shingle mills, sash, door and box factories and operate the same; J. A. Dewar Co., capital \$250,000, incorporated to carry on the business of timber merchants, sawmill proprietors, shingle mill proprietors, lumbermen, manufacturers of woodenware in all or any of its branches, pulp or paper manufacturers, etc.; Sechelt Logging Co., capital \$5,000.

Another large deal in Newfoundland lumber has been closed by American capitalists. Canadians are also interested. The National Vulcanization Corporation, of the United States, and the Lumber Securities Corporation, are associated with the purchasing interests, and pulp and saw mills and vulcan-

izing plants will be put into operation as soon as possible. Some of the principals of these companies were in Toronto recently to consider the establishing of Canadian plants controlled by a Canadian company, which is now in process of formation. The Newfoundland operations would have in view only the market of the Atlantic seaboard. Other plants may be erected in Ontario and British Columbia. The Newfoundland undertaking is capitalized at \$5,900,000, and the Canadian company, with head offices in Toronto, at \$1,000,000.

General Manufacturing News. . .

The Manitoba Pump & Windmill Co., Brandon, is extending its premises.

The J. B. Snowball Co. will erect a grist mill at Chatham, Ont., next fall.

The construction of the Welland glass works will be commenced next spring.

The Tudhope Carriage Co.'s works at Orillia started operations last month.

The San Francisco Stone Co., is considering a proposition of starting a plant at Calgary.

The manufacturers of the Chamberlain weather strip propose locating a branch factory at St. John.

J. Scott, of Port Huron, Mich., proposes establishing a refrigerator manufacturing plant at Camrose, Alta.

Joseph Little, of Blairmore, B.C., contemplates establishing one of the largest lime burning industries in Canada, at Frank, Alta.

The pulp works at Swanson Bay (Prince Rupert) of the Canadian Pacific Sulphite Pulp Co., are now working to their fullest capacity.

A Vancouver syndicate, Auld, Gwynn & McLarty, representing the Northern Oil Co., are looking for a site for an oil refinery near Esquimalt.

Ald. Martin, Cobalt, will erect a \$50,000 hotel before next spring, the building to be six storeys in height, of fireproof construction throughout.

Prescott ratepayers will on January 3 vote on the question of granting aid to the Ogdensburg Soda Pulp Co. to establish a branch factory there.

The Collins Mfg. Co., Toronto, have moved into their new factory on Symington Avenue, adjoining the C.P.R. tracks, in the north-western part of the city.

Mr. Sterett, of the Independent Asphalt Co., Seattle, is looking into the possibilities for locating a branch plant at Vancouver, to cost in the neighborhood of \$40,000.

M. Townsley & Son, Minneapolis, manufacturers of cable lightning arrestors, are looking over the ground at Brandon with a view to finding a location for a branch.

The Winnipeg Oil Co. have made application for a site at Moose Jaw, where they will erect a plant, with storage, cooperage, barreling and also a tank, capacity, 12,000 gallons.

The new plant of the Sydney Slag Brick Co., at Sydney, C.B., which has been under construction the past several months, is now completed and the manufacture of brick has been commenced.

The Brandon Shoe Co., whose factory was destroyed at Aymer by a boiler explosion, will go to Brantford, backed by local capital. A site has been secured and a new factory will be erected as soon as possible.

The D'Israeli Asbestos Co., Que., have placed a contract for locomotives and cars in New York, necessary for their railroad. The equipment is expected in February, when everything will be ready for starting operations.

The People's Ice Co., financed by well-known business men of Toronto, with the assistance of practical ice manufacturers, have decided to erect a plant at that place to produce "Absopure" ice, under rigid sanitary conditions.

A creosoting plant will be erected on Burrard Inlet, B.C., at a cost of several hundred thousand dollars. In association with several Vancouver capitalists, H. E. Rood, head of

the Pacific Creosoting Co., of Seattle, will be in charge of the undertaking.

Among the British concerns which intend to locate branches in Canada are Doulton & Co., makers of the famous Doulton ware; Maw & Co., one of the largest makers of fancy tiles, and Hope & Co., of Birmingham, manufacturers of locks and ornamental iron work.

The new fuel testing plant of the Department of Mines at Ottawa has been completed, and it only remains to instal the machinery. The first use which will be made of the building will be to demonstrate that peat is an ideal fuel for the production of power gas. Already 70 tons of peat have been delivered at the building.

Two new industries will commence operations in Berlin during the next few weeks. The Berlin Fuel Savers Co. have leased part of the old market building and will make the new fuel saver and heat generator, which has been patented; and Wm. J. and Fred. Witte have returned from Newark, N.J., and have leased a flat, where they will manufacture high-grade buttons.

The West Canadian Co., which operates coal mines at Lille and Bellevue, and is opening a new mine at Blairmore, has under way the construction of an entire new operating plant at its Bellevue collieries, which, when completed, will constitute probably the finest mining equipment yet installed in The Pass. The plant will include the most modern appliances for the expeditious and economical handling of coal, and when ready for operations will enable the company to put on the cars 2,000 tons of coal on an eight-hour shift. The improvements complete will entail an expenditure of approximately \$250,000.

Port Arthur's industrial committee has closed an agreement with the Canadian Linen & Paper Co., represented by E. P. Bender, Winnipeg; Dr. Phar, Winnipeg; H. F. Forest, Winnipeg, and Prof. Meygret, France, to locate a manufactory there for the making of linen and paper from flax. The company gets 50 acres site free, but no bonus, except tax elimination. It will start May 1, 1910, on the erection of a \$50,000 plant, and will spend \$250,000 in five years and employ at least 150 men. The company will use an entirely new and secret process, making linen at a greatly reduced cost. One of the principal reasons in coming here is to get water and air free from alkali.

Trade Notes.

The Canadian Inspection Co., have removed their Toronto offices from 37 Melinda St., to Stair Bldg., cor. of Adelaide and Bay Streets.

Smith, Kerry & Chace, consulting engineers, Toronto, have opened up an office in the Winch Bldg., Vancouver, which will be the head office for Western Canada.

J. L. Goodhue & Co., Danville, P.Q., makers of the brands "Extra," "Standard" and "Aemie Waterproof" of leather belting, have been incorporated under the name J. L. Goodhue & Co., Limited, with capital of \$150,000. There will be no change in the management.

G. E. Mason, representing the Lancashire Dynamo & Motor Co., has opened up offices at 152-4 Bay St., Toronto and will manage the Canadian business of this company. They specialize in motors and dynamos; motors being constructed for machine tools, foundries, etc.

The Soledad Mining & Milling Co., Mexico, have installed complete mills for amalgamation and cyanidation, the machinery consisting of four Nissen Stamps, machinery complete for re-grinding, steam power plant, electrical equipment, the complete order being placed with Fairbanks-Morse & Co.

The Standard Engineering Co., 47 Wellington St., Toronto, have installed in the works of the Montreal Mills Co., 1—No. 6, type R stoker horseshoe furnace; 1—No. 6, type R stoker bolt furnace; 1—No. 6, type R stoker nut furnace, making the fifth order from this work. In ad-

dition the Standard Engineering Co. have made a number of large instalations of stoker fired steel heating furnaces in the United States.

The Mumford Molding Mch. Co., has been organized and will sell the foundry molding machines heretofore sold by the E. H. Mumford Co., Philadelphia. The machines will be manufactured by the Q.M.S. Co., at Plainfield, N.J., and the Mumford Molding Mch. Co., will have its sales office at 30 Church St., N.Y. W. D. Sargent is president, and E. H. Mumford, is vice-president and general manager of the new company.

The Canadian Fairbanks Co., announce that they have been appointed the exclusive sales agents for Canada for Dicks' Balata Belting and have purchased the business of J. S. Young. All orders in the future should be sent direct to their nearest branch house. Large stocks are carried at the present time at Montreal and Vancouver, and stocks are on the way to the branches at St. John, N.B., Toronto and Winnipeg.

New Companies.

Jones Hardware Co., Uxbridge; share capital \$11,000.

Cassiar Coal Co., Toronto; capital, \$2,000,000; to develop coal and mineral properties. Incorporators, A. Dods, R. McKay and G. Grant, Toronto.

Colonial Transportation Co., Ltd., Toronto; share capital, \$100,000; provisional directors, A. M. Boyd, M. P. Arnold, M. McPhee, R. B. Henderson, and W. W. Sloan.

Canada Pipe and Steel Co., Toronto; share capital, \$100,000; provisional directors, J. L. Ross, A. W. Holmsted, O. R. Bickerstaff, W. L. Carr, and E. M. Carruthers.

The Universal Electric Economy Co., Montreal; capital, \$20,000; to manufacture electrical appliances. Incorporators, E. F. Surveyer, G. V. Cousins and C. A. Hale, Montreal.

The Thetford Asbestos Syndicate, Montreal; capital, \$100,000; to develop asbestos properties in Quebec province. Incorporators, G. V. Cousins, C. A. Hale and P. F. Brown, Montreal.

The F. and L. Co., Toronto, capital, \$75,000; to manufacture and deal in products of iron and wood. Incorporators, Jas. Fowler, Toronto, and Jas. Wilson and W. B. Campbell, Detroit.

The Electro-Steel Co., of Canada, Toronto; capital, \$100,000; to treat, smelt and refine mineral ores by electric process. Incorporators, J. S. Lovell, W. Bain and R. Gowans, Toronto.

The Stratford Carriage & Motor Co., Stratford; capital, \$100,000; to manufacture carriages and automobiles. Incorporators, M. L. Evely, F. J. Walker, and Alex. Faill, Stratford.

Morrisburg Tack Mfg. Co., Morrisburg; capital \$40,000, to manufacture and deal in tacks, brads and small nails. Incorporators, Wm. Eager, G. N. Hickey and Andrew Broder, Morrisburg.

The Automatic Gas Co., Montreal; capital, \$100,000; to manufacture and deal in gas engines, etc. Incorporators, W. Farwell, Sherbrooke; and F. Paul and W. G. McConnell, Montreal.

The Shawinigan Cotton Co., Montreal; capital, \$1,000,000; to construct and operate cotton and woollen factories. Incorporators, A. O. Calder, T. E. Gadbois, and Oscar Gagnon, all of Montreal.

Canadian Bond Hanger and Coupling Co., Ottawa; capital, \$45,000; to carry on business of founders, machinists, millwrights, etc. Incorporators, W. C. Perkins, M. C. Edey, and A. W. Fraser, Ottawa.

Calgary Power Co., Montreal; capital, \$3,000,000; to build and operate an electric light, heat and power company throughout Canada.

Incorporators, E. F. Surveyer, G. V. Cousins and C. A. Hale, Montreal.

Lethbridge Collieries, Ltd., Montreal; capital, \$3,000,000; to take over the Lethbridge Collieries Co., and operate coal, oil and mineral properties. Incorporators, E. F. Surveyer, G. V. Cousins and C. A. Hale, Montreal.

The British Columbia Gazette contains notice of the incorporation of W. J. Pendray Co., with a capital of \$500,000 to take over the business carried on by W. J. Pendray under the trade name of the B.C. Soap Works and the British American Paint Co.

McKinnon, Holmes & Co.

McKinnon, Holmes & Co. have formed a limited company under the above title with J. W. Bowman, President; G. D. McKinnon, P.A.Sc., Vice-President and General Manager; and A. R. Holmes, C.E., Secretary and Treasurer. Their offices and works are located at Sherbrooke, their specialty being steel plate and structural work, including construction of bridges, water tanks, water wheels, boilers, elevators, etc. Steel shapes will be carried in stock for immediate shipment.

An Industrious City.

"Turn Wellandward," is one of the neatest recent booklets issued by any industrial centre. In Welland, at least a dozen branches of United States industries have been established during the three past years. Its population has increased over 300 per cent. in the past five years. Among the industries illustrated are M. Beatty & Sons, Ontario Iron & Steel Co.; Robertson Machinery Co.; Canada Forge Co.; Canadian Billings & Spencer; Plymouth Cordage Co.; Supreme Heating Co., etc. Welland is in the electric zone and is one of Canada's growing cities. The interesting booklet, full of information, is issued by J. D. Payne, Secretary Board of Trade, and B. J. McCormick, Industrial Commissioner, Welland.

New Wire and Nail Plant.

Negotiations are in progress for the erection of a wire and nail plant at Fort William. Prominent Montreal capitalists, including H. S. Holt, president of the Montreal Light, Heat & Power Co., and F. W. Thompson, second vice-president and managing director of the Ogilvie Milling Co., are interested. Interviewed on the project, Mr. Holt said that they were progressing as rapidly as possible, but it was impossible to say how soon they would commence the erection of the plant. Mr. Holt further said, "The advantages of a plant at Fort William are threefold. There is cheap fuel, and cheap raw material, for the Soo Corporation will soon erect a steel rod mill at their plant, which will give us raw material practically at our doors. We will also have cheap water power. No definite plans have yet been drawn up, but we are progressing as fast as possible with negotiations."

New Coke Ovens at Soo.

The Lake Superior Corporation has placed a contract for the installation of a system of by-product coke ovens, at the Soo plant. The apparatus will consist of a series of 110 ovens, arranged in two batteries, each of 55 ovens. The type of oven will be the same as is being erected at Gary, Ind. The cost of the plant will be about \$1,500,000. The charge of coal for each oven will be about 13 tons, making a total charge for the 110 ovens of over 1,400 tons of coal. The yield of coke per oven will be about 10½ tons, or nearly 1,200 tons per day. For the generation of industrial power nearly 10,000,000 cubic feet of surplus gas will be available. Indicated by heat units, the quality of this gas represents a heat value of about 200 tons of good coking coal. The distinguishing feature of this system is the extraction of ammonia direct from the gas in the form of sulphate of ammonia, without the employment of a

water scrubbing process. An improvement in the coke quenching arrangement will also be instituted, so that instead of having a coke bench the coke will be pushed into a coke quenching car. It is expected that the plant will be in operation by January, 1911.

Tallman Brass & Metal Co.

Tallman Brass & Metal Co., which occupied quarters on Wellington street north for 13 years, have opened up their large new factory and foundry on Wilson street, east of Sanford avenue, Hamilton, and are quickly getting down to hard work to execute the many orders they have on hand for the winter trade. Tallman Brass & Metal Co. manufacture Arctic metal, and in their new establishment have more than doubled every branch of their business. The Arctic metal department has been increased to four times its previous capacity. The metals used by this enterprising firm are imported direct, and the company does a fine jobbing business in tin, lead, copper and aluminum ingots and antimony. Brass castings are a specialty and the instalment of new and up-to-date machinery and equipment enables the company to turn out orders in quick time in the best of style.

The very latest machinery, including an ore crusher, which effects a great saving in metal, has been installed, and the brass furnaces are of the latest pattern. All gases and fumes are carried outside of the building by special blowers.

Type metals, all grades of solder and ingot metals are manufactured in the new plant. A fireproof pattern storage vault has been built and the whole place is practically fireproof and equipped with fire and burglar alarms.

Another Canadian Industry.

The Northern Aluminum Co., which recently established offices in the Traders Bank building, Toronto, and which has secured large orders for aluminum wire for the Hydro-Electric power system, intends to inaugurate an active campaign to introduce their cooking utensils to the retail hardware trade in Canada. For the present the stock will be imported but a site has, it is understood, been selected for a Canadian factory at either Niagara Falls or Brockville, near their existing plants at Niagara Falls and Massena, New York. The company already has furnaces and a wire plant at Shawinigan Falls, Quebec. The Northern Aluminum Co. has already introduced its kitchenware in Toronto, and other cities.

The Northern Aluminum Co. is a branch of the Aluminum Company of America, whose headquarters are at Pittsburg, and which recently declared a stock dividend of 500 per cent. and gave notice that it would increase its capital from \$3,200,000 to \$25,000,000. The company is now paying the equivalent of 24 per cent. per annum on its common stock, which sold some months ago as high as \$350 per share and in 1907 at \$500 per share. The declaration of a stock dividend has been expected for the last three years, but was delayed by the 1907 panic and is part of the general plans of the company to enlarge the scope of its operations. The stock dividend entails the issuance of \$16,000,000 additional stock, bringing the outstanding common up to \$19,200,000. In 1904 the company had but \$1,600,000 common outstanding, but declared a 100 per cent. stock dividend in that year.

The company, through one of its subsidiaries, recently applied to the Canadian Government for the privilege of damming the St Lawrence River below Brockville, so as to create 80,000 horse-power to be used at Massena, where the company has a \$5,000,000 investment.

In spite of the expiration in February last of the patents under which aluminum has been made in the United States, the Aluminum Company has not as yet met with any new competition.

The present capacity of the Aluminum Company is understood to be about 20,000,000 lbs. per annum, which is nearly 40 per

cent. of the world's total production of aluminum. Last year, however, the company did not output more than 8,000,000 lbs., and at the present time is not operating more than half its capacity. Through reductions in price the company expects to popularize the use of aluminum and greatly increase its output.

CATALOGUES.

DROP FORGE OPEN TURNBUCKLES—Price list with sizes of turnbuckles from Canadian Billings & Spencer, Welland.

UNDERWRITER STEAM PUMPS—Bulletin 35 from Canada Foundry Co., Toronto, describes the Underwriter Steam Pumps from 500 to 1,500 gal. per min. capacity.

BRIDGES & STRUCTURAL STEEL—Circular from the Hamilton Bridge Works showing a bird's-eye-view of their works, including the new buildings recently constructed.

HYATT STANDARD BUSHINGS—Bulletin 300M describing the high duty type of Hyatt standard bushings, has been issued by the Hyatt Roller Bearing Co., Newark, N. J.

BEAM AND COLUMN DATA—This book of data is sent with the compliments of Ernest McCullough, C.E., chief engineer Northwestern Expanded Metal Co., 930 Old Colony Bldg., Chicago, Ill.

PUNCHING AND SHEARING MACHINES—Catalogue on bond paper, describes punches and shearing machines, universal boller-makers' tools, rolls, etc., manufactured by the Covington Machine Co., Covington, Va.

HORIZONTAL MILLING MACHINES—A folder from the Fosdick Machine Tool Co., Cincinnati, Ohio, gives the features of No. and 2 Horizontal Boring, Drilling and Milling Machines recently described in Canadian Machinery.

FIRE CLAY, BRICKS—James Douglass & Sons, Bonnyside Fire Clay Works, Bonnyside, Scotland, represented in Canada by S. Galbraith, 73 Dupont St., Toronto. The catalogue contains 134 illustrations of firebrick shapes, etc.

ELECTRIC FURNACES—A catalogue issued by the American Electric Furnace Co., 45 Wall St., New York, and Niagara Falls, Ont., describes and illustrates in large half tones the Kjellin, Colby and Roehling-Rodenhauser systems.

RECORDING INSTRUMENTS—Bulletin 103 issued by the Bristol Co., Waterbury, Conn., deals with recording instruments for blast furnace, plants for steam and blast pressures. Record charts are illustrated, besides a number of other recording instruments.

PORTABLE TOOLS—S. Obermayer Co., 641 Evans St., Cincinnati, Ohio, have issued a catalogue of their Peerless A.C. and D.C. electric tools. These include illustrated descriptions of chipping hammers, hand drills, breast drills, reamers, grinders, etc.

MOLDING MACHINES—Catalogue 23 from the Arcade Mfg. Co., Freeport, Ill., describes the modern molding machine. The catalogue is an interesting article on the molding machine illustrated throughout with the Arcade machine. The jolting machine is also described.

STANDARD GAUGES—Accuracy is the keynote of the catalogue describing the "Johansson" combination standard gauges manufactured by Gronkvist Drill Chuck Co., 18 Morris St., Jersey City, N.J. Different gauges are described and illustrated with their applications.

EMERY WHEELS—No. 20, from Prescott Emery Wheel Co., Prescott, Ont. The catalogue deals with emery wheels, grinders and polishers of all kinds and various attachments for grinders. Prices are given for the different machines. This is a good reference catalogue which should be kept on file.

STEEL DRILL RODS AND SPRING WIRES—W. N. Brunton & Son, steel wire manufacturers,

Musselburgh, Scotland, have issued a catalogue of cast steel drill rods and silver steel rods for drills, taps, etc. Sizes, prices and directions for hardening are given. Steel wire in any size is made by this company, the many shapes being illustrated in their catalogue.

REFRIGERATION MACHINERY—Catalogue A from the Vilter Mfg. Co., Milwaukee, Wis., describes refrigeration and ice making machinery. The catalogue is well illustrated showing the progress of work through their shops and completed machinery for various systems. Systems are also given. The catalogue is full of information in regard to ice machinery.

CHUCKS—The Skinner Chuck Co., New Britain, Conn., 1909 Price List, 4 x 7 1/2, 48 pages. Lathe, drill and planer chucks, face plate jaws, reamer and assembling stands, and drill press vises. Each different style of chuck is illustrated by half-tone cuts. The company also makes special chucks for holding automobile gears and parts, in addition to those shown in list.

FUEL OIL AND GAS BURNING APPLIANCES—The W. S. Rockwell Co., 50 Church Street, New York City, is sending a pamphlet to the foundry trade, which illustrates a few of the latest types of Rockwell furnaces, fuel oil and gas burning appliances. A number of views of fuel oil and gas burners, as well as Rockwell fuel oil pumping system are also included.

NEW TOOLS—The L. S. Starrett Co., Athol, Mass., have issued a booklet describing the new tools for machinists and engineers recently placed on the market. These include protractors, gauges, verniers, micrometer, calipers, dividers, etc. Descriptions of a number of these appeared in recent issues of Canadian Machinery. Copies of this booklet will be sent on request.

MILLING MACHINES—Catalogue 17 from Kearney & Trecker, Milwaukee, Wis., is a handsome volume, 80 pages, 6 x 9 ins., printed on bond paper. The catalogue is very complete, showing the growth of the Kearney & Trecker milling machine. Following this is a description in detail of their millers, each part being illustrated. Instructions are given for their operation.

ANNEALING AND HARDENING FURNACES—W. S. Rockwell, Hudson Terminal Building, 50 Church St., New York, have issued a pamphlet dealing with furnaces suitable for annealing, hardening, tempering or case-hardening of tools, taps, dies, punches, machine parts, etc. The furnaces can be operated with either gas or oil as fuel. Full information as to size, gas or oil consumption, etc., is given.

TOOL HOLDERS—Armstrong Bros. Tool Co., 339 N. Francisco Ave., Chicago, have issued a new catalogue No. 18, listing, with prices, tool holders for turning, planing, boring, slotting, threading, cutting off and drilling metals. Among the new goods listed in this catalogue are automatic drill drifts, pages 68 and 69, plain drill drift, page 67 and standard reversible ratchet drills, pages 60 and 61.

GEAR CUTTING MACHINES—1909 catalogue No. 1, of machines designed and manufactured by Newark Gear Cutting Machine Co., 66 Union St., Newark. This company was formerly Eberhardt Bros. The catalogue contains illustrated descriptions of automatic spur, bevel, skew and face gear cutting machines, hobbing machines, etc. Tables and rules of gearing are included, making a very complete reference catalogue.

CONVEYING MACHINERY—Catalogue No. 81 General Chain Catalogue from the Jeffrey Mfg. Co., Columbus, Ohio. Contains full description and price lists of their various types of chains and conveying machinery, trucks, hoists and other accessories contingent on the rapid handling and transmission of raw and finished products. The book contains 368 pages and is profusely illustrated. They have also issued bulletin No. 18 descriptive of the Jeffrey electric and air power coal cutters. This illustrates the cut-

ters in actual service and describes fully the method of operation. Copies on request, if this paper is mentioned.

GRINDING MACHINERY—Diamond Machine Co., Providence, R. I., catalogue of grinding and polishing machinery, comprises floor grinding machines, motor driven grinders, wet tool grinders, automatic face grinders, locomotive guide bar grinders, roll grinders, surface grinders, gun barrel machinery, internal grinders, lathe grinder attachments, drill grinders, polishing and buffing machines, polishing wheels, emery wheels, strapping machines, disc grinders, etc.

FOUNDRY BETTERMENT—Knoeppel & Knoeppel, Foundry Specialists, Erie, Pa., have issued an interesting booklet, "Foundry Efficiency Through Betterments in the Engineering and Accounting Branches." As stated on the front of the booklet, "Chemistry of results is just as important to the success of the foundry as a business, as chemistry of iron is to the success of the melting operations." The booklet deals with the betterment of foundry service and may be had by mentioning Canadian Machinery.

MACHINERY—The Waterbury Farrel Foundry & Machine Co., Waterbury, Conn., have issued a general catalogue of 205 pages, 6 x 9 ins., hard covers, printed on bond paper and well illustrated. It forms a general reference book, briefly reviewing their most prominent types. These are divided into several classifications from A to U. Separate catalogues have been

issued giving detailed information, these catalogues being indicated by a letter. Section A deals with automatic cold press nut, bolt and rivet machinery, B machinery for manufacturing hinges and butts from sheet steel and brass, C cartridge machinery for making metallic cases, etc., D drop presses, F foot presses and screw presses, G chain draw benches for tubing and rods, H hydraulic draw benches, K knuckle joint embossing presses, L lathes for burnishing, knurling, etc., M single acting open back power presses, N single acting blanking and drawing presses, P double acting power presses, R rolling mills, S shear presses and alligator shears, T finishing machinery, U muffles, casting shops and furnaces.

BOOK REVIEWS.

THE PREVENTION OF INDUSTRIAL ACCIDENTS. By Frank E. Law, M.E., and William Newell, A.B., M.E. Published by the Fidelity and Casualty Co., New York. Price 25 cents.

This is a paper covered book of 190 pages and contains 72 illustrations. It contains a large amount of useful information in regard to the prevention of accidents in various kinds of manufacturing and includes boilers, engines, elevators, together with wood-working and metal-working machinery. Every manufacturer, his superintendents and his foremen should read this book for the information and suggestions that it contains.

Canadian Machine Tool Markets

THE METAL SITUATION.

Despite the usual dullness of trade in December, very fair buying has characterized the metal markets. Stocks being low, except in the case of the larger interests, metal is being wanted all the time, and thus trading keeps busy. From inquiries received it is evident that all classes of consumers are keeping a very close watch on the markets. A very strong tone has developed in all metals, and it looks as if 1910 will show higher prices all the way round.

The home pig iron and steel situation has continued firm through the month. Although there has naturally been some falling off in new business, orders on the books are so heavy that this is not regretted. Delivery is behind hand, and furnaces and mills are contracted away ahead. Imported business is on the quiet side as the larger users filled up their stocks before the close of navigation, but it is evident that before long they must come into the markets again, and pay the enhanced prices. Steel billets are hard to procure. The home plants are out of the open market, and in consequence Continental billets are finding ready sale. The billet situation promises to be a serious one in 1910.

Tin has been fairly active, and the rising prices towards the end of December brought in some extra business. The primary markets were marked by a strong jump in London, caused by some heavy buying on the part, it is said, of a syndicate. This buying is probably to anticipate a good consumption demand later on.

Copper has been rather quiet, but steady business has been done. Prices were advanced under the rumor of the great billion-dollar merger, and although the merger report seems to have lost ground somewhat, prices have not. Producers have not abated their output, and heavy stocks are overhanging the market. Spelter has remained under very strong control both in London and St. Louis, and the firm prices in these markets have been reflected in Canada. The domestic galvanizing interests have bought heavily, and are expected to be in the market again before long, owing to the good

trade in the finished articles. Lead has been fluctuating, and is the least satisfactory of all the metals. The demand has been fair, but prices, although advancing, have not done so in a confident way. Imported and Trail lead are now commanding the same price.

MONTREAL.

With the advent of the holidays the general machinery trade in this district has displayed a tendency to simmer down. This fact, however, must not be taken to indicate that deliveries will be hastened. The factories hereabouts and those supplying the dealers here have plenty of orders that will keep them busy for a long time to come without any new business at all.

For a great many machine tool makers and dealers this is inventory time, and the time of the year when most travelers are in from "the road." Many buyers defer placing of business until after stocktaking time, and this, too, has a quieting effect on the trade. Records and inventories show that the past year has been a very good one, particularly the last six months. Regarding the prospects for next year, even the most conservative men in the trade are sanguine that 1910 will be a record-breaker in machinery lines.

Power equipment has felt the same influence as machinery, although a good volume of business was signed this month, particularly in small units. Inquiries are numerous, but the actual orders resulting from these will probably be held over into the new year. Steam specialties are enjoying marked activity, in fact, the last two months' business has been exceptionally good, and 1910 is expected to continue in the same satisfactory manner.

Prices in both machinery and power supplies show a tendency to ease a little, this being due to the fact that the large volume of work, such as is on hand, lowers the cost of production proportionately and salesmen are able to quote better discounts.

Increased business is leading to increased facilities for handling the same. One of the

larger of the extensions contemplated is that of the Montreal Steel Works. They have secured a splendid tract of land of about 36 acres in Longue Pointe, East Montreal. The land is bounded in front by the St. Lawrence River. The tracks of the Montreal Terminal Railway, and the Canadian Northern cross at the north giving first-class shipping facilities. It is expected that ground will be broken as soon as the frost allows.

TORONTO.

While business is a little dull around the holiday season, yet the year closed with a good volume of business. The Government trade returns show large increases of each month in 1909 over the corresponding month in 1908. It is expected that the opening of the year will see a great increase in the buying.

Canadian railroads will soon be on the market, placing some large orders. The C.N.R. and G.T.P. are arranging terminal facilities and repair shops, and some good orders for heavy machinery will no doubt be the result. It is expected that the first of the C.N.R. shops will be located in Toronto. This road has been rapidly extending its lines, and has yet no repair shops. Attention must soon be given therefore to repair shops for rolling stock.

In the United States the leading manufacturers of lathes recently announced an advance in prices. The reason given is that many improvements have been made in lathes. Sensitive drills have also been increased. There is no question about the recent improvements made in lathes, the one of to-day having more than double the capacity for work over the one of two or three years ago.

Industries generally in Ontario are busy and there is a good demand for foundry supplies and equipments. The jobbing foundries are busy supplying castings, and machine shops are busier than they have been for two years.

The municipalities in the Hydro-Electric zone in Western Ontario are working together and as soon as the transmission line is ready for delivery, large orders will be placed for electrical equipment. Several British companies have opened up offices in Toronto and are getting a share of the orders for electrical machinery and equipment now being placed.

METAL NOTES.

The Northern Electric Co., of Regina, has been awarded the contract for the wiring of the public building at \$1,098.

Ingersoll ratepayers will vote on a by-law for a civic power distribution plant in January. It is estimated that the plant will cost \$26,000.

Aylmer, Ont., town council has decided to rebuild the water and light plant destroyed in the explosion some weeks ago, and will install steam driven machinery as before.

Ottawa electors will on January 3 vote on a by-law to grant the Metropolitan Electrical Co. the right to construct and operate an electric heat and power distribution system.

On March 1, 1910, the Ontario Power Co. must begin the delivery of current to the Hydro-Electric Commission, which has contracted with the company for 30,000 h.p., at \$10 a horsepower. The company is now generating 72,000 horsepower. The second tube will just double the output of the plant. The charter of the Ontario Power Company permits it to develop 200,000 horse-power.

It was agreed by the Hamilton board of works to instal 52 street lamps in the Crown Point and Kenliworth districts. The lamps will be taken under the contract with the Cataract Power Co. at the contract price of \$47.50 a lamp a year.

At a special meeting of the Bridgeburg Board of Trade which considered the proposed franchise to be given the Canadian-Niagara Power Co., allowing them to transmit electricity through the village, the submission of a by-law to the people was favored.

The Canadian Niagara Power has applied to the Council of Bridgeburg for the privilege of using the streets, highways and public places for the purpose of supplying electricity for light, heat and power. The electors will vote on this question on January 3.

Prince Rupert will shortly have electric light again if negotiations now proceeding between the people of the northern town and the Prince Rupert Sash & Door Co. reach a successful issue. Recently the mill of the B.C. Tie & Timber Co. at Prince Rupert was burned and the electric light plant, which was in the mill, was a total loss.

The Canadian General Electric Co. was awarded the contract for supplying the civic power house at Woodstock, Ont., with a complete five panel switchboard with instruments and regulators; 3 300-kw. transformers; two 1,500-gallon per minute turbine pumps, each driven with one 175-horse-power motor and one 500-horse-power motor to drive the present generator for the sum of \$20,000.

Contracts for supplies were recently awarded at London. The Northern Electric Co. was awarded the contracts for 5-16-inch guy wire for \$122.50; 1/4-inch wire strand at \$76.50; light strain insulators, in three sizes, at \$105, \$120 and \$107.50, a total of \$332.50, and the Canadian General Electric were awarded the solid guy wire, No. 9, at \$26.30; anchors, medium, at \$58.41; heavy anchors at \$26.93, and guy wire clamps at \$20.80.

The Dominion Government have under construction at Chambly Canton, Que., a new power house to take the place of the present one. The capacity will be about 150 horse power generated by a turbine water wheel. The power will be used in the Chambly canal workshops at Chambly Basin and for lighting the canal and government property. The superintendent in charge is Mr. E. Duchesneau. At the time of writing (Dec. 20) no appropriation has been made by the government for the equipment but it will probably go through this session.

The St. Johns, Que., Electric Light Co. have placed a proposition before the town council anent the better lighting of the streets. The company offers to change all the 32 c.p. lamps for 60 c.p. To do this the town would be required to purchase new brackets and lamps, which would amount to \$600 or \$700. The company would supply the wiring

and defray the cost of erecting them, the lamps then to become the property of the company. Under this arrangement it would cost the town \$13 per 60 c.p. lamp per year, instead of \$12 per 32 c.p., as now paid.

The East View Council has given the first reading to the by-law for an agreement with the Ottawa Electric Company. There will be practically two contracts. One is for ten years, for lighting houses and stores, etc., in East View. The company is to have an exclusive franchise for five years and the rates charged are to be the same as those paid by Ottawans for lighting of stores, dwellings, etc., here. There is also an agreement for lighting the streets of East View with 100 watt Tungsten lamps at \$13 each a year. It is claimed that Ottawa now pays \$15 annually for a 6-watt light, so it is asserted that the new contract is a fairly good one for East View. The property owners will vote on this on January 3.

The work that the Ontario Power Co. is doing in the Park at Niagara Falls is almost as big as the original venture. Superintendent H. H. Wilson now has 350 men on the job and in the course of a month will have many more in his force. Work will be continued through the winter and Mr. Wilson expects to have it completed some time in July of 1910. In round figures the work means an outlay of \$1,500,000. The second tube in which the company is working represents an engineering feat that is unique. The first tube was of steel eighteen feet in diameter, 6,500 feet in length. The second tube will be of reinforced concrete and of the same dimensions of the first tube. So far as is known no concrete tube of that diameter has ever been built.

A. S. M. E. ANNUAL MEETING.

The annual meeting of the American Society of Mechanical Engineers was held in New York, Dec. 7 to 10. A list of the papers presented appeared in the December issue of Canadian Machinery. The officers for 1910 are: Geo. W. Westinghouse, president; G. W. Baker, E. D. Meier, W. F. M. Goss, vice-presidents; J. S. Bancroft, J. Hartness, H. G. Reist, managers; W. H. Wiley, treasurer.

Among the papers presented was one by Henry Hess, on "Line-shaft Efficiency, Mechanical and Economic," which states that the co-efficient of friction of plain babbitted or cast iron shaft bearings ranges from 1/2 of 1 per cent. to 8 per cent., and that a plant having a coefficient of 3 per cent. is one to be proud of. The remedy for this excessive friction is stated to lie in using ball-bearing hangings on line shafting.

A test conducted by Dodge & Day on a line of 27-16-inch shaft 72 feet long

is described in detail, with the following general conclusions. The saving due to changing ten 27-16-inch plain ring-oiling babbitted bearings running at 214 revolutions per minute to ball bearings increases with increasing belt tension from 14 to 36 per cent. With the usual belt tensions of good practice ranging from 44 to 57 pounds per inch of width of single belt the saving amounts to 36 per cent. and 35 per cent.

The paper concludes with a comparison between the use of ring-oiling and ball bearings on a dollars and cents basis. Here it is shown that taking electric current at a cost of 3 cents per kilowatt-hour for 3,000 hours, the ball bearing returns a saving of 37 per cent. on the excess of their cost over the ring-oiling type.

CENTRAL RAILWAY CLUB.

The regular monthly meeting of the Central Railway and Engineering Club was held at the Prince George Hotel, Toronto, Dec. 21. The business of the evening consisted of an address on "The Manufacture of Commercial Gas," by C. J. Herring, and the election of officers for the ensuing year. C. Jefferis, the retiring President, occupied the chair.

The following were elected officers for 1910: President, J. Duguid, general foreman G. T. R.; first vice-pres., G. Baldwin, general yardmaster Canada Foundry Co.; second vice-pres., J. Bannan, chief engineer, city hall, Toronto.

Executive Committee—Messrs C. A. Jefferis, W. R. McRae, O. A. Cole, A. M. Wickens, A. E. Till and A. Taylor, Toronto, and Mr. Patterson, Stratford.

PLAYING WITH FIRE.

A can of gasolene can be handled as safely as a can of oil, for liquid gasolene does not explode. It is the gasolene vapor that is highly explosive when properly mixed with air. The Scientific American recently published three illustrations showing the safety with which burning gasolene may be handled. One showed a man pouring burning gasolene from one can into another. In a second he was blowing into the spout of a can of gasolene to which a match had been applied. The little blue flame that ordinarily plays around the mouth of the can was transformed into a burning torch. The third showed a pool of burning gasolene on the floor, and two gasolene cans aflame, but there was no explosion.

There is all the difference in the world between an attempt to study by mere reading and a real study through the actual doing of work.—Prof. John Perry.

MISCELLANEOUS.

DOES YOUR FIRE INSURANCE POLICY protect you? There are points in connection with fire insurance policies that need expert handling to secure proper protection. We are fire insurance experts. We can safeguard your interests and procure the lowest rates. Mitchell & Ryerson, Confederation Life Building, Toronto. (11)

ERRORS AVOIDED—LABOR SAVED—Using the Shouperior Autographic Register. Three copies issued at one writing. 1st, invoice; 2nd, delivery ticket; 3rd, charge sheet, perforated for filing. No handling of carbons. High grade printing and neat invoices. Make full inquiry. Autographic Register Co., 191-193-195 Dorchester St. East, Montreal.

FOR SALE.—The right to manufacture and sell on royalty in the Province of Ontario, and also in the Western Provinces, a fire escape which has been proven to be the best and only complete fire escape in the world. The right man can make a fortune out of this proposition. For all information address, The Universal Fire Escape Co., No. 234 Dufferin St., Montreal, P.Q.

FIREPROOF Windows and Doors made strictly to the Fire Underwriters' requirements reduce your Insurance Rates and protect your building. We are experts in this line, and guarantee you really fireproof goods, and the maximum Insurance allowance. Let us give you our figure. A. B. Ormsby, Limited, Sheet Metal Workers. Factories, Toronto, Winnipeg.

PROBABLY the most talked about machine in Canada is the Hainer Book-keeping Machine. It combines in one machine the cash and credit register, time recorder and account register. Representatives wanted everywhere. Write for our proposition. Book-keeping Machines, Ltd., 424 Spadina Ave., Toronto.

YOU DON'T BUY a National Cash Register—it pays for itself. Saves money. Prevents mistakes. We can prove it. National Cash Register Co., 285 Yonge St., Toronto.

\$75 buys the best duplicating machine on the market. ACME will print anything a job-printer can do. Complete outfit; Acme Duplicating Machine; one tubular stand fitted with type cases; compartments plainly lettered and arranged like universal keyboard of the standard make of typewriters; one drawer for accessories and forms; 20 lb. font of typewriter type; one chase; one Acme ribbon any color with typewriter ribbon to match; one pair tweezers; two quills; one key; one oil can; and one set of reglets. Sold with a guarantee. Acme Duplicator Co., Baltimore, Md., U.S.A.

MISCELLANEOUS.

INSURE health by installing Pullman System of natural ventilation. Simple, inexpensive. Fresh air introduced under window sash, is gradually diffused throughout room. All foul air in room expelled through special outlets. Use in store, office and home. Send for free booklet. Wm. Stewart & Co., Saturday Night Bldg., Toronto; Board of Trade Bldg., Montreal.

MISCELLANEOUS.

KEEP ACCOUNTS WITHOUT BOOK-KEEPING. A century ago accounting meant keeping books; to-day you can keep accounts cheaper, better, quicker and more accurately by throwing away all books and installing a McCaskey Account Register. Don't be skeptical—Investigation costs nothing. Write us to-day. Dominion Register Company, Ltd., 100 Spadina Ave., Toronto.

BRASS CASTINGS
OF ALL SIZES AND KINDS
LUMEN BEARING COMPANY
BUFFALO TORONTO

The Art of Welding Metals

The use of the *Oxy-acetylene blow-pipe* in welding has greatly extended the field in this class of work.

Simple or complicated fractures and breaks in all kinds of machinery may be repaired and made almost equal to new in strength and appearance; the broken edges of iron, steel, aluminum and other metals are melted together with the addition of more metal under a temperature of 6,000 to 7,000 degrees Fahrenheit.

This plan is much superior to brazing or riveting and may be used for an infinite variety of new and repair work hitherto done by less efficient methods.

We have installed a plant for the purpose of welding by this process, and shall be glad to send particulars and quote prices.

Enquiries and correspondence solicited.

CHAS. POTTER,
85 YONGE ST., TORONTO

GREEN'S
"Emergency" Cupola

is a most excellent little melter, and has been extensively adopted both at home and abroad, including several Government departments.

For Melting from 1 to 10 cwt. of iron per hour.



Full Particulars on Application

We are also makers of **The Rapid "Economic" Cupola** and complete Foundry Melting Equipments.

FEED-WATER HEATERS, FILTERS, &c.

GEORGE GREEN & CO.
FOUNDRY ENGINEERS
KEIGHLEY, - ENGLAND

Cable Address: "CUPOLA," Keighley.

Special Subscription Offer With
The Financial Post

The pre-eminent financial and investment paper of Canada.

The Investor's Library:

The Investor's Primer	\$1.00
The Art of Wall Street Investing	1.00
Mining Investments and How to Judge Them	1.00
Pitfalls of Speculation	1.00
Cycles of Speculation	1.50
All with The Financial Post, one year	5.00
Any two with The Financial Post, one year	3.50

This offer applies to new subscribers or to old subscribers who send a new subscriber's name and the corresponding remittance.

FOR SAMPLE COPY ADDRESS

The Financial Post - Toronto

WE MANUFACTURE IN

CANADA

A Complete Line of

Cotton Buffs

For all uses
In all sizes
Of all grades

AT LOWEST
PRICES

F. L. & J. C. Codman

84 Sandwich St. West, - Windsor, Ont.

BOSTON,
MASS.

DETROIT,
MICH.

Power and Steam Pumps

Centrifugal Pumps, Paper Mill Pumps,
Rotary Pumps, Travelling Cranes, Etc.



The Smart-Turner Machine Co., Limited
HAMILTON, ONTARIO.

“CONQUEROR”

HIGH SPEED STEEL AND DRILLS

Made by

J. BEARDSHAW & SON, LTD., SHEFFIELD

ARE UNEQUALLED FOR DURABILITY AND UNIFORMITY.

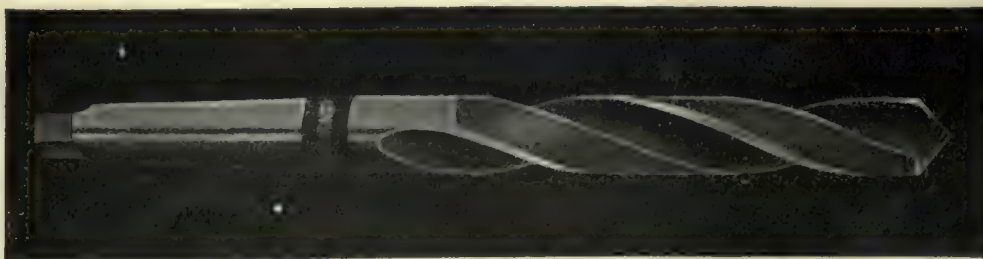

OUR IMPROVED

HIGH SPEED DRILL is much imitated, but not equalled either in quality or price.

SELLING AGENT:

Alexander Gibb, 13 St. John St., Montreal



"MORSE" CUTTERS



We, ourselves, are large users of Cutters of all kinds, so it stands to reason we make them of the best material and in the best manner known. We want the best that can be made and so do you. You run no risk in buying "MORSE" CUTTERS.

Our goods are handled by Rice Lewis & Son, Limited, Toronto. Aikenhead Hardware, Limited, Toronto. Frothingham & Workman, Montreal. Mechanics Supply Co., Quebec.

MORSE TWIST DRILL & MACHINE CO.,
NEW BEDFORD, MASS., U.S.A.

Geo. Anderson & Co., Ltd

157 Craig St. West,
MONTREAL
and CARNOUSTIE, SCOTLAND.

Makers all sizes of

Travelling Cranes
Electric Derricks
Steam Derricks
Locomotive Cranes

Send for Catalogue and Price



Photo of 5-ton Motor Travelling Crane, 60-foot span

BROWN & SHARPE MFG. CO., Providence, R.I., U.S.A.

They Successfully Withstand SEVERE SERVICE
That is why Shop Foremen Recommend

B. & S. CUTTERS

to the manufacturer, and, in turn, the reason why manufacturers specify them in their orders. The foreman's detailed knowledge of the uses and comparative merits of cutters is especially valuable and his recommendation of these cutters is conclusive proof of their worth.

Our cutter list, containing illustrations, dimensions and prices of the entire line, will be mailed to you free upon request.

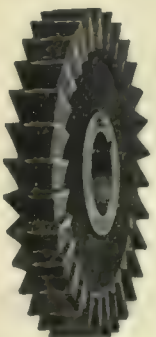

37 Styles
3600 Sizes



One
Quality



CANADIAN MACHINERY BUYERS' DIRECTORY

To Our Readers—Use this directory when seeking to buy any machinery or power equipment.

You will often get information that will save you money.

To Our Advertisers—Send in your name for insertion under the heading of the lines you make or sell.

To Non-Advertisers—A nominal rate of \$1 per line a year is charged non-advertisers.

Abrasive Materials.

Aikenhead Hardware, Ltd., Toronto
The Canadian Fairbanks Co., Montreal
Canadian Hart Wheels Ltd., Hamilton.
Carborundum Co., Niagara Falls, N.Y.
Stevens, F. B., Detroit, Mich.

Air Receivers.

Canadian Rand Co., Montreal.

Alloys.

Hermann Boker & Co., Montreal
Francis Hyde & Co., Montreal.

Aluminum.

Parke & Leith, Toronto

Anvils, Bench.

Aikenhead Hardware Ltd., Toronto
General Supply Co. of Canada, Ottawa.

Arbors.

The Canadian Fairbanks Co., Montreal
Cleveland Twist Drill Co., Cleveland
Morris Twist Drill and Machine Co., New Bedford
Jas. Smart Mfg. Co., Brockville, Ont.

Arbor Presses.

Niles-Bement-Pond Co., New York.

Automatic Machinery.

Gardner, Robt. & Son, Montreal
Kellogg & Co., Toronto
Mussens Limited, Montreal.

Axle Cutters.

Butterfield & Co., Rock Island, Que.
A. B. Jardine & Co., Hespeler, Ont.

Babbitt Metal.

Aikenhead Hardware, Ltd., Toronto
Canada Metal Co., Toronto.
The Canadian Fairbanks Co., Montreal
General Supply Co. of Canada
Lumen Bearing Co., Toronto.
Tallman Brass & Metal Co., Hamilton

Balls, Steel.

Hermann Boker & Co., Montreal

Barrels, Steel Shop.

Cleveland Wire Spring Co., Cleveland.

Barrels, Tumbling.

Calumet Engineering Works, Harvey, Ill.

Dominion Foundry Supply Co., Montreal
Hamilton Facing Mill Co., Hamilton.
Francis Hyde & Co., Montreal.
Northern Engineering Works, Detroit.
Sheldon's Limited, Galt.
The Smart-Turner Mach. Co., Hamilton.
Whiting Foundry Equipment Co., Harvey, Ill.

Bars, Boring.

Hall Engineering Works, Montreal.
Niles-Bement-Pond Co., New York.

Belting, Chain.

The Canadian Fairbanks Co., Montreal
Jeffrey Mfg. Co., Montreal
Jones & Gasse, Montreal
Waterous Engine Works Co., Brantford.

Belting, Cotton.

Dominion Belting Co., Hamilton.

Belting, Leather.

The Canadian Fairbanks Co., Montreal.
General Supply Co. of Canada, Ottawa
McLaren, J. O., Montreal.
Sadler & Haworth, Montreal

Bending Machinery.

John Bertram & Sons Co., Dundas, Ont.
Bliss, E. W., Co., Brooklyn, N.Y.
Kellogg & Co., Toronto
Jardine, A. B. & Co., Hespeler, Ont.
London Mach. Tool Co., Hamilton, Ont.
National Machinery Co., Tiffin, Ohio.
Niles-Bement-Pond Co., New York.

Blowers.

The Canadian Fairbanks Co., Montreal
Dominion Foundry Supply Co., Toronto
General Supply Co. of Canada, Ottawa.
Hamilton Facing Mill Co., Hamilton and Montreal.
Francis Hyde & Co., Montreal.

Monarch Eng. & Mfg. Co., Baltimore, Md
W. S. Rockwell Co., New York
Sheldon's Limited, Galt.

Blast Gauges—Cupola.

Dominion Foundry Supply Co., Toronto
Hamilton Facing Mill Co., Hamilton.
Francis Hyde & Co., Montreal.
Sheldon's Limited, Galt.

Boilers.

Canadian General & Shoe Machinery Co., Lewis, Que.
General Supply Co. of Canada, Ottawa
Goldie & McCulloch Co., Galt.
Mussens Limited, Montreal.
Owen Sound Iron Works Co., Owen Sound.
Robb Engineering Co., Amherst, N.S.
The Smart-Turner Mach. Co., Hamilton.
Standard Engineering Co., Toronto.
Waterous Engine Works Co., Brantford.

Boiler Compounds.

Aikenhead Hardware, Ltd., Toronto
Nichols Chemical Co., Montreal.
Hall Engineering Works, Montreal.

Boiler Feed Regulators.

Standard Engineering Co., Toronto.

Boiler Makers' Supplies.

Allen, John F. New York

Boiler Mountings.

Standard Engineering Co., Toronto.

Boiler Settings.

Harbison-Walker Refractories Co., Pittsburgh

Bolts and Nuts.

Harris Forge Co., New Glasgow, N.S.

Bolt and Nut Machinery.

John Bertram & Sons Co., Dundas, Ont.
Gardner, Robt. & Son, Montreal
General Supply Co. of Canada, Ottawa.
Kellogg & Co., Toronto
London Mach. Tool Co., Hamilton.
Mussens Limited, Montreal.
National Machinery Co., Tiffin, Ohio.
Niles-Bement-Pond Co., New York.
Waterbury Farrell Foundry & Machine Co., Waterbury, Conn.

Bolt Cutters.

Aikenhead Hardware, Ltd., Toronto
Kellogg & Co., Toronto
Mussens Limited, Montreal.

Boring Machines, Upright.

John Bertram & Sons Co., Dundas, Ont.
Kellogg & Co., Toronto
London Mach. Tool Co., Hamilton.
Mussens Limited, Montreal.
Niles-Bement-Pond Co., New York.

Boring Machines, Wood.

The Canadian Fairbanks Co., Montreal
Independent Pneumatic Tool Co., Chicago, Ill.
Kellogg & Co., Toronto
London Mach. Tool Co., Hamilton.
Mussens Limited, Montreal.
Jas. Smart Mfg. Co., Brockville, Ont.

Boring and Turning Mills.

John Bertram & Sons Co., Dundas, Ont.
Kell & Co., Toronto
London Mach. Tool Co., Hamilton.
Mussens Limited, Montreal.
Hamilton Facing Mill Co., Hamilton.
Niles-Bement-Pond Co., New York.
H. W. Petrie, Toronto.

Box Puller.

A. B. Jardine & Co., Hespeler, Ont.

Boxes, Steel Shop.

Cleveland Wire Spring Co., Cleveland.
Francis Hyde & Co., Montreal.

Boxes, Tote.

Cleveland Wire Spring Co., Cleveland.
Francis Hyde & Co., Montreal.

Brake Shoes

Montreal Steel Works, Montreal

Brass Melting Furnaces.

Hamilton Facing Mill Co., Hamilton.
Francis Hyde & Co., Montreal.
Monarch Eng. & Mfg. Co., Baltimore, Md.
Sheldon's Limited, Galt.
W. S. Rockwell Co., New York
Whiting Foundry Equipment Co., Harvey, Ill.

Brass Working Machinery.

Gardner, Robt. & Son, Montreal
Mussens Limited, Montreal.
Warner & Swasey Co., Cleveland, Ohio.

Brushes, Foundry and Core.

Dominion Foundry Supply Co., Toronto
Hamilton Facing Mill Co., Hamilton.
Francis Hyde & Co., Montreal.
Stevens, F. B., Detroit, Mich.

Buckets, Olam Shell.

Jeffrey Mfg. Co., Montreal
Whiting Foundry Equipment Company, Harvey, Ill.

Buckets, Crab.

Jeffrey Mfg. Co., Montreal

Buffing and Polishing Wheels

F. L. & J. C. Codman, Windsor, Ont.

Bulldozers.

John Bertram & Sons Co., Dundas, Ont.
General Supply Co. of Canada, Ottawa.
London Mach. Tool Co., Hamilton, Ont.
National Machinery Co., Tiffin, Ohio.
Niles-Bement-Pond Co., New York.

Burners, Core Oven.

Hamilton Facing Mill Co., Hamilton.
Francis Hyde & Co., Montreal.
Monarch Eng. & Mfg. Co., Baltimore, Md
W. S. Rockwell Co., New York

Burners, Fuel Oil.

Francis Hyde & Co., Montreal.
Monarch Eng. & Mfg. Co., Baltimore, Md
W. S. Rockwell Co., New York
Whiting Foundry Equipment Co., Harvey, Ill.

Burners, Natural Gas.

Monarch Eng. & Mfg. Co., Baltimore, Md
Francis Hyde & Co., Montreal.
W. S. Rockwell Co., New York

Burrs, Iron and Copper.

Parmenter & Bullock Co., Gananogue

Cables, Aerial and Under ground.

Aikenhead Hardware, Ltd., Toronto
Phillips, Eugene F., Electrical Works, Montreal.
Waterous Engine Works Co., Brantford.

Canners' Machinery.

Bliss, E. W., Co., Brooklyn, N.Y.
Jeffrey Mfg. Co., Montreal

Car Replacers

Montreal Steel Works, Montreal

Car Wheels, Mine

Montreal Steel Works, Montreal

Cars, Core Oven.

Calumet Engineering Works, Harvey, Ill.
Francis Hyde & Co., Montreal.
Whiting Foundry Equipment Co., Harvey, Ill.

Cars, Factory & Warehouse.

Francis Hyde & Co., Montreal.
Sheldon's Limited, Galt.
Whiting Foundry Equipment Co., Harvey, Ill.

Cars, Foundry.

Dominion Foundry Supply Co., Montreal
Hamilton Facing Mill Co., Hamilton.
Francis Hyde & Co., Montreal.
Monarch Eng. & Mfg. Co., Baltimore, Md.
Sheldon's Limited, Galt.
Whiting Foundry Equipment Co., Harvey, Ill.

Cars, Industrial.

The Canadian Fairbanks Co., Montreal
Francis Hyde & Co., Montreal.
Mussens Limited, Montreal.
Whiting Foundry Equipment Co., Harvey, Ill.

Castings, Aluminum.

Lumen Bearing Co., Toronto
Tallman Brass & Metal Co., Hamilton

Castings, Brass.

Wm Coulter & Sons, Toronto
Hall Engineering Works, Montreal.
Lumen Bearing Co., Toronto
Owen Sound Iron Works Co., Owen Sound.
Tallman Brass & Metal Co., Hamilton
Waterous Engine Works Co., Brantford

Castings, Grey Iron.

Gardner, Robt. & Son, Montreal
Hall Engineering Works, Montreal.
Katie Foundry Co., Galt, Ont.
Owen Sound Iron Works Co., Owen Sound.
Smart-Turner Machine Co., Hamilton.
Jas. Smart Mfg. Co., Brockville, Ont.
Waterous Engine Works Co., Brantford

Castings, Manganese Steel

Montreal Steel Works, Montreal

Castings, Phosphor Bronze.

Lumen Bearing Co., Toronto

Castings, Semi-Steel.

Montreal Steel Works, Montreal

Castings, Sewer.

Jas. Smart Mfg. Co., Brockville, Ont.

Cement Machinery.

The Canadian Fairbanks Co., Montreal
Gardner, Robt. & Son, Montreal
Jeffrey Mfg. Co., Montreal
Owen Sound Iron Works Co., Owen Sound
Waterous Engine Works Co., Brantford.

Centreing Machines.

John Bertram & Sons Co., Dundas, Ont.
Gardner, Robt. & Son, Montreal
Jeffrey Mfg. Co., Montreal
London Mach. Tool Co., Hamilton, Ont.
Niles-Bement-Pond Co., New York.
Pratt & Whitney Co., Hartford, Conn.

Centrifugal Pumps.

Pratt & Whitney Co., Hartford, Conn.
Waterous Engine Works Co., Brantford.

Chain Blocks.

Aikenhead Hardware, Ltd., Toronto
The Canadian Fairbanks Co., Montreal
General Supply Co. of Canada, Ottawa.
Mussens Limited, Montreal.

Charcoal.

Dominion Foundry Supply Co., Toronto
Hamilton Facing Mill Co., Hamilton.
Francis Hyde & Co., Montreal.
Stevens, F. B., Detroit, Mich.

Chemicals.

Nichols Chemical Co., Montreal

Chucks, Brass Finishers.

Aikenhead Hardware, Ltd., Toronto
Skinner Chuck Co., New Britain, Conn

Chucks, Combination.

Aikenhead Hardware, Ltd., Toronto
Skinner Chuck Co., New Britain, Conn

Chucks, Outting-off.

Skinner Chuck Co., New Britain, Conn

Chucks, Drill and Lathe.

Aikenhead Hardware, Ltd., Toronto
John Bertram & Sons Co., Dundas, Ont.
Cleveland Twist Drill Co., Cleveland
Cushman Chuck Co., Hartford, Conn
Gardner, Robt. & Son, Montreal
General Supply Co. of Canada, Ottawa
Ker & Goodwin, Brantford.
London Mach. Tool Co., Hamilton.
Morris Twist Drill and Machine Co., New Bedford
Mussens Limited, Montreal.
Niles-Bement-Pond Co., New York
Russell Anti-friction Drill Chuck Co.
Elmira, N.Y.
Skinner Chuck Co., New Britain, Conn
Standard Tool Co., Cleveland.

Chucks, Grinding Machine.

E Horton & Son Co., Windsor Locks, Conn.
Skinner Chuck Co., New Britain, Conn

Chucks, Independent Jaw.

Aikenhead Hardware, Ltd., Toronto
Skinner Chuck Co., New Britain, Conn

Chucks (Planer or Milling.)

Gardner, Robt. & Son, Montreal
Skinner Chuck Co, New Britain, Conn

Chucks, Screw Machine,

Skinner Chuck Co, New Britain, Conn

Chucking Machines.

Niles-Bement-Pond Co., New York.
Warner & Swasey Co., Cleveland, Ohio

Chucks, Universal.

Aikenhead Hardware, Ltd., Toronto
The Canadian Fairbanks Co., Montreal
Skinner Chuck Co, New Britain, Conn

Circuit Breakers.

Canadian Westinghouse Co., Hamilton.

Clamps.

Jas. Smart Mfg. Co., Brockville, Ont.

Clocks, Electric,

G. C. Bredin, London, Ont.

Clocks, Portable,

G. C. Bredin, London, Ont.

Clocks and Dials, Watchmen's,

G. C. Bredin, London, Ont.

Cloth and Wool Dryers.

B. Greening Wire Co., Hamilton.
Sheldons Limited, Galt

Coal Boring Machines.

Cumming, J. W., New Glasgow, N.S.

Coal Handling Machinery.

Jeffrey Mfg. Co., Montreal
Standard Engineering Co., Toronto.
Waterous Engine Works Co., Brantford

Coal Miners' Tools.

Aikenhead Hardware, Ltd., Toronto
Cumming, J. W., New Glasgow, N. S.

Collectors, Pneumatic.

Sheldons Limited, Galt

Combination Pliers.

Reed Mfg. Co., Erie, Pa.

Compressors, Air.

Canadian Rand Co., Montreal.
Canadian Westinghouse Co., Hamilton.
Da Ling Bros., Ltd., Montreal.
General Supply Co. of Canada, Ottawa.
Hall Engineering Works, Montreal, Que.
Independent Pneumatic Tool Co., Chicago.

Monarch Eng. & Mfg. Co., Baltimore, Md.
Mussens Limited, Montreal.
Niles-Bement-Pond Co., New York.
The Smart-Turner Mach. Co., Hamilton.

Concentrating Plant.

Gardner, Robt. & Son, Montreal

Concrete Mixers.

The Canadian Fairbanks Co., Montreal
Jeffrey Mfg. Co., Montreal

Condensers.

Goldie & McCulloch Co., Galt.
Hall Engineering Works, Montreal.
Smart-Turner Machine Co., Hamilton.
Waterous Engine Co., Brantford.

Consulting Engineers.

Bain & Mitchell, Montreal
Death & Watson, Toronto
Fensom, C. J., Toronto
Hall Engineering Works, Montreal.
Robertson J. M., Ltd., Montreal
T. Pringle & Son, Montreal.
Standard Engineering Co., Toronto.

Controllers and Starters

Electric Motor.

Canadian Westinghouse Co., Hamilton.
T. & H. Electric Co., Hamilton.

Conveyor Machinery.

The Canadian Fairbanks Co., Montreal
Goldie & McCulloch Co., Galt
Jeffrey Mfg. Co., Montreal
Mussens Limited, Montreal.
Smart-Turner Machine Co., Hamilton.
Waterous Engine Works Co., Brantford.

Coping Machines.

John Bertram & Sons Co., Dundas, Ont.
London Mach. Tool Co., Hamilton.
Niles-Bement-Pond Co., New York.

Corundum and Corundum Wheels.

Aikenhead Hardware, Ltd., Toronto
The Canadian Fairbanks Co., Montreal
Canadian Hart Wheels Ltd., Hamilton
General Supply Co. of Canada, Ottawa.

Core Box Machines.

Fox Machine Co., Grand Rapids.
Francis Hyde & Co., Montreal.

Core Cutting-off and Coning Machine.

Hamilton Facing Mill Co., Hamilton.
Francis Hyde & Co., Montreal.

Core Compounds.

Dominion Foundry Supply Co., Toronto
Hamilton Facing Mill Co., Hamilton.
Francis Hyde & Co., Montreal.
Stevens, F. B., Detroit, Mich.

Core-Making Machines.

Hamilton Facing Mill Co., Hamilton.
Francis Hyde & Co., Montreal.
Stevens, F. B., Detroit, Mich.

Core Ovens.

Calumet Eng. Works, Harvey, Ill.
Dominion Foundry Supply Co., Montreal
Hamilton Facing Mill Co., Hamilton & Montreal
Francis Hyde & Co., Montreal.
Stevens, F. B., Detroit, Mich.

Core Prints—Standard.

Hamilton Facing Mill Co., Hamilton.

Counterbores.

Cleveland Twist Drill Co., Cleveland.
Morse Twist Drill and Machine Co., New Bedford

Countersinks.

Cleveland Twist Drill Co., Cleveland

Couplings.

Gardner Robt. & Son, Montreal
Owen Sound Iron Works Co., Owen Sound

Couplings, Air.

Canadian Rand Co., Montreal.
Independent Pneumatic Tool Co., Chicago

Cranes, Electric and Hand Power.

Advance Machine Works, Walkerville,
Calumet Eng. Works, Harvey, Ill.
Canadian Rand Co., Montreal.
Dominion Foundry Supply Co., Montreal
Gardner, Robt. & Son, Montreal
Hamilton Facing Mill Co., Hamilton.
Francis Hyde & Co., Montreal.
Mussens Limited, Montreal.
Niles-Bement-Pond Co., New York.
Northern Engineering Works, Detroit
Owen Sound Iron Works Co., Owen Sound
Smart-Turner-Machine Co., Hamilton.
Whiting Foundry Equipment Co., Harvey, Ill.

Cranes, Hydraulic.

Calumet Eng. Works, Harvey, Ill.
Whiting Foundry Equipment Co., Harvey, Ill.

Crank Pin Turning Machine.

London Mach. Tool Co., Hamilton.
Niles-Bement-Pond Co., New York.

Crankshafts.

Harris Forge Co., New Glasgow, N.S.

Crossings, Diamond Rail

Montreal Steel Works, Montreal

Crucibles.

Bartley, Jonathan, Crucible Co., Trenton, N. J.
Dominion Foundry Supply Co., Montreal
Hamilton Facing Mill Co., Hamilton.
Francis Hyde & Co., Montreal.
Siedel, R. B., Inc., Philadelphia
Stevens, F. B., Detroit, Mich.

Crushers, Rock or Ore.

Jeffrey Mfg. Co., Montreal
Waterous Engine Works Co., Brantford.

Cupolas.

Advance Machine Works, Walkerville
Calumet Eng. Works, Harvey, Ill.
Dominion Foundry Supply Co., Montreal
George Green & Co., Keighley, Eng.
Hamilton Facing Mill Co., Hamilton.
Francis Hyde & Co., Montreal.
Northern Engineering Works, Detroit
Sheldons Limited, Galt.
Whiting Foundry Equipment Co., Harvey, Ill.

Cupola Blast Gauges.

Dominion Foundry Supply Co., Montreal
Hamilton Facing Mill Co., Hamilton.
Francis Hyde & Co., Montreal.
Sheldons Limited, Galt.

Cupola Blocks.

Dominion Foundry Supply Co., Toronto
Hamilton Facing Mill Co., Hamilton
Harbison-Walker Refractories Co., Pittsburg
Francis Hyde & Co., Montreal.
Northern Engineering Works, Detroit
Ontario Lime Association, Toronto

Cu, Old Blowers.

Dominion Foundry Supply Co., Toronto
Hamilton Facing Mill Co., Hamilton.

Francis Hyde & Co., Montreal.
Northern Engineering Works, Detroit
Sheldons Limited, Galt

Cupola Linings.

Hamilton Facing Mill Co., Hamilton.
Harbison-Walker Refractories Co., Pittsburg
Francis Hyde & Co., Montreal.
Stevens, F. B., Detroit, Mich.

Cupola Twyers.

Francis Hyde & Co., Montreal.
Knoeppel Co., Buffalo, N. Y.

Gas, Flue.

Independent Pneumatic Tool Co., Chicago, Ill.

Cutters, Gear.

Aikenhead Hardware, Ltd., Toronto

Cutters, Pipe.

Aikenhead Hardware, Ltd., Toronto
The Canadian Fairbanks Co., Montreal
General Supply Co. of Canada, Ottawa.
A. B. Jardine & Co., Hespeler, Ont.
Reed Mfg. Co., Erie, Pa.
Trimont Mfg. Co., Roxbury, Mass.

Cutter Grinder Attachment

Cincinnati Milling Machine Co., Cincinnati

Cutter Grinders.

Cincinnati Milling Machine Co., Cincinnati

Cutters, Milling.

The Canadian Fairbanks Co., Montreal
Cleveland Twist Drill Co., Cleveland
Hamilton Mach. Tool Co., Hamilton, Ont.
Morse Twist Drill and Machine Co., New Bedford
Mussens Limited, Montreal.
Pratt & Whitney Co., Hartford, Conn.
Standard Tool Co., Cleveland.

Cutting-off Machines.

Armstrong Bros. Tool Co., Chicago
John Bertram & Sons Co., Dundas, Ont.
London Mach. Tool Co., Hamilton.
Mussens Limited, Montreal.
J. W. Petrie, Toronto.
Pratt & Whitney Co., Hartford, Conn.

Cutting-off Tools.

Armstrong Bros. Tool Co., Chicago.
The Canadian Fairbanks Co., Montreal
London Mach. Tool Co., Hamilton.
H. W. Petrie, Toronto.
Pratt & Whitney, Hartford, Conn.
L. S. Starrett Co., Athol, Mass.

Damper Regulators.

The Canadian Fairbanks Co., Montreal
Darling Bros., Ltd., Montreal
Standard Engineering Co., Toronto.

Dies.

Aikenhead Hardware, Ltd., Toronto
Armstrong Bros., Toronto
Banfield, W. H. & Son, Toronto
Blies, E. W., Co., Brooklyn, N. Y.
Fisher, A. D. Co., Toronto
Gardner, Robt. & Son, Montreal
Morse Twist Drill and Machine Co., New Bedford

Reed Mfg. Co., Erie, Pa.
Scott, Ernest, Montreal.

Die Stocks.

Aikenhead Hardware Ltd., Toronto
Curtis & Curtis Co., Bridgeport, Conn.
Jardine, A. B., & Co., Hespeler, Ont.

Dies, Self-opening.

Geometric Tool Co., New Haven, Conn.
Wortman & Ward Co., London.

Dies, Opening.

W. H. Banfield & Sons, Toronto
Jardine, A. B. & Co., Hespeler, Ont.
Pratt & Whitney Co., Hartford, Conn.

Dies, Threading.

Aikenhead Hardware, Ltd., Toronto
General Supply Co. of Canada, Ottawa.
Jardine, A. B., & Co., Hespeler, Ont.

Draft, Mechanical.

W. H. Banfield & Sons, Toronto.
Butterfield & Co., Rock Island, Que.
A. B. Jardine & Co., Hespeler
Pratt & Whitney Co., Hartford, Conn.
Sheldons Limited, Galt.

Drilling Machines, Horizontal.

John Bertram & Sons Co., Dundas, Ont.
Kelllogg & Co., Toronto
London Mach. Tool Co., Hamilton.
J. J. McCabe, N.-W. York City, N. Y.
Mussens Limited, Montreal
Niles-Bement-Pond Co., New York.

Drilling Machines, Locomotive.

John Bertram & Sons Co., Dundas, Ont.
Kelllogg & Co., Toronto
London Mach. Tool Co., Hamilton, Ont.
The Canadian Fairbanks Co., Montreal.
A. B. Jardine & Co., Hespeler, Ont.
Mussens Limited, Montreal.
Niles-Bement-Pond Co., New York.
H. W. Petrie, Toronto.

Drilling Machines, Multiple Spindle.

John Bertram & Sons Co., Dundas, Ont.
Kelllogg & Co., Toronto
London Mach. Tool Co., Hamilton, Ont.
Mussens Limited, Montreal.
Niles-Bement-Pond Co., New York.
H. W. Petrie, Toronto.

Drilling Machines, Radial.

The Canadian Fairbanks Co., Montreal
Kelllogg & Co., Toronto
London Mach. Tool Co., Hamilton.
Mussens Limited, Montreal.
Niles-Bement-Pond Co., New York.

Drilling Machines, Turret.

John Bertram & Sons Co., Dundas, Ont.
London Mach. Tool Co., Hamilton.
Niles-Bement-Pond Co., New York.

Drilling Machines, Upright.

Bawden Machine & Tool Co., Toronto.
John Bertram & Sons Co., Dundas, Ont.
Fox Machine Co., Grand Rapids
A. B. Jardine & Co., Hespeler, Ont.
Kelllogg & Co., Toronto
London Mach. Tool Co., Hamilton.
J. J. McCabe, New York City, N. Y.
Mussens Limited, Montreal.
R. McDougall Co., Galt

Drills, Bench.

General Supply Co. of Canada, Ottawa
Kelllogg & Co., Toronto
London Mach. Tool Co., Hamilton.
Pratt & Whitney Co., Hartford, Conn.

Drills, Bit Stock.

Cleveland Twist Drill Co., Cleveland
Morse Twist Drill and Machine Co., New Bedford

Drills, Blacksmith.

Aikenhead Hardware, Ltd., Toronto
Cleveland Twist Drill Co., Cleveland
A. B. Jardine & Co., Hespeler, Ont.
Kelllogg & Co., Toronto
London Mach. Tool Co., Hamilton.
Morse Twist Drill and Machine Co., New Bedford

Jas. Smart Mfg. Co., Brockville, Ont.
Standard Tool Co., Cleveland.

Drills, Centre.

Aikenhead Hardware, Ltd., Toronto
Cleveland Twist Drill Co., Cleveland
Morse Twist Drill and Machine Co., New Bedford
Pratt & Whitney Co., Hartford, Conn.
Standard Tool Co., Cleveland, O.
L. S. Starrett Co., Athol, Mass.

Drills, Coal and Plaster.

Cumming, J. W., New Glasgow, N.S.

Drills, Electric.

Cincinnati Electrical Tool Co., Cincinnati
Mussens Limited, Montreal.
Niles-Bement-Pond Co., New York.

Drills, High Speed.

Aikenhead Hardware, Ltd., Toronto
Herman Bokor & Co., Montreal
The Canadian Fairbanks Co., Montreal
Cleveland Twist Drill Co., Cleveland
Alexander Gibb, Montreal
J. J. McCabe, New York City, N. Y.
Morse Twist Drill and Machine Co., New Bedford
Mussens Limited, Montreal.
Pratt & Whitney Co., Hartford, Conn.
Standard Tool Co., Cleveland, O.

Drills, Hand.

A. B. Jardine & Co., Hespeler, Ont.

Drills, Oil Tube.

Cleveland Twist Drill Co., Cleveland
Morse Twist Drill and Machine Co., New Bedford

Drills, Pneumatic.

Allen, John F., New York
Canadian Rand Co., Montreal
Independent Pneumatic Tool Co., Chicago, New York
Mussens Limited, Montreal.
Niles-Bement-Pond Co., New York.

Drills, Portable Electric.

Cincinnati Electrical Tool Co., Cincinnati
United States Electrical Tool Co., Cincinnati.

Drills, Ratchet.

Aikenhead Hardware, Ltd., Toronto
Armstrong Bros. Tool Co., Chicago.
The Canadian Fairbanks Co., Montreal
Cleveland Twist Drill Co., Cleveland
General Supply Co. of Canada, Ottawa.
A. B. Jardine & Co., Hespeler
Morse Twist Drill and Machine Co., New Bedford
Pratt & Whitney Co., Hartford, Conn.
Standard Tool Co., Cleveland.

Drills, Rock.

Canadian Rand Drill Co., Montreal.
Jeffrey Mfg. Co., Montreal.

First Aid to Injured on a Great Canadian Railroad

The System Used in the Angus Shops, Montreal, Giving Full Information as to the Carrying Out of the Scheme on the C.P.R., with Illustrations.

By S. A. GIDLOW

One of the most popular movements on the Canadian Pacific Railway, of recent organization, is that of First Aid to the Injured, as carried on under the auspices of the St. John Ambulance Association.

First of all, in order that the reader may understand the importance and value of first aid both to employer and employe it may be well to give a brief outline showing what "First Aid" really is; what its objects are and the results of proper and improper first aid treatment, and I think the question, "What is first aid?" is best answered by stating what its objects are.

1st. To teach all people, outside of the medical profession, to render assistance to any person suffering accident or sudden illness until the arrival of the doctor.

2nd. To teach people what not to do in case of accident, so that there shall be no likelihood of a sympathetic but ignorant public causing unnecessary pain and suffering through improper treatment.

3. That in case of emergency, that is, bleeding, poisoning, choking or drowning, a life may not be sacrificed for the want of a little elementary knowledge on the part of the bystander.

The following particulars of an accident which occurred some little time ago show what terrible harm can be done by improper first aid treatment:

"A man was knocked down by a street car causing a simple fracture of the left thigh bone, that is to say, the bone only was broken and none of the parts adjacent thereto,

such as the tissues or artery, were injured or cut. The onlookers, with the idea of getting the poor fellow out of the way of passing traffic, lifted the man to a perpendicular position with the weight of his body on the broken leg, thereby causing



Fig. 1.—S. A. Gidlow, General Secretary.

the broken bones to become further displaced and to pierce the femoral or main artery of the thigh. As a result of this well meant action on the part of the public the man died from loss of blood in a few minutes.

He was killed by a well meaning but ignorant public. Had the driver or conductor in charge of the street car in question been instructed in the elementary principles of first aid, and made use of such knowledge, the man would no doubt have been alive to-day, and the street car company saved heavy claims for damages.

Compare the above with an accident which occurred in a machine shop recently, and where proper first aid was rendered as below:

"A man was caught by machinery and had his arm so lacerated that all the muscles were torn off and the brachial (arm) artery severed. He would have died of hemorrhage in a few minutes had it not been for the valuable aid afforded by a member of a First Aid Corps, who caught up the artery and controlled the bleeding by digital pressure until a tourniquet was procured, which he placed in position. The man was then removed to the hospital, where the arm had to be amputated at the shoulder. The assistance rendered by the first aid man was highly spoken of by the medical officer of the hospital, as there was no doubt it saved the other man's life."

These are only two of hundreds of cases where life has been lost, or, on the other hand, saved, depending on the ability of the bystander to render proper or improper treatment just when the accident occurred.

One can readily see from the instances given above what incalculable benefit



Fig. 2.—A First Aid Class at the Angus Shops.

first aid is to the railroad employe and the public generally.

The Need of Instruction.

The success of present day surgery is, in a great measure, due to the attention given to simple details in the preparation of the case prior to operation. Now, if preliminary care means successful operation, why should it not have

have, for some time past, realized the value of this movement to their employes and to themselves, as is seen from the fact that they have a large and complete organization at their works in Montreal, both in the car and locomotive departments, and now every shop has its quota of ambulance men, so that no matter in what part of the works an accident may happen these you

skeleton, bones, joints, and the muscular system.

C. Signs, symptoms and treatment of fractures, dislocations sprains and strains.

D. The triangular bandage and its application.

Second Lecture.

A. The heart and blood vessels. The circulation of the blood.

B. The general direction of the main arteries indicating the points where the circulation may be arrested by digital pressure or by the application of the tourniquet, or by other means.

C. The difference between arterial, venous and capillary bleeding, and the various extemporaneous means of arresting it.

D. The triangular bandage and its application.

The Third Lecture.

A. A brief description of the nervous system.

B. First aid to persons suffering from shock or collapse after injury, injury to the brain, collapse from drink, epilepsy, fainting, hysteria, sunstroke, electric shock, effects of lightning, and convulsions in children.

C. First aid in cases of frost bite, burns or scalds, injury by vitriol throwing, wounds, bites of animals, stings of insects.

D. What to do when the dress catches fire.

E. The triangular bandage and its application.

Fourth Lecture.

A. A brief description of the organs and mechanism of respiration.

B. The immediate treatment of the apparently drowned, or otherwise suffocated. Artificial respiration, treatment for choking.



Fig. 3.—A First Aid Class Composed of Lady Clerks at Angus, the General Secretary, Secretary for Montreal District C.P.R. and a Boy Patient.

every consideration in the treatment of accidents constantly happening in all our works and on the streets?

If an ambulance man, by reason of his ability to render immediate attention, can sustain life until such time as medical assistance can be obtained, surely he is rendering great service, not only to the medical profession but to the person who suffers accident, also to the firm for whom he may be working and whose employe he is aiding. The needless suffering caused by the ignorance of unskilled persons is as undoubted as it is deplorable. By rough handling, or for want of the slight knowledge necessary to enable one to support an injured limb, very serious consequences may ensue. To arrest bleeding from an artery is quite easy, yet thousands of lives have been lost in the presence of helpless spectators who had not been taught that little knowledge necessary to enable them to give intelligent first aid to the sufferer.

Accidents are of daily occurrence in all large works, yet, how many of their employes are capable of rendering first aid pending the arrival of the doctor.

All the great railroads in the Colonies (outside of the Dominion) have had many thousands of their employes instructed in First Aid to the Injured, which goes to show that it pays, aside from the humanitarian standpoint, to have men around our works who can give immediate assistance in case of accident or sudden illness.

The Canadian Pacific Railway Centre of the St. John Ambulance Association,

will find an ambulance man, ready and willing to give immediate help.

The cost of instruction, and the books and first aid material necessary, are furnished by the management free of charge. A lecturer is provided who gives one lecture per week to the men until the full course of five lectures has been given.

The syllabus of instruction is as follows:

First Lecture.

A. Preliminary remarks, objects of instruction, etc.

B. A brief description of the human



Fig. 4.—Ambulance Instructors. Back Row (Left to Right)—T. Pattison, Instructor; T. Pemberton, Instructor. Front Row (Left to Right)—W. Reid, District Secretary; S. A. Gidlow, General Secretary; J. H. Britton, Instructor.

C. First aid to those poisoned.

D. The immediate first aid treatment of injuries to the internal organs, and to those suffering from internal hemorrhage.

E. Foreign bodies in the eye, ear and nose.

Fifth Lecture (for Males Only).

A. Improvised methods of lifting and carrying the sick or injured.

carrying the injured on stretchers, etc. The reader may not think the placing of a man on a stretcher of much importance, but it is really a very important part of the work, as a great deal of damage may be done in placing a man on a stretcher.

Before the instructor allows his class to go up for final examination they are expected to answer a series of test ques-

3. What is the history of a case?
4. What is a fracture?
5. How many kinds of fracture are there?
6. Name the different fractures.
7. What color is arterial blood?
8. What color is venous blood?
9. Where is the brachial artery, etc.?
10. Where are the carpus bones, etc.?

Second Test.

1. What are the signs and symptoms of fracture?
2. How would you treat simple fracture?
3. What is the first thing to do in treating complicated fracture?
4. How would you distinguish fracture of the lower jaw?
5. What are the signs of dislocation?
6. How would you treat a dislocation?
7. What are the signs and treatment of fracture of the ribs?
8. What are varicose veins and how would you treat them?
9. What are the signs and treatment for internal hemorrhage?
10. What are the general rules for treatment of insensibility, etc.?

Third Test (Practical).

1. Treat this man for compound fracture of the left humerus.
2. Treat this man for hemorrhage from the left palmar arch.
3. Man is found lying on left side with knees and hips bent. There is free spurting bleeding from wound in right palm; besides the above injuries there are evidences of a ruptured spinal cord due to a fall of heavy rubbish on the patient's back. Place on stretcher, march home and put to bed.
4. This man is suffering from electric shock and wound on forehead. Place on



Fig. 5.—Treating a Broken Leg.

B. Methods of lifting and carrying the sick or injured on stretchers.

C. The conveyance of such by rail or in country carts.

As soon as ever the lectures are finished the men are then taken in hand by one of the company's ambulance instructors. No man is allowed to give instruction in the practical work before he is himself fully qualified, and before any such man is fully qualified to act as instructor he must hold the certificate, voucher and medallion of the St. John Ambulance Association, and these honors can only be obtained after three years, at least, constant application to first aid work, during which time he must attend three courses of lectures and undergo three examinations in first aid, each examination more exacting and more difficult to pass than the previous one before he obtains the coveted medallion or full qualifying badge of the Association, and one year must elapse between each first aid examination, so that it is impossible to obtain the medallion under three years.

The class then, as I said before, is taken in hand by one of the Company's instructors, whose duty it is to teach the practical work, such as the proper application of bandages and splints to various parts of the body and lifting and

tions and to do the practical work in connection with them.

Below are a few of the questions taken from each test paper as given prior to the last examination at the Angus Works in Montreal:

First Test.

1. What is first aid to the injured?
2. What are signs and symptoms?



Fig. 6.—First Aid Work.

stretcher, march to a given point and unload.

5. A man repairing an electric cable receives a shock which causes him to lose his hold and fall from the top of the pole to the ground. He receives a compound fracture of the right leg with severe hemorrhage, fractured ribs and

Work of First Aid.

One thing strictly impressed on all ambulance men is, the exact relative position first aid has to the medical profession. The ambulance man is given to clearly understand that he is not expected, or in a position, to supplant the doctor, or to treat any

made out, that proper and efficient first aid is rendered, as it is also a check on the material used.

A record is kept showing the value of each 'First Aider's' services to the company after he has qualified for the certificate of the association.

As an incentive to employees to obtain the certificate, the management grant certain privileges. For instance, other things being equal, the man holding a first aid certificate has preference of employment, preference for promotion and also granted an extra pass over and above the usual annual pass and on the same conditions.

Value of the Classes.

Of course, however much to be desired, it is scarcely to be expected that everyone should have the time or the inclination to join such organized bodies of "First Aiders" as the St. John Ambulance Association or the St. John Ambulance Brigade, but certainly every person should devote the time to attend at least one course of lectures, because,



Fig. 7.—Practical Work in First Aid at Angus Shops.

collar bone on left side. Treat him, place on stretcher, carry home and put to bed.

6. This man has broken his right thigh, you have only one splint. How would you treat him, etc.?

As soon as the instructor considers the class ready for examination he makes his report to the proper quarter and a medical officer of the Canadian centre of the St. John Ambulance Association is appointed to examine the class as, for obvious reasons, no lecturer is allowed to examine his own class. After the examination the men are given one hour per week in which to meet together for practice, and are by this means kept up to a proper state of efficiency, also, at stated intervals the men are inspected by a medical officer appointed by the management so that the company can find out for themselves if their men are up to the mark and able to do the work required of them.

accident to its final solution, for the simple reason, the work of the ambulance man ends where the doctor's commences, that is to say, the duty of the ambulance man is to prevent personal injury being made worse by the ignorant but sympathetic attention of his colleagues or fellow workmen. He would, if necessary, apply splints and bandages, administer simple remedies, place the sufferer in the most safe and comfortable position, and await the arrival of the doctor. In a less serious case he would give such treatment as was necessary and convey or send his patient to the doctor, and there his responsibility ends.

Every accident attended by an ambulance man is reported on a form specially provided for the purpose so that the management can see for themselves, by the manner in which the form is

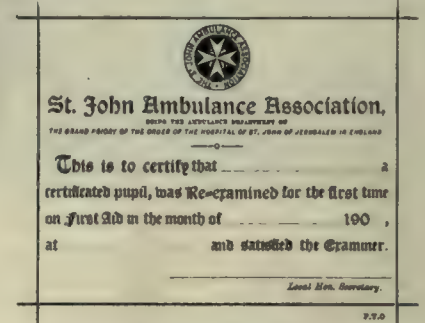

Fig. 10.—Voucher Given to Men Passing Second Examination.

from the poorest laborer to the president, we are all liable to accident and all are dependent on the same first aid principles, so that it is easy to realize the risk we run, one and all, every day of our lives by reason of the general ignorance which prevails of the merest

Ambulance man's report in Connection with accident at the Angus Locomotive Shops.

Name of person injured

Description of injury

How accident was treated

Material used

Signature

Ambulance man.

Supt. Loco Shops.

Note:—The above is to be filled in by the ambulance man who renders "First Aid" and sent to the Office of the Supt. of Angus Loco Shops as soon as possible after the accident.

Fig. 8.—Form to be Sent in by Ambulance Man After Attending Personal Injury.

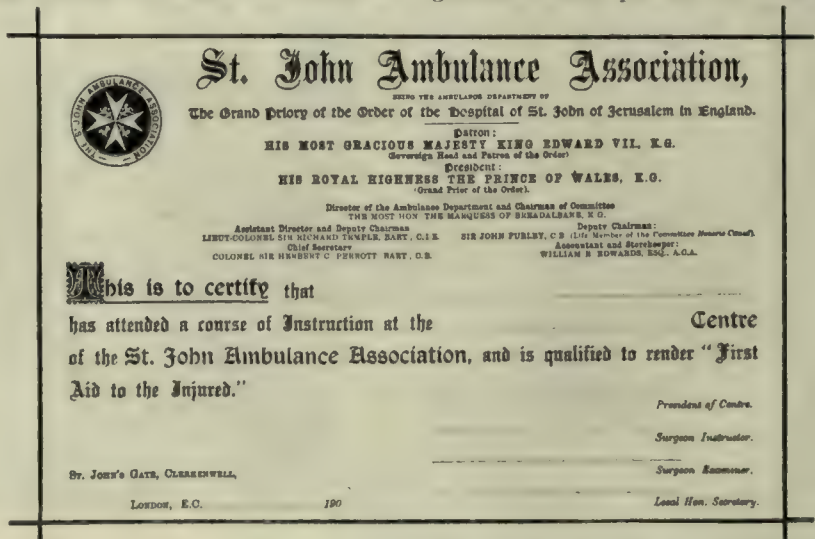

Fig. 9.—First Aid Certificate Issued by Head Office to Men Who Pass the Examinations.

rudiments of first aid treatment. As stated previously, every person should attend, at least, one course of first aid lectures, and then we should remove forever those old time notions which are so hard to kill:

1st. Children after sustaining a severe blow on the head through a fall, being kept awake by their mothers for fear they should die if allowed to sleep.

2nd. Kind people forcing neat brandy down the throat of an unconscious person.



Fig. 11.—Medallion Given to Those Who, After Three Years' Work, Pass the Third Examination.

3rd. Kind people rushing about madly, and then carrying an unfortunate sufferer to the nearest doctor or hospital or else putting the patient hurriedly into a hack without any regard to the nature of the injuries sustained.

4th. Kind people picking up a person who has had his leg run over by a passing vehicle, and trying to see if he can walk, or else dragging or lifting him out of the road to the pavement apparently with the idea of making the sufferer feel more comfortable, by placing him out of the way of the vehicular traffic.

5th. Kind people standing helpless by a friend or one of their own family seeing the life blood ebbing away.

Every medical man could, from his own experience give instances where the want of a little knowledge has led to increased suffering and subsequent harm to the injured person, and even to unnecessary loss of life. Now if there is one fact more recognized than another by medical men, it is this, viz., that the

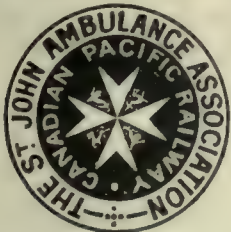

Fig. 12.—C.P.R. Ambulance Badge Worn by Men Qualified to Render First Aid.

immediate treatment adopted in the case of any severely injured person has a positive influence, and a most important

bearing upon the progress of the case. The first aid treatment is given in that interval which intervenes between the occurrence of the accident and the arrival of the medical man; that anxious and trying moment (which most of us know so well) before the patient can be taken to the doctor or the doctor brought to the patient, when we feel that something should be done, and when that something is the right thing done, by one not only qualified, but who is acting under the teaching of the medical man who will subsequently attend the case, it not only aids the speedy recovery of the unfortunate person, but brings a great sense of relief to those looking on.

Officers of Angus Shops Association.

Patrons—The Right Hon. Lord Strathcona and Mount Royal, K.C.M.G.; Sir Thomas Shaughnessy, K.C.V.O.; R. B. Angus, Esq.

President—D. McNicoll, Esq.

Vice-Presidents—J. W. Leonard, Esq.; H. H. Vaughan, Esq.; G. P. Girdwood, Esq., M.D., M.R.C.S., Eng.

Chairman—Major Laeey R. Johnson, C.A.

General Secretary—S. A. Gidlow, Esq.

COACH WHEEL LATHE TEST.

A large party of railway and machinery men visited the London Machine Tool Co., Hamilton, to witness a test on a 42 inch coach wheel lathe, on Jan. 24. This machine is driven by a 40 h.p. motor, two 6 h.p. motors driving the tailstocks. During the roughing operation a speed of 22 ft. per minute was maintained.

The party visited the Berlin Machine Works, manufacturers of wood-working machinery. They were then entertained at luncheon at the Hamilton Club. In the afternoon the party visited the Canadian Westinghouse and the Hamilton Steel & Iron plants.

Among the visitors were R. Patterson, G.T.R., Stratford; Thos. Treleven, J. H. Phillips, G.T.R., London; Wm. Pitts, G.T.R., W. Petersen, C.P.R., H. Marengo, C.P.R., Montreal; W. Flynn, M.C.R., St. Thomas; C. M. Murray of Chapman Double Ball Bearing Co., M. R. Ferguson of Crucible Steel Co. (expert dept.), A. E. Juhler, G. C. Keith, editor Canadian Machinery, Toronto; W. J. Press of Mussels, C. M. Rudel of Rudel-Yeates Co., A. E. Tyler, Crucible Steel Co., Montreal; Mr. Usher, Mr. Adams and J. Christopher of T. H. & B., W. K. Pearce of Dominion Bank, W. Currie of Hamilton Steel & Iron; G. W. Robinson and D. Ryan of Berlin Machine Works; C. H. Pook and B. Elshoff of Canadian Westinghouse, Hamilton.

INTERNATIONAL STEEL CO.

A company has been incorporated under the Ontario Companies Act to manufacture high-grade steel, such as is used in making edge tools, for planes, lathes, drills, cutlery, etc., and for dental and surgical instruments, which require a very fine high-grade material. The company is known as the International Tool Steel Co., capitalized at \$750,000, with its head office in the Traders Bank Bldg., Toronto. The directors of the company are John J. Main, who is vice-president and general manager of the Polson Iron Works; J. E. Murphy, lumberman; A. F. MacLaren, ex-M.P., who is also director of the Trusts and Guarantee Co., Manson Campbell, Chatham, president of the Chatham Waggon Co., and the Manson Campbell Co., and W. J. Chapman, Toronto.

The company has secured 351 acres of magnetic iron oxide sands in Quebec. It is intended to locate this plant in Welland, the ores being transported by boat.

The furnace to be used is of special design used in batteries of ten, each furnace being capable of producing 400 lbs. in ten hours. The furnace includes a combined reduction and crucible furnace with an 8-inch melting zone. It is intended that these furnaces should furnish power for forge hammers, rolls, etc.

SOCIETY NEWS.

The regular monthly meeting of the Central Railway and Engineering Club, Toronto, was held on Jan. 18, with J. Duguid in the chair. J. Bannon, chief engineer, Toronto City Hall, read a paper on Thermostats and Mechanical Regulations of Heat. A feature of the evening was the presentation of a past-president's jewel to C. A. Jeffries. Friday, February 25 will be a social evening.

On January 19, the S.P.S. Engineering Society, Toronto, entertained members of the Canadian Manufacturers' Association at their twenty-first annual banquet. About 1,000 were in attendance, Louis Simpson, Ottawa, referring to electric smelting, reviewed the work of producing iron from ores and pointed out the value to Canada of this method of reduction.

Robert W. Angus, Professor of Mechanical Engineering, gave a lecture on Turbine Pumps, before the Engineers' Club, Toronto, on January 20. The lecture, which was given in the New University Hydraulic Laboratory, was illustrated by numerous lantern slides.

A Neglected Factor in Canada's Industrial Life

The Giving of Fellowships by Manufacturers to Stimulate Research Work will Assist Investigations of Principles Underlying Specific Industries in the Interests of which they are Working.

In an address delivered to the members of the Canadian Manufacturers' Association on April 25th, 1901, by Professor W. R. Lang, of the University of Toronto, on the subject of chemistry and its relation to the arts and manufactures of the country, he said:

"In discussing a subject such as you have asked me to bring before you to-night, it is only possible for me to take up the matter in a general way, more with reference to the industries of Canada, and, at the same time, to consider how best these industries may be benefited and developed by the application to them of sound, general and scientific training. Chemistry may be defined as the science which deals with the composition of matter, and, as all industries of whatever nature involve chemical processes of one kind or another, it may safely be said that no industry can succeed without chemistry."

In closing, the lecturer added:

If the various companies were to combine to establish a research laboratory, they would have to place themselves and the problems entirely in the hands of the chemist whom they appointed chief, and who might or might not be capable of bringing their research to a practical issue. Is this not a case in which it is better to invite chemists at large to take up the research? Are the chances of finding the right man for the work not enormously greater in this way than they would be in any other system of selection?

In order to carry out this idea, then, let me suggest that when difficulties occur recourse be had to those whose special training and circumstances permit of careful investigation of the subject. Where no secrecy is required and the services of the professional man consequently not called for, why not offer a prize for the satisfactory solution of the problem? At our universities there is always a sprinkling of graduates carrying on original research and who would be glad of the additional financial incentive to exercise their ingenuity and skill in clearing up the difficulty. At the same time they would be benefiting the manufacturer and indirectly the country while improving their own qualifications for an appointment in a sphere of future usefulness.

During the nine years that has elapsed since the above suggestion was thrown out practically no response has come from the manufacturers of Canada; but our neighbors to the south have acted on similar advice given by another University of Toronto man, Professor R. Kennedy Duncan of the University of Kansas, and two years ago various firms instituted fellowships in the chemical department of that University, varying in value from \$500 to \$1,500 per annum.

The successful candidates for these fellowships, who are all university graduates that have specialized in chemistry, hold their appointment for two years and devote themselves entirely to the

study and investigation of the principles underlying the specific industry in the interests of which they are working.

Subjects Treated.

Some idea of the nature of these industries may be gathered from the following list of subjects, whose importance in the manufacturing world has prompted liberal subscriptions for the elucidation of the many problems met with in the factory:—Cements, casein, bread, laundry work, enamels, diatase, the preservation of wood, borax, boracic acid, glass—the relation between its physical properties and its chemical composition.

Each fellow must, of course, familiarize himself with the present conditions of his particular industry. He is informed as to the direction in which possible improvements may lie, and must make himself master of the rationale of each process. Then he tackles the real problems, with the knowledge of methods of investigation that his college training has given him, aided by such advice as the head of the laboratory can give him, and anything he may discover, improve on or invent he conveys to the firm whose fellowship he holds.

Professor Duncan has seen, also, that the interests of the investigation are not neglected, and the receipt of a percentage of the profits from any invention or improvement encourages the fellow to further efforts.

So far, the scheme has been highly successful, and it is safe to say that the chemist who devotes two years of his time to investigation of some industry, with the facilities that a university laboratory gives, must become a valuable asset to the firm paying the scholarship, and is more than likely to be given a responsible position in the firm's works.

To the writer's knowledge, one firm already has benefited largely from the work done by its fellow, and an almost new class of scientific manufacturers bids fair to result from the institution of these industrial fellowships.

Would it not be well for some of our Canadian manufacturers to seriously consider a similar line of action—worked out with the assistance of the heads of the chemistry department of our own universities?

SILICON AND MAGNETIC PROPERTIES.

In the *Rundschau für Technologie* Kolben states that pure silicon has a very high electrical resistance in comparison with metals, and approximates in this respect closely to carbon. A further point of similarity is found in the effect of warmth on the resistance, both temperature co-efficients being negative, whilst those of all metals are positive. The thermoelectric force between pure silicon and antimony is more than thrice as great as that between bismuth and antimony. The electrical resistance of iron is heightened by an addition of silicon, the maximum increase being attained in presence of 4 per cent. of silicon. At the same time, this alloy exhibits the valuable property that the resistance is practically independent on temperature, so that the alloy is excellently adapted for the construction of resistances. As regards the question of magnetic losses, so important in the construction of transformers, iron with about 3.5 per cent. of silicon gives about the same loss by hysteresis as slightly silicified iron; but the losses by vortical currents are far smaller, owing to the high electrical resistance.

LECTURES ON GRINDING.

Those interested in the subject of grinding, and living in Montreal and Toronto, will be given an opportunity of hearing two experts on this subject at the following places:—

Technical High School, Montreal, February 8th; Engineering Building, McGill University, Montreal, on Feb. 9th and 10th; at University of Toronto on Feb. 11th.

The lecturers will be C. H. Norton, of the Norton Grinding Co., and E. W. Dodge, of the Norton Co., both of Worcester, Mass.

Mr. Norton will talk on "Cylindrical Grinding," and as there is probably no man on this continent better posted on this subject, this will undoubtedly be a most interesting talk.

Mr. Norton will explain the manufacture and uses of grinding wheels; the origin and process of manufacture of the abrasive materials and various styles of machines.

These talks will be illustrated by upwards of one hundred lantern slides and cover the subject thoroughly.

The Design of Bevel Gears with Shafts at Right Angles

The Design and Manufacture of Gears, whether Spur, Bevel or Spiral, Giving Information and Tables of Great Use to Mechanical Men.

By G. D. MILLS.

In this article and the one to follow, it is the intention to introduce a method for the calculation of all bevel gears, mitre gears, bevel gears with shafts at right angles, and bevel gears with shafts at acute and obtuse angles. In part I. I shall deal with shafts at right angles, and will introduce first a table of tooth formulae, the careful

In the right hand corner of Fig. 2 will be found a small right triangle, which has for its hypotenuse the addendum and its corner angle is equal to the centre angle, or angle of edge. The base of this triangle is the distance which must be added to the pitch diameter on each side of the gear, in order to determine the diameter of blank, and from which is derived the formulae O_1 and O_2 .

Fig 2 contains all the angles and dimensions which are necessary to properly prepare the blanks, and cut the teeth of bevel gears. If a pair of bevel gears are both of the same size they are said to be mitre gears; and the calculations of one serve for both, since the speed of the shaft is neither increased nor decreased, but simply transmitted at right angles. If, however, it is necessary to increase or decrease the speed in one of the wheels, it is evident the gears will have unequal dimensions and both wheels must be calculated. Before going into the actual operation of calculating, I shall enter into a brief explanation of the angles, etc., in Fig. 2 and the purpose they serve.

The angle included between the centre line of shaft, and a line drawn through the centre of the working depth of tooth, is the centre angle, and being first in importance its tangent may be readily determined by dividing the half pitch diameter of one gear, by the half pitch diameter of its mate, when shafts are at right angles. In the formulae which follow, however, I have substituted the number of teeth since they bear equal proportions to the pitch diameters, thus securing round numbers in calculating.

to the angle of edge, all three being found with one operation.

The angle increment or angle of the addendum is next to be determined. Its tangent could be found by dividing the addendum by length of centre line of teeth, which length is first found by dividing the half pitch diameter of wheel by sine of centre angle. However, a shorter method is to be had in the formula tangent $A = \frac{1}{2} N_2$ which gives the

same result. These two angles, the centre angle and the angle increment are the only angles which require calculation in bevel gears with shafts at right angles, as all the other angles are readily determined from them.

The cutting angle of gear is found by deducting the angle increment from the centre angle of gear, and the cutting angle of gear is the angle of blank of pinion, while the cutting angle of pinion is the angle of blank gear.

In the manufacture of bevel gears it is first necessary to determine the diameter and angles of blanks that they may be turned correctly, after which we are ready to cut the teeth and unless the cutting angle is correct and the machine set true we shall have half a tooth at the last cut, which is a loss of time and material. It is also important to select correct cutters, and in the list of formulae following will be found two which are prepared for this purpose.

Selection of Tooth.

In the selection of a tooth form the involute or single curve tooth is now almost universally used for bevel gears, in place of the cycloidal or double curve tooth and it may be well to also state that the number of teeth and diametral pitch or the pitch diameters, must be selected in the design of a pair of bevel gears, which selection is largely influenced by the existing conditions. In ordinary machine design the available space is a large factor from which we may determine the pitch diameters. The number of teeth in each wheel is determined by the speed ratio required. If the wheel driven is to have 3 revolutions to one of the driver, the number of teeth could be 30 and 10, 36 and 12, 24 and 8, etc. Following, are three formulae from table of tooth formulae which

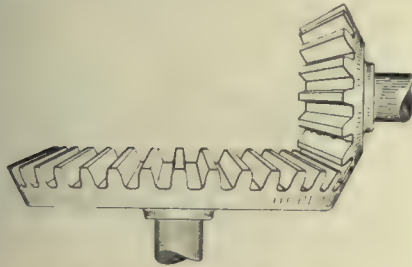

Fig. 1.—90 Degree Bevel Gear.

consideration of which enters largely into the successful design of all gears whether spur, bevel, or spiral.

TABLE OF TOOTH FORMULAE

N = number of teeth	$N = \frac{D \cdot P}{P}$	$N = DP$
P = diametral pitch	$P = \frac{N}{D}$	$P = \frac{2.1545}{D}$
D = pitch diameter	$D = N \cdot P$	$D = P \cdot N \cdot 1.1545$
p = circular pitch	$p = \frac{3.1416}{P}$	
a = addendum = working depth of tooth	$a = \frac{1}{P}$	$a = 2.1545 \cdot p = \frac{2}{N}$
c = clearance at bottom of tooth	$c = \frac{.0075}{P}$	$c = p \cdot .05$
f = full depth of tooth	$f = (a) + c$	$f = \frac{2.162}{P}$
t = width of tooth on pitch circle	$t = \frac{2}{P}$ for cut gears	$t = .68 \cdot p$ for cast

These formulae have been compiled from standard authorities and represent the relative proportions which exist between the diametral pitch, number of teeth, pitch diameter, circular pitch, addendum, etc., the diametral pitch being the number of teeth to each inch of pitch diameter. The pitch diameter is the diameter of the pitch circle, which is always described through the centre of the working depth of teeth. In bevel gears, it will be found on the edge line or upper slant of teeth, and on it is measured the circular pitch, or distance from the centre of one tooth, to the centre of the tooth adjoining. The addendum is equal to the addenda; and is always one-half the working depth of tooth. The diameter of blank is readily found in spur gears, by adding the working depth of tooth or twice the addendum, to the pitch diameter, but in bevel gears it must be calculated as the following diagram, Fig 2, indicates, since the calculated dimensions of teeth are on the edge line.

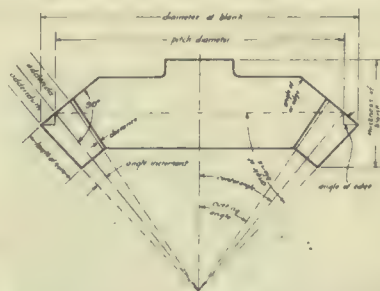

Fig. 2.—Illustrating Tooth Formulae.

The angle of edge is equal to the centre angle, since the edge line or upper slant of teeth is at right angles with centre line of teeth. The angle of small fri-angle in right hand corner is also equal

aid materially in determining the number of teeth and diametral pitch:

$$N = DP \quad P = \frac{N}{D}$$

Let us design a pair of bevel gears

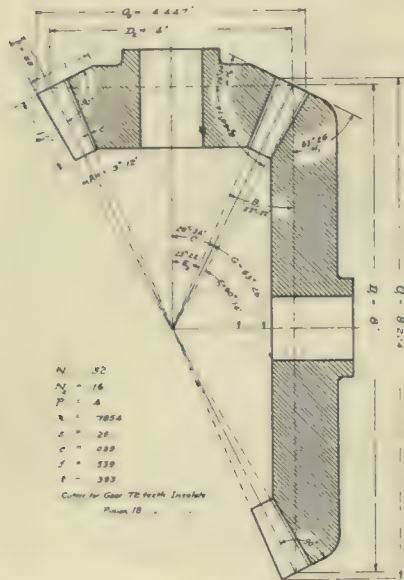

Fig. 3.—Pair of Bevel Gears, Shafts at Right Angles.

with shafts at right angles. Fig. 3 is a gear and pinion, and following are a list of formulae necessary for their calculation, the angles and dimensions are lettered for convenience.

Example.

TABLE OF FORMULAS FOR 90° SHAFTS.

G = center angle of gear = angle of edge of gear	$\tan G = \frac{N_2}{N_1}$	G = 90° - C
C = pinion	$\tan C = \frac{N_1}{N_2}$	C = 90° - G
A = angle increment	$\tan A = \frac{N_2 - N_1}{N_1 + N_2}$	$\tan A = \frac{E_2 - E_1}{E_1 + E_2}$
E = cutting angle of gear = angle of blank of pinion	$E = G - A$	
E ₂ = pinion	$E_2 = G - A$	
B = angle of blank of gear = cutting angle of pinion	$B = 90° - (G + A)$	
B ₂ = pinion	$B_2 = 90° - (C + A)$	
Q = diameter of blank of gear	$Q = (2 \cos G) + D_1$	
Q ₂ = pinion	$Q_2 = (2 \cos C) + D_2$	
Number of teeth to select Cutter for Gear = $\frac{N_1}{\cos G}$		
Pinion = $\frac{N_2}{\cos C}$		
N ₁ = number of teeth in gear	see table of tooth formulae	
N ₂ = pinion		
D = pitch diameter of gear		
D ₂ = pinion		
a = addendum		

In the design of a machine, we have an available space of 10 inches, and have decided to use 8 inches as the pitch diameter of gear, and as the speed ratio is to be 2 to 1 we shall select 32 and 16 teeth.

The diametral pitch may at once be determined by the tooth formula

$$P = \frac{N}{D} \quad \text{or} \quad P = \frac{N_2}{D_2} = 4 \quad \text{and our pitch diameter of pinion found by the formula}$$

$$D = \frac{N}{P} \quad \text{or} \quad D = \frac{N_2}{P} = 4 \quad \text{inches our gears will therefore be 32 and 16th teeth, 4 pitch$$

from which we shall proceed to calculate the balance of tooth dimensions.

The circular pitch
3.1416 3.1416

$$P = 4 \quad \text{The addendum is readily found by the formula}$$

$$a = \frac{1}{P} = .25'' \quad \text{The width of tooth is found by the formula}$$

$$p = .7854$$

$$t = \frac{2}{P} = .3927'' \quad \text{Clearance is}$$

$$t = .3927''$$

$$c = \frac{10}{10} = .039'' \quad \text{and the full depth of tooth} = (2.5) + c = (2 \times .25) + .039 = .539 \text{ in.}$$

The foregoing will be found noted on

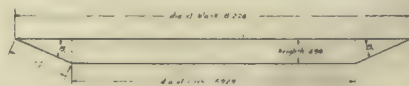

Fig. 4.—Bevel Gears, Finding the Diameters.

Fig. 3, and we shall proceed to calculate the angles.

The tangent of centre angle of gear
N₁ 32

or tangent G = $\frac{16}{32} = .5$
N₂ 16

and its angle is 63° - 26° = H₁ the centre angle of pinion or C = 90° - G = 90° - 63° - 26° = 26° - 26° = 34° = H₂. The tangent of the angle increment is found by the formula
sine c .4472

ula tangent A = $\frac{1}{2} \frac{N_2}{N_1} = \frac{8}{32} = .25$

and its angle is 3° - 12°. The cutting angle of gear which is the angle of blank of pinion is found by deducting the angle increment from centre angle of gear or E₁ = G - A = 63° - 26° - 3° = 34° - 12° = 22° = B₂. The cutting angle of pinion which is the angle of blank of gear is found in the same way or E₂ = C - A = 26° - 34° - 3° = -12° = 23° - 22° = B₁. These angles will be found noted in their proper place on Fig. 3.

We have yet to determine the diameter of blanks and size cutters to use, as these formulae are calculated with cosine G and cosine C. We have been obliged to leave them until the angles were calculated. The diameter of blank of gear will be found by the formula
O₁ = (2.5 cos G) + D₁ = (2 × .25 × .4472) + 8'' = 8.224 in., and the diameter of blank of pinion O₂ = (2.5 cos C) + D₂ = (2 × .25 × .8944'') + 4'' = 4.447 inches. With respect to the cutters, the number of teeth to select cutter for gear

$$N_1 = 32 \quad \text{= 18 teeth or an}$$

Cos, G .4472
volute 4-pitch bevel gear cutter, which will cut 72 teeth, and the number of

teeth to select cutter for pinion
N₂ 16

$$\frac{16}{\cos, C} = .8944 = 18 \text{ teeth or on}$$

involute 4 pitch bevel gear cutter which will cut 18 teeth. It is evident that two cutters will be required to cut these wheels, as gear cutters are usually arranged in sizes, and each size has a certain range of teeth to cover. The calculated numbers of teeth, are the numbers of teeth of an equivalent spur gear and pinion having the same profile. One cutter will often do for both wheels, but the formulae readily determine this. These quantities have been noted on Fig. 3, which practically completes the calculations. The size of hub will, of course, be governed by the diameter of shaft it is to be fastened to, and the length of teeth is largely influenced by the power on shaft and particular purpose of the gears.

Machining Blanks.

If we are to have correct, smooth, and easy running gears, we must provide correctly turned blanks. A method to facilitate the turning of blanks, may be briefly described as follows. After the disc is turned to conform to the diameter of blank, we are ready to turn the lower slant or face of teeth. In order to determine how much metal to remove, we must define the end of teeth on bottom of disc by a circle, which can be scribed by the compasses, and its diameter found as in the following diagram Fig. 4.

The diameter of circle should be calculated to insure greater accuracy, also the height; if we decide to make length of teeth 1½ inches, the diameter of scribed circle = O₁ - (2 × 1½ × cos B₁) = 8.224'' - (2 × 1½ × .918) = 5.929 inches and our height = 1½'' × sin B₁ = 1½'' × .3966 = .496 inches. This distance should be laid off on the side of disc from bottom and a line scribed all around the blank to define it, and after the circle is scribed on the bottom we have two lines to turn to. This operation completed we are ready to try the angle with a protractor, which is illustrated in Fig. 5.

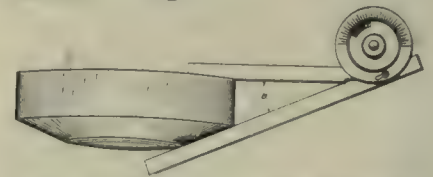

Fig. 5.—Trying Angle With Protractor.

If the slant conforms to angle B, we may proceed to cut the edge line or top slant of teeth, and shall have a similar diagram to the one before (Fig. 4) except it is reversed. The angle of top slant is the angle of edge H₁, or centre

angle, and the length of edge line is the full depth of tooth .539 inches plus sufficient margin to insure proper strength to the wheel. We shall call the full length of edge line, one inch in this case, and calculate diameter of top circle to turn to, which equals $O_1 - (2 \times 1 \times \text{csc } H_1) = 8.224'' - (2 \times 1 \times .4472) = 7.33$ inches, and our height is $1'' \times \sin H_1 = 1'' \times .894 = .894$ inch. After the operation of turning the edge line is completed, we are ready to try the angle with a protractor, which is illustrated in Fig. 6.

This slant should conform to the angle of edge or angle H_1 , after which we are ready to cut the teeth. This operation may be performed with an automatic gear cutter, or a milling machine. The

cutting angles as calculated are correct for both machines. We have, however, neglected to properly proportion our disc, which is the starting point of our

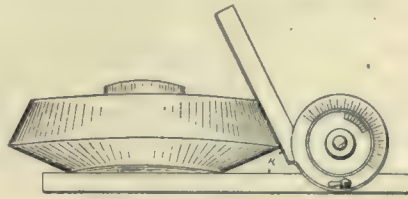

Fig. 6.—Trying Angle With Protractor.

turning operations. These preceding calculations are necessary to determine its thickness, which is the sum of the two heights, as calculated, $.496'' + .894''$

$= 1.39$ inches for the gear, providing the wheel is to have no hub. If a hub is required, we must add its height to 1.39 inches. The diameter of disc is the diameter of blank 8.224 inches. These turning operations may be reversed, and the top slant turned first, if such a course seems desirable, also the included angle of the finished blank is readily found by adding together angles H and B.

In article 2, which is to follow, will be described a method for the calculation of all bevel gears other than those with shafts at right angles, or bevel gears with shafts of acute and obtuse angles.

A Great Saving Effected by the Use of the Disc Grinder

Figures Given Herewith by the Gardner Machine Co., Beloit, Wis., Show Great Savings in the Auto, Marine and Stationary Motor Industry

The Disc Grinder has found an increased usefulness in the auto, marine parts being finished on a No. 6 Gardner (grinder).

hold the jacket-plate during the operation. Fig. 1 gives an idea of the belt power and the heavy type grinder, equipped with 23-inch disc wheels and lever feed table.

Fig 2 shows the arrangement for grinding cylinder covers, which required only $1\frac{1}{2}$ minutes each. Fig. 3 shows the

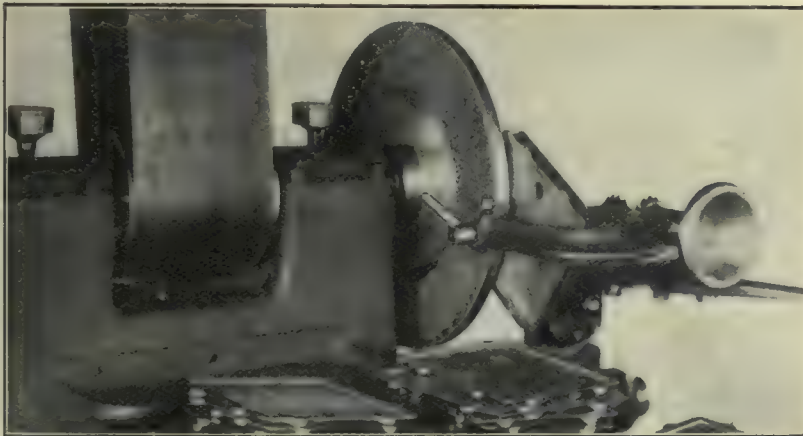

Fig. 1.—Grinding Jacket Plates, Showing Special Jig.

and stationary motor industry, whereby the time of accomplishing certain work has been considerably reduced. In most work the grinder is used in conjunction

Fig. 1 shows a jacket plate being ground. Each piece was finished in $2\frac{1}{2}$ minutes. A special jig was used to

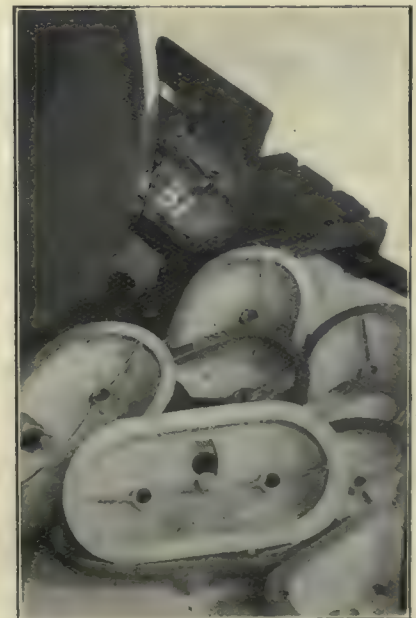

Fig. 2.—Grinding Cylinder Covers.



Fig. 3.—Grinding Exhaust Connections.

with a planer, shaper or lathe, but the time given for the parts mentioned in this article is for grinding alone, the

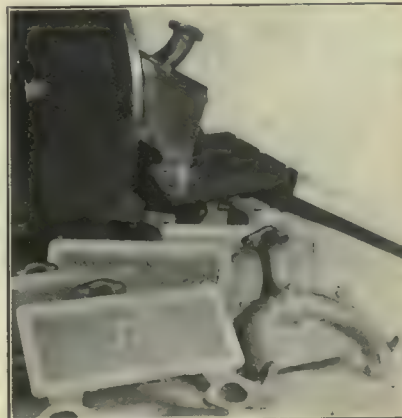

Fig. 4.—Grinding Intake Manifolds.

grinder equipped for exhaust connections, which were ground at the rate of 3 minutes each.

Fig 4 shows the grinding of intake manifolds at the rate of $3\frac{1}{2}$ minutes each. This time includes grinding the large area and the single flange at a given angle, completing it in the time mentioned.

Electric Lifting Magnet Now in Use in Canada

Magnets are Now Used in the Canadian Locomotive Works, Kingston, and in the Angus Shops, Montreal—Used for Lifting Plates, Pig, Iron, Scrap, etc.

The grinding of pump-cases is shown in Fig. 5. The time required is 2 minutes each, which includes grinding large area and the bracket area parallel.

The pieces shown in Fig. 6 are universal joints. The grinding operation takes

to six at a time, one under the other, the number depending upon their thickness. These may be dropped by the magnet one at a time at the desire of the operator provided he is clever in

The magnet that boys of yesterday used for a toy to-day as men they are employing as a useful instrument in their workshops. Within the last few years particularly, it is being adapted



Fig. 5.—Grinding Pump Cases.

1½ minutes each. These pieces are malleable iron castings, about 6 inches in diameter.

In addition to the operations mentioned there are a great many more in the engine factory to which a modern disc grinder is adapted, flange seats, push rods, cams, piston rings, thrust collars, crank cases, gear cases, manifolds, couplings, etc. The adoption of the grinder has assisted in producing a greater output with an equal or superior finish.

F. W. Cowie is giving a course of lectures at McGill University on Har-



Fig. 6.—Grinding Universal Joints.

bor Engineering. The course includes instruction in the building of docks and wharves, the preparation of approaches, and all the general features of port development.

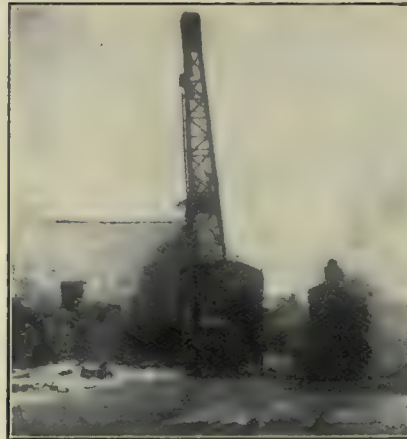

Fig. 1.—Front View.



Fig. 2.—Side View.

to handle many shapes of metal, all forms of iron and steel, from iron dust to scraps, or small junk to weights of 20,000 pounds. In fact, the world's largest magnet will lift as much as 50,000 pounds.

The magnet is employed to break up imperfect castings, to hold sheets of metal in position while they are being riveted in the building of ships, to lift a "sow and pigs" at the furnaces, also

adjusting the switch at precisely the right intervals.

Canadian Locomotive Works.

Probably the first installation made in Canada was that at the Canadian Locomotive Works, Kingston, where a magnet was delivered by the Browning Engineering Co., Cleveland, on March 13, 1908.

This installation includes a standard No. 8, Browning Locomotive Crane, which is designed to carry a 7½ or 10



Fig. 3.—Magnet Handling Machine Scrap.

as a gigantic broom to sweep both the large and small pieces of iron, and in numerous other ways.

The flat style of magnet is available for picking up metal sheets, from two

h.p. steam generating set to operate our lift magnets. For this purpose it is equipped with extra large boiler, 54 in. diameter and 8 foot 6 inches high, with corresponding increase in water

and coal capacity. Coalbunker holds 1 ton of coal. Watertank holds 300 gallons, and engines have 8 by 10 inch cylinders.

Fig. 1 shows a front view of the magnet beside a new C. N. R. locomotive which is being tested. Fig. 2 shows a side view of the crane. When used on a locomotive crane the current for operating the magnet may be brought from an outside source, using flexible cable or other convenient means to connect to the magnet controller, so as to allow the crane to perform all its functions freely, or it may be generated on the crane itself by a steam driven generator set.

Angus Shops Instalation.

An instalation of an electro-magnet and crane was made at the Angus Shops, Montreal, early in 1909, many uses being there found for it, loading scrap, unloading pig iron, etc. It also was made by the Browning Engineering Co., Cleveland. It is found to do the work cheaply and efficiently. Fig. 3 shows the electro-magnet handling scrap.

Description of Magnet.

The frame of the magnet is of open hearth steel of special analysis and treatment suitable for electric magnet use. The top of the frame is deeply corrugated to provide radiating surface. The outer ring and inner pole are made of the same special steel as the frame, and are so designed as to be easily and cheaply replaced when worn. The inner faces of the magnet frame and ring are machined to exact dimensions so that the coils fit closely, and the heat generated in the coil is quickly transmitted to the metal on every side.

The coils are wound with copper wire which is covered with special fire-proof non-absorbent insulating material. The coil is a homogeneous cushion having the requisite number of turns of wire imbedded in it at uniform spaces from each other. The coils are made of such size as to completely fill the space in the frame and when the several parts of the magnet are bolted together are tightly clamped in place.

Two coils are used in standard magnets which are connected in series for 220 volt circuit, but which may be connected in parallel and used on circuits of 110 volts. For 500 or 550 volts special coils are furnished.

HOW BILLY CENTRED SHAFTS.

Mr. William Collis, affectionately known amongst the boys as "Billy," was the foreman of the turning shop some twenty years or so ago. He was a working foreman too—not one of the kind who was afraid to dirty his hands—and to fill in his time between Monday morning and Saturday noon, when he was not giving out work or looking

after his men he ran the shafting lathe—or rather the shafting lathe ran itself even when he was looking after the men, or when he was dozing on the top of his tool-chest, for in that shop there was no tool-room and each man kept his own special fancies in the way of

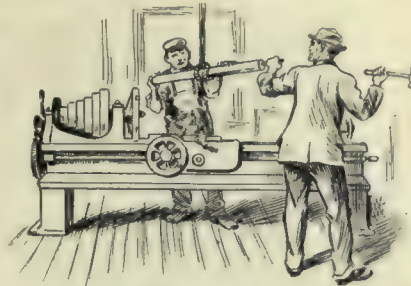

Fig. 1.—"Now Billy's Method of Centering Shafts was Primitive."

tools, etc., under lock and key. High-speed steel was in the dim and distant future, and a cut over a shaft lasted a long time.

Now Billy's method of centreing was as primitive as could be, the usual tools consisting of a centre punch and hammer only. A square centre was used sometimes, but this gave trouble in changing centres, putting something in the tool-post to press the shaft, and other little worries which could be avoided; therefore, by placing the centre punch where he guessed the centre of the shaft should be, and hitting it several good smart blows the thing was done—except, of course, when he had miscalculated as to the exact position of the centre. It was then necessary to try the shaft in the lathe, and if too much eccentricity was found he would mark the "high side" with chalk, remove the shaft and "draw" the centre by means of the punch, the shaft being swung in and out of the lathe by means of pulley blocks.



Fig. 2.—"Our Regret is that we Don't Know the Tool-Smith who Forged that Centre-Punch and the Concern that Made the Hammer."

His assistant on the operation was generally one of the newer lads knocking around, and for the particular shaft in the story the services of Harry had been secured. Now Harry's sense of humor (?) was strongly developed, and he hated this particular job just as much as he was afraid of Billy, but his love of a joke overcame his fears one

day, and here is the story as told in Machinery:

Billy had made a particularly bad guess as to the position of the centre of the shaft and had followed his usual practice up to the point of swinging the shaft out of the lathe, when he was called away to attend to some other duty. As Harry lolled around waiting for the work to proceed again, the little chalk mark persistently stared him in the face in such a manner that finally an idea struck him, that it would be funny if he rubbed it out and placed another on the opposite side. Of course, as in most things of importance, the main thing was to have the idea, the rest was easy and was soon accomplished. It was too good a joke to be enjoyed alone and several others soon knew what had been done, amongst them being one of Billy's own particular cronies. Billy returned soon afterwards, and resuming operations, drew the centre towards the mark. His surprise was very pronounced when he saw the result of his latest efforts and the remarks he made about shafts in general and this one in particular are unprintable, but he fairly lost his temper when caught sight of someone smiling, apparently at him.

Poor Harry wanted to laugh, too, but dared not, so offered what consolation he thought would meet the case, suggesting that Billy had perhaps made a mistake, and should have drawn the centre away from the mark, but Billy said he might do that when he started his second apprenticeship and knew no better. From his manner towards his assistant the next day it was clear he had learned over night what had occurred, but he was not vindictive, and afterward enjoyed the joke as much as anyone.

How Billy Didn't Centre Shafts.

This startling sketch, Fig. 2, illustrates an amateur artist's weird conception of a shafting lathe and a machinist's way of handling centreing tools. He was asked to make a drawing for "How Billy Centred Shafts" and the result exceeded our wildest expectations. We are impressed particularly with the lathe legs. How well they don't harmonize with modern ideas of machine design; they appear to us to belong to the bulldog type of architecture! Note the "patent" head-stock and the "unpatent" foot-stock, and the doleful expression of the cub, who can't for his life see how to swing an eight-foot shaft between five-foot centres. The carriage is a gem—but why proceed further? The makers are unknown and we don't care. Our regret is that we don't know the toolsmith who forged that centre-punch and the concern that made the hammer.

An Effecting of Savings by Studying Steel Heating Costs

A Review of the Most Economical Methods for Heating Steel in the Manufacturer's Plant, Giving Tables of Costs of Various Systems

By W. ALMON HARE, B. A. Sc.

Producer Gas.

Producer gas from soft coal finds its special field in regenerative furnaces for re-heating billets and slabs for the finishing mills and for the soaking pits of the blooming mill.

Although some installations have been made in which a number of different sizes of small furnaces have to be heated, the system has many drawbacks and in such instances has no advantages over direct fired coal, either on the ground of economy or output.

To those who consider the matter impartially, this conclusion is at once seen to be correct. In the first place with the bituminous coal producer, the same fuel is burned as is required when the furnaces are fired direct by mechanical stokers. It is evident that whatever losses occur in the producer are entirely lost by the system and that the gases arriving at the furnaces are poorer by this amount. In the case of direct firing by mechanical means the heat units in the coal are all liberated in the fire box of the furnace.

From a theoretical standpoint the losses in the furnace itself arising from radiation, stack gases, chemical reactions, etc, represent an enormous proportion of the heat units delivered in the coal, but these losses do not differ very much if at all with the different methods of heating, and within certain limitations, cannot be very much reduced. The losses which occur in the producer are very much greater than those occurring in the fire box—and in this way the ultimate economy will be higher with direct fired coal than with gas producers.

Prof. J. W. Richards, of Lehigh University, has made a very extended investigation into the bituminous coal gas producer, and in a paper written by him on the subject gives the following as the losses which take place.

In the Nov. 1909 issue, Mr. Hare gave tables of the various systems and fuels. Tables of costs were also given comparing the cost of heating steel by stoker fired coal furnaces and natural gas furnaces.

In an early issue Mr. Jacobs of the Francis Hyde Co., Montreal, will give an article with tests on steel heating and will discuss costs of operating.

	B.t.u.	P.C.
Lost by carbon in ash	284.05	2.17
Lost by Radiation and Conduction	659.81	5.07
Lost by Sensible Heat in Hot Gases and Steam	1,866.73	14.35
Total Heat Lost in Producer	2,810.59	21.59
Calorific Value of Gas Produced.....	10,189.41	78.41
Calorific Value of one lb. of Coal	13,000.00	100.00

By the above it will be seen that there is a direct loss of 21.6 per cent. in the producer itself, and this loss cannot by any present means be prevented, hence the coal consumption per ton of steel will be 27.5 per cent. higher than with direct mechanical firing.

In large plants this loss is partly overcome by the use of regenerative chambers for heating the air and by the greater distribution of the flame, but in moderate sized furnaces these features offer nothing to offset the loss of heat in the producer itself, and as a result much better economy can be secured by firing the coal direct, and especially if automatic stokers are used.

In large plants, where one or two producers are supplying gas to a number of furnaces, fairly good results can be obtained with all furnaces in operation, but in times of depression when some of the furnaces are out of commission, the coal consumption per ton of steel heated on the remaining furnaces is much increased, and when the amount of gas required is very much below the capacity of the producers, the coal consumption is prohibitive. It will be noticed that this increase in coal consumption takes place at times when the management are most desirous of reducing operating costs, and therefore this system is very disadvantageous on that account.

Anthracite Coal.

This fuel possesses one advantage in that it is smokeless and also in the fact that the design of the furnaces does not involve anything very difficult, but apart from these points there is nothing to commend it, for at the prices now being paid for hard coal, the cost of operation is very high. Usually the type of furnace adopted for this fuel would consist of a flat grate with a closed ash pit, bricked up at the sides, and with a roof sprung across. The steel bars to be heated are laid on the fire and are heated in this way. The coal burned per ton of steel varies very much in differ-

ent plants, principally due to the nature of the work in hand and the output of the furnace. It is not unusual to find a coal consumption of 600 to 800 lbs. per ton of steel which with coal costing \$5 per ton, means a fuel cost per ton of steel of from \$1.50 to \$2.

With furnaces burning soft slack coal and mechanically fired, very much lower costs are obtained, as will be seen from the figures given below.

Tests of a track bolt furnace burning bituminous slack coal, and fired automatically by an American mechanical stoker.

	No. 1	No. 2	No. 3
Total weight of steel heated, lbs.	7,500	8,000	10,200
Total weight of coal burned, lbs.	1,445	1,590	1,875
Pounds of coal per ton of steel heated, lbs.	386	398	370
Cost of slack coal per ton	\$3.60	3.60	3.60
Fuel cost per ton of steel	\$0.69	0.72	0.67
Average of three days run	\$0.69		

The hard coal furnaces operating in the above plant will not average better than 700 lbs. of coal per ton of steel, and with hard coal at \$5 per ton, fuel cost per ton of steel would be \$1.75. The saving due to the change is, therefore, \$1.06 per ton of steel or 60 per cent. In addition to the reduction of cost, the output has been very much increased as the operator does not have to wait for the steel to heat up, and with the stoker the fire can be forced if desired.

Crude or Fuel Oil.

Much has been said or written regarding the advantages of liquid fuel, but after all the final test is cost of heating a ton of steel and while it is quite true that fuel oil will show a considerable reduction in cost over other fuels in some instances, it cannot be said that this is to be taken as being true for all classes of heating.

It is not to be denied that for certain operations in railroad or other shops where it is necessary to carry the heat to the work, that the portable oil furnaces is by a long way the most desirable, but in these cases, the actual cost of the fuel is completely overshadowed by other practical considerations. For such work as tool tempering, especially in very small furnaces, no fuel, unless it be gas, can be used with the same cleanliness and complete control as fuel oil, but where a large output is required

aggregating over 1,000 lbs. of steel per day, a properly designed slack coal furnace mechanically fired will show much lower costs of operation.

The reason for this is due entirely to the high cost of the oil, for in the distribution of the heat units in the furnace

One dollar's worth of oil at 4 cents per Imperial gallon, will generate 3,950,000 B.t.u., taking the sp. gr. at .79, and the calorific value at 20,000 B.t.u. per lb. The ratio, therefore, of coal to oil in heat units for the same cost is as 2.42 to 1.

In the test given below it will be not-

Additional fixed charges on stoker furnace in interest and depreciation per day....	0.18	
Total cost of fuel, labor and fixed charges per day	\$2.53	\$4.05
Total ditto per ton of output...	\$2.05	\$3.50
Relative cost of coal and oil...	58 p.c.	100 p.c.
Saving per annum of 300 days in favor of the stoker face.	\$456.00	
Weight of steel heated for one dollar, fuel only, lbs.....	1,274	579
Ratio of coal and oil in output at same cost	220	100



Carriage Axle Furnace

and the efficiency of the furnace itself apart from the source of heat, oil or gas will operate the furnace more economically than by any solid fuel. By this is meant that, owing to the less volume of air passing through the furnace and consequently the nearer approach to exact theoretical requirements, the higher the furnace temperature will be for the same number of British thermal units liberated, and as a further result, less waste will be passing up the stack. Notwithstanding this advantage, the final result of a trial between oil and soft slack coal, stoker fired, is very much in favor of the coal. Taken on a basis of B.t.u. purchasable for \$1, the difference is considerable. Soft slack coal having the following analysis can be purchased for \$3 a ton (2,000 lbs.) and is known as Pittsburg gas slack:

Carbon	62.64 p.c.
Volatile Matter	31.09 p.c.
Ash	6.41 p.c.
	100.14 p.c.
Sulphur	1.00 p.c.
Calorific value	14,468 B.t.u.

One dollar's worth of this coal will when burned, generate 9,650,156 B.t.u.

iced that the coal furnace burning slack at \$3 per ton, heated 1,274 lbs. of steel for one dollar, while the oil furnace burning oil at 4½¢ per Imperial gallon, heated 579 lbs. for the same cost, or in the ratio of 2.2 to 1.

In both tests the economy was very poor, but they are both from the same furnace, being taken before and after a change of fuels.

Test of a nut furnace fired by oil and afterwards changed to stoker firing, burning soft slack coal:

Nut Furnace	Coal	Oil
Output per day of nuts, lbs.....	2,460	2,316
Output per day of nuts, tons...	1.23	1.156
Inc. of coal face over oil, lbs....	144	
Inc. of coal face over oil, p.c.	6.3	
Cost of fuel per ton or per gal.	\$3.00	\$0.045
Quantity of fuel burned per day lbs. and gals.	1,333	90
Cost of fuel per day	\$2.00	\$4.05
Fuel burned per ton of steel heated, lbs. or gallons	1,093	77.8
Cost of fuel burned per ton of steel heated	\$1.57	\$3.49
Labor for handling coal and ashes, one man for 4 furnaces at \$1.40 per day, cost per day per furnace	\$0.35	
Total cost labor and fuel per day	\$2.35	4.05

In a recent test, conducted in one of the largest plants in Pennsylvania, a coal furnace fitted with a No. 5 stoker, averaged during 3 days a daily output of 11,400 lbs. of steel with a coal consumption of 288 lbs. of slack coal per ton of steel. This coal would cost in that location about \$1.50 per ton. With fuel oil at 3½ cents per gallon, an oil furnace would have to heat one ton of steel with a consumption of 6.1 gallons, in order to show the same fuel cost per ton as with coal, i.e. 21.6 cents.

In Ontario, where the coal will cost \$2.75 per ton, and the oil 4½ cents a gallon, the oil consumption per ton of steel would have to be as low as 8.8 gallons in order to equal the fuel cost with coal, or 39.6 cents per ton of steel

Taking everything into consideration, the oil system has a number of advantages over coal, such as the ability to get up the heat without extra labor, no handling of coal and ashes, etc., but when this is all considered, and everything accounted for, the cost of heating large quantities of steel will be higher than with a properly proportioned coal furnace, fired automatically by a mechanical stoker.

Bituminous Stoker Furnaces.

The reverberatory furnace fired by hand with lump coal is perhaps one of the most popular type of furnace in use to-day, especially in the larger units, such as are used for billets, axles, slabs, etc. It possesses the advantage of being self-contained and not dependent on the operation of any other part of the plant, with the exception of the forced blast blower, and unlike the gas fired furnaces the economy is not influenced by the number of furnaces in operation.

By hand firing, however, the best result is not obtained from the coal, though it was only within the last few years that furnaces of this type could be automatically fired by mechanical stokers, as it required a great deal of experimenting to determine the best proportions of the furnace when stokers were installed. Previous to ascertaining the correct data for building stoker fired furnaces, many failures, resulted,

due to inability to distribute the heat where required. Happily a considerable advance has been made recently, and a great deal of accurate data secured, which places the problem within the field of easy solution.

The results obtained by the application of stokers to furnaces of this type are summed up under the following heads:

- Steady uniform heat, resulting from continuous firing.
- Increased output, as less time is lost between heats, and as the furnace can be forced.
- Lower grades of fuel possible, as slack coal is burned instead of lump, and at a proportionately lower cost per ton.
- Smokeless combustion and clear flame, thus reducing the proportion of carbon monoxide escaping up the stack.
- A reduction of labor where a number of furnaces can be attended to by one fireman, as the stokers are operated automatically.
- Easy regulation of the character of the flame, owing to independent control over both coal and air supply.
- Reduction in amount of slag or scale, due to non-oxidizing nature of the flame.

In a test of a furnace fitted with mechanical stokers in comparison with one of practically the same general dimensions, and fired by hand, resulting in the following figures:

	Hand	Stoker
Date of test	Sept. 29, '08	Sept. 29, '08
Duration of test, hours	23.75	23.00
Furnace number	2	1
Method of Firing	Hand	Stoker
Make of stoker "American" Mechanical		
Size of stoker	No. 9	Type M
Total weight of coal used, lbs.	9,880	9,720
Total weight of steel heated, lbs.	50,010	58,140
Steel heated per pound of coal	5.065	5.93
Pounds of coal per ton of steel heated	394.8	337.2
Coal per ton of steel heated, lbs.		57.8
Saving of coal per ton of steel heated, p.c.		14.33
Total weight of scale, lbs.	1,447	1,435
Pounds of scale per ton of steel, lbs.	58	49.5
Reduction in scale in favor of stoker, p.c.		14.7
Total ash, p.c.	2.277	815
Per cent. ash	23	8.38
Total tons of steel per year	5,800	7,000
Total tons of coal per year	1,147.5	1,170
Inc. outout of stoker face, p.c.		20.7
Increased economy of stoker face, p.c.		14.33
Cost per ton of steel on basis of \$3.00 coal	\$0.59	\$0.50

In the above instalation the application of the stokers resulted in an increase of output of 20.7 per cent., and a reduction of fuel cost per ton of output of 14.33 per cent. In addition to these savings, the stoker furnace was paying less for its coal, which resulted in a

still greater financial return than the above figures indicate.

If the above test had been conducted in Canada, where in some parts, principally in Ontario, a difference between the cost of lump coal and slack amounts to nearly \$1 per ton, the saving from the use of the stoker would have been very considerable, amounting to about \$5 per day, or \$1,500 per year, thus returning the entire investment in a few months operation.

The following test was made on a Guide mill furnace, after fitting same with two mechanical stokers:

	Data
Type of furnace—Guide mill, reverberatory.	
Length of hearth	16'-0"
Width of hearth	6'-2"
Grade of "coal"—West Virginia Nut	
Number of stokers	2
Type and make of stokers—"American" Mechanical	No. 9, Type M
Time of run 5 turns of 11 hrs each, hrs.	55
Total weight of steel charged per heat, lbs.	8,200
Total weight of finished steel	206,298
Total weight of coal burned	29,272
Coal burned per ton of steel heated, lbs.	284
Fuel cost per ton of steel heated @ \$3.00 per ton	\$ 0.426

small watertube boilers, which will extract fully 60 per cent. to 70 per cent. of the heat units remaining in the stack gases, and it is shown by the results of many instalations of this kind, that the steam so generated will be sufficient to supply all the necessary power for the operation of the forging machinery, and perhaps in some larger instalations, leave a margin for other purposes.

In this way, in a properly designed plant, where furnaces, boilers, engines, etc., have been carefully laid out as a whole, it is possible to operate the plant with no further expenditure for fuel or other power than the soft slack coal necessary for the furnaces alone.

It must not be assumed that this happy result can be arrived at by purchasing equipment at random, for there are certain conditions that must be met, which can only be successfully surmounted by proportioning the different units to one another.

Several U. S. railways are experimenting with mechanical stokers for locomotives. In very few cases have accurate tests been taken, and those that have show results unfavorable to the



Axle Furnace, with Stoker.

The economy shown in this test is very much better than that obtained elsewhere, and at which time the furnace was hand fired.

Saving Waste Heat.

In connection with the coal fired steel heating furnaces there can be installed

stoker. Where the firing is well within the capacity of one man without mechanical aid there does not appear to be much reason for installing mechanical stokers, although in America it is hoped that they will help to abate the black smoke nuisance.

MACHINE SHOP METHODS ^A_N^D DEVICES

Unique Ways of Doing Things in the Machine Shop. Readers' Opinions Concerning Shop Practice. Data for Machinists. Contributions paid for.

MAKING SHOP BRIGHTER.

In one of the machine shops of the Canadian Locomotive Works, Kingston, experiments have been made in the



Fig. 1.—Making the Shop Brighter.

painting of the machines which resulted in a considerable brightening of this shop. Fig. 1 shows a planer and Fig. 2 a slotter. These give an idea of the appearance of the machines when painted white.

Ordinary paint cannot be used as the



Fig. 2.—Making a Shop Brighter.

oil used to lubricate the machine, will in time dissolve the paint so that the machine would soon be left in the same

condition as before without producing any increased light in the shop. The machines shown and the others in the shop are enamelled. It is an expensive operation but it gives excellent results. Besides, the workmen can easily clean their machines without fear of removing the paint. In Fig. 2 the contrast between the white and dark machines may be seen, the one at the left not being enamelled.

TO PUT ON DRIVE BELT.

By Frank E. Booth.

As is well known, a large belt is usually put in its place by tying it to the drive wheel rim and turning engine over.

The objection to this method is that the belt gets twisted and crumpled very often, which might shorten its life of service.

While installing an engine in an electric power house up the country, the writer saw the engineer work a first-class scheme for putting on a large drive belt, which is illustrated by the accompanying sketch.

A piece of wrought iron pipe was placed across the face of the wheel, as shown, being tied with a piece of rope to the wheel arm C, at one end, while a longer rope was run to the arm, A,

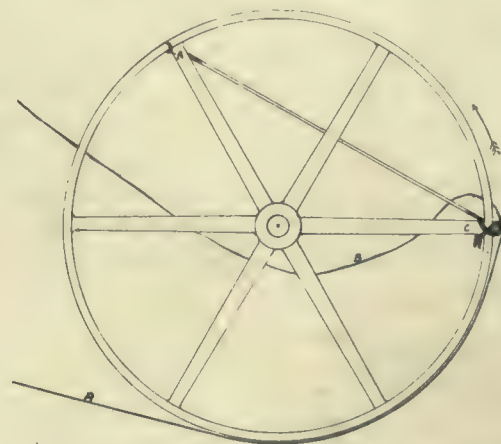

To Put on Drive Belt.

from the other end. The belt had approximately the location, as shown by heavy line B, when the engine was turned over; the long rope being underneath belt. The belt will slide on quite smoothly when the wheel is moved in the direction shown by arrow.

MACHINING LARGE GEARS.

The William Hamilton Co., Peterboro, had to machine two large gear wheels of large size. The pitch diameter was 66½ inches and each gear was 11 inch face with 52 teeth of 4 inch pitch. These



Machining Two Large Gears.

were for driving pump for the Peterboro water supply.

In order that they should be exactly the same they were fastened together in the manner shown. The gears were then treated as one gear with a 22 inch face and the machining was proceeded with in the regular way.



WROUGHT IRON AND STEEL.

A writer in the Brass World gives the following formula for a solution for making an acid test to distinguish wrought iron from steel: water, 9 parts; sulphuric acid, 3 parts; muriatic acid, 1 part. These acids are poured into the

water and allowed to cool in a glass or porcelain dish. The test is made by immersing the samples in the solution for 15 or 20 minutes. After being rinsed and dried, the specimens, if iron, will show a series of fibres, with the slag interspersed between the fibres. Soft steel dissolves uniformly and without the fibrous structure found in wrought iron.

Commenting on this kind of a test, T. N. Thomson, principal of the School of Sanitary Engineering at the International Correspondence Schools, Scranton, Pa., says this shows that the corrosion of steel is different from the corrosion of wrought iron, the steel being uniform and smooth as compared with the jagged, fibrous character of the wrought iron corrosion. It also shows the reason why a piece of steel pipe should last longer than a piece of wrought iron pipe. The difference, however, in favor of the steel—as far as corrosion by that process was concerned—was so slight that good steel pipe can be considered to be at least equal to modern wrought-iron pipe in durability.

BORING BAR HOLDER.

By F. A. Rodgers.

I have a boring bar holder that will perhaps be of good service to some one. Herewith is a sketch illustrating it. The length A should be the length of top of compound rest. The bottom should be planed and lug B fitted to T-slot on top of compound rest; C is a T-headed bolt which fastens same. D is hole for bar and should be carefully laid out as the centre of the bar must be in line with the lathe centres, 1 15-16 is what I use. E is a tap screw which clamps the bar.

For boring small holes bars can be turned down to any size desired or bushings may be used. This holder grips

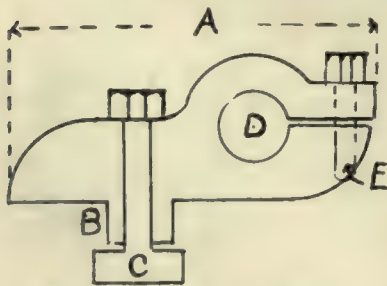

End View, Boring Bar Holder.

very fast and gives the bar a solid support. There is only one nut to tighten and no clamps or packing blocks are required.

VALVE GRINDING MACHINE.

In grinding valves and valve seats, great care must be taken to have the two parts fit closely together thus completely eliminating any chance of steam leakage. By a simple contrivance at the

Canadian Locomotive Works, Kingston, this is accomplished, a jig to hold the valve port being constructed, and driven by an ordinary compressed air motor. Both parts fit perfectly after the valve and seats are thus ground to fit.

The jig consists of three arms attached by bolts to a centre pin. The shape

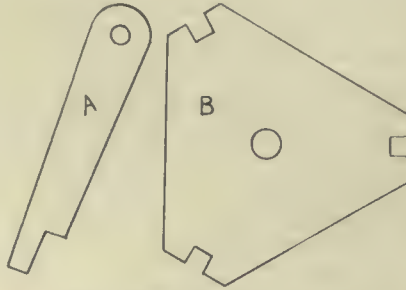

Valve Grinding Machine Parts.

of the arm is shown at A in the illustration. These three arms grip the seat. Underneath the arms is a triangular plate, B, having three slots in which the three arms rest. A nut on the centre pin squeezes the triangular plate up, thus holding the valve part tight while the grinding operation is removed.

FACTORY MESSENGER SERVICE.

By D. A. McLean *

Considerable annoyance and delay has been experienced by manufacturing concerns in transmitting messages from one department to another, and as these are

of an important nature care must be taken that they do not become lost or buried on some busy desk where they do not belong. The envelope system is probably the best in use to-day, a copy of which is shown on this page and the instructions at the top show for what it is intended.

The envelope may be of any size desired, but about 6" x 8" is a convenient size. The paper should be of good quality and the best suited for crasing.

In each department where messages are delivered and received boxes or baskets are placed marked "inward" and "outward." The messenger arranges a time table which is posted in each department showing the time he will call at that station.

In directing your envelope, simply place a pencil mark thus— opposite the name of the department or party you wish it delivered to and place it in the "outward" box where the messenger receives it, leaving the mark on until he reaches the station it is to be delivered to where he crases the mark and drops it in their "Inward" box.

This system will be found very convenient to every manufacturer and especially where there is a cost system in use, there being numerous time tickets, requisitions, etc., sent from the factory to the office.

* Chief Cost Clerk, Waterous Engine Works, Brantford.

Waterous, Brantford, Canada.

THIS ENVELOPE FOR FACTORY MESSENGER SERVICE ONLY.

To direct envelope place a check mark with a lead pencil, not Indelible, opposite the Department name in the blank.

DO NOT WRITE OTHER NAMES ON THIS ENVELOPE.

All envelopes are to be sent to the departments, the memos they contain being plainly marked for the parties for whom they are intended in the departments.

- | OFFICE: | FACTORY DEPTS. |
|--------------------------------------|-----------------|
| Andrews, W. (Accounting Dept.) | Bearings |
| Campbell, D. (Customs, etc.) | Blacksmith |
| Cost Office | Boiler |
| Engineering Dept. | Brass |
| Fux, J. A., (Chief Engineer) | Engine |
| Large, D. S., (Sales Dept.) | Fire Engine |
| Mair, Walter T., (Treasurer) | Foundry |
| Order Dept. | Governor |
| Photographer | Machine |
| Specification Dept. | Millwright |
| Waterous, C. H., (Pres. & Gen. Mgr.) | Main Stock Room |
| Waterous, D. J. (Vice-Pres. & Secy.) | Paint |
| Waterous, C. A. | Pattern |
| Waterous, L. M. | Portable |
| | Receiver |
| | Saw Mill |
| | Shipper |
| | Stock Shed |
| | Stores |
| | Sup't |
| | Tool Room |

AN INCLINED HYDRAULIC SYSTEM.

By Frank C. Perkins.

A novel lift system utilizing an incline plane is shown in the accompanying illustrations Figs. 1 and 2. Fig. 1 shows the inclined plane elevator car loaded with a heavy engine casting, while Fig. 2, shows the car platform of the lift in its lowest position.

Very heavy engine castings had to be transferred between the two floors of two workshops, where there was a considerable difference of level. This form of elevator was constructed as the most practical and economical on account of the castings in many cases being very long and producing unequal weights on the car.

It will be noted that the car provided is very long, moving on an incline plane of concrete with rails on the platform and a track below with a hydraulic cylinder placed on the incline between the rail.

By this construction there was no trouble encountered in loading very long pieces or placing the same on one side as the difference in weight on the various portions of the car had no influence on the proper working of the machine. The hydraulic cylinder on the incline in the centre of the track communicates with a vertical tank placed near the wall in the background and supplying the necessary power for raising the car. There is a valve provided in the piping connecting the cylin-

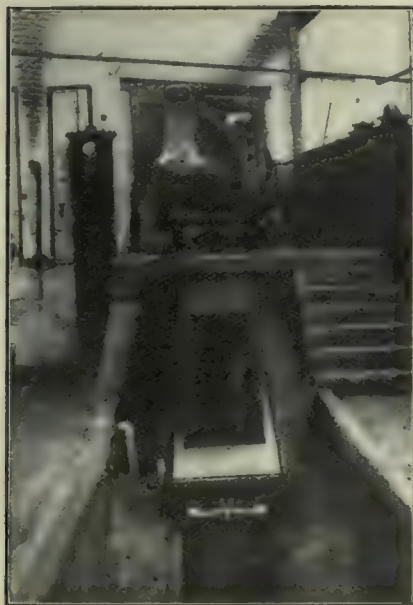

Fig. 1.—Incline Plane Elevator Car.

der with the tank, which is shut off in order that the car remains stationary wherever it is stopped. By closing this valve when the loaded car has reached the top of the incline, there is no possible way for the platform to slide down the incline. The vertical tank near the wall is connected with the

compressed air piping of the factory and the working of the elevator is extremely simple.

In order to lower the car when the platform is at the top of incline the compressed air is allowed to escape and the valve between the inclined

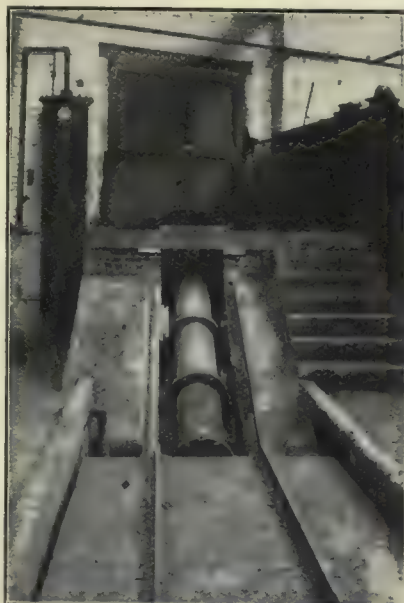
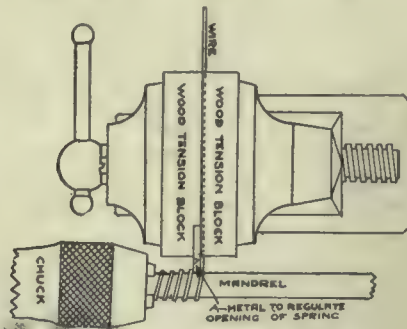

Fig. 2.—Car Platform in Lowest Position.

cylinder and vertical tank is opened by lifting a counterweight on the level of the cock. The car and platform reaches the bottom of the incline in about 30 seconds when the operation drops the counterweight and the valve is closed. If desired the air cock is then opened in order to be ready for immediate hoisting when desired, at the proper moment it only being necessary to again raise the counter-weight.

HOW TO WIND AN OPEN SPRING.

An easy way to wind a spring of the compression type will be found in the accompanying illustration. The mandrel on which the spring is wound is selected according to size of spring wanted. In this case the mandrel and the end of



How to Wind an Open Spring.

the wire were fastened in the chuck of a carpenter's brace. The piece A is a narrow strip of metal, the thickness of which regulates the spacing of the coils.

If a closed tension spring is wanted, the piece A is left out entirely. The wooden tension blocks are clamped with the proper tension in a vise. If no vise can be procured, an ordinary clamp will answer the purpose.—Scientific American.

VANADIUM STEELS.

Vanadium steels, their classification and heat treatment with directions for application of vanadium to iron and steel is the subject of an 84 page booklet by J. Kent Smith and issued by the American Vanadium Co., Frick Bldg., Pittsburg. Its toughening effect on steel is pointed out. Tables are given with regard to composition and heat treatment, the results given being deduced from experience with chrome-vanadium steels.

The use of vanadium steel for railroad work is dealt with, tables being given showing the application of vanadium steel with the type of metal and heat treatment. It is claimed that locomotive axles, springs, etc., may be made much lighter than now in common use and yet possess better tenacity and longer life. These steels are also applied to bridge work.

SCHOOL FOR RAILWAY MEN.

A School of Locomotive Instruction was recently started in Truro, N.S., in connection with the I.R.C. mechanical department. A large room in the Rest House at the Round House is used. The room is provided with railway appliances, regular classes are held and the men take a great interest in the discussions. Among the classes are those in mathematics, repair, care and despatch of locomotives, best methods, etc. Among those interested in the organization are: Charles McCarthy, a brake instructor, and James D. Turner, chief car inspector, and Superintendent of wrecking appliances of Moncton, and M. M. McLaren, chief train dispatcher of Truro.

BUSINESS ENGINEERING.

The faculty of science at McGill University have arranged for a course of lectures with a view to giving engineering students some knowledge of business. R. A. Ross, M.P., secretary of Ross & Holgate, has been secured to give a course of 25 lectures on business engineering or engineering economics, to third year students. For all departments but electrical engineering this course will be obligatory. Some of the subjects included in the course will be: Property currency, documents, securities, bonds, the Bank Act, the Companies Act, company financing and trust companies.

POWER GENERATION ^{A_ND} APPLICATION

For Manufacturers. Cost and Efficiency Articles Rather Than Technical.
Steam Power Plants ; Hydro Electric Development ; Producer Gas, Etc.

LOCOMOTIVE TYPE MARINE BOILER.

By A. W. Spotton.*

The Goldie & McCulloch Co., Limited, Galt, Ont., have recently supplied some marine boilers for use in British Columbia. These boilers were built for a working pressure of 200 pounds. The accompanying cut shows the boiler in course of erection and as will be noted the wagon top is of larger radius than the barrel and joined to it by a taper course. The fire box is exceptionally deep and provided with two fire doors, the upper one used when burning wood and the lower one when burning coal. The ash pit and smoke box are detachable and are bolted to the body of the boiler. The smoke box is provided with a spark hepper and spark arrester. The barrel of the boiler is 60 inches diameter and the wagon top 67 inches diameter. The fire box is 56 inches wide by 7 feet

long and the boiler contains 156 tubes two inches diameter by 14 feet long.

The longitudinal seams are double butt strapped and double riveted, while the circumferential seams are lap and double riveted.

Dimensions.

The following table gives the principal dimensions.

Diameter of barrel	60 in.
Diameter of wagon top	67 in.
Width of fire box	56 in.
Length of fire box	7 ft.
Number of tubes	156
Diameter of tubes.....	2 in.
Length of tubes	14 ft.
Length of smoke box	4 ft.
Overall length of boiler....	25 ft. 5 in.
Thickness of barrel shell	21-32 in.
Thickness of wagon top	32-32 in.
Thickness of tube sheet	9-16 in.
Thickness of crown sheet....	7-16 in.
Heating surface	1,300 sq. ft.
Grate surface	32.5 sq. ft.
Ratio of heating to grate surface	40
Working pressure....	200 lbs. per sq. in.

DODGE TRANSMISSION MACHINERY.

The Dodge Mfg. Co., Toronto, are filling some large contracts at the present time, including a complete machinery equipment for the C.P.R. million bushel grain elevator at Victoria Harbor. The contract covers over 400 tons of iron work. Several carloads of this have been delivered and the rest is nearing completion in the shops.

Reproduced on the page opposite are three views of a large pulley recently completed in the Dodge shops, for a continuous rope drive, in one of the mines in British Columbia. Fig. 1 shows the 20-ft. wheel on the boring mill. The man on the centre will give an idea of the size of the wheel. An extension arm is used in boring large pulleys, and was used in this case.

Fig. 2 shows half of the same pulley with a number of men from the works. This gives a good idea of the size of the pulley. Fig. 3 shows the 20' rope wheel on the balancing ways.

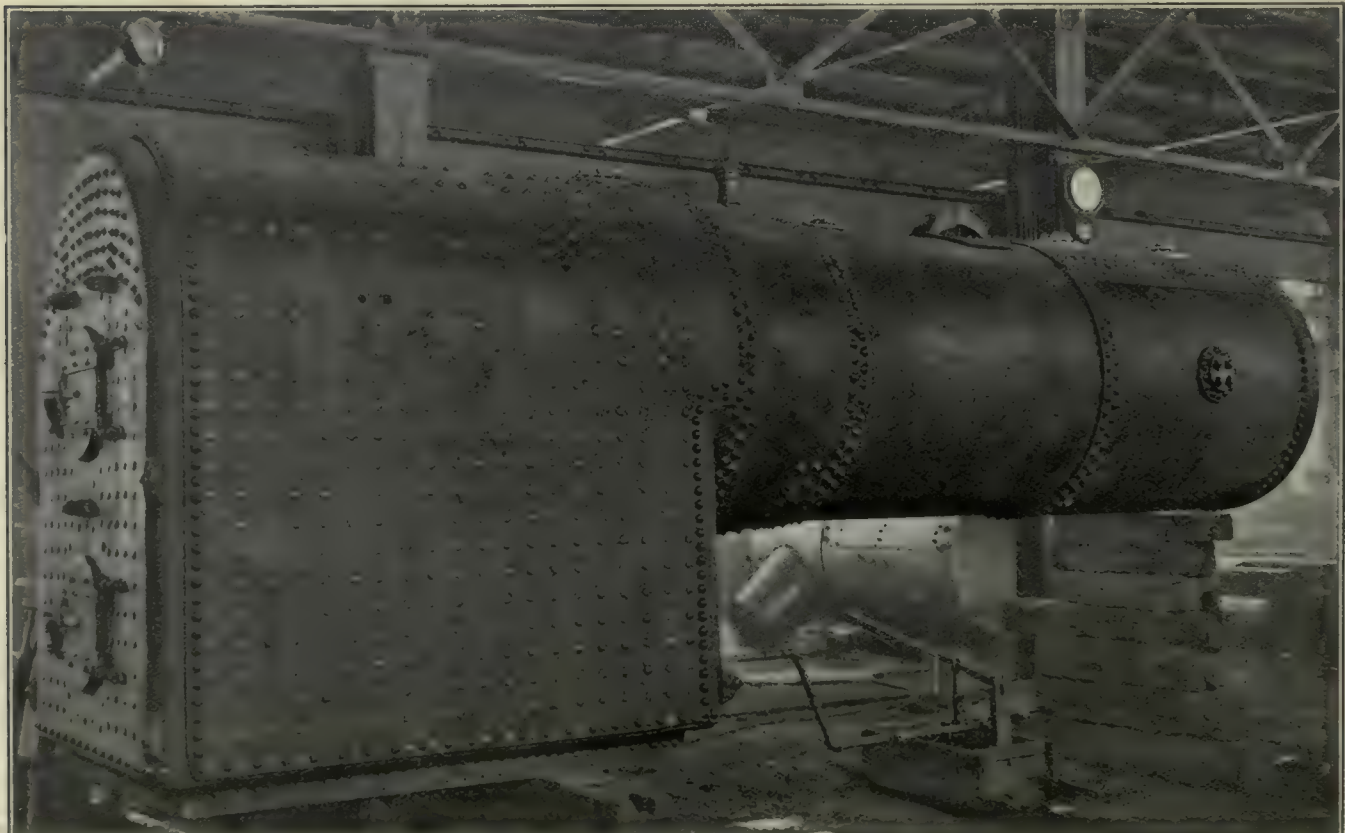

Heavy Locomotive Type Marine Boiler, Goldie & McCulloch Co., Galt.

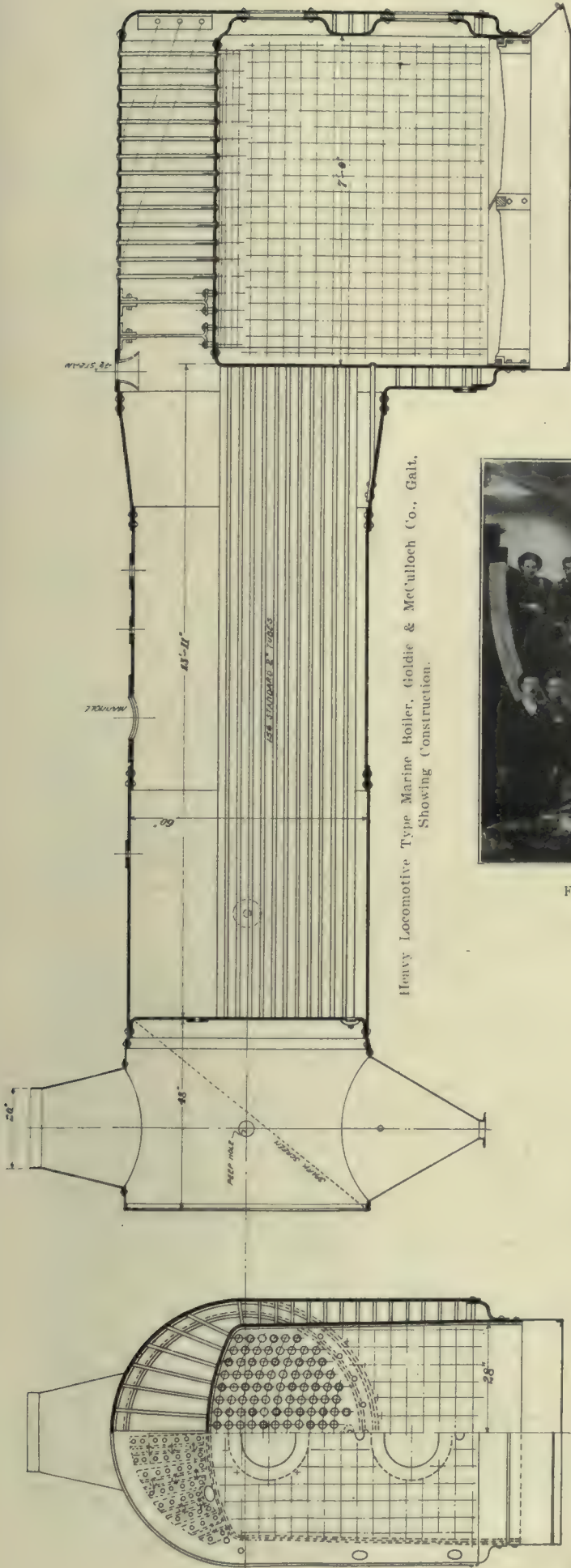

Fig. 1.—Machining 20' Rope Wheel.



Fig. 2.—View Giving an Idea of the Size of the Pulley.



Fig. 3.—20' Rope Wheel.

CANADIAN MACHINERY

AND MANUFACTURING NEWS

A monthly newspaper devoted to machinery and manufacturing interests mechanical and electrical trades, the foundry, technical progress, construction and improvement, and to all uses of power developed from steam, gas, electricity, compressed air and water in Canada.

The MacLean Publishing Co., Limited

JOHN BAYNE MACLEAN, President W. L. EDMONDS, Vice-President
 H. V. TYRRELL, Toronto Business Manager
 G. C. KEITH, M.E., B.Sc., Toronto Managing Editor
 F. C. D. WILKES, B.Sc., Montreal Associate Editor

OFFICES:

CANADA

MONTREAL Rooms 701-702 Eastern Townships Bank Bldg
 TORONTO 10 Front Street East
 Phone Main 2701

WINNIPEG, 511 Union Bank Building
 Phone 3726

BRITISH COLUMBIA - Vancouver
 F. R. Munro
 H. Hodgson,
 Room 21, Hartney Chambers

GREAT BRITAIN

LONDON 88 Fleet Street, E.C.
 Phone Central 12960
 J. Meredith McKim

UNITED STATES

NEW YORK R. B. Huestis
 1109-1111 Lawyers' Title, Insurance and Trust Building
 Phone, 1111 Cortlandt

FRANCE

PARIS John F. Jones & Co.,
 31bis, Faubourg Montmartre,
 Paris, France

SWITZERLAND

ZURICH Louis Wol
 Orell Fussli & Co

Cable Address:

Macpubco, Toronto. Atabek, London, Eng.

SUBSCRIPTION RATE.

Canada, United States, \$1.00. Great Britain, Australia and other colonies 4s. 6d., per year; other countries, \$1.50. Advertising rates on request.

Subscribers who are not receiving their paper regularly will confer a favor on us by letting us know. We should be notified at once of any change in address, giving both old and new.

Vol. VI.

February, 1910

No. 2

A CHAT WITH THE EDITOR.

We, the editors of Canadian Machinery, would very much like to have a ten-minute chat with each and every one of our readers at least twice a year. We want to do this because we want you to get confidential and tell us how you like the paper, what you would criticize about it, etc. It is in this way, and, we believe, only in this way, that we can make Canadian Machinery of greatest use to you.

The trouble is that if each of you were to pass through our office, stopping only for ten minutes, it would take over four months to go from A to Z, and in the meantime where would Canadian Machinery be? So what we want you to do is to sit down some evening when you have ten or fifteen minutes to spare and write us a letter containing your views, criticisms, etc. Call us down, if you think we need it. It will probably do us both good—you, to get it out of your system, and us, to have our weak spots shown up. Sometimes, you know, editors like us are apt to get the idea that our paper is just about perfect, when in reality there is loads of room for improvement. We will admit that we do think Canadian Machinery IS a pretty good paper for its field, but it can be made much better and we want your help.

If you don't want your letter published, say so, and that settles THAT question. If you have any ideas about machine shop and foundry management, labor-saving dodges, jigs, systems, etc., tell us about them, because we pay real money for those sort of letters.

Another thing: If you are interested in any line of machinery, write to Canadian Machinery advertisers and get their catalogues. They will be glad to send them if you mention Canadian Machinery, and a good library of up-to-date catalogues is a mighty good thing to have. They generally contain a fund of useful information that

every man connected with a machine shop should have. It's cheap information, too—only a two-cent stamp and a few minutes' time per catalogue.

But, whatever you do, we want you to write to us about Canadian Machinery. We are making a frank confession to you, that we are aware of the room for improvement, and we reiterate: we want your co-operation. After all, it is the readers' co-operation that makes or breaks a paper. You pay for the publishing indirectly, because you make it pay the advertisers to use our columns, and therein is the paper's revenue. So, you see, we are anxious to "get in right" with you, and the only way for us to know when we have reached this stage is to have you tell us (without gloves on) when and how we are in wrong. Won't you?

AN ANTI-COMBINE BILL.

Readers will be interested in the bill introduced in Parliament this week by Hon. Mackenzie King with the object of preventing the formation and continuance of organizations controlling the market on any commodity in a monopolistic manner.

It is proposed that any six persons who believe that a combine exists may send a request for an investigation. The judge then orders a hearing, and if he finds that there is a prima facie case, he may direct an investigation to be made through the machinery provided by the Act. The Board of Investigation will consist of three members, one to be appointed on the recommendation of the complainants, another on the recommendation of the defendants, and the third by these two. If it is found that an unfair combination exists, the duty upon the article concerned may be removed or decreased, or a fine of a thousand dollars a day may be imposed.

Provision is also made that in case the owner or holder of a patent makes use of the exclusive rights he controls so as to unduly limit the manufacture or supply of such article in a manner to injure trade or commerce such patents shall be liable to be revoked.

Weakness of Bill.

Every fair-minded man, every business man and every student of economics recognizes that one of the conditions of modern business methods is the development of mergers and combinations; in other words of agreements between various classes of mercantile enterprises.

Some combinations are no doubt based on illegitimate grounds. Their sole aim is to bleed the public. But they are not all of this type. On the contrary we believe the majority of these mergers or agreements are not only based on sound business principles, but on sound moral principles as well. They are merely created with a view to rectifying evils or curtailing cost of doing business.

But as the law now stands the legitimate merger, combination, agreement, or whatever we may choose to call it, is subject to irritating, costly and unjust legal proceedings. This ought not to be, and could easily be obviated if the Government would provide proper safeguards which would at the same time protect the public as well as the members of the combinations which were legally and morally sound.

It appears to us that the most simple way of doing this would be for the Government to create a permanent board similar to that of the Railway Commission, which is doing such good work in the interests of the shippers and traveling public of the country. This board could make a tentative examination of any charges made, and if a prima facie case was made out take such steps as

would lead to a thorough investigation and the punishment of the parties if found guilty.

No one denies to-day the right of labor to combine for legitimate purposes. No one would probably deny that in theory business men enjoy the same right. But in practice they do not enjoy the same right. Whenever and whenever business men combine, merge, or organize in any way the fact is heralded by the daily press as a menace to the public welfare, and the authorities are forced to prosecute and the members of the combination to protect themselves in a costly, and usually long-pending suit, whether they are innocent or guilty.

A permanent board such as suggested would protect the public, and at the same time prevent pernicious and unjust prosecutions of business men, whose organizations are founded upon equity and justice.

The weakness of the bill now before the House of Commons, is that it does not provide for this much needed machinery.

◆

ILLEGITIMATE SALESMANSHIP.

In spite of the rigorous provisions of the Secret Commissions Act, which prohibits the giving of secret rebates and commissions, there are still some salesmen who in their desire to get business are resorting to practices which are forbidden by the Act.

Our attention is frequently drawn to flagrant breaches of the Act and one of the most common practices in this regard appears to be the passing from the pocket of the salesman to the palm of the customer a sum of money sufficient to induce the latter to place an order for goods on which there is a fixed selling price.

Aside altogether from the moral aspect of such practices they are proofs of poor rather than good salesmanship. When a salesman resorts to secret rebates and other dishonest practices in order to secure business it is an acknowledgement of his own inefficiency to sell goods in the ordinary way.

The true salesman is he who relies upon the merits of his goods, plus his own personality, to effect sales; not he who is so unwise as to run the risk of incurring severe legal penalties in order to accomplish that which he cannot do by legitimate means.

One thing that perhaps can be said in favor of the salesman who is ready to break the law in order to effect a sale is that he is at least courageous in view of the fact that he is running the risk of a maximum penalty of a \$2,500 fine or two years' imprisonment.

Those who have to substitute crookedness for efficiency should either learn the secret of true salesmanship or embark in some vocation in which dishonesty rules all actions.

Some day somebody will be caught, when there will be waiting and gnashing of teeth.

◆

MACHINE SHOP MANAGEMENT.

Those who have watched the development of the machine shop cannot fail to be struck with the great improvement in the present day shops over those of only a few years ago. Improvements in mechanism have kept pace with improvements in systems, factories are better designed, they are more fireproof, cost systems have been installed, work is handled with greater facility by means of cranes, tracks, etc., and perhaps better than all these is the fact that the near sighted policies of dealing with men are being eliminated and forgotten, and mechanics are being taught to stand on their own feet. Instead of

the "old man" glowering around to see where he can find fault, there is the utmost harmony between mechanics, foremen, superintendent and proprietor.

The system that leads to this harmonious end should be encouraged. Trusting the men will go a long way towards harmonious relationships. The benefit societies installed in many shops, the rest and recreation rooms, the educational systems, first aid to injured, etc., are developments in factory system and management which cannot help but draw out the best in every conscientious workmen.

The forman or superintendent of a few years ago, who ruled by fear would look in wonder at the machine shop of to-day where the superintendent, foremen and workmen are all friends. The care of the workmen is an important feature in machine shop management which, with the educational features, has united the managers and workmen better than any forcible means could ever accomplish. In this issue is described the system of First Aid in the Angus Shops, Montreal. This system can be applied to any shop where the management and workmen co-operate.

One thing that the machine shop management, except in a few cases, have neglected is the protection of machinery. Canadian Machinery has, in almost every issue, brought to the notice of managers, superintendents, foremen and other readers, the necessity of protecting machinery. We are rewarded by many methods being adopted—cages are used to protect belting, floor countershafts are being boarded over and other means are being used. There is still a large field for improvement along this line.

Other things, if adopted, will also increase the efficiency of the shop. Toilet rooms, tool rooms and store rooms are often arranged at great distances. To concentrate these, toilet rooms should be arranged so that the men will not lose time by walking unnecessary distances. Tool rooms and store rooms have been concentrated in some shops by using boys to deliver tools, etc., thus saving the time of expensive men. In this case a private telephone exchange is necessary. It can be computed in dollars and cents, the loss of time caused by the average man to walk one hundred yards and return. The management should not keep their view concentrated on direct expenses, but the indirect expenses should receive attention. A close following up of these items will greatly increase the efficiency of the workmen and largely increase the output of the shops, even more than at the present time.

◆

NOTES OF THE MONTH.

The French Treaty has been ratified by both the French and Canadian governments and will shortly become operative.

• • •

The people of Toronto recognize the value to Canada of the Canadian National Exhibition, and have voted \$320,000 to provide new buildings, and other improvements at the Fair. These will be completed during the next three years and will include: Live Stock Arena, \$110,000; Machinery Hall, \$75,000; Women's Building, \$60,000; Poultry Building, \$30,000; Dog Building, \$25,000; Lavatory accommodation, \$20,000; Women's rest building, \$7,000; Band Stand, \$350. It is sincerely hoped that the new Machinery Hall, which will be one of the most educative features of the Exhibition, will be started at once.

DEVELOPMENTS IN MACHINERY

New Machinery for Machine Shop, Foundry, Pattern Shop, Planing Mill; New Engines, Boilers, Electrical Machinery, Transmission Devices.

UNIVERSAL DIVIDING HEAD.

The Universal Dividing Head is perhaps the most delicate and important mechanism connected with the milling machine. It is subjected to frequent and varied use, and the work done by it must, as a rule, be thoroughly accurate. The ideal dividing head therefore must be essentially accurate; must be of such construction as best to preserve that accuracy, both by its rigid-

ism. Large diameter worm wheel is essential to the best work. On this dividing head the worm wheel is mounted centrally inside the head block, between the front and rear spindle bearings. It is keyed and pressed to spindle, insuring positive movement to spindle when engaged by worm. The worm is located at an angle, the worm shaft being at an angle of 36 degrees from the horizontal. This brings the

inch swing head, and 6½ inch diameter on the 13¼ inch swing head.

The worm is in one piece with the worm shaft which runs in a long and liberal bearing. This bearing extends up to the shoulder formed by the worm proper, and consequently affords strong bearing support close to the point of mesh. The worm runs constantly in oil. The wear between the worm and worm wheel is very easily taken up through outside adjusting screw shown. This adjustment is in a straight line, perpendicular to the axis of the worm wheel, and thus preserves the alignment and accuracy in repeated adjustments. The worm is easily disengaged from the worm wheel for quick index through worm wheel direct. This is through means entirely independent of its adjustment, which therefore is not disturbed. Another advantage is that, in the common necessity of tightening the nut on arbors which have been put in the spindle, the strain is relieved from the worm wheel teeth.

The index plunger is mounted on the worm shaft, therefore indexing directly to the worm wheel, leaving no chance for error or inaccuracy. The fact that the worm shaft is set at an angle as already described, likewise locates the index plate at an angle from the vertical. This makes it easy for the operator to read in indexing, because it is directly in his line of vision in his natural operating position. Two index plates are regularly furnished, providing all division changes up to 60, all even numbers and multiples of 5, up to 120, and a very liberal number of division changes between 120 and 400. Three special high number index plates can be furnished, which provide 122 additional division changes between 61 and 400.

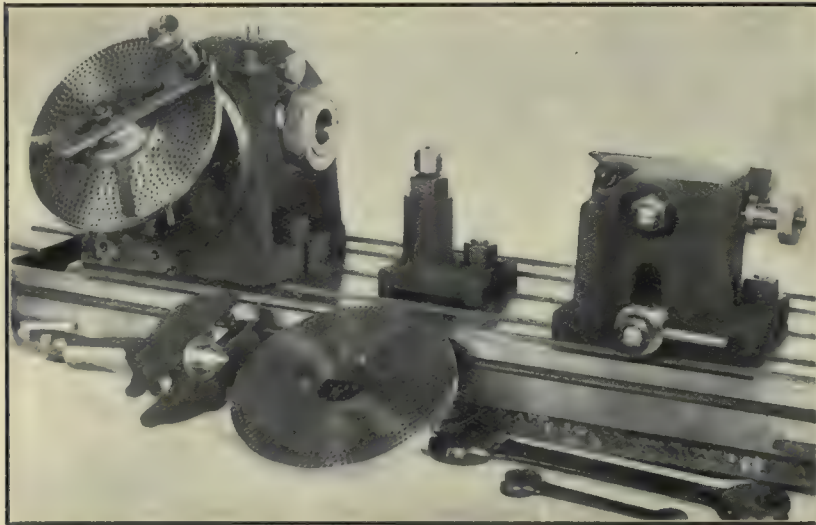

Fig. 1.—Kempsmith New Style Universal Dividing Head.

ity and by its method of adjustment; must be compact and convenient, and universal in its scope. In their new and improved Universal Dividing Head, the Kempsmith Mfg. Co., Milwaukee, Wis., have embodied these considerations in a marked degree. Its substantial and compact construction is well indicated by Fig. 1.

The most important feature of the dividing head is the dividing mechan-

point of mesh of worm with worm wheel correspondingly around to an angle from the vertical. This makes it possible to utilize a great deal of extra space for the worm wheel, otherwise occupied necessarily by the worm, when located directly over or under the worm wheel. The result is that the worm wheel can be made extremely large in proportion to the size of the head—5¼ inches diameter on the 10½

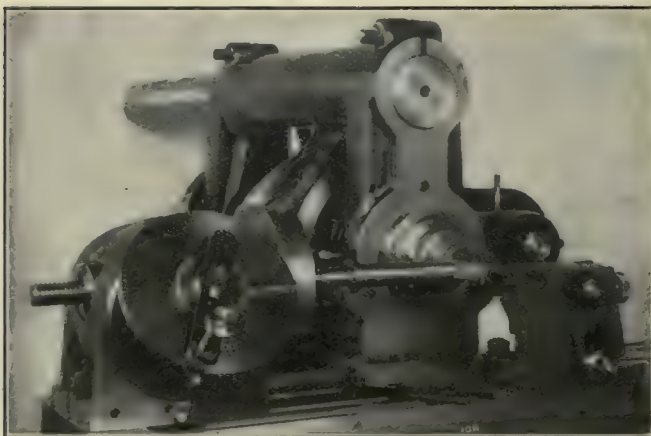

Fig. 2.—Head Showing Work Passed Through Spindle.

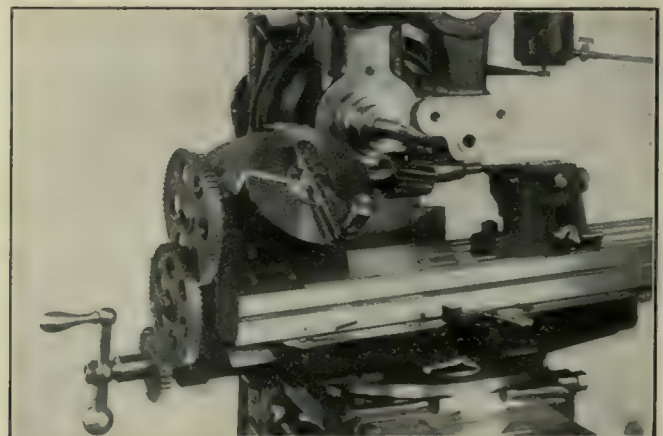

Fig. 3.—Head Arranged for Cutting Ordinary Spiral.

including all divisions up to 200, not obtained through the standard index plates. This fact of the index plate being at an angle will also permit of still larger plates being mounted in extremely special individual instances without requiring increase in the swing of the dividing head.

Direct indexing is easily accomplished with worm and worm wheel disengaged. The plunger engages the circle of holes in the front of the worm wheel. The spindle is graduated to correspond, on the front shoulder.

The spindle is large with liberal taper bearings, and has a simple and powerful locking device, and is furnished with the same size taper hole and threaded nose as on the main spindle of the universal millers on which the head is regularly furnished, making all tools interchangeable, has a large hole run-

the worm is driven direct from the change gear shaft. Fig. 3 shows the dividing head set up with a train of change gears in the usual manner for cutting an ordinary spiral, the job shown being a standard spiral milling cutter 3 inch diameter, 18 teeth, with 48-inch lead of the spiral. On this dividing head a very interesting departure is provided for short leads, by which the gear train is led direct from lead-screw to the dividing head spindle, an extension stud being provided on the spindle as already described. This is shown in Fig. 4, and this also shows the use of the Universal Milling Attachment where the angle between cutter and work is greater than can be obtained through the swivel table. In the charts which accompany this dividing head, data is given for leads from .120 to 1½ inches through gearing direct, and

top. This allows the use of large diameter shank or end milling cutters in squaring shafts, and similar work, as shown in Fig. 2. The centre is firmly fixed in the tailstock and has rapid and easy adjustment. It can be elevated by rack and pinion for milling tapers, and can be tilted and clamped into alignment with the work. This Universal Dividing Head is furnished in two sizes, to swing 10½ and 13¼ inches.

CAMSHAFT GRINDER.

The camshaft of an automobile or marine engine is an all essential factor. Its cams, differing in angle one from another, must be exact of form and exact of angle. The desirability of having them made in one piece with their shaft is evident. For grinding the cam forms on a camshaft The Norton Grinding Co., Worcester, Mass., has develop-

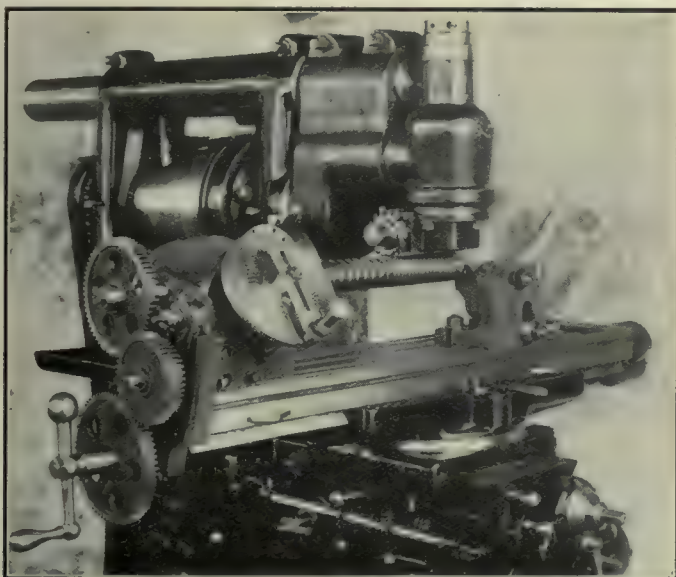

Fig. 4.—Short Lead; the Gear Train is Led Direct from Lead Screw.

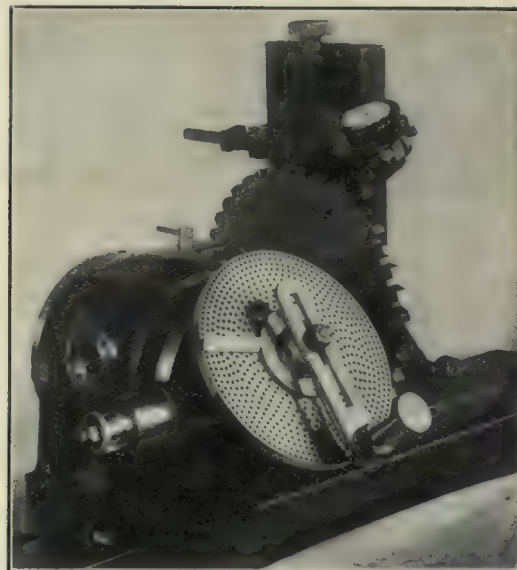

Fig. 5.—Testing Accuracy of Worm Teeth.

ing through, an idea of which can be gathered from Fig. 2, which shows the work passed through the spindle. The rear end of the spindle is arranged to receive an extension stud for use in gearing direct from the lead-screw to the spindle for cutting fine leads as described later. The rotating block carrying the spindle swings through an arc of 150 degrees, from 10 degrees below the horizontal to 50 degrees beyond the perpendicular. It is powerfully clamped in a horizontal or vertical or angular position by two bolts. These bolts clamp the whole surface of flanges around the periphery at both front and rear sides of the head.

This dividing head is furnished with a series of 12 change gears for spiral milling. The change gear bracket is very easily attached or removed. The mitre gear on this meshes with the mitre gear attached to the index plate;

for leads from 1.550 to 100 inches for gearing through the worm.

Fig. 5 shows a method employed in testing the accuracy of the worm wheel in every tooth. The master plate is mounted in the spindle and has 40 perfect divisions. It is therefore possible to test the relative and cumulative error for the teeth individually. The maximum relative error allowed is .0005 on the master plate, and the maximum cumulative error at any point is .002 on the master plate. The average is less than half of this. The master plate is 11 inch diameter, and worm wheel 5¼ inch diameter, consequently errors on the master plate are correspondingly reduced on the worm wheel proper.

The tailstock is of the side centre type. The centre is set into the tailstock at an angle, bringing the centre within ¼-inch of inner side of the tail-

ed an attachment to be used on its standard type of machine.

The fixture, as may be seen in Fig. 1, is fastened on the machine in the same manner as the head and tailstock and is arranged to have a rocking motion, that the line of the cam form may be followed in the grinding. The work is mounted on centres and is held by a special dogging device, the dog being held tight between two pins on a face plate. The end of the work is splined and keyed into the dog, so that exact alignment is maintained, until the last operation, the grinding of the last cam completed. Upon the shaft of the attachment, in which is the head centre, is mounted a group of master cams, corresponding in number and form and angle to the cams to be ground. This shaft is driven by gears from the main driving plate of the machine. Fastened to the table, like a back rest, is a

bracket which carries a rod upon which slides a roll carrier. The rod is drilled to receive a pin in the roll carrier, there being a pin position to bring the roll opposite each of the master cams. The cam is held against the roll by spring pressure. This is accomplished

wheel mounted in a fixture. This wheel takes the place of the roll and is in the same relative position that the roll occupies to the master cams during the grinding of camshafts, and in the final operation is sized to micrometer to the exact size that the roll will be. Con-

the regular type is that it is equipped with an adjustable collar provided with integral keys, which slide in longitudinal keyways in the arbor. The arbor is also threaded for a short distance to receive an adjusting nut, which bears on the

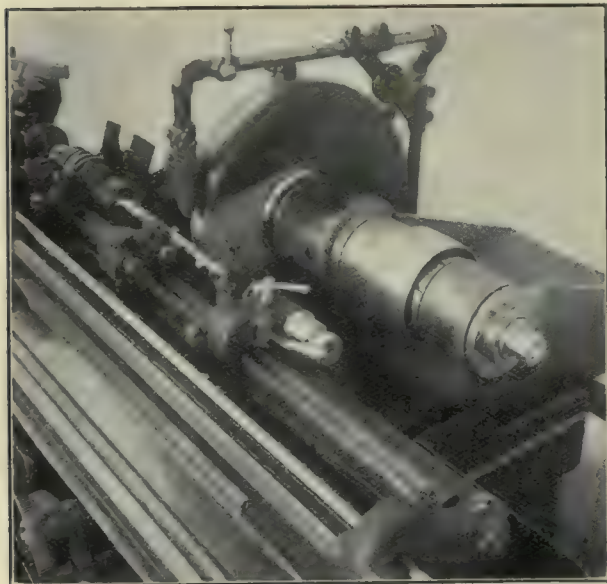

Fig. 1.—Cam Grinding Attachment.

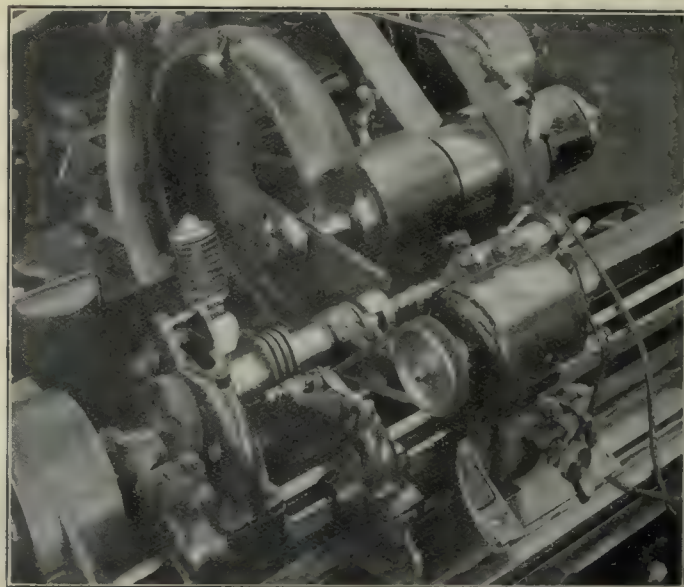

Fig. 2.—Grinder Arranged for Grinding Master Cams.

by a spring plunger, consisting of a heavy casing with a plunger backed by a powerful spring, which is always acting to keep the master cam in full contact with the roller. As the roller is fixed in position the camshaft is constrained to oscillate as it rotates in definite relation to the form of the master cam. In doing the work the

sequently the conditions attending the grinding of the master cams are identical with those which exist when these cams are employed in commercial work, and a corresponding degree of reliance may be placed upon the accuracy of the product. Fig. 3 shows a typical solid crankshaft ground with this attachment.

collar. The collar engages the shell reamers in the usual way.

Perhaps the chief advantage of the new arbor is the quickness and ease with which it releases the shell tool, no matter how tightly it may have become jammed on the arbor; a turn or two of the adjusting nut does the trick, with no necessity for removing the arbor from the spindle, and no excuse for the vise and hammer methods which often cause considerable damage.

Another decided advantage is the fact that the collar can always be set so as to allow the shell tool to fit snugly on the arbor, and yet fully engage with its slots the collar keys.



Fig. 3.—A Solid Crankshaft Ground in the Cam Shaft Grinder

roll is pinned in position against the first master cam, and the grinding continues until the first cam of the work has been finished. The roller then passes to its second position and the second cam to the grinding wheel, and so on until the shaft is completed.

The master cams themselves are produced in much the same manner, a model cam being used to give the required form. The group of blanks is mounted in the attachment, as shown in Fig. 2. A stationary steel arc of the same radius as the grinding wheel takes its place and is maintained in contact with the model cam which for the time being is the master. Spring pressure is applied to accomplish this function, but the plunger is arranged to act in the reverse direction. The grinding of the master cam blanks is done by a small

RELEASING ARBOR.

The Cleveland Twist Drill Co., Cleveland, has secured the patents and is about to place on the market a new arbor for

A. S. Herbert, manager of Canadian branch of Siemens Bros., Dynamo Works,

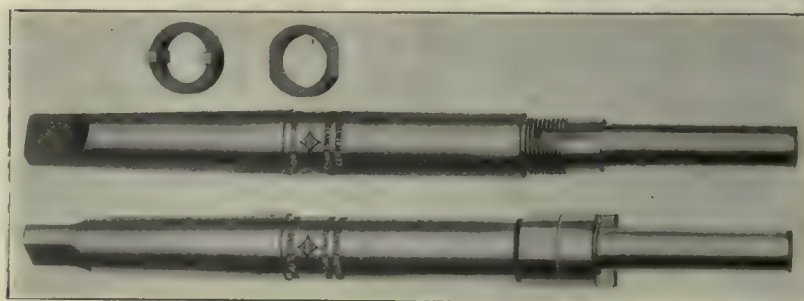

Patent Releasing Arbor of Cleveland Twist Drill Co.

shell tools. As is indicated in the accompanying illustration, the essential difference between this patent arbor and

Stafford, England, sailed for England on Jan. 6, and will spend about two months in the Old Country.

LARGE DOUBLE-DOUBLE-CRANK PRESS.

The E. W. Bliss Co., 20 Adams Street, Brooklyn, N.Y., have recently designed and built a large double-double-crank press, shown in the accompanying illustration. The large machine is of the double-crank type, of a special design, being in reality a double-double-crank press. The machine is especially adapted for the operation of very long and narrow dies, for punching, forming, piercing, bending and similar operations which require great pressure. It embodies certain improvements in detail which adapt it to the special work it has to do. The machine, which is double-g geared, is driven by power friction clutch located on the driving shaft, which clutch is engaged and disengaged by means of the treadle running along the entire front of the press; the treadle being connected by treadle levers with a treadle shaft located at the rear of the press, to which is attached the counter weights and con-

and weight is the adjustment of the slide. In the press shown, this is taken off in a very effective and simple way by a chain drive—the chains running from the shafts carrying the adjusting bevel pinions back to a small driving

quickly doing what would otherwise be slow and laborious work, insures the perfect alignment of the slide in relation to the bed. By shifting the lever to the right, the slide is raised, and by shifting to the left it is lowered.

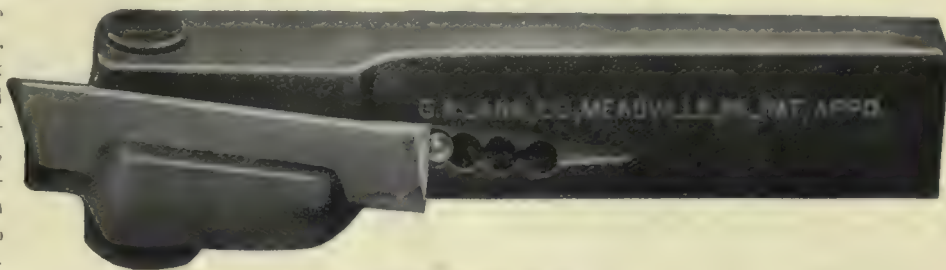

Lang's New Tool Holder.

shaft, which runs the entire width of the press. This shaft which derives its power by means of a belt from the main driving shaft, is fitted with two friction clutches. In order to raise or lower the slide, it is only necessary for the operator to shift the lever located above the slide

LANG'S NEW TOOL HOLDER.

The principal feature of advantage claimed for Lang's new tool holder is that it will take a much heavier cut than is possible with the ordinary tool holder. The cutter is of triangular section, and is held rigid in the "V" slot, which insures a perfect fit between the cutter and holder. It is also backed up clear to the cutting end with a support which prevents the cutter from springing down or back away from the work.

The tools are made in right and left hand and are intended to be used exactly as the solid forged tool. One of the great disadvantages heretofore in using an inserted cutter of this kind has been the tendency of the cutter to slip back in the holder. This is especially noticeable on heavy, long cuts. This fault has been overcome in this holder by the in-

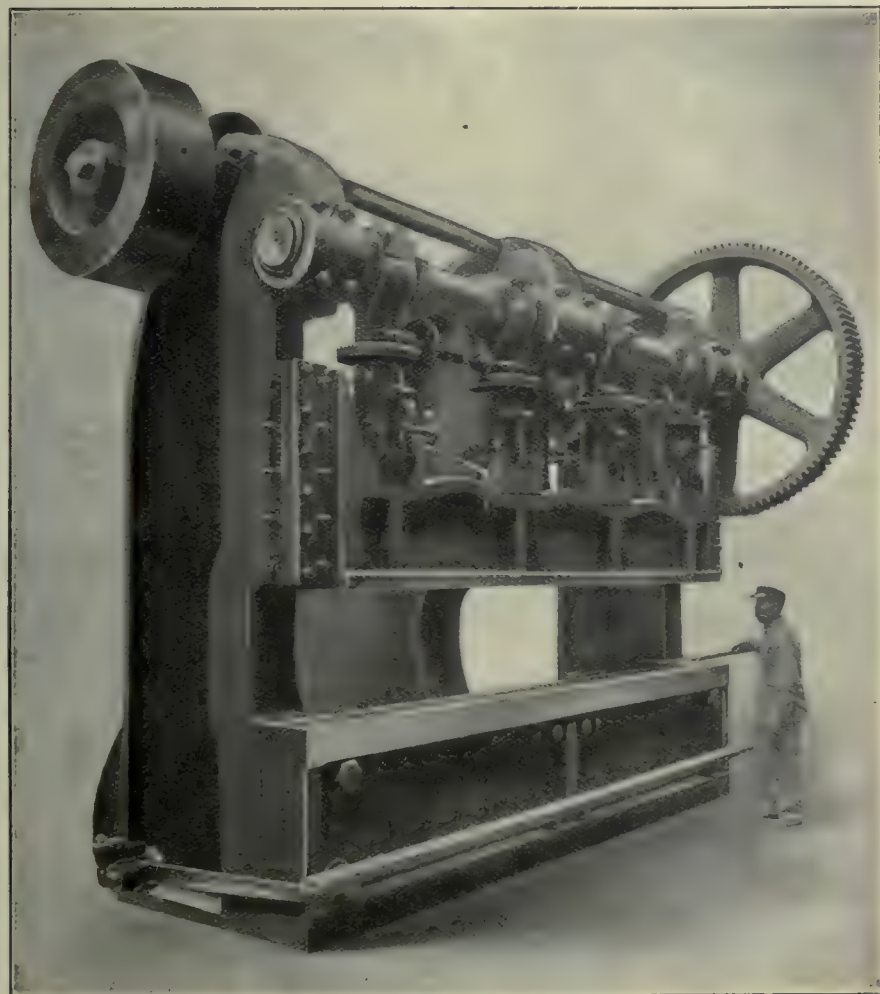

Bliss Large Double-Double Crank Press.



Lang's New Tool Holder.

sertion of an ordinary steel ball at the rear of the cutter. These balls are advanced from pocket to pocket as the end of the cutter is worn away and moved forward. The pockets are connected together by a slot as shown, and when the cutter is loosened, the balls are easily changed from one pocket to the other but after the cutter is back in position, it is impossible for the ball to drop out, as the cutter hits it above the center, forcing it against the bottom of the pocket where the entire thrust is taken. This positive stop is not intended to be used on ordinary work, as the clamping bolt holds the cutter sufficiently tight for all ordinary purposes for which tool holders are usually used. These holders are manufactured by G. R. Lang Co., Meadville, Pa.

nections which operate directly upon the clutch.

In the construction of large presses of the double-crank type, an important consideration on account of alignment

between the two cranks at the left-hand side of the press, which engages the clutch which operates the chain drive. This, in turn, operates the four adjusting screws in unison, and in addition to

FOUNDRY PRACTICE AND EQUIPMENT

Practical Articles for Canadian Foundrymen and Pattern Makers, and
News of Foundrymen's and Allied Associations. Contributions Invited.

DETROIT CONVENTION.

The convention in Detroit, June 6-10, promises to be a greater success than ever. The American Foundrymen's Association, the American Brass Association and the Foundry and Manufacturers' Supply Association have well organized local committees for making the convention a success.

From present indications the Supply Men will use twice the space used at the previous events to house the exhibits, and it is urged that all who intend to exhibit complete their plans at an early date and at the same time inform Secretary C. E. Hoyt as to the amount of space they desire, etc. The permanent buildings will have concrete floors on the ground level, and exhibits requiring foundations and pits will have to be placed in the temporary buildings. The main building space will not be laid out or temporary building plans made until information is received concerning members' requirements. The cost of space will be 50 cents per square foot. The Cadillac hotel has been chosen as headquarters for the Foundry and Manufacturers' Supply Associations.

The following are the secretaries: Dr. Richard Moldenke, Watching, N.J., American Foundrymen's Association; W. M. Corse, Detroit, American Brass Founders' Association; C. E. Hoyt, Chicago, American Foundry Foremen, and Foundry and Manufacturers' Supply Association.

HANDY OFFICE RULE.

The Dominion Foundry Supply Co., Montreal and Toronto, are remembering their friends with a handy and useful souvenir in the shape of a fifteen inch office rule. On the front in addition to the name are the words, "Everything you need in the Foundry." On the reverse side is a list of the wide range of equipment carried by the Dominion Foundry Supply Co.

HANDSOME CALENDAR.

The Hamilton Facing Mill Co., foundry outfitters, Hamilton, remembered their customers on Christmas with one of the handsomest calendars yet issued for advertising purposes. It is a reproduction of that beautiful home scene of Albert Herter, "Just a Song at Twilight." The effect of the light from the fireplace is very marked, it greatly increasing the romantic, twilight sentiment of the

scene. The lady is at the piano, her face veiled in shadow, while the meditative features of the father and the face of the sleeping child are illumined by the firelight, the whole effect being one of soft peacefulness and solemn joy. The managers of the Hamilton Facing Mill Co. are to be congratulated on their aesthetic taste.

TABOR SHOCKLESS JARRING MACHINE.

Jarring machines have been steadily growing in favor for the last five or six years, prior to which, this method of ramming sand, although not new by

ramming sand, and the development of the jarring machine has been correspondingly rapid, until to-day it is recognized as a most practicable method of ramming large bodies of sand by power. It is probably safe to say that ten years ago no one would have thought of a jarring machine for molds any larger than those used on a power squeezer which one or two men could handle, but it has since been found that large molds can be rammed as readily as small ones and to-day it is not uncommon to hear of jarring machines capable of ramming molds weighing ten to twenty tons. But with this increase in capacity has come the very serious complaint of damage due to foundation shocks when such heavy masses fall upon their anvil. These shocks are destructive to molds set up in the neighborhood of the machine and the ground waves sometimes travel far enough to cause serious annoyance in other departments of a manufacturing plant. Chemists complain that they can not use their sensitive balances while the jarring machine is running and the efficiency of offices and drawing rooms is impaired by the distracting and disturbing influence of the jarring machine near by.

The present machine has therefore been designed to eliminate these objectionable foundation shocks and to put upon the market a jarring machine which can be used in any position and under any conditions where an ordinary power squeezer would be practicable. Even in brass foundries on the upper floors of high buildings it is practical to instal a Tabor Shockless Jarring Machine if the building is strong enough to carry its weight.

To demonstrate this fact a small machine with 8 inch jarring cylinder has been built by The Tabor Mfg. Co. and the illustrations herewith are made from photographs of this machine, except the sectional view which has been taken from the design for a twenty-five ton machine on order.

Fig. 1 shows the machine as it appears ready to instal. Fig. 2 shows the same machine set up in a pit made to receive it with linkage connecting the operating valve on the machine to the operating levers as conveniently arranged near the jarring table.

Fig. 3 shows in section the jarring table the anvil cylinder and a simpler arrangement of connections to the operating valve than it was possible to

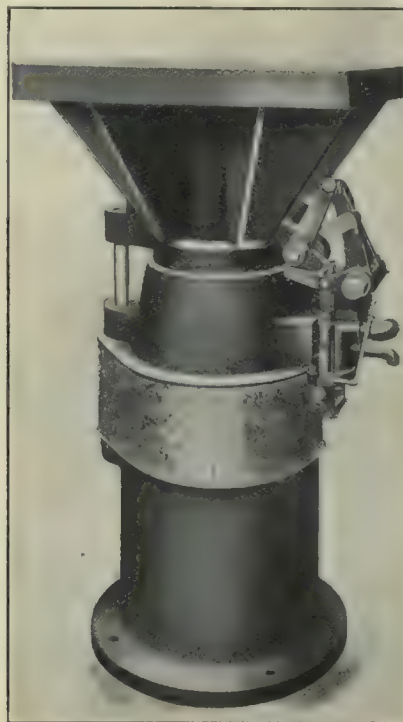

Fig.1.—Tabor Shockless Jarring Machine.

any means, was not recognized or appreciated beyond a very limited field. Like many other good things which have not been pushed commercially or advertised extensively, the jarring machine has had a long period of repose since its original conception by Hainsworth in 1869. Improvements were made from time to time by various inventors, notably by Jarvis Adams in 1878, but the machines were not exploited and were confined in their use chiefly to the foundries controlled or operated by their inventors.

In the last decade, however, the public has gradually awakened to the advantages possessed by this method of

improvise for the photograph from which Fig. 2 was made.

Fig. 4 shows the bell cranks controlling the variable stroke of the jarring table and the automatic cut-off of the piston valve. This valve is of the differential pressure type operated by constant and intermittent pressure through the pilot valve, shown connected by link to bell crank in front of photo. The position of stop which controls length of stroke is designated by an arrow, and is shown in its minimum position, when the latch lever on the operating stand is in the lowest notch. See Fig. 3.

Fig. 5 shows the stop which controls the variable stroke in its maximum position. This machine consists of a

the supporting springs beneath the anvil carry the entire load of anvil, table and mold, and they do this under static conditions and also while the table is rising, but when the table reaches the upward limit of its travel, and when the air is exhausted to let it drop, the anvil is suddenly relieved of the air pressure, which supported the table, and as a natural result the springs beneath the anvil expand and accelerate its upward movement, while the table is falling. As a result, the momentum of the falling table and load is substantially equal to the momentum of the rising anvil at the instant of impact. These momentums neutralize each other, and the table is brought to rest without shock or jar upon any

anvil cylinder while the table is falling. When the operating valve is again shifted to lift the table, the valve is opened to exhaust and the anvil is, therefore, free to drop.

Use of Air.

In this machine attention has been given to the economical use of air and the operating valve is designed to use it expansively in the jarring cylinder as well as to expand it again in the anvil cylinder, thus obtaining the benefit of two expansions. Of course, it is not possible to use the air expansively in the jarring cylinder when the load carried on the table approaches the maximum capacity of the machine, but when the machine is used on lighter loads, full air pressure can be admitted for a

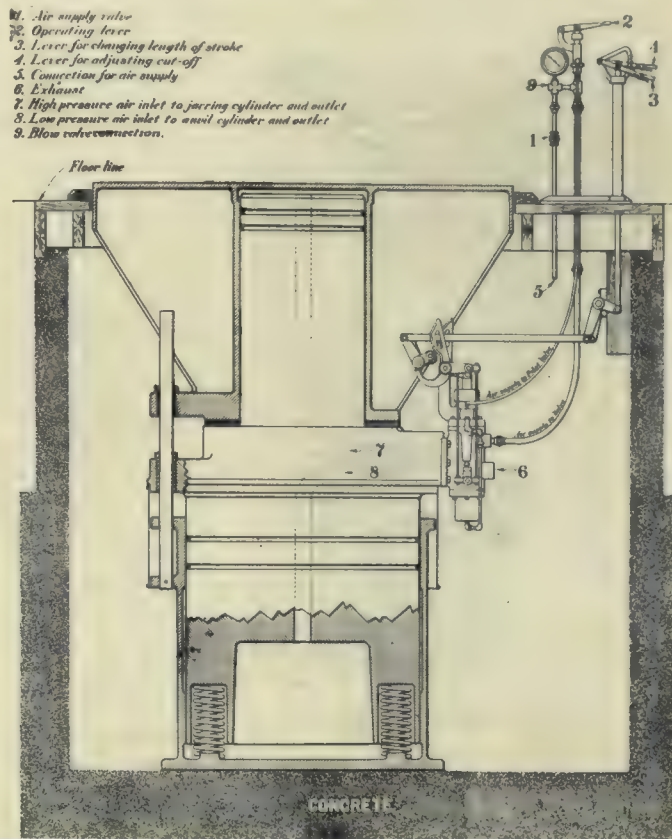
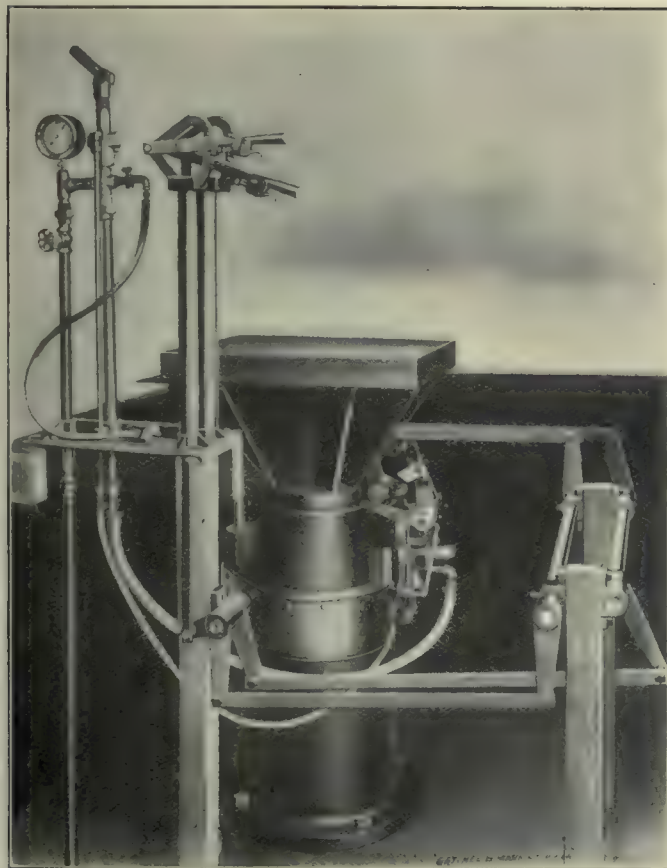

Fig. 2.—Jarring Machine Installed in Pit With Linkage to Operate Levers.

Fig. 3.—Section of Jarring Table, Anvil Cylinder and Connections.

jarring table made in one piece with the cylinder and mounted upon a cylindrical anvil, which in turn is guided by a cylindrical base and rests upon supporting springs calculated to give the anvil a substantial upward velocity while the table is falling.

Foundation Shock Eliminated.

The evil effects of foundation shocks in jarring machines have been recognized and deplored, and various attempts have been made to reduce the amount of shock transmitted to the foundation, but hitherto nothing has been done to effect its complete extinction, which is now accomplished by this machine.

It will be seen from the drawing that

surrounding objects, as completely as if it had dropped upon an anvil of infinite weight. In order to do this the springs beneath the anvil have a very long compression, so that their loss in supporting power, as the anvil rises, will not materially affect its velocity.

Ordinarily, the springs are sufficient to give the desired momentum to the anvil, but in large machines, where the consumption of air is an important item, it is advantageous to utilize the air discharged from the jarring cylinder in augmenting the momentum of the anvil. This is done by making an additional port in the operating valve which connects the jarring cylinder and

short distance and then cut off absolutely and expanded in the cylinder.

When the table reaches its maximum travel, the operating valve is automatically shifted to exhaust, and the air from it may pass directly into the atmosphere, or into the anvil cylinder, if the machine is large enough to make a second expansion worth while.

The cut-off is operated directly through the bell-crank lever acting as an adjustable stop upon an arm attached to the valve stem. The valve is reversed through the action of a pilot valve actuated by a similar bell-crank lever. There are, therefore, two adjustable stops on the table of the machine,

the positions of which are controlled by latch levers on an operating stand.

The cut-off can be adjusted to suit the load carried on the table, and the operating valve can be reversed by the pilot valve when the maximum uplift desired has been reached. It is possible, of course, to substitute compressed air for the supporting springs under the anvil in the simpler type of machine, where no attempt is made to use air expansively from the jarring cylinder to the anvil cylinder.

The use of compressed air to support the anvil necessitates some provision for keeping pressure adjusted to the total load carried, without causing undue variation in the height of the jarring table, as it is more or less loaded, and as air may leak in or out.

The use of long compression springs

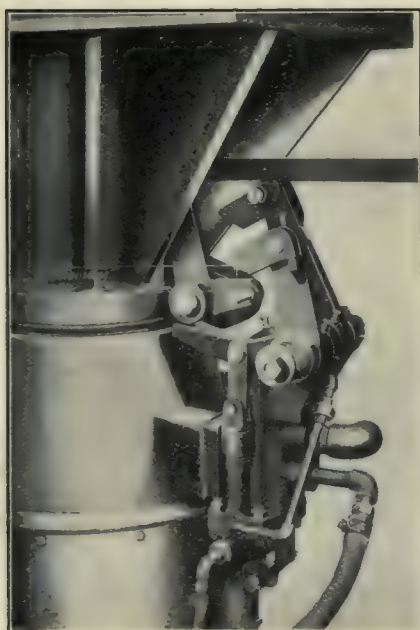

Fig. 4.—Stroke Control and Automatic Cut-off.

somewhat simplifies the construction, and has the further advantage of making it possible to utilize the complete expansion of the air.

The effect of impact between the table and anvil in jar ramming is measured by the change in velocity of the table, and the square of this change in velocity is proportional to the work done upon the sand for any assumed condition of the sand. Of course, the maximum work is done in the first few blows when the sand is loose, and as the operation is continued, the sand becomes more and more firmly compacted together, until finally it acts as one solid mass, and no further work can be done upon it until the severity of the blow has been increased. A short stroke indefinitely repeated will compact sand up to a certain density, a long stroke will compact it to a greater degree of density, and very hard

ramming such as is frequently required in steel foundries, can only be effected by a considerable length of stroke. A variation in the length of stroke from 1 inch to 4 inches is, therefore, provided, depending upon the conditions to be met, and if any case should require more than 4 inches drop, it could easily be provided for in the valve controlling mechanism.

Attention is called to the simplicity of the construction, the enormous strength and stiffness of the cast steel table, ribbed around a central cylinder and acting as a beam of great depth to distribute the central force of impact applied to it equally in all directions.

The anvil is solid, and the blow delivered in this way by impact between two masses having approximately the same momentums, is far more efficient than can be obtained from a table dropping freely upon a stationary anvil.

Parts exposed to wear are protected by sand guards and provision is made for the renewal of such bearings as may in time become more or less worn. The accumulation of sand in the pit cannot affect the operation of the machine until it has attained great depth. At the same time, very little sand can find its way into the pit during the normal operation of the machine, and it will not be necessary to dig out the accumulation of sand very often.

The small machine of this type, weighing about three tons, which has been built and tested, demonstrates that no shock whatever on the foundation is at all perceptible. This machine was mounted upon two 8-inch channel beams in a pit about ten feet wide, the beams resting upon the sides of the pit and the machine resting in the middle of the beams. A man standing or these floor beams, while the machine was running, could not detect any vibration whatever, and although there was necessarily a slight change of load as the table rose and fell, the effect on the floor beams was no greater than it would be for an ordinary power squeezer operating in the usual way.

Ordinarily supporting springs under about 8 inch compression are used to carry the full load and with 4 inch stroke on the table the anvil movement would probably not exceed 2 inches, and ordinarily it would be very much less. The maximum variation in floor load would, therefore, not exceed 25 per cent. of the total load resting on the supporting springs, and this variation is so gradual that it does not partake of the nature of a shock at all. At the moment of impact the supporting springs simply cease to expand and therefore, cease to reduce the load on the foundation. Following this they again compress and gradually increase the load on the foundation by a com-

paratively small percentage of the total load carried.

Ordinarily the shock of impact in the common type of jarring machines, which rest upon a solid foundation, with or without the interposition of cushioning material, is followed by an enormous increase in the foundation load. In one type of machine, the table drops upon an anvil of comparatively little weight, resting upon a wooden crib, which rests in turn upon a concrete block. The momentum of the anvil and table is arrested in a very short distance by the compression of the wooden cribbing, and the foundation load is immediately multiplied many times, perhaps a hundred times the weight of the loaded table.

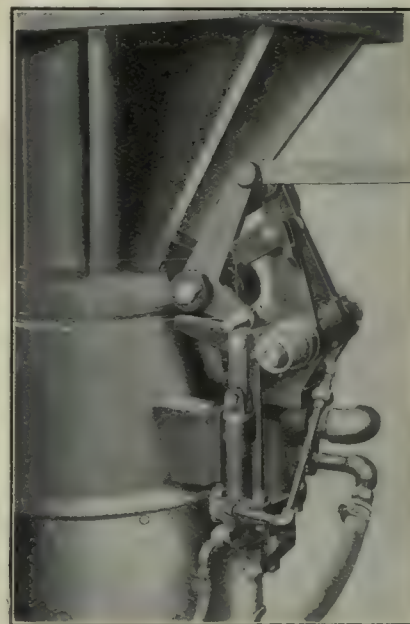

Fig. 5.—Stop of Variable Stroke in Maximum Position.

The Tabor Shockless Jarring machine is manufactured by the Tabor Mfg. Co., Philadelphia.

CONTINUOUS MELTING.*

By Geo. K. Hooper, M.E., New York

I am very glad to be able to discuss the subject of Continuous Melting, as it is one in which I am deeply interested and one with which in my experience of the last ten years in designing and building foundries, I have been intimately connected. My first piece of work, in fact, as an engineer was the development of a very complete continuous foundry system, and I have since designed several others and been connect-

* A discussion on Mr. Sleeth's paper presented at Cincinnati Foundrymen's Convention and reproduced in the January issue of Canadian Machinery.

ed with other foundries containing systems more or less continuous and am at present building for a well known interest a very large malleable foundry, embodying quite a complete system of mechanical handling, it being impossible in this case, of course, to carry on continuous pouring although the melting proper goes on practically all day.

Out of this experience I am enabled to enlarge somewhat upon the answers to questions asked Mr. Sleeth, for instance, that of, "on how small a tonnage can continuous melting be made to pay." He answered that this depends upon the work in any particular foundry upon which I would enlarge by saying that the tonnage has less influence on the economies to be gained by operating continuously than the number of molds to be handled, as it is at once apparent that a few molds may contain a large tonnage to which continuous methods would be entirely unsuited, while a less tonnage frequently is distributed in a very large number of flasks, the handling of which, with the sand, castings, cores, etc., would undoubtedly yield large economies if carried on mechanically and continuously. The mold, therefore, is the unit which must be used when considering whether the continuous method can be applied to any particular production, but it is not necessary to feel that if many sizes of molds are used, the system is inapplicable since, as the sand is handled mechanically, it may be a considerable saving to standardize flasks to a few sizes and adapt the patterns to these standardized flasks, thus enabling a larger range of work to be handled with a minimum of difference in equipment in flasks, machines, etc.

Hot Sand.

Again Mr. Sleeth was asked if the hot sand has any effect in causing loss of castings, his answer very truly being that generally it has no such effect if the pattern plate be suitably warmed. He spoke of a twenty-minute period as the time in which his sand is in circuit. I am able to enlarge upon this by saying that by means of large cooling and mixing riddles it is possible to considerably shorten this time and consequently the amount of sand handled and I am familiar with systems where the sand is actually in use again in a much shorter time than this, the first system with which I had to do, having the sand in transit less than three minutes from the time when it was dumped out hot, riddled, cooled, tempered, mixed and again deposited in the hoppers over the machines for reuse, going again into the

mold undoubtedly within another three minutes.

Since the proof of the pudding lies in the eating, I am able to say that the foundry loss in this system was much less than when the molds were made on the floor, and this is, I find, the general experience of all who have these continuous systems, viz.: that they operate with less foundry loss than the same work when made on the floor even though a lower rate is paid for labor in operating such system than is customarily paid in floor work.

It is proper at this point to speak of methods of handling molding sand by means of conveyors, and I will say of this that in my experience, belts are the most suitable for this purpose. Canvas belts can be efficiently used where the sand is dry as in shaking out or dumping conveyors, but with tempered sand a rubber belt is preferable, as the sand will more freely discharge from it, and the moisture of the sand will have less effect on the belt's surface. Flat belts are superior to troughed belts for this service, and wide belts moving slowly than narrow fast-running belts.

A drag or scraper conveyor may be used in distributing sand to hoppers over molding machines, and is in fact, the best device for this service, and it also should be large and slow moving, both to avoid wear and to preserve the condition of the sand since the tempered molding sand has a tendency to "ball," and once in that condition must be crushed or dried to again render it suitable for use. The drag conveyor is preferably made with a wooden trough and wood conveyor flights.

Netting on riddles and sieves is preferably made of phosphor bronze wire. Tap bolts and nuts on apparatus requiring renewals should also be of bronze.

One and Two Storey Foundry.

A type of "continuous foundry" has attracted considerable attention the past few years in which the moulding and pouring is done on one floor, the shaken out sand falling through gratings into a basement, where it is suitably prepared and sent again by elevators to the floor above for reuse. I have failed to discover any advantage in a foundry constructed in this way and it possesses, in fact the very serious disadvantages of high cost of installation and operation, since a two-storey building costs at least three times as much as a one-storey building — probably the difference is greater than this, where a floor is filled with gratings and supports for machinery, a large expense is involved in duplication of equipment for screening and

retempering sand, and more labor than is necessary is employed in this latter work.

It is entirely possible to handle all of the sand required by productions up to 100 tons of castings per day and over with two men although as much as 100 tons of sand per hour may be passing through the systems.

The users of a very successful system handling a large tonnage have informed me that they use no men at all on their sand-handling system, but it is difficult for me to believe that it is not given some attention during the day. I believe though that two inexpensive men can handle the largest sand conveying system.

Such two-storey foundries are therefore in my opinion and experience much more expensive to build and operate than modern practice makes necessary.

Mold Conveyor.

Mr. Sleeth was further asked if any damage is noted to molds from the movement of the mold conveyor to which he suitably responded that none is noticed. This would, in fact, be predicated by the fact that the foundry loss in these systems is generally less than in floor work, but I can go a step farther than this and say that molds may be subjected to what would be considered very rough treatment and yet suffer no damage, as I have repeatedly loosened up all connections on a mold conveyor and shaken the car conveying a mold with all my strength while it was being poured, banging the carriage against its supports hard enough to slop the iron out of the sprue and found no apparent defect by sufficient commercial test in the casting.

The casting made in these molds was a hollow casting of varying lengths and thin section poured from one end, the core held by a pivot at one end only, resting upon wire chaplets bearing against tin "spots" in the core for the remainder of its length.

I am familiar with mold conveyors in which the carriage is suspended from an overhead track and allowed to swing free except at the point where the pouring is done and no trouble is experienced by damage to the molds. A gain is in fact made by building a mold conveyor in this way as less power is required for driving it, less wear is entailed, and the supporting frame work is cheapened.

I have learned of a continuous foundry in which the molds when made are carried to the cupola upon trucks provided with springs, poured and then carried on to a cooling and dumping point and I am advised that the loss in this

foundry is less than it was when the same molds were poured upon the floor by bringing the iron to them.

Cupola Operation.

The operation of the cupola was also touched upon. My experience goes to show that this is perhaps the most easily managed function of the whole system since, if the blower—and I think the positive blast blower is best for the purpose—be driven by a direct connected engine with its valve easily accessible from the pouring platform, great variations in melting speed may be obtained with little detriment to the quality of the iron, and by thus handling the blower and having means of communicating at the same time with the charging floor, the cupola may be easily held for considerable periods, such as for changing patterns, etc., etc., and operation started immediately when desired. I have spoken of stopping for changing patterns on purpose, as there is little need for extended stops on any other account, as a suitably designed system will operate on less than 2 per cent. loss of running time from accidents.

The cupola is preferably run with an eye to the production of castings rather than the saving of coke, but this, of course, settles itself and a ratio develops itself which may easily be as high as the best cupola practice affords. Mr. Sleeth has told you, in fact, that his is between 10 and 11 to one. It is much better, though to produce castings than try to save coke.

I am a little surprised to find among foundrymen, otherwise so well informed, an impression that this continuous method is in an experimental stage. Nothing could be farther from the fact, as the method is so aged that the "Mother" patents upon it have expired, and the former owner of them, who is here, has just told me that his original system has been running for eighteen years, and is still in use. I had the privilege of building quite a complete plant some six years ago for his company, in which three systems were installed, one entirely continuous and two intermittent, that is, in one the molds are carried, and in the others, only the sand is handled by conveyors, the molds being poured on the floor from iron brought on overhead tracks, and these systems have been in continuous operation. His company is now building a foundry containing four continuous systems. My own experience with this method began ten years ago with a system which was put into successful operation.

Mr. Sleeth's has been running for undoubtedly fifteen years, perhaps longer.

I am familiar with it for about twelve years, and there are a sufficient number of others in successful and every day operation to put the scheme entirely out of the class of experiment.

There have, of course, been some attempts which have been notable failures, several systems having been devised and installed by builders of conveying machinery, who have attempted to handle molding sand as they would other and very different materials, and who have not had a sufficiently adequate comprehension of the comparative relations of the foundry operations involved, and on the other hand, many capable foundry men have designed systems which they have tried to make too automatic. I can recall one generally on the lines of Mr. Custer's design, but which failed through not having his permanent mold.

He has put the continuous method very far forward and is entitled to great credit for his success.

Elasticity is very essential in every function in the continuous method with the sand mold and plenty of "elbow room" where the different operations are brought together.

Finally then it appears to be demonstrated by the considerable number of successful systems in use that by means of mechanical handling systems in the foundry the efficiency of the workman is increased from 10 to 50 per cent. (this increase having been duly charged, with what additional non-productive labor is necessary), the average wage can often be reduced somewhat, the foundry loss is decreased, the floor space reduced sometimes by as much as one-half, this also taking account of necessary additional power plant, etc., and by mechanical handling only, can the full capacity of molding machinery be realized.

The increase in capacity available from molding machinery is considerable, even though sand handling machinery only be employed, as in some classes of work, sand handling machinery only is possible, malleable work for instance, in which the melting is done in the air furnace, while investment charges are not seriously increased when the saving in equipment due to increased efficiency is considered.

DIFFERENTIATION OF STEELS.

Bermann (*Zeitschrift des Vereins Deutscher Ingenieure*) finds that the sparks emitted by the different kinds of steel when ground on an emery wheel afford a means of differentiation. For instance, the sparks from carbon steel take the shape of spiny tufts, the number of spines increasing with the car-

bon content. In manganese steel the individual rays of the tuft exhibit terminal branchings, whilst in tungsten steel the individual rays are difficult to detect, except that the ends show decided nodes. The sparks themselves consist of particles of metal abraded by the emery granules, which have become heated to whiteness or even above the melting-point partly by the oxidation of the iron, carbon, and silicon, but chiefly by recalcinescence through the conversion of the contained carbon into different modifications.

ORDERS AND EXPECTATIONS.

The machine-shop foreman rushed into the foundry just as the iron began to come down. His words were few for time was scant.

"I want a casting in an awful hurry and I want it bad. I've had a breakdown. Put someone at it who knows how to get a move on."

He got what he asked for. The casting was bad enough to please anybody who wanted that kind. For all that, he was not satisfied. Some people don't always say what they mean.

NON-SHRINKING ALLOY.

A non-shrinking alloy, according to The Metal Industry, is composed of the following: Tin, 50 lb.; zinc, 50 lb. This gives a tough, hard metal that runs well if a good grade of zinc is used. The addition of 2 pounds of bismuth will render it even more fluid and enable it to be poured at a lower temperature. By using heavy sprues and pouring cold the shrinkage, which is slight, may be to a very large extent overcome.

LARGEST LOCOMOTIVE IN CANADA

The largest locomotive ever manufactured in Canada has gone west over the C. P. R. to work on the company's grades in British Columbia. This engine was constructed in the Angus shops at Montreal, and was especially designed as a type for a series of large engines particularly adapted for heavy grades. This engine can pull an ordinary freight train of 1,140 tons over a 1 3-5 per cent. grade with ease, while any engine now in use would have to take a similar train over this grade in two sections or else use two engines.

It has been estimated that a square foot of uncovered pipe, filled with steam at 100 pounds pressure, will radiate and dissipate in a year the heat obtained by the economic combustion of 398 pounds of coal. Ten square feet of bare pipe corresponds approximately to two tons of coal per annum.

Growth of the Canadian Iron and Steel Industry

Eight Years' Progress, Showing the Output of Iron and Steel, Enlargement of Plants, the Increased Market, and the Future Outlook.

By T. J. DRUMMOND*

The early part of 1909 was naturally lean, but as the months went by and people began to realize that they were more frightened than hurt, confidence grew, and buyers began to come into the market. Construction projects that had been held back were taken up again and from the second half of the year, confidence has grown day by day, and, notwithstanding the early slackness, I believe that the production of pig iron—the base of all iron and steel work—has reached its high-water mark in Canada at the close of 1909, with an output of about 800,000 tons.

It is best to commence with pig iron. While a total annual production of 800,000 tons of pig iron may seem insignificant, still from a Canadian point of view it is satisfactory as an evidence of growth in the face of the many initial difficulties, and as a promise of the future.

Prior to 1900 Canada's necessities in pig iron and steel had been to a very large extent cared for by import from the United States, Great Britain, Germany and Belgium. Honest attempts had been made by private efforts and Government encouragement to establish the industry, starting (as it should, to be successful) from the ore up, and while in the base industry very little progress was apparent, it was the pioneer work of the late years of the 19th century that has made possible the success of the first decade of the 20th.

Canadian Pig Iron Record.

In no single year up to and including 1900 had Canadian blast furnaces produced as much as 100,000 tons of pig iron, and the steel production had been less. In 1895 only 37,825 tons of pig iron were produced in Canada, and the year 1900 showed only 86,090 tons, an advance, it is true, but a very slow one. With the growth of confidence in Government encouragement, advancement became more apparent, old works were enlarged, and new plants installed, notably at Sydney, Sault Ste. Marie, Hamilton and Midland. 1901 showed a production of 244,976 tons of pig iron, and 1902, 319,557. Since then the growth has been steady, and we find 1907 showing 651,962 tons, 1908 (an off year), 630,835, and, as already stated,

it is expected that the 800,000-ton mark will be reached when the figures of 1909 are totaled.

Plants Being Enlarged.

With confidence in the future of our country, we of the iron industry are continuing to develop and extend our operations. Important additions are now being made to the blast furnace plants of the Dominion Iron & Steel Co., Sydney, the Lake Superior Corporation, Sault Ste. Marie, and the Canadian Iron Corporation at Midland, which will bring the capacity of the Canadian furnaces up to about 1,250,000 tons of pig iron per annum before the close of 1910, and in 1911, with these new plants in operation, we should have a production of at least that quantity.

That there is warrant for these additions is evidenced by the fact that, notwithstanding the increase in Canada's production, pig iron continued to be purchased abroad in large quantities, 1908 showing 207,053 tons as having been imported.

While pig iron is naturally the barometer by which a country's position in the iron and steel industry is judged, still, it is interesting to note what is happening in some of the more finished products of iron and steel.

The Steel Production.

Previous to 1900 Canada produced less than 100,000 tons of steel per annum, and the first considerable advance came with the opening up of the Sault Ste. Marie rail mill in 1904, quickly followed by that of the Dominion Iron & Steel Company's mill at Sydney. Prior to 1904 steel rails for steam railway purposes were on the free list. The Government had, however, in 1903 taken power to direct, by order in Council, that a duty should be imposed on rails when the Governor-in-Council was satisfied that rails of the best quality were being made in Canada in sufficient quantity to meet the ordinary requirements of the market. In 1904 the Algoma Steel Company demonstrated at the Soo that these requirements were being met, the duty went into force, and Canada made its first great stride in the increase of steel production. In 1902 we had imported 179,591 tons of rails, and in 1903, 203,751 tons. Since 1904, however, the two Canadian mills have

cared for all rail requirements, which at present mean about 350,000 tons per annum.

Ingots, blooms and billets still are imported in moderate quantities, but the Canadian steel industry is gradually overhauling the demand. In the face of the increasing market, in wire rods the imports have decreased from \$792,078 in 1905 to \$295,122 in 1908, and when the new rod mill is installed at the Soo Canada will be able to care for its full requirements in this important article. On the whole the growth of steel production in Canada is as marked as in pig iron. With less than 100,000 tons before 1900 we produced 706,782 tons in 1907, and in the poor year of 1908, 588,763, and will probably reach the 800,000-ton mark before the close of 1909.

In comparing the total production of steel with that of pig iron it may be well to point out that in the manufacture of steel varying quantities of steel and iron scrap are used in conjunction with pig iron, so that, while the production of pig iron and steel is to-day practically equal in tonnage, a considerable portion of pig iron produced goes into the foundry trade, which has made almost as great progress as the steel industry.

Growth of the Market.

To capture the growing trade new and larger mills must be erected to care for the heavy structural and other sections, plates, etc. The extension of the tariff so as to give equal protection on the heavier sections to that now afforded the lighter ones will help towards an increase in home steel production, and it seems safe to assume that this will be done either by extending the clauses now, or by the Government following the same procedure as in the case of steel rails, i.e., by providing for the extension of clauses when the heavier sections are being made in Canada. With this in view the Lake Superior Corporation is erecting at Sault Ste. Marie two mills, which should be in operation by 1910, and which, under favorable conditions, should add materially to Canada's output of steel.

Future of the Industry.

In the future of the industry I have every confidence. With increasing confidence, the demand for our products will increase. Natural conditions are daily improving through the discovery and opening up of iron and steel deposits, and we are also being greatly aided by the influx of new capital, especially from Great Britain, and the growth of the knowledge not only in Canada, but abroad, that the iron and steel industry of Canada is making good.

*President of the Lake Superior Corporation.

INDUSTRIAL ^A_N^D CONSTRUCTION NEWS

Establishment or Enlargement of Factories, Mills, Power Plants, Etc.; Construction of Railways, Bridges, Etc.; Municipal Undertakings; Mining News.

Foundry and Machine Shop.

The Toronto Wire Nail & Tack Co. will erect a \$4,500 factory.

The National Wire Co. has purchased a factory site at Toronto.

Jack & Hay, machinists, Dauphin, Man., are succeeded by J. H. Johnston.

The Reddington Rock Drill Co., St. Catharines, has obtained a charter.

The Munro Steel & Iron Works, at Winnipeg, were damaged by fire recently.

The Kingston Shipbuilding Co. is planning to erect a repair shop, costing \$150,000.

The Dominion Corrugated Steel Pipe Co., St. Johns, Que., has been incorporated.

Chas. A. Colville, machinist, Hamilton, has sold his business to Rothwell & Hall.

Quality Beds Ltd., Welland, will enlarge this year, greatly increasing their capacity.

The R. Watt Machine Works, recently burned at Ridgeway, will rebuild at Chatham, Ont.

The Verity Plow Co., Brantford, will erect an addition of 100 feet to the foundry department.

A big company is being formed at Sussex, N.B., to manufacture the Acme steel ladder on a large scale.

The Canadian Safe Co., recently incorporated, for the manufacture of office safes, is looking to locate at Windsor, Ont.

The Dain Manufacturing Co., of Welland, are perfecting plans for the addition of an automobile factory to their plant.

The Michigan Central Railway has in contemplation the early erection of new shops and roundhouse at St. Thomas.

The six-storey factory of the Munro Steel & Wire Works, at Winnipeg, was badly gutted by fire on January 12, loss \$60,000.

Port Dover has voted unanimously to give assistance to the Widespread Implement Co., the vote being 198 to 0 in its favor.

Plans are being prepared for an annex to the pipe shop of the Canadian Iron Corporation at Fort William, to cost approximately \$50,000.

The Disston Saw Works at Toronto have moved their factory and office from Adelaide Street to their new premises on Fraser Avenue.

Fire which broke out in the cupola of a furnace of the Canadian Iron & Foundry Co., Montreal, did damage to the extent of some \$40,000 early in January.

The Canada Iron Corporation have definitely decided to rebuild their iron pipe foundry, which was completely destroyed by fire about two months ago at Three Rivers.

Samuel Trees & Sons are rapidly pushing along the repairs to the Fraser Foundry at Whitby, preparatory to reopening the industry.

The Armbrust Canadian Brake Shoe Co. have purchased some land at Toronto. They purpose building a factory, and operations will start at once.

The Cossitt Co., makers of harvesting machinery at Brockville, sustained some loss through fire at their premises about the middle of January.

The new C.N.R. roundhouse at Ottawa, will be finished shortly when a complete mechanical equipment capable of handling twelve engines, will be installed.

Chas. Pickard, Chas. W. Fawcett, (both stove manufacturers of Sackville, N.B.) and others have formed an electric machinery and development company at Sackville.

Welland has granted a fixed rate of taxation of \$10,000 to the Electro Steel Co. This plant is now under construction and will be as an experimental plant before erecting a larger one.

H. H. Smalley, Hartland, N.B., has taken over the farm machinery business of Hagerman & Baird, together with a lease of their large hall, and will conduct a general machinery agency.

It is understood that the Dominion Iron and Steel Co. will add a plate mill to their establishment at Sydney, the product to enter into the construction of war vessels to be built at Montreal and Halifax.

A company capitalized at \$150,000 has been formed in Vancouver to manufacture the automatic car fender, crude oil burner, automatic dump car release and other inventions of Henry Clay Jordan, of Vancouver.

A building permit has been granted to the Canada General Electric Co. for the erection of a large brick warehouse at Vancouver. The structure will cost over \$30,000. Murray & McMillan are the contractors.

The Lee Mfg. Co., Pembroke, manufacturers of incubators, refrigerators, kitchen cabinets, etc., have purchased a foundry and will take up the manufacture of stoves and ranges. Patterns are now being prepared for next fall's trade.

According to the terms of a contract just closed Windsor will add a third automobile factory to its list of industries with the next two months. All the companies are branches of Detroit concerns.

The Grand Trunk Pacific Dock Co., with a capital stock of \$150,000, has been organized in British Columbia to undertake the construction of the new docks at Seattle, Victoria, and additional docks at Prince Rupert.

Partridge & Son, of the Crescent Wire Works, Kingston, are to establish a plating department doing all kinds of silver, nickel and gold plating. The new plant is being installed, and will be in operation within a couple of weeks.

The B.C. Marine Railway Co. are making arrangements to greatly enlarge their shipbuilding plant at Victoria. Capital has been subscribed by English financiers and the enlargement of the works is considered practically assured.

A charter has been granted the International Dredge & Dock Co., Toronto, capitalized at \$50,000, to manufacture and deal in machinery and supplies. W. A. Lydon, W. Cahill, and H. C. Wild, all of Chicago, are provisional directors.

Swan & Hunter, the great English shipbuilders are said to have purchased a site at Dartmouth, N.S., and that they will spend a million dollars on a plant there. In one year's time they expect to be able to construct first-class cruisers as well as merchant ships.

The Canadian Car & Foundry Co., Montreal, elected the following directors recently: N. Curry, president, James Redmond, chairman of the executive; H. S. Holt, Geo. E. Drummond, I. H. Benn, T. J. Drummond, executive; W. W. Butler, first vice-president; N. S. Reder, second vice-president, and W. M. Aitken, executive.

The boiler and machinery have been installed by the Schaake Machine Works of New Westminster, in the new steamer which is to run on

Lake Harrison for the Brooks-Scanlon Lumber Co. The machinery for the Paystreak, made by the same company, is now ready and it will be installed as soon as the boat is brought to the works.

Citizens of Sydney voted almost unanimously in favor of the establishment of rolling mills there. Construction of the buildings will, it is expected, start early in April, and the amount to be expended by the company will not be less than \$550,000, while the amount to be expended during the construction in wages will be in the vicinity of \$150,000. The plant will employ about 500 men.

The municipality of North Vancouver has agreed to guarantee the interest on \$200,000 of debentures of the Imperial Power Shipbuilding and Dock Corporation, for a period of ten years, and will exempt the company from taxation for a like period. The company agree to spend the sum of \$300,000 on construction and plant alone. The manufacture of railroad cars will be undertaken.

Justice Clute made an order at Toronto a fortnight ago staying the winding-up proceedings ordered on September 8 last in the matter of the Atikokan Iron Co., and discharging the liquidation. The stay was asked by Mackenzie & Mann, who are large shareholders, and say they have secured sufficient to pay off all the debts.

George T. Rosselle, of Cincinnati, acting on behalf of Geo. H. Paine, a Cincinnati capitalist, has completed the purchase of the stock and machinery for the manufacturing of the Sunlight gasoline light from the Sylvester Mfg. Co., Lindsay. A company for the manufacturing of gasoline lighting and heating devices exclusively will be organized and an industry started in Canada.

The machinery for the Modern Malleable Range Co.'s stove and range factory, which will shortly start operations at Chatham, Ont., is being shipped in from Leamington and will be installed in the premises formerly occupied by the Chatham Motor Car Co. These buildings will be used till the completion of the proposed large factory, the contracts for which are now in the hands of John Piggott & Sons.

George McCrae, superintendent of the Gould, Shapley & Muir factory, Brantford, was in Dunnville recently, endeavoring to form a stock company for the manufacture of gas, gasoline engines and mining machinery there. The town is being asked for a loan of \$30,000, and the citizens of Dunnville are being asked to subscribe \$25,000. The company will employ 50 hands to start, and eventually 100 hands.

The Blair Engineering Co., which is opening a branch at Montreal and which has a capital of \$100,000, is handling an invention which is being installed in open-hearth furnaces in several steel companies in the States, and is being inspected by Canadian concerns. The directors are William Johnson, Alfred La Rocque, Michel Benot, Thomas G. Blair, jr., J. S. Andrews and Roswell F. Munday, of Chicago. The American company has shown large profits.

Charles McDonald, manager of the St. John Iron Works; Stanley E. Elkin, of the Maritime Nail Works, and James Pender, of James Pender & Co., wire nail manufacturers, visited Ottawa recently to meet the railway commission. They protested against an increase in the C.P.R. freight rates on iron, steel and wire nail, shipped from St. John to points in Central Quebec.

CANADIAN MACHINERY

It was claimed that the increase was unwarranted. The commission after hearing the delegation announced their decision to have the old rate restored.

The annual meeting of the shareholders of the Good, Shapley & Muir Co., manufacturers of gas engines, windmills, etc., was held recently, when the officers elected were: E. L. Good, president; W. H. Shapley, vice-president; John Muir, manager; W. H. Whitaker, secretary, and Henry Yeigh, treasurer. In order that they may cope with the demand for the new gas traction engines, plans have been drawn up, and tenders asked for up-to-date engine and machine shops, 180 x 50, 180 x 50, 32 x 50 respectively, which will be modern in every respect.

The Vulcan Iron Works, New Westminster, have arranged with the Willamette Iron Works Co., of Portland, Ore., whereby the former company will make all the boilers for locomotives built by the American firm for use in Canada. The Willamette Co. has found it impossible to manufacture at its plant in Portland boilers to meet the requirements of the B.C. Boiler Inspection Act and make any profit after paying duty into British Columbia. This means a big business, as all the large lumbering and logging concerns use locomotives and many that are now ordered will have their boilers built at New Westminster.

The by-law authorizing an agreement between Fort William and the Superior Rolling Mills Co. was carried by the ratepayers at the municipal elections early in January. This means the establishment at Fort William of what is believed will develop into one of the largest plants in Canada. According to the agreement, the company is to erect a thoroughly up-to-date wire and nail factory, employing at least one hundred men for 250 days in the year at ten hours each day. The names of those to the agreement are: F. W. Thompson, managing director of the Ogilvie Co.; H. S. Holt, president of the Montreal Light, Heat & Power Co., Montreal; T. Drummond, vice-president of the Dominion Steel Corporation; W. T. Phippen, general counsel of the Canadian Northern Railway; W. A. Black, Winnipeg, western manager of the Ogilvies.

Municipal Enterprises.

Montreal council has been asked to vote \$1,000,000 for a filtration plant.

Nanaimo ratepayers will vote on a by-law to raise \$100,000 for a sewerage system.

The Works Committee of the Regina city council recommend the spending of \$363,000 on a trunk sewer.

At a recent meeting of the Hull city council the tender of the Willam-Hamilton Co., Peterboro, was accepted for the pumps and water-wheel, for which tenders were sent in at the last meeting of the council. The price to be paid for the pump is \$14,850 and \$2,065 for the water-wheel.

Contracts for the annual supplies required by lets at 30 cents each; James Robertson Co., granted to the Dominion Sewer Pipe Co., for sewer pipe; N. L. Piper Ry. Supply Co., metal house numbers; McClary Mfg. Co., street tablets at 38 cents each; James Robertson Co., lead pipe, at \$5.29 per hundred pounds; Canada Metal Co., brass and bronze castings; Canada Foundry Co., cast iron pipe (12-inch), at \$16.75 per length; hydrants and stop valves, Gutta Percha Rubber Mfg. Co., and Dunlop Tire & Rubber Goods Co., rubber valves; Keith & Fitzsimons Co., Somerville, Ltd., and Dean Bros., brass work for house services; Reid & Brown, iron valve and stop cock boxes, and special castings at \$2 per hundred; Portland cement, National Portland Cement Co., \$1.57 per 350 lbs. net.

Structural Steel.

A bridge will be built over the Lottridge inlet, at Hamilton, at an estimated cost of \$2,000.

The Ontario Iron & Steel Co., of Welland, has

given a contract to the Hamilton Bridge Works Co., to build an extension to its plant, 170 by 50 feet.

There will be about 25 bridges erected along the proposed 200-mile extension of the Algoma Central Ry. One of these bridges will cost in the neighborhood of \$25,000.

D. E. Easson, of Peterborough, one of the staff of civil engineers on the Trent Canal, took final measurements for the steel superstructure of the contemplated Wellington Street bridge at Lindsay.

At a meeting of the Vancouver bridge committee it was decided to tender Waddell & Harrington, of Kansas City, \$28,000, to cover all engineering expenses in connection with the Cambie Street bridge. This will cover inspection of plans, field work, direction of work, etc.

The contract for clearing the debris of the Quebec Bridge from the south shore has been awarded to Captain Charles Koenig and Co. The contract specifies that the clearing of the debris must be finished by May 1 next, when R. and J. G. Davis will begin the reconstruction of the piers.

F. W. Holt, C.E., in his report on the harbor bridge project at St. John, figures the cost of a satisfactory bridge at \$749,577. Mr. Holt says, as designed, the bridge is intended to have a 32 foot highway and an 8 foot sidewalk 25 feet above railway track and two street railway tracks on the same level. The three tracks are side by side inside of the trusses to simplify the counter-balancing of draw.

Two engineers of the Cleveland Bridge and Engineering Co., of Darlington, Eng., J. H. Walker and J. R. Dixon, are in Quebec looking over the site of the big bridge, with the intention of putting in a tender for the work on behalf of the company they represent. The Cleveland Bridge Co. is one of the foremost concerns in England and has carried out a large number of big engineering works in England, India, Africa and other parts of the world.

The substructure of the C.P.R. bridge at Edmonton will cost \$500,000. Plans have been prepared for the bridge which will connect Strathcona with Edmonton, and a deputation has gone to Ottawa to solicit the aid of the Dominion Government in bearing the expense. The structure will cost about a million and a half, of which sum the C.P.R. will pay nearly a million but the balance has to be raised by the city of Edmonton and the Governments. The bridge will be 2,687 feet long and 166 feet high.

The Dominion Bridge Co. has commenced active work on the erecting of the four new steel spans which will complete the Fredericton-St. Marys Highway Bridge. The first shipments of steel have arrived from Montreal and the travelers to be used in the work of erection have also arrived. The largest travelers are over 50 feet high, being somewhat higher than those used on the bridge heretofore. Superintendent McMahon has a crew of men coming here from a job near Bathurst and will have about fifty men employed on the work. The contract calls for the four spans to be ready for traffic by April 1st and it is the biggest contract of the entire superstructure.

Electrical Notes.

The office of the Dufferin Light and Power Co., at Orangeville, was burned on Jan. 9.

New tenders for electrical equipment for the London power station will be called for.

The Lethbridge city power plant was totally destroyed by fire on Jan. 2, rendering the city without light or water.

In Paris, the by-law for taking the first steps with a view to securing Hydro-Electric power, carried by a large majority!

The Northwest Battery Co., Winnipeg, will install the lighting plant at Moose Jaw. G. K. Watson will superintend the installation.

The International Contract Co. is now engaged in installing a motor at the new Lulu Island bridge at New Westminster for the purpose of operating the swing span by electric power.

The new centre for Hydro-Electric power that will be created as a result of the favorable votes in Brampton and elsewhere, may mean a considerable reduction in the price of power to Toronto itself.

It is almost certain that the Calgary civic power and light plant will be moved during the year. The increasing business necessitates the extension of the plant and a change of site must be made.

The addition the city of Kamloops is making to its lighting plant will give that city the largest and most complete lighting system in the interior of British Columbia with one exception, that of Nelson, B.C.

The Canadian Niagara Power Co. intends erecting a power plant at Bridgeburg; the value of the plant to be \$60,000; well equipped with transformers, switches and distributing circuits, to be erected in the early spring.

J. N. Winslow, who was appointed by the New Brunswick Government to look into the value of the power of Grand Falls, has placed the same at \$300,000. It is stated that an American syndicate is seeking to acquire the power.

The work of preparing the ground in the rear of the Westminster Avenue car barns, at Vancouver, for the erection of a steam auxiliary plant for the B.C. Electric Railway Company, is being hurried forward as rapidly as possible.

City Engineer Ker, of Ottawa, at the recent meeting of the waterworks committee made the proposition that the city should generate its own electricity for the booster it is proposed to install to raise the water pressure for fire purposes.

Two carloads of machinery for the new unit at the city's power plant at Upper Bonnington Falls have arrived at Nelson. Another car was reported at Cranbrook. A. C. Read and Mr. Johnson, of Montreal, machinery experts, are there to inspect the installation.

C. H. Colgrove, M.E., hydraulic expert, has decided on a point on the Saskatchewan river about 110 miles from Edmonton as the source of power for that city. Minimum power is estimated at 20,000 horse power. The proposition is now being investigated by a group of hydraulic engineers.

Another 10,000 horsepower unit will be installed at the Canadian plant of the Canadian Niagara Power Co., at St. Catharines, making the sixth of that type. The generator has been ordered from the Canadian Westinghouse Co., at Hamilton, and will be delivered so that it may be assembled in the spring. The turbine will be delivered by the Bethlehem Steel Co.

A special committee of the Sherbrooke City Council has made a recommendation that the city buy the drop-off power on the Magog river and also the dam at the outlet of Little Lake Magog from the British American Land Co. They set the price at \$8,000. This property is required or will be required shortly by the city for more power for the electric light plant.

The B.C. executive council has granted the request of Prince Rupert citizens for an advance from the provincial treasury of a sum of \$50,000 for the requirement of the pole line of the Prince Rupert Power & Light Co., and for the construction and installation of proper buildings and plant for the supply of electric light and power to Prince Rupert users of these modern essentials.

An interesting feature in connection with the operation of the lumber mills of the Fraser River Lumber Co. in New Westminster is that they have found that too much power is lost by friction, and it is the intention to install separate motors to be operated by electricity, where-

ever possible in connection with shingle machines, etc. Many of these motors have already arrived and will be installed immediately.

There is some talk in Levis, Que., of the possibility of the municipality purchasing the Dorchester Electric Co., which is capable of developing 1,000 horse-power. The Dorchester Electric Co. recently obtained the right to enter Levis, and in some circles the idea of purchasing has been developed with a view to opposing the Canadian Electric Co., which has just passed over to the Quebec Light and Power merger.

As a result of the remodelling and rebuilding of power house No. 2, better known as the "Old Standard," on Amelia Island, at the Chaudiere, the Ottawa Electric Co. will be able to double the amount of power hitherto generated there. New machinery throughout is being installed and the water level in the flumes is being raised from 22 feet to 33 feet. Formerly only 2,000 horse power was being developed at this point.

The total earnings of the Nelson Light and power department, in 1909, were \$52,237.20, and the expenditures \$16,651.97, leaving a balance of \$35,585.23, from which have to be deducted interest on debentures and sinking fund. During the year 100 new connections were made, and the city council is now supplying 80 per cent. of the business houses, 95 per cent. of the residences, and practically all the manufacturing establishments in Nelson.

Citizens of Melville, Sask., voted on an electric light by-law on Jan. 4, the result of the poll being 60 for the by-law and 8 against. This by-law gives Cushing & Weir a franchise, but not an exclusive one, to erect an electric light and power plant in Melville for a period of ten years, when it may be purchased by the town. Work will be commenced at as early a date as possible, and the plant has to be in operation by July 1. Its cost will be in the neighborhood of \$30,000.

Three gentlemen representing the Shuswap Falls Light & Power Co. are negotiating with the Armstrong, B.C., council for the purchase of the town's electric light plant. The company represent their plant as being capable of supplying light for the whole valley from Penticton to Sicamous. The company will sell light at 10 cents per k.w., whereas the people are now paying 16 cents. Another proposition by the company is to connect Enderby, Armstrong and Vernon with Grande Prairie and Salmon River by means of a tramline.

The appointment of J. E. Aldred, president of the Shawinigan Water & Power Co., as director of the Montreal Light, Heat and Power Co., follows on the purchase of 3,000 shares of Power stock, a short time ago, by Shawinigan. The election of J. E. Aldred recalls rumors of a merger between Shawinigan and Power, but no significance is placed in the choice. There is no doubt, however, that Mr. Aldred's appointment will lead to closer relations between the two concerns, with possible ultimate merging of interests.

The application of the Burrard Power Co. for the right to erect a dam at the lower end of Lillooet Lake, B.C., in the railway belt, for the purpose of raising the water in the lake and by diverting the water to a power house to be erected about four miles down the Lillooet River from the lower end of the lake for the purpose of generating electric power, this to involve the right to use 25,000 miner's inches of water in the lakes, has been approved by the executive council at Ottawa. The minimum amount of expenditure to be made in connection with the works annually during the five-year agreement is \$25,000, and the water power to be developed 3,000 horsepower.

For inside wiring at the Montreal electric power house the order went to O'Leary & Co., who secured the contract at \$205, the same firm were also awarded the contract for electric piping for generation purposes and for exciter leads

at \$145. For the supply of two circulating pumps, it was decided to award the contract to Laurie & Lamb, at \$2,300, it being represented that the pumps on offer by that firm were more economical in steam consumption, and that the saving in fuel in one year would almost compensate for the difference in price. Garth & Co. will provide the necessary pipe and fittings at a cost of \$1,029. For a boiler supply the recommendation was for a 250 horse power water tube and the order was awarded to Polson's Iron Works at \$4,615.

The new auxiliary steam plant recently installed at Victoria by the B.C. Electric Co., on the foreshore at Rock Bay opposite the old plant which has been yearly put in operation to meet the demand for power has been given its first practical test. By the installation of the new plant the B.C. Electric Co. has increased its ability to deliver electricity for power, light and heat by 1,000 horse power at an expenditure for building and plant of about \$62,000. The machinery was formerly in use in Vancouver and was installed to give the added power needed consequent of the probable failure of the water power at Goldstream which in past years has overtaxed the old steam plant. For this year the new plant will be used solely as an auxiliary in case of necessity. Until the Jordan river plant is running the new plant will be practically kept constantly in use after this year. The company now has a total horse power of 4,400, of which 3,400 can be secured from Goldstream and the old steam plant and 1000 from the new plant, the largest amount of power in the history of the company here.

Planing Mill News.

J. W. Molson is building a large sawmill at Shawbridge, Que.

D. E. Wallace, of Thamesville, Ont., is making further additions to his sawmill.

A new sawmill is being built a short distance in the rear of the Markdale, Ont., furniture factory.

The Beaver Mfg. Co., Buffalo, makers of wood fibre material, contemplate establishing a branch factory at Ottawa.

It is expected that the Northern Oil Co. will establish works at Victoria, and will also build large wharves and a cooperage and box factory.

The C. C. Manuel & Sons Co., of Richford, Vt. is building a plant in Sutton, Que., for the manufacture of butter dishes, clothes pins and veneers.

Hugh Baird & Sons, formerly of Markdale, Ont., now at Thornbury, Ont., are again entering the lumber business in the spring and expect to put up a new band saw mill of the best fireproof construction.

The Watts Manufacturing Co., of Wattsburg and Proctor, in the Kootenay district of British Columbia, are installing a wire-wound wooden pipe plant in connection with the Proctor mill. The plant is nearly ready for operation.

Statistics of the lumber industry in British Columbia show that the total number of saw mills is 204; capacity, approximate average, 8,080,000 feet a day; shingle mills, 45, with a capacity of 2,250,000,000 yearly; logging camps, 265; donkey engines and logging locomotives, 267; horses employed, 1,500; men employed, 17,000.

Seaman, Kent & Co., hardwood finishers, will erect a plant at Fort William, which will employ 100 men and will ship to the west the first year 500 carloads of finished material and 800 carloads a year afterward, provided the city will exempt them from all but a nominal tax. The proposition will be submitted to a vote of the citizens.

Negotiations for the sale of the Canadian Pacific Lumber Co.'s mill at Port Moody, reputed to be the most scientifically constructed lumber manufacturing plant in British Columbia from the point of view of low cost of operation, are

now proceeding between the owners and Meredith and Irwin, who are largely interested in the Anglo-American Lumber Company, of Vancouver. J. R. Booth, Ottawa; the E. B. Eddy Co., Hull, and the James MacLaren Co., of Buckingham, are taking out enough pulpwood to keep their mills running to the fullest capacity in preparation for what promises to be a good season. Mr. Booth is increasing the capacity of his pulp producing plant by 60 per cent. and expects to use all its output in the manufacturing of paper.

Railway Construction.

The Calgary Street Railway will build an extension of about 12 miles during 1910.

A \$2,000,000 electric railway will be built in the Okanagan valley of British Columbia.

The C.N.R. line will be extended to Athabasca Landing, thirty-six miles from Morinville, Alta., the present terminus.

Surveying between Port Colborne and Fort Erie along the lake shore for that branch of the N. St. C. & T. Ry., is now going on.

Three hundred and fifteen thousand dollars will be expended on the New Westminster branch of the British Columbia Electric railway during 1910.

Tenders are now being called for the construction of the V., V. & E. line between Abbotsford and Hope, B.C., a distance of 78 miles, and between Princeton and Tulameen.

A party of G.T.P. surveyors will locate the line from Yorkton, Sask., to the Pass, at which point the G.T.P. will make connection with the Government road to either Churchill or Nelson.

There is a project on foot at Vernon, B.C., to build a tram line through the Okanagan valley from Enderby to Penticton and Summerland to handle the rapidly developing fruit and produce business of the district.

A spur line running west from the C.V.R. branch of the Dominion Atlantic Railroad, at Kentville, N.S., will be built. The Provincial Government will give a subsidy of \$3,200 per mile and the Federal the same.

It is proposed to build a six-track subway from the eastern end of Montreal to the western, taking in all the railway stations, etc. English capital is behind the move, which will take in the street railway and power companies, and necessitate an investment of a hundred million dollars.

A new electric railway running northward from Toronto to Barrie, with branches to Orillia and Owen Sound via Meaford, is being organized by Toronto capitalists, and application will be made for a charter at the next sitting of the legislature by W. H. Price, acting for the promoters.

A report from the Soo says that in February the Algoma Central Railway Company will call for tenders for an extension of their railroad 200 miles. It was also stated that the sum of \$3,000,000 was being allowed in the estimates for this purpose. In the extension 64 bridges will be constructed.

The charter granted to the Northern Empire Railway Co. and the Manitoba and British Columbia Railway Co. has been transferred to a new company headed by Henry Roy, a millionaire. Capitalization, \$4,500,000. Among the projects is a line through Peace River Crossing into Dawson and another east from McMurray to Fort Churchill on the Hudson Bay.

To meet demands of the various parts of its extensive system, the B.C. Electric Railway will need over 100 freight cars and more than that number of passenger cars. Half a million dollars has been appropriated for this particular, and orders will be placed with manufacturers in the east. Not only that, but the shops at New Westminster of the company will be operated to

capacity, and every effort made to attend to business offering.

Officials of the Canadian Pacific Railway, in Winnipeg, have made an appropriation, providing for the construction of fifty miles of the Kootenay Central Railway this year. It is proposed to start work early in March at or near Wardner station on the Crow's Nest Pass Railway. Tenders will likely be called for early February. The new line will open up some fertile and agricultural fruit-growing districts in the interior, including the famed Windermere Valley. The route extends north through the Kootenay Valley and thence via the Columbia Valley to Golden, a distance of 160 miles.

The weather in the west has been so exceptionally fine that good progress is reported as being made by the builders of the Grand Trunk Pacific. Freberg & Stone, sub-contractors under Foley, Welsh & Stewart, are drilling a tunnel nearly 400 feet long near Omineca on the upper Skeena river. Construction work on the east end of the Grand Trunk Pacific, also owing to the unusually favorable winter, is still going on. Down in New Brunswick the rails have been laid from Cains river westward as far as Nappadogan Lake, where in the heart of the great Miramichi forest a divisional point has to be established.

New Companies.

Caledonia Gypsum Co., Hamilton; capital, \$150,000; to develop and work mineral lands. Incorporators, Henry Lewis, E. Rubenstein and E. J. Hunter.

Acme Vacuum Cleaner Co., Montreal, capital, \$20,000; to manufacture vacuum cleaners. Incorporators, W. T. Cumming, A. J. Brown and F. G. Bush, Montreal.

John Miller & Son, of Winnipeg; capital, \$25,000; to deal in and manufacture hardware, etc. Incorporators, T. W. Neelands, G. N. Broatch and F. W. Louthood.

Montreal Asbestos Co., Montreal; capital, \$500,000; to mine, smelt and work asbestos. Incorporators, H. C. Organ, Q. E. Baxter and L. Normandin, Montreal.

The Franco-Canadian Mfg. Co., Montreal; capital, \$20,000; to manufacture glass bottles and glassware. Incorporators H. Hubert, T. Lafleur, and L. Mercier, Montreal.

Canadian Safe Co., Windsor; capital, \$100,000; to make safes and vault doors. Incorporators, J. E. Blackmore, Detroit; N. A. Bartlett and A. R. Bartlett, Windsor.

Alex. Bremner, Ltd., Montreal; capital, \$200,000; to manufacture bricks, cement, tiles, drain pipes, etc. Incorporators, Alex. Bremner, A. W. Bremner and Geo. Benoit, Montreal.

The News Pulp & Paper Co., Montreal, has been incorporated with a capital of \$1,000,000. The incorporators are: G. C. Foster, J. T. Hackett, T. F. Coonan, all of Montreal.

The National Engineering Co., Montreal; capital, \$20,000; to manufacture electrical and mechanical devices, etc. Incorporators, R. T. Heneker, A. H. Duff and W. S. Johnson, Montreal.

The Torrey Asbestos Machinery Co., Montreal; capital, \$50,000; to make mining, milling and general machinery. Incorporators, C. G. Greenfields, A. C. Calder and R. E. Allan, Montreal.

Swansea Smelting and Refining Co., Toronto; capital, \$100,000; to mine and treat ores and make articles of metals. Incorporators, A. E. Knox, C. F. Ritchie and J. H. Oldham, Toronto.

The Union Iron Works, Toronto; capital, \$200,000; to manufacture all kinds of machinery and implements, hardware, etc. Incorporators, J. T. White, C. W. Widdifield, and J. H. Cavell, Toronto.

Canada Bolt and Nut Co., Toronto; capital, \$2,500,000; to smelt ores, metals and minerals, and manufacture their products. Incorporators, E. G. McMillan, J. E. Riley and G. B. Strathy, Toronto.

Canadian Merchandise, Ltd., Toronto; capital, \$5,000; to deal in novelties, household utensils, hardware and other merchandise. Incorporators, G. M. Kellam, R. Westwood and C. A. Bailey, Toronto.

The Courtright Stove Co., Courtright, Ont., capital \$40,000, to manufacture stoves, furnaces, gas ranges and electric fixtures. Provisional directors, F. C. Watson, M. Sanders and H. W. Unsworth, Sarnia.

Rogers Supply, Ltd., Toronto; capital, \$100,000; to take over the Rogers Supply Co. and make Portland cement and artificial stone. Incorporators, Alf. Rogers, J. W. Rogers and A. E. Stovel, Toronto.

The International Tool Steel Co., Toronto; capital, \$750,000; to mine and treat metals, carry on a foundry and machine shop, and make tools. Incorporators, S. J. Kelly, Jas. Ross, Chas. Lehmann, Toronto.

The B.C. Gazette gives notice of the incorporation of the following companies; Powell River Paper Co., capital, \$1,000,000; New Columbia River Co., capital \$5,000,000; the Crown Shingle Mill Co., capital \$25,000.

Universal Engineering and Mfg. Co., Montreal; capital, \$95,000; to manufacture, import and export electrical and mechanical appliances and machinery. Incorporators, J. J. Campbell, J. D. Lachapelle and J. C. Dudley, Montreal.

Canada Pipe & Steel Co., Toronto; capital \$100,000; to manufacture iron, steel and metals, and make tools, machines and repair and construct structural work. Incorporators, J. L. Ross, A. R. Bickerstaff and A. W. Holmstead, Toronto.

The Lafrance Improved Pipe Joints Co., Montreal; capital, \$50,000; to manufacture and deal in saws, barbed wire, lead pipe, shot, locks, tools, white lead and paints, etc. Incorporators, J. Lafrance, A. Chagnon and L. D. Latour, Montreal.

Cartwright Automatic Press Co., Montreal; capital, \$500,000; to engage as iron foundries, mechanical engineers and to make printing presses and machinery and tools. Incorporators, J. W. Blair, F. J. Laverty and L. A. David, Montreal.

Baillet's Gas and Steel Machine Co., Montreal; capital, \$45,000; to construct and operate steel plants and gas generators and engage in general foundry and machine work. Incorporators, L. J. Beique, A. Baillet, and A. Menager, Montreal.

The Eastern Electric and Development Co., Sackville, N.B.; capital, \$250,000; to establish electric works and manufacture electric machinery, appliances, devices, etc., and to generate electric power for sale. Incorporators, Chas. Pickard, C. W. Fawcett, Sackville, and M. G. Siddall, Pt. Elgin, N.B.

The Blair Engineering Co., of Canada, Montreal; capital, \$100,000; to take over the Blair Engineering Co., New York, and to make the Blair indestructible port and bulk head for open-hearth furnaces, as well as deal in machinery of all kinds. Incorporators, Wm. Johnson, A. La Roque and M. Benoit, Montreal.

Martin Freres & Cie., Montreal, Que., have been incorporated with a capital of \$100,000, to carry on business as manufacturers and dealers in timber, lumber, logs, sashes, blinds, boxes and woodwork generally; to own and operate timber limits, sawmills, sash and door factories and planing mills. Incorporators: T. B. Martin, F. Martin and others, all of Montreal.

POCKET DIARY FOR 1910.

The "Pocket Diary and Year Book for 1910," published by the Mechanical World, Manchester, Eng., contains considerable new matter, including an entirely new section on oil engines with notes on crude oil engines by W. A. Tooke, who has also revised the section on gas engines. Condensed notes on the design of centrifugal pumps have been contributed by B. M. Woodhouse, and a new section on ball bearings has been included. Among other additions are the following: Dimensions of marine boilers; tapers and angles; change wheels for cutting metric pitches; hobs for cutting involute gears; dimensions of ring-oiled bearings; emery wheel speeds, etc.

Canadian Locomotive Works.

The Canadian Locomotive Works recently completed an up-to-date power house and a new boiler shop. Plans have been drawn up for a new erecting and tender shop and a new foundry. These new departments will be equipped with modern machinery greatly increasing the efficiency and capacity of the plant.

International Harvester Co.

The International Harvester Co., Hamilton, have decided to spend \$100,000 on enlarging their plant. A large addition will be made to the woodworking department. This will be followed by another building to be used for a machine and erecting shop.

Bolt and Nut Merger.

As announced in January Canadian Machinery, Lloyd Harris, M.P., Brantford, has been chosen president and T. H. Watson, Toronto, vice-president and general manager of the Canada Bolt & Nut Co., Toronto, the capitalization of which is made up as follows: Bonds, 6 per cent., 20 years, \$1,000,000; preferred, 7 per cent., \$1,250,000; common stock, \$1,250,000; total, \$3,500,000.

The companies included are the Toronto Bolt & Forging Co.; Brantford Screw Co., Gananoque Bolt Co., Belleville Iron & Horseshoe Co. The remaining directors are G. P. Grant, W. T. Sampson and James Bicknell. Shareholders are offered cumulative preferred shares, and in addition 25 per cent. bonus on the common stock.

1910 CALENDAR.

F. Reddaway, 56 St. Francois Xavier, Montreal, manufacturers of Camel Brand oak tanned leather belting distributed a large office calendar printed in two colors. An installation of a belt outside is illustrated on the calendar.

Big Aluminum Wire Order.

The Aluminum Co., of America, has just been given a contract for 1,500,000 pounds of aluminum wire from the Hydro Electric Commission of Ontario. The wire is for the first of a great series of electric installations which will place that province in the front rank as a section for the distribution of cheap power. The wire is for power lines supplied from Niagara Falls, and will cost about \$400,000. It will be one-half inch in diameter and will be about half the weight of copper. The lines will supply Toronto, Windsor, St. Catharines and Welland, Port Dalhousie and many other municipalities with power to be used either for traction purposes, electric lighting or for manufacturing purposes. It is the plan to supply power by this method throughout the entire province of Ontario. The aluminum wire will be made and drawn at the Niagara Falls and Massena, Que., plants of the Aluminum Co.

Canadian Machine Tool and Metal Markets

WINNIPEG.

Indications are that Winnipeg is to make vast industrial strides within the next two years at least. Every plant and machine shop in the city is working at its full capacity this winter and the business in all directions seems to be particularly bright for this season of the year. Although there is only a small demand for new machinery just now, the fact that trade from the manufacturers' standpoint is good, the machine tool trade has an excellent future. Steel working tools as yet have a weak market in this centre and only specialties are in demand. This is more particularly true of the smaller types.

The woodworking tool market has been and continues to be better. The saw-milling industries of the west are becoming more and more important and last fall many mills were equipped, and orders are in for some large planing machines and lathes. Construction machinery which always forms a large part of the trade in Western Canada is, of course, not called for now, but next season the demand for all types of hoisting engines, cranes and building machines will be very heavy.

The Stuart Machinery Co., are preparing to take care of a large amount of the machinery trade during the coming years. They will be in their new premises within the next few weeks.

The Board of Control again took up the question of appointing an inspector for machinery for the city power plant, and decided to appoint the inspector selected by the power engineers provided the cost would not exceed 1½ per cent. of the total cost of the machinery.

TORONTO.

Business continues to improve and some of the machine tool manufacturers will not guarantee deliveries for five months. Among the best selling lines during the past few weeks are heavy railroad machinery, radial drills and shapers. The prices of machine tools remain steady, prices being kept up by the increasing demand.

All the United States machinery centres report the same state of trade. They report a good volume of inquiries and a large percentage of these are turned into orders and the machinery dealers are anticipating a good season.

In power lines Canadian manufacturers are also busy. One manufacturer stated to Canadian Machinery that business during three weeks of January 1910 equalled the business of Jan. and Feb. 1909.

In the boiler trade, business is excellent and all manufacturers of power lines are very busy. In electrical lines the demand for power equipment is keeping the plants at Hamilton, Toronto and Peterboro very busy. Orders in this line are increasing, a number of them being placed in United States, England and Sweden.

MONTREAL.

An improvement is noted in trade although it has not yet amounted to anything very significant. The mid-winter dullness is hard to shake off, and users who buy at all ahead have not yet started to figure out very seriously what they may require for future needs. The tone of the markets is very good. It was expected that tin and lead would be advanced, but the primary markets fell away, and thus local prices remain unaltered. All the way round, however, prices are firm.

The pig iron and steel situation look very promising. It is true that new business continues quiet, but the trade are glad of this as it enables the plants to catch up with back orders. Delivery is better, and the industry is getting into good shape for the great business

that is anticipated later on. The situation in the United States and the Old Country continues unchanged. There has been a stimulation in iron buying in the States, with the finished steel trade quiet. The elections in the Old Country have disturbed the market there, but trade had kept up well, and when the turmoil is over plenty of business should break in.

Prices show a decided stability and a good demand exists. Quotations are as follows: Summerlee ranges from \$23 to \$24; Middleboro No. 3 and Cleveland, \$22; Glengarnock, \$23.50; Jar-row and No. 1 Clarence, \$21.75; and Canadian foundry iron, \$22.

Speaking of the outlook H. J. Fuller, president of Canadian Fairbanks Co., Montreal, says:

"We know, that many plants are projected to be built during 1910. We ourselves, are, at the present time, building a large addition to our factory at Toronto, and a new factory in Montreal for the manufacture of a line not heretofore made in Canada by us. We believe that during the year 1910 we shall see higher prices and a demand which will be difficult to meet, even with all factories working to their utmost capacity. From one end of the country to the other, nothing but the utmost optimism seems to prevail, and unless the spring should be unusually late and cold, and promise doubtful crops, we see no reason why 1910 should not be the greatest and best year that Canada has ever seen."

W. S. Leslie, president of A. C. Leslie & Co., Montreal, says:—"We look upon the prospects for the iron, steel and metal business as very favorable on the whole. Already nearly all the large buyers have shown their confidence by purchasing good quantities for delivery as far into the new year as producers would contract for; prices generally are stiffening and the advance seems to be fully justified by improvement in general trade conditions, and there is very little, if any, appearance of an attempt unnaturally to boom prices. We look for a further improvement as soon as the election in Great Britain is over."

Wm. McMaster, vice-president and general manager of the Montreal Rolling Mills, says:—"I look forward to a larger business in iron and steel products this year in comparison with 1909. The improvement in business in the United States, with the advances in prices, and the better feeling as to values in Great Britain and the Continent, all influence the opinion that 1910 will be a prosperous one for Canada."

CATALOGUES.

FLOATING REAMER HOLDER.—The Colborne Machine Tool Co., Franklin, Pa., have issued bulletin No. 40 which describes floating reamer holders made in two sizes for vertical boring mills with turret heads. They hold any make or style of reamer with Morse taper shank. A full description with prices is included in the bulletin.

AMERICAN STATESMEN.—The Carborundum Co., Niagara Falls, N.Y., have issued Vol. VII., of American Statesmen series which contains the life history of Benjamin Franklin.

ELECTRIC WELDING.—The Toledo Electric Welding Co., 141 Tenth St., Toledo, in a neat booklet describes the process of electric welding and the various machines. Prices are given showing the cost of electric welding.

CONVEYORS.—Booklets 34 and 34 have been recently issued by the Jeffrey Mfg. Co., Columbus, Ohio. The former deals with wire cable conveyors for various purposes. The latter contains descriptions of many styles of elevator buckets.

POLISHING LATHES.—A pamphlet from Charles Taylor, machine tool maker, Bartholo-

new St., Birmingham, Eng., describes, giving prices, patent ball bearing polishing lathes.

CRANES.—A catalogue dealing with railroad, shop and yard cranes has recently been issued by the Whiting Foundry Equipment Co., of Harvey, Ill., a copy of which may be had on direct application. This publication gives a general outline of the purpose for which cranes are used in railroad yards and shops. The illustrations are reproduced from photographs of actual installations, and cover the entire railroad field. From the handling of complete locomotives and parts thereof to the transfer of freight, very heavy loads are encountered and this company have originated many special designs, including gantry cranes for wheeling locomotives, traveling cranes running on circular track in round-houses and service cranes.

SAND BLAST APPARATUS.—A pamphlet from C. Drucklieb, 178 Washington St., New York, gives directions for connecting and operating the injector sand blast.

CUTTING METALS.—Cutting and welding metals by means of oxygen and hydrogen is the subject of an illustrated booklet issued by the American Oxhydric Co., Milwaukee, Wis. The process is fully explained.

INDUCTION MOTORS.—Bulletin 301 from Allis-Chalmers-Bullock, Montreal, deals with poly-phase Induction Motors. These are described in detail, instalations are shown and in addition controllers, vertical motors are described. The advantages of the induction motor are given in the bulletin.

CUPOLAS.—Foundry Melting Equipment is the subject of a catalogue from George Green & Co., Keighley, Eng., describing cupolas, oil or gas furnaces, blowers, etc. One of the most interesting features is the "Emergency" cupola, instalations of which, have been made in almost every country on the globe, including the British Colonies.

CONTROLLING APPARATUS.—Adams Mfg. Co., 106 New Bond St., London, have issued a series of leaflets, now compiled in book form describing "Igranic" electric motor and dynamo controlling apparatus for direct and alternating current. All apparatus is fully described and illustrated, the volume containing a great deal of information making it a most useful one.

STEAM HAMMERS.—Catalogue 911 from the Buffalo Foundry & Machine Co., East Ferry St., Buffalo, describes fully with illustrations the various types of Bell Steam Hammers.

MOLDING SAND MACHINES.—Catalogue 5 from the Standard Sand and Machine Co., Cleveland, describes their mixers of various types, pulverizers, conveyors, etc.

JET CONDENSER.—A jet condenser giving a vacuum of 28.75 inches of mercury which is so designed that a thorough mixture of exhaust steam and cooling water takes place and at the same time the air present is prevented from pocketing and is delivered to the air pump at a minimum temperature, involves numerous interesting departures in condenser design. These features are brought out, and the general theory of jet condenser construction discussed in a reprint of the article, "A Radical Improvement in Jet Condensers." This booklet is being distributed by the Wheeler Condenser & Engineering Co., of Carteret, N. J.

UNIFORM TORQUE.—A pamphlet entitled, "Arrangement of Engine Cylinders to Produce Uniform Torque" has just been issued by the American Engine Co., of Bound Brook, N. J. This pamphlet contains typical indicator cards taken from the American Ball Angle Compound Engine, and also a derived crank effort diagram. This diagram shows that this type of engine produces a torque which is nearly as uniform as that given by steam turbines, while the steam consumption is considerably less than that of turbines. The booklet also contains a discussion of the crank effort diagram and will be sent free upon application.

BROWNING LOCOMOTIVE CRANES ^{AND} AUTOMATIC BUCKETS

Can be used with profit wherever material is handled



The photograph shows one of the many uses for which our cranes are available. With equipment of this kind, coal, crushed stone or any loose material, can be handled, at the lowest possible labor cost. We also equip these machines with a Lifting Magnet, current for it being generated on the crane by a separate engine. This device has reduced the handling of steel and iron to one-fourth of what it formerly cost by the old method. Considerable data bearing upon material handling problems of different kinds has accumulated in our hands and we invite those interested to consult us. Our Bulletin 35-Y contains many useful hints and is sent free. Write to-day.

The Browning Engineering Company

CLEVELAND :: OHIO

New York

Philadelphia

Pittsburg

Chicago

Birmingham

Kansas City

San Francisco

CALENDAR.—The Detroit Supply Co., dealers in facing, firebrick, foundry supplies and equipment, Windsor, have issued a 1910 calendar, printed in large letters, making it very useful for office use.

CALENDAR.—F. H. Hopkins & Co., Montreal, dealers in railway, contractors' and mining supplies remembered their friends with their usual calendar. It is printed in large type, making it a useful article.

NOTEBOOK.—The Garvin Machine Co., Spring and Varick Sts., New York, have issued their annual notebook containing calendars of 1910-11. It contains a great number of blank pages and very few advertising pages, making a very handy vest pocket notebook.

MACHINERY.—The Garvin Machine Co., Spring and Varick Sts., New York City, have issued an illustrated catalogue of 92 pages, edition G., January 1910. Besides descriptive matter of lathes, grinders, milling machine tools, pulleys, etc., it contains much valuable information in regard to milling, gearing, belting, etc., giving tables of speeds, weights and strengths of materials.

VERTICAL SURFACE GRINDER.—Pratt & Whitney Co., Hartford, Conn., pamphlet, referring to a new type of surface grinder recently brought out by this company. This machine is claimed to grind from 12 to 20 times faster than any other surface grinder, due in part to the cup shape of the grinding wheel, which covers the entire width of the work and insures flatness, together with rapid reduction. The illustrations show the method of fitting pieces to be ground in the machine and also different kinds of work that has been done on this grinder.

PUMPS.—Catalogue No. 6, issued by the Smart-Turner Machine Co., Hamilton, contains illustrated descriptions of the various types of Smart-Turner steam and power pumps including piston, plunger pumps with pot valves, automatic feed pumps and receivers, compound

duplex pumps, triplex power pumps, centrifugal pumps, etc. The accompanying tables give full information in regard to the various sizes of each type.

SMALL D. C. MOTORS.—Small direct current motors have proved their value in every modern industry and are used for a tremendous variety of applications, from running lathes to operating organ blowers. The application of these motors to laundry apparatus, printing presses and other machinery with similar requirements, has brought about changes and improvements in the respective industries which are having an important effect on their development. For this reason a bulletin just issued by the Crocker-Wheeler Company, of Ampere, N. J., describing apparatus of this type, has a vital interest for every up-to-date manufacturer. This pamphlet is well illustrated with half-tone engravings, showing applications of Crocker-Wheeler motors to various types of machinery. It also contains a lot of very interesting and valuable engineering information. A copy will be gladly sent on request. In writing ask for Bulletin No. 118.

BOOK REVIEWS.

ELEMENTS OF MACHINE DESIGN.—By Dexter S. Kimball, A.B., professor of machine design at Cornell University, and John H. Barr, M.S., M.M.E., manager Smith Premier Works. Published by John Wiley & Sons, New York, 444 pages, 5½ x 8½ ins., illustrated. Price \$3.00 net.

The book is the outgrowth of the authors' experience in teaching machine design to the students of engineering at Cornell University. It is not a hand-book, nor is it a manual for the drafting room but a discussion of the fundamental principles of design gathered together and explained in such away and by the aid of illustrative numerical examples as to be of use

as suggesting proper treatment of practical problems occurring daily in the manufacturing world.

The book is prepared with the end in view of developing rational analytical treatment with due regard to practical limitations, and of reducing the analysis to such forms that definite numerical results can be obtained in concrete problems.

ELECTRICAL POCKET BOOK.—Published by Emmett & Co., 65 King St., Manchester, Eng., 270 pages, 4 x 6 ins., illustrated. Price 18 cents, postpaid.

The 1910 issue of the Mechanical World Electrical Pocket Book has been revised, large additions having been made on electric lamps and lighting. The following new sections have been introduced: motor converters, cables, wiring, meters, switches, etc. The book has been printed on thin tough paper reducing the bulk and incidentally reducing postage.

FUEL TESTS WITH ILLINOIS COAL.—Issued as Circular No. 3 of the Engineering Experiment Station of the University of Illinois, presents the results of an elaborate series of tests conducted at the fuel testing plant of the United States Geological Survey. The circular is compiled by L. P. Breckenridge and Paul Disereens. It deals only with coals taken from mines within the State of Illinois. The investigations described include steaming tests under boilers, gas producer tests, washing tests, coking tests, briquetting tests, and tests to determine composition and heating value. From the results stated it appears (1) that the average calorific value of Illinois coal (ash and moisture free) is 14319 B.t.u.; (2) that its evaporating efficiency is but slightly affected by the moisture it contains; (3) that its evaporative efficiency decreases as the ash and sulphur content increases, and that when burned in a hand-fired furnace its evaporative efficiency decreases as the amount of fine coal contained in it increases (4) the performance of Illinois coal in a gas producer compares favorably with that of any other bituminous coal tested at the U.S.G.S. laboratory; (5) one-fourth of all the samples tested may be used for the manufacture of coke; (6) briquetting improves the evaporative efficiency of Illinois coals only when the raw coal is in the form of slack or screenings.

Copies of Circular No. 3 may be obtained gratis upon application to W. F. M. Goss, Director of the Engineering Experiment Station University of Illinois, Urbana, Illinois.

Trade Notes.

Crosier, Stephens & Co., Newcastle-on-Tyne, remembered their customers at New Years with an aluminum envelope opener. Crosier, Stephens & Co. are specialists in aluminum manufacture.

The Skaleoff Co., Montreal, have been appointed Canadian agents for Beldam's Pilot Packing. This packing is one that is especially adapted to the use of superheated steam, being a combination of white metal and asbestos. It is made with a special cloth when for use with ammonia or on pumps.

BECKER STEEL AGENCY.

A neat catalogue on bond paper showing colored labels has been issued by the Becker Steel Co., Philadelphia. This catalogue was sent out by William Abbott, 334 St. James St., Montreal, who has been appointed sole agent for Becker steels in Canada. The line includes high grade tool steels, nickel and tungsten alloy steels and tool steel tubing. Prices are given f.o.b. Montreal, and tables of weights, rules for forging, hardening, grinding, annealing, etc., making a very useful catalogue.

ANNOUNCEMENT

BRUCE PEEBLES

& COMPANY, LIMITED

EDINBURGH - SCOTLAND

are now represented in

CANADA

by

VANDELEUR & NICHOLS

DINEEN BLDG., TORONTO

SPECIALTIES:

**DIRECT and ALTERNATING CURRENT
DYNAMOS and MOTORS for all**

Conditions of Service

PEEBLES-LACOUR MOTOR CONVERTERS

STEAM TURBO ALTERNATORS

TRACTION MOTORS

Some Notes on the Cost of Operating Machine Tools

A Full Knowledge of Costs is Essential in Manufacturing—This Article Reprinted from the Electric Journal gives the Cost of Operating Machine Tools.

By A. G. POPCKE.

In addition to the wages of the machinist, there are other hourly operating expenses which must be charged against each tool in a machine shop. These will be referred to in this article as machine-hour rates. They include a proportional share of the general charges and also specific charges relating to each specific tool. The conditions are somewhat similar to those encountered in central stations. Before competition was very great, it was considered sufficient to figure the cost of generating power from the amount of coal and water consumed, and the wages of the power house attendants. Many industrial plants of considerable size that generate their own power still use this method. Most central station managers, however, have found it necessary, as the demand for power increased and the business became more complicated, to figure more closely and to analyze more thoroughly, all their expenses, among which are interest and depreciation on the cost of all buildings and equipment, salaries of officials, engineering staff, clerk, miscellaneous office expenses and advertising charges.

General Charges.

In a machine shop these charges may be considered under three general heads—fixed charges, variable charges and salaries. They can be determined for a given shop at intervals of a month or more and then divided among the several machines. The best method of making this division depends on so many local conditions that no general rules can be given. If all the tools are doing work of the same general class and are in use approximately the same proportion of the total time, a part of the total general charge can be set off against each tool in proportion to the floor space occupied by both the tool and the material on which it works. The general charge against each tool continues whether the tool is operating or idle, and the method of dividing the general charges must always take this fact into consideration.

Fixed charges include interest, insurance, and taxes on the investment in buildings and auxiliary equipment, such as heating and ventilating systems, fire appliances, benches, cranes, etc. If a shop is rented, the rental must include

the foregoing charges and an additional sum for profit to the owner.

Variable charges include repairs on buildings and equipment to maintain the efficiency, losses due to breakage, defective material, defective design, workmanship, etc.

Salaries include cost of management, superintendence, engineering and designing, clerical work, care of plant, miscellaneous labor, etc.

Specific Charges.

In addition to the foregoing general charges, the cost of operating a tool is affected by the following specific charges which can be determined for each tool:

Interest on the cost of the tool and its auxiliaries.

Depreciation of the tool and its auxiliaries.

Cost of power consumed by the tool.

The interest on the cost of the tool is fairly taken at six per cent. A reas-

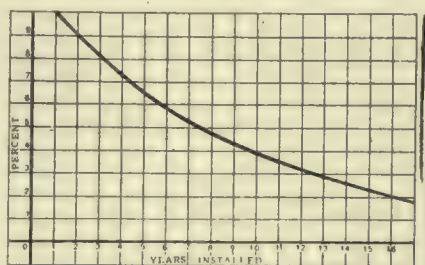

Fig. 1.—Depreciation at 10 per cent. Reducing Balance.

onable method of making allowance for depreciation, in most cases, is to allow ten per cent. of a reducing balance; that is, ten per cent. of the first cost is charged off the first year, then ten per cent. of the remaining cost the second year, and ten per cent. of that remainder the third year, etc. This method is based on the fact that the apparatus actually decreases in value year by year. Allowance for depreciation in any given year can be made by the aid of Fig. 1. This curve gives the per cent. of the first cost corresponding each year to ten per cent. on the reduced balance. For example, the curve shows that the depreciation on a tool that has been in service five years will be 6.6 per cent. of the original cost. If this cost was \$3,800 the allowance for depreciation during the sixth year, ac-

ording to the ten per cent. reducing balance method, is \$3,800 multiplied by 0.066 equals \$250.80. Since this amount is ten per cent. of the reduced cost the value of the tool at the end of the fifth year is \$2,508.

Costs of Power.

Tools for special work which will be discontinued after a comparatively limited period depreciate in value much more rapidly than is indicated by the foregoing method; a special allowance, generally known as utility depreciation, should be made for such tools.

The cost of power for each tool can be obtained by ascertaining the power demand in kilowatts per hour and multiplying this number of power units by the cost per unit and the number of working hours. If power is generated under the shop management, its cost must be determined from the station records; if purchased, the contract price must be used. If the machines are equipped with individual motors records for each class of work may easily be obtained by the use of graphic recording meters. These records will show what the standard conditions should be and what they actually are. Check records may be taken frequently to see that all machines are working at the desired efficiency.

Each machine may be considered as a manufacturing centre and the general charge against it as rental. Each centre receives its material from another, performs some work on it and passes it on with an added value to the next centre. This added value, less the general and specific charges, is the profit accruing to each centre. Since the general charge is continuous, it is evident that each centre must do more than enough work to meet this charge, otherwise it will show a loss; also it is evident that the more work there is done in each centre, the greater the profit.

By determining the costs outlined in Table I and classifying them as in Table II, improvements in operating conditions will suggest themselves and if put into effect, the operating costs can usually be reduced. The data in Table II was obtained by the aid of graphic recording meters in connection with motor-driven machine tools. The data in this table is typical of conditions in many large machine shops. The

CANADIAN MACHINERY

figures given indicate the following division of total operating charges :

- Variable charges from 50 to 55 per cent.
- Salaries from 25 to 30 per cent.
- Interest on cost of machine tools from 5 to 10 per cent.
- Depreciation on cost of machine tools from 5 to 10 per cent.
- Fixed charges 3 per cent.
- Powder 1 per cent.

Table II shows no machine-hour rates less than 48 cents an hour. Usually the machine-hour rates are at least 50 per

erating expenses, the increased earnings by motor operation will be 0.20 multiplied by \$2,470, or \$494 per year.

If both interest at six per cent. and depreciation at ten per cent. be considered, \$494 represents a capitalization of \$3,087; that is, to effect an increase of 20 per cent. in production, this amount could be added to the investment without change of net profit. This mill can be operated by a 7.5 horse-power motor, and the cost of such a motor, including a controller and the

machine tool operation are continually being developed, and should be taken advantage of when any such changes in equipment are being made.

THIS MAY NOT MEAN YOU, BUT—

If you work for a man, in heaven's name, work for him. If he pays wages that supply you your bread and butter, work for him, speak well of him, think well of him, stand by him, and stand by the institution he represents. I would not work for him part of his time, but all of his time. I would give an undivided service or none.

If put to the pinch, an ounce of loyalty is worth a pound of cleverness.

If you must vilify, condemn and eternally disparage, why resign your position, and when you are outside damn to your heart's content. But, I pray you, so long as you are a part of an institution, do not condemn it. Not that you will injure the institution—not that—but when you disparage the concern of which you are a part, you disparage yourself.

And don't forget, "I forgot" won't do in business.—Elbert Hubbard.

cent. greater than the operator's pay. It is perfectly evident from this that consideration of the operator's pay alone gives results far from correct, when the total cost of operation is under consideration.

In some cases it has been found that the introduction of individual motor drive has resulted in an increase of 20 per cent. on production as well as making it possible to obtain accurate data by means of graphic recording wattmeters. To obtain such results, however, the motors must be properly applied and the method of control must be suitable for the service. Machine tool builders are generally prepared to equip old line-shaft driven tools with additional parts to fit them for motor drive; with few exceptions the advantages of motor drive for such machines, if in good condition, are nearly as great as for new machines. Heavier cuts are possible with motors than with line shaft drive, but the old tools are not usually strong enough to permit taking full advantage of this possibility.

The saving to be made by installing an individual motor may be illustrated by assuming that the 60-in. boring mill cited in Table II was shaft driven. The machine-hour rate is \$0.53, and if the workman receives \$0.35 per hour, the total operating cost is \$0.88 per hour, or \$2,470 per year of 2,808 hours (54 hours per week). This machine if properly equipped for motor drive will give at least 20 per cent. increased output with practically no increased operating cost. Assuming that the machine's earnings are only enough to cover op-

necessary changes in the machine, would amount to possibly \$500 or about one-sixth the warranted investment. From the other point of view, the interest and depreciation on \$500 at 16 per cent. is \$80, which deducted from the total saving, \$494, effected by the motor drive, leaves \$414 per year net gain.

In some cases the conditions will warrant the installation of a complete new

A very ingenious method of overcoming the friction of intermeshing gears has recently been devised. The gear-teeth are electro-magnetically held in engagement, without actually contacting. The teeth of the driving-gear are mag-

TABLE I.—LIST OF GENERAL AND SPECIFIC CHARGES AGAINST MACHINE TOOLS.

General Charges Against Total Shop.	Charges Against Each Machine Tool.
Fixed Charges: Interest and depreciation on buildings and accessories.	Proportional share of total fixed charge.
Variable Charges: Repairs and renewals. General operating expenses.	Proportional share of total variable charge
Salaries: Supervision. Engineering. Clerical.	Proportional share of total salaries.
	Interest on cost of tool. Depreciation on cost of tool. Cost of power for tool.

TABLE II.—MACHINE HOUR RATES—EXPRESSED IN DOLLARS.

Type of Machine.	Charges per hour in dollars.						Total, or Mach-Hr. Rate.
	Fixed.	Vari-able.	Salaries.	In-terest.	*Deprecia-tion.	Power.	
Vertical Boring Mills—							
40 inches to 60 inches.....	0.02	0.25	0.15	0.05	0.05	0.01	0.53
72 inches to 100 inches.....	0.04	0.45	0.25	0.08	0.08	0.01	0.91
12 feet to 14 feet.....	0.05	0.80	0.40	0.15	0.15	0.02	1.57
16 feet to 24 feet Ext.....	0.08	2.00	1.00	0.30	0.30	0.03	3.71
Av. percent of total.....	3	52	28	8	8	1	100
Radial Drills—5 feet.....	0.02	0.30	0.20	0.03	0.03	0.01	0.59
Radial Drills—10 feet.....	0.04	0.60	0.35	0.09	0.09	0.01	1.18
Av. percent of total.....	3	51	31	7	7	1	100
Engine Lathes—30 inches to 40 inches	0.02	0.25	0.12	0.04	0.04	0.01	0.48
Engine Lathes—40 inches to 60 inches	0.03	0.50	0.25	0.10	0.10	0.01	0.99
Av. percent of total.....	3	51	25	10	10	1	100
Planers—36 inches to 56 inches.....	0.04	0.55	0.30	0.05	0.05	0.01	1.00
Planers—7 feet to 10 feet.....	0.06	1.10	0.60	0.15	0.15	0.02	2.08
Planers—12 feet to 14 feet.....	0.15	2.60	1.40	0.25	0.25	0.03	4.68
Av. per cent of total.....	3	55	30	5.5	5.5	1	100

*It is assumed that machines have been installed six years, so that the depreciation is six per cent on basis of ten per cent reducing balance. See Fig. 1.

equipment instead of equipping the old tool with a motor. The new tool will require increased investment, but will make possible more rapid work by taking heavier cuts, thereby warranting the investment. Whether to equip an old machine with a motor or to install a new motor-driven tool is a question calling for careful consideration in order to obtain the best results, as improved methods of applying motors to

netised by means of suitable coils, while the teeth of the driven gear serve in pairs as armatures for the magnetised teeth. Of course, such an arrangement would hardly be suitable for slow, heavy work, because the cost of current would be greater than that of lubricating-oil and the loss due to friction, but for light, high-speed work the electro-magnetic engagement would undoubtedly prove very advantageous.

Grinding Wheels—Their Manufacture and Uses

Modern Grinding Wheel Practice: Mounting Wheels: Why a Grinding Wheel Cuts. From an Illustrated Talk at McGill University, Feb. 9, 1910

By E. W. DODGE

Alundum, the grit or cutting material used in the manufacture of Norton grinding wheels, is made from bauxite, a hydrate of alumina. The electric furnace purifies it and the analysis of alundum will run nearly as high as the ruby in crystalline aluminum oxide, and the high-

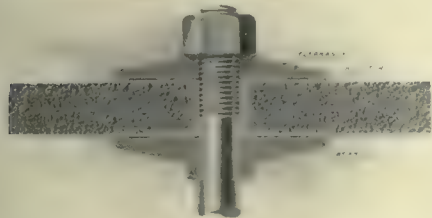

Correct Method of Mounting a Wheel, showing Flanges One-half the Diameter and Properly Relieved.

er the crystalline aluminum oxide, the greater its cutting efficiency as an abrasive.

The base of the abrasive qualities of emery and corundum is crystalline aluminum oxide. Emery contains from 35 to 40 per cent impurity in the form of iron, silica and lime. Corundum is practically a pure aluminum oxide, but is never obtained in its pure state, on account of the matrix in which it is found.

The efficiency of an abrasive does not always depend on its hardness. The resistance of its grain to fracture is its most important property. This should be proportionate to the pressure at which it is to be used. In internal grinding, where the wheel is small and mounted on the end of a slim spindle, we not only use a weak bond, but also an abrasive that will fracture easily. If the grain itself did not break so as to leave new cutting surfaces, it would be impossible to do good and fast work on account of glazing and heat.

On heavy work, such as steel castings where large wheels are used and pieces weighing from 45 to 100 pounds are thrown against them, we must have a tough abrasive that will not break down until we have reached the glazing point.

This range of toughness of grain is known by us as "temper," and an abrasive which cannot be made in different degrees of temper is not adapted to all classes of grinding.

In the making of alundum, manipulation of furnace and the mixtures which are used in it give us all the tempers required.

The mineral bauxite is a hydrate of alumina containing one-third water of

combination. The water is expelled by the means of a rotary calciner, the cylinder of the calciner shown here being 60 feet in length and is heated by two gas producers, and the material being fed in from the end farthest from the fire. The material is discharged, free from water, at the producer end. The machine is continuous and will calcine 40 tons of bauxite daily.

After calcining, the ore is ready for the electric furnace. These furnaces are conical-shaped pots, which stand on a car and heated by two vertical electrodes, which are gradually raised as the molten bauxite fills the furnace. 2200 electric horse-power is used in the furnace room. When the fusion is complete, the furnace is pushed out under an electric crane, the product lifted off and placed on the cooling floor until cold enough to handle. The fusions contain about three tons of abrasive material.

In the scheme of reduction to prepare alundum for manufacture into wheels, it is passed through a series of crushers, rolls, roasters, washers, dryers and grading sieves. It must be crushed and graded to a great many sizes, which are designated by numbers ranging all the way from 10 to 200. Finer materials than No. 200 grain are called flours. The flours are used largely in rubbing and sharpening stones, razor hones, etc. The grains are numbered according to the meshes per linear inch through which they have passed in grading. By No. 30 grain is meant the size

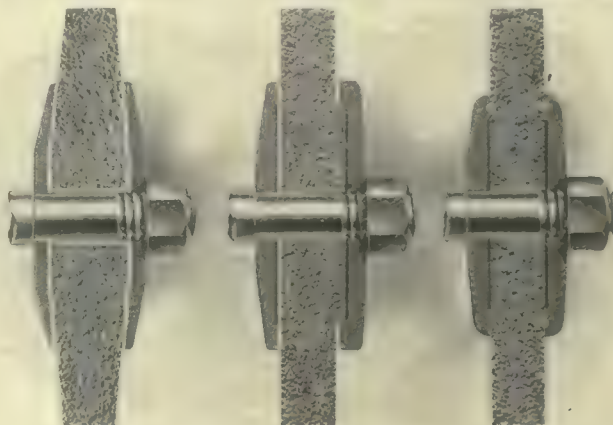

Three Types of Protection Flanges.

that will pass through a grading sieve having 30 meshes to the linear inch; No. 20 grain, 20 meshes, etc.

Truing is done by means of cutters of stamped steel or chilled iron, and on fine wheels or where sharp corners are desired diamonds are used.

Testing Wheels.

Norton alundum wheels are tested immediately before shipment at approximately 10,000 surface feet per minute. The testing is done on motor-driven machines equipped with variable speed motors, the revolutions per minute being indicated by tachometers. The bursting limits of all grinding wheels vary in proportion to their grade of hardness. Breakages do not occur in grinding wheels made by standard makers from any inherent weakness they may contain, but rather from insufficient care taken in their use and mounting.

The most common causes of accidents are: Catching of work between wheel and rest; mounting them between flanges that bear unevenly when nut is tightened; not using any flanges and simply screwing a nut against the wheel; allowing the arbors to become loose in the boxes from wear; allowing wheels to get out of truth.

All wheels are tested against standard wheels to establish their grade of hardness, special machines being used for this purpose. Every wheel is thoroughly inspected before shipment by an inspection department, and no wheel can be shipped without having passed this department and without the signature of the inspector on the order check.

Grits and Grades.

Grinding wheels are made in many combinations of grain and grade to meet the variety of conditions under which they are used. The shipping tag of each wheel bears a number and grade letter. For example, 30-M; thirty designates that No. 30 grain was used in the manufacture of that wheel. The letter of the alphabet designates the grade of hardness, which grade is determined by skilled graders, with the aid of grading machines. When the retentive properties of

the bond are great, the wheel is called "hard"; when the grains are easily broken out it is called "soft." A wheel is of the proper grade when its cutting grains are automatically replaced when dull. Wheels that are too hard glaze. Dressing re-sharpens them, the points of

the dresser breaking out and breaking off the cutting grains by percussion.

Soft wheels are used on hard materials, like hardened steel. Here the cutting particles are quickly dulled and must be renewed. On softer materials, like mild steel and wrought iron, harder grades can be used, the grains not dulling so quickly.

The area of surface to be ground in contact with the wheel is of the utmost importance in determining grade. If it is a point contact, like grinding a ball, or an extremely narrow fin is to be removed, we must use a very strongly bonded wheel, on account of the leverage exerted on its grain, this tending to tear out the cutting particles before they have done their work. If we have a broad contact, like grinding a hole or where the work brings a large part of the wheel into operation, the softer grades must be used, because the depth of cut is so infinitely small that the cutting points in work become dulled quickly and must be renewed, or the wheel glazes and loses its efficiency.



Protection Hood.

Vibrations in grinding machines cause percussion on the cutting grains, necessitating harder wheels. Wheels mounted on rigid machines can be softer in grade and are much more efficient.

Running speed in practice are from 4,000 to 6,000 surface feet, depending on work, condition of machine, and mounting. Generally speaking, grinding of tools, cutters and surface grinding, is done at about 4,000 to 5,000 feet. Snagging and rough forms of hand-grinding are done at 5,000 to 6,000 feet. Cylindrical grinding, or where the work is rigidly held and the wheel feed is under control, is done at from 5,500 to 6,500 feet, and in some instances as high as 7,500 feet. These speeds apply to vitrified, silicate and elastic wheels.

Mountings.

Users of grinding wheels are beginning to realize the importance of mounting them in a safe and proper manner. Fig. 1 shows flanges one-half the diameter of the wheel properly relieved so as to bring the bearing of the flange as far out on the diameter of the wheel as

possible. The rubber washers tend to take up any imperfections in the wheel or flange.

The three types of protection flanges shown are good if properly designed. The criticism of all protection flanges is that they do not prevent that part of the wheel outside of the flange from flying in case of accident. Probably the best protection for a grinding wheel is the protection hood shown. This device prevents pieces of wheel from flying all over the shop and protects the vital parts of the operator's anatomy.

Before starting up the machine after a new wheel has been mounted, care should always be taken that the belt has been shifted to the proper pulley. As a grinding wheel decreases in diameter, in order to maintain the same surface speed the belt should be shifted to a smaller pulley. The belt should never be left on the smaller pulley, however, when mounting a new wheel of larger diameter. In places where many wheels are used, instead of shifting the belt two or three sizes of machines are used and when the wheel is worn down to a certain diameter, it is changed to a machine with higher speed.

It is well to remember that the efficiency of any grinding wheel is proportionate to its periphery speed. The following notice is used in many places with good results, it being posted directly on front of the machine:

- Machine Number.....
- Spindle Revolutions.....
- Diameter of Grinding Wheel not over
- inches.
- Take off Wheel at
- inches.
- Notify Foreman when Wheel needs Dressing.

In connection with this, it is good practice to have one man mount, change belts and dress all wheels.

Machines should also be equipped with dust systems. There are many grinding rooms in our older shops where the machines are placed in rooms without ventilation or light. Grinding rooms should necessarily be well ventilated on account of the dust. The dust system prevents wear and tear on the shafting, machinery and belts. It makes the grinders feel better and the man is just as efficient as he feels. Machines on foundations are much less liable to vibration and lack of vibration means wheel economy.

Why a Grinding Wheel Cuts.

Some idea of the reason why a grinding wheel can cut work to size in less time than the same work can be sized by the turning tool may be had when it is known that a 24x4-ft. wheel, when used on a modern machine, will remove approximately one billion, eighty-six million, one hundred and seventy-one thousand (1,086,171,000) chips per minute. It

has been figured out that there are approximately one million, eighty-six thousand, one hundred and seventy-one (1,086,171) cutting points on the wheel face each cutting off a chip one thousand times per minute.

There seems to be considerable misunderstanding in the mechanical world as to what is going on when a grinding wheel is removing stock. One very often hears the expression, "This wheel cuts; it does not grind," the intention being to impress the hearer with the thought that that particular wheel has in it some virtue of cutting which other grinding wheels have not.

It is, of course, true that many wheels cut poorly, due to improper grain and grade. So do many tools which have not been correctly tempered. Because some of the cutting particles of grinding wheels are blunt or even round does not prevent their cutting.

We can all remember when we could not conceive of a lathe-tool as capable of cutting unless it had a sharp and raking edge. But modern high-speed steels have shown us that tools without sharp edges or sharp points cut off the greatest quantity of chips in the shortest time. The material of these steels and their proper heat treatment for cutting high speeds is the secret of their success.

So with grinding wheels. The material removed by a good grinding wheel is removed in the same manner as by the turning tool. It is cut just the same. With the grinding wheel, the chips are so very small that we do not recognize them as such without the aid of the microscope. The microscope clearly shows them to be shavings identical with the cuttings from steel tools, except that they are of many different shapes and angles of clearance. Some have a raking cut, some a dragging cut. In dry grinding, the chips are generally discolored from the heat. If the wheel is too hard, we find the grindings full of globules and molten metal.

Wet grinding gives us better-shaped chips and of about their natural color, indicating that the water has served to lubricate and to keep the cutting edges of the grain sharp and the work cool.

Examination will show a difference in chips of the same grade of steel ground dry from those produced by wet grinding. The chips from dry grinding usually show globules of molten steel, while those produced by wet grinding are more regular, and about the natural color of the metal.

Manganese steel is a hard and tough material which cannot be touched with any kind of a turning tool and, unless an abundance of water is used, when grinding, we get burned chips.

The Design of Bevel Gears ; Shafts Acute and Obtuse

Part II. on the Design and Manufacture of the Varians Types of Gears,
Giving Information and Tables of Great use to Mechanical Men.

By G. D. MILLS

This article introduces a method for the calculation of all bevel gears other than those with shafts at right angles, which has been described in Part I. The method with which the centre angles are calculated, and from which the formulas are derived, can be better understood by referring to Fig. 2. The diagram contains the two half-pitch diameters drawn at an angle which is always 180 degrees minus the angle of shafts, and the two shaft-centre lines form the balance of the quadrilateral figure, the corners of this figure have been connected by two straight lines, one of

to l, thus making a right triangle pnt tangent a or tangent c, is therefore the distance nl divided by the distance np, while the lengths nl and nk may be readily found by multiplying the half-pitch diameter of pinion by the sine and cosine of angle e, which is equal to the

angle of shafts L , and from which is derived the formula for shafts acute.

$$N_2 \sin L$$

$$\text{Tangent } C = \frac{N_2 \sin L}{(N_2 \cos L') + N_1}$$

(I have substituted the number of teeth in place of pitch diameters, as in part

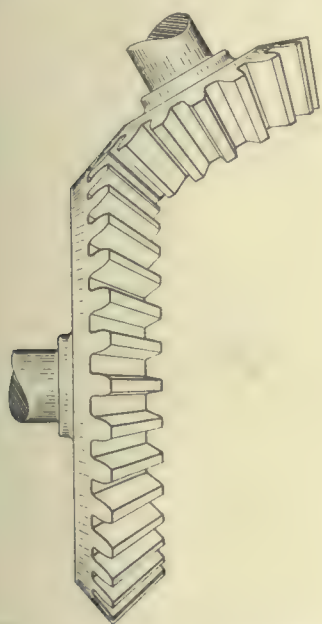
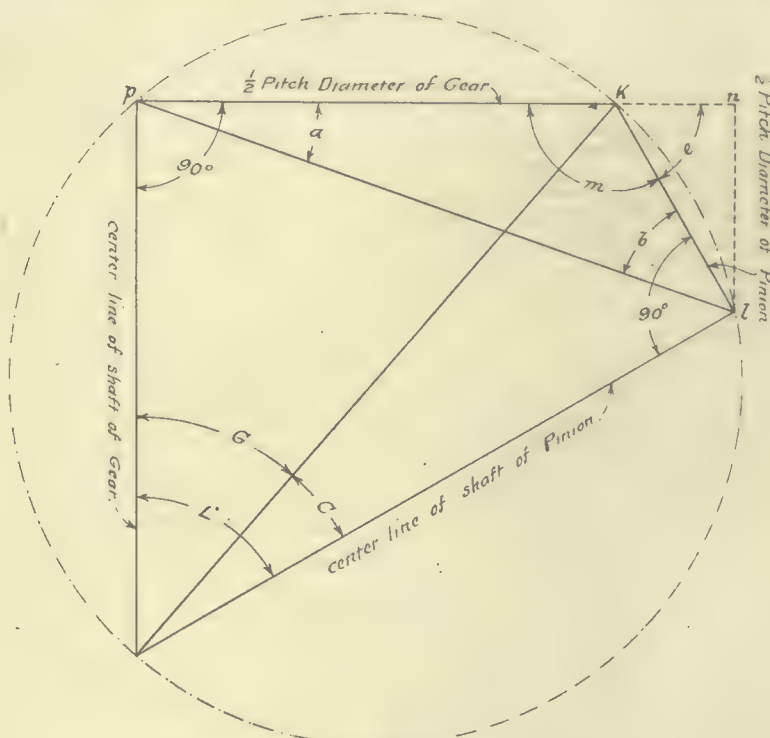

Fig. 1.—Pair of Gears, Shafts Acute.

which is the diameter of the enclosing circle, divides the angle of shafts, and runs through the centre of working depth of teeth, as they mesh.

A careful inspection of Fig. 2 reveals the fact, that in order to determine either centre angle G or C , we have but to calculate angle b or angle a , and since the included angle m is always 180 degrees minus the angle of shafts L , we have the included angle and two sides, viz: the two half-pitch diameters, with which we may proceed with the operation of calculating angle a . In the right hand corner of Fig. 2, the half-pitch diameter of gear has been extended to n and a perpendicular erected



L = Angle of Shafts
 G = Center Angle of Gear = angle "b"
 C = " " " Pinion = "a"
 m = included angle of Pitch Diameters = $180^\circ - L$
 e = supplement of angle m = angle of shafts " L "

Fig. 2.—Calculating Angles.

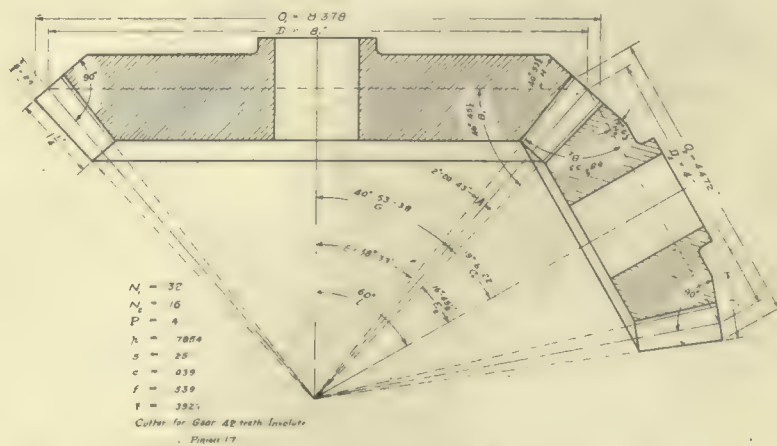

$N_1 = 32$
 $N_2 = 16$
 $P = 4$
 $h = 7874$
 $s = 28$
 $c = 039$
 $f = 539$
 $F = 392$

Cutler for Gear 42 teeth Involute
 Pinion 17

Fig. 3.—Pair of Bevel Gears, Shafts Acute.

l.). Angle G is found by deducting angle C from angle of shafts L.

When shafts are at an obtuse angle, however, the included angle m is obliged to be acute and another formula required to calculate angle C, this is explained later on, there being but two formulas necessary to calculate the centre angles of shafts acute and obtuse, and from these angles all other angles may be readily found. Fig. 2 is arranged with shafts acute. A diagram of shafts obtuse presents a somewhat different quadrilateral figure, and the figure is still more complicated in broad obtuse shafts. The method, however, is correct for all three, it is proved in the 6th Book of Euclid, proposition

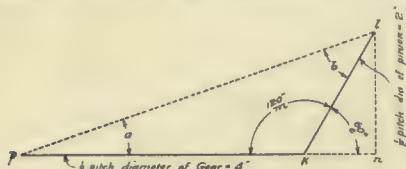

Fig. 4.—Calculating Gears, Shafts Acute.

33-c, also 3rd Book of Euclid proposition 21. I have deemed it expedient to prove the method, that the formulas may be followed with confidence.

Only a few years ago many gear manufacturers obtained their angles by measuring the drawing with a protractor, which method has, however, proved unreliable, and the necessity of calculating the angles, apparent.

In the three examples which follow, are arranged a pair of gears with acute shafts, and two pairs with obtuse shafts; together with a mode of procedure, which can be relied upon, to give absolutely correct results in every case.

Fig. 3 contains a pair of bevel gears with shafts at an acute angle, and following are a list of formulas necessary

for their calculation. We shall proceed as in Part I. Shafts at right angles, and the same tooth formulas may be used, The diameter of blank, angle increment

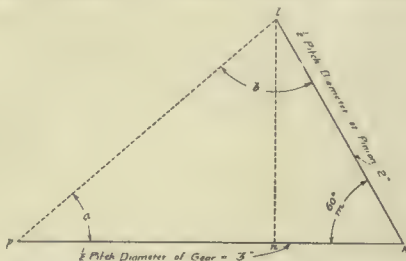

Fig. 6.—Calculating Angles, Shafts Obtuse.

cutting angle, angle of edge, and number of teeth to select cutter from are as in 90 degree shafts. The angle of blank, however, must be found separately for each wheel, by deducting from 90 degrees the sum of the centre angle and angle increment, and the centre angles calculated first by the formulas for acute shafts.

TABLE OF FORMULAS FOR ACUTE SHAFTS,

L=angle of shafts.	G=centre angle of gear=angle of edge of gear H.	G=L-D
C= pinion M.	tan D= $\frac{N_2 \sin L}{(N_1 \cos L) + N_2}$	
A=angle increment	tan A= $\frac{D \sin C}{(D \cos C) + A}$	
E=cutting angle of gear	E=G-A	
E ₁ = pinion	E ₁ =C-A	
B=angle of blank of gear	B ₁ =90°-(G+A)	
B ₂ = pinion	B ₂ =90°-(C+A)	
O ₁ =diameter of blank of gear	O ₁ =(2 s cos G)+D ₁	
O ₂ = pinion	O ₂ =(2 s cos C)+D ₂	
	Number of teeth to select Cutter for Gear = $\frac{N_1 \sin L}{\cos C}$	
	Pinion = $\frac{N_2}{\cos C}$	
N ₁ =number of teeth in gear	see table of tooth formulas	
N ₂ = pinion		
D ₁ =pitch diameter of gear		
D ₂ = pinion		
s=addendum		

Our angle of shafts is to be 60 degrees, and we shall select, as in Part I, 32 and 16 teeth 4-pitch and our tooth dimensions may be calculated as before, they will be found noted on Fig. 3. Before calculating the centre angles, let us briefly review Fig. 2. It has been proved that angle a is equal to angle C, and that the included angle m is always 180 de-

grees minus the angle of shafts L, consequently our formula only deals with the upper portion of Fig 2, which will be found in Fig. 8. Therefore tangent a or tangent C=

$$N_2 \sin. L \quad 16 \times .866 \quad = .3464$$

(N₂ cos L)+N₁ (16×.5)+32
and its angle is 19 degrees—6'—22''
=H₂. Angle G is obtained by deducting angle C from angle of shafts L or 60 degrees minus 19 degrees—6'—22''=40 degrees—53'—38''=H₁. Angle increment is found as in 90-degree
sin C .3273

shafts, tangent A= $\frac{.3273}{.8}$
.0409, and its angle is 2 degrees—20'—43''. From these angles the others are readily found.

Cutting Angles.

The cutting angle of gear E₁=G—A or 40 degrees—53'—38'' minus 2 degrees—20'—43''=38 degrees—33'. The cutting angle of pinion E₂=C—A or 19 degrees—6'—22'' minus 2 degrees—20'—43''=16 degrees—45½'. Angle of blank of gear B₁=90 degrees—(G+A) or 90 degrees minus (40 degrees—53'—38'' plus 2 degrees—20'—43'')=46 degrees—45½'. Angle of blank of pinion B₂=90 degrees—(C + A) or 90 degrees minus (19 degrees—6'—22'' plus 2 degrees—20'—43'')=68 degrees—33'. It will be noticed that the centre angles and angle increment have been calculated to seconds, in order to determine the other angles in degrees and minutes, as correct as possible. The above angles have also been noted on Fig. 3, in their proper place, and we may proceed to calculate the diameter of blanks and size cutters to select. As in Part I. 90-degree shafts, we have been obliged to wait until the angles were calculated. The diameter of blank of gear O₁=(2 s, cos G)+D₁=(2 × .25''×.7559)+8''=8.378 inches, and the diameter of blank of pinion O₂=(2.s. cos C)+D=(2×.25 ×.9449)+4''=4.472 inches. The number of teeth to select cutter for gear=

$$\frac{N_1}{\cos G} = \frac{32}{.7559} = 42, \text{ or a 4 pitch involute bevel gear cutter, which will cut 42 teeth. The number of teeth to select cutter for pinion} = \frac{N_2}{\cos C} = \frac{16}{.9449} = 17$$

or a 4-pitch involute bevel gear cutter, which will cut 17 teeth.

Shafts Obtuse.

We may proceed with the calculations of shafts obtuse. In the diagram, Fig. 5, are arranged a gear and pinion with shafts at an angle of 120 degrees. We shall select a speed ratio of 1½ to 1 or 24 and 16 teeth 4-pitch from which the

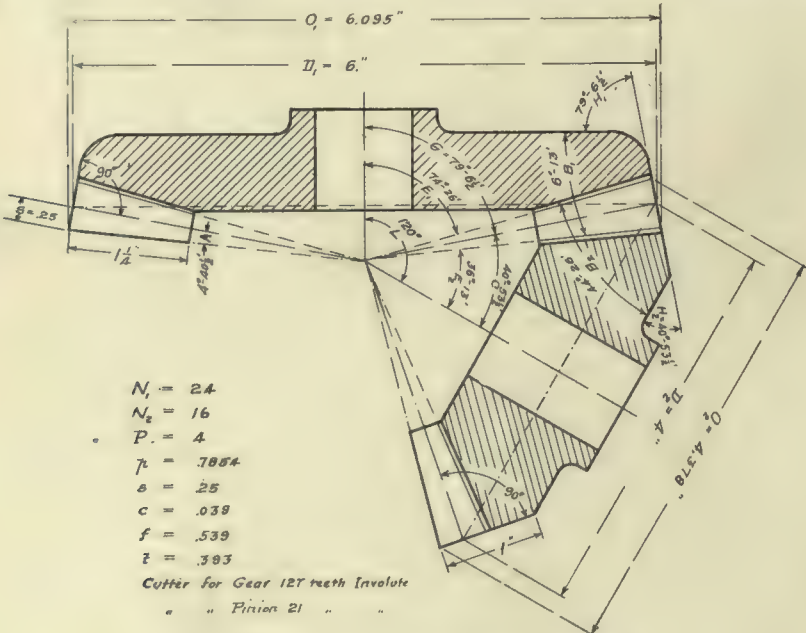

- N₁ = 24
- N₂ = 16
- P = 4
- γ = 78.54
- s = .25
- c = .039
- f = .539
- z = .393
- Cutter for Gear 12T teeth Involute
- " " Pinion 21 " "

Fig. 5.—Bevel Gears, Shafts Obtuse.

tooth dimensions may be calculated as before, they are noted on Fig. 5.

In calculating the centre angles of obtuse shafts, we shall require another formula. The upper portion of a diagram of obtuse shafts similar to Fig. 2, would appear as in Fig. 6.

As before, we have two sides, and the included angle m, which is acute, when shafts are at an obtuse angle. Tangent a, or tangent C may be readily determined by dividing the distance ln, by the distance np and the lengths ln and nk found by multiplying the half pitch diameter of pinion by the sine and cosine of angle of shafts L, which is the sine and cosine of its supplement, or sine and cosine of angle m. From this is derived the formula for obtuse shafts.

$$N_2 \text{ sine } L = 16 \times .866$$

$$\text{Tangent } C = \frac{N_1 - (N_2 \cos L)}{24 - (16 \times .5)} = .866, \text{ and its angle is } 40 \text{ deg.} - 53\frac{1}{2}' = H.$$

Centre angle $G = L - C$ or 120 de-

26'. These angles have been noted in their proper place on Fig. 5, and we may conclude our calculations for obtuse shafts, by determining the diameter of blanks and size cutters to select.

The diameter of blank of gear $O_1 = (2. \text{ s. } \cos G) + D_1 = (2 \times .25'' \times .1889) + 6'' = 6.095$ inches. The diameter of blank of pinion $O_2 = (2. \text{ s. } \cos C) + D_2 = (2 \times .25 \times .7559) + 4'' = 4.378$ inches. The number of teeth to select cutter for gear—

$$N_1 = 24$$

$$\frac{\cos G .1889}{\text{bevel gear cutter, which will cut 127 teeth.}}$$

The number of teeth to select cutter for pinion—

$$N_2 = 16$$

$$\frac{\cos C .7559}{\text{or a 4-pitch involute bevel gear cutter, which will cut 21 teeth.}}$$

These have been noted on the diagram, Fig. 5, which completes the calculations.

In bevel gears with shafts at an obtuse

sine C .6192

$\frac{1}{2} N_1 = 8$
 4 degrees—25½'. The cutting angle of the interior gear $E_1 = G - A = 111$ degrees—44½' minus 4 degrees—25½' = 107 degrees—19'. This angle, however, cannot be used to set our gear cutter or milling machine, as our graduations only extend to 90 degrees. The angle to set is, therefore, its supplement, or 180 degrees minus 107 degrees—19' = 72 degrees—41'. Cutting angle of pinion $E_2 = C - A = 38$ degrees—15½' minus 4 degrees—25½' = 33 degrees—15''. The angle of blank of gear B_1 , we are obliged to make the included angle between the edge line and face of teeth in a wheel of this description, that it may readily serve its purpose in trying the blank with a protractor B_1 , therefore equals 90 degrees—A = 90 degrees minus 4 degrees—25½' = 85 degrees—34½'.

Angle of blank of pinion B_2 is as before, 90 degrees—(C+A) = 90 degrees minus (38 degrees—15½' plus 4 degrees—25½') = 47 degrees—19'. Those angles will be found noted in their proper place on Fig. 7, and we may conclude our calculations for this pair of gears by determining the diameter of blanks, and number of teeth to select cutters from. In the case of the interior gear, the distance across the bottom of blank or diameter of point of tooth circle, is found to be within the space necessary to construct the blank; while it has formerly served as the outer diameter. This distance is equal to $D_1 - (2. \text{ s. } G = 6'' \text{ minus } (2 \times .25_1'' \times .3704) = 5.815$ inches. The edge line may be turned from this circle outward at an angle of 111 degree—44½', or (centre angle G) with respect to the horizontal or bottom of blank.

We must, however, first find the diameter of blank, and may proceed, as in former cases, $O_1 = (2. \text{ s. } \cos G) + D_1 = (2 \times .25 \times .3704) + 6'' = 6.185$ inches. This diameter will be found to be inadequate to properly extend the edge line and round the corners in this style of a wheel, and we shall have to add as much more to the pitch diameter, or (.185×2) + 6'' = 6.37 inches, which will be our diameter O_1 . The diameter of blank of pinion is as before $O_2 = (2. \text{ s. } \cos C) + D_2 = (2 \times .25 \times .7852) + 4 = 4.393$ inches. The number of teeth to select cutter for

$$N_1 = 24$$

$$\frac{\cos G .3704}{\text{gear}} = 65 \text{ teeth and the}$$

$$N_2 = 16$$

$$\frac{\cos C .7852}{\text{number of teeth to select cutter for pinion}} = 20 \text{ teeth, and they have}$$

been noted in their proper place on Fig. 7.

Continued in April Issue.

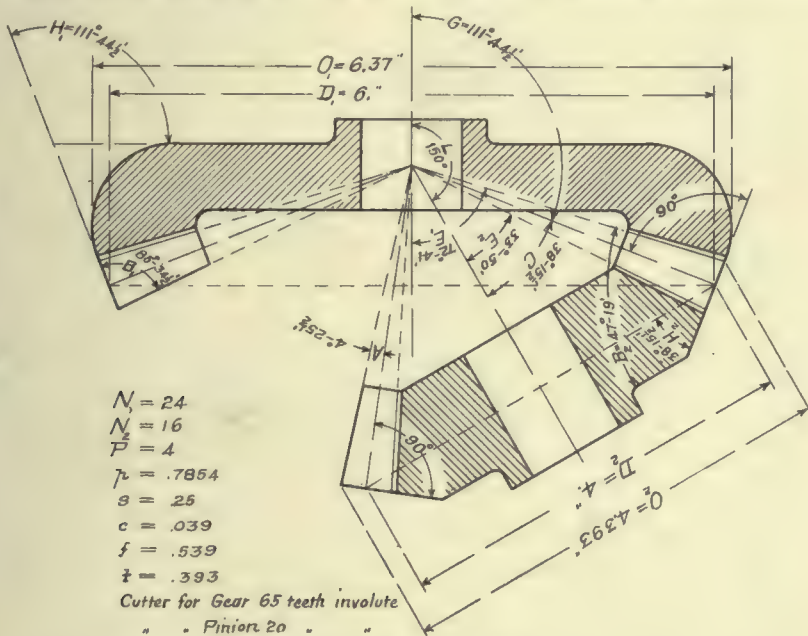

Fig. 7.—Interior Gear.

degrees minus 40 degrees—53½' = 79 degrees—6½' = H_1 . The other angles may be calculated as in shafts acute, and the same formulas used. Tangent of angle

$$\text{sine } C = .6546$$

$$\text{increment } A = \frac{1}{2} N_2 = 8$$

and its angle is 4 degrees—40½'. The cutting angle of gear $E_1 = G - A = 79$ degrees—6½' minus 4 degrees—40½' = 74 degrees—26'.

Cutting angle of pinion $E_2 = C - A = 40$ degrees—53½' minus 4 degrees—40½' = 36 degrees—13'. The angle of blank of gear $B_1 = 90$ degrees—(G+A) = 90 degrees minus (79 degrees—6½' plus 4 degrees—40½') = 6 degrees—13'. Angle of blank pinion $B_2 = 90$ degrees—(C+A) = 90 degrees minus (40 degrees—53½' plus 4 degrees—40½') = 44 degrees—

angle, there is another condition, which frequently arises when shafts are broadly apart, viz.:—the gear becomes what is known as an interior gear. In the diagram, Fig. 7, we have this peculiarity.

The angle of shafts L, Fig. 7, is 150 degrees, and we shall select 16 and 24 teeth 4-pitch, as before; from which we obtain the same tooth dimensions, and they are noted on Fig. 7. Our centre angle is calculated as before, with the formula for obtuse shafts. Tangent C =

$$N_2 \text{ sine } L = 16 \times .5$$

$$\frac{24 - (16 \times .866)}{\text{and its angle is } 38 \text{ degrees} - 15\frac{1}{2}' = H_1}$$

centre angle $G = L - C = 150$ degrees minus 38 degrees—15½' = 111 degrees—44½' = H_1 . The tangent of angle increment A

MACHINE SHOP METHODS ^A_N^D DEVICES

Unique Ways of Doing Things in the Machine Shop. Readers' Opinions Concerning Shop Practice. Data for Machinists. Contributions paid for.

TOOL REST FIXTURE.

By Frank E. Booth.

Some time ago the writer had occasion to bore three small cylinders, on the face plate of lathe. The job was such that it was necessary to have a long

tool holder slot, which acts like a V block. By loosening off clamps the tool can be turned to suit operator, and when tightened down, gives a good solid hold. This is a handy fixture for shops where a variety of jobs are being done,

on the end of the pin, thus drawing the pin D against the inside lug of the plate A. The plates may easily be set parallel, at right angles or at any spe-

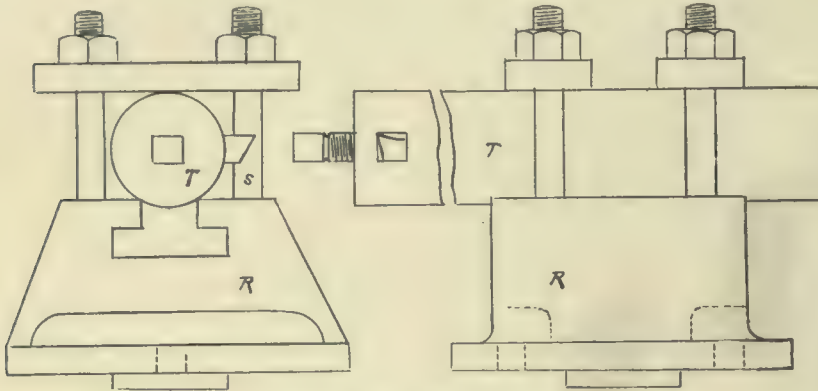

Fig. 1.—Arrangement of Tool.

rigid boring tool in order to machine certain parts properly. The lathe being equipped with an ordinary tool holder as represented in Fig. 2, allowed the use of only a moderately sized tool.

The difficulty was overcome in the

such as job work, and it takes but a short time to rig it up.

Fig. 3 shows a good way to clamp cylindrical work to the machine table, when V blocks are not to be had. Two pieces of round, straight stock A and B as long or longer than the job, are laid in the slots of table and work placed, as shown in the sketch and clamped down.

The two pieces A and B act as a V

ial angle for work to be done by using index pins.

Figs. 1 and 2 show the plates in use on a planer, the shaded portions being

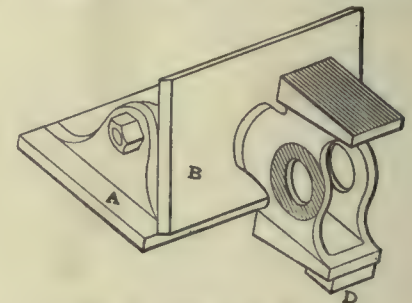

Fig. 2.—Angle Plate in Use.

machined. The plates are used to secure the right angle, and the work is blocked in Fig. 2, by the insertion of a small block D. After machining one side,

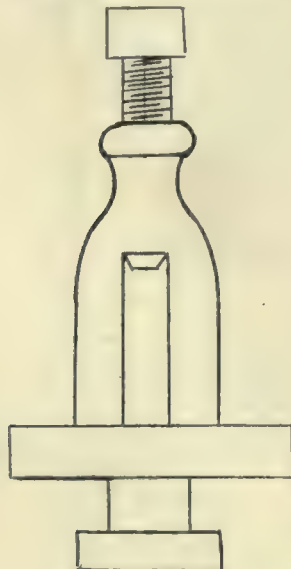

Fig. 2.—Tool Post.

manner shown in Fig. 1. In the sketch, the part marked R represents the solid tool rest which takes the place of the compound rest on the lathe.

Four holes were drilled and tapped in the top face of this casting, and studs were inserted, as shown in sketch. A tool as large as required could then be clamped as shown in Fig. 1, lying in

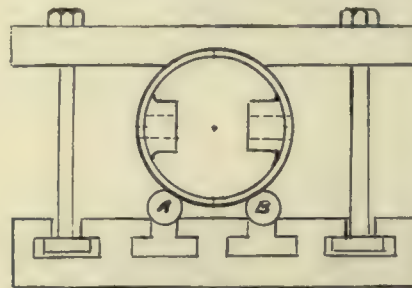

Fig. 3.—Clamping Cylindrical Work.

block, and are much quicker to handle than the ordinary V blocks. They hold the work parallel to the traverse of table requiring no adjusting in that direction, while setting up the job.

ANGLE PLATE.

A convenient angle plate has been devised by Robt. McKechnie, superintendent of the Smart-Turner Machine Co., Hamilton, which is giving good service. The dimensions of the one principally used by them are given in Fig. 1.

The two plates are locked together in any desired position by tightening the nut

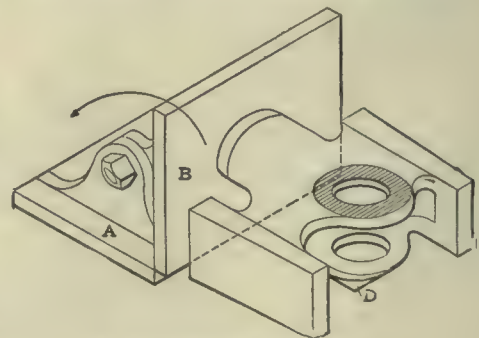

Fig. 3.—Angle Plate in Use.

the crosshead is then turned half way around without changing the angle plate.

In Fig. 3, the sides to be machined are parallel. The plates are set at 90 de-

grees, and when one side is planed one plate is swung in the direction of the arrow, and the other side is machined. The work is blocked up at D. This convenient angle plate has a variety of uses, the one illustrated being only an example.

TOOL FOR PLANER.

By Wm. Silk.

The tool illustrated in Fig. 1 is used to plane underneath saw carriages. An idea may be obtained of the work ob-

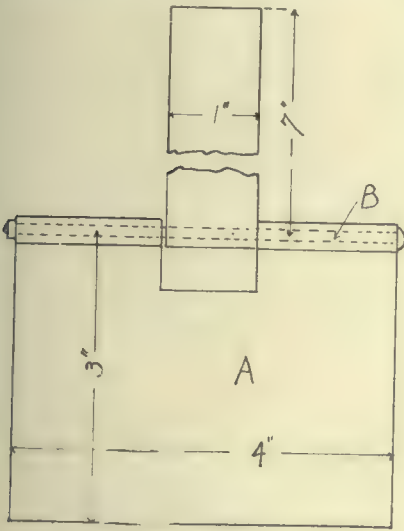

Fig. 1. Tool for Planer.

tained by a reference to Fig. 2 which shows a sectional view of a saw carriage. I designed this simple jig some time ago, making it from sheet iron and it has given good service ever since.

The tool rests on A and planes underneath. Then it catches on the end of the work and rides on top until it comes to the other end when it reverses, letting the tool fall down.

The part A swings on the 3-inch bolt, the top arm being held in the tool-

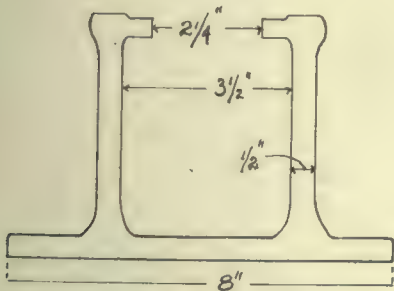

Fig. 2.—Section of Work Planed.

holder of the planer. Right and left nose tools are used for the work to machine underneath the left and right sides of the saw carriage.

HIGH SPEED PIPE TAPS

By F. E. Lauer.

The following article and sketch shows a favorite form of sectional pipe tap in detail and its efficiency as found by the writer. On account of the small diameter of the holder, only three blades are

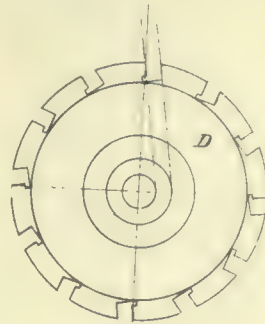

High-Speed Pipe Tap.

used and this will be found much better than four or more. It gives more strength and produces a rounder hole.

The body A is made from cast steel, as a machine steel cannot hold its rigidity in small section as this size tap with the heavy work that high speed steel puts it too. B shows the inserted blade made from 1/4" x 3/8" high speed steel 2 1/4" long. C shows the clamping or locating collar which is made from cast steel or case hardened machine steel. D shows the chuck which is used for chasing the blades, and the lay out so as to get a clearance on the blades. E shows the collar for clamping blades while they are being machined.

Four sets of blades are done at a time and when finished they have .010" ap-

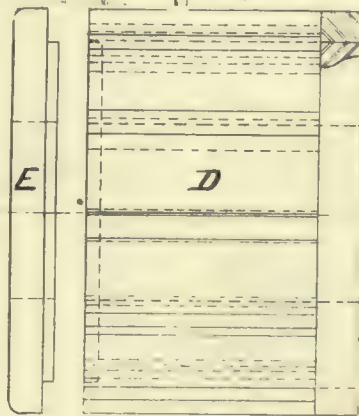

High-Speed Pipe Tap.

proximate clearance which produces a fine clear cutting tap for cast iron, while no doubt the same clearance would work efficient on steel. The tapping diameter of an 1" pipe tap is 1 3-16" approximate which give us a periphery of 3.75".

This tap is designed to run at 45 feet per minute which means that it travels 144 revolutions per minute. A fairly heavy lubricant is used on this work and

a tap can stand a ten hour run on cast iron fittings. A tap at this speed going into a fitting eight threads can make the complete cycle in six seconds, which shows the possibilities of high speed steel.

The machine that drives these taps is geared so as to feed the spindle the same pitch as the tap. It will be noticed that the cutting edge of the blades is placed

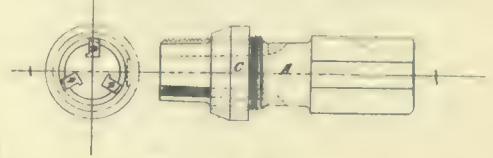

High-Speed Pipe Tap.

1-16" ahead of the centre line. This was done so as to give the tap holder a stronger section and also to reduce the clearance on the blades. If in this tap a blade breaks or gets worn, it is easily changed, the collar C is slackened off and the blade removed, the new one being immediately located by the threaded collar C, and if the end is in advance of the other blades it is ground off to suit. If it is back of the others the collar is again slackened and the blade brought forward sufficiently so as to allow itself to be ground in proper relation to the other blades.

If this tap is properly made it will be found a valuable addition to any first class shop. I would recommend the following number of blades for sectional pipe taps from 1" to 2".

- 1" pipe tap—3 blades—144 revolutions.
- 1 1/2" pipe tap—4 blades—115 revolutions
- 1 3/4" pipe tap—5 blades—100 revolutions
- 2" pipe tap—6 blades—72 revolutions.

This article is not a write up from theory, but is in every day use.

PIPE SHELF.

The shelf illustrated herewith is used to store things that accumulate in a small shop. The additions at the bottom are for bar iron or pipe. The shelf itself is suspended from the ceiling with 1/2-in. gas pipe, which is secured to the ceiling with floor flanges. The lower ends of the pipe extend through the board and the braces at the ends, which

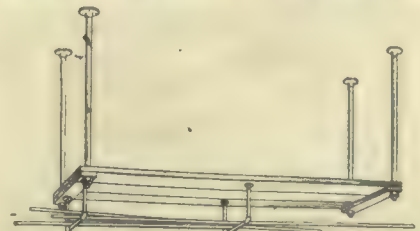

Shelf Suspended from Ceiling for Bar Iron, etc.

are secured with nuts. The shelf is 8 ft. long and 3 ft. wide.

The extensions on the under side of the shelf are made of 1/2-in. gas pipe, se-

eured to the shelf with floor flanges. L's are used to form the unions. The extensions are 4 ft. apart and are used to support small sizes of gas pipe and bar iron. The shelf is about 8 ft. from the floor and the extensions a foot lower.

WELDING CRANKSHAFTS.

In connection with oxy-acetylene welding at Charles Potter's, 85 Yonge St., Toronto, they use a jig for welding crankshafts which may be used to advantage in many machine departments.

The jig consists of a long base A on which are four top pieces B. These

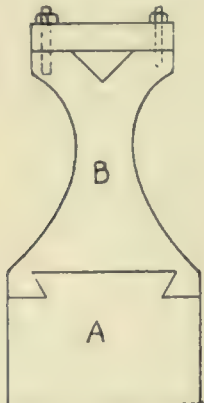

Jig for Holding Crankshaft.

may be arranged in any position on A suiting the length of the shaft. The shaft is securely fastened in the V-top. The block at the top is fastened by two screws. The crankshaft parts can then be easily set for welding the parts together. This jig has many other applications, for it may be used on a planer for crankshaft and other work.

ESCAPING THE ELEVATOR.

Perhaps the cheapest and most convenient device used for forewarning the lowering of an elevator is shown in the

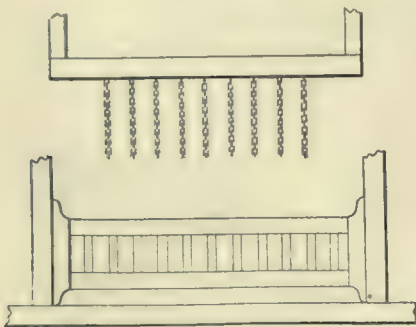

Escaping the Elevator.

engraving. A number of small chains, about two feet long, are hung from the bottom of the cage. If the elevator is coming down, and an attempt is made by the user to look up from the gate, when the elevator is within a short distance from his head, he will have time to avoid a serious, or perhaps fatal, ac-

cident, because of the warning given by the lowering chain. Of course, it will be understood that the height of the gate is often limited by the distance between the floors. This device is in daily use, in at least one factory, and doubtless if it were installed in many more, a large number of elevator accidents could be prevented.—Machinery.

BOLSTER PLATE.

By L. Bailey.

In constructing blanking and drawing dies it appears to be customary to use very heavy cast iron bolster plates, and in this way using a large quantity of iron and also a lot of room for storage of such dies. For this reason the writer has made a bolster that has proved a very satisfactory remedy for these evils.

The sketch herewith shows a bolster and also a blank-holder plate. This bolster holds dies 8-inch diam. and smaller, therefore it can be seen at once, that the cost of making dies will be greatly reduced by using a bolster that will dispense with a separate bolster for each die. The sketch is about quarter full size.

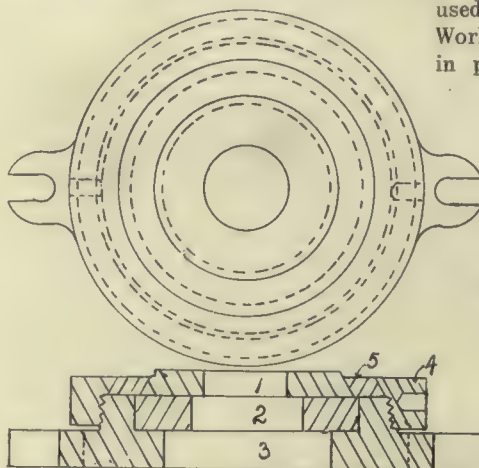

Bolster Plate

No. 3 is the base plate with a 10 pitch thread as shown. No. 4 is a ring to screw on No. 3. Smaller dies are held in place by the use of a reducing ring No. 5 and a reducing plate No. 2 as shown.

A drawing die with wide margin as shown at No. 6, it is held in place by a section ring No. 7 as shown at No. 8. When using a large die No. 6, lay die down, place No. 4 on top of die, put section ring No. 7 in as shown, then screw in base plate and the die is ready for use.

ATTENDANCE GRAPH.

At the Canadian Locomotive Works, Kingston, a graph is used to show the daily, weekly and monthly attendance

in the various shops. The accompanying illustration shows the method of carrying out the attendance graph.

The vertical line represents the number of employes and the horizontal line the days, each day being represented by

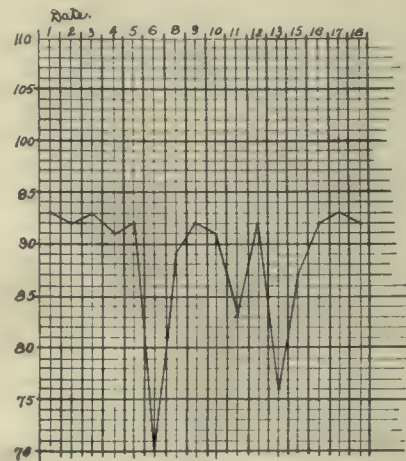

Attendance Graph.

two spaces. This may be varied, however, as desired taking one or more divisions for each day.

Section line paper, 10 to the inch is used at the Canadian Locomotive Works and is found convenient for use in plotting. The graph is applied to

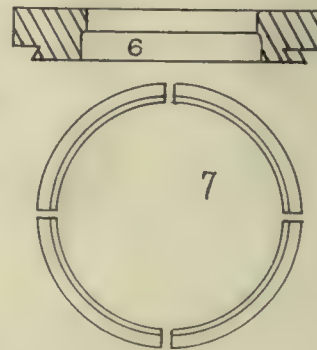

each shop, but may be enlarged to include the whole works. After the lines are plotted for each day, an average for the week may be plotted or for the month.

HANDLING LUMBER.

The accompanying illustration shows an economical method of handling large quantities of lumber. The Muskoka Wood Mfg. Co., Huntsville, Ont., have a switch of the G.T.R. running into their lumber yard, and are thus in a position to handle their lumber quickly, and in large quantities on trucks. In the view are shown quantities of lumber piled for drying. The advantages of inter-

Interesting Machine Work at John Bertram & Sons

Turning a Large Worm on a Lathe; Machining a Large Gear on a Slotter; Home-made Grinder and its Work; and Cutting Racks on a Shaper.

Some interesting methods are used in the works of John Bertram & Sons, Dundas, Ont., in connection with the manufacture of machine tools.

Fig. 1 shows a large worm being cut on a lathe. Holes are bored at the beginning and end of gear to allow the tool



Fig. 1.—Roughing Out Large Worm.

to start and for clearance at the end of the operation. Fig. 1 shows the worm before finishing and Fig. 2. shows the finished gear. In the foreground is shown the tool used, the nose being forged the angle of the finished worm.

Fig. 3 shows a large Bertram slotter on which is being cut a large gear. The roughing and finishing tools are shown

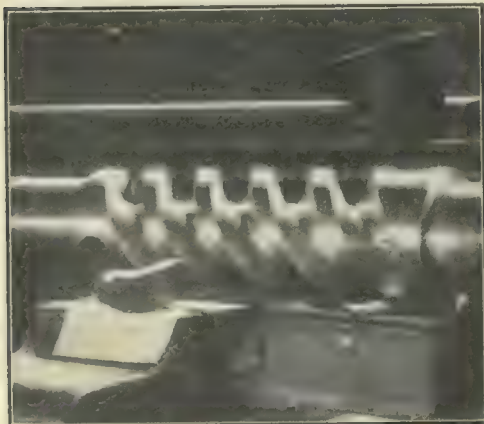

Fig. 2.—Finished Worm and Lathe Tool.

on the slide of the machine. The former tool has stepped edges while the latter has been given a better cutting edge by being hollow ground on top.

In the lower right hand of Fig. 3 is shown the feed mechanism which moves the work forward toward the tool. There is a device which automatically prevents the tooth being cut too deep. The wheel A is a visible indicator and is convenient for setting the machine.

It shows the operator the position of the feed at a distance.

Next to wheel A is a pinion which meshes into the gear B. B has an annular T-slot as shown carrying the stud C. When this is set properly, it strikes the arm D which controls the shield E and automatically moves E to cover the notches in the feed wheel F, all further movement of the feed screw being thus prevented.

The arrangement of the tool blocks in the ram is shown in Fig. 4. This ensures its being held rigidly in position during the cutting stroke. Tool block A is pivoted at P and at the upper end has an extension surrounding the cam D. Fixed on the side of ram support is the rack B, and in this, the gear C, mounted on a stud in the ram itself, gives motion to a gear which drives the cam shaft D by friction washers, so that it can slip, after the cam D has been forced into place.

When the ram starts downward, gear C revolves in the direction of the arrow and drives the gear on D in the opposite direction, throwing the point of the cam against the hardened incline block E, which forces the upper end of the tool

thus relieving the tool on the return stroke. The desired clamping effect is secured by adjusting with a screw the block E.

Figs. 5 and 6 show a home made grinder in use in the Bertram shops. It is very serviceable, the board at the

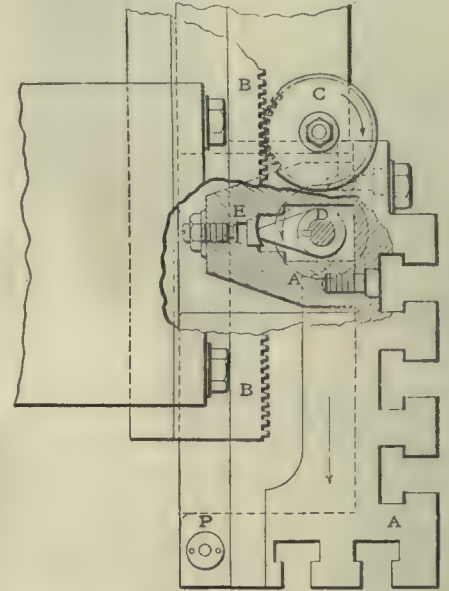

Fig. 4.—Tool Lifting Apron of Slotter.

back giving an idea of the wide range of work that may be accomplished on it. Fig. 5 shows the machine at work on a rack-cutting tool. A rack-cutting tool is shown also at the left of the grinding

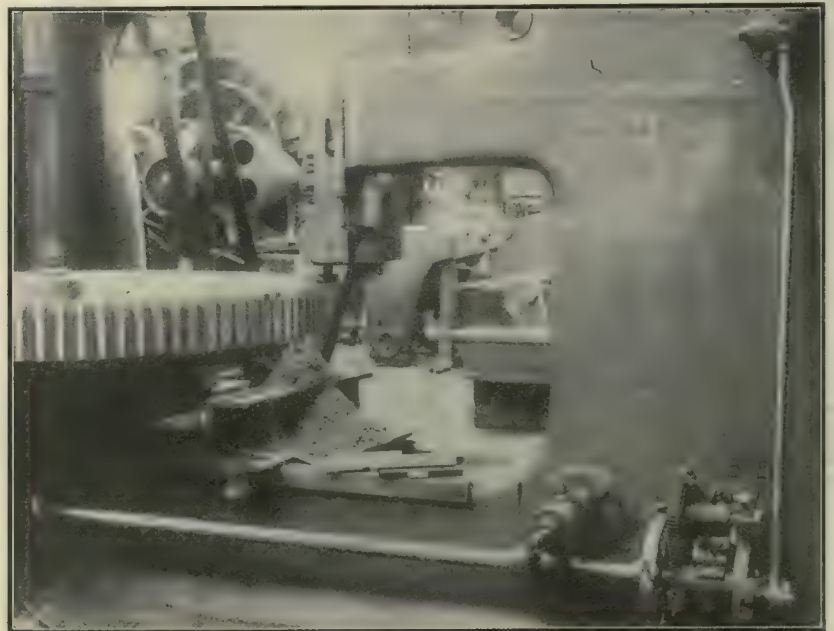

Fig. 3.—Cutting Large Gear on Slotter, John Bertram & Sons.

block solidly against the ram and ensures the cutting tool being held in proper position during the cutting operation. When the ram starts on the return stroke, the cam D is thrown up, allowing the upper end of the tool block to be forced out by a powerful stroke

wheel and gives an idea of how it is ground. Fig. 6 shows it grinding a small cutter. The machine is conveniently operated, has lever feed and easily adjustable stops.

Fig. 7 shows a method of cutting racks on a shaper with a traversing head. A

second table is utilized for holding the racks to be cut, and a large index wheel placed on the traversing screw ensures accurate spacing.

The tool holder and tool are interesting. The tool holder replaces the ordinary clapper back and swings from the same point, being lifted out of the work and held during the return stroke by the



Fig. 5.—Home-made Grinder Grinding Rack Cutter.

spring at the top. The tool is held rigid during the cut by using the cam A, operated by the arm B through the lever C, which is controlled by the two collars striking the stationary support at the end of stroke. Thus the cam is automatically forced against the upper end of the tool holder, supporting it rigidly during the cut and is automatically withdrawn just before the return stroke. The tool is fed down to a positive stop.

Figs. 7 and 8 show the tool which is of multiple design. Each tooth is relieved, each tooth taking a chip similar to the broching machine. A rake is ground on the cutting-edge of each tooth



Fig. 7.—Cutting Racks on a Shaper. John Bertram & Sons.

and this is alternated to equalize the side thrust when these are in the cut and the result is a good cutting action.

A STEPPING STONE TO SUCCESS.

By Tom L. Johnston.

There are plenty of good mechanics who are plugging away in small shops for low wages, who could hold good

jobs in large shops at good wages, but they do not know what is going on outside of their own little sphere. There are technical journals pertaining to almost every trade, and if these mechanics would take them and study them they would keep abreast of the times and get out of the rut they are liable to be in all their lives. Some of them turn out good work, considering the material they have to work with, but it is always the same old style, and if they were put in a first-class shop with every labor-saving device at hand they would not know where they were at.

I know of one young printer who was working in small shops for nine and ten dollars a week, but who was wide-awake and studied every journal relating to his trade he could get his hands on, and is now holding a permanent position at twenty-five dollars a week.

There is more to be learned from a trade journal than one thinks, until they begin to take an interest in it and then they would not be without it.

I once heard a grocer say he would feel like a preacher without a Bible if he did not get his trade journal, so it is quite evident a man in any line of work can profit by taking some journal devoted to his trade.

NEW PATENT WIRE LATHING.

The B. Greening Wire Co., Hamilton, have just secured a patent on a new trussed hard steel wire lathing, in which are contained the best features of the general products of this class. It is

the truss formation of the lathing, it may be stapled or nailed directly along the studs, joists or sheathing without

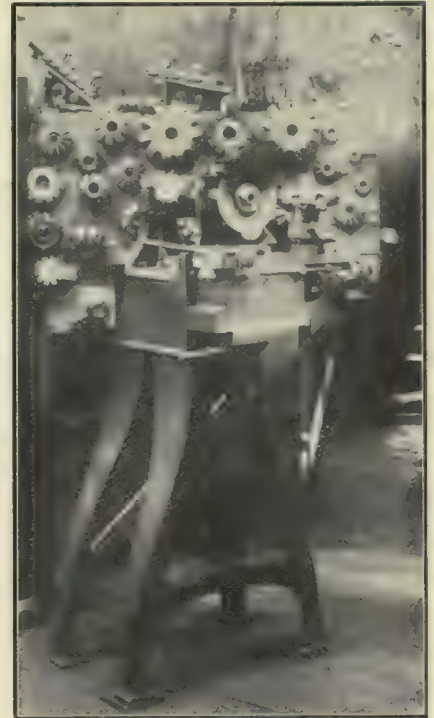

Fig. 6.—Grinding Small Cutter and Other Cutters Machined on Grinder.

any furring—a feature of great importance—and the absence of the lapping, lacing and the furring largely ensures the lowest possible cost in erecting. It has been successfully applied to 16-inch centres, and the saving thus effected is an important factor in the cost of build-

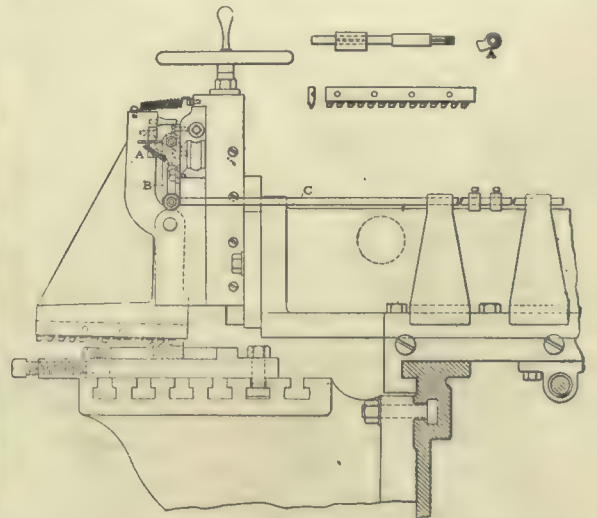

Fig. 8.—Rack Cutting Device of Shaper.

supplied in continuous lengths up to 100 yards, with a selvage on each side and in widths to suit the spacing of the studs or joists. There are many special points of interest in connection with this lathing. The selvages are stapled or nailed along the studs or joists, consequently there is no lacing. Owing to

ing, but even 18-inch or 20-inch centres could be used by substituting a heavier grade at a slight advance in price.

H. P. Hoag for the past two years superintendent of Fairbanks-Morse Mfg. Co., Toronto, has accepted a similar position with the Gould, Shapley & Muir Co., Brantford,

Several Jigs and Tools Used in Railroad Shop Work

In Repairing Locomotives Quickness and Accuracy are Assisted by Designing Jigs and Tools to Facilitate Work—Several are here Illustrated.

By GORDON C. KEITH

On several occasions reference has been made to the G.T.R. shops at Stratford. They contain many interesting methods, machines and systems which are above the ordinary. In locomotive work it is the aim of the companies to

works in the socket, the general design being shown in the illustration. No sizes are here given as dimensions can be made to suit the work to be done.

The steel pins are hardened steel. The drill takes a standard Morse taper drill.

iron block and the wedge is then driven in place.

The tool is here 3-16" wide but any width tool may be used depending on the work to be done. The tool is 13 1/2" long with a standard taper top.

Chuck Extension.

On a boring mill it is often desired to bore work which cannot be chucked on

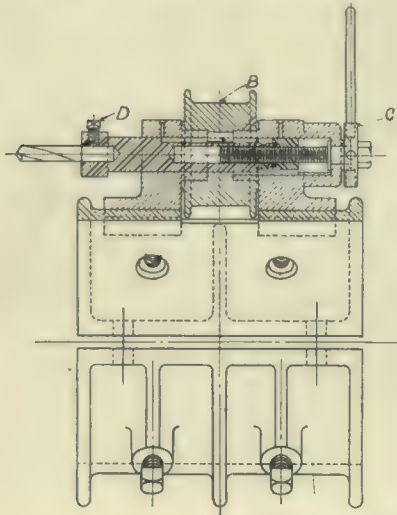

Fig. 1.—Arrangement of Hub Liner Drilling Machine.

keep the locomotives on the road and in the repair shop as little as possible. With this in view many jigs, tools and devices have been evolved to facilitate the work and hurry the repairs with a speed consistent with good workmanship so that the locomotive will not have to again enter the shop for repairs for some time.

Jigs and tools made specially for the work are therefore as indispensable a factor in doing the work economically as in manufacturing establishments. Some of the jigs, at least, described in this article are original, being designed in the Stratford shops.

Hub Liner Drill.

Fig. 1 shows the arrangement of a hub liner drilling machine. This drills the liner and axle box without removing the box from the shaft. Provision is made for clamping the machine over the axle, the two parts being fastened in position by two bolts on either side of the drilling machine.

Adjustment is made by eight screws A shown in the illustration. The power is delivered from an overhead shaft by a belt, to pulley B. The drill is fed by the ratchet C. A small screw D holds the drill in place; the drill being easily replaced by a reamer for finishing if necessary. There are two of these machines so that the liners on both boxes may be drilled at the same time.

Ball Joint Floating Reamer.

A toggle joint for reaming holes on a drill is shown in Fig. 2. A 2 1/2 inch ball

One side is flattened to hold reamer and keep it from turning.

Multiple Tool.

A multiple tool is shown in Fig. 3. A is the distance between tools, which may be varied by a movable block. In

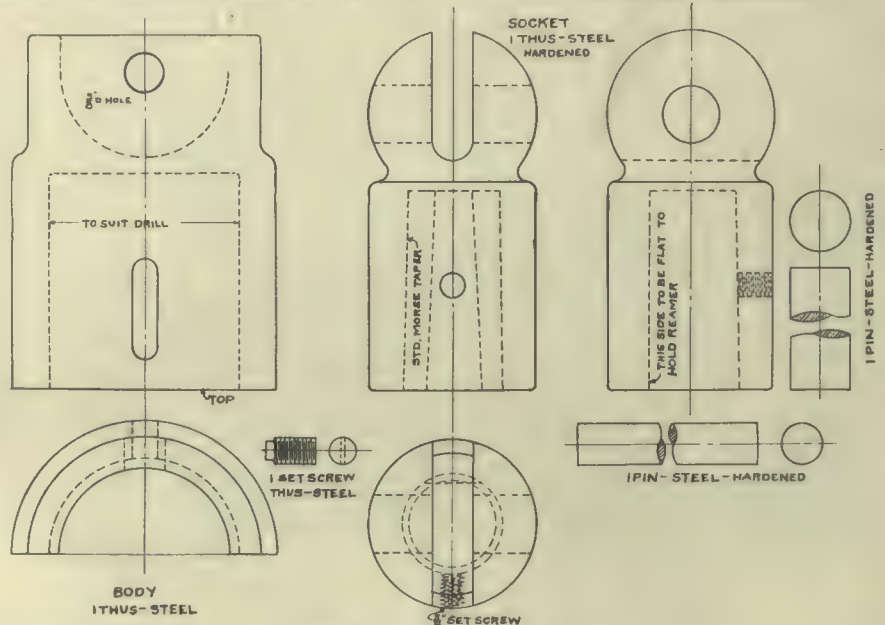

Fig. 2.—Ball Joint Floating Reamer.

the illustration they are 1/2" apart but by inserting inch blocks the tools are then kept one inch apart.

The tools are held in place by the tapered wedge B. After the last tool is put in place, the distance between the tool and hole is made up by inserting an

the face plate of the boring mill. This can be done by using four castings similar to Fig. 4. These slip over the jaws on the boring mill and the larger work can then be easily gripped for boring.

Fig. 5 shows the body casting and gears of an angle drill and Fig. 6 shows

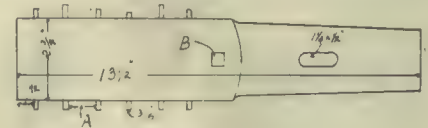

Fig. 3.—Multiple Tool.

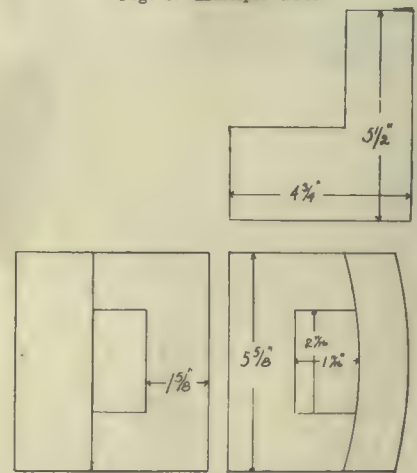

Fig. 4.—Chuck Extension.

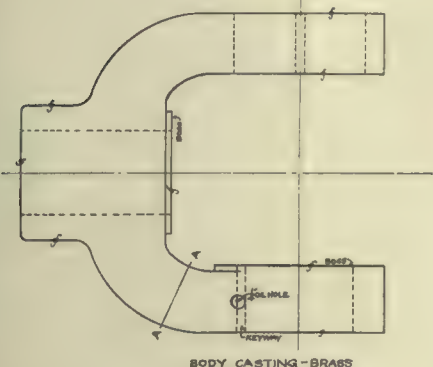
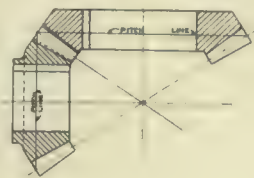
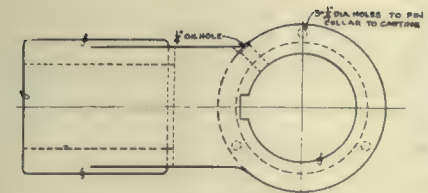

Fig. 5.—Right Angle Drilling Attachment.

the details of the angle drill. For right angle drilling, the feed is from the top of the drill, the drill spindle moving freely independent of the drive.

The large gear has a pitch circle diameter of 4.3125", number of teeth 27, diametral pitch .1597 and depth 11-32" full. The pinion has a pitch circle diameter of 2.875", number of teeth 18, diametral pitch .1597 and depth of teeth 11-32" full.

Turning Axle Box Brasses.

In the jig shown in Fig. 7 for turning axle box brasses, the brasses are placed

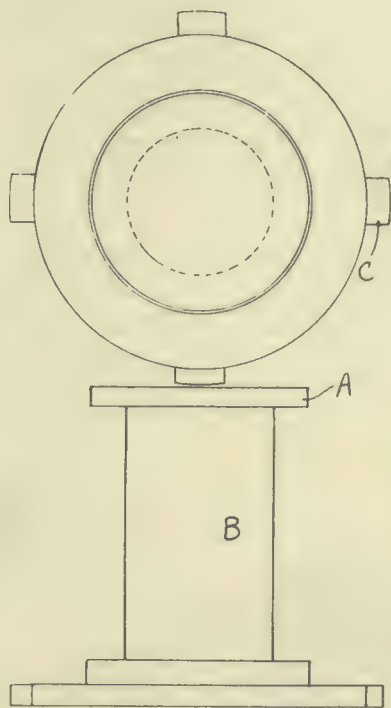

Fig. 7.—Jig for Turning Brasses.

against the metal post B which is 12½" high x 7" diam. The distance between the brass and cap A is filled in with blocks and the cap A is screwed down and fastened by three bolts. The cap is 10½" diam. The jig is fastened to the face plate of the boring mill on which the work is done, by the clamps C.

A lathe tool shown in Fig. 8 is used to turn the brass. As may be seen from the illustration the tool holder may be used on other work, it being clamped in place by two screws. The tool may be

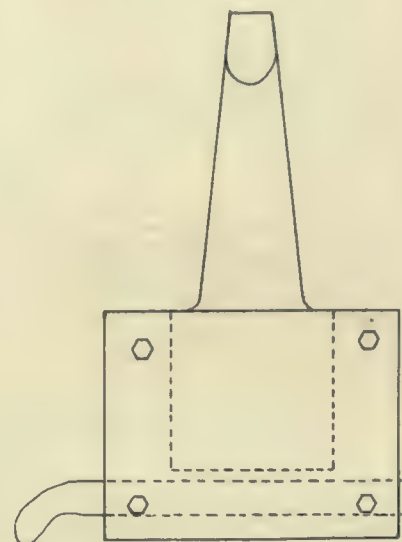
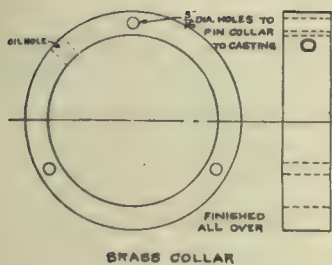
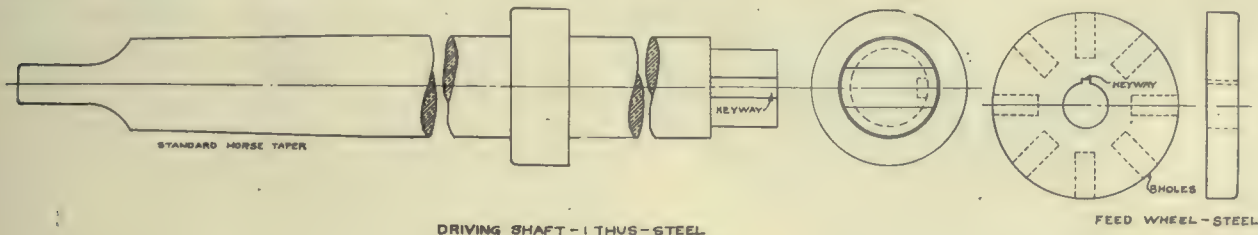
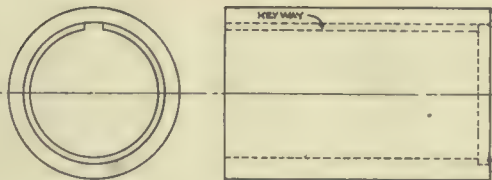

Fig. 8.—Tool for Turning Brasses.



BRASS COLLAR



LARGE BUSH - 1 THUS - STEEL

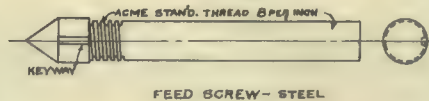

FEED SCREW - STEEL

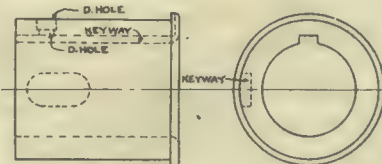

END BEARING - STEEL

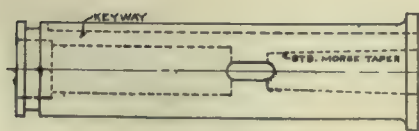

SPINDLE - STEEL

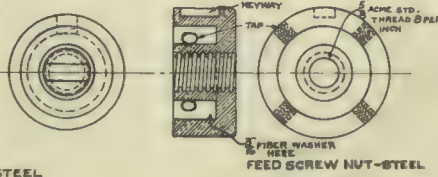

FEED SCREW NUT - STEEL

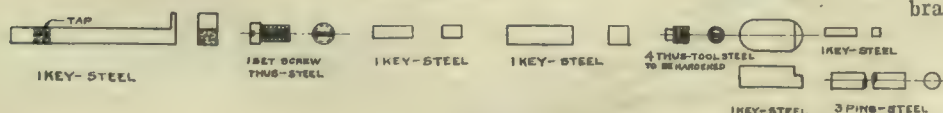

Fig. 6.—Details of Angle Drilling Machine.

clamped in any position to suit the work to be done.

The outside of the brass is finished on this jig. The inside is bored after the brass is pressed into the axle box.

DEVELOPMENTS IN MACHINERY

New Machinery for Machine Shop, Foundry, Pattern Shop, Planing Mill; New Engines, Boilers, Electrical Machinery, Transmission Devices.

NEW SAFTY CUTTER HEAD.

Any improvement in a machine which will increase the safety of the operator is surely of value, providing, of course, that the efficiency of the machine is not lessened by the change. In a wood-working shop, the hand planer is probably the most dangerous of any machine tool, and the statement has been made that more fingers have been lost in hand planers than by any other single type of tool.

A new cutter head for hand planers and joiners, which assures maximum safety to the operator by reason of its permitting the tables to be set very close together, has lately been introduced in the woodworking machine

shaped head and thus permit the tables to be set very close to the cutter.

The illustration herewith shows this new circular cutter-head in the manufacturer's No. 61 C hand planer and joiner with the tables drawn back, giving the reader an idea of its construction.

BRYANT CHUCKING GRINDER.

Recently, there was placed on the market a grinder which accomplishes all the operations on work by grinding wheels instead of cutting tools. To this new type have been applied the principle underlying the design of the turret lathe with its semi-automatic features. Work is finished from the rough or from sur-

er wheels for internal work, being designed to enter a $\frac{3}{4}$ -in. hole if desired. It may also be employed for buffing and for outside grinding. A rigid fixture, clamped to the back of the machine, holds the wheel in front of the central spindle. The wheel is swung into and out of working position without interfering with the use of other wheels.

The three grinding spindles are carried in the head carriage. The turret feature is absent. The spindles are adjustable lengthwise, in heavy sleeves, for position, and are locked rigidly while operating. The wheel feed is with the carriage slide only; that is to say, longitudinal. The cross feed is in the head, carrying the work, which is held either in a chuck or spring arbor, on a massive spindle. In other words, the stroke is in the wheel carriage, the feed in the work carrier. A variable speed mechanism actuates the traverse movement of the wheel carriage. The feeding mechanism of the work carriage permits of a wide range of feeds; automatically releases the feed at the desired point, and also provides for automatically reducing the amount of feed as the work approaches completion, the point of release and the degree of reduction being determined by cam forms. A gear box gives nine changes of speed for the work spindle. Both traverse of the wheel spindle head and feed of the work carriage are arranged to reverse.

The machine is driven from one constant speed pulley, which greatly simplifies the overhead works. This drive is transmitted to the wheel spindles by two belts only, and the arrangement is such that only one spindle is revolving at a time, or all are idle. The wheels are so grouped with reference to the work that each holds a natural position for the operation it is intended to perform, which reduces to a minimum the amount of adjusting in changing from one operation to another.

The operation of each grinding wheel is independent of the others, not only in that it revolves alone, but in its individual lever for adjustment to the work and in its knock off and reversing dog in the carriage. In the work carriage there is a cam and stop pin to govern the feed for each spindle. In fact, the control is equal to that of modern turret lathe practice, in securing facility and accuracy in the manufacture of duplicate parts. An auxiliary or length

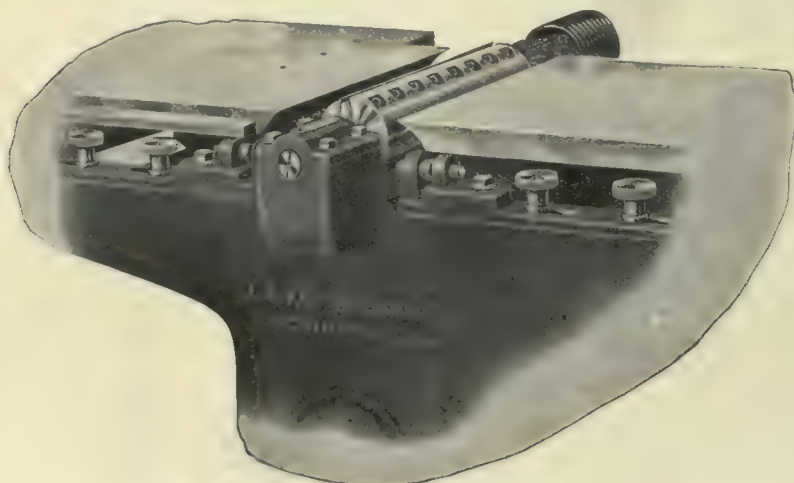

Fay & Egan's New Safety Circular Cutter-Head.

tools manufactured by the J. A. Fay & Egan Co., 362-382 W. Front St., Cincinnati, Ohio. In the old style cutter head with the square block and knives bolted to its sides; the square shape of the block would neither permit the tables to be set close together nor did the head itself fill the opening between the tables. Thus with the slightest slip on the part of the operator his fingers might be drawn in between the tables and badly mutilated if not lost.

The new safety circular cutter head closely fills the opening between the tables so that the most severe accident that could possibly happen would be the scraping of a finger or thumb. The design is such that the cutting edges of the knives protrude but slightly from the circumference of the cylindrical-

faces previously obtained in turret lathes and afterwards hardened. The machine shown in Fig. 1 will grind either outside or inside diameters, together with the faces of both internal and external shoulders. Its scope includes cylindrical and conical shapes and it has a capacity of 12-in.d.x12-in. long.

There are three grinding spindles. The standard equipment comprises 10-in. wheels on the front spindle for outside work; 6-in. wheels on the rear spindle for either outside or inside work or face grinding, and $2\frac{1}{2}$ -in. wheels on the middle spindle for internal grinding. These sizes may be varied to meet requirements, but the design regularly furnished gives to each spindle the speed required for the diameters of the wheel as stated. An auxiliary fourth spindle, not shown, is furnished as a fixture to carry still small-

slide for the work carriage assists in the convenience of manipulation.

The whole machine is a complete new design, but probably the reader will be more interested in the work the machine will accomplish. Fig. 2 shows a cast iron gear with a conical clutch surface. This has to be ground, as shown, in the bore, the clutch surface, and on one face and outside diameter. In the first operation the work is held by tooth-shaped jaws which hold it concentric with the

position (which finishes this piece) the work is held by its finished clutch surface on a taper arbor mounted in the work spindle. This arbor may be ground in place to insure absolute accuracy.

Fig. 3 shows the grinding of a tempered collet, which is done at one operation, although four grinding-wheel positions are necessary. The first of these shows the collar held on a taper draw chuck and the internal-grinding wheel at work sizing out the nose. In the second

around the substantial vertical shaft at the end of the body proper, so that the rigidity of the machine is in nowise affected.

A rather complicated piece of grinding is shown in Fig. 4, in the shape of a special hardened gear with a taper bearing. This is chucked in special tooth-shaped jaws, and the first wheel position shows the back spindle at work. In the second position the small internal wheel is doing external grinding on the

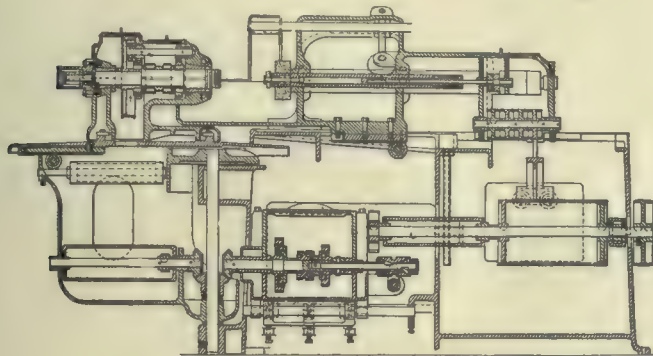

Fig. 1.—Section Bryant Chucking Grinder.

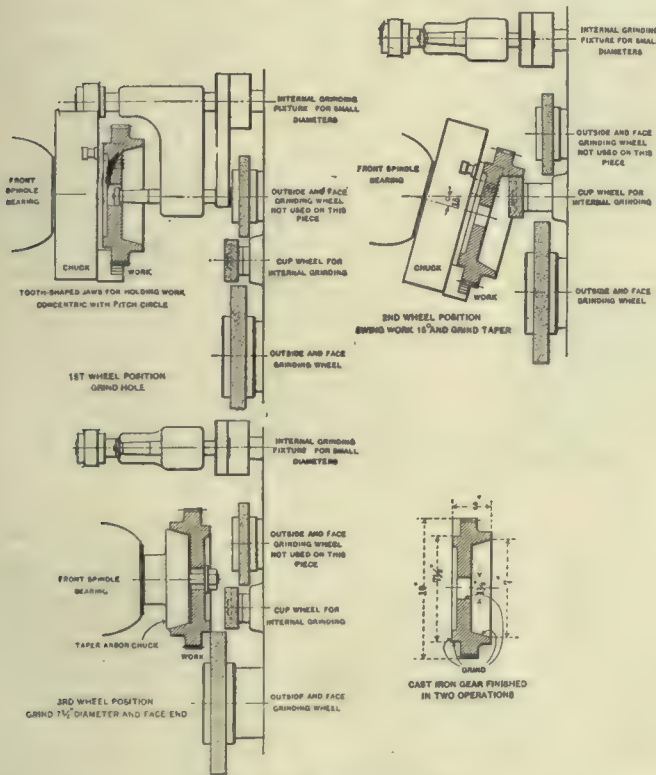

Fig. 2.—Grinding Cast Iron Gear.

pitch line. Here the bore is ground with a supplementary internal attachment, as shown, provided for work having small holes. (This supplementary spindle may also be used for buffing and polishing with rouge and a soft wheel.) In the second wheel position the work spindle and the bracket on which it is mounted are swiveled to the angle of the conical surface 15 degrees, as shown, which is finished with the regular internal wheel. For the second operation and third wheel

position the front face is being ground by the large outside wheel and also being buffed by the wheel on the rear spindle.

In the third position, the large wheel is grinding the outside and the back face, while in the fourth position the work spindle has been swung to the necessary angle, 15 degrees, and the outside wheel is grinding the tapered front seat. It will be noticed that the whole work head is swung for angular work

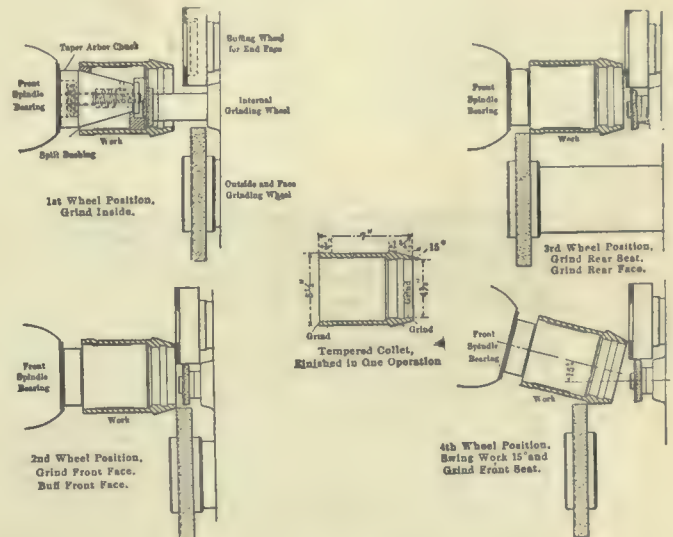

Fig. 3.—Grinding a Tempered Collet.

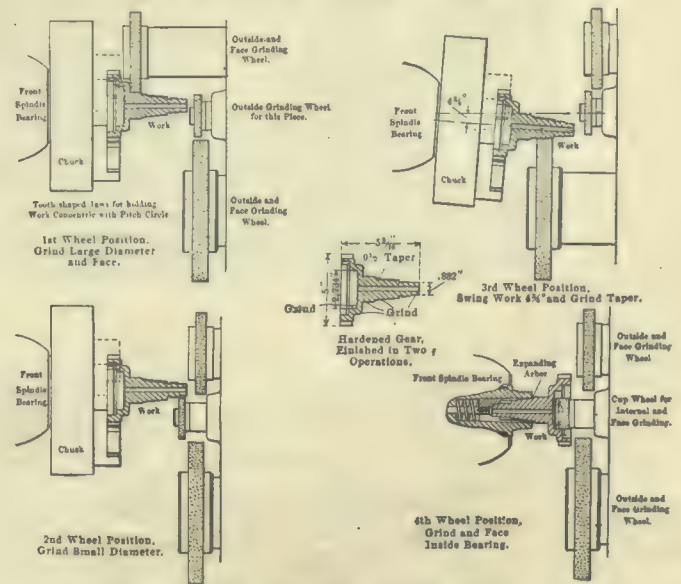

Fig. 4.—Grinding Hardened Gear.

small diameter, while in the third position the work has been swung so that the wheel on the front spindle is finishing the taper portion. It is then necessary to reverse the piece and a small cut wheel on the internal spindle is at work inside the gear.

The machine is the design of W. L. Bryant, and is being placed on the market by the Bryant Chucking Grinder Co., Springfield, Vt.

BENN CLUTCH.

The Benn clutch which is being placed on the Canadian market contains several interesting features. The driving piece N keyed to the shaft is provided with arms and driving pins (not shown in illustration) which carry the friction rings R R round, while allowing them longitudinal movement parallel to the shaft. The toggles E E move the friction rings into or out of contact with the shell G D, and are themselves brought into their most advantageous position (nearly straight) for transmitting pressure by the forward movement of sleeve H with its levers A A and links B B.

The requisite friction for driving is obtained by the tension of the spiral springs joining the long ends of levers

the clutch shell. If it has to be out of gear for long periods the pulley and clutch shell should be carried on a sleeve clear of the shaft, and supported by independent bearings, so that friction and wear on the shaft is avoided.

These clutches are manufactured by the Unbreakable Pulley & Mill Gearing Co., London, and are being placed on the Canadian market by Vandeleur & Nichols, Dineen Building, Toronto.

ONE ROAD TO THE TOP.

It is one of the paradoxes of life that the fellow who does his work faithfully without being watched by the boss, comes to be the very person whom the boss most watches.

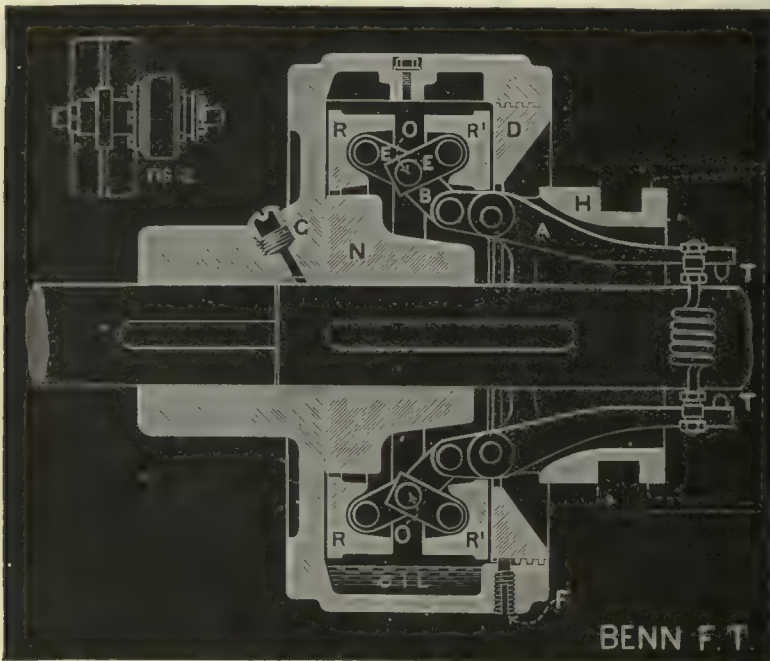

The Benn Clutch, Shown Out of Gear.

A A, which springs open slightly as the links B approach the vertical, and when they pass the vertical, lock them and the toggles and friction rings in gear. Adjustment for toggle position and for wear of parts is obtained by screw ring D, the exact position of the toggles and internal rings being ascertainable at any time from the outside by the clearance between shaft and pointers T T.

As shown in the illustration, a good bearing must be provided close up on each side, and the two shafts must be lineable. If these two conditions are given, the clutch is guaranteed.

When used to carry rope or belt pulley, the clutch is arranged as in Fig. 2 shown at the left of the large illustration. The pulley, which is bushed with gun-metal and provided with spring lubricator for solid oil, is bolted on to

But this sort of worker is watched not to make sure of his fealty but to determine the extreme of his capabilities so that the institution of which he is a part may take advantage of unusual fidelity by putting its exponent into the place where that faithfulness may be of greatest value.

The man or woman, the boy or girl, who will work without being watched, is so unusual that the appearance of one in any business institution is almost startling.

At the start, the reports of his immediate superior testifying to so amazing a phenomenon are received by those higher up with unconcealed incredulity.

"It will wear off," they say, for in their experience it nearly always has worn off.

"He's a new man and uncertain of his job," say others, "but pretty soon he

will fall into the rut and do as all the others do."

But if he doesn't; if on the other hand he works on just the same when the boss is elsewhere as when he is watching, the conviction slowly steals over those in authority that they have accidentally picked a winner.

From then on the worker is watched. He is tested. His faithfulness being a certainty, the question of his intelligence and capacity must be determined.

Around him are doubtless others more quick-witted, more brilliant. Judged by their capabilities these others may be one hundred per cent. men, though only fifty per cent. men in performance.

But the men who are wise enough to be in charge of the larger affairs of business know that a faithful man who is always on the job achieves more and is of more value than the apparent one hundred per cent. man whose person or whose brain is away at the baseball game.

Thus little by little more important tasks are assigned to the faithful employe. Though he may be the latest comer he is the soonest promoted.

And the others—well, they sit back and berate the boss. They always knew that the faithful one had a pull or that the boss has it in for them.

They cannot see and they cannot understand the simple reason why the man who works when the boss isn't looking, gets ahead. If they could see or understand some of them would follow the faithful one's example.

And some of the others will tell the faithful one that he is "trying to get a stand in" with the boss. To their infantile minds it seems the highest stretch of foolishness to try and stand in with the men who determine your wages and your tenure.

But the faithful one if he has sense as well as honesty will not swerve. As long as he sticks to the fundamental honesty of giving a full day's service for a full day's pay even if there be a chance to soldier and renege, he travels the road that leads to the top and no man can stop him.—Silent Partner.

The standardization of parts reduces the number of jigs and tackle used in manufacture, and increases the production by expertness due to frequency of handling. Thus the cost per piece is lessened, and the possibilities of quicker deliveries give a more rapid turnover of capital. Not the least point in the favor of standardization is the influence of such activity on the men in the shop. During slack periods standard parts may with advantage be built for stock, and thus help to meet the call of urgent orders.—Mechanical World.

Oxy-Acetylene Welding Makes the Scrap Pile Less

Some Castings That can be Economically Repaired, Thus Saving them from the Scrap Pile.—A Description of the Linde System.

A Linde Oxy-Acetylene installation has been made at Charles Potter's, 85 Yonge St., Toronto, where repairs are being made to gas engines, patterns, etc., showing the great saving that may be made by using Oxy-Acetylene system of welding. The installation was made by the Linde Air Products Co., Buffalo, N.Y. The Canadian company is in Montreal.

Complete systems are designed and installed, the one at Charles Potter's including a full range of pipes, from No. 1 to No. 15. A portable attachment allows the torches to be used on any work that cannot be brought into the shop. As an illustration of what may be done, the frame of a Ford car was broken, the welding apparatus was taken to the

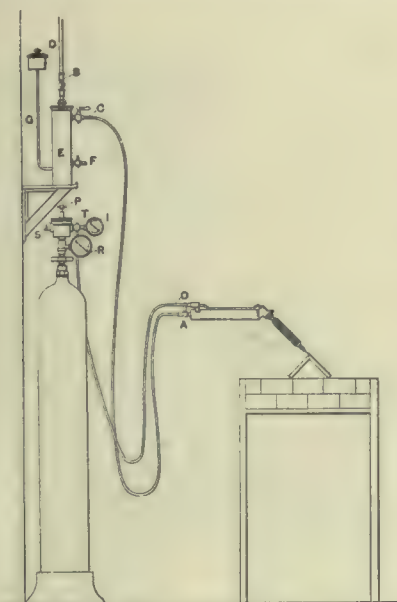

Fig. 1.—Linde Oxy-Acetylene Welding Outfit.

car and the frame repaired without dismantling the car.

The Oxy-Acetylene blowpipe (Fouche's patent), is a low pressure blowpipe, constructed on the injector principle and is designed and proportioned to meet all the special conditions with which an Oxy-Acetylene blowpipe must comply. It is so constructed that the flame cannot strike back. The gases are well mixed in the injector chamber before they issue from the nozzle of the blowpipe and the nozzle itself is so constructed that the possibility of carbonaceous deposit in the orifice is practically obviated. It is made in ten sizes.

Fig. 1 represents diagrammatically a complete Linde Oxy-Acetylene blowpipe installation with the exception of the acetylene generator and holder which

may be placed in any suitable position and at any convenient distance from the blowpipe apparatus.

In the Fig. 1, B is a cock connecting the inlet nipple of the hydraulic back-pressure valve with the acetylene supply pipe from the acetylene holder. The blowpipe is connected at A by means of an ordinary stout rubber tube with the outlet cock C of the hydraulic back-

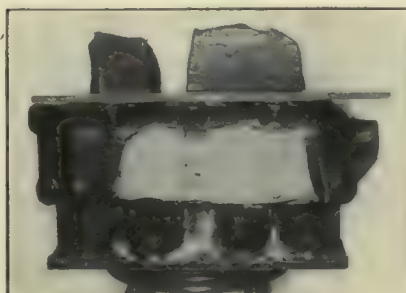

Fig. 2.—Broken Taxi-Cab Cylinder.

pressure valve which forms the acetylene supply pipe of the blowpipe.

The blowpipe is connected at O by means of a stout rubber tube with the outlet cock T of the oxygen pressure regulator, which is attached, as shown, to the valve on the oxygen cylinder. This pipe conveys the oxygen supply to the blowpipe, and should be securely attached, as it is subject to pressures varying from 10 pounds to 30 pounds per square inch.

Repairing Castings.

Fig 2 shows a broken cylinder of a 4-cylinder Toronto taxi-cab which was repaired at Charles Potter's. The repaired

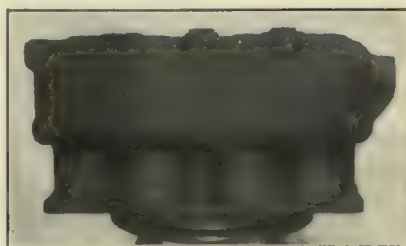

Fig. 3.—Repaired Cylinder.

cylinders are shown in Fig. 3. The water jacket was broken out, the broken pieces resting on the top of Fig. 2. The cylinder was pre-heated so that no strains would be set up afterwards.

Tool holders, patterns, etc., from \$3 up can usually be repaired economically. Other things that can be repaired are printing presses, crankshafts, automobile parts, pulleys, gears, valves, etc. The repair is made at a much less cost

than making a new part. The repair seldom costs over one-third of the first cost of the casting and usually much less. On small castings the percentage is much larger than on larger ones. On small repairs to large cylinders, automobile frames, etc, the percentage is very low.

UNIQUE CAR BARN HEATING SYSTEM.

The new system of heating installed in the car barn of the Toronto and York Radial Railway, at St. Clair Ave., Toronto, Canada, is unique. In place of a steam boiler, which in ordinary car barns provides steam for heating, but seldom for power, there will be a heater for transferring the heat in the coal direct to the air, and a fan will force this heated air through the distributing system. The heater, which resembles a sectional water-tube boiler, is called an "air-tube" heater. It is the unique feature of this system which is being installed by the Harrison Engineering Co., of New York City. This new method of heating will be watched with interest, for there are no steam pipes or coils to be drained, no boiler to burst, and no accessories to be emptied or blown down in order to prevent freezing, should it be necessary to shut down the plant during the winter.

CENTRAL RAILWAY CLUB.

The regular meeting of the Central Railway and Engineering Club was held in the Prince George Hotel, Toronto, on Feb. 15 when a paper was read on "The Principle of Melting Iron in the Cupola," by E. B. Gilmour, superintendent of the molding department at the Canada Foundry, Toronto. This paper is reproduced in the Foundry Department of Canadian Machinery. M. J. Duguid, president, occupied the chair. Many members took part in the discussion of the paper.

A social evening was tendered to members and prospective members at the St. Charles Hotel on Feb. 25.

A. F. Well, B.A.Sc., and J. V. Gray, formerly of the Bishop Construction Co., are carrying on a general engineering and contracting business under the name "Wells & Gray, Ltd.," at 315 Confederation Life Building, Toronto.

George Y. Chown, B.A., has resigned his position as Registrar of Queen's University and secretary of the School of Mining to devote his time to managing the affairs of the Wormwith Piano Works, of which he is now sole owner. Mr. Chown will retain the position of treasurer of Queen's.

Equipping Each Machine With Its Own Power Plant

How Manufacturers have Applied Electric Motors to Drive Machinery—Some Interesting Installations of Individual Motor Drive

Illustrated herewith are a number of machines equipped with motor drive. Fig. 1 shows a Toledo open-back, inclinable, plain press for making handles,



Fig. 1.—Motor Driven Press.

lock parts and sheet metal work made by the Toledo Machine Co., Toledo, Ohio. It has its own power plant. In other words it is motor driven. The motor is $2\frac{3}{4}$ h.p., 250 volt Westinghouse, type "S" direct current shunt motor which runs 1025 r.p.m. Line switch and starting rheostat are shown mounted directly on the machine frame. The large spur-gear reduction, meshing with

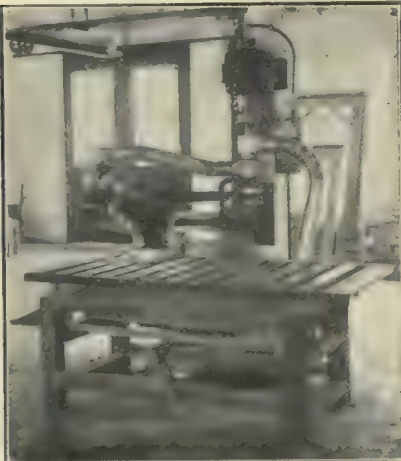

Fig. 3.—Motor Connected to Vertical Shaft.

the motor pinion, transmits directly to the crank shaft which carries the pitman connecting to the cross-head punch motion.

Advantages.

One of the advantages of motor drive is in getting power around corners.

When certain machines are in use, it is not necessary to run the whole line shafting. That is a second advantage. Any machine that is idle a great part of the day should be driven by individual motor. When a number of machines are to run practically all the time it is often economical to run them all by one motor.

Another advantage in motor drive is the placing of the motors. It may be located on the floor, on the ceiling or on the machine depending on the work to be done.

Fig. 2 shows a motor mounted on a platform suspended from the ceiling direct connected to a blower. The motor is a Westinghouse 30 h.p. squirrel cage 60 cycle, three phase, 220 volts.



Fig. 2. Motor Arranged to Drive Blower.

The blower is a 30 inch, collecting the shavings from the other machinery and forcing it across a roadway.

Fig. 3 shows a Westinghouse motor connected to a vertical shaft driving a post sander. The motor is a 2 h.p. 220 volts, started from a three pole, double throw switch, wired without fuses for starting but with fuses on the running side.

On the starting box in Fig. 2 is printed the words "Stop Motor." This is a constant suggestion to the operator that the realization of the advantage of intermittent operation are up to him.

WESTINGHOUSE 1910 DIARY.

The Westinghouse Diary for 1910 has some additions over those issued during the past six years. It contains much condensed material of instructive type and pertaining mainly to electrical questions. Not the least interesting of the contents is the brief but impressive presentation of Westinghouse plants. Among the reminders of an especially ingenious character are the wrinkles introduced with the wire table. A wire which is three sizes larger is shown to be twice the weight, twice the area, but only half the resistance. Of course, this ratio applies to the other sizes. One thousand feet of No. 5 wire weighs 100 pounds and No. 10 wire is almost exactly 0.10 inch diameter. These and many other pointers of more or less consequence to those using or contemplating the purchase of electrical apparatus are given space in this neat leather-covered handbook of information.

OIL FOR WINTER USE.

It is often difficult to keep machinery properly oiled in cold weather, as the oil freezes in the oil holes and the cups, and the oil upon the ways of the lathe and planer becomes stiff, causing the machines to work hard. A good oil for winter use is made by mixing graphite with cylinder oil until in a thick or pasty consistency, and then adding kerosene until it flows freely. This oil will not become stiff at 14 degrees below zero, and is valuable to those operating machinery outside or in cold shops.

Correspondence

One of the suggestions given in reply to our editorial in the February issue asking for comments, was that a question and answer department be established. This will appear under the heading of correspondence and will be entirely separate from the "Methods and Devices Department." Anyone desiring names of firms and addresses will be answered through this department. Comments on answers and previous articles containing good ideas will be paid for.—Editor.

British Trade.

A writer from London wishes to be put in communication with a large Canadian firm wishing to open stores in London, England. The writer has been selling United States machinery for twelve years. His address will be given by writing Canadian Machinery.

Draftsmen.

I have passed the examinations of the I. C. S. in mathematics, mechanics, strength of materials, steam engine design, geometrical and mechanical drawing. (1) Do you think I could hold a position of draftsman. (2) What pay does a draftsman get?

We think you should, if you have been observant in your present position, be able to take up the work of drafting, but of course, you would have to work at small pay until you had proved yourself able to take care of more responsible work. There is practically no limit to the possibilities of a good draftsman, though in starting the salary will probably be from about \$2 per day up.

Tempering Gears.

We would like a safe, simple method for hardening the teeth of steel cut gears after they have been dressed so that warping will be eliminated.

We would suggest that two large washers be used, bolting the gear firmly between them when hardening. This will keep the centre of the gear soft and assist in preventing warping. We would also suggest that the gears be re-tempered just before finishing.

Heat the gears in a muffle, if possible, thus preventing the gears coming in contact with the fire. Heat the gears from 1,500 to 1,550 degs., but not higher. In hardening, the gear may be put on an arbor, letting the arbor rest on the side of the box. The gear can then be turned around in the solution, having only enough solution in the box to wet the teeth. Small wheels are

usually case-hardened by cyanide of potassium. Readers having had experience in case-hardening gears are requested to send in the results of their experience.

Factories Act.

Will you permit me to use some of the valuable space in your paper to make a protest in reference to an amendment that is being made in the Factories Act that any employe injured can start a suit for damages in six months.

While quite in favor of any amendments that make for the safety of employes, yet here is the danger in this amendment, the easier it is for employes to get damages the more careless they become, especially when there are a lot of lawyers who are looking for every little excuse to work up a case for damages. Most employes know that nine times out of ten that injury is caused by carelessness; this should not be encouraged.

A good strong protest on the part of manufacturers would mean that the law would be fixed so that the responsibility would be placed on the right parties, not a case of hold up.

MANUFACTURER.

RE-LIGHTING CUPOLA FIRE.

It isn't often that a cupola fire goes out, but accidents will happen. It was probably the first time in the history of the Canada Foundry Co., Toronto, when their cupola fire went out recently. It certainly was the first in the long experience of E. B. Gilmour, superintendent of the molding department.

It may be interesting to know how the fire was re-lighted. The cupola was filled to the charging door with tons of coke and iron, and a look through the tuyeres showed that every bit of wood had been consumed and the cupola could not be dumped, as there was a large floor of molds ready for the charge to melt.

A steel bar was procured, and the breastwork was knocked out. A generous piece of waste was soaked in oil and pushed underneath the charge. Then with a gas torch and compressed air a flame was kept playing on the waste and coke bed until the fire was started, when the blast was turned on and the melt proceeded with in the regular way.

FIRE-CLAY AGENCY.

Alex. Gibb, 13 St. John St., Montreal has been appointed sole agent for Canada of the Glenboig Union Fire-Clay Co., whose head office is at West Regent Street, Glasgow.

The fire bricks and ground-fire clay of this company are well known in Canada, and under the control of Mr. Gibb a vigorous selling campaign is to be instituted. The success of the Glenboig products is due to the quality of the clay found at Glenboig, Lanarkshire, and the advanced methods, combining care and knowledge, employed in the manufacture. The products of the company have been successfully shown at all the principal exhibitions, and in every case have secured the highest awards, the medals and diplomas numbering 48. About a thousand hands are engaged in mining the fire-clay and in the processes of converting the raw material into all kinds of fire-clay goods, showing the extensiveness of the operations of the company and the demand for their goods from all quarters of the globe.

PERSONAL

F. Horace Disston, lately of Philadelphia, has been appointed superintendent of Henry Disston & Sons' new saw works at Toronto.

J. Hossack, Toronto, sales manager of the Lufkin Rule Co., is visiting the Maritime Provinces and Newfoundland, on a business trip.

F. B. Cowan, manager of the Gananoque Bolt Works, which has been taken into the Canada Bolt Co. merger, will be manager of the two Gananoque branches of the merged company.

W. F. Beardshaw, of J. Beardshaw & Sons, Baltic Steel Works, Sheffield, Eng., is in Montreal, on a visit to Alex. Gibb, the sole Canadian agent of this firm. Mr. Beardshaw will visit several other Canadian cities while in Canada.

Fred Harding, who has been secretary-treasurer of the London Machine Tool Co., Hamilton, since it started was presented with a valuable gold watch by his fellow directors. Mr. Harding is leaving the company to go to Toronto, where he has accepted a position with the Chapman Double Ball Bearing Co.

H. C. Hunt, who has been managing director of Brass & Steel Goods, Ltd., Belleville, since its organization has transferred his interests to W. C. Springer, who will take the full management and direction of the company. It is stated that the Corbin Lock Co. is to take over the Brass & Steel Goods Company's business and the plant is to be enlarged considerably.

According to the Geological Survey, the United States leads all other countries in the conversion of raw asbestos into manufactured products, although much less than 1 per cent. of the material used is mined in that country.

CANADIAN MACHINERY

AND MANUFACTURING NEWS

A monthly newspaper devoted to machinery and manufacturing interests mechanical and electrical trades, the foundry, technical progress, construction and improvement, and to all users of power developed from steam, gas, electricity, compressed air and water in Canada.

The MacLean Publishing Co., Limited

JOHN BAYNE MACLEAN, *President* W. L. EDMONDS, *Vice-President*

H. V. TYRRELL, Toronto Business Manager
 G. C. KEITH, M.E., B.Sc., Toronto Managing Editor
 F. C. D. WILKES, B.Sc., Montreal Associate Editor

OFFICES :

CANADA	UNITED STATES
MONTREAL - Rooms 701-702 Eastern Townships Bank Bldg	NEW YORK - R. B. Huestis
TORONTO - 10 Front Street East	1109-1111 Lawyers' Title, Insurance and Trust Building
WINNIPEG, 511 Union Bank Building	Phone, 1111 Cortlandt
Phone 3726	
F. R. Munro	
BRITISH COLUMBIA - Vancouver	FRANCE
H. Hodgson,	PARIS - John F. Jones & Co.,
Room 21, Hartney Chambers	31bis, Faubourg Montmartre,
	Paris, France
GREAT BRITAIN	SWITZERLAND
LONDON - 88 Fleet Street, E.C.	ZURICH - Louis Wol
Phone Central 12960	Orell Fussli & Co
J. Meredith McKim	

Cable Address:

Macpubco, Toronto. Atabek, London, Eng.

SUBSCRIPTION RATE.

Canada, United States, \$1.00, Great Britain, Australia and other colonies 4s. 6d., per year; other countries, \$1.50. Advertising rates on request.

Subscribers who are not receiving their paper regularly will confer a favor on us by letting us know. We should be notified at once of any change in address, giving both old and new.

Vol. VI. March, 1910 No. 3

LET THE BUSINESS MEN KNOW.

There are bills which come up from time to time in the Dominion Parliament and in the various provincial parliaments which need the expert attention of the business men of the country. Yet these men never see or hear of these bills until they come before the house and then only through meagre newspaper reports.

How simple it would be for the governments to have a list of the boards of trade in Canada and in the respective provinces on file and each time a bill is drawn up to send a copy to each.

Boards of trade are composed of the best business men in the country; they are therefore the most competent men to judge whether a bill is in the best interests of trade or not; they are in a position to suggest changes, omissions, or additions which often make a bill really effective.

A good example of this is to be found in the Secret Commissions Act. If that bill had not fallen into the

hands of a business man who understood what it was intended to do, we never would have had the last clause which makes the party knowingly privy to any offence of the act liable to the same penalties as the giver of the secret rebate.

The boards of trade which represent the manufacturing and all business interests of a community should therefore be in touch with the government and should be made acquainted with what is going on in parliament.

A copy of each bill respecting business should be sent to the president or secretary of each board of trade just as soon as it is in type in order to give the business men an opportunity of studying it and offering their opinions.

BE PROGRESSIVE.

The man who "never did things like that" is gradually weeding himself from the list of successful men in their business and profession. When confronted with the problems of the present and having suggested to him certain courses to pursue, he puts up the plea that he has never done things that way, has heretofore been successful and sees no reason why he should modify, change, or add to that which has made him where he is. He keeps on for a while in the way he is going, and although he insists that he is doing good work, he knows that something is wrong, somewhere, but he still sees no reason for adopting newfangled ideas.

If we can't make up our minds to do the things of to-day as the necessities of the day demands and shape our methods according to the particular requirements of the present, we'll sooner or later find that he who has a way of his own of doing things, and persists in doing things that way under any conditions, will get left far behind in life's race.

A man goes to bed with a clear conscience that he has fixed his business properly for the problems he has contended with during the day, but he wakes up to his business the next morning with some new series or sets of trouble confronting him that demand other treatments.

Ignoring or passing over won't rid his business of the annoyances, and because he didn't have them to contend with 10 or 20 years ago, he fools himself expensively if he attempts to let them go unnoticed and unconquered.

It doesn't make an difference how we did things some other day; the problems of to-day are the ones that demand our attention to-day, and if we don't know how to handle them, it is up to us to find out immediately.

MODERNIZING OLD SHOPS.

The advent of high-speed steels has made many machines in the shop out-of-date. Some foremen, superintendents and manufacturers have found it inconvenient

to make use of the new steel on account of the machines not being able to stand up to their work. Some superintendents have found it advisable to replace the less modern machinery by those of heavier design, and in some cases by motor-driven machines, the older machines being then consigned to the scrap pile. When the efficiency of the shop can be increased to an amount to pay at least the interest on the investment, this is a paying proposition.

In other shops the first cost has been a difficulty in the way and the old machines have been worked to their capacity, which in some cases is very low compared with 1910 practice. Others again by the adoption of several schemes have brought the machinery up-to-date.

Where lathes have four-step cones, they were made into two, the first and third steps being raised to the level of the second and fourth. A belt of twice the width is then used, giving power sufficient to greatly increase the output of the lathe and to obtain the benefit derivable from using high-speed steel. Other machines, including shapers, etc., have been similarly treated.

Increased outputs are obtained with planers by using individual motor drive, connecting them to the planer-driving gear by chain drive or increasing the width of the belt so that high-speed steel may be used.

With the increased speed of the machinery in bringing it up to modern requirements, attention has been given to lubrication. The drilled hole in the bearing is replaced by an oil cup, which keeps the fast-running parts well lubricated.

It has been found in modernizing the machine shop by introducing modern tools and bringing older ones up-to-date, that the capacity of a given number of tools is greatly increased and costs of output have decreased. The modern machine tool, coupled with good management, is a great factor in present-day competition, and the shop that is up-to-date, is the one that produces at a minimum cost.

CANADA'S FOREIGN TRADE RELATIONS.

The surtax of one-third maximum duty on imports from Germany has been abolished, the new agreement taking effect, March 1. We have pointed out on several occasions that various German organizations were interested in promoting better trade relations between Germany and Canada, and the present arrangement between the two governments is the result.

The French Treaty is now in force, as intimated in the February issue of *Canadian Machinery*. Among the French goods provided for in the treaty are:

- 316. Electric light carbons and points, 32½ per cent.
- 339. Mfgs. of lead, 27½ per cent.
- 352. Brass and copper nails, tacks, rivets and burrs or washers; bells and gongs, n.o.p.; and manufactures of brass or copper, n.o.p., 27½ per cent.

354. Manufacturers of aluminum, n.o.p., 22½ per cent.

418. Wire cloth, or woven wire of brass or copper 22½ per cent.

438. Locomotives and motor cars, for railways and tramways; and automobiles and motor vehicles of all kinds, 30 per cent.

Ex 453. Telephone and telegraph instruments, electric and galvanic batteries, electric motors, dynamos, generators, sockets, insulators of all kinds; electric apparatus, n.o.p.; and iron and steel castings, and iron and steel integral parts of all machinery above specified, 25 per cent.

454. Manufactures, articles of wares of iron or steel or of which iron and steel (or either) are the component materials of chief value, n.o.p., 27½ per cent.

The following Canadian products are included among those provided for in the treaty:—

- 205. Cast iron.
- 206. Wrought iron crude, in blooms, prisms or bars.
- 207. Iron, drawn in bars, angle and T iron, axles and tires, in the rough.
- 210. Sheet and plate iron.
- 212. Iron or steel wire, whether tinned, coppered, zincd, galvanized or not.
- 212. Rails of iron or steel.
- 213. Steel in bars.
- 214. Axles and tires rough, in steel.
- 216. Steel.
- 221. Copper.
- 222. Lead.
- 225. Nickel.
- 227. Antimony.
- 488. Transmission belts, etc., of leather.
- 522. Agricultural machinery.
- 554. Iron castings.
- 567. Tubes of iron or steel, not welded.
- 620. Manufacturers of India-rubber and gutta-percha.

In the seven months ending January 31, 1910, United States imported into Canada, goods valued at \$116,130,775. It is to be hoped that the Tariff Commission of the United States will make satisfactory arrangements for the continuance of the growing exchange of products between the United States and Canada.

Canadian trade in January amounted to \$51,500,102, of which total the increase is \$12,322,627. Imports and exports are in the proportion of about three to two, which is a gain of thirty per cent. over the first month of 1909, when the commercial recovery had barely begun. One of the most encouraging features of the ten months' statement is an increase of two millions in manufactured articles exported. For the ten months imports have totalled \$302,050,207, an increase of \$60,978,445.

FOUNDRY PRACTICE AND EQUIPMENT

Practical Articles for Canadian Foundrymen and Pattern Makers, and
News of Foundrymen's and Allied Associations. Contributions Invited.

PRINCIPLES OF MELTING IRON.

By E. B. Gilmour *

The subject which I have chosen is "The Principles of Melting Iron in the Cupola." The name and style of this furnace is derived from a cupola or dome leading to the chimney, which is now frequently omitted.

Cupolas are made in sizes ranging from 18" to an unlimited size in diameter, to suit the requirements of the foundryman, and in nearly every foundry there are two or more cupolas, a small one for every day use, and a large one for specially large heats. The shape and style of cupolas have become more or less standardized with very little difference as regards results, unless when some one in authority is putting in a new plant, and wants one of his own design, and at the same time, if he was put upon his own resources he could not melt iron even in his own cupola. All founders possess more or less knowledge of cupola practice, and mixing of irons. When I say founders I do not mean molders, as plenty of molders do not know anything about the cupola.

The cupola furnace for melting iron has a great advantage over all kinds of furnaces, as it melts iron cheaply and quickly, from a small quantity to an unlimited amount, with very little fuel. The cupola does not improve the quality of the iron melted, but in this age of keen competition, every one is trying to get the best results as regards quality and quantity in their product. The improvements that have been worked on the cupola have been very little, comparatively, with the other improvements that have been added to the foundry. I remember the old style of cupola with the single tuyere on each side, blowing direct into the furnace which gave good results. Now they are built in multiple rows of tuyeres, which is a great improvement.

Cupola Practice.

In good cupola practice there is a loss of heat units to the extent of about 25 per cent., and in order to have perfect combustion, you must supply a sufficient amount of oxygen to the amount of carbon in your cupola, as when a substance containing carbon burns in an insufficient supply of air, oxidation of the carbon is not complete and the product, in-

stead of being carbon-dioxide, is carbon-monoxide, consequently there will be a great loss of fuel, in not using all the heat units capable of being produced, according to the amount of fuel supplied, but if you add at different stages in your cupola more oxygen, it will combine with the carbon-monoxide and produce carbon-dioxide, and in this stage you have as near perfect combustion as it is practical to get, from a cupola.

Too much blast is attended with an increased consumption of fuel per ton of iron melted, which also chills the furnace and causes it to scaffold. On the other hand, too little blast is attended with a loss of heat.

It is not my object, to advertise any particular kind of cupola or condemn any one that is on the market for sale, but to try and outline some of the principles involved in melting iron in the cupola.

After a very careful study, extending over a number of years, both from a chemical and practical standpoint, I designed a cupola with upper tuyeres. I never had the opportunity to erect a cupola as desired, but some years later I was employed with the E. P. Ellis Co., Milwaukee, Wis., who had a cupola of practically the same design which was giving most remarkable records; this was a Whiting cupola of nine tons capacity per hour. Previous to the changes having been put upon it which afterwards gave fifteen tons per hour and giving very hot iron for the finest of machinery castings, with a consumption of fuel of ten to one, this ratio could be easily increased, but in order to get good hot and clean iron you must use fuel, and this is a very exceptional result. We often see in trades journals records of far more phenomenal results than this, but I am sorry to say that they are only upon paper, or if they are in the foundry, you have a proportional large scrap heap caused by dull iron.

Getting Iron Hot.

One great secret in foundry practice is to get the iron hot, which means clean iron. The fact of trying to save a little coke in the cupola is all a fallacy because the price of coke is not of so much consideration, when in ordinary practice you get eight pounds of iron melted for one pound of coke. The principal thing is to get quick melting so that you can get more hours molding. As a rule when iron begins to flow the

molder gets ready to pour, so consequently the longer your heats, the less production.

Description.

For the benefit of those who are not familiar with the cupola I will begin at the foundation and explain how iron is melted. The cupola is practically a cylinder made of boiler plate with holes at regular intervals divided around the shell averaging about two feet from the bottom. This shell is set up on four legs attached to a cast iron frame with two half circled doors with hinges. These doors are held up with a rod or pin from the ground. The inside of this shell is lined with fire brick all the way up to the top in order to preserve the shell. These holes around the shell are called tuyeres, which are connected to each other by a continuous belt around the outside, and it is this tuyere arrangement that gives effective or non-effective melting, as the case may be. On top of the bottom doors there is about four inches of sand gradually tapered towards the tap hole. A fire of wood is started on top of this sand and filled up with coke, up to twenty-four inches above the top of the tuyeres. Between this point and the tuyeres is called the melting zone; this is where all the melting is done. On top of this coke bed an amount of iron is put on, to about 3½ pounds to one of coke in the bed, thereafter another layer of coke and iron alternately, of one to ten, and this is continued until all is charged that is required for that day. On top of each charge of iron is placed about 30 to 40 pounds of lime stone, this makes the slag from the iron and coke very fluid, so that in large heats it is run off, so as to keep the cupola clean.

About two years ago, when the foundrymen were in convention in Toronto, there was a new cupola put upon the market with phenomenal records of melting. It embodied the same principle as I was working in my cupola, but with this difference, that he drew all the gases from the cupola as they escaped over the top of the highest charge with another row of tuyeres at this level. As a consequence he draws the carbon-dioxide gas which is, roughly speaking, the ash of the gases, generated in consumption. Now this is a gas that you want to get rid of. His system is to get the oxygen from the charging door, also the carbon-monoxide from the cupola, which would be hot, and get rid of the clogging of the tuyeres. This

* Superintendent Molding Department, Canada Foundry Co., Toronto.

Statistics of Canada's Iron and Steel Production

Returns Gathered by Canadian Machinery for 1909 show Material Advances over the Totals for the Previous Year.

system has not proved so good as the designer anticipated, as I watched the records and demonstrations for three days, and noticed a very heavy burning out of the upper tuyeres, and the iron was not hot enough for the usual run of light castings. I believed that the saving of fuel was at the expense of the iron.

Melting Irregularities.

In general cupola practice there are a number of irregularities in melting which caused Mr. Hart to make an inquiry as to the cause. This is also in the blast furnace; he says:—"He describes some of the irregularities to differences in atmospheric pressure; thus the range of the barometer in Great Britain being about three inches, or rather more than one tenth of the mean pressure, this change of density would produce a difference of one-tenth in the bulk of the air. And, therefore, between a severe frost with the thermometer at 20 deg. and sultry weather at 70 degrees, the difference would be 50 degrees, and as atmospheric air dilates or contracts one four hundred and eighty-fifth part of every degree, this difference in temperature would produce a variation of rather more than one-tenth in the mass or bulk of the air. So that, if during severe frost the barometer stood at thirty-one inches, while during sultry weather it stood at twenty-eight inches, the combined effects of the differences in temperature and the pressure would amount to a total variation of one-fifth in the bulk of the blast, which would be nearly equivalent to a careless furnace man putting into his furnace ninety pounds of coal instead of one hundred. During a whole casting, indeed, the difference from temperature and pressure amounts to something like an irregular charging of the furnace with ninety pounds indiscriminately, instead of one hundred pounds regularly."

These observations of Mr. Hart are certainly worthy of attention. The impression of the effect of moisture in the air is still as firmly held as ever. Taking the average of five years, selected at intervals of the same period, for twenty-two years working, the following quantities of coal were consumed for every ton of crude iron produced:—

	Winter Cwt.	Spring Cwt.	Summer Cwt.	Autumn Cwt.
Foundry iron furnace.	49.7	52.2	53.1	55.4
Forge iron furnace...	43.6	44.2	44.6	45.8
Blast furnace iron...	43.2	44.1	50.1	49.5

In the first, or foundry iron furnace, the excess of autumn over winter months is eleven per cent.; in forge furnace equal to five per cent., and in blast furnace fifteen per cent.

Although Canada's iron and steel productions for 1909 may not show such tremendous increases as reported to have happened in the United States, yet the authentic figures—now first published—indicate a marked improvement over those of the previous year. In every line there has been a significant advance, and the gratifying totals which we anticipated at the publishing of our half yearly statement have been more than realised. Taking iron and steel as the best trade barometer that a country can possess, it is evident that Canada had a good year, and starts in the best of shape for making 1910 the best of all.

20 to 30 Per Cent. Gain.

A glance at the appended figures shows that the total pig iron production for last year was 112,648 tons better than for 1908, or nearly 20 per cent., while the ingot production was 164,360 tons, or over 30 per cent. Considering that the improvements taking place in the various plants were, in but few cases, sufficiently advanced to be of any great help, it can be understood that the pressure of all this increased production must have been very great. In fact, for several months the furnaces were not looking for orders, and delivery was hard to obtain. The congestion in steel was likewise severe, especially as two of the great producers were out of the open market, having all they could do to look after their own wants.

Detailed Figures.

Of the detailed figures of the iron production it will be noticed that while they all show advances, Bessemer, with an increase of 47,772 tons, or over 40 per cent., and foundry with an increase of 25,109 tons, or over 30 per cent., are most prominent, that is so far as comparisons with the previous year are concerned.

The steel figures show great and significant increases. Wire rods for instance, show an increase of 31,582 tons, or 76 per cent.; bar steel, iron and structural material, 39,074 tons; rails, 69,969 tons, while plate, axles and sundries, etc., show the greatest comparative increase of any, that of 3,381 tons, or over 100 per cent. Castings also are very prominent, with an increase of 4,610 tons or nearly 50 per cent. It is evident from this that all classes of consumers have been active buyers.

Twelve furnaces were in blast compared with eleven for the previous year.

The Canada Iron Corporation are building an additional furnace at Mid-

land, Ont., which will go into operation in about three months.

The Algoma Steel Co., in addition to the new furnace and mills now in course of construction, are also adding coke ovens to be built this year.

The Deseronto plant of the Standard Chemical Co. will be improved by an ore trestle, and the instalation of an electric motor in the ore dock. Canadian Machinery has already published details of the additions now in course of construction at the Dominion Iron & Steel and the Hamilton Iron & Steel.

The Year's Figures.

	Year ending Dec. 31 1908.	Year ending Dec. 31 1909.
* Total iron production..	566,515	679,161
Total ingot steel production	511,569	675,929

Details.

Pig Iron—		
Basic	345,494	362,947
Bessemer	116,230	164,002
Malleable	18,293	29,500
Foundry	81,932	107,041
Steel—		
Ingot	511,569	675,929
Blooms	370,563	472,126
Billets	105,473	139,335
Rails	267,377	337,346
Wire rods	41,420	73,002
Bar steel, iron and structural material..	81,984	121,058
Castings	9,350	13,960
Plate, axles, spikes and sundries	3,140	6,521

The Osborn Mfg. Co., 5401 East Hamilton Ave., Cleveland, have issued catalogue No. 124 describing their adjustable flask stripping molding machine. The machine is made in three sizes and each size can be adjusted to four standard widths of flasks and any length as may be required.

Patterns are mounted on a metal or wood pattern plate. The cast iron flask supports on either side of the machine are adjustable sideways, these adjustments being graduated to 1/2 inch spaces, and in addition, the surface plates on top of these flask supports are also adjustable sideways to accommodate the machine to any trifling irregularities in flasks of standard sizes.

A full description with illustrations is given in the catalogue. Several other molding machines are also described. The catalogue will be sent on request.

SUGGESTED CHANGE IN CUPOLA PRACTICE.*

By Dr. R. Moldenke, Watchung, N.J.

In the last few years considerable has been written on the subject of imperfect castings, and many and varied have been the reasons advanced to account for the existence of pin, gas and slag holes, interior shrinkages, draws, cracks, and the like. The supposition that these undesirable manifestations are solely due to molding troubles, bad sand, air in the molds which can not escape fast enough, bad design, or an improper mixture of metal, does not always convince the experienced foundryman. He has, however, no other recourse than to correct what he can in his practice as he sees it, and trust that he will soon run out of his bad run of luck. Usually by the time things begin to get irritating, the castings have all been made, and the trouble is forgotten for the time being.

For a number of years it has been my feeling that aside from causes easily seen and remedied, the fundamental difficulty in nearly all cases of imperfect castings lies deeper and may be found directly in the manner in which the stock is melted down. In other words, that there is something about every melting process, whether cupola, air furnace or open hearth, that must be taken into account, otherwise a greater or less number of the castings made will show spongy spots, pinholes, etc., when machined.

It is the purpose of this paper to go into the subject a little, to try to give the probable cause, and suggest a remedy for much of the above mentioned trouble.

Foundrymen will remember that several years ago a very elaborate series of cupola melting tests were made at the Government testing plant in connection with the St. Louis exposition, and the year thereafter I was in charge of this work, and present at nearly every individual test, and hence could observe the peculiar behavior of the several cokes tested out. A large number of cokes made on the premises from coals gathered all over the country, and selected specially for their probable usefulness for foundry purposes, were run through two small cupolas under standard conditions, and results noted. The series of tables subsequently published, while giving the coal producer information of direct value to him for his special use, also demonstrated a number of things for the foundry which would have been impossible to get in ordinary practice, as no one individual could afford to

burn up a lot of valuable iron in order to derive information therefrom.

As these tests really form the basis for what is to follow, a few words in further explanation may not be amiss. The Technological Branch of the U.S. Geological Survey coked a great number of coals sent in by producers all over the country. Wherever these cokes showed a composition anywhere near foundry requirements, some were set aside for melting tests. In all some one hundred and ninety tests were made. Three thousand pounds of metal were melted in each test. In order to have uniform conditions for the coke bed, and still suit the average coke made, fourteen inches above the lower tuyeres was selected, and this height kept for every test. The upper tuyeres were kept closed. A melting ration of 7 to 1 was adopted. The coke used for the bed was weighed as put in to the proper mark. In this manner, measuring the height of the bed by a wire and weight dropped in, the exact amount of coke used could be noted. This weight varied from 180 to 230 pounds, showing quite a range in specific gravity. Four times this weight was charged in metal for the first charge, and the successive charges of coke and metal remaining to hold the ratio at 7 to 1 divided up into four parts, coke varying from 50 to 62 pounds, and the metal correspondingly.

Blast was put on—about 7 ounces—and the time noted when iron began to show at the spout. Iron came in 5 to 15 minutes. This is interesting as indicating the rate at which coke was consumed, and the iron brought into the melting zone. With the best results the iron came in 7 to 10 minutes.

Necessarily for the extremely light and the unduly heavy cokes this melting practice would spell disaster, and it did so, the melting loss showing this up very markedly. Possibly this may convince many foundrymen who think it impossible to burn iron in the cupola. The results show this melting loss to be from 3.2 all the way up to 52.5 per cent. of the metal charged. The cupolas were constantly slagged off, but in the worst case above mentioned, so much slag was made that it flooded the tuyeres, and effectually stopped operations. When bottom was dropped, there was no metal remaining. It was quite evident that with the lighter varieties of coke, they burned away so fast that the metal came to the lower portion of the melting zone much earlier than it should. Hence metal was burned directly by the blast. The first heavy charge, in melting, lowered this coke bed to a point which not only ruined the metal melted, but also prevented the

subsequent charges of coke from restoring the bed to its proper level again. The burning therefore continued, and a very bad heat resulted.

Heavy Cokes.

Now taking the very heavy cokes. Here it was necessary to wait quite a while before the bed had burned low enough to begin melting. Necessarily to keep the ratio of one to four for the first charge, a very heavy one resulted. Here again the coke bed was lowered unduly in melting this first extra heavy charge, again bringing the metal too close to the blast. Result—burnt metal. The trouble in such cases, however, was aggravated by the fact that the subsequent coke charges were very small—too much having gone into the bed and being burned away without effect, remembering that the ratio of 7 to 1 was maintained in the heat. Hence again difficulty, and bottom dropped with a lot of unmelted pig iron remaining. The fuel became insufficient to even support the Bessemerizing influence of the blast.

So it will be seen that where the melting process with a given coke and conditions normal gives good iron, it does not necessarily follow that any other coke will act the same, and hence many are the mistakes made in using new varieties of coke in a foundry without studying the conditions that should obtain to get results from them.

Burning Iron.

A word about burning iron in the cupola. Those who have watched the making of the iron silicates can realize how very little silica can carry great quantities of iron to make a thin black slag. In the heating shop where steel or wrought iron billets are gotten ready for the hammers, this process can be watched very nicely. The regenerative system of heating the modern furnace keeps things intensely hot in them, and as the billets become red and then white hot the metal oxidizes and wastes away rapidly, uniting with the sand bottom to a rich silicate, which flows out of the back of the hearth in a steady thin stream. This material is prized by the furnace as a wash and is easily 60 per cent. and over in iron content. In the bottom of the open hearth furnace, after a malleable heat, oftentimes pools of iron remain which rapidly oxidize, burning with a display of fine sparks, to disappear after uniting with the sand bottom as a dark spot on a fiery surface. Of the Bessemer process nothing need be said here, as the burning of the metal is a self-evident proposition, though theoretically the iron goes last. In the blast furnace one has only to note that

* Read before American Foundrymen's Association.

the same sized furnace which produces 250 tons a day under one set of conditions, and makes good honest iron for the foundryman is made to yield double the amount in another place, with a corresponding diminution in value to the foundry. Some of the metal made gets oxidized before arriving in the crucible. In the cupola it is a simple thing to watch the scintillations from the drops of iron falling through the coke bed. Every little shot is thus coated with a skin of oxide as it passes the fresh blast and goes into the bath below. Just how much this oxidation amounts to depends upon the position of the stock with reference to the melting zone, as the material runs off molten.

Whether the blast attacks the lining and this eats up the oxidized metal, or the oxidized metal unites with the ash of the coke, needing so little silica, matters very little. The slag formed eventually gets blown upward and to the sides, the rich iron oxides greedily eat the lining, and great quantities of slag result. In the case above cited where the melting loss was over half the metal charged, the slag contained 43.50 per cent. iron.

A study of the St. Louis results leads one to look into the melting process a little. Melting in the crucible has always given the best results, and simply because the oxidizing influences are at a minimum. In the air furnace, proper attention to the melting, and doing away with the thin edge of molten metal on the sand bottom, by making this approach the open hearth shape more, does away with much of the oxidation resulting in weak metal. In the open hearth as well as the air furnace, the reduction of the time in melting does more than anything else to keep the quality of the metal up. To reduce this melting time means a first-class knowledge of the process.

In the case of the cupola things are more complex. It is necessary to see what functions each part of the operation serves. Take the coke bed; this may be divided into three parts. The first is that portion below the tuyeres which serves as a filling. It occupies the space intended to hold the molten iron, and holds up the balance of the charges. The second portion of the bed is that just above the tuyeres and up to the zone of melting. In this space the blast has its oxygen more or less converted to carbonic acid and carbonic oxide. The third portion is incandescent coke at which the actual melting takes place. The second and third portions of the coke, of course, shade into each other, the temperature of the coke rising from the comparatively dull heat of the bot-

tom filling, to the hottest part at the melting line. As the metal melts, this line—if it may be so called—naturally drops downward, and when all of the first charge is gone, the first intermediate coke charge gets on the bed, bringing it upward again. The second charge of iron is melted, the bed dropped in so doing, and again the next intermediate coke charge brings it up again. And so on. On the nicety of the charges depends the rate of melting, melting loss, and a number of other things.

That practically only the portion of the coke above the tuyeres does any melting is proven by the fact that in many foundries where it is not desired to hold any metal in the cupola at all, the tuyeres are placed a few inches from the bottom. Again, that the lower portion of the coke above the tuyeres is also not effective for good is shown by the damage done when the iron gets too low. Hence the upper part only of the coke charge should be counted as effective, and study be given it to see how it can be made most so.

Coke Bed.

The first question that presents itself to the thinking mind is why—if only the upper part of the coke bed does the melting, and this part being used up in so doing, is replaced by the small coke charge above—why is the first charge in cupolas made heavier than the rest? It seems unreasonable, in fact absolutely incorrect to do so. Think a moment—iron does not begin to melt until the coke has burned down to the proper point. It takes more coke burned away after melting starts, to care for a big first charge, than for a little one, such as the ones subsequently used. Therefore with the big charge, the coke bed has been lowered so much that the subsequent coke charge does not restore the bed to its original height—in fact far from it. The second iron charge therefore does not begin to melt where the first one did, but much below it. Result—burnt iron in both cases. This goes right on for every succeeding charge, the latter end of each being too low and near the blast which at this low point contains a lot of unconsumed oxygen. Usually we find that the intermediate coke charges are just a little large, and gradually the line of melting is brought back to where it should be, and hence the burning trouble is confined to the first part of the heat. One often hears that toward the end of a heat the iron comes slow, and by cutting the coke in the last charges a little, quicker results are obtained. This is simply due to the extra large coke charges bringing the bed above the melting line, and

hence coke must be burned away to get the iron into the proper place again for melting.

The conclusion that one must come to—if the reasoning is correct—is that the first charge shall be no larger than the others succeeding.

Charges.

The second thought that comes from this is the natural result of the first, and that is—if the unreasonable fluctuation of the melting zone produced by an excessively large first charge does damage to the metal, then why not make all the charges not only alike, but as small as it is possible to make them, in order to hold the melting line as constant as possible.

Herein lies the change I suggest in cupola practice as it is carried on to-day. I have tried this method repeatedly in the last year with remarkable results, nearly all the imperfections mentioned in the beginning of this paper being wiped out wherever the charges were made very small, the bed started off at the right height, and that the intermediate coke charges proportioned in such a way that uniform melting resulted throughout the heat, and of course the chemical composition correct, and charging and melting accomplished with care.

The bed may be accepted as of proper height when iron comes at the spout in seven to ten minutes, the latter time being preferable. The charges are made so small that the proportionate amount of coke between just covers them and no more, say from two to four inches in depth. The ratio of iron and coke is kept just the same as previously in starting off this way, except that after deducting the coke for the bed from the sum total of coke charged, all the iron and all the coke left is divided up into equal and small charges. After running a while it will invariably be found that the coke can be reduced somewhat as the small charge system keeps the melting so uniform that the fuel formerly used in making slag and keeping it hot, is applied for melting iron.

It may be of interest to say that with cupolas of about 54 in. inside diameter, the metal charges have been made as low as 750 pounds each, and with admirable results. In general however, it is well to be guided by the coke between the metal charges, keeping this down to the smallest convenient amount, and making the metal charges proportionate to hold up the melting ratio. In this way there is a quick succession of coke layers to keep the bed right up to the proper level. In no case is the metal

Modern Practice in the Pattern Shop and Foundry*

Old Methods Have Passed Away and New Ideas have Revolutionized Patternmaking, Making Possible Great Savings in the Foundry.

By JOS. LEON GOBEILLE **

charge so large that the melting line is lowered very materially, and hence a minimum of iron is burned. The consequence of this is the practical wiping out of pin holes, the removal of draws, gas pockets, lessening of strains which mean cracks, and the closing up or rather prevention of spongy metal. All this, of course, not in its entirety, but in so great a measure that the discount is lowered to a highly gratifying extent. I could name case after case, where upon being called in to assist over much difficulties, this simple and logical—I think it—charging method, has accomplished everything that could be desired. I take pleasure, therefore, in giving it to the foundry public, for their criticism and trial if they choose to do so. It may help someone who has castings to make which are machined and put under pressure tests.

I need not call attention to the greater uniformity in the mixture attained by this small charge method. This alone would commend it to the smaller jobber, who oftentimes has either no bull-ladle, or a very small one, holding say half of a charge only.

My own suggestion for charging a cupola, especially for big heats, would be somewhat on the following line:—Have the cupola cut off, say six in. above the platform, and arrange a hood further up to draw off the gases. (This I believe is done in England in some places). Have a large cylinder slightly smaller than the inside diameter of the cupola, and provided with a drop bottom. Place the charges for the cupola inside this cylinder, or several of them, laying the metal, scrap and coke evenly and carefully. Do this in your metal yard. Then transport to the cupola, run directly over it by some overhead method, and drop the charges squarely into the cupola. This will reduce the platform labor to next to nothing, allow the charges to be weighed by crane scale overhead, and laid right, and mean only one handling in the yard. It would be mechanical charging in its best sense, and rather more effective than the present blast furnace hoist. Moreover, charging could not well be made any cheaper.

COMMON SENSE.

This question was asked upon an examination paper: "What steps would you take in determining the height of a building, using an aneroid barometer?"

The answer was: "I would lower the barometer by a string and measure the string."

This is a transition period in patternmaking as it is in the foundry business. The most curious thing about us humans is our indifference and unalertness to change. The telephone came and altered all accepted precedent; nobody noticed it. The automobile crop is right now of more value in dollars than that of cotton or gold. The flying machine will be common when next we meet. So with the venerated and venerable pattern-shop. The molding machine is also coming, mighty fast, too.

Passing of Pioneer Practice.

The old folly is passing of setting a mechanic in wood to make a rigid model of some intricate casting which will be, not fabricated at all, but poured in liquid. This foolishness is about to depart along with "How to temper copper" and "Who was Cain's wife?" The pattern-shop of our boyhood had its traditions, but it has come to pass that the man most learned and expert in those ways is really the least important thing in the pattern-shop of today. Why, there is almost no gearing used in this century—everything goes by belts, ropes, friction or is "direct-connected." Gears of precision are cut anyway and a lot are not metal at all, only rawhide. So the pattern-shop need not keep an expert gear-maker. Cast-tooth gears from patterns are no longer called for. If they were wanted, we have a fine gear-cutter more accurate than any mere man, doing nothing most of the time.

Concrete Patterns.

After fooling away a lot of time I decided to add a separate department and make some patterns out of concrete. In an Italian image-maker's shop on Chestnut Street, Philadelphia, I found my man. He was "a artist" and was very much surprised and grieved when I started him on a housing to weigh about 16,000 pounds instead of on a group of figures, Cupids, Psyche, etc. My man was just a little different from the common or garden variety of patternmaker. He did not know it all and he was a fine, honest worker. He furnished his own reinforcing. I learned since that in an old steel mattress, which he picked up on the dump and

hauled to the shop himself, and a few feet of barbed wire appropriated from a chicken fence in the suburbs, he had procured the best kind of reinforcing and bothered nobody.

Now for the part that will interest you. A housing priced at a wage cost of \$432, my Florentine friend got out for \$71.60 and we made a good casting from it. I was paying him \$9 a week, so much to his surprise, I raised him to \$2 a day. He is now not afraid to tackle a water-jacketed automobile cylinder or a cast-together tandem-compound, core-boxes and all. To get his water-course and steam-port section superficies, he pours the core-box with plaster, saws one-inch sections from the cast and weighs these sections against 1-inch cubes of the same plaster used as weights on a common candy balance. It is obvious that the number of cubes necessary to balance any slice represents the number of square inches of superficial area in that part no matter how crooked or intricate the out-line may be. So we built a dog-house to our pattern-shop and put into it this man with two helpers, who will themselves be experts in a year or two, on \$6 and \$7 per week respectively!

Now when so many molding machines are in use it is desirable to short-circuit, working not from the blue-print to the pattern but directly to the plate itself. Instead of all the expensive iron and brass patterns with two shrinks to allow and the thousand chances for inaccuracy, we must arrive by carving or modeling the piece wanted in one shrink and working directly onto the plate. This in practice necessitates another dog-house for a first-class white-metal molder. It should adjoin the concrete man's room.

I may confide in you to this extent: my plaster man was from sunny Italy, my molder from the land o' cakes. What a Scot will say out loud about a Dago, and what a Florentine thinks about a Glasgow man, is not suitable to put into words before this respectable company. What to do, well I didn't know. Finally, I worked most of my plates with a Hungarian green-horn in charge. He molded lovely plates but was slow.

Jolt Rammer Introduced.

One wonderful thing about present-day pattern-shop practice is due to the

* Address before Pittsburg Foundrymen's Association.

** Address, care of Gobeille Pattern Co., Niagara Falls, N. Y.

rise of the jolt-rammer. It is possible to handle boards 36 by 48 inches in at least one of the new machines and make anything at all, large or small. After two years' pretty close connection with the jarring type I am convinced of its entire practicability for small and light work and for stove plate, as well as for heavy castings. The man in charge must know how to run it just as in everything else, the automobile for example.

The trouble with the jolt machine is that it needs common sense to get results and common sense is scarce. Think a moment. That bump-bump-bump, 19 times, bumps something else besides the sand, flasks, bars, patterns. All catch it and must be made with a degree of strength and accuracy not demanded elsewhere. Make your flasks of solid iron, no joints at corners. Make them absolutely interchangeable, tool steel pins ground to 1,000th of an inch and fitting a 1,000th of an inch tapered reamed hole. Have them so accurately made that any cope will fit any drag.

Man and Molding Machines.

Don't get it into your cosmos that the man running the machine needs any special mental endowment. I tried a mechanical engineer, graduate of a good technical school. No go! He couldn't even shake out cores in the old jolt-rammer. So I hired a Russian who combined the trade of button-hole maker with a physique which stamped him a veritable Vulcan. He was a greenhorn and spoke no language but Russian except a few Hebrew swear-words. All the conversation I ever had with him was this, bump-bump-bump-bump-bump-bump-bump. He understood and could even increase the number of jolts, if his air was down 20 or 30 pounds, without any profanity on my part. That was one qualification. The second was, he was so big and strong, so bearded and so fierce-looking, the molders were afraid to rough-house his machine or him. Once when he lost a mold because some molder had buried a sponge in his sand he wrecked three of the foundry windows and broke two shovels with his hands. That was enough, Strosky never was called upon to jar-ram any more sponges. I pacified him, but dreamed of button-holes and wrecked foundries at intervals for weeks afterwards.

Advantages of Jolt Rammer.

Another advantage of the jar-rammer in combination with the concrete man might be illustrated in this way. We wanted a shell-like casting for a gear-case. We modeled this in clay and took an impression in plaster of the male side which was to be our drag. We then made a reverse, by processing, and

poured a female from which we made our cope. These were poured in hardened concrete in an iron flask, allowed to dry, rammed up separately, put together and poured from hand ladles. We never had a pattern, but got a fine perfect casting. Size was about 18 by 38 by 13 inches deep, 22 indentations, bosses and oil courses, irregular in shape, $\frac{3}{4}$ inch thick, weight 228 pounds, cost of patternmaker's time \$9.20, and all from a blue-print one-quarter size.

Another photograph from life! A certain 60-inch pipe bend, T-valve and end connection, cost \$628, and was destroyed by fire. The insurance companies settled. We replaced the patterns (from castings) in concrete for \$52. The adjuster came around and saw the finished job. Here is what he said, "Does this stone work cost much more than cherry?" "No." "Not half as much again does it?" "No." "Well, it's worth it, makes a harder pattern and can't burn," said the adjuster. In that one item the poor unfortunate foundryman who had the fire sold out to the insurance company so as to make a clear profit of \$576 on an investment of \$52.

If your flasks are right you can get a hundred castings from an ordinary concrete pattern and then make a new one for less than you could patch up, varnish and store a wood pattern. Gentlemen, believe me, the reinforced concrete pattern is a wonder. I have no monopoly of it. Buy a barrel of cement collect an Italian and try it out for yourself.

The way to keep things even or to change work on the big jolt-rammer is almost too simple for words, only it seems that nobody gets onto it. Make a standard plate for all small work, 12 by 16 inches. That will be nine for each big board, 36 by 48 inches. These multiples are interchangeable and bolted in place, so when one casting runs ahead, take out its multiple and replace with something else, or if it runs short make an extra plate, substitute for something not pressing and double the output. Very simple, and this is now being worked out in practice.

Non-shrink Alloys.

One word about alloys. There is now on sale a metal that is practically non-shrink, but what the new era patternshop wants awfully bad is a white alloy that will take solder and expand in cooling $\frac{1}{8}$ inch instead of contracting that fraction. Think what that would do for you. A casting from a broken casting would make an absolutely accurate working pattern.

I have made in vain a hundred mixtures seeking this Philosopher's Stone. When it is discovered the stove founder

will go into deep mourning, for patterns for repairs that will fit any given stove could be made from the casting itself or a new pattern stove duplicated in its entirety exactly right in size.

Water expands thus on cooling; a cubic foot of water makes a nice plus in volume when it cools to ice. What else does? Especially what other material which combines with copper and aluminum?

Cutting Expenses.

Finally, gentlemen, if you do not believe in radical changes, I can suggest three things which will cut down your pattern expense very materially:

First comes the rearrangement of your tools. To-day in most patternshops the tools are put in helter-skelter—a skilled workman will put in more time walking and carrying his lumber than in the actual operations involved. Change the disposition of your tools so that the natural operations may be sequential. Nearest the lumber racks the cut-off saw; then the big jointer, the surfacer or pony planer, next, your combination cross-cut and rip-saw, band-saw, jig-saw, segment-cutter and your big trimmer, in the order named, and have one of the new toy jointers conveniently near the bench of every man. They are twice as helpful as any trimmer.

Specialists in Pattern Shops.

The second source of saving is in having a good foreman. A bright, ambitious, young man just out of his time, who has taken a course in mechanical drawing, makes a splendid man for foreman. Do not select one who knows too much about patternmaking, or depend on him for carrying out intricate valves or cored work. He can hire men for 40 cents per hour who know all about such details. A young man right out of a good technical school makes a splendid foreman, one who will get out work and keep accurate cost accounts.

My third suggestion is a careful division of labor; if you run more than 25 men you will be able to save more than 25 per cent. right at the start.

Get a good turner and allow him to do nothing else. A good man on beds and housings, give him a gang of five men to help him and keep him at that and similar work all the time. The same with cylinders, small valves, parts, fittings, etc. Each man at what he can do best with cheap help will cut your average wage rate 15 cents per hour.

Many of your men run big shops. Have in them nothing but the group or gang system with a mill gang, dimension gang, assembling gang, finishing gang, and a varnishing gang.

INDUSTRIAL ^A_N^D CONSTRUCTION NEWS

Establishment or Enlargement of Factories, Mills, Power Plants, Etc.; Construction of Railways, Bridges, Etc.; Municipal Undertakings; Mining News.

Foundry and Machine Shop.

The Central Foundry will build an addition to their foundry at Port Hope.

Mackenzie & Mann will operate a smelter and iron works at Victoria, B.C.

The Northern Foundry & Machine Co. will erect a pipe foundry at Winnipeg.

The Western Sheet Metal Works, Vancouver, will build a \$2,000 additions to their plant.

The St. Lawrence Car Works, Quebec, will erect a plant in that city with a capacity of 600 cars yearly.

The C. T. Reineck Co. will build a \$100,000 plant in East Calgary to manufacture stoves and kitchen ranges.

The Lidgerwood Mfg. Co., New York, will erect a plant for the manufacture of logging machinery, at Lachine, P. Q.

The C.P.R. will remove their machine shops from Wellington, B.C., to Vancouver island, as soon as a location is secured.

The present premises of the Steel Wire Works at Guelph are too small for their increasing business, so they will extend.

Plans for the John Deere Plow Company's building at Saskatoon are nearly completed. Construction will begin March 1.

Brownell, Lindley & Co., Manchester, Eng., manufacturers of engines, will establish a branch of their business at Montreal.

The Canadian American Gas and Gasoline Engine Co., will erect a foundry and machine shop at Dunnville, Ont., to cost \$45,000.

The C.P.R. has purchased four hundred acres adjoining Souris, Man., presumably for a shop site to serve the southwestern lines.

Owing to increased business the International Harvester Co. has decided to spend \$100,000 in making improvements to its plant at Hamilton.

Joseph E. Gamache and Victor Langelier have been registered as machinists at St. Hyacinthe, Que., under the title of Gamache & Langelier.

A movement is on foot to move the West Lorne foundry at Glencoe, Ont., to Rodney and run it under a joint stock company capitalized at \$10,000.

The Gould, Shapley & Muir Co., Brantford, have let the contract for their new machine shop and erecting room which will be 180 x 132 feet.

Work is being commenced on the new C.P.R. car repair shop being built to replace the one destroyed by fire at Nelson, B.C. Estimated cost, \$3,500.

The Vulcan Iron Works, Winnipeg, has purchased 20 acres adjoining the Dominion Bridge Co.'s works for \$60,000, in order to provide for future extensions.

Additions will be built to the plants of the Otis-Fensom Co., the London Machine & Tool Co., and the Canadian Drawn Steel Co., all located at Hamilton.

The Charlottetown Foundry & Machine Co., Charlottetown, P.E.I., have sold their business to Bruce Stewart & Co., and the latter company has been incorporated.

The Corbet Foundry & Machine Co., Owen Sound, manufacturers of factory trucks, dry kiln

trucks, municipal steel bridges, intend enlarging their plant this year by the erection of a new machine shop.

Following a recent visit of the officers of the Gananoque Spring & Axle Co. to their Chatham plant, formerly the Dowsley Spring & Axle Works, it is announced that a new office will be erected and much new machinery installed, the outlay amounting to probably \$15,000.

An extension of the ornamental iron department of the Canada Foundry, Toronto, is in course of construction, which will cost about \$50,000 and increase the capacity of the department by 25 to 30 per cent. It will be completed in April when the present force of 225 men will be increased to about 300.

The Kingston Shipbuilding Co., which takes over the Government dry dock, on April 15, is making preparations to erect a large building for shops. The structure will be 120 feet long, and two storeys high, it is understood. All the most modern machinery is being purchased, and will be shipped there shortly.

John Millen & Son, Limited, Montreal, have been appointed sole Canadian agents for the Chisholm & Moore Manufacturing Company's line of chain hoists and trolleys. The chief of these is the "Cyclone" high speed hoist with self-lubricating bearings. The other hoists include both the screw and differential types.

Official announcement is made that a syndicate, composed of E. R. Wood, Toronto, Clarence J. McCuaig, Montreal, and R. Harmer, Toronto, have concluded arrangements by which they secure control in the Sawyer-Massey concern of Hamilton, one of the largest manufacturers of threshing machines and engines in Canada.

The first annual meeting of the shareholders of the Brantford Steel Range Co. was held early in February, when a careful survey of the year's work was made and everything found in a satisfactory condition. It was decided to increase the capital stock of the company and A. L. McPherson was appointed secretary and general manager. Mr. Stamford is being retained as superintendent. The old board of directors was re-elected as follows: President, John Muir; vice-president, L. W. Ryerson; treasurer Geo. H. Wilks; Jos. H. Ham and W. R. K. Stamford.

The annual meeting of the James Pender Co., wire nail manufacturers, was held on Feb. 2, when the following officers and directors were elected:—G. S. Fisher, president; H. R. Sturdee, secretary-treasurer. James Pender, managing director; Joseph Findley, J. Fraser Gregory and J. B. Purdy, additional directors. An offer was made to the stockholders by Montreal capitalists interested in the new Lake Superior Milling Co., at Fort William, to purchase the stock of the company at \$215 per share. The par value of the shares is \$100 and big dividends have always been paid. An offer has also been made to Mr. Pender to assume the management of the new company at Fort William and the decision of the stockholders to sell their holdings will depend largely on whether or not Mr. Pender goes to Fort William, though even in that case he would still be the real manager of the St. John company, which would be the maritime province branch of the other. Although the stockholders are reticent about the offer, it is understood that those who desire to buy are offering 75 per cent. in bonds and 25 per cent. in stock of the new company.

Municipal Undertakings.

Another reservoir has been recommended to be built at Kamloops, B.C.

Edmunston, N.B., has agreed with the G.T.P. to put in a waterworks system.

The New Westminster council will advertise for new tenders for the city incinerator.

The civic officials of Fort Erie, Ont., favor the construction of a waterworks system.

The Board of Control at Hamilton awarded to the London Brass Co. the contract for the brass work for water mains at \$3,000.

City Engineer Rust, of Toronto, in his estimates for 1910 asks for \$225,151 for new fire and water mains.

Vancouver will this year add from 14 to 25 miles to its waterworks system. Mains will be constructed on 40 streets.

J. Galt, consulting engineer, has reported in favor of a project to instal a gravity system water supply at Edmonton.

For the repair of the Third Avenue sewer at Vancouver \$2,100 was set apart; and \$1,000 will be expended in continuing the sewer on York Street.

City Engineer Ker, of Ottawa, has laid before the Board of Control a drainage scheme, which will take three years to complete, and will cost \$350,000.

Tenders are being called for by J. W. Truesdale, city clerk, of Saskatoon, Sask., for materials required for house sewer and water works service connections, etc.

Calgary water commissioners recommend that a by-law for \$242,000 be introduced and submitted for a vote of the ratepayers for the construction and extension of water mains in that city during 1910.

The Hamilton Works Committee passed estimates amounting to \$356,000. Among other items were: sewers, \$11,150; waterworks expenses, \$65,250; sewage disposal, \$19,154; waterworks construction, \$94,000.

Structural Steel.

Strickland Bros. got the contract to erect a foot bridge attachment to the C.N.R. bridge at Saskatoon.

The Laurentian Construction & Engineering Co. were awarded the contract for a bridge at Adamsville, Que.

The sub-structure for the Wolf Creek bridge at Edmonton, will be ready for the steel early in the spring. Chas May is the contractor.

The Dominion Bridge Co., Lachine, have been awarded a contract for structural steel for power racks and tail race bridge by the Canadian Light & Power Co., of Montreal.

The Great Northern Railway have given orders to their engineers to prepare plans for permanent steel bridges over the railway cuts across Park and Victoria drives at Vancouver.

City Engineer Rust, of Toronto, recommends a new bridge at Turner's baths, Toronto Island, to cost \$9,268; Dundas street bridge widening \$19,000; Park Drive bridge, \$5,000; and Weston road bridge, \$30,828.

CANADIAN MACHINERY

Electrical Notes.

The St. George Electric Co., Sherbrooke, will build a new concrete dam and electric plant on the Chaudiere river.

It is reported that the provincial government will spend about \$20,000 on the telephone plant at Prince Albert.

Kenora will pay out \$80,000 for a municipal power site. The Hudson's Bay Co. receives \$45,000 and the Keewatin Power Co., \$35,000.

The Toronto Board of Control decided that the City Engineer should build the electric pump building at the high-level pumping station by day labor.

A by-law to raise \$77,000 for the erection and development of a municipal power plant at Renfrew will be submitted to the ratepayers in the near future.

The Revelstoke, B.C., council have decided to enter into a five-year contract to supply the C. P.R. with power. A new power plant is being installed by the municipality.

General manager Nichols, of the Canadian General Electric Co., states that between \$250,000 and \$750,000 will be spent on new buildings and equipment at Toronto or Peterboro.

F. Barber & Son, of Meaford, are installing a second set of water wheels at Croton for the Delhi Light & Power Co. A new Canadian General Electric Generator is also being installed.

Contracts involving an expenditure of \$53,000 have been awarded by the B.C. Electric Co. for their first unit at Jordan River. The John McDougall Caledonian Iron Works Co., Montreal, have the contract.

An important extension to the N., St. C. & T. Railway will be built this spring, when a line will be constructed from Port Colborne to Fort Erie and Bridgeburg, connecting Niagara-on-the-Lake with Crystal Beach.

Railway Construction.

The Canadian Northern contemplate spending \$5,000,000 on terminals at Montreal.

The C.P.R. intend double-tracking their road between Winnipeg and Portage la Prairie, a distance of 56 miles, this year. This will eventually be extended to Moose Jaw, a distance of 400 miles.

Wm. O'Brien and a syndicate of eastern promoters will, this summer, construct a line of railway which will open up the coal fields of the Yellow Head Pass Coal and Coke Co., west of Edmonton.

The I.C.R. is calling for tenders for the construction of a line of railway between Nelson and Chatham, N.B., eight miles. Tenders are also being called for the construction of a new branch railway between Georges River and Sydney Mines, C.B., a distance of nine miles.

A new company is being formed to control the Moncton and Buctouche Railway, and the names has been changed to the Buctouche Transportation Co. This company has already applied for a Dominion charter to extend the road to Richibucto and to carry on a service between the mainland and Prince Edward Island.

Now that the contract between the British Columbia government and the Canadian Northern has been completed, ready for presentation to the legislature, the announcement is made that grading will commence very shortly. It is the intention to rush work on this line so as to have it completed to Vancouver in the least possible time, and it will mean considerable business for all lines. With the construction of the G.T.P. in the north and work proceeding on the coast sections of the V.V. & E., there is

much activity in railway building in British Columbia.

The promoters of a new radial railway to run between Toronto and Orillia are applying to the Ontario Legislature for incorporation. The name of the concern is the Monarch Company. The proposed line parallels the Metropolitan as far as Aurora, where it turns, passing through Holland Landing, Bradford, Deerhurst, Churchill, Stroud and Allandale. A number of branches are proposed, one to western shore of Lake Simcoe in the summer, and another to Markham. The capital is placed at \$1,000,000 with bonds to the amount of \$2,500,000. The incorporators are: W. H. Price, Chas. M. Garbey, Jas. F. Coughlin, N. R. Lindsay and Steffan F. Adalia, the latter representing French capital.

Planing Mill News.

McDiarmid & Clark will erect a large sash and door factory at Brandon.

A. Beaumont's sawmill, near Augustin, Que., was destroyed by fire recently.

The planing mill at Huntsville, Ont., which was damaged by fire will be rebuilt at once.

The St. Anthony Lumber Co., Whitney, Ont., will erect a large furniture factory at that place.

The Bay Chaleur Lumber Co., Campbellton, N.B., will erect a new mill at Mission Point, to replace the structure burned last season.

General Manufacturing News.

The Acme Brick Co., established last year at Edmonton, finds its output increasing so rapidly that extensions are now under way in preparation for the coming building season.

The Great West Saddlery Co., Winnipeg, is running almost night and day in order to keep up with western Canadian demands. E. F. Hutchings, president of the company, stated that as soon as the spring opens up his firm would erect an additional factory across the street from its present location. The structure will cost in the neighborhood of \$75,000. The company will also build a horse collar factory at Calgary, Alta., which will cost about \$5,000, and will as well make additions to its wholesale warehouse at Calgary. Mr. Hutchings says that the whole of the Winnipeg plant will be run night and day during the coming year.

Building Operations.

The armory at Regina will be erected at a cost of \$100,000.

A \$76,000 station will be built by the C.P.R. at Woodstock, N.B.

The Dominion Chair Co., will rebuild their factory at Bass River, N.B.

Horn Bros., Lindsay, will erect a large addition to their woollen mills.

Barker and Johnson, of Edmonton, will erect a new flour mill at Lloydminster, Sask.

Townseley & Son, Minneapolis, have secured a site at Brandon for a factory building.

The Northern Foundry and Machine Co., Winnipeg, will erect a \$10,000 pipe foundry.

Work will be commenced at once on the enlargement of the C.P.R. hotel at Vancouver.

The Toronto Bedding Co. will build a three-storey addition to their factory at Toronto to cost \$21,000.

T. Pringle & Sons, Montreal, have awarded the general contract for the erection of a plant for the Shawinigan Cotton Co., to C. E. Deakin, Montreal.

The Canadian Asbestos Mfg. Co., a large American concern, is building a factory at Lachine for the purpose of manufacturing fireproof asbestos materials.

Superintendent Bishop, of Toronto's Board of Education, has been asked to prepare plans for the new Technical school there, of which the estimated cost is \$500,000.

The Peter Whalen property at Ottawa, has been purchased by the Hugh Carson, Ltd., as a site for the company's new factory, which it is stated will be six storeys in height. Work will be started at once.

As a result of a visit recently paid to East Kootenay, B.C., by Eduardo Rioulet, an eminent financier of France, who is president of the Canadian Metal Co., which operates the Blue Bell mine at Rioulet, B.C., an establishment for the reduction of zinc ores into zinc oxide, a property similar to white lead, used in the manufacture of paint may be built at Rioulet.

New Companies.

Port Arthur Wagon Co., Port Arthur; capital, \$750,000; to manufacture conveyances, machines and implements. Incorporators, J. R. L. Starr, J. H. Spence and M. C. Cameron, Toronto.

The Fletcher Pulp & Lumber Co., Sherbrooke; capital, \$300,000; to make lumber, wood products and pulp and paper. Incorporators, C. H. Fletcher, R. A. Ewing and R. H. Fletcher, Sherbrooke.

The Charles A. Marsh Co., Montreal; capital, \$100,000; to operate cotton, woollen and textile fabrics of every kind. Incorporators, R. O. McMurtry, F. G. Bush and H. W. Jackson, Montreal.

The Metal-Bound Box Co., Montreal; capital, \$700,000; to manufacture and deal in all kinds of boxes and furniture, etc. Incorporators, R. C. McMichael, R. O. McMurtry, W. R. Shanks, Montreal.

Sawyer-Massey Co., Hamilton; capital \$7,000,000; to make steam, gasolene and oil engines, locomotives, agricultural machinery, wagons, etc. Incorporators, J. S. Lovell, Wm. Bain and Robt. Gowans, Toronto.

The Wrought Iron Range Co., Toronto; capital, \$100,000; to manufacture and deal in all kinds of wrought iron stoves and ranges. Incorporators, J. C. Holtby, A. W. Caldwell and Thos. Reid, Toronto.

Rice, Green & Co., Toronto; capital, \$40,000; to manufacture and deal in electrical supplies, fittings and machinery for the supply of light, heat and power. Incorporators, A. R. Rice, G. W. Close, and P. Solliague, Toronto.

The Regal Motor Car Co., Walkerville; capital \$50,000; to manufacture and deal in automobiles, cycles, bicycles, motors, and carriages and conveyances of all kinds. Incorporators, J. E. Lambert, F. Haines, C. R. Lambert, Detroit.

The B.C. Gazette gives notice of the incorporation of the following companies: B.C. Ornamental Iron & Fence Co., capital \$10,000; Fraser River Brick & Tile Company, capital \$50,000; and Vancouver Gypsum Co., capital \$100,000.

The Central Canada Power Co., Montreal; capital, \$5,000,000; to construct electric machinery, appliances, devices, etc., and to operate telegraph and telephone lines. Incorporators, J. C. Hickson, S. B. Hammond, V. M. Drury, Montreal.

The Canadian Dart Co., Montreal, have been incorporated with capital of \$50,000 to build, construct and equip public and private works, sawmills, stone quarries, etc. The incorporators are: W. Dart, F. H. Jefferson, and W. H. Brunning, Montreal.

CANADIAN MACHINERY

Prince Rupert Coal Fields, Ltd., Montreal: capital, \$5,000,000, to carry on colliery trade; to mine coal, and smelt and treat iron, steel, tin and other metals; and to refine oil and make powder, etc. Incorporators, M. Alexander, D. B. Smith and T. D. Fillan, Montreal.

Hillcrest Collieries, Ltd., Montreal: capital, \$3,000,000; to mine coal, coke, supply natural gas and oil, and to manufacture machinery, implements, etc., used in connection with mining, timber or lumber operations. Incorporators, J. M. Mackie, A. H. B. MacKenzie, C. Meredith, Montreal.

Superior Rolling Mills Co., Fort William: capital, \$500,000; to mine, mill, smelt and refine, gold, silver, copper, coal, iron and other minerals, to make wire nails, steel rails, iron bars, and refine oil, supply natural gas, etc. Incorporators, G. H. A. Montgomery, R. O. McMurtry and F. G. Bush, Montreal.

Dominion Corrugated Steel Pipe Co., St. Johns, Que.: capital, \$20,000; to make steel pipes, culverts, metal sidings, agricultural machinery and to carry on a foundry business and operate rolling mills. Incorporators, C. H. Richardson, St. Johns; H. Proctor, Wm. Wakefield and A. C. Sellar, Sandusky, Mich.; and Geo. Donaldson, Topeka, Kan.

A bill to incorporate the Ottawa and Montreal Power Transmission Co., will be presented to the House of Commons. Authority will be sought to transmit power in the counties of Wright and Pontiac, etc., and to Montreal. Capitalization, \$500,000. Incorporators, Cameron Edwards, J. B. Fraser, R. G. Edwards and R. Blackburn, all of Ottawa.

Trade Notes.

The Canadian Inspection Co., have removed their Toronto offices from 37 Melinda St., to the Stair Bldg. cor. Adelaide and Bay Sts.

The Johns-Mannville Co., manufacturers of asbestos packing and other mill supplies, have opened an agency in Vancouver, their representative being Mr. Tackabery.

Smart-Turner Machine Co., Hamilton, have supplied pumps recently to H. W. Ansley, Port Dover; C. A. Larken Lumber Co., Toronto; S. F. Bowser Co., Toronto; Canadian Paper Co., Windsor Mills; J. C. Mundell Co., Elora; Shea's Theatre, Toronto; Kinkleith Paper Co., St. Catharines; Zimmerman Mfg. Co., Hamilton; Toronto Ferry Co., Toronto; Harris Abattoir Co., Toronto; Page Hersay Co., Toronto; W. Harris Co., Toronto; Delora Mining & Reduction Co., Delora; Allan Sheemaker, Berlin; Hamilton Steel & Iron Co., Hamilton, and McQuay Tanning Co., Owen Sound. They have also received an order for a 5-ton traveling crane from the Manitoba Wind Mill & Pump Co., Brandon.

International Asbestos Association.

The International Asbestos Association was recently organized at a meeting held in New York. Its membership is composed of representatives of American and Canadian mine owners and manufacturers. The interests at the meeting represented between 80 per cent. and 90 per cent. of the asbestos business in the United States and Canada. Included in the association are the largest producers and users of asbestos in the United States and Canada, among them the Amalgamated Asbestos Corporation, Limited, Keasbey & Mattison Co., Philip Carey Mfg. Co., Asbestos Protected Metal Co., Franklin Mfg. Co., H. W. Johns-Manville Co., Sall Mt. Asbestos Mfg. Co., Ling Asbestos Co., and the United States Asbestos Co. The aggregate capitalization of the concerns who are so far represented is over

\$40,000,000. The following were elected officers of the association: T. F. Manville, president; R. V. Mattison, Jr., vice-president; R. P. Doucet, secretary.

It is announced that the purposes of the association are the general exploitation of the uses of asbestos, particularly in the field of fireproof construction, co-operation between consumer and producer, cultivation of new markets, and development of processes whereby the wastes in the industry may be rendered commercially valuable. The association will establish a bureau that will be devoted to the aforementioned purposes.

One of the important factors in the association is the so-called Canadian "Asbestos Trust"—the Amalgamated Asbestos Corporation,—a combination of several of the most important Quebec asbestos properties located at Black Lake and Thetford, and which controls 80 per cent. of the output of these districts. The greater part of the world's supply of asbestos comes from the Black Lake and Thetford districts. Among the directors of the corporation are Hugh A. Allan, of the Allan Line Steamship Co., ex-assistant Attorney-general James M. Beck, Harry A. Berwind, of the Berwind-White Coal Mining Co., Geo. D. Crabbs, of the Philip Carey Mfg. Co., E. B. Greenshields, of Montreal, Robert Mackay, of the Canadian Pacific Railway, H. H. Melville, of the Canadian-Northern-Quebec Railway, R. V. Mattison, president of the Keasbey & Mattison Co., and H. E. Mitchell, of the Philadelphia banking firm of Cramp, Mitchell & Shober.

Asbestos is produced in Canada, Russia, the United States, Cape Colony, and the island of Cyprus. It is stated that the Canadian asbestos supply is practically inexhaustible and that it is the chief factor in the control of the asbestos industry of the United States and, in a marked degree, of the world.

Thompson Bros., Liverpool, N.S.

Thompson Bros., machinist, Liverpool, N.S., have erected large additions to their plant. Their new buildings are situated on the waterfront at Liverpool with both water and rail shipping facilities. The machine shop consists of a two-storey reinforced concrete structure, 61 feet long by 50 feet wide. The equipment consists of a ten ton planer and one of smaller capacity, five lathes, one shaper, one drill, one milling machine and one grinder. All these are new and of latest design to use high speed steels.

The output consists of sawmill machinery and pulp machinery, a large contract for pulp machinery for Clyde River being under construction. Ship work is a specialty such as steering gear, pumps, windlasses, capstans and steam winches.

The firm consists of W. J. Thompson and H. Thompson. They began in a small way in 1897 and have succeeded in building up a fairly good business.—D.W.

Disston Company Expanding.

Henry Disston & Sons, Philadelphia, Pa., have recently opened branch houses in Seattle, Portland, and Vancouver, to better facilitate the filling of orders and take care of the constantly increasing trade. These branches will devote their attention exclusively to the mill goods business, such as inserted and solid tooth circular saws, bandsaws, crosscut saws, cylinder saws, mill saws, stove saws, saw tools, machine knives, files, steel, etc. The Disston factory at Toronto, established only two or three years ago, having become too small a new site was secured on Frazer Avenue and the Grand Trunk Railway, Toronto, upon which two new buildings have been erected; one of two stories,

OPAL GLASS TILING
FOR WALLS OF
MACHINERY AND POWER HOUSES
Most approved material.
TORONTO PLATE GLASS IMPORTING CO'Y
PLATE AND WINDOW GLASS
135 to 143 Victoria St., - Toronto

Chief Draftsman AND ENGINEER
will personally—practically instruct a few ambitious, deserving, bright men on practical, actual, up-to-date **Drafting Room Work** at home, prepare and qualify them as first-class experienced **Draftsmen and Designers** for a salary paying \$100 to \$150 per month. Instructions until competent, and placed in position **free**. Also complete high grade drawing outfit, with German Silver set of **instruments worth \$12.95 free this month**. Don't answer this unless you are ambitiously seeking success and willing to work for results.
Address **CHIEF DRAFTSMAN, Div. 22 ENGINEERS EQUIPMENT CO. (INC.) CHICAGO, ILL.**

THE BEYER WATCHMAN'S PORTABLE CLOCK

IS TAMPER PROOF and thoroughly reliable
Shall we send Particulars?
G. C. BREDIN, Sales Agent
252 Dundas St. London, Canada
Record Dials furnished for all machines.

Do Your Tumbling

in a Globe improved Tilting Tumbler and get finest results, quickest and cheapest. It is made in six sizes for all purposes for wet or dry work.
"GLOBE"
Dies and Stampings.
Special Manufacturing Contract Work.
If you want to get an interesting little magazine free, ask for "THE SIL- ENT PARTNER."
THE GLOBE MACHINE & STAMPING CO.
809 Hamilton Street, Cleveland, O.
Canadian Agent:
H. W. PETRIE, Front St. W., Toronto, Canada

YOUNG machinist or technical graduate wanted to travel. Must be good talker and resourceful. No previous traveling experience necessary. Splendid opportunity for ambitious man to work into a good position. Apply
BOX 101
Canadian Machinery
Toronto

250 x 60 ft., the other being one story, 170 x 55 feet, into which they recently removed. These buildings have been equipped with the latest improved machinery for the manufacturing of mill goods such as circular saws, band, gang and crosscut saws. In the new plant the machinery will be motor driven in groups, the buildings heated with an improved hot air apparatus, driven by a fan and so arranged that the rooms can be kept cool in summer as well as heated in winter.

1910 Calendar.

F. Reddaway, 56 St. Francois Xavier, Montreal, manufacturers of Camel Brand cotton belting distributed a large office calendar printed in two colors. An installation of a belt outside is a feature of the calendar.

Vancouver.

Large power propositions are being proceeded with in the vicinity of Vancouver and Victoria. The B.C. Electric Railway Co., which only lately put into operation its most recently installed unit at its Lake Buntzen plant on the mainland, is now developing the power on the Jordan River, to give more electrical energy for industrial and lighting purposes in Victoria. The Vancouver Island Power Co. is a subsidiary organization and on Jan. 29th it let the contract for a 10,000 h.p. Doble impulse waterwheel, directly connected to a 4,000 k.w. Allis-Chalmers-Bullock generator, running at 4,000 revolutions per minute, to the John McDougall Caledonian Iron Works Co. The contract also includes an exciting generator directly connected to a water wheel. The installation is to be completed by October 1st, 1910. The plant at Jordan river will be located on salt water, a pipe line 9,000 feet long being necessary.

Two-thirds of the electrical portion of the machinery for this plant is to be supplied by the Canadian General Electric Co. It includes step up and step down transformers, switchboards, lightning arresters, etc.

On the mainland, the Western Canada Power Co. is vigorously pushing development on Stave river, 35 miles east of Vancouver, just north of the main line of the C.P.R. After Montreal capitalists sold out the Mexican Light and Power Co. in Mexico to English capitalists, they took up this proposition, which was formerly handled under the name of the Stave Lake Power Co. R. F. Hayward, who was with the Mexican company, is the engineer in charge. The plant to be installed immediately on Stave river will have a capacity equal to that of the B.C. Electricity Railway Co. at Lake Buntzen, the one beginning where the other is leaving off. The Canadian General Electric Co., of Toronto, will supply two generators of 16,000 k.w. normal capacity and a 36,000 k.w. transformer, which when in operation will produce about 30,000 h.p. The waterwheels will be supplied by the Escher-Wyss Co., of Switzerland, and the high tension insulators by the Thomas Insulator Co. Other contracts are yet to be let for the steel towers and poles, switchboards, etc.

This company is making no bid for business as yet, but it anticipates little trouble in securing a market for its power once it is available. The present supply of power in New Westminster, Vancouver and surrounding districts is not any more than the demand, so there should be room for another company.

In addition to these projects, the Powell River Paper Co. has started operations for the development of 25,000 h.p. on Powell river. It is proposed to manufacture both paper and pulp there, and it will take two years to put in the requisite machinery. Powell river is located about 100 miles north of Vancouver on the mainland of British Columbia.

INFORMATION

about every conceivable subject finds its way into the newspapers. The function of THE CANADIAN PRESS CLIPPING BUREAU is to collect ALL the items of information appearing in Canadian newspapers about any subject YOU are interested in. Our service is thorough. We don't miss an item. If you want ALL THE CURRENT INFORMATION about a pet subject, we can supply it at the lowest cost. By using our service you can KEEP POSTED on any subject.

WRITE FOR OUR FREE BOOKLET

THE CANADIAN PRESS CLIPPING BUREAU

232 McGill Street, Montreal

10 Front Street E., Toronto

ALUMINIUM



You can now get your Aluminium requirements promptly attended to by our clients, The British Aluminium Co., Limited, of

"The 20th Century Metal"

Lightest and most adaptable of the industrial metals. Fills a hundred purposes where the ordinary metals fail. Saves its cost over and over again by its lightness and easy working qualities.

INGOTS, BARS, SHEETS, RODS, ANGLES, ALLOYS, NOTCHED BARS, CORNICES, WIRE, CHANNELS, ETC.

London, the largest producers in the United Kingdom.

Sole Agents for Canada: Parke & Leith, 205 Yonge Street (Bank of Toronto Building) - - - Toronto.

To-day get Bulletin "D" on the varied uses of ALUMINIUM (Parke & Leith)

JESSOP'S BEST TOOL STEEL "ARK" High-Speed Steel

THE FAVORITE BRANDS WITH USERS OF GOOD STEEL. A LARGE ASSORTMENT OF SIZES IN STOCK. JESSOP'S HIGH-GRADE FILES AND RASPS.

80 Bay, St., Toronto, Ontario
Chas. L. Bailey, Agent.

Jas. Robertson Co., Ltd.
Montreal, Quebec

Reid-Newfoundland Company
St. John's, Newfoundland.

Jas. Robertson Co., Ltd.,
St. John, New Brunswick

WM. JESSOP & SONS, Limited, Manufactory, SHEFFIELD, ENGLAND.

We want your orders for

SPECIAL TAPS

Price, delivery, and quality will please you.

A. B. Jardine & Co., Hespeler, Ont

CATALOGUES.

HYDRAULIC VALVES AND FITTINGS—Is the title of a 120 page illustrated catalogue just issued by the Watson-Stillman Co., 80 Church St., New York. Its pages list a great many types and combinations of hydraulic valves and fittings. Almost every page contains some hint or advice as to the best piping arrangements, what types or combinations of valves are best suited to certain work, how the valves arrangement may operate a number of cylinders or machines automatically, etc. Any engineer will find this book handy when figuring on new hydraulic installations or making changes on old ones. This book will be sent free to any one requesting catalogue No. 78.

SAFETY CUTTER HEAD—J. A. Fay & Egan Co., 362-382 w. Front St., Cincinnati, Ohio, have issued a new catalogue No. 31 which fully describes and illustrates their new Safety Circular Cutter-Head. This machine is described in this issue. Copies of the catalogue may be obtained by writing the J. A. Fay & Egan Co.

VERTICAL BORING MILLS.—Gisholt Machine Company, Madison, Wis., Bulletin. Describes the friction headstock and the lever control of the Gisholt vertical boring mills. The special feature of this device is that the driving mechanism of the table is entirely self-contained in a separate casing, which enables the whole drive to be removed in a short space of time if necessary.

TURBINES.—Kerr Turbine Co., Wellsville, N. Y., have just issued two new bulletins, No. 9, "Turbo-Blower Units," and No. 10, "Steam Turbine Generators, Steam Turbine Centrifugal Pumps." The first bulletin illustrates practical outfits for forced and induced draft, gas works service and for furnishing blast for cupolas. The other bulletin includes generating sets for electric power and lighting, and pumping units for boiler feeding, fire service, water supply, circulating condenser water, draining pumps, and for other service where water must be delivered at moderate or high pressure or against considerable head. Both of these bulletins contain interesting descriptive matter about the construction and operation of Kerr Steam Turbines. The comparisons between turbine and reciprocating engines can profitably be read by all who are in charge of or operate steam power plants. Bulletins will be mailed upon request.

D. C. MOTORS—Phoenix Dynamo Mfg. Co., Bradford, Eng., have issued a bulletin of 49 pages on coated paper giving illustrated descriptions of constant and variable speed motors. These are protected, enclosed, ventilated or rainproof type. Full information in regard to size, price, etc., is included in the catalogue. Catalogue

ELEVATOR CONTROLLERS—In a 128 page booklet just issued by the Cutler-Hammer Mfg. Co., of Milwaukee, the subject of the control of electrically operated elevators is very fully covered. The first section of the booklet contains illustrated descriptions of full magnet and semi-magnet direct current controllers for high speed, moderate speed and slow speed passenger and freight elevators, together with descriptions of sidewalk lift controllers, reversible and non-reversible controllers for belt driven freight elevators, and mechanically operated controllers for use where current conditions are extremely variable. Illustrations and descriptions are also given of such necessary elevator accessories as brake magnets, car switches, limit switches, etc. The second section of the booklet is devoted to similar controllers for use on alternating current circuits and the concluding pages contain tables of useful information, including suggestions regarding the proper type of motor to use in each case.

FURNACES—A neatly printed booklet issued by the Murphy Iron Works, Detroit, Mich., il-

lustrates a large number of instalations and applications of the Murphy furnace. This is issued as a supplement to their complete descriptive catalogue.

BOOK REVIEWS.

ADVERTISING AND ITS SERVICE—In a pamphlet entitled "Advertising and Its Service," the Geo. H. Gibson Co., has reprinted from the New York Evening Post, an article discussing the economic theory of advertising, especially as regards the engineering and mechanical industries. It is shown that, contrary to current academic opinion, properly directed advertising reduces the cost of distribution of goods by providing the salesmen with a greater number of selling opportunities in a given territory and in a given time. It performs the preliminary, but necessary work of informing and educating the prospective user as to the nature, possibilities and profitableness of improved machinery, thereby hastening its adoption. Greater sales, brought about through advertising, usually make possible cheaper production, thereby benefiting the community as a whole, while competitive advertising, which seems to be the especial bugaboo of socialistic writers, is also a benefit inasmuch as it stimulates to improvements in the design of apparatus, and advertising is necessary in order that such improvements may meet with a prompt and adequate reward. A secondary benefit is derived from the fact that a consistent policy of advertising lessens the capital risk when new enterprises are undertaken and insures permanency to a business. In other words, advertising does not become an added burden on the consumer. Copies of this pamphlet may be had from the Geo. H. Gibson Co., Advertising Engineers, Tribune Building, New York City.

METAL STATISTICS.—The American Metal Market Co., New York, have published a little book, 1910 Metal Statistics, which is a mine of information regarding metals, their prices, production, etc., during the past decade. The present edition embraces a number of new features and the old ones have been more or less improved. The iron and steel section has been enlarged, and improvement is noted in the tables devoted to iron ore, pig iron and iron and steel products generally. The other metals are dealt with very fully, but in a concise form. The book of statistics is worthy a prominent place in the reference file.

GAS, GASOLINE AND OIL ENGINES.—By Gardner D. Hiscox, M.E. Size, 6 x 9 1/2 in.; pages, 484; illustrations, 410. Bound in cloth. Price, \$2.50 net. Published by the Norman W. Henley Publishing Company, 132 Nassau Street, New York City.

The eighteenth edition of this practical work treats of the entire field of the explosive motor and its applications. This new edition has been revised and enlarged to bring it up to date by adding material that represents the latest standards of construction and operation of this type of motor and the production and uses of producer, suction blast furnace and coke oven gases. These gases are now coming to the front as sources of the economical development of power on a large scale and are being used more and more extensively each succeeding year.

Crude petroleum, which has an increasing sphere of usefulness as the cheapest power fuel where the erection of gas plants is not convenient, comes in for a share of attention and the methods of converting it into power fuel are illustrated and described.

The rules of the National Board of Fire Underwriters regarding the installation and management of gasoline motors and the location and management of producer gas plants, with the

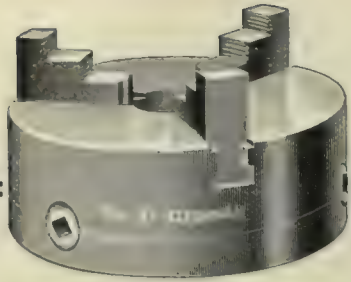

"CUSHMAN" CHUCKS

Our 1910 Catalogue of Lathe and Drill Chucks is now ready for distribution. The book gives full description, prices, etc., of the many styles and sizes we manufacture.

We are pleased to send it free to anyone interested.

The Cushman Chuck Co.

Hartford, Conn., U.S.A.

Established 1892

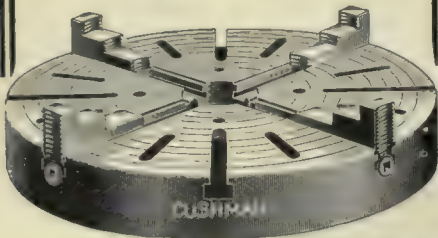

We have confidence

—such unbounded confidence in our

IMPERIAL CHUCK

and are so satisfied that no test is too severe for it, that to introduce it to your shop we will send you one on

30 days' Free Trial

Test it any way you can think of, use it every day, and if it does not do all you ask of it, send it back at our expense.

Anything fairer? Then send to-day

KER & GOODWIN

BRANTFORD, CANADA

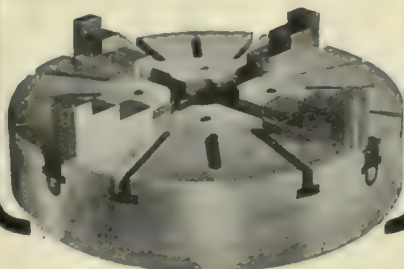

special rules of the New York Board for gas-oline engines installed in that city are given in full.

In the application of gas and gasoline engines to marine use a number of changes have been made during the last two years and are included in the book. Some of these have been in the nature of improved patterns of existing types, while others were entirely new designs. For farm and suburban use the internal combustion engine has almost entirely superseded the wind-mill, and it is being employed very extensively to drive portable machinery in place of the electric motor.

A list of patents issued by the United States Patent Office covering gas, gasoline and oil engines and their accessories from 1875 to October, 1909, is also included in the book.

FUEL TESTS WITH HOUSE-HEATING BOILERS—By J. M. Snodgrass, is issued by the Engineering Experiment Station of the University of Illinois as Bulletin No. 31. It reports 130 tests of anthracite, Pocahontas coal, coke and Illinois coal made in connection with two types of house-heating boilers. Copies may be obtained gratis upon application to W. F. M. Goss, Director of the Engineering Experiment Station, University of Illinois, Urbana, Illinois.

THE OCCLUDED GASES IN COAL—By S. W. Parr and Perry Barker, issued as Bulletin 32 of the Engineering Experiment Station of the University of Illinois, is essentially a study of the behavior of coal towards the atmosphere. The avidity of coal for oxygen is made evident, and the results of the entire work bear directly upon the matter of weathering and of spontaneous combustion. Copies of bulletin No. 32 may be obtained gratis upon application to W. F. M. Goss, Director of the Engineering Experiment Station, University of Illinois, Urbana, Illinois.

TESTS OF TUNGSTEN LAMPS—By T. H. Amrine and A. Guell, issued as Bulletin No. 33 of the Engineering Experiment Station of the University of Illinois. It reports a series of tests upon tungsten lamps of the 25-watt size, with filaments made by the paste, colloid and deposition processes. Copies of Bulletin No. 33 may be obtained gratis upon application to W. F. M. Goss, Director of the Engineering Experiment Station, University of Illinois, Urbana, Illinois.

The Skinner Chuck Co., New Britain, Conn., gave a dinner to their employes on Dec. 28. The menu cards were very artistic and contained a litho of D. N. Camp, president. Sec'y E. J.

ERNEST SCOTT

91 BLEURY ST., - MONTREAL

Machinist and Tool-maker

Dies for sheet metal work. Stampings and light manufacturing. Special machinery designed and made to order.

NOTICE TO SUBSCRIBERS

Subscribers will confer a favor on us by notifying us in case they are not receiving their paper regularly, or if they find they have missed one or more issues. We send out thousands of copies each month, and it is only natural to suppose that a few copies will go astray in the mails, even though every precaution is taken by us to avoid this.

We should also be notified at once of any change of address, giving both old and new addresses.

The Art of Welding Metals

The use of the *Oxy-acetylene blow-pipe* in welding has greatly extended the field in this class of work.

Simple or complicated fractures and breaks in all kinds of machinery may be repaired and made almost equal to new in strength and appearance; the broken edges of iron, steel, aluminum and other metals are melted together with the addition of more metal under a temperature of 6,000 to 7,000 degrees Fahrenheit.

This plan is much superior to brazing or riveting and may be used for an infinite variety of new and repair work hitherto done by less efficient methods.

We have installed a plant for the purpose of welding by this process, and shall be glad to send particulars and quote prices.

Enquiries and correspondence solicited.

CHAS. POTTER,
85 YONGE ST., TORONTO



THIS SENSITIVE BENCH DRILL

WILL PROVE A MONEY-SAVER IN YOUR SHOP

It is the handiest bench drill on the market for rapid drilling up to 5-16 of an inch. The spindle has two speeds and is driven by a one-inch flat belt. It is entirely relieved of belt strain; is counterbalanced by a weight inside of the frame, and is provided with the means for taking up wear.

This machine will last a long time and stand a lot of wear, as only the highest grade material is used in its construction.

A Postal will bring Prices and Circular.

D. MCKENZIE, 19 Nottingham Street, GUELPH, Ont.

KELLOGG & CO.
MACHINERY MERCHANTS

196 KING STREET WEST, TORONTO

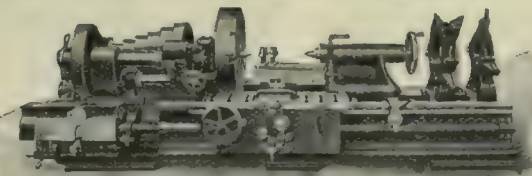

CANADIAN AGENTS:

- The G. A. Gray Co. Planers.
- Schumacher & Boye. Lathes.
- The Cincinnati Lathe & Tool Co. 16" Lathes.
- The King Machine Tool Co. Boring Mills.
- The Oesterlein Milling Machine Co. Milling Machines and Cutter Grinders.
- The Western Machine Tool Works. Radial Drills.
- The Barnes Drill Co. 20" Drills, 12"-22" Gap Lathes.
- The Cook Motor Co. Stationary Gas and Gasoline Engines.
- Francis Reed & Co. Sensitive Drills.

Inquiries for new or special machinery will receive our prompt attention.

CANADIAN MACHINERY

PACKING FOR VALVES.

Frothingham & Workman, Montreal, have been appointed agents for the Federal Metallic Packing Company, Boston, who manufacture a number of packing lines. The Pactite brand, made from the finest alloy of Antifriction metal, is the most serviceable, and is used for packing of all kinds of stationary joints, valves, etc. It is flexible, compressible and lubricated, stands any degree of temperature or pressure and does not injure a rod of any kind. The method of fibering metal to be woven into a packing was originated by the Federal Metallic Packing Company. The construction of the various packings of the company gives the impression that all are alike, and yet this is only true in appearance as there are many different cores and inside binders which are always effective in the stuffing boxes for which they are intended.

MACHINISTS, ATTENTION!

MACHINIST'S TOOL-CASE FREE to one man in every shop. Address, with stamp, O. BURCH, Grand Rapids, Mich. (3)

BUSINESS OPPORTUNITY.

A PARTY holding a large interest in a well-established prosperous machinery manufacturing company on the Pacific coast, wishes to dispose of part of his holdings to meet personal obligations. Can arrange if necessary for purchaser with proper qualifications to take an active part in the management. This is a splendid opportunity and investment for anyone wishing to get a start in a good, steady, legitimate, profitable business, in a young, growing country. Applicants who mean business, must have at least \$20,000. are invited to investigate. Write Box 102, CANADIAN MACHINERY, Toronto. (4)

STEAM PLANTS IN SILVER MINES.

The extent of mining development going on in the new silver camps of northern Ontario is set forth in a table just published, showing the new steam plants in operation, their locality and capacity. The list as published is as follows:—

	Compressor Capacity	Boilers free air H.P.
Elk Lake District.		
Ribble Property	95	410
Diabase Mining Co.	30	—
Gavin Hamilton	80	410
Bix Six	100	410
Cummings	100	330
Elk Lake Discovery	110	585
Moose Horn	120	330
Elk Lake Cobalt	100	585
Toledo Silver	60	330
Otisse	160	825
North American	30	
Silver Lake	20	

Otisse Currie	90	825
Big Six	80	823
Blackburn	120	660
Bonsail	100	330
Bartlett	160	1160
Boyd Gordon	100	585

While the list is the most complete yet published, it does not include steam plants on the Reeve-Dobie and Mann at Gowganda, and the Silver Tunnel at Silver Lake. At Maple Mountain the White Syndicate have a plant in operation. In the Anima-Nipissing belt, west of Latchford, a Buffalo syndicate has a steam plant at work. Several mines in South Lorain, including the Keeley and Wetlaufer, have steam plants and compressors.

The impressive fact is that hundreds of thousands of dollars are being invested in mining development, that thousands of men are finding steady work at good wages, and that men who are spending their time and money have found that their industry will be rewarded.

BRASS CASTINGS

OF ALL SIZES AND KINDS

LUMEN BEARING COMPANY

BUFFALO TORONTO

LUFKIN

MACHINE DIVIDED STEEL RULES with Readable Graduations

Every 64th numbered. Easy and sure in reading. Best of material. Finest of workmanship. Accuracy guaranteed.

Send for catalogue.

Sold by all prominent hardware and supply dealers

THE LUFKIN RULE CO. OF CANADA, Ltd.
WINDSOR, ONT.



The Modern Machinist

By J. T. Usher

A comprehensive treatise written in a practical, up-to-date manner describing the most approved methods of modern machine shop practice, including processes and appliances used for cutting, shaping, fitting, erecting and finishing metal work on the different machines. It contains information of Great Value to all Machinists, Apprentices, Etc.

257 New Engravings.

322 Pages.

Price \$2.50 Postpaid.

MacLean Publishing Company,
Technical Book Dept. 10 Front Street East, Toronto

TELEGRAPHIC ADDRESS
"HALLTYNE"

WORKS
PHONE MAIN 256

THE HALL ENGINEERING WORKS

14 TO 16 JURORS STREET, MONTREAL

ENGINEERS, BOILERMAKERS, BRASS & IRON FOUNDERS,
COPPER SMITHS & BLACKSMITHS, SHIP REPAIRS A SPECIALTY

Agents for J. & E. Hall's Refrigerating Machinery.
Atlas Preservative Co. & United Asbestos Co.
W. H. Allen, Son & Co., Ltd.
ENGLAND

THOMAS HALL

Phone West 1737

Late Supt. Engineer Messrs. Elder
Dempster & Co. & Can. Pac. Rly. Co., London

A Speed Variation of 18 to 1 on Motor Driven Planer

The Lancashire Dynamo and Motor Co. Have Recently Introduced an Electrical Drive, giving Remarkable Speed Variation of 18 to 1—The Accuracy Obtainable in Reversal by this System is fully Described and Illustrated.

The electrical driving of planing machines is a matter that has had a good deal of attention in an endeavor to eliminate the defects of mechanical reversing gear.

The objects to be obtained are: (1) Simplicity and reliability; (2) Some method of recovering the energy imparted to the table, particularly during the return stroke; (3) A large range of speed; (4) A method applicable to both direct and alternating systems.

A Unique Method.

In the following system known as the "Lancashire" system, these results are obtained in a very high degree, and the system provides an extremely flexible drive for this class of machine. The shaft that operates either the screw or the rack of the planer is connected direct to a motor, the motor itself reversing at the end of each stroke. This motor has its direction of rotation controlled by a small high-speed motor generator set the motor of which is driven off the mains, by either alternating or direct current.

The armature circuit of the planer motor is not broken at all, the reversals being effected by reversing the polarity of the generator of the motor generator set, which is done by reversing the field connections. This means that the reversing switch instead of dealing with the full current required to drive the planer only deals with a few amperes, and the switch therefore can be made very light and yet strong. The whole of the mechanism for reversing is merely a two pole two-way switch actuated by the stops on the table. The makers claim that this method of reversal eliminates the rather expensive controller renewals generally required with systems in which the armature current is reversed. A separate small switch is provided to stop and start the planer, or in the case of large tools, two are provided one on each side of the machine.

18 to 1 Speed Variation.

The range of speed is really only limited by the maximum speed at which a table can be returned. As this is usually about 180 or 200 feet per min., the usual range of speed supplied is 18-1, that is, with a planer that returns at 180 feet per minute, there are provided about 30 steps on the cutting stroke the lowest being ten ft. per min. and the highest 180. These very low

speeds are very useful in setting large jobs and in taking rough cuts off castings with scale on them.

The motor works at rather less efficiency at the lower speeds, but as the control is not by armature resistance the loss is not material. Two of the cuts show a 18 ft. x 6 ft. x 6 ft. planer which, with a total load of eleven tons, is provided with a cutting speed of from 5-180 feet per minute and a return speed of 180 feet.

Conservation of Energy.

One of the great features of the system is that the energy imparted to the

table to stop at exactly the same spot of the motor generator set, to be used again to accelerate the table quickly without drawing an excess of current from the line.

The power curve of a planer equipped with the system is shown herewith, Fig. 3, and this shows clearly the current returned to the line, and the absence of a large peak, during the accelerating period, notwithstanding the high speed that the planer was run at.

Planing to a Line.

This method of storing the energy has also the advantage that it causes the

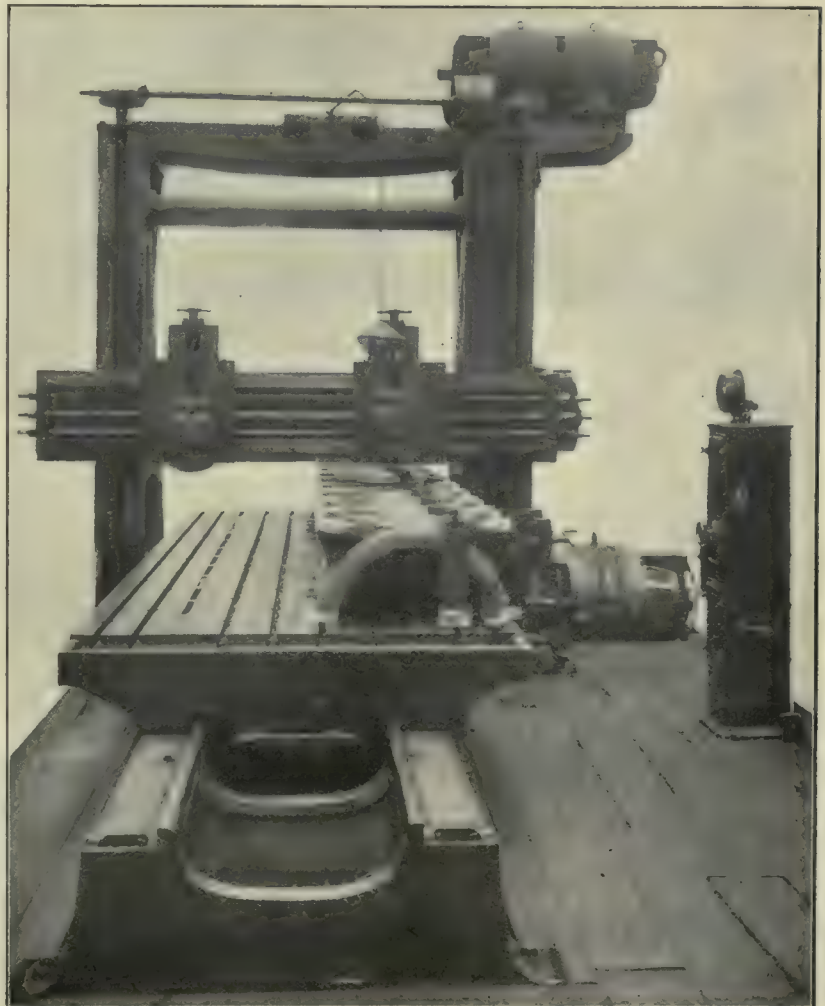

Fig. 1.—Planing Machine Equipped With Lancashire Electric Drive.

table during acceleration is not lost in heating belts, clutches or resistances, but is partly returned to the mains, (the motor acting as a generator) and is partly stored up by raising the speed

every time, owing to the fact that the braking effort is always constant, and is not dependent on any mechanical contrivance that may vary in strength through damp or heating. A photo-

graph of the cuts made in a block by two planers is here shown. Fig. 4 shows the cuts made by a modern belt driven planer, cutting at 54 feet per minute and returning at 150 feet. Fig. 5 shows the cuts made by a larger planer converted to the electrical drive when cutting at 60 feet and returning at 180 feet. In the latter case the planer table comes true to the same mark at the end of every stroke.

Adaptability.

The system is very easy to adapt to existing planers, and the smoothness of the reversal enables the speeds to be

pull up in about eight inches, even when running at 180 feet per minute, and with a table load of ten tons.

The originators and makers of this gear are the Lancashire Dynamo and Motor Co., Ltd., 152-154 Bay Street, Toronto. They do not make planing machines, but supply all the electrical gear for the drive.

DRY VERSUS WET TOOL GRINDING.

Users of tool grinders are leaning toward dry grinding for the general purposes of the machine shop, not because

necessarily be taken. Of course in works where much of the tool sharpening is done by the toolroom, experts are employed, and the wet grinding is often preferred, for obvious reasons.

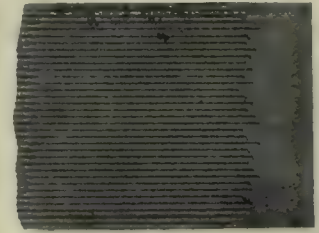

Fig. 4.—Block Planed on Planer Before Equipped With Lancashire Drive.

A series of tests made in the course of research into the characteristics of the high-speed steels developed the fact that the failure of tools made of such a steel to accomplish a good finish on

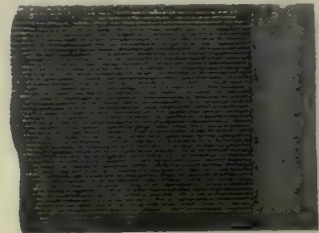

Fig. 5.—Block Planed With Lancashire Drive.

work is due to unskilful grinding. Even under a copious stream of cold water the tool becomes red at the surface. So great a degree of heat cannot be diffused rapidly enough, and inner stresses occur. The fineness of the cutting edge quickly breaks down under use. The tool loses nothing in its capacity for roughing, but it lacks the edge requisite for a finishing chip. A remedy is to

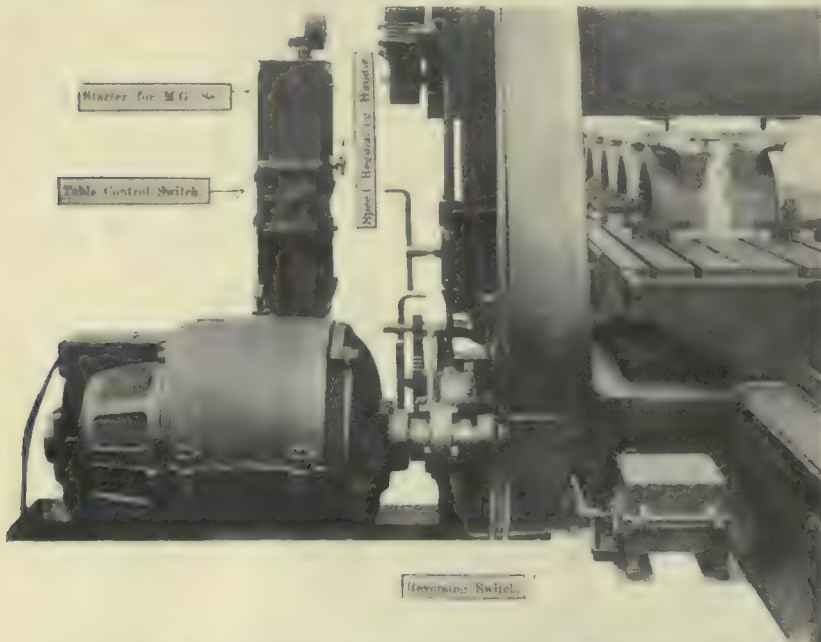

Fig. 2.—The "Lancashire" Drive, showing Table Control.

materially increased, and with the large speed variation given one can always have the machine cutting just as fast as each job will stand, as of course to alter the speed is only a matter of turning the speed regulator to the speed required. As the motion of the reversing switch is a simple to and fro motion, and the speed of the movement is immaterial, it is adaptable to any existing belt shifter.

Foolproof.

The makers state that, provided the table has stops on it, it is absolutely impossible to cause the table to run off, under any circumstances, short of breakage. If the supply of current fails, the planer runs until the energy in the moving parts is expended, but if the supply fails when the motor is just on the point of reversal, the motor still reverses. This is a very important point, as with some drives, if the power fails, the motor will not reverse, but allows the table to run off. If any of the contacts in the reversing switch failed to make contact the table will

the results are better, but because with the wet process the average workman places altogether too much reliance upon the cooling influence of the water.

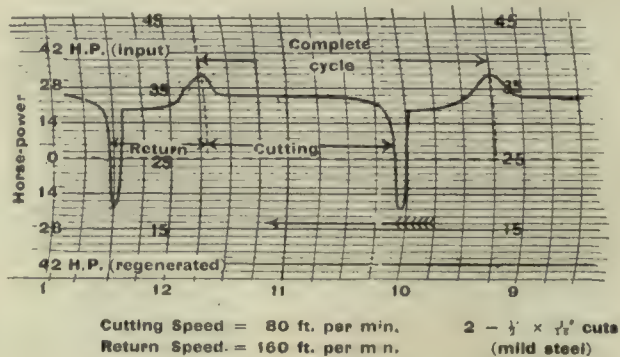

Fig. 3.—Power Curve of Electric Drive on the Lancashire System.

He presumes that the cooling agent is able to carry away the heat generated by the contact of the steel and wheel, no matter how severe that contact may be, and the ruin of the tool may result. With dry grinding greater care must

grind the tool hot. In the tests alluded to an extreme fineness of work was procured by this process, and equally good results were obtained when sufficient care was taken in grinding cold.—Iron Age.



A Group of Grand Trunk Railway Apprentices in the Montreal Shops.

How the G.T.R. has Solved the Apprenticeship Question

Canadian Railroads are in Need of Trained Mechanics; to Supply the Demand they have Successfully Devised and Carried out a System for Training Good Mechanics—This Article deals with the G.T.R. System.

With the idea of training intelligent mechanics, the Grand Trunk Railway several years ago started a class for its apprentice boys, who were eager to learn; commenced to teach subjects which at once aroused interest among the boys, bearing as it did on the every-day needs of mechanics. In a surprisingly short time, the desire for knowledge being whetted, it was found necessary to increase the scope of the teaching, as the apprentice boy of the day saw within his grasp the very highest position of responsibility in the management and operation of the road. He realized that here was an opportunity to obtain an education little short of a college course, with a minimum exertion on his part and at the same time be independent and self-supporting.

From the commencement on a small scale, the system has grown until at the present time these technical schools are spread at all important centres throughout the entire Grand Trunk System and hundreds of scholars are enrolled, whilst every large railway system of this continent boasts several graduates of the G. T. training schools as their chief mechanical engineers, and more than one of our largest industrial

concerns have graduates as their chief draughtsmen.

The subjects taught are graded to suit the student's ability and in dozens of cases boys who left school when in the second book can now do problems which would tax the powers of a High School graduate to the utmost.

The subjects taught comprise everything from simple arithmetic to higher mathematics, mechanics, machine design and mechanical drawing, and so well has the course been graded that numerous requests from mechanics' institutes and even our largest technical colleges have been received for complete sets of instruction books.

The entire cost of education at these training schools is borne by the Grand Trunk System, who furnish all the equipments and engage the instructors, who must themselves have had a thorough technical and practical training, so as to enable them to anticipate the needs of the apprentices.

The appreciation of individual promotions forms one of the strongest features in the system and serves to keep alive the keenest interest in the classes, as the boys realize that as soon as they arrive at a certain standard of excel-

lence, increased pay is their reward, and many of our foremost students of political economy, see in this system, as it is being carried out, the future supply of skilled mechanics, master mechanics, superintendents, etc., being carefully husbanded, and an effective solution to labor problem, namely, the prompt recognition of individual merit.

Night Classes in Drawing and Mechanics.

For two evenings per week during the fall and winter months he must attend mechanical drawing classes, study of practical mechanics and elementary electricity, the most competent instructors procurable being provided. On the staff are two graduates of American and Canadian engineering colleges, Purdue and McGill. The work in the drawing class is outlined in a special text book written by the company's Chief Draughtsman at Montreal, who is also the author of the book used on practical mechanics.

During the term frequent examinations are held, and the points gained by each boy are posted so that they may all keep advised as to just what progress they are making, and thereby be able to brush up the weak spots that the examinations have disclosed.

The master mechanic is constantly in touch with each boy's progress and standing, and if necessary he frequently calls a boy up, and in a kindly manner points out to him the necessity of applying himself more consistently to bring his rating up to the required standard.

Prizes for Best Work.

The annual competitive examination is always conducted by the company's chief draughtsman from Montreal, and

total amount is returned to him at the been adopted by the Grand Trunk Railway System has been in successful operation for a number of years and has been the means of supplying that company with skilled mechanics in the most satisfactory manner. All apprentices are indentured to machinist's trade for five years, and to blacksmith's, boiler-maker's, or other trades for four years. Five cents per day is deducted from the wages of each apprentice, and the

to the master mechanic or the general foreman, and to be not under 15 or over 18 years of age. He is required to undergo a medical examination so as to assure the head of the department that he is healthy and likely to be able to follow up the trade after he has completed the term of apprenticeship.

Making Apprentices Think.

Each year the apprentice must pass examinations, his whole training being with the object of making him think. His course through the various shops last five years. He is provided with instruction books and must pass his examination on these before entering the machine shop. The questions asked deal with drill speeds for various work, jigs, belts, etc.

An apprentice is required to serve five years at the following rates: 8c, 10c, 12c, 15c and 17c per hour. Before he is granted each year's advance he is required to pass a written examination on shop work, also make a drawing of some detail part of a locomotive, as specified in the apprenticeship book, which examination and drawing must have the approval of the master mechanic, and the superintendent of motive power before his advance is allowed.

All Round Competency Secured.

The above system insures thorough education in all details of the trade, and while some of the work may be specialized it is not done by the apprentice until he becomes a journeyman. For instance, the apprentice comes from the boiler shop to the machine shop, from the machine shop to motion bench, to the side rod bench, to the axlebox

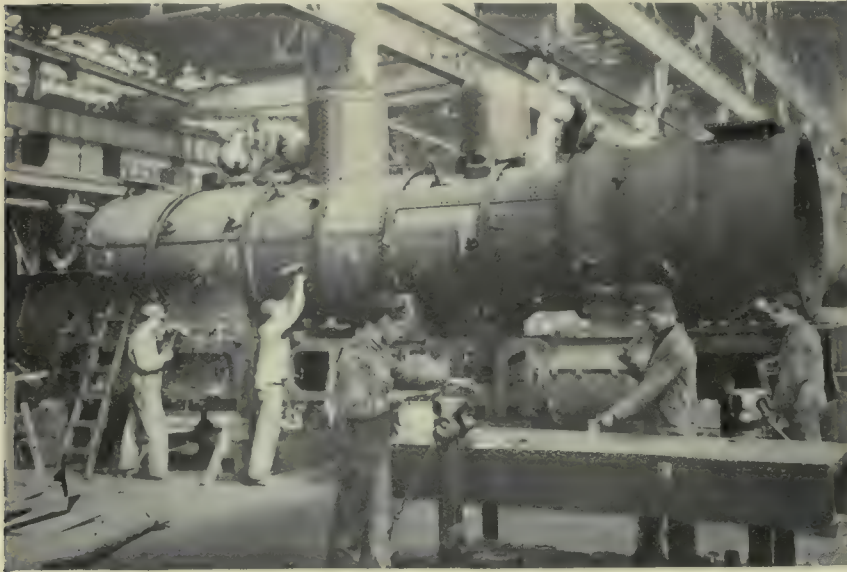

G. T. R. Apprentices at Work on a Rebuilt Locomotive in Stratford Shops.

has just been completed at all the large shops along the system. Prizes are awarded to the apprentices obtaining the highest average in their respective years. These prizes amount to \$40.00 for each shop, and are distributed over the different years of apprenticeship, thus: the apprentice obtaining the highest average for his first year in mechanical drawing gets \$4.00, and the one obtaining the highest in practical mechanics gets \$4 also. Therefore, it is quite possible for one apprentice to obtain both prizes. A keen interest is taken in this examination, which takes the form of a contest between the various shops.

In addition to the prizes as stated above there is a capital prize offered of \$25 for each subject. This is competed for by the apprentices obtaining the highest averages in drawing and practical mechanics at their respective stations. These apprentices are given a trip to some point on the system where the final examinations are held, and the one receiving the highest number of points in each subject receives the amount stated. This, in addition to what he has already received at his station, will make a total of \$29, \$33 or \$58, if he has been successful in all subjects.

The form of apprenticeship which has

expiration of his apprenticeship with an addition of \$25 as a bonus if services have been entirely satisfactory.

The first requisite in employing an



G. T. R. Apprentices at Work in the Montreal Shops.

apprentice is to know that he is morally, physically and mentally capable of filling the requirements of a mechanic. To ascertain this the apprentice is required to make his application direct

gang, to the steam pipe gang, to the valve gang, and finally to the erecting gang, so that after an apprentice is out of his time he is a specialist in any one of these branches.

Efficient Methods Followed in Shops to Reduce Costs

These Tried Out Plans are Reproduced from Factory, and Give Practical Ideas for Saving the Time of Valuable Workmen, Reducing Labor, etc. Question of Spoiled Work as Solved in Certain Factories is also Given.

The methods here given are not complicated systems of red tape. They are schemes that have been devised and tried out with great success. In present day competition schemes and short cuts assist a great deal in producing more for a dollar expended than would otherwise be possible. For any manager who is trying to get more out of his factory these examples of what other men have accomplished in the machine shop should be of special interest.

* * *

Locating the Foreman.

By R. M. Graham.

When the head of a department leaves his desk at the Browne & Sharpe Company's factory, he sets the indicator, Fig. 1, so that if he is wanted he can be quickly located by telephone.

The construction of this little indicator is clearly shown. The metal markers at the sides of the frame slide vertically on a thin metal strip so that they can be quickly set. The building numbers are printed in large figures and the telephone numbers for each department make it convenient to call the man.

* * *

Saving Babbitt Metal.

By H. S. Mitchell.

A gasoline engine factory used a high grade babbitt metal on the crank shaft bearings of its product. This babbitt was purchased in two pound cakes, and the form was such that it fit the average man's hand to perfection.

During the last money stringency the plant shut down for a few days for an inventory. While checking the machining and assembling departments the manager found that these cakes of babbitt were in use all over the shop, as hammers. No check had been kept on the babbitters, so every one had been free to help himself. As no one bothered about returning the battered chunks, most of the machines had several cakes lying on their tool stands.

The manager gathered up all the babbitt and returned it to the stores department. He had the tailings rendered from the babbitt fires and mixed in some lead. The firm purchased a babbitt hammer die and the cost clerk found some waste ends of tubing in the rough stores warehouse, that were just right for handles.

A babbiter was put at work molding hammers, and these were given out

on tool-checks, when the factory resumed operations. The money involved in the extra babbitt was not saved, because the material was available if desired, but the money was released, at a time when needed.

* * *

Economy From Using Right Machine.

By C. M. Muruhy.

In a western shop, all the sheet metal from 1-32 inch up to 3-4 inch was formerly punched on one ponderous machine. A punch of smaller dimensions had been suggested, but was thought too expensive for a time of retrenchment.

One morning the foreman went to his supplier with a slip of paper. Upon this paper were figures on the current

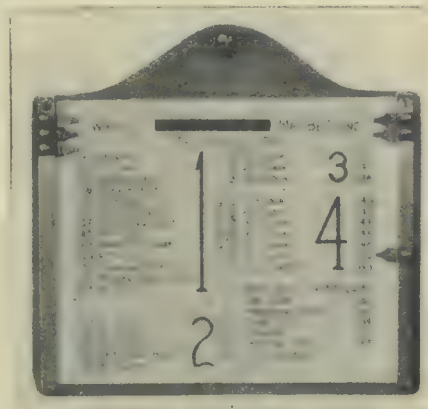

Fig. 1.—When the head of a department leaves his headquarters at Brown & Sharp's, his whereabouts are indicated by the simple little indicator here shown.

waste of time, labor and power incident to handling one class of thin sheeting on the large punch. Below was a requisition for a tiny, inexpensive air punch, and a note showing that in a few weeks the current loss would neutralize the purchase price of this machine.

The buyer had thought a much larger machine necessary. The foreman's low bid accordingly went through, and the instantaneous air punch, set down in the midst of the light work, soon paid for itself.

* * *

Making Errand Boys Responsible.

By H. M. Wood.*

At our plant messenger boys are called to different departments by a special

annunciator and push button system. The annunciator is located opposite the tool room window and is connected with fifty push button stations conveniently located throughout the plant. The annunciator location is headquarters for the boys who respond to the bell.

In establishing a basis for paying these boys it was first ascertained that on the average the boys made about fifty calls per day. This figure was taken as a standard, therefore, and each boy was allowed a premium of one-half cent for every call made above fifty a day. If he does not make more than fifty calls, he receives his regular day's pay and no premium.

The number of calls which each boy makes is recorded in the tool room just across the aisle from the annunciator and bench. The boys are numbered from one to twelve, and in the tool room one hundred brass checks about the size of a quarter of a dollar are kept for each boy. When the annunciator indicates a call, the boy next in line reports at the tool room window to run the errand, and at that time one check corresponding to the boy's number is placed in the rack. When the rack is full the boy is credited with a hundred calls and the checks are removed from his rack to be used over again.

The advantages of this system are obvious; each boy is interested to get in as many calls as possible a day, and consequently the boys respond promptly every time the bell rings.

Moreover the plan makes the boys more responsible and their job appeals to them in a business way. This is not an errand boy's ordinary point of view on his work. Each boy is uniformed in khaki and each wears a numbered shield. On the wall behind the bench is a blue print layout of the factory.

* * *

Saving Spoiled Work.

By A. R. Kipp.*

Piece work and the bonus system are, in my opinion, the only methods of wage payment correct in principle. My preference is for the piece-work system. In this the words "For value received" apply as they do in so many financial transactions, and under this system if

* Mechanical Superintendent, The Minneapolis, St. Paul and Sault Ste. Marie Ry.

* Of the Lodge & Shipley Co.

the workman spoils his work he pays for it, unless, of course, he does other damage to co-related parts beyond his control. Nevertheless, the premium is time-saving and good workmanship.

In paying a flat rate per hour, the only recourse an employer has is dismissal, which is at times when skilled labor is scarce very unsatisfactory, so that in my opinion the only solution of the problem of placing spoiled work where it belongs lies in a system of using the piecework principle.

Another question suggests itself as going hand in hand with this one, which is, "What system will present the bill for spoiled work to the proper party?" I believe the answer to this is worthy of consideration when the first one is solved.

Spoiled Work in Brass Foundry.

By Frederick C. Shafer.**

In our brass shop all piece workers pay us for the work they spoil. Of course, the total loss for the spoiled work is not covered in this repayment for spoiled pieces; but, to my mind, this method serves as a check upon carelessness.

Our day workers are not charged for spoiled work. But all the scraps from jobs are collected daily and separated into lots identified as defective in casting or in molding. This enables us to keep a check on day workers also, for

** Factory Supt. of Penberthy Injector Co.

if they spoil a great deal of work it comes automatically to the attention of the inspector, who reports the facts to the foreman and to me. The men knowing that this is done, are more careful than they would be otherwise.

In the foundry we have a method for handling spoiled work which has proved very effective. The molders are paid altogether on a piecework basis, and when they spoil work, they are charged back with it. Of course, in charging back, we are very careful that the spoiled work is wholly the molder's fault. A sheet is made out weekly and is placed in the man's pay envelope so that he has definite information as to just the amount of work he has completed.

Concise Cost System for Small and Medium Sized Shops

The Division of Expenses, Pointing out what Should be Considered Productive and what Non-productive Labor, Overhead Expense, Etc.

By GORDON C. KEITH

In a cost system for a small shop the details cannot be gone into with the same elaborateness as in larger shops some of whose systems have been described in these columns. The system for the smaller shops should be concise, taking into consideration that the proprietor must oversee both the office and manufacturing end, and often with the aid of a clerk perhaps, serves as book-keeper, time clerk and superintendent.

In all shops, large and small there are a number of items that must be taken into consideration in figuring costs. These are rent or its equivalent, taxes, insurance, depreciation of plant, interest and discount, salaries of non-producers, traveling expenses, advertising, printing and stationery, postage, telegrams, freight, cartage, supplies (oil, waste, emery cloth, files, belts, belt lacing, drills, dies, reamers, mandrels, lathe tools, milling cutters, etc.), gas and coal, donations, doctors' bills, spoiled work and bad accounts.

The following classification has been given by a writer in the Iron Trade Review. Of course a number of them will not appear in the small shop used as an example in this article. In keeping track of the various items of expense these can be eliminated. For instance there may be no stable expenses to be dealt with and therefore this item may be dropped from the list. Those that do enter in must be provided for in the cost system:

Classification of Accounts.

1. Real Estate.
 - Interest on the cost of land.
 - Interest on the cost of buildings.
 - Insurance on buildings and equipment.
 - Maintenance of land and buildings.
2. Floor Rate.
 - The sum of the real estate expenses divided by the area in square feet of the entire floor surface, gives the overhead burden on this account per square foot.
3. Power.
 - Interest on cost of equipment for the generation and transmission of power, and its installation.
 - Depreciation of equipment.
 - Maintenance of equipment.
 - Floor rate for space occupied.
 - Cost of fuel.
 - Sundry supplies.
 - Wages of engineers and firemen.
4. Light.
 - Interest on equipment.
 - Depreciation of equipment.
 - Maintenance of equipment.
 - Power necessary to run dynamos.
 - Sundry supplies.
 - Wages of electrician, etc.
5. Heat.
 - Interest on equipment.
 - Depreciation of equipment.
 - Maintenance of equipment.
 - Power, or equivalent horsepower in steam.
6. Shop Transportation.
 - Interest on equipment.
 - Depreciation of equipment.
 - Maintenance of equipment.
 - Power to run elevators, cranes, etc.
 - Wages of elevator men, shop car men, crane men, etc.
7. Machine Rate.
 - Interest on cost of each machine and installation.
 - Depreciation in value of machine.
 - Maintenance of machine.
 - Floor rate, including necessary space around machine.
 - Power to operate the machine.
8. Man Rate.
 - Floor rate portion not covered by machine rates.
 - Consumable tools and supplies.
 - Liability insurance.
9. Productive Labor.
 - Wages of all men working on hand or machine operations on actual product.
 - Man rate, of surcharge or burden per hour.
10. Non-Productive Labor.
 - Wages of superintendents and assistants, foremen and assistants, gang bosses, time keepers, time study men, speed bosses, errand boys, clerks, stenographers, tool keepers, watchmen, sweepers, carpenters, inspectors, laborers, and others when on work not chargeable to production orders.
11. Material.
 - Castings, iron, malleable iron, steel, brass, bronze, etc.
 - Forgings, wrought iron, machine steel, cast steel, etc.
 - Bar Stock: iron, machine steel, cast steel, tool steel, high speed steel, copper, brass, bronze, etc.
 - Sheet Stock: iron, steel, copper, brass, fiber, etc.
 - Miscellaneous: all other kinds in use.
12. Tools and Fixtures.
 - Tools, jigs, gages and fixtures specially made for the purpose of machining, gaging and inspecting the product.
13. General Office.
 - Real estate charges.
 - Interest on equipment.
 - Insurance on equipment.
 - Maintenance of equipment.
 - Salaries of all officials, book-keepers, stock keepers, clerks, stenographers, office boys, and all others employed herein.
 - Light, proportion according to number of lights.
 - Heat, proportion according to cubic feet of space to be heated.
 - Supplies of all kinds for use in the office.
 - Legal expenses, traveling expenses.
 - Telephone, telegraph and postage expenses.
 - Express and freight charges.

14. Sales Department.
 - Real estate charges.
 - Interest on equipment.
 - Insurance on equipment.
 - Maintenance of equipment.
 - Light, proportion according to number of lights.
 - Heat, proportion according to cubic feet of space to be heated.
 - Advertising, catalogs, circulars, etc.
 - Allowances, collections interest.
 - Legal expenses, traveling expenses.
 - Supplies of all kinds for use in the office.
 - Salaries and commissions.
 - Engineer's expenses, preliminary drawings and estimates.
 - Telephone and telegraph expenses.
 - Mailing expenses.
 - Express and freight charges.
15. Stable.
 - Real estate charges.
 - Interest on equipment.
 - Insurance on equipment.
 - Maintenance of equipment.
 - Supplies, hay, grain, etc.
 - Wages of stable men, truck men, etc.

In order to illustrate the distribution of costs under the various heads, take for example a small shop employing about fifteen hands. There are a great many of such shops in Canada, growing concerns that should have a cost system.

Shops located in power buildings pay to the landlord a fixed sum per year for space, power, heat, elevator service and watchman. The charge is about 25 cts. per sq. ft. and the shop pays so much for the space occupied by the building and not for the net available space.

Shops occupying their own ground and buildings are obliged themselves to pay for the above mentioned power, heat, elevator service and watchman, and in addition, they must pay interest on the value of the grounds and buildings, real estate taxes, insurance on buildings, repairs on buildings, power and heating plant. Except in the case of very large plants, the cost is greater than renting, but the cost would be at least 25 cents per square foot.

In figuring the amount of space required for running a certain number of men on medium sized work, without crowding, it is customary to allow 150 square feet for each man employed. This would require a shop of 2,250 square feet. This would cost \$562.50.

The real estate and water tax is included under the head of "Rent or Equivalent."

Insurance.

The rate of insurance varies a great deal and depends on the quality and arrangement of buildings, and contents, fire protection, watch service, and its location. In what is known as a mill constructed building, fitted with automatic sprinklers and good watch service, the rate is much less than other construction. Fifty dollars per year will be a small estimate, but will serve to illustrate the distribution of costs.

Depreciation of Plant.

Everything in a machine shop wears out after a time. The length of time required to wear out a machine varies greatly under different conditions, but no matter what these conditions are, the machine becomes worth less and less until it is finally not worth shop room, and has to be replaced by a new tool. The plant cannot be figured at its full cost value each year, and then finally when the machines are worn out, replace them with others, charging the cost to the expense of that particular year in which the change is made.

What is done is this. The average life of a machine is found out and the cost is divided up into as many parts as there are years of its life, and each year one of these parts is taken from the value of the plant, considering the part thus lost in the expense of operating. When thus divided up one of these parts is called a depreciation. Machines wear out in from ten to twenty years. In the first case one-tenth of the cost of the plant must be added to the running expenses each year and in the latter case, one-twentieth. In a shop such as has been suggested the machinery equipment would have a value of probably \$6,800 which includes tools, jigs, patterns, etc. If the depreciation was one-twentieth, then \$340 must be added to the running expenses each year.

Interest and Discount.

In a general way both these words mean the same thing. Interest is the price paid for money. It might be called rent. Few concerns are able to carry on business without borrowing more or less money, and while borrowing is the word used the money must be paid on a certain day and an additional sum is charged for its use.

Productive labor is understood to mean the wages of those men who work on actual production. Non-productive labor includes all labor that cannot be directly charged to productive labor.

Material covers all stock that enters into the product. This does not include tools which are included in general expense. Insurance on material is added to the cost of the material. There is also labor on the material received, but this is included in the general expenses and added as a per centage over the product.

The total therefore consists of three items: material, productive labor and overhead burden. The overhead burden includes non-productive labor, general office expense, tools, depreciation, etc.

The overhead expense is figured as a per centage of the productive labor and when the cost of material and productive labor is obtained by a time-keeping system, by adding a per centage of the

productive labor to these two items the total cost is obtained.

In some systems it is the practice to figure the percentage of overhead charge yearly, others half-yearly and still others monthly. The general expense accounts for a small shop may easily be made up monthly and for estimating that percentage, may be used for the succeeding month. The percentage varies little from month to month as a rule and the manufacturer, whether large or small can thus keep in close touch with the manufacturing costs.

CANADA'S TRADE RELATIONS.

In the March issue of Canadian Machinery reference was made to French and German tariff arrangements. A list was also given of French and Canadian goods affected by the treaty.

Attention was also drawn to the fact that a trade arrangement had been made with Germany, whereby the surtax of 33 1-3 per cent. has been abolished and German goods will now be taxed at the general tariff rates. Among the articles which Germany has chiefly exported to Canada, the duty on which is now removed are: Clocks, glue, glass, springs and axles; rolled iron or steel bars, angles and other shapes; agate, granite or enamelled iron or steel ware; scientific instruments; chemicals; dry red lead, etc.

The following goods are among those which may be entered into Germany at the conventional tariff rate: Grain, fruits, timber, greases, alcohol, leather for manufacture of driving belts, pulp-wood, etc.

Canada's preference to Great Britain was the cause of the German tariff war, which is now over. Canada has maintained that foreign nations should not coerce her in tariff law-making. Happily a tariff war between the United States and Canada has been averted by the tact of a number of far-seeing officials and Canada will enjoy the United States minimum tariff. Had no agreement been arrived at, Canada would have retaliated with a 33 1-3 per cent surtax. Canada conceded lower duties on thirteen articles mostly foodstuffs and fancy goods, and President Taft has accordingly issued a proclamation giving Canada the benefit of the United States minimum tariff.

Canada's brightest year has dawned and with a great number of industries and gigantic undertakings under way, it is essential that Canada should be at commercial peace with the many nations with which she can exchange products. Arrangements are being made for a full discussion of the trade relations between United States and Canada, when it is expected that reciprocity adjustments will be made.

Efficient Handling of Raw Material at Minimum Cost

A Convenient System for Handling Material Installed in the "Chiclet" Factory, Toronto, by W. D. Beath & Son, Toronto—It is a Modern Labor-saving Device.

The accompanying illustrations show effective methods used in the factory of Frank H. Fler & Co., Sterling Road, Toronto, for the handling of raw material. In this case it is chicle, imported in bags from Mexico for the manufacture of Chiclet chewing gum. The system is applicable, however, to a great number of enterprises, and a large number of instalations have been made resulting in a great saving of labor.

A railway siding runs into the yard and the chicle is loaded on to the carrier. From the point of unloading a covered trolley system extends to the warehouse and runs along the front of the warehouse, past several doors, as shown in Fig. 1.

When loading, one end of the carrier rests on the platform to facilitate loading. The end is then raised to the level of the other by means of the block and pulley, which may be easily seen in Fig. 2.

After loading, the carrier is moved along the trolley to the scales, where a section of the trolley is disengaged. The weight is then read direct. This completed, the trolley connection is again made, and the material is moved along until opposite the door of the warehouse where the material is to be stored. Then by simply pulling a lever the carrier is switched to the siding running into the warehouse. Fig. 3 shows the carrier being switched from the main

trolley to the branch one, running into the warehouse.

There are thus only two handlings of the chicle, unloading the material from the car to the carrier, and again from the carrier at the warehouse.

When the chicle is required for manufacture, the trolley and carrier are again used. The chicle is taken by means of the trolley to the elevator, by which it is taken to the grinding room. In returning the finished product to the warehouse the trolley and carrier are used in a similar manner. They are also used in shipping the prepared raw material to the United States factory, the scales being used in a similar manner as that described above, in re-shipping.

One point in connection with this system of trolley is illustrated in Fig. 3. Very little space is required in turning into the warehouse. It is a single rail system, and can switch and turn on a radius of four feet. The system was installed by W. D. Beath & Son, 193 Terauley St., Toronto.

RUMORED MACHINE TOOL MERGER.

There has been a rumor to the effect that a big manufacturing merger is in process of formation with Galt as its headquarters. Five large plants were mentioned, covering machine tool and wood working lines. Such a merger would require a capital of about \$2,000,000, and while there has been talk of it, and several Canadian companies have been approached, Canadian Machinery has advice from some of the larger companies said to be interested, that they are not likely to seriously consider the present propositions presented to them.

It was also reported that wealthy United States manufacturers were behind the venture, but investigation has been unable to show anyone with capital behind the scheme outside of the Canadian companies themselves. Unless some other conditions arise, the Canadian companies are not likely to hazard their interests in a new venture.

R. S. Shoemaker, for some time connected with the Pittsburg Steel Company at Monessen, Pa., as electrical engineer, has become assistant consulting engineer of the Algoma Steel Company, Ltd., Sault Ste. Marie, Ont.



Fig. 3.—Carrier Being Switched to Warehouse.



Fig. 1. — Moving Carrier Along Track, "Chiclet" Co., Toronto.



Fig. 2. Raw Material being Weighed, "Chiclet" Co., Toronto.

The Design of Bevel Gears ; Shafts Acute and Obtuse

Part II. on the Design and Manufacture of the Variou Types of Gears,
Giving Information and Tables of Great use to Mechanical Men.

By G. D. MILLS

(Continued from March issue).

The interior gear can be cut with an automatic gear cutter by slightly altering the slide, or it may be cut on a milling machine.

In order to provide correct profiles of the teeth of bevel gears, it is first necessary to determine the pitch diameters of equivalent spur gears and on their pitch circles construct the profiles, which are the profiles of the teeth of the bevels on the edge line. The radius of the pitch circle of either spur gear is readily obtained graphically, by extending the edge line where the wheels mesh, in either direction, until it intersects the centre lines of both shafts. Its length is the distance from this point of intersection to the centre line of teeth as they mesh, and the angle at this point of intersection, is the compliment of the centre angle. The radius may be calculated by dividing the half pitch diameter of the bevel gear by the sine of angle at point of intersection, or cosine of centre angle. The pitch diameter of an equivalent spur gear is therefore the pitch diameter of the bevel gear, divided by the cosine of its centre angle, and since the numbers of teeth bear equal proportions

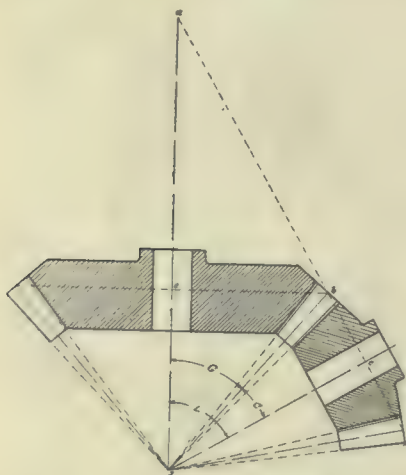

Fig. 8.—Gears With Shafts Acute.

to the pitch diameters, our formula, "number of teeth to select cutter for" is therefore the number of teeth in the bevel gear, divided by the cosine of its centre angle. Correct profiles of the large and small ends of teeth should be provided during the operation of cutting the teeth, that the blank may be

tried direct or with a gauge, and any defects remedied by filing.

In Figures 8 and 9 which follow, will be found another method for obtaining the centre angles of acute and obtuse shafts, which presents many attractive features. In Fig. 8 are arranged a gear and pinion with shafts at an acute angle. In the above we have the angle of shafts L also the two pitch diameters. Tangent C is found by dividing the half

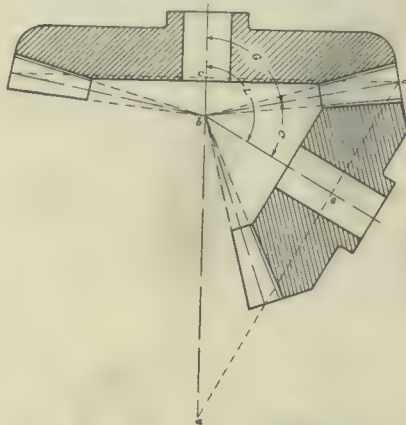

Fig. 9.—Gears With Shafts Obtuse.

pitch diameter of pinion or length be by length ed which length however must be calculated. It will be noticed that the pitch diameter of pinion has been extended until it intersects the centre line of gear shaft at the point a, and that in the right triangle acd, the angle L is one of its angles. The angle at a is therefore the compliment of angle L. In the upper portion of Fig. 8 is a certain other right triangle acb. If we divide the half pitch diameter of gear or length eb by the sine of angle at a or cosine L, we shall have the length ab which is added to be and our length de is then ac multiplied by the tangent at a or cotangent L from which is derived this formula for acute shafts. Tangent C=

$$\frac{N_2}{\left(\frac{N_1}{\cos. L} + N_2 \right) \text{Co} + L}$$

Angle G=L minus C.

Shafts Obtuse.

In Fig. 9 will be found a diagram of two gears with shafts at an obtuse angle.

As before the pitch diameter of pinion has been extended until it intersects the centre line of gear shaft at a,

the triangle being reversed in this case, and we have the angle of shafts L also the two pitch diameters. Tangent C is therefore the half pitch diameter of pinion divided by the length be which length may be calculated in the right triangle abc. The angle at b is the supplement of angle L and its compliment is the angle at a. The enclosing right triangle acd has for one of its sides the half pitch diameter of gear or length cd which divided by sine a or cosine L gives us the length ad from which is deducted the half pitch diameter of pinion or length de. Our distance be is therefore length as multiplied by the tangent at a or cotangent L and from which is derived this formula for obtuse shafts, tangent C=

$$\frac{N_2}{\left(\frac{N_1}{\cos. L} - N_2 \right) \text{Co} + L}$$

Angle G as before equals L minus C. Figures 8 and 9 still further verify the method as set forth in Fig. 2, since the results obtained are the same by either method. While the graphics of these last two figures are more brief than that of Fig. 2, the formulas obtained by the first method are to be preferred. It has been the writer's aim to fully set forth and prove the methods from which the centre angle formulas are derived and to provide practical examples for their application. I am sure the necessity for each operation will be apparent to every one who has practical designing of this kind to do. Bevel gears when new should mesh as close as possible without actually binding since the wear on the teeth will in time make them loose, and for this reason spiral gears are often preferred as the screw like motion of spirals take up the wear on the teeth so that it is almost imperceptible. They, therefore, wear longer and may be set at any angle, or made to mesh with a spur gear, the array of formulas and graphics connected with spiral calculations, however, is greater than for bevel gears.

G. Y. Chown, B.A., Registrar and Treasurer of Queen's University, has reconsidered his decision and will retain his connection with the University in the above capacity,

Machinery Equipment for N. T. R. Shops, Winnipeg

Machinery and Tools, Motors, Furnaces and Forges, Cranes, Air Compressors, Grey Iron Foundry Equipment, Brass Foundry Equipment, Belting, Shafting, Hangers, Industrial Track, Lockers, Etc.

The building and equipping of the National Transcontinental shops at Winnipeg is one of the largest undertakings of its kind that has been undertaken in Canada. When one considers the size of these shops it will be understood that the equipment will cover a large and varied line.

The shops consist of fourteen units, as follows:—

1. Round house to accommodate 25 locomotives.
2. Locomotive shop, 823' x 174' with 26 engine pits.
3. Store house, 62' 6" x 262'.
4. Forge shop, 104' 9" x 264' 9".
5. Oil house, 30' x 40'.
6. Power house, 154' 9" x 110'.
7. Carpenter shop, 104' 9" x 74' 9".
8. Watertank of 100,000 gals. capacity.
9. Chimney 200' high.
10. Grey iron and brass foundries, 204' 9" x 134' 9", with cleaning room 64' 9" x 82' 4½".
11. Crude oil storage, 25' x 62'.
12. Frog shop, 64' 9" x 104' 9".
13. Storage platform, 56' x 180' and superstructure, 58' x 151'.
14. Iron storage, 30' x 60'; coal, 30' x 30'; coke, 30' x 20', and scrap, 30' x 100'.

The shops are located at Springfield, east of Winnipeg, and the work on the pumping plant and reservoir must be finished and the machinery ready for operation by August 1, 1910. The buildings are nearing completion, and it is expected that the works will be in operation by Jan., 1911.

Power Plant.

The current to be used is 3-phase, 60-cycle 550 volts, alternating current.

The air compressor will be of the horizontal type with two-stage air cylinders designed for motor drive. It will have a capacity of 660 cubic feet of air and speed of 150 r.p.m. Air will be used at from 80 to 120 lbs. per sq. in. The air valve inlet gear will be of the Corliss type. The outlet valves will be of the high speed type.

Machine Tools.

The machine tool equipment makes a long list of machines of well-known types. These include lathes, drills, shapers, planers, grinders, boring machines, etc., necessary for efficient work in the

construction and repairing of locomotives.

The shops have been divided into departments and the tools will be arranged in groups. There are two general groups in the locomotive shop. No. 3 and 4 are the piston, motion and crossheads; 5, tool, 6, 7 and 8, are bolt departments; 9, rod; 10, brass; 11, 12 and 13, boiler and tank shop, and 14, flue and pipe shop.

A number of the tools will be equipped with individual motor drive including bending rolls, 200-ton hydraulic press shears, 42" car wheel lathe, etc. There will be a number of hydraulic machines including punches, riveters, 560-ton hydraulic forging press, 4-column type, etc.

The forge shop will have machine tools for cutting, centreing, forging, etc. The hammers will be two of 200, one 1,250, 1,500, 3,000, 3,300, 3,500 and 5,000 lbs. There will also be hydraulic bulldozer, squeezer, etc.

The scheme of grouping is being carried out in all the shops, so that work will pass through the shops with the least number of handlings.

Cranes.

The locomotive erecting shop will have one 120 and one 10-ton electric crane; machine shop, two 10-ton; boiler shop, one 30 and one 10; riveting tower, one 20; tank shop, one 20 and one 5; grey iron foundry, one 15-ton with a 5-ton auxiliary hoist for light work; cleaning room, one 5-ton; forge and tank shop, one 10; and yard midway, one 10-ton. These are all electric. There are also the following hand hoists: power house, one 10-ton; stores, one 10; and grey iron foundry, three 1-ton. Jib and bracket cranes are also arranged throughout to facilitate the handling of work when the large cranes are in use.

Foundry Equipment.

One cupola will be 50' in height, shell 84" diameter; wind box 104", with 12 tuyeres. The second will be 50' in height, with shell 72" diameter, wind box 92", shell of cupola to have 12 tuyeres.

A 40 h.p. motor will drive the blowers. The cupolas will be equipped with pneumatic charging machines and the charging floor will be served with a 4,000 lb. pneumatic elevator. Tumblers, grinders, core oven, pneumatic sand sifters, ladles,

brake shoe, molding machine etc., will form part of the equipment.

In the brass foundry will be four 26" diameter brass furnaces, and one 32" diameter, core oven, metal cutting band saw, sprue cutter, tumblers, axle brass molding machine, etc.

Thousands of feet of belting will be required for the various shops. In each shop there will be a number of tools specially designed for the work in the new shops of the National Transcontinental at Winnipeg. When completed the shops will be among the most modern and best equipped on the continent.

PERSONAL NOTES.

W. R. Sweaney has been appointed business manager of the Toronto Electrical department.

D. MacDougall has been appointed assistant general manager of the Dominion Iron & Steel Co., Sydney, N.S.

Mrs. Main, wife of J. J. Main, manager of the Polson Iron Works, Toronto, died in March after a few hours' illness at her home in Toronto.

Mr. Mitchell, superintendent of the Dominion Iron & Steel Co., Sydney, has been visiting the steel centres of the United States investigating the latest practice and ideas for the new mills to be installed this summer at Sydney.

J. J. Foote, manager of the McClary Mfg. Co.'s Winnipeg warehouse, spent a day in Toronto last month, on his way back home from a visit to the London head office. He reports bumper business in the west and expects this fall to outdo the record established last year.

J. C. MacLeay, superintendent of blast furnaces, Dominion Iron & Steel Co., Sydney, was severely injured on March 19. One of the workmen accidentally poured cold water into a hot slag pit causing an explosion in which Mr. MacLeay and five workmen were injured.

Those who perused the "First aid to the Injured" article in Canadian Machinery for February will be further interested to note that the writer of the article, S. A. Gidlow, has had the distinction conferred upon him of Hon. Associate of the Order of St. John of Jerusalem in England. This honor was conferred upon Mr. Gidlow by King Edward upon recommendation by the Prince of Wales, who is the Grand Prior of the Order.

SYSTEM AT BALDWIN LOCOMOTIVE WORKS.

There is surely a reason for the progress of large manufacturing establishments. Take for instance, the Baldwin Locomotive Works, there is a firm of world-wide reputation. In these works are built locomotives, not only for American railroads, but for roads in almost all countries in the world, thus competing successfully with the locomotive manufacturers in all these different countries. There must be a reason why locomotives can be built at Philadelphia, shipped to any country in Europe and placed on the roads there for the same cost or less than they can be built in shops in that country. Giving all due credit to the national advantages this works has, because of its geographical position, the greater part of the credit must be due to the management of the works, a review of the chief points in the management policy of this establishment would probably throw some light on the reason for their success.

In these works are employed in the neighborhood of 15,500 men, distributed among 20 departments. The executive consists of one superintendent, four assistant superintendents and twenty foremen, one for each of the departments. The foreman in each department has assistant foremen and underforemen according to the size and importance of the department. Each under-foreman is a specialist in his line of work. Each department is a factory in itself, turning out special parts of the locomotive. Each department is operated on contract or piece work system. Now there is considerable diversity of opinion regarding the best methods of paying labor, but the success or non-success of any system of payment does not depend on the system alone, but also on the way the system is managed. It is the claim of the Baldwin Locomotive Works that under careful management they get more work per man out of their piece workers than any other similar concern in the world, and that their men are allowed to make higher wages. Dissatisfaction is rare at Baldwin's, and they have no strikes.

No attention is paid to unions at Baldwin's. A man is hired on his own merits, and after he enters the works he is expected to abide by the regulations of the shops.

Their system of apprenticeship is worthy of notice. They find their apprentices of great value, simply because they have been brought up in the work and therefore are much better able to fill positions in the works than any me-

chanic unacquainted with the system. The apprentice system is as follows:—

The apprentices are divided into three classes, i.e., first, those with an ordinary public school or grammar school education; second, those with a high school education; and third, those who are graduates of a technical school. A first-class apprentice must be 17 years of age. He serves 4 years; and during that time he is moved from one department to another until he has been through the whole works. He attends night school two nights in the week to take up mathematics and mechanical drawing. His pay ranges from \$3 to \$6.60 per week during his apprenticeship, and on completion of his time receives a certificate and \$250. A second-class apprentice serves 3 years instead of four and gets from \$4.20 to \$6.60 per week, and upon completion of time receives a certificate and \$200. He also attends night school. The third-class apprentice serves 2 years, and does not attend night school. He gets from \$9 to \$12 per week and a certificate upon completion of time.

There is another feature of the management that goes towards making the firm what it is. The foremen of the different departments are encouraged to improve existing conditions, and they are sent by the firm all over the country to see and appropriate new ideas. If a foreman can prove that by the installation of some new machine, work can be handled in a more economical manner, he is furnished with the machine without any question, and in this manner the works are kept up-to-date in every particular. Because they are up-to-date in every particular is a very substantial reason why they can compete with manufacturing plants so far away from home. Many of the shops in England, Sweden and Russia are 25 years behind in equipment.

Thus the secret of success in manufacturing is to keep up with the times.

IRON BOUNTIES TO CEASE.

The Dominion Government has announced that it would not renew the iron and steel bounties at the end of the coming fiscal year. The bounties have been in force fourteen years and the Government believes the industries are now established on a sufficiently firm basis to stand alone. These bounties were fixed on a sliding scale for different iron and steel manufacturers, decreasing year by year, and varying from \$2.10 per ton for pig iron produced from Canadian ores in the calendar year 1907 to 40 cents per ton for pig iron from foreign ore produced this year. The extent to which these industries have grown is shown by the fol-

lowing schedule of bounties paid during the year ending March 31, 1909 :

Pig iron	\$693,423
Steel	838,100
Mfrs. of steel	383,091

Total\$1,914,614

Since 1896 a total of over \$14,000,000 has been paid in iron and steel bounties, the abolition of which will not affect the protection of \$1.50 per ton upwards imposed on imports of iron and steel.

BROWNING ENGINEERING CO.

The Browning Engineering Co., Stop 118, Shore Line, Cleveland, Ohio, have been installing a number of locomotive cranes in Canada. They have had a number of requests for operators for their locomotive cranes and are anxious to have the names and addresses of available men on file for positions as they open up. Two important installations were described in a recent issue of Canadian Machinery. These were at the Canadian Locomotive Works, Kingston, and Angus Shops, Montreal.

BOB'S BALKY PUMP.

By C. Tuells.

Bob was a good-natured, curly-headed apprentice boy in the best and largest machine shop in town. He had passed the days when the men used to send him to the blacksmith shop to get the teeth of a file drawn out a little longer, or to the stock room for a half-inch counterbore with a five-eighths pilot. As he was in his second year, he got fairly good work—compared with turning pulleys and snagging castings, or running errands and "chasing the broom."

He was now at that stage of the trade where he was commencing to earn a little money for the company, for he could make a simple machine or a plain jig as well as most of the journeymen, and there was quite a difference between his thirteen cents an hour and the journeyman's thirty, which went on the right side of the books.

One day the boss brought around the blue-prints and castings for a rotary pump and gave Bob instructions how to make it. It was his first pump, so with all the vigor of ambitious youth he "waded into his job." He bored out his casting for the pump casing, turned up his gear blanks, and made his union as good and as quickly as the best of the men could do. True, he slipped up cutting one of the gears, but he hustled out a new blank, and this time his gears were cut the right number of teeth and the proper pitch.

After three or four days of interesting work his pump was completed and ready to be tested before being sent out of the shop. In "trying out" a rotary pump, it was customary to set it up on the ways of an old lathe, with the pump spindle in the chuck and the inlet and outlet pipes reaching to the floor into buckets; in this way, by starting the lathe, a bucketful of water was pumped from one bucket to the other, when everything went right.

Well, Bob got his pump set up all right, and it pumped, and pumped good, too. After pumping a few bucketfuls he shut off the power and went to get the boss to inspect the pump and see it work—his mind in that harmonious state that always accompanies a successful job.

In the meantime, two of Bob's brother apprentices conceived the brilliant idea of inserting a large cork stopper in the end of the inlet pipe and pushing it up out of sight.

Bob soon came back with the boss, who, after looking it all over, ordered him to start the pump. The pump started all right, but, strange to say, there was "nothing doing" at the outlet end, much to Bob's astonishment, and all attempts to make it pump were in vain.

The boss looked dubious and Bob looked worse, but the sly glances his fellow apprentices cast in his direction were full of fiendish glee. After telling Bob to "pull her to pieces and see what's the matter," the boss left Bob to work



"There was nothing doing at the outlet end, and all attempts to make it pump were in vain."

out his own salvation. Although he took the pump apart and examined every inch of it thoroughly, he could find nothing wrong, until he tried to look through the inlet pipe—he couldn't see light. Then Bob knew what the

trouble was, and another leaf was added to his book of experience.

Back together went that pump in double-quick order, and this time it worked fine and to the satisfaction of the boss. Bob's detective abilities traced the stopper to the empty bottle in his shop-mates's dinner box, and it wasn't long before he was paid back in his own coin—but that's another story. —Machinery.

When comparing competitive bids on direct current electric motors one manager always keeps in mind the fact that the cost of the machines increase with the horsepower, but decreases with the speed.

For emergency work about the boiler shop, the foreman of a locomotive factory constructed six small hand trucks, heavy and low wheeled. On three of these he rigged anvils: on the others, forges. When a bit of smithy work is needed on some massive part, such as a boiler or firebox, one of these forges is dragged in and connected with the air main. The anvil follows; and the work is done, independent of other smithing, in quicker time than work could be taken to the blacksmith department, run through the routine and returned.

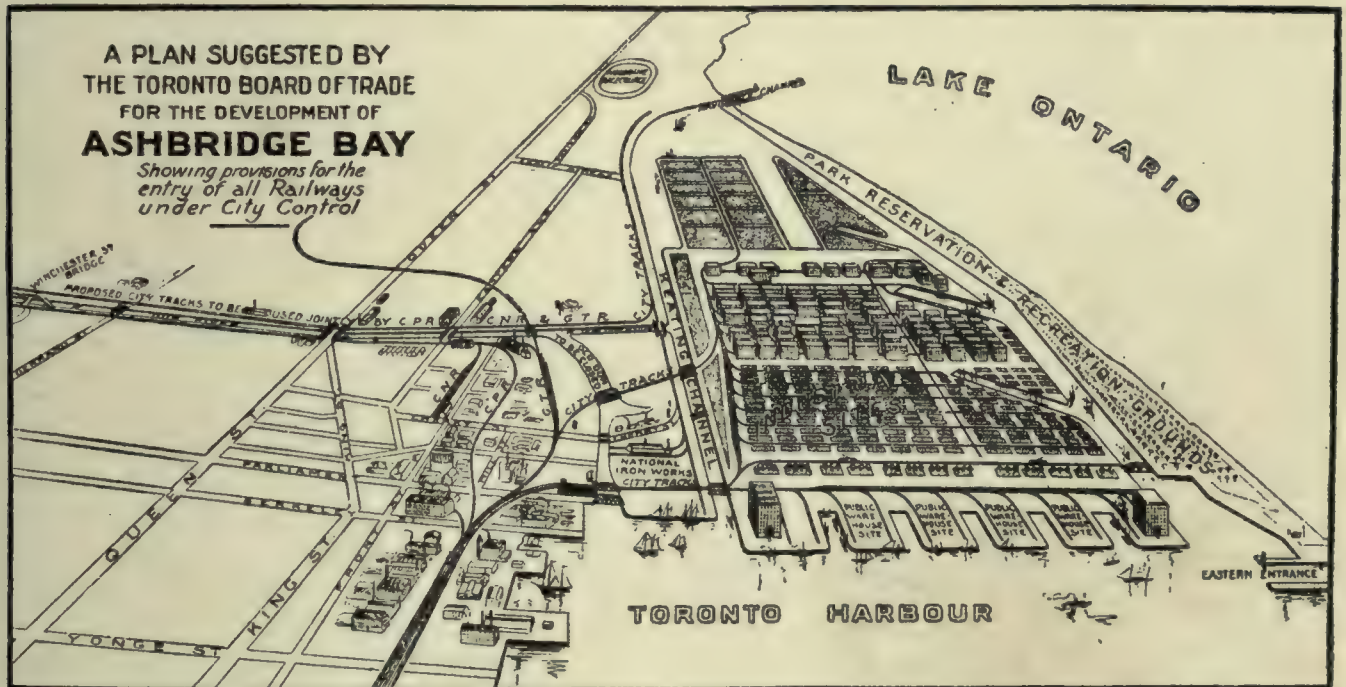

At a luncheon given by President W. J. Gage to members of the Board of Trade, Toronto, recently the following resolution was unanimously passed:—

"Whereas the Board of Trade of the city of Toronto consider the control of the waterfront in and contiguous to Toronto is essential to the commercial development of the city;

"And whereas no satisfactory plan of development can be devised and carried out without permanent concentration of authority;

"And whereas the proper development of the waterfront will enrich the city many millions by enhancing the actual value of its property in Ashbridge's Bay and elsewhere;

"Be it therefore resolved that this meeting most strongly urges placing the management of our waterfront in the hands of a commission, and that the Secretary be instructed to forward a copy of this resolution to the Mayor, Board of Control, and Council of the city of Toronto, with a request for immediate action."

MACHINE SHOP METHODS ^A_N^D DEVICES

Unique Ways of Doing Things in the Machine Shop. Readers' Opinions Concerning Shop Practice. Data for Machinists. Contributions paid for.

SAWMILL DEVICES.

By Staveley.

For the purpose of lifting round logs on to rack benches or timber frames, a suitable device is necessary for carrying out this operation quickly. If the logs



Fig. 1.—Logging Hook.

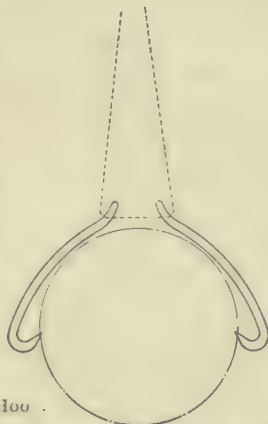

Fig. 2.—Gripping a Log.

come into the mill, drawn up by an endless chain, they rest on the floor, and there is no way of passing a sling chain under, or if there were this would take a longer time, than the hooks shown in Fig. 1. These are made from a good class of $1\frac{1}{2}$ " x $1\frac{1}{2}$ " iron, and a $\frac{3}{8}$ " chain goes through the eye of each and through the ring which is attached to the traveling crane hook overhead. Fig. 2 shows the hooks gripping the log, which slide

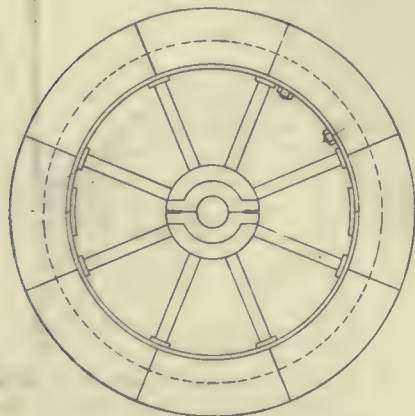

Fig. 3.—Pulley Lagged With Timber.

or adjust themselves on the $\frac{3}{8}$ " chain, as in the sketch. The hook points are sharp and hardened, so that they dig themselves into the log, when the slack is hauled up.

Fig. 3 shows how a W.I. pulley in halves can be lagged with timber, either for a belt or rope drive. In the figure, it has been shown for a rope drive. The segments are cut from well seasoned hardwood, the grain running radially. The segments are well bedded to the rim and fixed by tee-headed bolts let into the wood, so as to clear the ropes. By removing the segments over the lap plates, the pulley can be removed in halves in the usual way.

ABOUT CATALOGUES.

By K. Campbell.

There are other troubles for the recipients of catalogues besides the filing of the heterogenous collection of catalogues that are necessary in a well managed manufacturing plant. We successfully disposed of the filing difficulty by using vertical files and following the

\$10 For An Idea

For the "Machine Shop Methods and Devices" department of Canadian Machinery.

We want ideas for this department—ideas of practical, labor-saving, cost-reducing value. We will pay at regular rates for each idea accepted, and in addition will pay \$10 for the best idea submitted during the next six months—that is, until Sept. 30, 1910.

Address all communications to the Editor of Canadian Machinery, 10 Front Street East, Toronto, Ont.

same manner as in letter filing. In this connection, we used a double card index in which the names of the companies were tabulated alphabetically with a list of the lines manufactured given on the card of each company. On the second index the various articles in which we are interested were listed alphabetically and on each card the names and addresses of the companies manufacturing these lines were given.

The point I wished to bring to the attention of those issuing catalogues is to be sure to have the name and address of the company on the catalogue. In fact it is a good idea to have it on every page. A page is often torn out and sent to the superintendent or foreman. It is returned only to find that there is no name on the page to tell from which catalogue it was taken.

The one in care of the index must trust his memory and if there is a page from one catalogue sent to the foundry foreman, another to the carpenter shop, the pattern and a few other departments, it is practically impossible to trace some of the pages. It would be an easy matter to have the name and address of the company on every page.

The technical, trade and daily press are careful to have the name and address on every page and the manufacturer who issues catalogues would do well to follow this example. Orders are sometimes lost through this neglect.

Perhaps it would be hard to believe, but it is a fact, that catalogues are received in our office containing no name or address to designate the company issuing them. British manufacturers are the chief offenders in this regard as far as I can learn. We have received catalogues on which there was absolutely no name or address and consequently, if we had not been interested in the lines the catalogue would have been relegated to the waste basket instead of following up the trade-mark and thus locating the name and address after a great deal of inconvenience. It is an easy matter to carry out the suggestion of having the name on each page and is worthy of consideration.

FRICITION CLUTCH REQUISITION FORM.

The two illustrations shown are used in connection with ordering friction clutches by Vandeleur & Nichols, Electrical, Mechanical and Constructional Engineers, Dineen Bldg., Toronto, but they may be applied to requisitions in the factory and in ordering various articles and equipment.

Standardizing will allow the use of this method of making drawings. In connection with the clutches the various measurements are indicated only. The sizes are filled in to suit the conditions under which the clutch will be operated.

In ordering a clutch a customer is asked to give the following information:

1. Maximum horse power in ordinary work.
2. Maximum horse power at starting (which is generally greater than 1.)
3. Revolutions per minute.
4. How often in the 24 hours will the clutch be put in and out?
5. Are there any heavy masses, fly-wheels, large belt, or rope pulleys, heavy machines, etc., to be put in motion? If so, give particulars.

CANADIAN MACHINERY

- 6. What kind of machine or machines is clutch to drive ?
- 7. What kind of motor drives clutch—steam, gas, oil, electric, turbine, etc. ?
- 8. If clutch couples shafts, give their diams. and fill in dimensions in sketch below.

In the columns A, B, C, etc., are entered the check numbers of those who are absent. In the column at the right are entered the total number present, the number on the roll and the corresponding figures for the year previous.

One of these forms is filled out for each working day so that the general manager can tell at a glance each day, the number on the roll, those absent, any new men starting and those leaving the employ. If any department is behind on the work the foreman of that

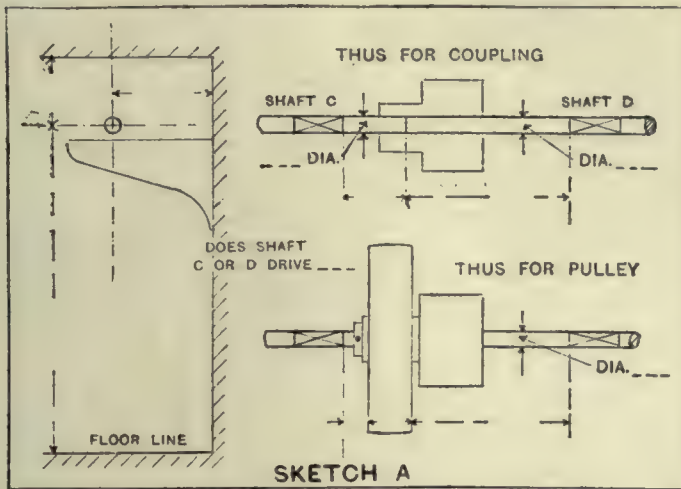

Sketch A.—Clutch Requisition.

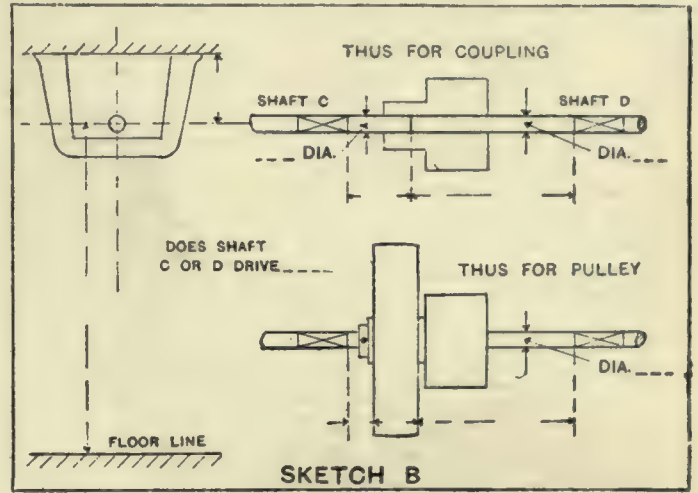

Sketch B.—Clutch Requisition.

If the clutch is to carry belt or rope pulley, gear wheel, etc., state, in addition to the above :

- 9. Diam. and width of pulley, width and thickness of belt, or particulars of gear wheel.
- 10. Diam. of rope pulley ; number of grooves ; size of ropes.
- 11. Does pulley drive shaft, or shaft pulley ?

At the foot of the sheet is given the check number and name of each new employe and workman leaving the employ of the company. In the case of those leaving the employ, the reason is also stated.

department, the superintendent, and general manager can co-operate in obtaining sufficient men to keep up the work. The form keeps the general manager in close touch with the conditions in the shops.

- 12. Average length of time per 24 hours during which clutch would be out of gear with either part running.

13. Give shaft diams. and fill in dimensions on sketch below.

- If striking gear is required :
- 14. If the shaft is carried as either sketch A or B, fill in dimensions on that sketch. If neither meets your case, give rough sketch in space below (or on back of form), showing how shaft is carried, whether in slings, hangers, brackets, pedestals, etc., and giving dimensions corresponding to those in sketches A and B.

Where a number of articles are manufactured with variations in certain measurements these could be left as in the accompanying illustrations and filled in on the blue print.

Another method, and one that is used a great deal, is to designate the distances by letters. Then when an article is required a table may be prepared giving the measurements for the various letters.

TIME KEEPER'S DAILY REPORT.

The accompanying illustration shows the form submitted by the time keeper to the general manager every morning, at Frost & Woods, Smith's Falls, manufacturers of agricultural implements.

TIME KEEPER'S DAILY REPORT.

190

Total Absent.....

Machin	Wood	Forg	Flow	Fdy	Paint	Pack's	Ship	Cartg	Extr	Exp'tal	DEPARTMENTS	ON ROLL	AT WORK	ON ROLL	AT WORK				
A	B	C	D	E	F	G	H	I	J	K	L	M	N	O	P	NO	NO	NO	NO
											MACHINE								
											WOOD								
											FORGE								
											FLOW								
											FOUNDRY								
											PAINT								
											PACKING								
											SHIPPING								
											CARTAGE								
											EXTRAS								
											EXPERIMENTAL								
											TOTAL ON ROLL								

STARTED WORK

CHECK	NAME	DEPT.	CLASS	CHECK	NAME	DEPT.	CLASS

STOPPED WORK

CHECK	NAME	DEPT.	CLASS	CHECK	NAME	DEPT.	CLASS

BURNING A WIRE CABLE IN TWO.

The quickest and best way to cut a cable, is to place it in the forge fire and burn the strands in two. Almost any size or kind of hoisting cable may be easily separated by this method.

First mark the place to be cut and hold the cable in the fire until there is a shower of sparks thrown off. Begin pulling on both parts of the cable at this time and when it is heated to a welding heat give the parts a good hard twist in the direction of the strands. This will pull the cable apart where it is heated, leaving the wires at each end all welded together and tapering down to a smooth point. Such an end does not need any wrapping to keep the wires that form the cable from coming apart.

ELEVATOR TROUBLES.

By J. H. Shales.

As a rule troubles arise from lack of attention to the machines, by those in charge. As long as a machine will respond to power, it is let run regardless of its physical conditions. It may have badly worn cables, or rust eaten piston rods, or burnt out contacts, no oil in worm gear, worn out bearings, safety out of order and a host of other infirmities. But as long as it will go up and down, people will use it, jeopardizing their lives and limbs, month in and month out. I have been called in to examine elevators in this city that had been in use for months without having a drop of oil put on the running parts or overhead sheaves. I have seen overhead sheaves bearing cut down through the babbitt and 1/4-inch into the metal and the shaft scored so that we had to put in new ones. This happens in scores of buildings.

I have one in mind that came under my notice two years ago in a leading hotel within a block of where we are assembled. The manager and engineer's attention had been called to the worn out condition of the machinery, but they thought it could run a little while longer, and so it went on until the armature gave out through over work, and they had to shut down for four days and make repairs, costing them four times the amount that it would have done if they had given it proper care. It is surprising how careless the owners of buildings are about their elevators. And when their attention is called to the need of repair, they will say it should run without looking after, forgetting that iron and steel want looking after as well as the human body.

This brings to mind a case I had some years ago of an electric elevator I had installed in one of our large hospitals. It had been in some months

and was giving trouble occasionally through not having a steady operator. On this occasion, as I was leaving the building, I was met by the medical superintendent and was asked if the machine was all right now. I said: "Yes." "Well, how long will it stay that way?" My reply was the Irishman's answer, by asking him: "Doctor are you well now?" Of course he said "Yes." "Well how long will you remain that way?" Needless to say, I was not asked that question again, although I have done the repair on that machine for seventeen years. This is but one of hundreds of thoughtless questions we have to answer in our business.

Fifteen years ago we had great trouble in getting architects to give us room to put in elevators. They thought any old place was good enough for the elevator, forgetting that those machines would need repairs. And through this short-sighted policy it has cost owners hundreds of dollars for repairs which would have been saved if the machine had been placed where they could have been looked after.

NOTICE TO SUBSCRIBERS

Subscribers will confer a favor on us by notifying us in case they are not receiving their paper regularly, or if they find they have missed one or more issues. We send out thousands of copies each month, and it is only natural to suppose that a few copies will go astray in the mails, even though every precaution is taken by us to avoid this.

We should also be notified at once of any change of address, giving both old and new addresses.

In one of our large office buildings we were installing a first class hydraulic plant, and when we came to set up our valves and control machinery, we could not get them in place on account of having a small lavatory in the way. This room is 5x6 on the ground floor with a large lavatory within 20 feet on the same floor. After a great deal of coaxing, the architect gave orders to move the terra cotta wall 18 inches. This just gave us room to get our machines in position. But for the last 18 years, every time there are repairs made the architect is cursed for his folly, as the small room is not used and is of no value to the building for revenue. I have met with instances like this in my 25 years' experience in elevator work.

My advice to all persons in charge of elevators, is to give them the same attention you would give a steam engine, as they are only hydraulic electric engines in the true sense and produce power to operate the cages.

If your plant is an electric one, be

sure that all contacts are clean and have good faces. Also that all connections are firm and tight. Those parts should be gone over and tested every day. Also keep an eye on all ropes, overhead sheaves and bearings. Also keep your girder well oiled and car properly adjusted as well as cables tuned up. When this is done on either electric or hydraulic machines, you will be all right.

LOCOMOTIVE SHOP REPAIR JIGS.

Repairing locomotives is a very different proposition from almost any other work I know of, and requires different treatment, says a writer in the American Machinist. Micrometers are an unknown

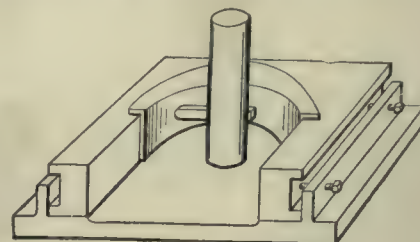

Fig. 1.—Boring Driving Boxes.

quantity in most of the work, yet the results are probably as good as can be expected, when the service is considered. Side rods must have play on the pins, both as to diameter and end movement, varying from 1-64 to 1-32 inch, because the different crank pins are almost never in line on account of frogs, switches and high and low spots in the track. But the main rod has to be as close as it will run cool, on account of pounding out the brass, to say nothing of the noise.

Rebolting a Frame.

When an engine comes in for general repairs and the frame bolts have to be driven out, it's a case of new bolts when the engine is put together again. These bolts have a taper body and drive into the reamed taper holes of the frame. The taper is usually 1-16 inch to the front.

This is usually a case of fitting each

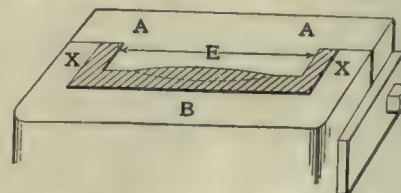

Fig. 2.—Crosshead Babbitting Jig.

bolt to its place, as the holes are just cleaned up with the reamer in the air drill. This fitting has to be well done, as it is very important that they should not work loose.

To do this rapidly, the foreman in charge of this work at the East Buffalo

shops of the Delaware, Lackawanna & Western road has a portable outfit which he sets down near the track the engine is on. This outfit consists of a lathe, a centring machine and a grinding wheel for sharpening tools, all tied together on one base and driven by an independent motor.

A bright boy completes the outfit and the combination gives star performances when it comes to fitting up a locomotive frame with new bolts. The bolts are centered and the ends all threaded to standard size before the frame has been reamed, and as soon as a few holes are ready the boy gets busy.

He sets a pair of inside calipers to both ends of the first hole to be sure and get the right taper set in the lathe, then he starts in, only measuring one end of the rest of the holes, and turns each bolt to fit its hole. There is no micrometer about it; he just sets his outside calipers by the inside calipers set to the hole, measures by "feel" in the old-fashioned way, and does a good job in a lathe that had seen hard service long before it joined the bolt-turning outfit.

Detecting Cracks in Frames, Rods and Axles.

Every railroad shop has its hair-raising story of axles that have dropped in two on the turntable after a hard run and other cases, all depriving the yellow journals from a prominent display of scare headlines about another wreck, and the best or worst of it is they are true. In no place is the effect of constant vibration better shown than in railroad service, the most prominent defects occurring in frames, rods and axles, all of which are hard to detect unless they are very pronounced. The hammer test helps in many cases where the man is trained for the work, but even this is not infallible.

The master mechanic at these shops, B. H. Hawkins, has introduced a method that is at once simple and efficient whether it is original or not. When an engine comes in for repairs and is stripped, the frames, axles and rods are given a coat of a white water paint. This dries in about an hour and does not rub off readily.

Then, as the wheels are turned up in the lathe, or the frames and rods worked on in any way, or even without it, the oil and dirt that are in any crack in these parts work through this paint and show a dark streak so plainly that it cannot be mistaken. At the time of my visit a driving axle had just been discarded, owing to a slight crack just starting from the round corner of a keyway for the eccentric, and which would never have been discovered in any other way.

The same thing holds good in the other parts, and cracks are constantly discovered that might cause accidents later had they not been found. So a little white paint is probably a life saver when applied in this way.

Boring and Facing Driving Boxes.

Two Bullard vertical lathes or boring mills with a side tool carriage or head, are in use here doing all sorts of face-plate work. The way in which driving boxes are bored is interesting as showing the use to which the side head is put as well as the method of holding and boring.

The lower plate or fixture is bolted to the face-plate, and the driving boxes fit in this and are easily centred and set.

There are several sets of these jigs of different widths at C to allow for guides being planed down on the sides to true them up at different times. These cost very little to make and have been handling all the babbitting done here for some time.

GRINDING CIRCULAR CUTTERS.

By J. H. R., Hamilton.

The accompanying sketch shows an attachment placed on an ordinary emery jack for grinding circular cutters. The shaded portion of the sketch shows the attachment in position.

The piece P is secured to the two brackets BB. On one end of piece P is the compound rest R, the top table of

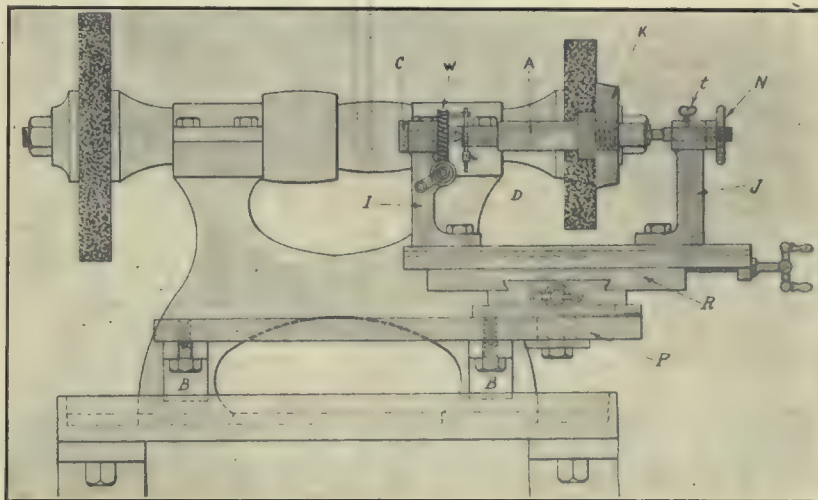

Grinding Circular Cutters.

A mole in the centre of this plate forms a guide for the pilot on the boring bar, as shown in Fig. 1, holding it steady in its work and insuring a straight cut as well as making high speed possible.

At the same time the side head comes in and faces off the hub lining so that no extra time is required for this work. It makes a neat way of handling work of this kind.

Babbitting Crossheads.

They have the simplest form of babbitting jigs, as shown in Fig. 2, I have seen and they do the work in good shape. They depend on the faces XX of the crossheads C, being planed alike in all cases so far as the distance from one guide to the other is concerned, as well as being the same width on the outside. This allows the fixtures or jigs to be held on the crossheads by the simple clamps, shown at the side, and the babbit fills the opening between the two, being retained at the bottom by an asbestos sheet or pad on which it rests. The crossheads are tinned beforehand, being heated by an oil torch for this purpose.

which carries the two centre heads I and J. The arbor A carries the cutter K and is supported between the centres as shown.

A worm wheel W is secured to the centre in head I and by turning the wheel by the handle and worm the arbor and cutter are revolved on the centres. By removing collar C and putting on a grooved pulley the arbor can be revolved from a shaft overhead.

By the use of jigs in place of the centre head, different small jobs of grinding can be done.

OVERHEAD RUNWAY.

By J. S. Staveley.

For quickly transporting goods patterns, castings, etc., the accompanying sketches show a convenient method of building an overhead runway. Fig. 1 shows the arrangement of the posts, which are "halved" at the point where they cross each other and a plate coach-screwed on the top to take an 1 1/4" bolt which supports the carrying beam.

In order that the C.I. wheels of the "runner" can traverse freely, a 2" x 3/8" flat is screwed to the top of the beam,

the heads being countersunk. Where it is necessary to join the beams, the type of joggle joint suitable is also shown.

In Fig. 2 is seen the runner complete, with swivel ring bolt at the bottom. This is convenient for attaching the pul-

plicates. Attached to the double-armed leader C is a stud upon which is mounted a loose sleeve which travels in, and fits the slot of the templet. As the head is driven along the rail the tool is automatically raised or lowered accord-

right in London, with employes of the Dennis Wire & Iron Works Co., Ltd., as pupils. If the true "German Peril" be, as claimed, in the struggle for industrial supremacy, this firm is doing its part to avert it.

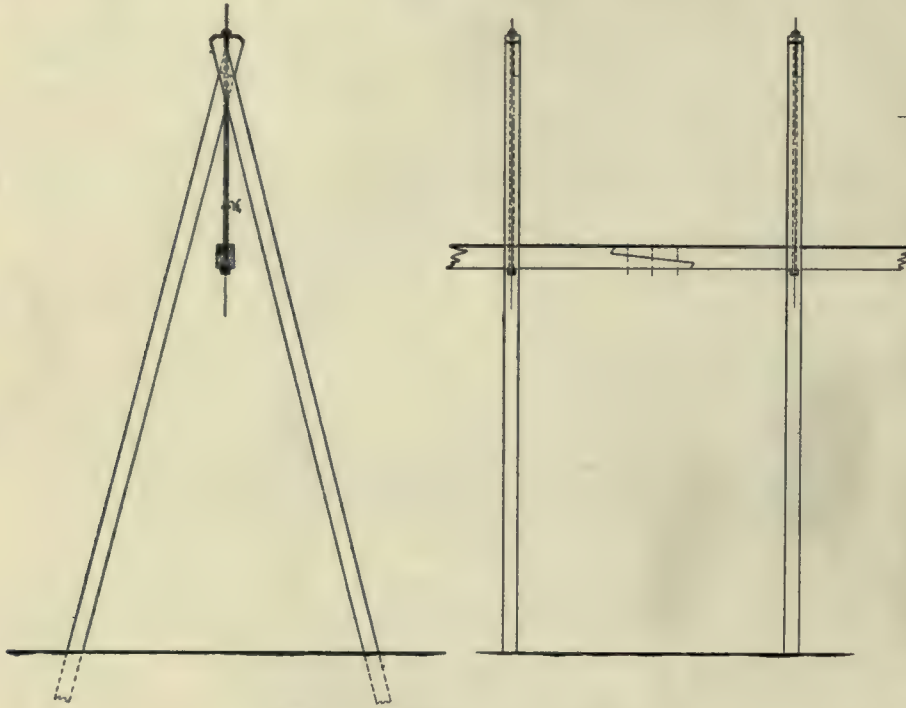

Fig. 1.—Arrangement of Posts.

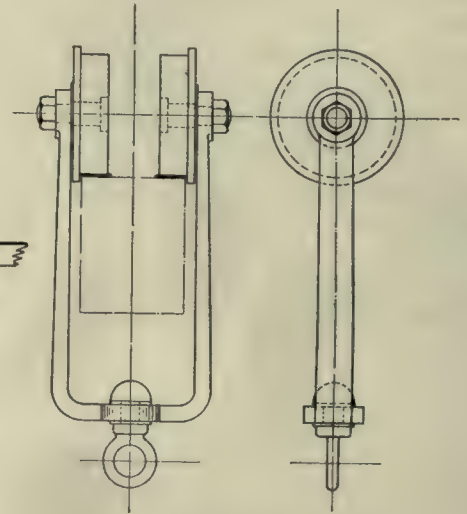

Fig. 2.—Runner Complete.

ley block, and adjusts itself to the direction of pull. It is well to rivet over slightly, the nut ends of the wheel spindle, to prevent them slacking off.

PLANING CURVED SURFACES.

An attachment for planing work of a convex or concave shape is shown in the accompanying engraving. The attachment consists of four parts all of which are of cast iron. These castings comprise the two side pieces or brackets A, the templet B, and the double-armed "leader" C, which is attached to the tool slide. Of course, different templets have to be used for different jobs, the shape of each being governed by the special requirements of the work in hand. The side brackets must be cast with bosses to allow the templet to clear the planer head, so that the latter can move along the rail. As shown, the brackets fit over the top guide on the rail and any slack is taken up by the set-screw shown in the end view. Separate pieces are fitted to the bottom of each bracket which are put in place after the fixture is put on the rail. These brackets are at all times stationary. The templet is worked out on a profiler or slotter, and it is attached to the brackets A by bolts. It should be machined carefully to the required shape, for, obviously, when it is made it will produce any number of pieces which will be exact du-

ing to the formation of the guiding slot in the templet. Of course, when this attachment is in use, the screw of the slide is removed. The fixture is entirely automatic, and when it is in use the cross-feed may be put on, and the planer will take care of the work. This fixture is not new, but there are doubtless many who are not familiar with it.—Machinery.

TECHNICAL EDUCATION IN LONDON.

By W. E. Elliott.

While slow-moving Governments and college faculties are talking of the need for technical education, private enterprises has initiated a modest trade school

One hundred men are employed in the Dennis works. Between 25 and 30 have already enrolled in a night class for training in the higher elements of the work in their own factory, and the company has provided a room in the upper part of the works for theoretical instruction.

Here are workmen who make first-class material. Here, also, are a few capable of acting as instructors. Machinery and other equipment is to hand as no trade school has it, with regard to the particular work in which Dennis employes are interested, and the management figure out that the least they can do is provide facilities for those who are ready to be taught.

"The men get their manual training in the day time," says Mr. Earnest B. Dennis, managing director; "and now we are prepared to give them the theoretical part at night."

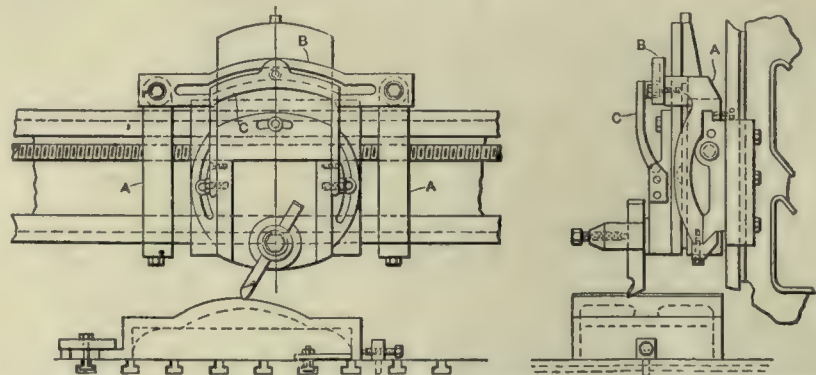

Planer Attachment Which Automatically Guides Tool in Planing Curved Surfaces.

Mr. Dennis' idea is to secure Inspector-Peake and others from Toronto, as well as local experts, to give lectures to the men, from time to time—lectures of Canadian Club quality and Dennis practicability.

"For some time my hobby has been technical education," said Mr. Dennis. "About two years ago I brought the matter up in the Board of Trade, but nothing was done.

"We get good men from England, and also a few from Germany. Some people speak disparagingly of the Englishman, but I tell you they can deliver the goods, thanks to trade schools.

"I have changed my mind about technical schools. I believe now that trade schools are the thing. At Detroit they have the best Y.M.C.A. in the United States. You go in there and find a great plumbing shop, with men making joints and all that sort of thing. They have another big electrical room with dynamos, meters, rheostats, etc. Then they have drafting and carpentering rooms. These things help a man make his living.

"We have the equipment right here for working in iron, and training will make our men worth more to us, and we will pay them more.

"We have a draughtsman whose father and grandfather before him were architects, and he was brought up in a technical institute himself. He is capable of showing these fellows."

In 1876, Mr. Dennis points out, an exposition was held in Philadelphia, and the German Government, always watchful, sent a commission over to see how German students and manufacturers stood, as compared with other nations, as shown by the exhibits. They went back and reported that England and the United States were far in advance. Then the Germans, being practical people, appointed another commission to find out ways and means of remedying the situation. They said, "If you want to manufacture good stuff you have got to have good men, and we need training schools," and so arose the present system of technical education in Germany.

"That was in the neighborhood of 30 years ago," remarked Mr. Dennis, "and now Germany has the most highly organized industrial plants in the world. We have a German manager in our Toronto branch. He is an engineer. 'You talk about militarism in Germany,' he will tell you, 'but it is not militarism—it is law and order, in the business and the home. Everything is done with precision.'

"We had a \$10,000 contract for ornamental iron work for a technical school in Quebec," added Mr. Dennis. "If they need one down there, surely we need one in London. A manufacturing concern cannot run ten minutes without labor, and intelligent labor is what we want. We have good material here, if we can only educate them a bit.

"It is awful, you know, when people come in here and ask for a job. I say, 'What can you do?' and the answer is, 'O, almost anything.' When I ask, 'Blacksmithing? Machines? Iron work?' they can do none of these. In this country there is nothing along this line between the public school and the college."

COMBINED ANGLE PLATE AND V-BLOCK.

By G. A. Beaudry.

This device I designed and built for use in my work of die making. The new feature about the tool is the arrangement by which a short screw is used. This short screw will clamp all the dif-

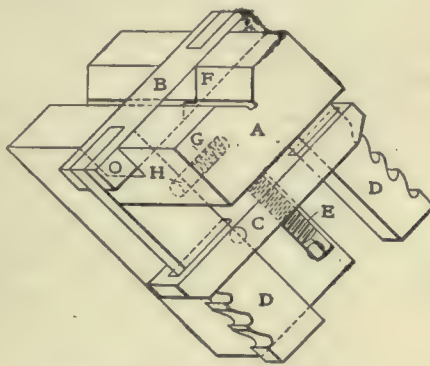

Combined Angle Plate and V Block.

ferent sizes which the tool can take in, that is, from 1/4-inch up to 4-inch, round or square stock.

A is the body of the tool proper; B is the clamping bar into which a V is cut to correspond with F (the V in the body) and it can be moved forward or back according to requirements. D D are side bars into which are cut a certain number of teeth which catch the ends of the binding bar C and when the screw E is set up against the body A and forces the bar C backward, bar B is pulled back and clamps the work. To move bar B forward take parts D D between the thumb and forefinger and press them together; this releases binding bar C and allows it to be pulled backward and then bar B can be pulled forward so as to admit the stock. G is a coil spring and H is a pin set in the body A on each side to force rods D apart so that they catch on the ends of binding bar C; then a few turns of screw E will clamp the work solidly.

This appliance can be clamped on the table of a drill press or on the face plate of a lathe or grinding machine.—American Machinist.

A CO-OPERATIVE SYSTEM.

In the year 1825, Charles Allen, a native of Andover, Vermont, settled in Waterloo, Que., and there worked as a blacksmith. A few years later he formed a partnership with Daniel Taylor, a native of Newfane, Vermont, to carry on the business of blacksmithing and cloth dressing. That partnership continued until 1858, when Mr. Taylor died. In 1861 a new partnership was formed, and a son of each of the former partners was admitted into the company. Charles Allen died in 1881, and his second son became a member of the company.

This firm is still carrying on the business of machinists and dealers in general merchandise, their general store being started by them in 1839.

D. L. Allen commenced working as clerk for Allen, Taylor & Co., in 1861, and was admitted a partner in 1881. The general merchandise business has been carried on in the same store for seventy years.

The Waterloo (Que.), Iron Works, the manufacturing end of the company's interests was started by Charles Allen as stated above. The works have been in continuous operation eighty years. The works and the store are now being conducted by the third generation with the exception of D. L. Allen, who is of the second generation.

Owning both works and store, it is an easy matter for these two institutions to work together. The employer and employe exchange work for merchandise, the co-operative system followed being very simple. It is not compulsory for a workman to deal at the general store of Allen, Taylor & Co., but it is made very easy for him to do so.

If a workman decides he will deal with the company for whom he works, he is furnished with a pass book in which is entered the purchases made at any time. At the end of the week the pass books are checked up. The amount of purchase is treated as an advance payment, and is deducted from the total wages due the workman. The balance due him is placed in his envelope. The system is found to work satisfactorily and is beneficial to both workman and proprietors.

Correspondence

Readers are invited to send in replies to answers asked under "Correspondence," and these will be paid for at regular editorial rates. Anyone desiring the names of firms manufacturing certain lines will be answered under this heading. Comments on previous articles containing good ideas will be paid for.—Editor.

Position of Belt Tightener.

Will a reader please inform me the proper place to put tightener on a main driving belt, as shown in the illustration.

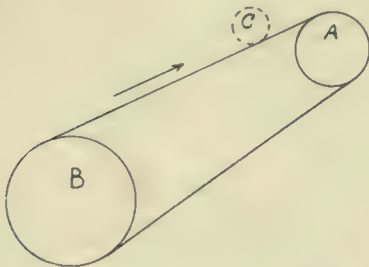

Where Should the Tightener be Placed?

A is the driven pulley on line shaft. B is the driving pulley on the engine. The arrow shows the direction in which the belt runs.

CENTRE PUNCH.

The dotted circle C shows the suggested position for the belt tightener. In addition to tightening belt, it will give a larger belt contact on the small pulley if placed close to it.—Editor.

* * *

Boring Deep Holes.

I have some castings in which deep holes must be bored, and I find it very inconvenient. Are there not some methods for boring, without having to withdraw the drill every few turns to remove the cuttings?

SUBSCRIBER.

In the Feb., 1908, issue, Canadian Machinery, is an article on this subject by John Edgar. Hollow drills may be obtained from the manufacturers of twist drills advertising in Canadian Machinery, and it is comparatively a simple matter to use a hollow drill and lubricate the work. One method is to attach a hollow tube of less diameter than the hole. Feed in the lubricant through the centre and the chips will be carried out along the fluted sides and out along the outside of the hollow tube.

If the work to be bored is firmly chucked and runs true in a rest, and the

boring bar is held rigid in the lathe rest, great accuracy may be obtained.—Editor.

* * *

Rust on Metals.

We store away iron and steel, but as the storehouse is a little damp the bars rust. Will you recommend a preventative for rust—READER.

Answer—A coating of sperm or lard oil will prevent rusting. Do not use lubricating oil. A box of lime placed near the steel will absorb dampness.—Editor.

* * *

Lignum Vitae.

Where is lignum vitae obtained.

B. C. SUBSCRIBER.

Guaiaicum, Brazilwood, or lignum vitae is obtained in the American tropics, and is remarkable for the hardness and heaviness of the wood. We would appreciate receiving the address of a Canadian or United States company handling lignum vitae.—Editor.

* * *

Vulcanizing Rubber Tires.

How can I vulcanize automobile rubber tires so that after vulcanizing the rubber will again be brought to its normal elasticity. I find that after I heat the rubber to its melting point, it is completely spoiled, and the reason is probably because I am not using the right process. Will a reader of Canadian Machinery give the correct method through this paper.

MILDMAY.

* * *

Tempering Gears.

In the March issue of Canadian Machinery a manufacturer asked for a safe, simple method for hardening the teeth of steel cut gears to prevent warping.

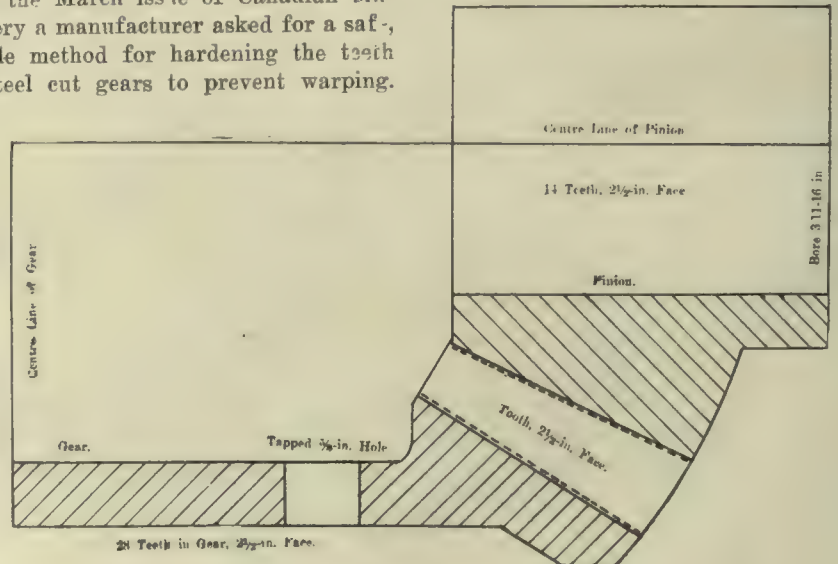

Gears to be Tempered.

Herewith is given a sketch and suggestion for hardening them will be appreciated and paid for. The teeth are to

be hardened one-sixteenth of an inch on the surface. There is no furnace in which the gears can be placed, except a small brass furnace, which has a diameter of about 15 or 16 inches. It is necessary that these gears run perfectly true, as they run at high speed.

* * *

British Locomotives.

Are there any locomotives of British manufacture running on the railways of Canada. I understand there are some Scotch locomotives in Lower Canada. Will readers please send this information.—C. E.

5th ANNUAL BANQUET OF G.T.R. APPRENTICES.

An excellent toast list was provided at the fifth annual banquet of the Grand Trunk apprentices, Stratford, on March 15, and the addresses given were listened to by nearly all the members of the club and their friends.

The toast to the "G. T. R." was responded to by Master Mechanic, J. G. Markey, Toronto; "The Local Shops," W. Seeley, and "The City," by Mayor Dingham and W. Preston; "Apprentices," W. Margett, "Ex-apprentices," E. R. Dalley.

Prof. Angus, of Toronto University, was on hand, and replied to the toast of "Educational Facilities," as did Principal Mayberry and W. Walton. "Our Teachers," by E. Meldrum; "Visiting Apprentices," L. Andsky, P. Drummond and E. Thorpe, of Montreal; "Athletics," H. Humber, and "The Ladies," H. Walton.

The Grand Trunk band discoursed

several selections, and solos were rendered by J. G. Sarvis, H. Genson, A. Kelso, W. Bryanston and A. Walton.

POWER GENERATION ^A_D APPLICATION

For Manufacturers. Cost and Efficiency Articles Rather Than Technical.
Steam Power Plants ; Hydro Electric Development ; Producer Gas, Etc.

BELTING OF HALF COTTON AND HALF LEATHER.

In a discussion of lineshaft efficiency in the proceedings of the American Society of Mechanical Engineers, W. F. Parish, Jr., points out that for comparative tests made under work-shop conditions it is advisable to have the belts made up half of cotton and half of leather, thereby eliminating the effect of humidity, which may cause variations of 12 per cent. in the power delivered.

An English firm five years ago purchased a cotton belt to drive a dynamo, but this belt was not equal to the speed and power required of it, so a leather belt was substituted. It was decided to use the cotton belt on one of the main mill drives, but it was found to be much too short. So a piece of leather belt was spliced in, the whole being, when finished, half leather and half cotton. A casing was built under it, as it was low down and in a dangerous position. The manager was annoyed to find that this casing had been built too close to the belt, no allowance being made for sagging.

The dampness greatly affected the leather belt, as the drive was in a low part of the mill, but the casing under the patched belt was never altered. The length of the belt never varies whether the weather is damp or dry, and it is the best belt drive in the mill for steady work. Moisture has an opposite effect on leather and cotton, leather lengthening and cotton contracting with an increase of humidity, so that in the half-cotton and half-leather belt the weather effect is practically compensated for.

VACUUM CLEANERS IN INDUSTRIAL PLANTS.

The vacuum cleaner has been developed with much aggressiveness by its various builders, and has now become of recognized utility in industrial as well as residential life. The modern shop and factory are well ordered institutions, and cleanliness is a prime requisite.

The vacuum cleaner is a most complete remover of dust and dirt and finer debris of all sorts. The vacuum system of cleaning promises exceptional usefulness in ridding works of those kinds of dust which are injurious to the health of employes. The manufacturers believe that they can be of great service to factories

which do wet grinding, by collecting the dried sediment of particles of abrasive and metal.

Where an exhaust system is installed, the apparatus is designed to be attached at conveniently spaced stations. The self-contained unit, with an electric motor attached to the fan, can be employed in any works having electric wiring. The blower and exhaust have a great usefulness, extending over a wide field. The vacuum cleaner is an addition to the scope of effort, which will undoubtedly be adopted quite generally in the next few years.—Iron Age.

HOME MADE ERECTING CRANE.

By Charles Collins.

Recently I happened to be where a new light and power plant was being installed. As the parts of the machines were cumbersome and heavy to handle the erecting crew were provided with a

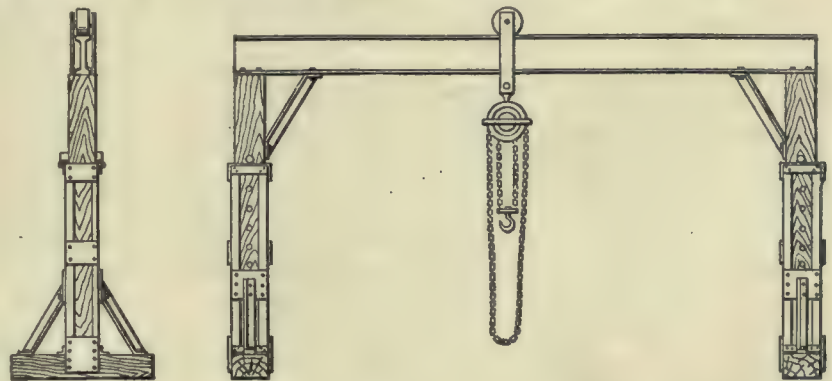

HANDY HOMEMADE ERECTING CRANE.

light and handy portable traveling crane of home-made construction, which seemed to be the acme of convenience.

It consisted of a ten-foot length of I-beam supported by two 6x6-inch timbers, which telescoped into light, well braced frames of angle iron, thus permitting the beam to be raised to a height suitable for the job. A traveler and a chain tackle completed the outfit.—American Machinist.

POWER TRANSMITTED BY BELT.

By H. D. Chapman.

The power transmitted by a belt is directly proportioned to its speed. A safe rule is:

Allow one h.p. for a speed of 1,000 feet per minute, with a belt of single thickness, 1 inch wide.

This is a more liberal allowance in favor of the belt than is usually given,

but will increase its life in far greater proportion than the increase in first cost.

Double belts will transmit about 1½ times as much power as single belts.

This rule applies to belts running over pulleys of equal diameter, or where the arc of contact is 180 degrees. For smaller arcs of contact, use the coefficients found in the following table:

Deg.	90	100	120	130	140	150	160	170	180	200
Coef.	0.65	0.70	0.75	0.79	0.83	0.87	0.94	0.97	1.00	1.00

To increase the power transmitted, either increase the speed of the belt by using larger pulleys, or use a wider belt.

Example. A 3-inch, single belt is running over a 24-inch driving pulley, which makes 200 revolutions per minute. How many h.p. will it transmit?

The circumference of the pulley in feet is $2 \times 3.1416 = 6.2832$ feet.

As the speed of the pulley is 200 revolutions per minute, the speed of the

belt will be $200 \times 6.2832 = 1256.64$ feet per minute.

For every inch of width it will transmit $1256.64 \div 1000 = 1.25664$ h.p.

Then, a 3-inch belt will transmit

$3 \times 1.25664 = 3.76992$ h.p.

If it is desired to increase the power in the above example to five h.p., it may be done by using a wider belt in the proportion of 3.75 to 5, or in reality a 4-inch belt. The same thing could be effected by increasing the size of the pulley in the same proportion, or

$$3.75 : 5 :: 24 : 32.$$

It would thus require a 32-inch pulley. A double belt of the same width would transmit 1½ times as much power or $1.5 \times 3.75 = 5.63$ h.p., which would be a little more than the required five h.p. — Power.

CANADIAN MACHINERY

AND MANUFACTURING NEWS

A monthly newspaper devoted to machinery and manufacturing interests mechanical and electrical trades, the foundry, technical progress, construction and improvement, and to all users of power developed from steam, gas, electricity, compressed air and water in Canada.

The MacLean Publishing Co., Limited

JOHN BAYNE MACLEAN, *President* W. L. EDMONDS, *Vice-President*

H. V. TYRRELL, Toronto Business Manager
G. C. KEITH, M.E., B.Sc., Toronto Managing Editor
F. C. D. WILKES, B.Sc., Montreal Associate Editor

OFFICES:

CANADA	UNITED STATES
MONTREAL - Rooms 701-702 Eastern Townships Bank Bldg	NEW YORK - R. B. Huestis
TORONTO - 10 Front Street East	1109-1111 Lawyers' Title, Insurance and Trust Building
WINNIPEG, 511 Union Bank Building	Phone, 1111 Cortlandt
Phone 3726	
F. R. Munro	
BRITISH COLUMBIA - Vancouver	FRANCE
H. Hodgson,	PARIS - John F. Jones & Co.,
Room 21, Hartney Chambers	31bis, Faubourg Montmartre,
	Paris, France
GREAT BRITAIN	SWITZERLAND
LONDON - 88 Fleet Street, E.C.	ZURICH - Louis Wol
Phone Central 12960	Orell Fussli & Co
J. Meredith McKim	

Cable Address:

Macpubco, Toronto. Atabek, London, Eng.

SUBSCRIPTION RATE.

Canada, United States, \$1.00, Great Britain, Australia and other colonies 4s. 6d., per year; other countries, \$1.50. Advertising rates on request.

Subscribers who are not receiving their paper regularly will confer a favor on us by letting us know. We should be notified at once of any change in address, giving both old and new.

Vol. VI. April, 1910 No. 4

TARIFF AGREEMENT.

Much to the satisfaction of the people of United States and Canada, a tariff agreement has been amicably arranged. Canada has conceded lower duties on thirteen items, and in return receives the benefit of the United States minimum tariff. The items cover food stuffs such as dates, figs, nuts of all kinds, etc; soaps, toilet preparations, window glass, watch actions, feathers, etc. The reduction amounts from about 2½ to 3 per cent.

In connection with the tariff arrangement, there is a reciprocity offer, President Taft proposing negotiations looking toward the establishment of closer relations between United States and Canada. Any movement in the direction of broader and closer commercial relations will receive the hearty support of the large majority of the people of these two countries.

Canadian manufacturers are in hopes that when the representatives of the two countries meet, the subject of reducing the tariff on machinery not made in Canada should be considered. At the present time there are a great number of machine tools not manufactured in Can-

ada and Canadian plants are at a disadvantage on account of the high initial outlay necessary when certain machines are required.

Take the automatic for example. The machine costs probably \$1,500, f.o.b. place of manufacture. The duty is 27½ per cent., bringing the total cost up to \$1,912.50. This includes only one set of tools and many are required which the user must make himself at great risk of inaccuracies on account of all toolmakers not being familiar with the automatic. Otherwise, he must pay heavy duty on the necessary tools. We have not considered the freight in the above figures.

It is manifestly unfair to place the Canadian manufacturer at such a decided disadvantage in regard to shop equipment, when the machines cannot be obtained in Canada. This applies not only to automatic machinery, but to cylindrical grinders, gear cutting machinery and numerous others. If the Canadian manufacturer is to be the factor in the world's market that he should be, he should receive all the assistance possible to compete with other manufacturers placing similar lines on the market.

ONTARIO BOILER LAW.

For a number of years manufacturers and users have been working towards the adoption of uniform boiler regulation in the various provinces. At a meeting in Regina in December, 1909, representatives of the various provinces met and discussed regulations which would be acceptable to the several provinces.

At the recent session of the Ontario Legislature a bill was passed respecting steam boilers. As the bill states, the regulations shall come into force at such a date as is deemed advisable. The following are the provisions of the Ontario Boiler Act:

1. This Act may be cited as "The Steam Boiler Act."
2. In this Act "steam boiler" shall mean a boiler used for generating steam for heating and power purposes, and every part thereof or thing connected therewith, and apparatus and things attached to or used in connection with any such boiler, but shall not include a boiler used for heating water for domestic purposes or a railway locomotive or steamboat boiler.
3. Upon the recommendation of the Minister of Public Works the Lieutenant-Governor-in-Council may make such rules, regulations and specifications as may be deemed proper respecting the construction of steam boilers, including the materials to be used, the method of construction, the tests to be applied, the inspection of the boiler during its construction and before it is permitted to leave the place of construction, and generally such other matters as may secure a uniform standard of strength, safety and efficiency.
4. The rules, regulations and specifications shall be published in the Ontario Gazette and shall come into force and take effect at a date to be named by proclamation.

MR. FOSS AND RECIPROCITY.

The election of Eugene N. Foss to the United States Congress marks a long step towards securing fair trade between United States and Canada. Reciprocity has been a hobby of Mr. Foss' for years and his policy, "Canadian Reciprocity and Tariff Reform," has won for him a notable victory in a constituency which had always voted Republican.

E. N. Foss is president of the R. F. Sturtevant Co., Boston, whose blowers and ventilating apparatus are known the world over. Mr. Foss' creed is thus summed up :

"Reciprocity with Canada is not a question of a year or a day. It is one for the statesmanship of the future, and it is to the interest of both countries to have this question settled intelligently and upon broad lines, which will permit to both countries the highest development of all their resources. Reciprocity accomplished, contemplates the extension of American conditions to Canada. These have made the United States the most prosperous country in the world, and they will make a prosperous Canada."

Mr. Foss' victory should go far in bringing about the realization of his creed.

CANADA'S GROWING TRADE.

The total trade of Canada for February, 1910, was \$46,291,201, an increase of \$8,202,374 over February of last year.

For the eleven months of the fiscal year the total trade has been \$610,577,981, an increase of \$104,113,307, or over 20 per cent., as compared with the corresponding eleven months of the last fiscal year, and constituting a new record for Canadian trade.

Imports for the month totaled \$30,341,462, an increase of \$7,152,794. For the eleven months the imports totaled \$332,391,669, an increase of \$68,131,239.

Exports of domestic products for the month totaled \$15,337,043, an increase of a little over one million. Exports of domestic products for the eleven months totaled \$257,012,262, an increase of \$32,805,650. Of this latter increase, about seventeen millions was in agricultural exports, about seven and a half millions was in exports of the forest, and about two millions in exports of manufactures.

Exports of foreign products for the eleven months totaled \$21,174,050, an increase of a little over three millions.

The total customs revenue for the eleven months was \$53,781,333, an increase of \$11,389,085.

The monthly financial statement of the Dominion shows an increase of \$1,606,751, as compared with February, 1909, and an increase of \$14,179,638 for the first eleven months of the present fiscal year, as compared with the corresponding period of last year. The total revenue for the eleven months has been \$89,684,460. When the books

are finally balanced for the year it is expected that the revenue will run very close to the hundred million mark, and will exceed by a million or so Hon. Mr. Fielding's conservative estimate in his budget speech of December last.

The expenditure on account of consolidated fund for the eleven months has been \$63,876,584, a decrease of \$3,127,898. On capital account the expenditure has been \$29,989,535, a decrease of \$9,312,567.

The net public debt at the end of February was \$328,658,879, a decrease during the month of \$1,211,090.

GOOD TIMES AT CANADA FOUNDRY.

"I have been authorized to announce that, dating from March 1, 1910, a general increase in wages of five per cent. will be made to all the works' employes of the Canada Foundry Co., Limited, who are on an hourly basis.

"The management recognize the harmony that has existed between themselves and the employes during the dull times, and take the earliest opportunity afforded by improved prospects of showing their appreciation in a practical manner."

This is the notice which the 1,000 employes of the Canada Foundry Co. saw posted in the works on March 1. The total amount of wages affected upon which five per cent. increase will accrue will be between \$12,000 and \$13,000 weekly. The increase means, therefore, \$600 or \$650 a week.

This action in asking the employes to share in the prosperity the company has enjoyed is an encouraging sign of the times, indicating, as it does, the hopeful view the directors of the company take in the future. It augurs well for the cordial relationship between employer and employes. Having a reputation for fair dealing with employes or customers is one of the greatest assets a company can possess.

CANADIAN MACHINERY IN THE WEST INDIES.

It will, no doubt, be of interest to our thousands of Canadian readers, that mechanical men in the West Indies are also interested in the Canadian Machine Shop and Foundry paper. David Williams, one of the best known of our large staff of circulation representatives, has been visiting the West Indies for the past three months, and he writes that Canadian Machinery is taking well among the reading class of mechanical men, and that all appear anxious to keep in touch with Canadian practice.

Writing from British Guiana, Mr. Williams reports securing fifteen subscribers to Canadian Machinery, as a result of his first few days' work there. He will remain some time yet in the West Indies and British South America in the interests of the MacLean papers. What is being done in the south is being done in Canada.

Three new salaried circulation men started work on the MacLean papers on April 4, in addition to a number of local shop agents. It is the intention of the MacLean Publishing Co. to keep pace with Canada's industrial growth, and this can only be done by increasing the staff. As soon as capable men can be secured other additions will be made to the circulation staff.

DEVELOPMENTS IN MACHINERY

New Machinery for Machine Shop, Foundry, Pattern Shop, Planing Mill; New Engines, Boilers, Electrical Machinery, Transmission Devices.

SLOTING ATTACHMENT.

There are many times when a slotting attachment can be used to advantage on a milling machine. This is especially true of the tool room miller, as much time can be saved on slotting boring bars, dies, wrenches, internal gears, keyseating, etc.

In the attachment illustrated herewith, the adjustment of stroke is easily effected. The ram is a rectangular steel bar carrying at its lower end hardened V-jaws in which to clamp the slotting tool.

The tool can be of any form or shape, rough or finished. The form of ram permits of a long bearing relative to its width which ensures rigidity and alignment.

The cutting stroke is one half the speed of the return, greatly increasing the output. The ram can be swiveled through the entire 360 deg., making it possible to hold work in the chuck on the dividing head in a horizontal position and cuts taken, using the head for indexing on such work as a hex socket wrench, internal gears or anything of this character that cannot be done accurately by other means.

The return is effected through the driving shaft which has a T-slot cut through its front end to receive the adjustment bolt. This bolt is adjusted

with a wrench, an opening being provided for this on the right hand side. Adjustment of stroke is provided from 0 to 4 inches.

The driving shaft has a groove in which is fitted a bronze block that is

to give a quick return of two to one as before mentioned.

Milwaukee Milling Machines are all constructed with the knee slide carried upward to the over-arm, the primary object being to securely hold attachments such as this.

The attachment could be used in connection with rotary table, as shown by photographs for any work requiring slotting and indexing as, for instance, internal gears or anything of that nature. It can also be swiveled to a horizontal position and used in connection with universal centres for similar work where rotary table is not available.

The oil tubes for conveying lubricant to the cutting edge are regularly supplied on all of their milling machines, none being made without them.

The details are shown in Fig. 3. The ram A is a rectangular steel bar, and carries at its lower end V-blocks BB, with a hardened piece C to back up the tool. The tool D can be of any form or shape, rough or finished. This form of ram permits of a long bearing relative to its width, which insures stiffness and better alinement.

The return of two to one is effected through the driving shaft E, which has a T-slot cut through its front end to receive the adjustment bolt, F. This

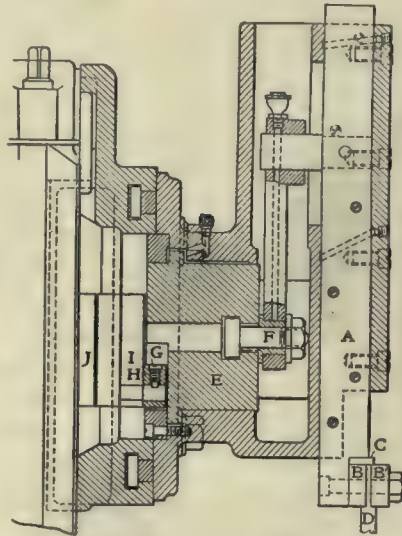
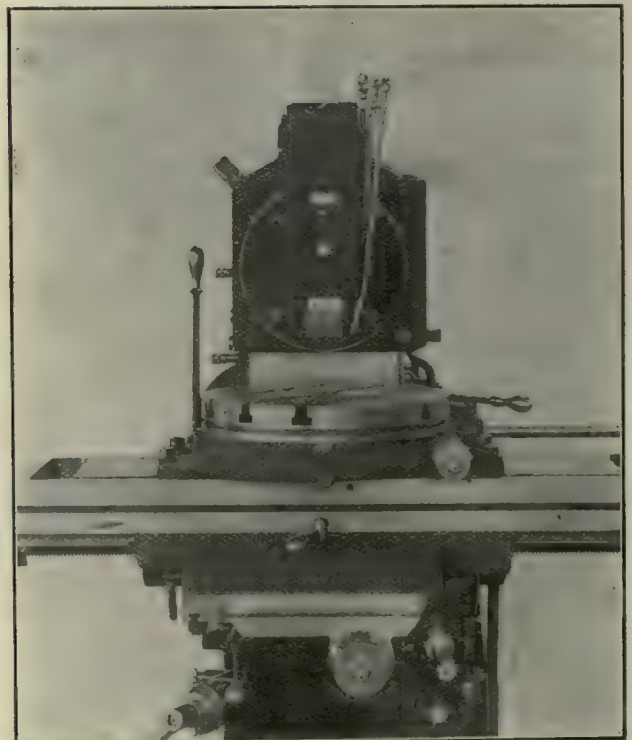

Fig. 3.—Details of Slotting Attachment.

driven by a collar directly on the main spindle of the machine. The centre line of the driving shaft is above the centre line of the spindle, a distance sufficient



Slotting Attachment on Kearney & Trecker Milling Machine. Fig. 2.—Slotting Attachment on Kearney & Trecker's Milling Machine.

bolt is adjusted with a wrench, through an opening on the right-hand side.

The driving shaft E has a groove GG, carrying a bronze block H, that is driven by the collar I directly on the main spindle of the machine. The centre line of the driving shaft E is above the centre line of the spindle J, a distance sufficient to give the quick return.

These milling machines are made by the Kearney & Trecker Co., Milwaukee, Wis.

UNIVERSAL MILLING MACHINE.

The new style Universal Milling Machine illustrated herewith shows several changes in design including the feed box, the dividing head and changes in the machine. The photos show the large proportions of all the main parts and an unusual design for simplicity and rigidity.

The automatic feeds to the table are transmitted from the spindle through a roller chain to the sprocket wheel of the feed box. On the sprocket shaft rides a sliding gear on which are mounted two other gears; these gears are shifted by means of the lower lever on feed box, so as to engage other gears which are secured to the intermediate shaft. On this intermediate shaft are also secured a cone of gears into any one of which the intermediate tumbler gear is engaged. From the tumbler gear shaft the power is transmitted through the universal joint to the gears on the knee and there the automatic longitudinal, cross or verti-

cal feed is engaged. The gears in feed box run in oil, provisions are made so as to readily drain the oil and put in clean oil. A direct reading index plate is attached to the feed box from which

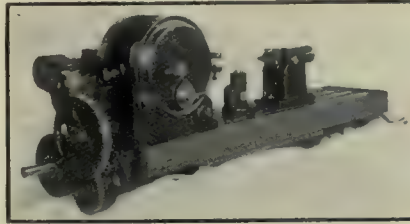

Fig. 3.—Details of Dividing Head.

the exact amount of feed per revolution of spindle is read.

The elevating screw is provided with ball bearings which insure ease of operation. This screw does not extend below base when at its lowest point.

The nose of the spindle is slotted to

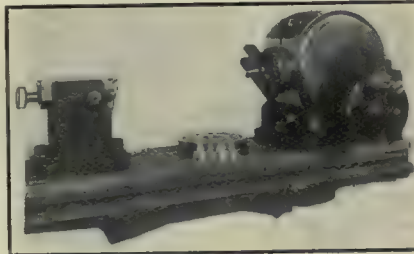

Fig. 4.—Details of Dividing Head.

positively drive arbors and other tools.

The universal head is designed for dividing work in any position from 10 degrees below the horizontal to 10 de-

grees beyond the perpendicular. It is furnished with dividing mechanism for spiral cutting and has several noteworthy features.

This head can be securely clamped in any position by two bolts with V-blocks, turned to the same radius as the V on body, which are such a distance apart as to make it very rigid.

The dividing crank is fitted on the worm shaft, thus eliminating the gearing when used for dividing. A half turn of the engaging crank disengages worm from wheel.

One of the features of this head is the quick spacing device to divide work in 2, 3, 4, 6, 8, 12 and 24 divisions. The spindle spacer consists of 24 holes drilled in the worm wheel and the front shoulder of spindle has 24 graduations in plain view, which graduations are in line with holes in worm wheel. The spindle spacer pin is hardened and the point is tapered, it is actuated by a crank.

The worm shaft and worm are made in one piece of tool steel, and the worm wheel is made of bronze.

To compensate for any wear that takes place between worm and worm wheel, there is provided an eccentric bush. This raises the engaging crank and consequently the worm.

When using the universal head for dividing work the sleeve and plate are held stationary by locking the sleeve to trunnion.

The spindle can be very efficiently clamped by a wedge pin with a 60 degree angle milled on one end to fit 60

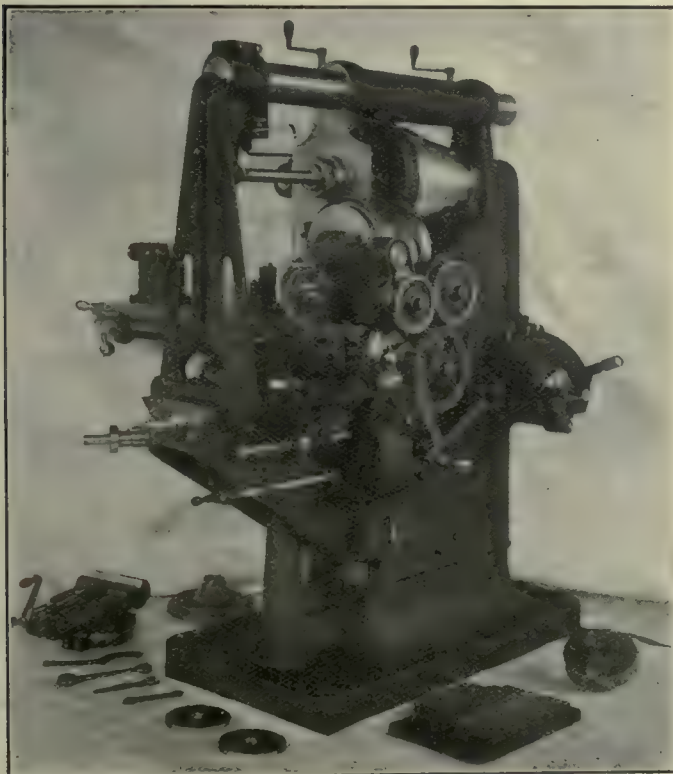

Fig. 1.—Oesterlein Milling Machine.



Fig. 2.—Oesterlein Milling Machine.

degree groove turned in spindle. This wedge pin is operated by the screw shown in Fig. 3. The crucible steel spindle has a taper bearing its entire length and any wear is readily compensated by means of a split nut on back of spindle.

To rotate the work for spiral cutting connection is made to the lead screw by gearing shown in Fig. 3.

With this head goes a complete set of change gears, three dividing plates, a tailstock and centre rest. These 3 plates will index all divisions up to 100, all even and those divisible by 5 up to 200 and many others.

The plain head shown in Fig. 4 is the standard head for plain milling machines. It will do all work the universal head will, except spiral cutting.

The tailstock is so arranged that it can be swiveled to any angle necessary for milling taper work. It has an efficient clamping device for the centre.

This Universal Milling Machine is made by the Oesterlein Machine Co., Cincinnati.

SELLS ROLLER BEARING.

The Sells roller bearing herewith illustrated and described is being sold by the Royersford Foundry & Machine Co., Royersford, Pa. It is the design of John D. Sells, for many years identified with the "Standard" roller bearing, and is therefore the product of a long experience in this line of work. This bearing is universally adaptable, can be applied to any hanger or pillow-block

The construction is as follows: First the split sleeve is put on the shaft. This is formed in two parts, with the split running diagonally, so that the rolls may pass over the joint without shock or irregularity of motion. Next this sleeve is clamped in place onto the shaft by two collars, which are provided with counterbores fitting the edges of the sleeve so that they are thus themselves truly located. Next the two halves of the split cage are placed around the sleeve between the collars. Then, as shown in Fig. 2, the box itself is put over the whole and fastened. The application of the bearing will thus be seen to be as simple as the application of a split sleeve or wood pulley.

The bushing is of hardened steel, and absolutely protects the shaft from being cut or scored by the case-hardened steel rollers. Injury from this cause is of common occurrence in other designs. These bushings are so constructed as to vary in thickness, allowing the same size of bearing to be fitted to different diameters of shafts. Each roller cage structure is adapted to three such changes of bushings. This makes it unnecessary for the dealer to carry a large stock of these bearings, as odd-sized bushings will take care of the intermediate sizes.

The rolls, as shown are contained within a roller structure or cage. This separates them from each other, and eliminates the friction caused by the rolls running in contact. It also holds them parallel to each other so that it

and to give further assurance in this matter a heavy felt wiper is used at each end of the box, which at the same time prevents the loss of oil. Drain holes are also provided so that the case can be flushed with kerosene or other cleansing fluid when the oil gums. Holes are tapped in the top of the box to provide for oil cups. For head or jack-shaft use, on shafts 3 11-16 inch diam. or larger, this bearing is provided with a double roller structure shown in Fig. 1. This gives a greater bearing area for heavily loaded shafts. All parts are made interchangeable. In case any part of the bearing becomes mislaid or broken by accident, it can be easily replaced, thus avoiding the expense of a new complete bearing. For the present the manufacturers intend selling these bearings at fifty per cent. less than that asked for any similar device on the market.

OIL AS AN AUXILIARY FOR OPEN HEARTH FUEL.

By G. P. Blackiston.*

The great shortage of the natural gas supply on the one hand and the frequent delays of coal deliveries on the other, due to severe cold weather as experienced this year, has made some of the slower thinking manufacturers realize the great necessity of being provided with some auxiliary method of heating. This is especially true in the open hearth practice, where a sudden shut off of fuel would often mean not only a delay but a total loss to both the furnace and its charge—the furnace being out of commission for many weeks at the least.

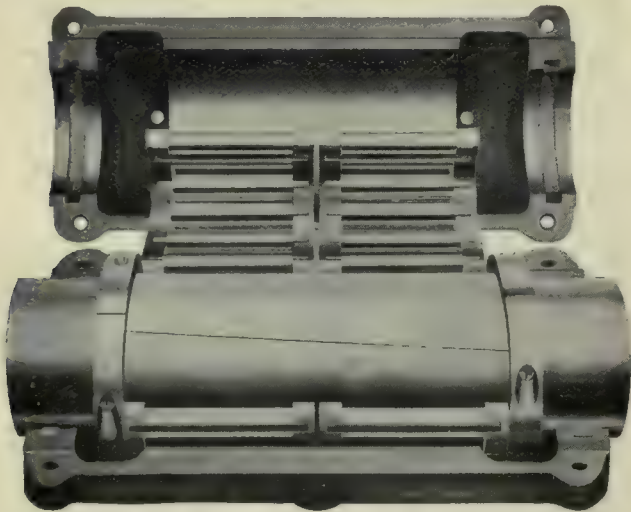

Fig. 1.—Sells Roller Bearing of Double Cage Type.

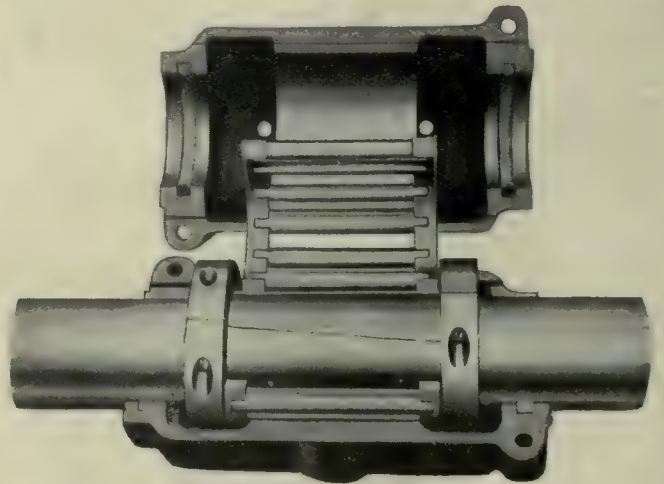

Fig. 2.—Sells Roller Bearing of Single Cage Type.

of corresponding size either for new installations or for substituting in a plant previously equipped with the old style of plain or oil bearings; and it also possesses the advantage of being applicable without requiring to be pushed on over the length of the shaft from one end to the other.

is impossible for them to get cramped diagonally in the boxes.

This bearing is of the full floating type, so that none of the customary trouble from end-thrust friction in roller bearings is met with. The two halves of the case are fitted together with milled joints to make them dust-proof,

This being the case, many of the largest plants have been equipped with an auxiliary heating system.

The problem has been, however, how to secure an equipment that would give

* Formerly Superintendent of Open Hearth Furnaces Howe-Brown Steel Co., Pittsburgh.

satisfactory results without necessitating any changes in the operation or construction of the furnaces—also one that would not interfere with the floor space and be capable of being installed in the narrow spaces between the ends of the furnaces.

After considerable experimenting a device was designed and placed upon the

ing the temperature to facilitate atomization and feeding it to the burner under a uniform pressure.

Oil is fed to the burner by this means under a pressure of from 35 to 50 lbs. and a small quantity of compressed air or steam for atomizing the oil is supplied at a pressure from 5 to 10 lbs. less than the oil pressure. Either steam or com-

absolutely minimized. Several of the largest plants in the Pittsburgh territory were thus spared this winter on more than one occasion.

COLLAPSIBLE STEEL HORSES.

S. M. Hildreth, 2 Rector St., New York City, are placing on the market a collapsible steel horse or trustle. They are made from angle iron and are very rigid. The legs fold up when the trestle is not in use. They are useful for carpenters, contractors, machine shops, manufacturing plants, etc.

MOTOR DRIVEN MULTI-SPINDLE DRILL.

A motor driven multi-spindle drill is shown herewith, the placing of the motor being of special interest. It is a vertical type, variable speed, 550 volt direct current motor, 12 h.p. 300 to 1,200 r.p.m. with ball bearings.

The drill is a six spindle drill for repetition work and is of substantial de-

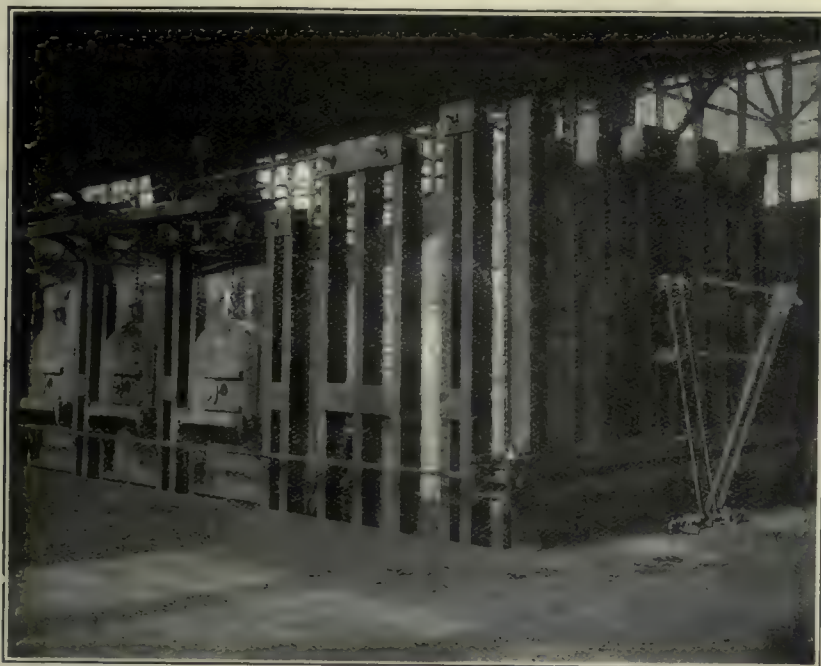

The Kirkwood Oil Fuel System as Applied to Open Hearth Furnaces.

market by Tate, Jones & Co., Inc., Pittsburgh, Pa., that fulfilled all the severe requirements. At either end of the furnace a burner is installed, each being properly mounted on a swinging stand located on exterior of furnace to admit of one burner being swung into place (into the parts of furnace), and the other swung out and turned off as the furnace is reversed. The design of the burner is such that the supply of oil and compressed air or steam for atomizing is regulated by one lever, the ratio between the atomizing agent and the oil always remaining at a constant point, which has been found to be the proper proportion for complete atomization.

This adjustment is scientifically made and fixed before the burner leaves the factory, so that an efficient fire is always maintained.

Necessary valves are provided on the burner stand for cutting off the oil and atomizing agent, when it is necessary to remove the burner from the stand. The oil and atomizing agent are controlled from the charging floor.

An oil pumping, heating and regulating system is also used for drawing the oil from the storage tanks, straining the foreign matter and lumps from it, rais-

pressed air may be used for atomizing, as determined by local conditions. The oil lines from the pumping system and the compressed air or steam lines are run to the charging floor where special controlling valves are provided, as indicated above, and the additional reducing valves are introduced in the air or



Throwing in Kirkwood Oil System When Gas has Given Out.

steam line for cutting the compressor or boiler pressure down as required.

The burners when not in use are thrown back (out of the ports), from the ends of the furnace. When the regular fuel supply gives out, one of the burners is merely thrown forward, and the valves on the regulating stand opened with a continuation of the melting.

By this method all danger of a shut down on account of shortage of fuel is

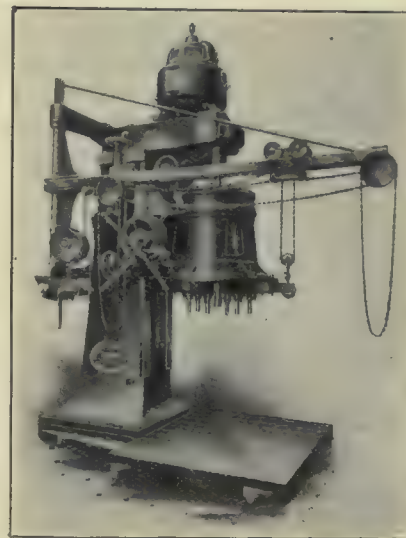

Vertical Type Motor Driving Multi-Spindle Drill.

sign and build, being one of Craven Bros., Manchester, manufacture.

The motor is manufactured by the Lancashire Dynamo & Motor Co., Manchester, whose Canadian officers are at 152-4 Bay St., Toronto.

A large corporation finds it very much to its advantage to have constantly in its employ a lubricating engineer who has direct charge and supervision of the machinery oiling in the various plants. He selects the oils and directs the handling of all lubricants. He saves twice his salary each year. A small manager who can't afford a special man sends his oils and glue to a consulting man for analysis.

FOUNDRY PRACTICE AND EQUIPMENT

Practical Articles for Canadian Foundrymen and Pattern Makers, and
News of Foundrymen's and Allied Associations. Contributions Invited.

Convention of the Allied Foundry Associations

Programme for the Meeting in Detroit, June 6 to 10—Some Excellent
Papers Have Been Arranged for—Canadian Foundrymen Should Attend.

The Detroit local committee will tender a complimentary dinner to the officers of the allied associations and to the Technical Press, on Monday evening, June 6, at the Pontchartrain Hotel.

The Ladies' Committee will give a trip around the city, and a theatre party, on Tuesday, June 7.

A smoker will be given at the Light Guard Armory, on Tuesday evening, June 7. Chairman Woodison has some original features to "pull off," and those who recall his previous efforts along this line will realize that a treat is in store for them. The ladies will be over at their theatre party that night, and as the theatre is located near the hotels, no one need leave early to call for their wives.

Officers are Busy.

Arthur T. Waterfall, president of the American Foundrymen's Association, will make an extended trip through the east, the middle of March. During this trip, he will meet the Philadelphia, New York and Pittsburgh foundrymen, and will hold a conference with Dr. Richard Moldenke, secretary of the organization, and perfect the plans for making this the greatest convention of the organization.

W. M. Corse, secretary of the American Brass Founders' Association, was in Detroit on March 4 and 5. He reports that the membership of his organization has increased over 50 per cent. during the past year. Mr. Corse is now with the Lumen Bearing Co., of Buffalo, and the new address should be noted when writing him.

Richard Moldenke, secretary of the American Foundrymen's Association, returned from Europe on March 1, and from this time on his whole energies will be devoted to furthering the coming convention.

Joseph J. Wilson, has recently accepted the position of general superintendent of the foundry departments of the General Motors Co. Mr. Wilson is chairman of the Plant Visitation Committee of the convention, and is already planning to give the delegates every opportunity to visit the new and very up-to-date foundries, which have done so much to

make Detroit a centre of the foundry industry, especially relative to the automobile industry. He is conceded to be the greatest authority to-day on the production of auto engine cylinders in this country, and the work of his committee will doubtless prove to be one of the best educational features of the convention. It is not too early for those desiring to visit certain particular plants, to get into communication with Mr. Wilson, that he may make suitable preparations.

Boat Ride on Detroit River.

The boat ride on Detroit River and Lake St. Clair will surely be one of the most enjoyable features of the social part of the convention. The probability will be that we will use the Ste. Claire, the new steamer of the Detroit, Belle Isle & Windsor Ferry Co. This steamer will go into commission just before the convention opens, and she is the very latest word in pleasure steamer construction. She will handle fully 4,000 people, and no one will be crowded. The trip will last from late in the afternoon till midnight, and good music, and something good to eat will be provided by the committee. Ladies along, of course. Oliver Phelps, resident manager of the M. A. Hanna Co., has charge of this.

Incidentally, speaking of Detroit as a foundry centre, there are 10 foundries under construction here at the present time. Three of them will be the largest of their kind on the continent.

The local committee has already arranged for Postal and Western Union wires into the exhibit, and for telephones with a central switchboard and ample operators. The Detroit Police Dept. furnishes the needed uniformed men, and the Fire Dept. will station a company on the grounds to give the needed fire protection. Electric apparatus will be provided, to anticipate the needs of those who desire to illustrate technical papers in a proper manner.

The chairman of the convention sessions committee, W. P. Putnam, who is spending a few weeks in Arizona at this time, is perfecting the most perfect arrangements to assist those who desire special features in their papers. Write

him at 1111 Union Trust Building for anything wanted in this line.

James S. Keightley, supt. of the Great Lakes Engineering Works, is chairman of the reception committee. He is so well known for his genial smile and glad hand, that the right kind of welcome is assured for delegates.

Hotel Headquarters.

The local committee has established headquarters at the Pontchartrain Hotel. President Waterfall and Chairman Stephenson will be found at Parlor H, when they are not at the convention meetings.

The F. & M. S. Association will have its headquarters at the Cadillac Hotel. The American Foundrymen, the Brass Founders and the local committee will have headquarters at the Hotel Pontchartrain. The Foundry Foremen will use the Griswold House as headquarters. All these hotels are located near together, and ample room will thus be made for all. The Hotel Tuller, the Metropole, the Wayne, the Ste. Claire, and the Normandie all within a few blocks of each other, will doubtless receive their quota of visitors.

The date of the convention is purposely arranged with the Detroit Convention and Tourist Bureau so as to occur at the time when no other convention is in Detroit, thus offering the best possible accommodations to our delegates. Remembering the experiences of former conventions, it is well to reserve rooms at once, and be assured of a good place. The phenomenal growth in the associations reported by the secretaries, point to the largest convention in the history of the organization.

N. K. B. Patch, Toronto, is chairman of the committee on papers for the meeting of the American Brass Founders Association. He reports some very good ones are already promised.

On Thursday evening, February 17, at the association rooms in the Stevens Building, Henry M. Lane, editor of "Castings," Cleveland, O., presented to the Detroit Foundrymen's Association a splendid paper on "Modern Metallurgy and the Electric Furnace."

The development of the electric furnace in recent years has made possible the manufacture of an extensive line of ferro-alloys, refractory materials, abrasives, and other products which are used extensively in foundry practice. The

speaker traced the history and development of the electric furnace, noted the different types used, their relative advantages, the uses of the different products in the foundry, and the field the electric furnace is destined to occupy in modern metallurgy.

In this connection reference was made to a duplex process in which the electric furnace is used to finish or refine metal melted in some other furnace. The lec-

technical session of the convention also claims a large interest for those attending. The commercial consideration makes a very strong appeal, and it is true that any exhibit that can show the proprietor or superintendent how he can save money is a first-class attraction. The excellent work done by the American Foundrymen's Association with the accumulative influence it has exerted has been the exciting cause. The associa-

the cost per 100 lbs. for net, clean castings, without extra clerical force or cost, or causing undue work for foundry foreman, assistant, or cleaning-room foreman. This system is not perfect and could be improved. To do so in our case, would require more clerical force, which would increase the non-producer cost per 100 lbs. net, clean castings. For instance, in case of a pulley with a cracked arm that was to be remelted ;

DAILY FOUNDRY REPORT.

Goldens' Foundry and Machine Co., Columbus, Ga. Date _____

NAME	Hour or Piece Rate	Number of Molds	Number of Castings	Help	PATTERN DESCRIPTION	Pulleys	Shears	Hangers	Hanger Boxes	Pillow Blocks	Couplings	Cane Mills	Lumps	Factor	Agricultural	Miscellaneous	Number Pieces Lost	Weight	CAUSE	

Fig. 1. — Daily Foundry Report.

ture was illustrated with about fifty lantern slides, and the speaker, also, had on exhibition a large collection of electric furnace products, including ferro-alloys, abrasives, refractory material and pure metal, together with the materials from which these products are made.

.. The above talk was one of the series at the monthly meetings of the Detroit Foundrymen's Association in the interest of advancing the foundry's art. The meetings have been remarkably well attended both by the foundry executives of the many foundries in Detroit, but also the foundrymen within easy distance from Detroit. The enormous advance of the automobile industries here has led to an eager seeking after the very latest and up-to-date methods of production on the part of the foundrymen engaged in the manufacture of brass, aluminum, gray iron, malleable or steel castings. The increasingly high standard of excellence demanded by the purchasers of these products has greatly stimulated the industries to meet this demand, and Detroit is making castings of the various metals, now, that equal or surpass any made in the trade.

Every Foundryman Should Attend.

The week of June 6, Detroit will be honored by the meeting here in convention of the American Foundrymen's Association, American Brass Foundrymen's Association, Foundry & Manufacturers' Supply Association, and the Association of Foundry Foremen. The fact that something like five thousand foundry executives are coming from all sections of the United States and Canada to gather together at Detroit convention is significant enough in itself. Unquestionably the exhibit of mechanical equipment on which so large an outlay is made, accounts for the great outpouring, but the

tion has marked the lines of advance and mechanical invention has met the need.

Large Exhibits.

Canadian Machinery has a letter from C. E. Hoyt, Lewis Institute, Chicago, Ill., secretary of the Foundry & Manufacturers' Supply Association. Applications for space have been received for an amount in excess of that called for at any previous convention.

Dr. Frank T. F. Stephenson, Detroit Saw & Brazing Works, 12-14 West Atwater St., is the energetic chairman of the general convention committee. Information will be promptly supplied by application to this address.

SUCCESSFUL FOUNDRY COST SYSTEM.*

* Read before Cincinnati Convention A.F.A.

By J. P. Golden, Columbus, Ga.

A practical simple cost system, suitable for foundries doing a business of 125,000 to 150,000 lbs., net, clean, me-

without inquiry, I wished to know why it was to be made over, and by whom returned. The system referred to covers this case, also by whom the pulley was made, the time taken in making, weight of pulley, to whom sold, cause of crack, etc. These records are all accessible to both superintendent and foundry foreman under this system.

In the event of a molder asking for a raise, the system shows either the superintendent or foreman what class of work the man has been working upon, his record, his present pay, whether by hour or piece, and the number of pieces lost, as well as the weight molded, also the means of comparing the wages and output of one man with another.

I also wished to have a method whereby the foundry foreman could see exactly what each department was doing, to allow him to correct any bad practice that he might control, so far as rested with him.

I wished also to know at a glance

SAMPLE OF ENTRY.

Date Returned	By Whom Returned.	Description	Cause	Whose Fault	Weight.
Apr. 26, '09	Our Mch. Shop	1 S. B. Pulley 36 x 8—2 1/16 in. bore.	Bored too large	Mch. Shop	240 pounds
Apr. 29, '09	Our Mch. Shop	1 Split Pulley 24 x 6—2 1/16 in. bore.	Broke lug in splitting	Mch. Shop	120 pounds
May 3, '09	Customer	12 Gear Castings P. 2.	Cored too large	Foundry.	14 pounds
May 5, '09	Foundry	1 D. B. Pulley 36 x 8—2 1/16 in. bore.	Blow hole in face	Foundry.	260 pounds

Fig. 2.—Defective Castings Record.

dium, and light grey iron castings per week, with an approximate force of 75 to 100 men.

My object in devising the following system, was to enable me to have a ready means of reference and comparison in the several foundry departments at all times, and incidentally to lower

what the cost per hundred lbs. for clean castings was for last week, or last year, or the average for a year. How many pounds net clean castings were made in any week, or the average for a year, with the per cent. loss for bad castings. As to wage cost alone for 100 lbs. for any week, or yearly aver-

CANADIAN MACHINERY

age. What the cost per hundred lbs. was for either the non-producers, rumbling department, molding department, core shop, day or night cleaning gangs.

I also wished to separate the different kinds of castings into classes, with current prices for these castings, for both our shop and customer, so that having the approximate cash value of castings, and deducting therefrom the cost of pig, scrap and coke, wages, and fixed expense per 100 lbs. clean net castings, I would be able to find the approximate cash profit per week.

After a satisfactory trial of the following system for nearly two years, without extra clerical force or cost, (the weekly report being made up in the unoccupied time of a draftsman), it has occurred to me that there might be other members of the association to whom my system might be of interest; therefore, I have submitted this paper.

Daily Cupola Report.

The system consists of, first: a daily cupola report, Fig. 1, the printed form having column for charge, number pounds coke and brand, pounds pig iron and brand, and per cent. silicon and sulphur, scrap, foreign and returns, and total charge, also lines for weekly totals for use in weekly report. Ratio of coke to iron. Time started blast. Time dropped bottom. Average blast pressure. Per cent. sulphur in heat. Per

cent. silicon in heat. Remarks. With each sheet signed by foreman.

Daily Foundry Report.

Second: the Daily Foundry Report, which is made up by the rumbling room foreman. This report consists of a sheet, with columns for name of molder, hour or piece rate, number of molds, number castings, time of helper, pattern description, with columns for weights of the various classes of work, as pulleys, sheaves, hangers, hanger boxes, pillow blocks, couplings, cane mills, factories, miscellaneous, etc. Also column for number of pieces lost, total weight of each kind of piece lost, and a cause column for same, showing if it did not run, if was crushed, blowed, or whatever cause of defect. There is a line at bottom of sheet for weekly totals, to be used in weekly report. The daily foundry report furnishes a ready means of comparison of each molder's record, with his own, or with other molders, as to quantity of good castings, castings lost, weight and cost of same. This report also shows the amount of good and bad castings for each day, in each class, with the weekly total for each.

Defective Castings.

Third: there is a book for defective and other castings returned from shop and customers, Fig. 2, in which is the following rule:

"All castings returned by machine shop customers, before being made over, must be entered in this book, giving cause for making over. Castings returned to foundry from shop or customers, through no fault of foundry, must not be deducted from net foundry castings, and should be considered as foreign scrap. If fault of foundry, they are charged back to foundry and are considered as foundry return scrap."

This book has columns for showing date returned, by whom, description, cause and weight. Without this book, there could be returned defective castings, which was the foundry's fault and made over without the superintendent's knowledge. With the "to be made over" casting book, all castings returned are specified therein. If the fault of the machine shop, it is so stated. If returned from customers, this is noted, with date, description, cause and weight. No casting is made over without being recorded in this book. This book being always open to superintendent and foreman, saves inquiries and explanations. Possibly a few examples here will make the value of this book plainer. For example: the superintendent upon examination of this book, finds a record of a split pulley 36 inches x 12 inches—2 1/4 inch bore, lug broken off in machine shop in splitting, or a record of a pulley 24 inches x 8 inches

WEEKLY FOUNDRY REPORT.

**GOLDENS' FOUNDRY AND MACHINE CO.
COLUMBUS, GA.**

FOR WEEK ENDING FRIDAY.		19	Pulleys	Sheaves	Hangers	Hanger Boxes	Pillow Blocks	Couplings	Cane Mills	Laminus	Factory	Agricultural	Miscellaneous	Total Weight
Bad castings returned from foundry														
Total pounds good castings made														
Defective castings returned from shop and customers														
Net good castings for week	Total amount ()													
Average per cent. of castings lost.														
Total pounds pig and foreign scrap charged in cupola			CUPOLA CHARGE.											
Net good castings for week	Remains:		Pounds pig iron @	per hundred	\$	Cost per hundred								
			Pounds foreign scrap @	per hundred	\$	pounds net castings								
			Pounds coke @	per hundred	\$	including pig iron								
			Total Wages \$			scrap, coke, wages								
			Total			\$								
			Material cost per hundred pounds net castings made as per sheet			\$								
			Total cost per hundred pounds net castings made as per sheet			\$								
Per cent. lost in remelt, cupola droppings, gangways, etc.														
Total melt														
Net good castings														
Per cent. bad castings, gates, etc., of total melt														
Including foreign scrap, returns and pig														

PROPORTIONATE WAGE COST PER HUNDRED POUNDS IN DIFFERENT DEPARTMENTS

NON-PRODUCERS			MOLDING DEPARTMENT		
No.	WAGES		No.	WAGES	
Foundry Foreman	\$	} Wages cost per hundred pounds net castings	Molders (White)	\$	} Wages cost per hundred pounds net castings
Foundry Assistant			Helpers (White)		
Pulley man			Helpers (Black)		
Crane man			Total	\$	
			CORE SHOP		
		} Wages cost per hundred pounds net castings	Foreman	\$	} Wages cost per hundred pounds net castings
Clerk			Coremakers		
Cupola tender				Help	
Cupola helpers			Total	\$	
			NIGHT CLEANING GANG		
Carpenters		} Wages cost per hundred pounds net castings	Headman	\$	} Wages cost per hundred pounds net castings
Watchman			Men		
Total	\$		Total	\$	
RUMBLING DEPARTMENT			DAY CLEANING GANG		
No.	WAGES		No.	WAGES	
Foreman	\$	} Wages cost per hundred pounds net castings	Headman	\$	} Wages cost per hundred pounds net castings
Assistant			Men		
Men				Total	\$
Total	\$		Total	\$	

GRAND TOTAL WAGE COST PER HUNDRED POUNDS \$

Fig. 3.—Weekly Foundry Report.

INDUSTRIAL ^A_N^D CONSTRUCTION NEWS

Establishment or Enlargement of Factories, Mills, Power Plants, Etc.; Construction of Railways, Bridges, Etc.; Municipal Undertakings; Mining News.

Foundry and Machine Shop.

The G.T.R. will build new engine shops at Brockville.

The Montreal Steel Works will erect a foundry at Montreal.

The C.P.R. will erect a new machine shop at Calgary to cost \$20,000.

The Regina Machine and Iron Works Co. will erect a foundry to cost \$5,000.

The Don Iron Works, Toronto, including all machinery, has been completely destroyed by fire.

The Down Draft Furnace Co., Galt, is running on double shifts, owing to the large number of orders received.

The machine shop of the Schofield-Holden Machine Co., Toronto, was damaged by fire to the extent of \$7,000.

Work on the Port Arthur Steel & Wagon Works plant will soon be started. It will have a big foundry attached.

The Bergmann Electrical Works, of Berlin, Germany, are considering the location of a branch industry at Montreal.

The Parker Foundry Co., Montreal, have been authorized by the Dominion Government to increase their capital from \$25,000 to \$100,000.

Fire did about \$5,000 damage in the furnace room at the premises of William Coulter & Son's brass works, 155 George Street, Toronto, recently.

The annual meeting of the Montreal Steel Works was held at Montreal, about the middle of March. The net earnings for the year 1909 show that the company had a most successful year.

A disastrous fire broke out on March 18th in the premises of Valentine & Martin, Waterloo, shoe manufacturers. The interior was gutted. The loss will be about \$30,000, which is partially covered by insurance.

The St. Thomas city council has closed a deal to loan C. Norsworthy & Co., foundrymen, \$10,000 for fifteen years, without interest, to enable the company to take over the manufacture of the Howard furnaces, now made in Berlin. They agree to employ fifty hands at the outset.

The McBrien Mfg. Co.'s nail and tack factory at Toronto, was damaged by fire on March 7, to the extent of \$1,000, and the machinery, etc., to the extent of \$5,500. The loss is only partially covered by insurance. It will be some time before the plant can be operated again.

Shurly & Dietrich, Galt, the largest saw manufacturers in Canada, have dissolved partnership, G. J. Shurly retiring. The business will be carried on by J. C. Dietrich forming a joint stock company, with increased capital. Included in the transfer are the iron and brass bestead works and the R. H. Smith Saw Works, St. Catharines.

Brent, Noxon & Co., Toronto are placing the bonds of the Standard Drain Pipe Co., of St. John, P. Q., on the market. Among the lines manufactured are chimney tops, fire bricks, locomotive arch bricks, chimney fire proof linings, and all kinds of vitrified clay and fire clay products. The output of the two factories at St. John, P. Q., and New Glasgow, N.S., amounts to 2,000 carloads per annum.

Tenders addressed to the Commissioners of the Transcontinental Railway, Ottawa, will be re-

ceived until April 12 for the following: Machines and tools; leather belting; shafting, hangers, steel frame work, etc.; miscellaneous equipment, industrial track and lockers; motors; furnaces and forges; cranes; air compressors; grey iron foundry equipment and brass foundry equipment.

In a recent issue we referred to the Canadian Crocker Wheeler Co., Montreal, locating in St. Catharines. They have purchased a site of 8 acres, on which are practically new buildings having a floor space of about 30,000 sq. ft. The company is installing in these buildings tools and equipment for the manufacture of electrical apparatus. It is understood that all the necessary equipment has not yet been purchased.

A disastrous fire occurred near Campbellcroft, in Hope township, on March 16th, when a large frame barn, owned, it is said, by the Toronto Loan & Savings Co., was destroyed. Mr. Stewart Dean, who is going west, had just vacated the farm, and Mr. Thomas Worr was moving in and had placed a couple of loads of hay and other feed in the barn. He first noticed flames bursting from the upper part of the barn, and after considerable trouble managed to get his horses out.

At the annual meeting of the shareholders of T. McAvity & Sons, foundrymen, St. John, T. McAvity, president of the board of directors retired from that post and G. McAvity was elected in his stead. J. A. McAvity was made vice-president and J. W. McAvity succeeds his father, the late J. H. McAvity, as a member of the board. C. Caster was elected secretary. One of the matters discussed at the meeting was the future of the company's iron foundry, which it has been stated might be removed to the west. An offer from Port Arthur has been under consideration for some time, and another came more recently from Montreal, while Toronto has also been considered. No decision has yet been reached in the matter, and the directors will make a report at a later date.

Electrical Notes.

Summerside, P.E.I., will instal a new street lighting system.

The work of installing the new pump at Fenelon Falls has been completed.

The Sackville, N.B., Electric Light Company inaugurated its system of electric power early in March.

The Toronto Electric Light Co. has installed a large steam turbine as an addition to its present steam reserve.

The Canadian-British Insulated, of Montreal, have been awarded the contract for the cable for the electric power plant at Toronto.

The Railway Committee has passed the Montreal Central Terminal bill with the elimination of clauses authorizing the acquisition of lighting and power companies.

The necessity of enlarging the electrical plant at Victoria to permit of increased service in street lighting is being considered by the electric light committee of the council.

A year from now the Electrical Development Co., Toronto, will increase the capacity of their plant from 50,000 to 85,000 horse-power. Orders for three machines were given some time ago.

The Canadian Westinghouse company's tender for equipment for the power terminal station at Winnipeg, was recommended by the board of

control for acceptance. The price of the tender is \$116,500.

The following contracts for transformers were awarded by the Toronto city council: Canadian General Electric Co., \$8,800; Canadian Westinghouse Co., \$5,430; Allis-Chalmers-Bullock, \$12,670.

The Dufferin Light & Power Co. has purchased the Shelburne and Orangeville lighting plants and a water power at Horning's Mills capable of developing 1,000 h.p., which it intends developing the coming summer.

The following were the tenders received for the full equipment for the installation of Niagara power at St. Thomas: Canadian General Electric Co., \$19,050; Lancashire Dynamo & Motor Co., \$18,447, and the Canadian Westinghouse Co., \$18,170.

The Campbell Lumber Co., Weymouth Bridge, N.S., are contemplating the installation of an electric plant at the Upper Site, known as Sisiboo Falls, to generate electricity for their lower pulp mill, as well as lighting the neighboring towns.

The following are included in the supplementary estimates of the Ontario Provincial Treasurer: Electric plant, Hamilton Asylum, \$12,000; electric plant, London Asylum, \$25,000; electric plant, Ontario Agricultural College, Guelph, \$15,000.

The Erindale Power Co., Erindale, Ont., sustained a loss of \$1,200 by an unexpected flow of ice which rushed down upon their new dam on the Credit River at Erindale. The ice made a gap in the centre of the dam about 75 feet in length. The damage was repaired.

C. H. Mitchell, of Mitchell & Mitchell, consulting engineers, Toronto, has reported favorably on La Colle Falls, near Prince Albert, Sask., as a site for power development. The proposed plans call for a canal a mile long and a dam across the river 750 feet in length.

A. W. E. Fawkes is inspecting two power sites in the vicinity of Montreal, one where 40,000 horsepower can be developed at a cost of \$200,000 and another where from 10,000 to 12,000 horsepower can be developed at a probable cost of \$150,000, for additional sources of power for Montreal's lighting system.

The year 1910 promises to be one of rapid extensions for the Ontario Power Co., of Niagara Falls. General Greene, vice-president of the company, outlined the programme about the 1st of March, which includes the immediate installation of a second 18-foot conduit tube, and the excavation of rock for the third and final tube.

Some of the recent contracts closed by the Canadian General Electric Co., Toronto, are with the Electrical Development Co., of Ontario, who are duplicating their output at Niagara Falls, this order calling for three enormous generators of 15,000 horsepower each, which establishes a world's record for size of individual units. The Ontario Power Companies' order called for three generators of 12,500 horsepower each.

Municipal Enterprises.

Aldermere, B.C., will construct a waterworks plant.

The council of Medicine Hat, Alta., will spend over \$60,000 in extending the sewerage system.

F. W. Murdock, city engineer, of St. John, has been instructed to prepare plans and estim-

ates of cost for the renewal of pipes in the water distribution system. He will also prepare a report on the matter of additional hydrants.

Ladner, B.C., south of Vancouver, is securing plans for a new water system, to cost \$125,000. Winnipeg will call for tenders for 2,500 feet of water pipe, also for 150 valves and 50 hydrants.

City Engineer Childs, of Calgary, is preparing plans for a trunk sewer and septic tanks to cost \$800,000.

The New Glasgow, N.S., city council is again considering plans for increased water supply at an estimated cost of \$175,000.

The following by-laws will be voted on at Regina, Sask.; sewerage and waterworks extensions, \$10,000; exhibition buildings, \$25,000; market house, \$16,000.

The municipality of High River, Alta., will apply to the Provincial Government for power to borrow \$125,000, required for the construction of waterworks and sewerage systems.

Tenders addressed to the chairman of the Winnipeg-Board of Control will be received until April 4, for supply of cast iron water pipe, valves and hydrants for extension of the waterworks system.

City Engineer Ker, of Ottawa, has prepared the following estimates: sewer main, \$5,000; waterworks, old aqueduct, (renewing piers), \$4,000; renewing old services, etc., \$10,000; laying new services, \$15,000; renewing and repairs to hydrants, \$3,500.

Tenders were accepted by the Water Committee at Vancouver, for brass and water pipe fittings and upwards of 65,000 feet of galvanized water pipe. The successful bidder in the former was Crane & Co., at \$3,356.50, while A. J. Forsyth secured the latter at \$2,622.50.

The Toronto Board of Control awarded the contract for the construction of the outfall sewer, in connection with the sewage disposal works to F. H. Dickenson, Hamilton, for \$125,504. The Canada Foundry will supply the special castings needed in connection with the plant.

The contracts for the equipment of the pump-house at London were awarded to the following: turbine pumps, J. McDougall & Co., Montreal, \$5,640; motors, dynamos, etc., Lancashire Dynamo and Motor Co., Manchester, England, \$11,032; compressors and gas engines, G. H. & H. J. Daniels, Stroud, England.

Sealed tenders will be received until noon on Wednesday, April 6th, 1910, for the building of concrete abutments and floor for a steel bridge to be erected over the Sydenham River between the Townships of Moore and Sombra. Plans and specifications can be seen at the office of the undersigned, and also at the office of Bell & McCubbin, Civil Engineers, St. Thomas. T. H. Holmes, Colville, Ont., Neil McGugan, Wilkesport, Ont.

Sealed tenders will be received by the Weston Village clerk until 8 p.m. on Monday, April 18, 1910, for the following works:—Contract "B"—Pump house; contract "F"—Mechanical water filters; contract "G"—Electrically operated pumping machinery. Plans and specifications may be seen at the office of the Chief Engineer, Mail Building, Toronto, or at the town hall, Weston. J. H. Taylor, Esq., clerk, Weston, Ont. Willis Chipman, Chief Engineer, 204 Mail Building, Toronto, Ont.

Sealed tenders will be received by the Secretary-Treasurer of the town of North Battleford until 8 p.m. on Tuesday, April 19th, 1910, for the following works:—Contract "A"—Pipelaying, waterworks, and sewers; contract "D"—Cast iron water pipes; contract "E"—Fire hydrants, valves, etc.; contract "L"—Concrete reservoir; contract "X"—Sewage disposal works. Plans and specifications may be seen at the office of the Chief Engineer, Winnipeg and Toronto and at the town hall, North Battleford. S. Cook-

son, Secretary-Treasurer, North Battleford, Sask., Willis Chipman, C.E., Chief Engineer, Winnipeg and Toronto.

Sealed tenders will be received by the secretary-treasurer of the town of Weyburn, until 8 p.m. on Wednesday, April 27th, 1910, for the following works:—Contract "A"—Pipelaying on the sewerage system; contract "B"—Water works pump house; contract "B2"—Power house; contract "F"—Mechanical water filters; contract "G"—Water works pumping machinery; contract "S"—Sewer pipes; contract "W"—Furnishing wooden stove pipes; contract "X"—Sewage disposal works. Plans and specifications may be seen at the office of the Chief Engineer, Toronto and Winnipeg, and at the town hall, Weyburn. Geo. Ross, Esq., secretary-treasurer, Weyburn, Sask. Willis Chipman, C.E., Chief Engineer, Winnipeg and Toronto.

Sealed tenders will be received up to 12 o'clock noon, on Wednesday, April 6th, for the following:—(A) All works required in connection with construction of abutments to bridge at M. P. 48.91. Tenders to be marked on the envelope, "Tender for Abutments." (B) All the works required in connection with construction of substructure of steel trestle for Wabis River, M.P. 119.13. Tenders to be marked on envelope, "Tender for Substructure of Steel Trestle Spans." Plans and specifications may be seen, and forms of tender procured, at the office of the Secretary-Treasurer, 25 Toronto Street, Toronto, and at the office of the Chief Engineer, North Bay. A. J. McGeer, Secretary-Treasurer, of Temiskaming and Northern Ontario Ry., 25 Toronto Street, Toronto.

Structural Steel.

The Collingwood, Ont., council is considering a \$10,000 bridge by-law.

County Engineer Bell is preparing plans for the construction of a steel and concrete bridge at St. Thomas.

Work on the construction of the C.P.R. bridge at Fort William is to start as soon as the necessary order is secured from the Dominion Railway Board.

The contract for the construction of a steel viaduct over the North Wabie river has been awarded to the Hamilton Bridge Co. by the Commission of the T. & N. O. Railway.

The Bank of Montreal have awarded to the Dominion Bridge Co., Montreal and Winnipeg, the contract for steel and iron work on their new building at Winnipeg. Between 600 and 700 tons will be used.

The contracts for reinforcing steel and iron stairways, etc., for the transformer station for the Calgary Power & Transmission Co., at Exshaw, Alta., have been awarded to the Manitoba Bridge & Iron Works, Winnipeg.

The residents of Annacis Island, near New Westminster, are anxious to secure a \$40,000 bridge to connect their island with Lulu Island.

The contract for the new superstructure for Louise bridge, Winnipeg, has been awarded to the Algoma Steel Bridge Co., Winnipeg, at \$134,450.

The Canada Foundry Co., Toronto, is sending a large amount of steel to British Columbia for construction purposes. Eleven carloads are now on the way, considerable of this to go into the construction of the new eight-storey building to be erected by the Canada Life Assurance Co., at Vancouver. In addition, six carloads of steel are also to be sent here by the same company to be used in the new transmission towers to be erected by the B.C. Electric Railway Co., at New Westminster.

The Manitoba Bridge and Iron Works, Winnipeg, have erected fire escapes on the Royal Hotel, Fernie; Public School at Stony Mountain, Man., and the St. Boniface Convent, St. Boniface, Man. They also have contracts for the

structural steel for the new Bank of Montreal, Winnipeg; R. H. Williams' Departmental Store, Regina; Winnipeg Veterinary Hospital, and the new Union Station, Fort William, also for the iron and steel for four combination span bridges at Shellmouth and Russell, Man., and the new bridge over the railway tracks at Saskatoon.

Planing Mill News.

P. A. Paulson is erecting a \$100,000 sawmill at Kitchener, B.C.

Construction has begun on the Joyce sawmill, six miles from Quesnel, B.C.

McMaster Bros., of Kemptonville, Ont., are erecting a \$20,000 saw mill near Aymer, Que.

The sawmill of J. H. Gignac & Co., at Quebec, was damaged recently to the extent of about \$70,000.

The planing mill of Madden Bros. & Brown, at Toronto, was damaged by fire to the extent of \$8,000 on March 14.

The planing mill and residence of Trefle Bergeron, at Murray Bay, Que., were destroyed by fire recently. Total estimated loss, \$70,000. Mill and residence will be built at once.

The Guelph Patent Cask Co., Woking, England, bought out the timber limits and other property of the Great Northern Lumber Co., Scotstown, P. Q. The deal involves several thousand acres of lumber limits, besides several large mills. The company will start operations soon.

The new woodworking factory at St. John, which is to take the place of the one owned by A. E. Hamilton and destroyed by fire a few weeks ago is almost completed and Mr. Hamilton is again working on the contracts which were held up on account of the fire. The re-organized company has a capital of \$50,000.

General Manufacturing News.

The Oblate Fathers will build a printing office at Winnipeg.

A number of St. John men are seriously considering a project for establishing an automobile factory at that place. Geo. Fleming, one of the proprietors of the Phoenix Foundry, is said to be one of the most active promoters of the scheme.

The contract for the construction of the Western Dry-dock and Shipbuilding Co.'s plant, Port Arthur, Ont., has been awarded to the Canadian Stewart Co., of that city. The cost of the whole will be upwards of \$1,000,000. The company has the assurance of two big steel freighters to build when the plant is completed.

Building Operations.

A new high school will be erected at Victoria.

A general hospital will be erected at Princeton, B.C.

Methodists of Regina will establish a college to cost \$250,000.

A new general hospital will be erected at Smith's Falls.

The Winnipeg school board will erect a school to cost \$80,000.

The Holland Varnish Co. will erect a new factory at Montreal.

An isolation hospital will be erected near Grand Forks, B.C.

George Weston will erect a four-storey biscuit-bakery at Toronto.

The Dominion Government will erect a drill hall at Fernie, B.C.

J. H. Todd is to spend about \$40,000 on a building at Victoria.

The Great West Saddlery Co. will erect a factory at St. John, N.B.

The reconstruction of Manitoba's legislative buildings will cost \$400,000.

The Dowsley Spring & Axle Co., Chatham, will extend their plant this year.

Catholics of North Sydney, N.S., will erect a church to cost \$18,397.

A new and up-to-date opera house will be erected at Brockville, Ont.

The Presbyterians of Vancouver will erect a new church on Pender Avenue.

Walker, Parker Co. will erect four-storey brick addition to factory at Toronto.

An office building will be erected on the Baner block, Vancouver, to cost \$225,000.

The Ottawa Vacuum Cleaner Co., contem plate locating at Brockville, Ont.

The Urban Mutual Insurance Co. will erect an office building at Portage la Prairie.

A new armory and post office will be erected at Strathcona, Alta., to cost \$200,000.

Bonar Presbyterian congregation will erect a new church at Toronto to cost \$38,000.

An undenominational residential college will be erected at Moose Jaw, to cost \$300,000.

Toronto Showcase Co. will erect a two-storey brick factory at Toronto to cost \$32,000.

Lever Bros., Toronto, will build an addition to their factory at that place, to cost \$17,000.

The contract for a new school at Stratford has been awarded to Wilson & Wilson for \$68,000.

C. P. Walker, of Winnipeg, will erect modern theatres at Winnipeg, Fort William and Saskatoon.

A mammoth department store is to be erected by the Marshall Field Co., of Chicago, at Winnipeg.

D. R. Smith, of Boston, is considering the erection of a hotel at Kingston to cost not less than \$250,000.

The Parisian Laundry will build a three-storey brick addition to their laundry at Toronto, to cost \$11,000.

Wilson & Wilson, of Regina, were awarded the contract for the new public school at that place to cost \$68,750.

Tenders are being called for the new \$100,000 twelve-roomed school to be erected by the Edmonton Public School Board.

A. C. Hope has prepared plans for R. M. Edgar for a new six-storey apartment house at Vancouver. Estimated cost \$175,000.

The Victoria Department of Public Works has awarded the contract for an eight-room school house to A. J. Prudhomme at \$26,000.

The Dominion Office and Store Fitting Co. will erect an addition to its factory at the corner of Dundas and Patrick Streets, London.

G. H. Archibald & Co. have been awarded the contract for the construction of the plant of the Western Canada Flour Mills Co., at St. Boniface, Man.

The Geo. White & Son Co. will spend \$50,000 on their plant at London. Permits have been issued for two buildings to cost \$49,000 and \$10,000.

Mason & McLeod will erect an apartment house at Vancouver to cost \$80,000. Another apartment house will be erected by G. King at that place to cost \$25,000.

The City of Winnipeg is making an application to legislature for an amendment to the charter, so that \$500,000 may be raised for hospital and morgue purposes.

Among the recommendations made by the University Commission at Winnipeg is one for the establishment of an engineering college and a college of domestic science.

The ratenayers of Saskatoon will vote on the following by-laws: \$100,000, hospital; \$9,000, collegiate institute; \$21,000 for completing civic hospital and buildings for fair purposes.

Chatham is to have two automobile factories The Swift Motor Car Co. and the Aubert Co.,

both of Detroit, have concluded arrangements for the location of their factories at that place.

Work has commenced on what will be the largest building in Victoria. This is the eight-storey block to be erected by J. A. Sayward, on Douglas Street. The building will cost \$200,000.

The new naval college in connection with the Government's naval scheme will be built at Halifax, and will cost \$150,000. A barracks for the staff and possibly an admiralty dockyard may also be erected at that place.

The following building estimates have been prepared by the Toronto Board of Education: Technical School, \$100,000; Oakwood High School, \$90,000; Frankland School, \$60,000; additional to Humberline Avenue High School, \$40,000; additions to Public Schools, \$300,000; Manning Avenue School, \$90,000. Total, \$740,000.

Railway News.

The New Brunswick Legislature outlined a plan to run an electric line from St. John, N.B., to Quebec City across the State of Maine.

The Great Northern line from Orville, Wash., to Penticton, B.C., has been located. Forty miles of road may be built this year.

Early this summer the Grand Trunk Pacific Railway will take over the 1,200 miles of completed road between Winnipeg and Edmonton.

The contract for the construction of the G. T.P. wharf at Vancouver has been awarded to C. J. Johnson & Co., Vancouver and Seattle.

The Niagara Falls, Welland & Dunnville Electric Railway has been incorporated to build a railway from Niagara Falls to Welland and Dunnville.

A survey party of the C.P.R. has passed through Watrous on a newly-proposed road between Regina and Prince Albert. Watrous is named as a C.P.R. Divisional point.

J. N. Stewart & Son are reported to have secured contracts from the Vancouver, Victoria & Eastern Railway Co. for construction of two sections of its line aggregating 18 and 51 miles of track.

Application will be made to the New Brunswick Legislature for the incorporation of the Gibson & Minto Railway Co., with a capital of \$98,000 and authority to connect the New Brunswick railway with the I.C.R. near Gibson.

New freight car shops, six stall addition to Ignace engine house and several standard section houses and station buildings on the Central Division, C.P.R. will be erected this year. Frank Lee, Winnipeg, Divisional Engineer.

Bids are asked by J. S. Dennis, assistant to the second vice-president, C.P.R., Calgary, Alberta, until noon, May 1, for all excavation required to complete the canal system in the eastern section of the C.P.R. Co.'s irrigation block, Alberta, amounting to upward of 25,000,000 cu. yds. of material. Plans, specifications and all other information may be seen at the office of the assistant chief engineer, Calgary, Alberta.

Railway construction tenders will be received up to 12 o'clock noon, April 15, 1910, for the clearing, grading and bridge work on the 31-mile (more or less) section of the Algoma Central & Hudson Bay Railway, between Hawk Lake Junction, Algoma Central & Hudson Bay Railway, and Hobon, Canadian Pacific Railway. For plans, specifications and details apply to C. N. Coburn, Chief Engineer, Algoma Central & Hudson Bay Railway, Sault Ste. Marie, Ont., to whom all tenders should be addressed.

New Companies.

Toronto Structural Steel Co., Toronto; capital, \$250,000; to buy, sell and manufacture steel and iron. Incorporators, G. Grant, A. Dods and M. MacDonald, Toronto.

Bebmina Consolidated Asbestos Co., Montreal; capital, \$2,600,000; to mine, manufacture and deal in asbestos. Incorporators, W. L. Bond, J. J. Meagher, J. E. Coulin, Montreal.

B. J. Coghlin Co., Montreal; capital \$200,000; to manufacture and deal in iron, steel and railway supplies, etc. Incorporators, B. W. Coghlin, G. R. Coghlin and N. J. Dowes, Montreal.

The Glidden Varnish Co., Toronto; capital \$100,000; to manufacture and deal in varnishes, stains and paints, etc. Incorporators, W. S. Edwards, J. F. McCarthy and J. Parker, Toronto.

Dominion Explosives, Ltd., Ottawa; capital, \$99,000; to manufacture and deal in explosives, powder, and ammunition of all kinds. Incorporators, J. Tamsden, N. Ross, H. G. Nicoll, Ottawa.

Dominion Safe & Vault Co., Montreal; capital \$525,000; to manufacture and deal in safes, vaults and metallic furniture, etc. Incorporators H. J. Fuller, W. McMaster and A. W. Wheatley, all of Montreal.

The Goodyear Tire and Rubber Co., Toronto; capital, \$250,000; to manufacture and deal in all kinds of rubber goods, etc. Incorporators, D. B. Simpson, W. F. Stearns and N. Wilson, Bowmanville, Ont.

J. W. Kilgour & Bro., Beauharnois, Que.; capital, \$300,000; to manufacture and deal in furniture, housefurnishings, beds, carpets, glass, etc. Incorporators, J. W. Kilgour, J. Wilson, R. W. Kilgour, Beauharnois.

Eastern Canada Steel and Iron Works, Quebec; capital, \$200,000; to manufacture and deal in engines, machinery, implements and boilers. Incorporators, C. Donohue, E. Duverger, both of Montreal, L. H. Gaudry, Quebec.

A. A. Fournier, Ottawa; capital, \$100,000; to manufacture, buy, sell and deal in stoves, grates, gas ranges, brass, copper, tin and galvanized iron. Incorporators A. A. Fournier, W. L. Jayner, F. D. Crowe, Ottawa.

H. A. Drury Co., Montreal; capital, \$200,000; to manufacture and deal in steel, iron, metals, machinery and contractors' supplies. Incorporators, H. A. Drury, Westmount, Que., C. L. Drury, Toronto, F. A. McDonald, Montreal.

Victor Steel and Wood Products Co., Walkerville, Ont.; capital, \$40,000; to manufacture and deal in show-cases, gasoline engines, trucks, cars, and automobiles, etc. Incorporators, J. H. Flinn, N. G. Begle and F. T. Chapman, Detroit.

A company with twenty million dollars capital has been organized at Montreal, under the name of the Montreal Elevated and Underground Railway Co., to build elevated and underground railways in the city and Island of Montreal.

The Wabi Iron Works Co., New Liskeard, Ont.; capital, \$40,000; to carry on a general foundry and machine shop business and to manufacture and deal in iron, steel and metal, etc. Incorporators, F. L. Hutchinson, A. W. Summers, S. Greenwood, New Liskeard.

National Glass, Ltd., Montreal; capital, \$45,000; to manufacture, buy and sell all kinds of glass, paints, varnishes, dyes and other similar articles. Incorporators, J. A. Dubois, W. LeFebvre, both of St. Chrysostome, and E. C. Frappier, Montreal.

Dominion Cement Co., Montreal; capital, \$5,000,000; to mine, manufacture and deal in cement, stone, sand, plaster and all minerals, metals, earths, etc. Incorporators, E. C. Eckel, Washington, U.S.A., G. W. MacDougall, F. Macfarlane, C. A. Page, Montreal.

F. Pierpon Shaw, St. John; Truman Beckwith, of Providence, R. I.; Charles Rosenthal, of Boston; Wm. G. Latz, of New Haven, and Theodore T. Hazlewood, New York, have applied to the Provincial Government for incorporation as the Big Six Coal Co., with a capitalization of \$2,000,000. The company propose to develop the soft coal areas near Chipman, N.B.

The Modern Railway Device Mfg. Co., Montreal; capital, \$1,500,000; to manufacture and deal in machinery or mechanical devices constructed under such patents, railway track material, steam or electric railway cars, metal goods of all kinds, tools, implements, engines and boilers. Incorporators, E. A. Bleakney, Ottawa, W. E. Hamilton, H. R. Emmerson, both of Montreal.

The Crossen Car Co., Cobourg, Ont., capital \$1,000,000; to manufacture and deal in locomotives, motor trucks, traction engines, motor cars, and to carry on the business of iron founders, mechanical engineers and manufacturers of all kinds of machinery, brass founders, metal workers, boiler-makers, and machinists. Incorporators, A. Falconer, Westmount, Que., M. A. Phelan and H. Stevens, Montreal.

Trade Notes.

Ekins & Norris, of Richford, Vt., were awarded the contract for the Catholic Church to be built at Bedford, Que.

The Prentiss Vise Co., vise manufacturers, who have been at 44 Barclay St., New York, for the past twenty years, have moved into large and commodious offices in the Hardware Bldg., 106-110 Lafayette St., New York.

Percy Woodward, of London, formerly employed at McClary's, the London Foundry Co., and Wortman & Ward's, has obtained a patent at Washington on a rotary engine which he has been working at for five years.

Northern Engineering Works, Crane Builders, Detroit, have been placing orders for new tools and machinery consisting largely of lathes, gear cutters and milling machines, etc., for several months past and the machinery is now being installed.

The Wm. Hamilton Co., Peterboro, have been awarded a large contract by the Simcoe Railway and Power Co., which includes the supplying of penstocks, standpipes and the installing of waterwheels and other portions of the plants, that the company is constructing on the Severn river.

On April 1st, the Tallman Brass & Metal Co., Hamilton, will start to manufacture brass finished goods. They are installing the latest machinery for this line. Since moving to their new plant last November they have doubled their output in brass castings, arctic metal and solder.

James L. McAvity, proprietor of McLean, Holt & Co., St. John, manufacturers of stoves and castings and retail stove merchants, has been gazetted colonel of the 62nd Regiment, succeeding Col. M. B. Edwards, who has been retired to the reserve staff. Col. McAvity plans to put the regiment on a voluntary basis and make it one of the crack militia forces of the Dominion.

Smart-Turner Machine Co., 191 Barton St., Hamilton, have recently supplied pumps of various designs to the following: David Morton & Sons, Hamilton; Lopp Bros., Locust Hill; Port Colborne, for waterworks pumping station; Hudson Bay Co., Edmonton; Normal School, Toronto; W. J. Finlay & Co., Stratheona; Petrolia Wagon Co., Petrolia; Canadian Hart Wheel, Ltd., Hamilton; Sam. Lacaille, Nominique, P. O.; Midland Navigation Co., Midland; Slingsby Co., Brantford; Thompson & Norris, Niagara Falls; Keenan Woodenware Mfg. Co., Owen Sound; Fowler's Canadian Co., Hamilton, and Miller Bros. Co., Glen Miller. They have supplied tumbling barrels to Laidlaw Bale Tie Co., Hamilton, and to Canada Screw Co., Hamilton. They have also supplied the Kingston Shipbuilding Co., with an independent jet condenser.

Lethbridge, Alberta.

The twentieth annual report of the Lethbridge, Alberta, Board of Trade has been issued in which the many improvements made in the city in 1909 are pointed out. C. G. K. Nourse is president.

London Machine Tool Co.'s Calendar.

The London Machine Tool Co., Hamilton, are mailing a calendar for 1910. Each page contains an illustration of one of their machine tools, the calendar forming a useful reference catalogue as well.

Coal in North Ontario.

Twenty miles of coal territory has been located along the Metagama River in Northern Ontario. The fields are 60 miles north of the G.T.P. and west of Cochrane. The T.N. & O. Ry. will probably be continued to them from Cochrane.

'First Engineers' Calendar.

Allis-Chalmers-Bullock, Montreal, manufacturers of hydro-electric plants, etc., have issued a 1910 edition of their 'First Engineers' calendar which received so much favorable comment a year ago. This calendar shows two beavers at work, the picture being appropriately named 'The First Engineers.'

Sumner Iron Works.

Work is to be started on the immense plant of the Sumner Iron Works in Burnaby municipality, about ten miles southeast of Vancouver, where a site comprising twenty acres has been secured. The present name of the station on the company's property is Ardley, but it is the intention of the company to rename it Sumnerton, in honor of the founder of the Sumner Iron Works, at Everett, Wash.

Tenders for Electric Light Plant.

Sealed tenders in duplicate, for boilers, engines, condensers, pumps and piping, together with electrical apparatus, for Prince Rupert, B.C., will be received by Thos. Dunn, chairman of electric light committee, Prince Rupert, B.C., up to the noon of the 3rd of May, 1910.

Plans and specifications and full particulars of delivery, etc., can be obtained from the chairman of the electric light committee at Prince Rupert, or from James Milne, consulting engineer, Loo Building, Vancouver, B.C.

Ship Building Plant for Winnipeg.

The Doty Engine Works Co., of Goderich, Ont., has organized a branch at Winnipeg and has applied for a Manitoba charter. The site for a shipbuilding yard has been obtained at the foot of Water Street, and offices have been established in the Bank of Hamilton building. In connection with the shipyard, the company will operate a machine shop and boiler shop for the construction of the machinery required for building the steam craft. Several contracts have been received for building steel steamers of the twin-screw type. It is expected that the plant will be operating before next fall.

Nova Scotia Steel & Coal Co.

The 9th annual statement of the Nova Scotia Steel & Coal Co., has been issued by Robert E. Harris, President. The profits for 1909 amounted to \$97,949, as compared with \$734,701.53 in 1908. The volume of business transacted by the company during the year shows a substantial increase being in excess of any previous year. During 1909 extensions were made to the mills at New Glasgow and further additions improvements and additions will be made during 1910 to increase the output of finished steel.

MACHINISTS, ATTENTION!

MACHINIST'S TOOL-CASE FREE to one man in every shop. Address, with stamp, O. BURCH, Grand Rapids, Mich. (3)

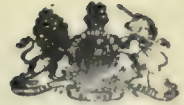

Notice to Contractors

Tenders for Machinery, Belting, Shafting, Cranes, Air Compressors, etc.

SEALED TENDERS, addressed to the undersigned, and marked on the envelope 'Tender for Machines and Tools,' 'Tender for Leather Belting,' etc., etc., as the case may be, will be received at the office of the Commissioners of the Transcontinental Railway, at Ottawa, Ontario, until 12 o'clock noon of the 12th day of April, 1910, for:

- (1) Machines and tools;
- (2) Leather belting;
- (3) Shafting, hangers, steel frame work, etc.
- (4) Miscellaneous equipment, industrial track and lockers;
- (5) Motors;
- (6) Furnaces and forges;
- (7) Cranes;
- (8) Air compressors;
- (9) Grey iron foundry equipment and brass foundry equipment;

required for the equipment of the locomotive and other shops of the Commissioners of the Transcontinental Railway at Springfield, east of Winnipeg, Manitoba.

Tenders will be received and considered for any or all of the items indicated above and numbered from 1 to 9, both inclusive.

Plans and specifications may be seen in the office of the Chief Engineer of the Commissioners at Ottawa, Mr. Gordon Grant, and in the office of the District Engineer of the Commissioners at St. Boniface, Man., Mr. S. R. Poulin.

Persons tendering are notified that tenders will not be considered unless made on the printed forms supplied by the Commissioners, which may be had on application to the Chief Engineer at Ottawa, or to the District Engineer at St. Boniface, Man.

Each tender must be signed and sealed by all the parties to the tender, and witnessed and be accompanied by an accepted cheque on a chartered bank of the Dominion of Canada, payable to the order of the Commissioners of the Transcontinental Railway for a sum equal to ten per cent. (10 per cent.) of the amount of the tender.

Any person whose tender is accepted shall within ten days after the acceptance thereof sign the contract, specifications and other documents required to be signed, and in any case of refusal or failure on the part of the party whose tender is accepted to complete and execute the contract with the Commissioners, the said cheque shall be forfeited to the Commissioners as liquidated damages for such refusal or failure, and all contract rights acquired by the acceptance of the tender shall be forfeited.

The cheques deposited by parties whose tenders are accepted will be deposited to the credit of the Receiver General of Canada as security for the due and faithful performance of the contract according to its terms.

The cheques deposited by parties whose tenders are rejected will be returned within ten days after the signing of the contract.

The right is reserved to reject any or all tenders.

By order,

P. E. RYAN,

Secretary, The Commissioners of the Transcontinental Railway.

Ottawa, 2nd March, 1910.

Newspapers inserting this advertisement without authority from the Commissioners will not be paid for it.

BUSINESS OPPORTUNITY.

A PARTY holding a large interest in a well-established prosperous machinery manufacturing company on the Pacific coast, wishes to dispose of part of his holdings to meet personal obligations. Can arrange if necessary for purchaser with proper qualifications to take an active part in the management. This is a splendid opportunity and investment for anyone wishing to get a start in a good, steady, legitimate, profitable business, in a young, growing country. Applicants who mean business, must have at least \$20,000, are invited to investigate. Write Box 102, CANADIAN MACHINERY, Toronto. (4)

INFORMATION

about every conceivable subject finds its way into the newspapers. The function of THE CANADIAN PRESS CLIPPING BUREAU is to collect ALL the items of information appearing in Canadian newspapers about any subject YOU are interested in. Our service is thorough. We don't miss an item. If you want ALL THE CURRENT INFORMATION about a pet subject, we can supply it at the lowest cost. By using our service you can KEEP POSTED on any subject.

WRITE FOR OUR FREE BOOKLET

THE CANADIAN PRESS CLIPPING BUREAU

232 McGill Street, Montreal

10 Front Street E., Toronto

ALUMINIUM

You can now get your Aluminium requirements promptly attended to by our clients, The British Aluminium Co., Limited, of

"The 20th Century Metal"

Lightest and most adaptable of the industrial metals. Fills a hundred purposes where the ordinary metals fail. Saves its cost over and over again by its lightness and easy working qualities.

London, the largest producers in the United Kingdom.

Sole Agents for Canada: Parke & Leith, 205 Yonge Street (Bank of Toronto Building) - - - Toronto.

INGOTS, BARS, SHEETS, RODS, ANGLES, ALLOYS, NOTCHED BARS, CORNICES, WIRE, CHANNELS, ETC.

To-day get Bulletin "D" on the varied uses of ALUMINIUM (Parke & Leith)

JESSOP'S BEST TOOL STEEL "ARK" High-Speed Steel

THE FAVORITE BRANDS WITH USERS OF GOOD STEEL.
A LARGE ASSORTMENT OF SIZES IN STOCK.
JESSOP'S HIGH-GRADE FILES AND RASPS.

80 Bay, St., Toronto, Ontario
Chas. L. Bailey, Agent.

Reid-Newfoundland Company
St. John's, Newfoundland.

Jas. Robertson Co., Ltd.
Montreal, Quebec

Jas. Robertson Co., Ltd.,
St. John, New Brunswick

WM. JESSOP & SONS, Limited, Manufactory, SHEFFIELD, ENGLAND.

We want your orders for

SPECIAL TAPS

Price, delivery, and quality will please you.

A. B. Jardine & Co., Hespeler, Ont

B. C. Steel Plant.

It is reported that a great steel plant, to cost between half a million and a million dollars, is to be established in the near future at a point on the Coast—probably on Vancouver Island—by James A. Moore, president of the Irondale Smelting Co., Washington, in conjunction with other prominent capitalists. Extensive coal deposits have been acquired on Graham Island, one of the Queen Charlotte group, in addition to enormous ore bodies on Quatsino Sound and Atlin, in the interior, where a rich magnesite mine was lately discovered. The steel plant, which is expected to employ about 2,000 men, forms only part of Mr. Moore's extensive scheme.

Galt Saw Works.

Shurly & Dietrich, proprietors of the Maple Leaf Saw Works, have dissolved, J. C. Dietrich purchasing the interest of C. J. Shurly. The intention of Mr. Dietrich is to form a joint stock company with largely increased capital, to go aggressively into foreign trade, and to take care of the ever-widening field in Canada. Included in the transfer is the Iron and Brass Bedstead Works, having been managed by his son, Percy G., for ten years. The R. H. Smith Saw Works at St. Catharines forms another link in the chain. The Maple Leaf Harvest Tool Works is another, this factory having been sold to the American Fork Trust in May, 1909.

Iron Works for B. C.

It is announced from Victoria, B.C., that Mackenzie & Mann, Vancouver and Victoria, backed by J. P. Morgan & Co., have purchased the Vancouver island coal mines owned by the Dunsmuir interests and known by the general name of the Wellington collieries, for the sum of \$11,000,000 cash. The mines included in the deal produce some of the best coal mined on the Pacific coast, including high grade bituminous steam, domestic and coking coals. It is announced that Mackenzie & Mann will spend \$5,000,000 on improvements to the property, including the erection of iron works, although no details are yet available.

May Establish Canadian Plant.

During the past year many United States concerns have established factories in Canada to take care of their business in the Canadian territory, and to have a share in the growth of trade on this side of the line. In this connection, Mr. S. H. Reek, Secretary of the Rockford Drilling Machine Co., of Rockford, Ill., was a recent caller at the Toronto office of "Canadian Machinery." He has been visiting Toronto, Hamilton and other points in Western Ontario, with a view to establishing a plant in Canada for the manufacture of drill presses and small lathes.

The "Soo" Industries.

Plans for extensions and enlargements involving an expenditure of over ten millions of dollars are being worked out by those in control of the Lake Superior Steel Corporation. The enlargement of the works already partly under way will call for an expenditure of approximately \$6,000,000, while extensions of the Algoma Central Railway, which is owned by the corporation, are being planned, to cost nearly \$5,000,000. Two large industries, representing an investment of over a million dollars, have recently located in the Soo. A company for the manufacture of chemicals from the by-products of the mills and representing \$1,000,000 capital has purchased the charcoal plant from the Steel Corporation. The Dominion Tar Co., capitalized at \$100,000, has purchased seven acres of land from the Lake Superior Power Co., and will erect a plant for the manufacture of coal tar from the by-products of the coke ovens.

SPECIAL MACHINERY, Etc.

ARMSTRONG BROS.

16 Sheppard St., Toronto
Mfrs. of **SPECIAL MACHINERY**
Patents Perfected
GEAR CUTTING, TOOLS, DIES, ETC.
Ruching and Pleating Machinery.

ERNEST SCOTT

91 BLEURY ST., - MONTREAL
Machinist and Tool-maker

Dies for sheet metal work. Stampings and light manufacturing. Special machinery designed and made to order.

The PARMENTER BULLOCH CO., Ltd.
GANANOQUE, ONT.

Iron and Copper Rivets, Iron and Copper Burrs, Bifurcated and Tubular Rivets, Wire Nails, Copper and Steel Boat and Canoe Nails, Escutcheon Pins, Leather Shoe and Overshoe Buckles, Felloe Plates.

OWEN SOUND IRON WORKS, LIMITED
OWEN SOUND, ONT.

Cement Mill Machinery, Boiler and Steel Tank Work of all kinds, Grey Iron and Brass Castings

PATTERNS AND MODELS

PATTERNS IN WOOD

~ ALL KINDS ~

Difficult Core Work a Specially High Grade - Right Prices - Prompt Delivery

SATISFACTORY WORK GUARANTEED

THE HAMILTON PATTERN WORKS
258 CATHERINE STREET NORTH
HAMILTON, ONT.

MAPLE LEAF
STITCHED COTTON DUCK
BELTING
DOMINION BELTING CO. LTD.
HAMILTON CANADA

Annual Meeting Canadian Westinghouse.

The annual meeting of the Canadian Westinghouse Co., Hamilton, was held recently. The annual report shows the following assets:—Cash, \$608,402.52; accounts and bills receivable, \$853,233.51; property and plant, \$2,766,488.97; materials and products on hand, \$1,269,728.44. Liabilities—Accounts payable, \$275,515.14; reserves for depreciation and inventory adjustment, \$320,000; undistributed profits, \$536,103.87. The profits for the year ended December 31, 1909, were, \$498,379.94. Dividends paid for 1909 at six per cent., \$261,540.33. The sales for the year were the largest in the history of the company, and were about double those for the year 1908.

Detroit Industrial Exposition.

Detroit is to hold an industrial exhibition under the auspices of the Board of Commerce, June 20 to July 6. The exposition grounds will on the Detroit River, where a huge exposition building will be erected and used in conjunction with the large Wayne Pavilion. Plans have been made to accommodate between 250 and 300 exhibits. Not only the products of Detroit's factories will be shown, but also the processes. Running machinery will demonstrate the most modern methods of transforming raw materials into highly finished articles. In one building the general departments will be machinery, metal products, paints, electricity, building supplies, rubber, leather and paper products, drugs and chemicals, tobacco, food products, novelties and specialties, while in the other building will be automobiles and accessories, wagons and carriages, furniture, textiles, boots and shoes, house furnishings, jewelry and scientific instruments.

The World's Greatest Steel Plant.

"The Greatest Steel Plant in the World" is the subject of a recent book issued by the Iron Age, 14 Park Place, New York. It is a description of the Gary works of the Indiana Steel Co., subsidiary to the United States Steel Corporation. The book is a reprint of a series of articles which appeared recently in Iron Age.

The plant is of unprecedented size and has commanded the interest and attention of the entire industrial world. The plant was projected under conditions unhampered by limitations of capital or site and the completed plant represents the acme of achievement in this branch of the world's achievements.

Every particular was considered before decisions were arrived at, so that the whole plant is a model of economy. A tract of 9,000 acres is utilized by the company. All the features are fully described in the book mentioned. Profuse illustrations serve to impress the reader with the greatness of the plant, the various units constituting the great steel plant being fully dealt with.

Becker Steel Agency.

William Abbott, St. James St., Montreal, has been appointed sole Canadian agent for the Becker Steel Works, Krefeld, Germany, maker of high grade tool steels, high speed chrome nickel, nickel and tungsten alloy steels, and high carbon steel tubing. The special features of this company's products are the employment of the Girod electric melting process which practically eliminates the phosphorus and sulphur in the steel and of strong hydraulic pressure on the liquid steel in the molds, producing a uniform product that does not vary materially either in analysis, tensile strength or elasticity.

Lack of uniformity in all classes of high carbon tool steel results in difficulty in tempering and hardening which is entirely eliminated by the process used in making the Becker steel.

An artistically colored catalogue is being issued by Mr. Abbott, containing particulars as

OPAL GLASS TILING
FOR WALLS OF
MACHINERY AND POWER HOUSES
Most approved material.
TORONTO PLATE GLASS IMPORTING CO'Y
PLATE AND WINDOW GLASS
135 to 143 Victoria St., - Toronto

Chief Draftsman AND ENGINEER

will personally—practically instruct a few ambitious, deserving, bright men on practical, actual, up-to-date **Drafting Room Work** at home, prepare and qualify them as first-class experienced Draftsmen and Designers for a salary paying **\$100 to \$180 per month.** Instructions until competent, and placed in position free. Also complete high grade drawing outfit, with German Silver set of instruments worth **\$13.85 free this month.** Don't answer this unless you are ambitiously seeking success and willing to work for results. Address **CHIEF DRAFTSMAN, Div. 23 ENGINEERS EQUIPMENT CO. (INC.) CHICAGO, ILL.**

YOUNG machinist or technical graduate wanted to travel. Must be good talker and resourceful. No previous traveling experience necessary. Splendid opportunity for ambitious man to work into a good position. Apply

BOX 101
Canadian Machinery
Toronto

A Unique Offer!

We have not the slightest doubt in our own minds as to the superiority of the

IMPERIAL CHUCK

and to introduce it to your shop we are prepared to send one—all charges paid—which you can use for 30 days. If it does not do all we claim for it, send it back at our expense. But we know no test is too severe for the **IMPERIAL CHUCK.**

Made in Canada.
Send for Catalogue.

KER & GOODWIN
BRANTFORD, - - CANADA



THE BEYER WATCHMAN'S PORTABLE CLOCK



IS TAMPER PROOF
and thoroughly reliable

Shall we send
Particulars?

G. C. BREDIN, Sales Agent

252 Dundas St. London, Canada

Record Dials furnished for all machines.

to the products of the Becker Steel Works, and tables of weights, rules for forging, hardening and grinding, annealing, etc., and prices f.c.b. Montreal. This catalogue is of interest to all merchants handling high grade steel, and to all users of it.

* * *

New Pipe Mill.

The Page-Hersey Iron, Tube & Lead Co., Toronto, manufacturers of steel and galvanized wrought merchant pipe, has completed and placed in operation a new tube mill at Welland, Ont., its product being 2½-inch to 8-inch lap weld pipe, as well as boiler tubes and well casing. The various buildings are all of treproof construction. The main or mill building consists of steel underframe with corrugated iron sides and roof, the finishing buildings being constructed of solid brick with cement floors, the reinforced concrete roof being supported by steel trusses. The dimensions of the various buildings are as follows: Main building, 80 x 200 feet; finishing department, 60 x 140 feet; socket department, 35 x 120 feet; storage department, 50 x 140 feet; machine shop, 35 x 120 feet; gas house, 30 x 66 feet; stock crane runway, 50 x 380 feet; coal trestle, 300 feet long.

The tube mill machinery was built by the United Engineering & Foundry Co., Pittsburgh; the furnaces by the American Furnace & Machine Co., Pittsburg. The mills are electrically driven by individual alternating current motors of General Electric construction, the power to drive the works being furnished by the Ontario Power Co., of Niagara Falls. The present output of the plant is 75 tons of finished pipe per turn.

* * *

W. D. Beath & Son to Enlarge.

W. D. Beath & Son, Toronto, were incorporated in Sept. 1909 with an authorized capital of \$100,000. This company proposes to purchase a property on a railway siding and build suitable buildings for their products, the present premises being too small to accommodate the workmen and machinery necessary for the needs of their business. The estimated cost of the new plant is about \$10,000.

The products to be manufactured include Beath's overhead tracks, carriers and hoists, steel kegs, shipping packages, hardware specialties, sheet metal of all kinds. They will also carry on a general business of iron and steel masters and iron founders' supplies, etc.

The officers and directors are:

W. D. Beath, President; L. B. Beath, vice-president; M. E. Gibson, accountant, secretary-treasurer; T. H. Mace, C.E., M.E., engineer; J. H. Milnes, president the Milnes Coal Co., Toronto.

Beath's overhead tracks is a carrying system run on overhead tracks, and is used for the economical handling of the products of manufacturing concerns in their factories and warehouses, in the various stages of manufacture. A number of the Canadian manufacturing plants successfully using the system are: The American Chicle Co., F. H. Fler & Co., Cosgrave Brewery, all of Toronto; J. Fleury's Sons, Aurora; The Metal Shingle & Siding Co., Montreal; The Toronto and Belleville Rolling Mill, Belleville, and The Empress Manufacturing Co., Vancouver, B. C.

* * *

C.G.E. Annual Meeting.

At the annual meeting held in Toronto recently, W. R. Brook, president, pointed out that since the close of the year the marked improvement in volume of orders received has been maintained, and present trade conditions warrant the belief that this improvement will continue.

The company within the last two or three months has secured some of the most important contracts for electrical apparatus ever awarded in any country, totalling nearly two hundred thousand horse-power. These include three generators of 15,000 horse-power each, three generators of 12,500 horse-power each, and two of 11,000 horse-power each, and for size and importance have no counterpart in the world today, and it should be gratifying to the shareholders that this company is in the foremost rank as manufacturers of high-class machinery of such magnitude.

The Canada Foundry Co. has just satisfactorily completed for the Canadian Government, at St. Andrew's Rapids, near Winnipeg, a movable dam of steel construction that is one of the most important engineering propositions yet undertaken in Canada, and have recently entered into a contract with the Dominion Iron and Steel Co. for the construction of their new blast furnace plant.

All departments of the Canada Foundry Co. are now back to normal production, the structural steel department being overtaxed. As they have had to forego much business for this department, because of insufficient capacity, the directors decided to provide for a largely increased output and negotiations are now pending for the acquirement of a suitable location for the extension of this department.

During the year the bank account was reduced below \$300,000, at which time our accounts receivable amounted to nearly \$2,000,000, but the rapid influx of orders necessitated the purchase of large quantities of raw materials, no less than \$400,000 of such materials, principally iron, steel and copper, having been received during the month of December, with the result of increased borrowing to a moderate amount.

The great development of the Canadian Northwest made it increasingly difficult to handle the business of that district from either the Vancouver or Winnipeg branches, and the directors arranged to open a new branch office in Calgary, Alberta, which is now in operation.

* * *

C.P.R. Work in the West.

Three new buildings will be erected by the C.P.R. in Calgary this year and large additions will be made to two others. The passenger station will be increased by the erection of a new wing, which will be almost 200 feet long and 35 feet wide. An addition to the freight car shop will be built 100 feet long. This is a brick building and the addition will also be of brick. A stores building of standard design will be built, 70 by 30 in size, and there will be a new engine house of 18 stalls and a new machine shop.

In Regina there will be built a large brick freight shed, 450 feet long. In Moose Jaw there will be built an addition to the present frame freight shed, 200 feet long. Weyburn will have a new freight building 100 feet long, and similar buildings will be erected at Granum and High River.

Large new stations of special design will be erected at Red Deer, and at two of the resorts in the mountains, namely Banff and Laggan. At Lethbridge, the present station building will be greatly enlarged, the addition proposed being 80 by 30 feet in size. At Coleridge and McLeod there will be six stall additions to the engine houses, and at Medicine Hat there will be new brick machine shops, 72 by 82 in size. In addition to these buildings, for which special plans are prepared, the C.P.R. will erect in the western division, new stations of standard design at Morse, Rush Lake, Marquis, Keeler, Loreburn, Strongfield, Glenside, St. Aldwyns, Tyvan, Erskine, Strome, Brocket, Cowley, Lundbrek, Welsh, Shepard, Hilerest, Blairmore, McGillivray, Natal. Between thirty and forty new section houses will also be erected during the summer, by the company in the division. Tenders for

STAMPINGS

Special Manufacturing to Order

No matter how hard a stamping problem you put up to us, the chances are we can satisfy you. Many people use stampings in place of castings and find them more satisfactory and often cheaper. Send blue prints and samples and let us quote you.

The Silent Partner is an interesting little magazine. We send it free—when there's a reason

THE GLOBE MACHINE & STAMPING CO.
399 Hamilton Street, Cleveland, O.

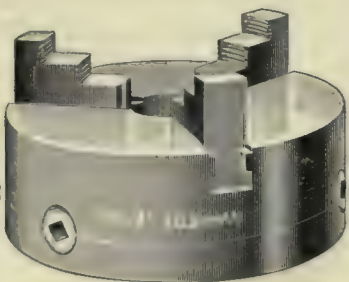

"CUSHMAN" CHUCKS

For general machinists' use.
Strong and durable and
designed for hard service.

Our catalogue shows many
styles and sizes and is sent
free. : : : : :

The Cushman Chuck Co.

Hartford, Conn., U.S.A.

Established 1862

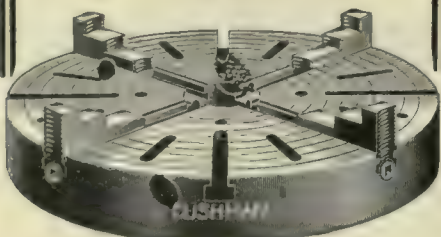

these various buildings are now being called for, and the contracts will be awarded in April.

On the central division there is less work of this class to be done, the only structure for which tenders are now being called being the new station at Minnedosa, Manitoba. This will be a small building of exceptional design and of a size corresponding to the business done in the town. In addition to the building required for the actual business of the company, the C.P.R. is at the present time asking for tenders for the erection of the new railway Y.M.C.A. building at Cranbrook. This structure is to cost \$26,000, and will be very similar in appearance and design to the Y.M.C.A. building in Kenora. It will be of frame, however, and will be a little less expensive than the Kenora building.

* * *

CATALOGUES.

TURRET LATHES.—Gisholt Machine Co., Madison, Wis., Catalogue; size 8 x 10 in.; pages 64. This is the company's 1910 catalogue, describing and illustrating the Gisholt turret lathe and its accessories. Six views showing the increase in the size of these lathes from 1885, when the first one was built, to the present time, occupy two pages in the front part of the catalogue. These are followed by illustrations of the six regular sizes and the four big-bore lathes. There are also a number of engravings showing the different classes of work turned out on this lathe and installations in machine shops in various parts of the country.

THERMIT.—Goldschmidt-Thermit Co., 90 West Street, New York. Bulletin on repairing steel and iron rolls by the thermit process, illustrating the fractured rolls, the mold, the wax pattern in position, the apparatus ready for making the weld and the finished weld.

CHUCKS.—Cushman Chuck Co., Hartford, Conn. Condensed catalogue and price list for 1910 of Cushman chucks and face-plate jaws. Cushman chucks are made in a large variety of styles and sizes adapted to all classes of machine work and general manufacturing.

FORGE FURNACES.—Catalogue 8 from W. S. Rockwell Co., Hudson Terminal Bldg., 50 Church St., New York, contains data and description of Rockwell forge furnaces operated on oil or gas.

POWER PUMPS.—Catalogue No. 7 from Smart-Turner Machine Co., 191 Barton St. E., Hamilton, illustrates and describes the many styles of pumps manufactured by them to suit the purposes for which they are intended. These pumps use belt, motor, steam or gas engines as motive power as desired. A line of gas engines built by them is also included in the catalogue.

FUEL AND GAS BURNING APPLIANCES.—Catalogue 3 from W. S. Rockwell Co., Hudson Terminal Bldg., 50 Church St., New York, contains illustrations and descriptions of many of the appliances included in their extensive lines. Among them are high and low pressure oil burners, oil pumping systems, blowers, steam separators, pressure tanks, oil hose, etc. A number of valuable tables on melting points, weights of metals, S. G. of metals, etc., is also given.

RUBBER BELT CONVEYORS.—The Jeffrey Mfg. Co., Columbus, Ohio, have just issued booklet 35 which contains numerous illustrations and explanations of Jeffrey installations. Prices are given for the various designs. Prices are also given for rubber, leather, cotton and canvas belting.

METAL MELTING FURNACES.—The Monarch Engineering & Mfg. Co., Baltimore, Md., in a 32-page catalogue, describes its extensive line of crucible tilting furnaces for melting ferrous and non-ferrous metals, ladle heaters, core ovens, mold dryers and portable heaters for lighting cupolas. The crucible tilting furnaces are adapted for melting and refining foundry metals, both ferrous and non-ferrous, including brass, bronze,

BRUCE PEEBLES

Contractors to **& CO., LIMITED**
War Office, Admiralty, India Office, etc. **Edinburgh, Scotland**

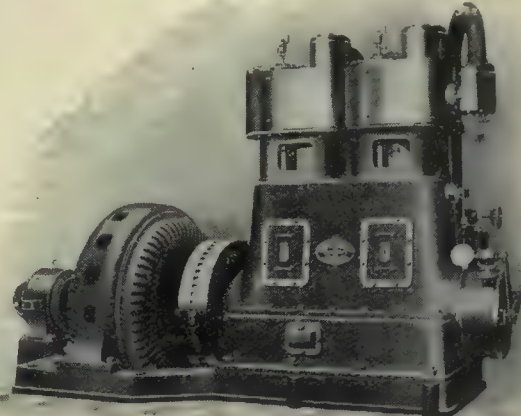

Direct and Alternating Current Dynamos and Motors
for all conditions of Service.

Sole Canadian Agents, **VANDELEUR & NICHOLS,** Dineen Building, TORONTO

HERE IS A SPLENDID

Sensitive Column Drill

For drilling holes up to 5/16 of an inch it gives remarkable satisfaction. The spindle has two speeds and is driven by a 1" flat belt. It is relieved of all belt strain, is counter-balanced and provided with means for taking up wear. As the column is graduated by a vertical line its full length, the centre of the table may be set in line with the spindle at any point of vertical adjustment. A cup centre is furnished with each machine as a substitute for the table in centring small work. Write for Circular and Price.



D. McKENZIE

9 Nottingham Street - - GUELPH, ONT.

BETTER RESULTS AT LOWER COST

can be secured for any class of castings by arranging your mixtures by analysis. Years of practical experience in foundry work are at your service when you consult with

The Toronto Testing Laboratory, Limited

18 SATURDAY NIGHT BUILDING, TORONTO
EXPERT FOUNDRYMEN, METALLURGISTS, CHEMISTS
TESTS OF METALS, FUELS, CORES, OILS, Etc., AT REASONABLE PRICES.

BABBITT METALS

FOR ALL PURPOSES

LUMEN BEARING COMPANY
BUFFALO TORONTO

copper, nickel, aluminum, tin, lead, ferro-alloys, manganese, silicon, vanadium, iron, etc. Among the furnaces shown is one of the pre-combustion tilting type, which is arranged with a supplementary rear chamber for receiving the flame from the burner, and which is deflected against a baffle block. An article on the use and abuse of crucibles contains pertinent information regarding the handling of pots, and should prove of interest to every foundryman. In addition, formulas of standard foundry mixtures are also included. The catalogue will be sent on request.

WATER TUBE BOILER.—The "Suckling" water tube boiler is the subject of a catalogue issued by Hawksley, Wild & Co., Sheffield, manufacturers of Lancashire, Cornish and multi-tubular boilers, feed water heaters, etc. The London, Eng., representative is T. F. Cowbrick, 49 Queen St., E.C. The "Suckling" boiler is fully described, the treatise being illustrated, making a very interesting publication.

PRESSURE GAUGES.—Bulletin 114 from the Bristol Co., Waterbury, Conn., deals with Bristol's recording gauges for pressure and vacuum. Full descriptions with prices, charts, etc., are given.

CONCRETE BLOCKS.—The Dominion Concrete Co., Kemptville, Ont., have issued an illustrated catalogue, on coated paper dealing with concrete blocks for construction purposes, also one on concrete culverts.

MECHANICS' TOOLS.—The Keystone Mfg. Co., Buffalo, have issued catalogue No. 18 describing and illustrating ratchets, taper sleeves, drilling posts, wrenches, etc., and giving price list.

LIGHTNING PROTECTIVE APPARATUS.—Circular 1132, containing 60 pages from the Canadian Westinghouse Co., Hamilton, contains a full description with illustrations, tables, line drawings and explanations of lightning protective apparatus and accessories.

MACHINE TOOLS.—The Burke Machinery Co., Conneaut, Ohio, have issued a 1910 calendar and price list of machine tools including milling machines, slotting attachments, saw grinders, sensitive drill presses, tapping machines, shapers, hydraulic pressure pumps, oil forges, etc.

BAR WORK.—Mussens, Ltd., Montreal, are mailing a neat booklet on bar work issued by Alfred Herbert. It describes the Patent Roller Steady Turner of the Alfred Herbert Hexagon Turret Lathe. It is printed on coated paper, and contains a great deal of information on turret lathe work. The cover is very attractive, being an arm holding a finished piece of bar work.

WEIGHT OR POWER.—Alfred Herbert, Coventry, England, have issued an exceedingly neat catalogue under this heading suggesting that there is a better factor than weight for determining the right value of a machine tool. These booklets are being mailed by their agents, Mussens, Ltd., Montreal. Milling machines of several designs are illustrated and described. The description is a reprint from an article in "The Engineer" under the heading "Purchasing Milling machines by Power."

RUBBER BELT CONVEYORS.—Booklet 35, recently issued by the Jeffrey Mfg. Co., Columbus, Ohio, contains numerous illustrations of Jeffrey installations and equipment. Prices are given for various designs and also for rubber, cotton, leather and canvas belting.

FANS.—Veritya Ltd., 31 King St., Covent Garden, London W.C., England, have issued booklet 608 dealing with fans of several types for summer use. They are designed to run at standard voltages, 110, 220, 480, 500, etc. Ventilators, desk fans, regulators, etc., are also described in the booklet.

COMPRESSORS.—A pamphlet from the Mesta Machine Co., Pittsburg, Pa., illustrates and de-

scribes a standard Mesta Corlius driven air compressor.

AMMETERS AND VOLTMETERS.—Bulletin 1181 from Westinghouse Electric & Mfg. Co., Pittsburg, Pa., describes portable D.C. and A.C. ammeters and voltmeters operating on the D'Arsonval principle with permanent magnet and moving coil construction.

HYDRAULIC VALVES AND FITTINGS.—Is the title of a 120 page illustrated catalogue just issued by the Watson-Stillman Co., 50 Church St., New York. Its pages list a great many types and combinations of hydraulic valves and fittings. Almost every page contains some hint or advice as to the best piping arrangements, what types or combinations of valves are best suited to certain work, how the valve arrangement may operate a number of cylinders or machines automatically, etc. Any engineer will find this book handy when figuring on new hydraulic installations or making changes on old ones. This book will be sent free to any one requesting catalogue No. 78.

STEAM TURBINE.—Circular 1094, 40 pages, from Canadian Westinghouse Co., Hamilton, is a very complete description of the Westinghouse-Parsons steam turbine, its origin and development. It is a very interesting and instructive treatise, fully illustrated.

* * *

BOOK REVIEWS.

"A Study of Base and Bearing Plates for Columns and Beams," by N. Clifford Ricker, Bulletin No. 35 of the Engineering Experiment Station of the University of Illinois. This bulletin contains formulas and tables for use in designing steel and iron plates of the usual forms. Copies of Bulletin No. 35 may be obtained gratis upon application to W. F. M. Goss, Director of the Engineering Experiment Station, University of Illinois, Urbana, Illinois.

CANADA'S LEADING TOOL HOUSE



Sizes 8 to 18 inches.
Flat and half round.

The DREADNOUGHT MILLING TOOL (The tool that supersedes the file)

It cuts 3 to 5 times faster than an ordinary file and with less effort, and outlasts 5 to 10 common files—can be re-sharpened several times without drawing the temper—it will not choke on soft metals and will take hold of a greasy surface. For LATHING work the Dreadnought is without a peer; it will finish the surface far superior to a bastard file and equal to the smoothest file. WRITE for CIRCULAR and PRICES.

ARMSTRONG



TOOL HOLDERS

ALL SIZES

"THE WORLD'S STANDARD LATHE AND PLANER TOOLS." Write for catalog and prices.

KEYSTONE RATCHETS

Morse Taper and Square Sleeve Ratchets, also Short Boiler Ratchets.
We carry a complete stock of Morse and Cleveland Drills.

Aikenhead's

AIKENHEAD HARDWARE LIMITED

17-21 Temperance St., Toronto



Making an Annual Saving of Thousands of Dollars

By Practicing Economy in the Locomotive Repair Shops, Thousands of Dollars are Saved—The Stock Room and Various Shops are Large Fields Where Large Saving of Waste may be Made.

By W. R. Smith*

THE subject upon which I have endeavored to compile this paper is a very broad one, in fact there are very few railway problems upon which there has been more comment and discussion than that of economy in locomotive repair shops. Possibly, on account of the Mechanical Department not being directly a revenue bearing department, greater attention has been paid to it as regards the organization in its various branches, than to any other department, in connection with railroad work. To bring this matter before you in detail would occupy a very considerable length of time, therefore, I shall only mention points which are of the greatest importance in connection with shop practice.

Storing Materials.

The first of these which I wish to bring to your notice is the storing of material, particularly heavy material, such as tyres, boiler plate, tubes, bar iron, etc., etc., all these should be located as near as possible to the shop in which used, and stored in properly erected buildings or racks, suitable for the purpose required, thus reducing delay on the part of the shop staff to a minimum, and at the same time placing such material under cover that would otherwise be subjected to atmospheric conditions, causing the material to depreciate in value, on account of corroding and pitting, thus reducing the length of service and thereby increasing the cost of the manufactured article. The buildings referred to should be thoroughly equipped with small cranes or lifting devices, to eliminate hard labor and facilitate rapid handling. The use of magnetic power on locomotive cranes now in use in the majority of modern plants, has proved very effective, and has been found to be a labor saving device. It would not be an extensive plant that would not require at least twenty men to perform duties of this nature, without proper facilities, which could be handled by the use of a crane of this type with about five men, effecting an approximate estimate in wage economy of about \$8,000 per annum.

You will, therefore, see that the saving would aggregate a much higher figure than would be considered credible by those not conversant with engine repairs. There is one other point on the material question, through which the mechanical department can be subjected to numerous inconveniences and disadvantages, detrimental to the working progress which of necessity terminates in increased expense; I speak of the purchasing and supplying of the proper quantity and quality of material at the required time, it being a very essential feature in economy. In this particular line of railway business, it appears to me, after personal experience of several years with four different railroad companies, that if those in authority in such matters, acted as far as consistent in supplying the make or quality of material specified by the head of the mechanical department, it would assist materially in economy. It can be readily understood that it is practically impossible for the latter to obtain the best results, in frugal efficiency, without the support of the purchasing department. The fact cannot be denied, however, that cases do occur, through some

neglect or oversight on the part of the mechanical department, in not advising the stores or purchasing officials of the consumption of an unusual amount of a certain class of material, or the necessity on the part of the latter to place an order for a commodity which it has not previously been customary to carry in the ordinary stock, thus placing that department in an unfair position through not being allowed sufficient time to obtain delivery.

Tracing Orders.

One matter to which strict attention should be paid is the tracing of orders for material after being placed. I could relate instances where it would be impossible for a mechanical department to correctly account for excessive charges through failure on the part of a manufacturer to supply material within a reasonable time. As we know the manufacturer's tendency is to grasp all the business possible, with the result that it frequently takes double the necessary time to get deliveries made. I have known cases where six months has been taken where thirty days under ordinary circumstances should be ample time. This is an expensive proposition and one that should not be tolerated by a railway company, as the ultimate cost is perhaps one hundred per cent. more than the actual value. This and other questions of a similar nature prompt me to state that the most improved business methods possible to adopt, relative to these three departments, are in the best interest of the company.

In referring to what is conceded by many to be the principal cause of high figures in mechanical labor, being that of the present standard rates of wages, we are all aware that conditions in this particular have made a wonderful advance in the past ten years.

Still expensive locomotive repairs must not always be solely attributed to this fact, as there are comparisons for consideration in what might be termed the ancient and modern methods in applied mechanics found in shop practice.

The rapid strides accomplished in the mechanical sphere of late years are more than equal to those which have taken place in any one particular in railroad records.

It is well said that time is money, and in this age of comparison, rapidity should be the point at issue in every performance in locomotive repairs, in order to keep pace with the records which are now being continually made, in modern shop efficiency.

I do not purpose entering upon a discussion of the numerous improved appliances, but by way of comparison I remember only a few years ago, in what was at that time one of the largest shops in Canada, where an employe welding boiler tubes after ten hours of strenuous labor would have about 100 tubes welded.

To-day it is possible by the use of certain machines, without any more exertion on the part of the operator, to weld 600 tubes in the same length of time.

Increase Efficiency of Machinery.

Take for instance the enormous amount of manufactured material produced by the use of the modern blacksmith shop machinery.

Then consider the modern moulding department as compared with that of ten years ago, and we find an in-

* General Foreman, Canadian Northern Shops, Winnipeg.

crease in the output ranging from 100 per cent. up, and not only a higher grade of casting, but more accurate, requiring less machine work, thereby reducing the cost of manufacturing in every particular, due to the use of moulding machine.

The same progress may be applied in speaking of the boiler shop, as 75 per cent. of the operations which were manual labor, a few years ago, are now minor details, through the use of hydraulics and compressed air.

The tool and machine shops have, with high speed steel and high grade improved machinery, shown no small display in the advanced superiority of shop efficiency, and in view of the existence of such conditions, the fact, beyond a doubt is clearly demonstrated, that the adopting of modern methods and such machinery, is of vital importance to a mechanical staff who are expected to compete with the competitors of this decade, for never in the history of railroading has there been such efficiency developed in railroad mechanics, as in that of the past ten years, which goes to prove that all companies to-day occupying an important position in the handling of freight and passenger traffic, must of necessity keep their motive power in first class condition, there being nothing that will reflect discredit upon a company quicker than neglect in this department.

By this it is understood that shop equipment for locomotive repairs is an essential question and should warrant due consideration, in order that economy is brought to prevail, which necessitates close inspection of all details in daily shop practice, as the small matters count in the question of time and labor, which is money, and in the performance of such duties, system is required to be observed in every particular governing the delivering of material to the respective departments, also the disposing of scrap materials, and the various relations between the foremen, in order that the work in each and every department, be advanced to the best interests of all concerned.

Checking Costs.

Another important item in this connection, is the checking of the costs of work performed each day.

In order to have correct information with reference to the cost of locomotive repairs, it is necessary to obtain a daily check, to prevent any mistake being made by the employees on their time distribution slips, which are commonly used in time-keeping in locomotive repair shops.

This places the foreman directly in charge of engine erecting, or machine work, in a position to explain why certain repairs on any particular engine, should cost more than the same repairs on another engine of the same type.

To obviate such difficulties I am convinced that a system adopted about a year ago by A. Shields, Master Mechanic of the Canadian Northern Railway, which is known as the "Engine repair account" and is only used in general repair shops, or what is generally termed "Back" shop, is one of the most convenient methods to be found in checking cost of engine repairs, i.e. from a mechanical department's point of view.

It must be admitted that it entails extra time in Stores' Accountant's office.

It is a system of itemized charges against repairs by the use of consecutive numbers, which are used to specify every piece of work on an engine, and is as follows:—

Accounts—Repairs to Engines.

- | | |
|----------------------------|-----------------------------|
| 1. Stripping | 5. Put on frame R. or L. |
| 2. Repair rods | 6. Remove cylinders No..... |
| 3. Take off frame R. or L. | 7. Apply cylinders No..... |
| 4. Repair frame R. or L. | 8. Boring cylinders No..... |

- | | |
|--|---|
| 9. Bush cylinders No..... | 38. Steam and exhaust pipes |
| 10. Repairing cylinders No..... | 39. Dry pipe and throttle rigging |
| 11. Firebox—new or repairing | 40. Valve seats, bushes and chests |
| 12. New front flue sheet | 41. Pistons and crossheads |
| 13. New back | 42. Guide bars and blocks |
| 14. New inside sheets R. or L. | 43. Spectacle plate |
| 15. New outside sheets R. or L. | 44. Repairing valve gear and motion |
| 16. New door sheet | 45. Driving tirts, wheels, crank pins and axles |
| 17. New wagon top | 46. Boiler mountings, injectors, pops and lubricators |
| 18. New face plate | 47. Lagging |
| 19. New throat sheet | 48. Jackets |
| 20. New crown sheet | 49. Piping |
| 21. Boiler | 50. Engine bell |
| 22. Smoke box—new or repairs | 51. Headlight |
| 23. Washout plugs and holes | 52. Smoke stack and base |
| 24. Tank repairs | 53. Front end ring and door |
| 25. Remove flues | 54. Expansion and running board brackets |
| 26. Repair flues | 55. Springs and spring riggings |
| 27. Replacing flues | 56. Wheeling and putting up binders |
| 28. Front end arrangement and netting | 57. Pilot, buffer beam brackets and front coupler |
| 29. Ashpan and rigging | 58. Cab running boards and deck floor |
| 30. Air pump, air signal and steam heat | 59. Sand box, dome casing and hand rails |
| 31. Driving brake and rigging | 60. Painting engine and tender |
| 32. Driving boxes, hub liners and eccentric straps | 61. Tank frame repairs and draft gear |
| 33. Repairs to shoes, wedges and horn blocks | 62. Trucks and brake rigging |
| 34. Deck casting | 63. Miscellaneous |
| 35. Deck beam brackets and wind sheets | |
| 36. Hanging motion and setting valves | |
| 37. Repairs to engine trucks | |

Stripping an engine is account No. 1, repairing rods account No. 2, and so on; the highest number is 63, it being a miscellaneous account which covers all extra or unusual charges.

It is worked in this way:—

Presuming a machinist has worked all day on boiler mountings (account 46). On his time slip he writes the date, engine number and 9 hours account No. 46, which is all that is necessary.

Each morning all slips are collected from ticket boxes and charges recorded by the mechanical department, previous to sending slips to the timekeeper.

The form used for this purpose has the dates printed on the top line and the account numbers on the right side, so that all that is necessary, is to place the amount charged under the date and opposite the account number.

There is one form for each engine in the shop for each month.

By this you will understand that at a glance, the cost of labor on every piece of work in the shop can be obtained daily. Charges for material, of course, can only be got at the end of each month, when accounts are closed by the stores department.

It is understood of course, that due credit is received for scrap material.

Some companies use the shop order system: In this, every piece of work has a different number, being confusing on account of high figures, which would run into the thousands every month.

With the account system, a certain piece of work on every engine is always the same number, with which the employes become familiar and thus avoid mistakes on their time slips.

It may be possible to improve on this system, but I must say, if properly carried out, it is the best arrangement in the interest of the mechanical department that I have used.

Value of Trade Papers: How to Derive Benefit from Them

The Greatest Loser is the Reader who Carelessly Thumbs over the Pages—Technical and Trade Papers Should be Handled Methodically.

By One Who Reads Them.

I OFTEN wonder what subscribers and others who receive various trade publications do with them. I know of some who "get them," look them over carelessly and throw them aside; their disposition, mental and other needs, possibly their capacity for acquirement of features of value, not being sufficiently pronounced to force them to a realization of the wonderful worth to-day incorporated in these publications—and in this I do not mean wholly to indicate the reading matter or editorial columns, for, from my point of view, there is not a single column in a trade paper of the present time that is uninteresting.

It is astonishing when we consider the value given to the assembled sheets of paper. How we must praise the modern progress made in the art of printing and illustrating! How few understand, when they subscribe for the average trade paper and pay the price asked for the regular sending of the publication, that their subscription, instead of meaning a profit to the publisher, actually means that the publisher is to lose money in supplying it, for the service given by the leading trade papers now costs more than the return as represented by the price of the subscription. Thus the subscriber gets something, yes, much, for nothing, but still the publisher willingly bears his loss, as he needs readers to give value to the advertising columns. In other words, circulation counts, and it counts for a very great deal from the publisher's standpoint, even though the advertisers should always reserve the right, and persist in it, to criticise the quantity in a demand for quality. Quantity without quality will bring disappointment. That, however, is another story.

The Careless Reader the Greatest Loser.

A subscriber who receives his paper, carelessly glances over it as he applies thumb pressure to shoot the leaves along, stopping only to casually and quickly read a paragraph, a note here and there, does not do himself or the publisher justice. He will be the greatest loser. The publisher will get just as much money from him, but he will fail in acquiring the exceedingly valuable fund of information the publication brings to him. And the more of this information he gleans the higher and better will be his appreciation of the publication. The faithful, energetic editors work hard to have the pages up to date in the data they carry. Type forms and illustrations are carefully studied in order that the appearance may be of the best, each thoughtful attention in this direction being intended to hold interest on the part of the reader. Many fields have been searched for the actual news and scientific information placed before the subscriber by the editors, who are very materially helped on the larger number of pages by the men who write and plan the advertisements.

The subscriber who looks upon the advertising pages of trade publications of to-day as tales of purchased space makes a very serious mistake. These advertisements are developed by able minds in every part of the country, each one of which seeks to educate the subscribers of the trade publication to the latest and best practice in a particular line. Publishers of trade papers have high morals; they scan every bit of copy that comes to their office determined that their readers shall be protected from advertisements that make false claims. Occasionally a fake assertion that has a new feature may

creep in unknowingly, but as soon as the deceit is made apparent the columns of honest papers are forever closed to that business. And the average reader does not know how many advertising men there are who are cautioned not to call on this or that concern whose business by the publisher is deemed undesirable.

Handling Trade Papers Methodically.

Let me advocate a higher appreciation of the trade paper. Let me tell of one progressive company and its realization of the importance of thoroughly reading what the editors and others have to say in these factors of this modern industrial growth. The company to which I refer receives a very large number of trade and technical papers, but it makes easy the reading, handling and disposition of them. They are all first handled and opened by the one who distributes them to the department or employe most vitally interested in the various publications. For instance, an engineering publication first goes to the company engineer; a paper that has to do with power is sent to the mechanical department, as are also machinery papers; the electrical papers go to the electrical engineers, except papers that carry patent references, which first go to one who scans the patent report to see if any of the late issues have to do with fields in which the company operates, and if so, this department immediately sends for these patents of interest; papers that are associated with the chemical, electrochemical, electrometallurgical field all have their readers; automobile publications go to various departments, as do those devoted to military affairs, while the same may be said of marine, paint, power boat and similar fields; all the publications go regularly to individual readers. It is well understood among the employes of this company that they are, in a certain sense, responsible for reading these publications and getting from them everything of present or future interest to the company's affairs. Articles of interest are abstracted, and cards in the following form are made out for filing in a well planned system:

Title
Publication
Date
Author
Remarks
File under

All such cards are sent to the stenographic department and filed. Subjects having any relation to the field in which the company sells its products, or to the use and application of its products, are most carefully covered, so that, for instance, should the company at any time desire information on any of the many subjects it would only be necessary to call for the cards on file and direct that the publications containing the articles or references listed be brought up from the basement for review. To facilitate this review, it may be stated that all the trade papers received in the English language as well as foreign languages are most carefully preserved by means of a filing system, to which a goodly space has been given in a spacious basement, the plan being to bundle each year

of the various publications by themselves. Clipping of the publications is prohibited.

In order to have the publications distributed and pass from department to department, so that all may see them, discover new features or absorb the information of articles marked, each publication is first stamped with the initials of the several readers who are to see them in the course of their transit through office and works, the stamp used being something like this :

J.U.D.....
K.W.S.....
D.S.A.....
P.L.M.....
B.G.R.....
C.D.F.....
T.R.E.....

A list of publications received and the readers assigned is in possession of each department, so that the course to be followed in sending a publication forward is so well known that it soon becomes a matter of form,

each reader checking on the dotted line following his initials. The sales department, the financial department, the chemists, the superintendent, the engineer, the electrical engineers, the executive department and others are all alert to new things, and it may be guessed that a fund of information is gathered. Then, too, it makes possible the reading up on things in which to-day a company seemingly has little interest, but which is conceived to possess future features of possible value.

Every Item Preserved.

By this system, every item printed in the publications read is preserved, so that when the day comes when the concern wants information on the subject it will only have to turn to its filing system to review all that has been printed. This is a factor of wonderful value, it is believed, as it makes possible a general oversight aided by the many bright minds that write for the publications. It will thus give life to the writings of many editors long after they may be dead.

If one will only consider the immense amount of capital and human energy now devoted to preparing and printing the trade papers which serve as guides in their respective fields, I am very confident there will be a general increase in appreciation of the service performed. It is but fair to admit that the principal trade papers are always ahead of their readers in information. They must be so, for they are teachers; they tell us of the newest and best things, of the latest practice in many lines, and it is indeed a dull reader who cannot profit by perusal of them. If subscribers will thus cherish their trade papers I am sure there will be an awakening as to their value and of the good they do, of their great general worth and assistance. When subscribers thus esteem their technical and trade papers, they will deserve to have their names enrolled on that monument of quality instead of being considered quantity, which, as I have said, is another story.—Iron Age.

Let us Look Technical Education Square in the Face

Co-operative Education Combining Practical Shop Training in the Shop with the University Course is Suggested as a Solution—It Would Greatly Increase the Value of the Apprentice to the Manufacturer.

By Robert Patterson *

Being much interested in the training of apprentices for the mechanical trade, also in the education of the younger mechanics, any papers, or discussions on the subject, have always been of great interest to me, and when asked to write a paper on some subject I selected this one, not, perhaps, so much with the idea of imparting much new information, as with a view of bringing before you, a subject that is of great importance, requiring careful study and attention of the industrial community of Canada, and those responsible for the proper education of Canadians to-day.

I believe the most desirable for present day needs of Canada is a combined practical and technical education. This would meet the present urgent demands, and would create a number of 'educated mechanics who now receive little or no technical education.

Papers without number, and discussions without end, have been dealt with, to try and settle the question, as to whether the university educated man, or the practically educated man has been the most successful, in giving the best results to their employers and the mechanical world at large. Although, there have been

numerous university graduates, who have shown great brilliancy, and accomplished much, yet the practical man has not by any means been outclassed; as to-day, he is probably holding more general positions of trust and responsibility, and quite as many high positions, as his university graduate competitor. With the combined practical and technical education, we have men who are thoroughly conversant with shop practice, labor conditions, organization and the practical handling of men. This, the university graduate does not learn at college or university and in that respect, is much inferior to the man who is technically and practically educated.

However, it is not this phase of the subject I wish particularly to deal with, but technical education of the average mechanic and system of education by which same can be most successfully accomplished as to thoroughness with economy of time.

In this young and growing country of ours, the rapid development of steam and electric roads and the vast increase in manufacturing industries have created a demand for increased and rapid facilities for doing work, and also for producing mechanics able to keep pace with such development. From all appearances, the future will create a still more urgent demand. To meet present and future

* Master Mechanic G.T.R. Shops, Stratford.

requirements, a quick and thorough system of education will be necessary to provide technically trained men.

Men at the head of our public educational system of to-day, have already realized this, and as a result, the boys in our public schools are taught manual training. The system should be in force in every centre in the country. It would greatly help parents and guardians by enabling them to judge of the fitness of the boy for his future profession, mechanical or otherwise. Without this opportunity of judging a boy's qualifications, it is often very difficult to determine what a boy's profession should be. With manual training in his early days, however, it gives additional opportunity to learn whether the boy would be more fitted for engineering or some of the other learned professions. It is a great assistance to the boys who intend to enter the mechanical profession. It teaches the necessity of carefulness and correctness with application of thoroughness in their work that they may attain their desired ends; also it gives them self reliance and leads them to appreciate honor and have an honest pride in good work done by themselves. It also teaches them to have a desire and respect for all honest manual labor, an attitude of mind which will produce a beneficial effect on the country at large.

At the present day in Canada, it too often happens that from lack of opportunity and facilities, when a boy leaves school, he is unable to continue his studies. This unfortunately results in the education which he already has becoming warped or lost on account of its not being further developed. In a few years, with few exceptions, he is thrown on the world as a journeyman mechanic with less education than when he started to work and practically no ambition to obtain it.

Training Men in the Shops.

To overcome this state of affairs, what step should be taken to make mechanics better acquainted with the technical side of their professional education? One method is for employers to establish a system of technical education in connection with their works or industries. It is of the first importance to interest manufacturers in the cause of such education. The manufacturer will be the first to be directly benefited as in all branches of industries, we would have a corps of trained young men with more intelligent interest in their work seeking all the time to improve in practice and desiring to become eligible for promotion.

A number of corporations in the United States and Canada have already established technical schools in connection with their shops. The Grand Trunk Railway System in Canada has been a pioneer in this respect and now the C.P.R. also has a school where technical training is given its apprentices. In the case of the Grand Trunk, it was found that to meet the ever increasing demands for skilled and thoroughly trained mechanics, it was absolutely necessary to establish a training school. The boy who had to leave school with only the rudiments of an education from force of circumstances and begin work, had little to look forward to in the matter of education after he once left school. With this system of education, which has been adopted by the Grand Trunk Railway, all apprentices are now fortunate enough to be able to secure a good practical, as well as a technically combined education.

G. T. R. System.

In explaining this system to begin with, an apprentice has to be 15 years of age or over before he can enter the service of the company as an apprentice. He has to receive a medical certificate from the company's doctor certifying that he is physically fit to do the work required of him. He is then put through an examination in the of-

fice and practically had to pass an examination in different subjects that would entitle him to enter the first form of our collegiate institutes. He has also to pass an examination to see if his hearing and eyesight is sufficiently good to follow the business.

If he is successful, he is then admitted as an apprentice to the works and is provided with a text book for his instruction and guidance. This book contains examinations for the apprentices for each promotion he takes while serving his apprenticeship. For instance, if an apprentice is being promoted, say from the boiler shop or pipe shop to machine shop and is going to be placed on a drilling machine, he is examined on how this machine should be operated and he has to theoretically explain the method of operation so that, with very little practical instruction, he is able at once to start in and do good practical work but should he fail in these examinations, he is sent back to the shop he came from and the next boy in turn is promoted. He is given another chance, after his first failure, say in a month's time, and if he fails again, he is dismissed from the service for the reason that he is considered either not sufficiently intelligent or too indifferent to make a good mechanic. This practice is followed during his five years' course.

Advantage of Apprenticeship System.

One of the great advantages of this system is that it gets the apprentice thinking and leads him to reading up in line with his work. It is compulsory for all apprentices to attend evening classes two nights per week during the term, at which practical mechanics, mechanical drawing and machine design are taught. An examination of the apprentices takes place over the entire system once a year and examination papers are prepared in which all first, second, third, fourth and fifth year apprentices compete, that is, all the first year apprentices on the system in one class, all the second in another, and so on.

Class prizes are given, also individual prizes, and the keenest rivalry is exhibited, not only among the apprentices individually, but among the different shops as each shop is desirous of having the honor of obtaining the highest average number of marks at the examination.

Remuneration.

At the expiration of apprenticeship before an apprentice becomes a journeyman, he has to undergo a thorough examination to see that he is competent in all the branches of the trade he has been learning. After successfully passing this examination, he is furnished with a certificate of apprenticeship. During his five years' apprenticeship, the sum of 5c per day is retained from his wages. This is refunded to him and a bonus of \$25.00 from the company is given him. That with his month's wages entitles him to a snug little sum on the day he completes his five years' apprenticeship. In addition to these privileges, the company has arranged that two scholarships be given each year for competition amongst the apprentices so that the fortunate ones are entitled to a four years' free course at McGill University in any of the branches of engineering or transportation work.

A Co-operative Course Necessary.

But however, I would like to add to this and thereby make the system of training more complete. I would like to see a way opened up at our universities so that young men who have gone through their five years' training as apprentices and not fortunate enough to have won a scholarship entitling them to the four years' free course at McGill University in Engineering or Transportation, might be able to obtain further technical education by a short course, say of one year at our Universities at as low a cost as possible to the student. In this course, he should have the privilege of making experiments, tests,

etc., and a young man who wishes to succeed and obtain a more advanced education, could do so. If such a system as we have on the Grand Trunk Railway were applied to every manufacturing and industrial establishment, the apprentices' rebate and bonus at expiration of his apprenticeship would partly enable him to carry this out and would make him more diligent, attentive and ambitious to become not only a good practical but technical mechanic.

Government Should Provide Schools.

Again, there are some factories or industries not provided with rooms or appliances for education of apprentices or from other causes, could not do so. In these cases, where occurring in towns or cities, the government or municipality should step in and provide night schools, thereby giving them the chance to acquire better technical education to help them in their career through life. As a rule, they have not been able to go very far in their High Schools before going to work, but at least they should have the same opportunities as that of their old school mates destined for professional life but not called upon to leave school at such an early age.

Our High Schools and Collegiate Institutes with all their facilities for education are practically only used six hours per day for five days per week. Why should not these be opened to the young mechanic at night time so that he might further pursue his studies and be educated for his life work. In the majority of cases, good laboratories are used in connection with most of these schools and should be at the service of those who wish to study along that line.

The government should be prepared, and I think it would be the quickest way to get at it, to assist the manufacturers in having the use of these schools.* For instance, any manufacturer giving free tuition that could show an attendance of so many employes ought to receive remuneration so as to bear part of the expense of teaching, etc.

Scholarships assisted by government grants should also be given for these shops, which would entitle the successful student to a scholarship at the university for the one year's short course which I have mentioned. In the larger cities, the government ought to support the universities to such an extent that they would be so equipped so as to take in all mechanical and engineering branches and where sufficient number would make request and where sufficient students would attend to make it successful, all other industries could be represented at the university.

I think a short course at the university as mentioned by me would be of incalculable benefit, for in addition to the actual information which a young man would get in connection with his work which he would be able to take in more rapidly on account of his five years' practical and technical training, he would receive general improvement on account of coming in contact with men of learning and culture for a year. This would not take him so long from the practical work as the four years' course at present, also after the four years' course, he would find so many changes that he would require to go over a great deal of the practical ground again.

To ask that the government should assist in the higher education of the mechanic is not more than right. The government provides colleges for the agriculturist with long and short courses for the farmers, Normal Schools and Faculties of Education for education of teachers in Agriculture and Domestic Science, grants to the universities for student courses in Arts, Divinity, Medicine,

* On the Grand Trunk, all tuition is free for the apprentices, they not being under any expense whatever for the education which they get and are paid substantial wages during the time they are working in the shop.

Law, Engineering and Mining are also given. Why should a short course of one year be instituted for finishing the education of the working mechanic. We may for all we know have amongst our young men, mechanics or engineers whose genius might equal that of some of the most celebrated of modern times if they only had a chance that a little further education might give them. Let us endeavor to give them that chance not only for their own advantage but for our own as employers and for the betterment of mankind in general. The young mechanic deserves every opportunity of pushing his way in the world as much as the literary man, the minister, the lawyer, doctor, or any other professional men. The educated mechanic is one of the main stays of our Dominion, like the Village Blacksmith of Longfellow:—

"Each morning sees some task begun
Each evening sees its close;
Something attempted, something done,
Has earned a night's repose."

In conclusion, I would say that if we combine the practical and technical training of our boys and young men, we would have the best average mechanic who will meet all requirements of these times of rapid progress and development and we will I believe, solve labor problems to a great extent.

WOMEN AND CHILDREN IN FACTORIES.

A bill is before the Quebec House of Assembly entitled "An act respecting the working hours of women and children in certain factories." Factory inspectors have brought to the attention of the powers that be, the fact that women and children are working eleven hours a day in many places. These hours are too long. There is no need to mince matters—the fact remains, and the only excuse for these long hours seems to be the fact that they are necessitated if sixty hours a week are to be put in and the Saturday half holiday stand.

But why sixty-five hours? Are not fifty-five or even fifty hours plenty? It would not increase the cost of production by any appreciable amount if the hours were shortened and more hands employed. There are still lots of willing—and efficient—workers ready to work if employment can only be had, and in view of this we feel that Quebec has in mind a progressive step in the question of labor legislation.

Large employers of such labor in the Province of Quebec are opposed to the act on the grounds that it would place them at a disadvantage when compared with the manufacturers of other provinces whom the act will not involve. This is a good point and worthy of consideration and brings us to the statement that we believe the act should be made general by emanating from Ottawa. Whatever is wrong about existing conditions in Quebec is wrong about similar conditions in Ontario or any other province and it is up to the Dominion government to investigate and right matters.

We won't go into details regarding the detrimental features of women and children working in factories—they are fairly well known to most of us. The unfortunate thing is that they are compelled to work to live and, as we said before, it is us to our general parliament to see that conditions under which they do work are made as comfortable and as favorable as possible.

It may be that the matter will have been brought to a head—in Quebec at least—by the time this appears off the press. If so we trust that our hopes will be realized and our women and children will not be forced to work eleven hours a day in order to "hold their jobs."

Production Greatly Increased by High Speed Steel

The Proper Treatment of High Speed Tool Steel will Help in Obtaining the Full Efficiency—Forging, Hardening and Sharpening.

By Samuel K. Patteson.

While practically every machine shop owner, foreman, or operator is familiar with the fact that great strides have been made in the production of steel for cutting tools, they are totally ignorant of the means and methods of such production, a knowledge of which would perhaps result in more intelligent use of the tools.

Crucible steel, or the fusion of iron and charcoal in crucibles, has been known from the earliest times, in fact

planer of a chip 4 inches broad from an armor plate, at a speed of 12 feet per minute, and turning mild steel bars at a speed of 150 feet per minute, with a cut 3-16 in. deep and the feed 5 inches per minute. In this latter case the tool worked from 7 to 8 hours without grinding. Instances have also been cited of cutting speeds up to 500 feet, and grey iron drilled at 25 inches per minute. Comparing these results with the speeds of 25 to 50 feet per minute of the old

and in combination with these two are variously used molybdenum, tungsten and chromium, either singly, in pairs or all three in conjunction, and for the benefit of those not entirely familiar with the subject, it might be well to give briefly the various influences of the different metals.

The toughening effect of carbon is well known, as is also the fact that too high a percentage of it will make the steel brittle. Percentages ranging from 0.35 to 0.9 or 1.0 give a very tough steel, and the highest cutting efficiency. Over this percentage the tools are found to be unsatisfactory and are liable to break when the cutting is not continuous, as in planing.

With chromium at percentages of from 1.0 to 6.0, varying results have been obtained. Thus, a low percentage tends to toughen the steel, and tools made from it give excellent results on mild steel and gray iron, but their efficiency was lowered on harder steel. As with carbon an increased percentage of chromium gives a harder steel, but for best results, there must be a decrease in carbon for a corresponding increase in chromium.

Vanadium as a substitute for chromium is not satisfactory, owing to the fact that, while the cutting qualities on medium steel are about equal, the increased cost renders it inadvisable.

Tungsten in High-speed Steel.

Nearly all of the high speed tool-steels now on the market contain tungsten in varying proportions. In one series of experiments on record, the percentages varied from 9 to 27, and it was found that when from 9 to 16 p.c.

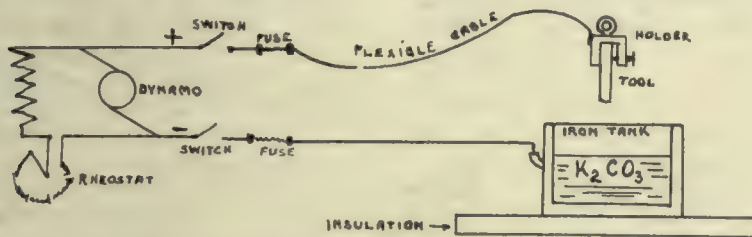

Fig. 1.—Arrangement of Iron Tank for Heating Tools Electrically.

it is a matter of record that the Chinese made steel in this way prior to the Christian era. So far back into antiquity does the beginning of the process go that it is impossible to accurately trace it, but it is hardly conceivable that the ancient races used anything but tool-steel in the execution of the carvings on the hard stones which record their history. It would seem therefore wonderful to the ordinary mind that while the process of making crucible steel was known so long ago, the method and process of manufacture is practically now on the same lines as it was in the old times.

The most important discovery in this line was made by Robert Mushet some forty years ago, who produced a steel containing a percentage of tungsten, and called Mushet steel, which marked a very considerable advance in the manufacture of tool-steel, and for a long time held the first place in its class. Since then practical and scientific men have given their time and thought to experiment and research, with the result that remarkable advancement has been made. Not only has the field of improvement in tool-steel been advanced, but as a result of better grades being produced, experiment has shown that machinery for metal-cutting can be speeded up to almost unheard of velocity, with a consequent increase of work and great economic saving. There are records of work done by modern high speed tools that are almost incredible, as for instance the removal by a

tools, shows what startling progress has been made.

With these results before them, it is hardly to be wondered at that the majority of operators have embraced the opportunity presented for utilizing such an economic development, and the growth in the use of high speed tool-steel has been almost in a ratio with the increased speed possible as a result of their use. This can be more readily understood when it is recalled that for many years prior to its introduction, there had been but little progress in the manufacture of tool steel or improvement made in its cutting qualities. To those practical minds that were given to thought, must have occurred the

hope that eventually a steel of greater cutting possibilities would be produced, and as a result more work, with a corresponding decrease in cost, would be obtained. The developments of recent years have, in a measure, realized these desires, and the wide awake operator of to-day is availing himself of the opportunity.

Iron and carbon are the principal components of modern high speed tool-steel.

was present, the cutting efficiency was very high, but the steel was brittle, and no better results were obtained by increasing the tungsten over 16 p.c., which seemed to be the limit for best efficiency. Between 18 and 27 p.c. they became softer and tougher, the tools cutting cleanly, but liable to break down easily.

It has been found that where a large percentage of tungsten is necessary to

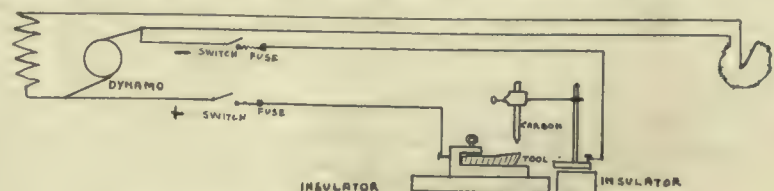

Fig. 2.—Second Method, Utilizing the Electric Arc.

give a high speed steel, a much smaller percentage of molybdenum will give equally as satisfactory results, and in addition steel containing the latter does not require as high a temperature for hardening, to obtain the greatest efficiency, about 1,000 deg. C. being sufficient, the tools losing in efficiency and life at higher temperature. Molybdenum is, however, comparatively costly, and while slightly greater efficiency is obtained in tungsten steel by the addition of from 0.5 to 3.0 per cent of this metal, the results obtained are not proportionate to the cost.

Silicon has been used in percentages up to 4.0, and up to about 3.0 per cent. perceptibly hardens the steel and increases the efficiency on hard materials. Above that point, however, there is a rapid fall in efficiency.

Stands High Temperature.

Now the prime requisite of a high speed steel is that it shall be capable of withstanding the high temperatures generated by friction between the tool and the work as a result of rapid cutting. Ordinary steel may be made intensely hard by heating and tempering, but as the frictional temperature increases and reaches approximately 500 deg. F., the hardness rapidly departs. Thus it is necessary, in order to prolong the life of the tool to run at a limited cutting speed, and thus reduce the friction and consequent heating. On the other hand high speed tools are efficient at greatly higher temperatures, even to 1,200 deg. F., and, as the hardening temperature is carried above the critical point, and rapidly cooled, so will the frictional temperature the tool can stand be correspondingly increased. At a temperature of about 700 deg. C. steel undergoes a transformation, and it is with the object of retarding this that such elements as those mentioned above are used. Ordinary carbon steel, or the old self-hardening steels, required great care in heating, as, if either were heated above about 1,600 deg. F. there was great danger of burning and resulting impaired efficiency. In the high speed steel, however, temperatures may be carried much higher, approximating the melting point, it being almost impossible to reduce efficiency by burning. The heating and tempering of high speed steel is, however, an important phase of the subject, and a more than superficial knowledge of it should be sought by those who handle tools of this character.

After the steel has been worked into bars, annealing is probably one of the most important processes through which it goes, and thorough and accurate annealing is an important factor in the production of satisfactory high

speed tools. It not only insures a uniform molecular construction, by relieving internal strains due to casting or tilting, but leaves the steel soft enough to be easily machined into any form.

The three principal stages of forging, hardening and sharpening high speed tool-steel for use vary in practice and with regard to the type of steel used, but for general use may be summarized somewhat as follows:

Forging.

It is an absolute essential that the bar be heated thoroughly and evenly, to the centre of the bar, before cutting off. If this is not done and it be cut when cold, end cracks are liable to appear which may gradually extend and produce considerable trouble and loss. After cutting, reheat as before and be sure it is heated throughout, otherwise, if the centre be cold, the steel will not draw or spread out equally, with cracking as a probable result. The steel may be raised to a yellow heat or about 1,800 deg. F., when it becomes soft and is easily forged. When it cools to a good red, or about 1,500 deg. F., forging should be discontinued and the piece reheated. After the required shape is obtained, lay aside to cool.

Hardening temperatures vary in accordance with the class of tool to be dealt with. Thus for planing, turning or slotting tools to be hardened, the point or nose only is heated gradually to a white heat, just short of melting while for gear-cutters, twist-drills, taps and reamers a temperature of about 2,200 deg. F. is required. If the point of the turning or planing tool should become slightly fused, it does not matter, for after cooling in an air-blast, it only requires grinding to restore it to usefulness. Another method of treating these latter tools, is to grind to shape on a dry stone, or emery wheel, after forging, and when cold, after which it is heated just short of melting and cooled as before. Instead of the air blast for cooling the oil bath may be used. In this process the steel is raised to the white heat, without melting, and cooled in an air blast to about 1,700 deg. F., and then immediately immersed in a bath of rape or whale oil. The rough grinding to shape of the tool before heating is advantageous in this latter process, especially where tools with a sharp edge are desired for turret or automatic lathes, brass workers or finishing tools, etc.

Electrical Heating.

In this connection the electrical heating of tools has become an important factor and either one of the following two arrangements may be used for turning or planing tools with satisfac-

tory results. An arrangement of an iron tank containing a strong solution of carbonate of potassium, a dynamo, rheostat, switches properly fused, etc., is shown in Fig. 1.

In this method the current is turned full on and the tool lowered into the liquid until the part to be tempered is immersed. On contact with the solution of K_2CO_3 the electric current is completed, and intense heat is generated, and when the tool is sufficiently heated, the current is shut off, the bath serving to chill the steel, thus obviating the use of an air blast.

The other method is by utilizing the electric arc, somewhat as in Fig. 2. In this case the current is derived from a direct current, shunt wound motor of 220 volts, coupled to a direct current, shunt wound dynamo of from 50 to 150 volts, and with this combination arcs up to 1,000 amperes are easily produced and handled by means of the rheostat. The tool to be tempered is fastened on the positive electrode, and the negative so arranged that the arc will heat the point of the tool without approaching the edge too closely. The current is then turned on and by means of the rheostat gradually increased until the proper heat is obtained, care being exercised not to raise it enough to burn or fuse the tool.

The hardening of milling or gear cutters, drills, screw-dies, taps, etc., is a different proposition and should be done in an oven or muffle-furnace. For this purpose a special design is used, consisting of two chambers, one above the other, both lined with fire brick, and the lower heated by a series of Bunsen burners beneath it. Control of these burners should be had so that the temperature in the lower chamber may be maintained at about 2,200 deg. F., while, of course, the upper chamber is at a much lower heat. After thoroughly warming the tool to be hardened, on the top of the furnace, it is placed in the upper chamber, and heated to about 1,500 deg. F., then placed in the lower one and allowed to reach the temperature of the chamber, or about 2,200 deg. F., at which time the cutting edges present a greasy appearance, and are a bright yellow color. They should then be removed and cooled in an air blast until they may be handled, then plunged into a bath of melted tallow at about 200 deg. F., and the heat of the bath then raised to about 500 deg. F. At this point the tool should be taken out and plunged in cold oil.

A knowledge of these points, therefore, should be sought after by those using these steels, and a better understanding of them will enable an operator to work more advantageously and economically.

When Does it Pay to Install a Complete New Machine?

In a Paper on "Economical Features of Motor Applications," Read before the American Society of Mechanical Engineers, Charles Robbins deals with the Conditions when Equipping Old Machines with Motor Drive.

When changing over from lineshaft drive to individual motor drive the question arises whether to equip the old lineshaft-driven machines with motors or to install new motor-driven machine tools. The old machines are not as strong in construction as new tools designed for motor drive, nor are they equipped with the latest devices by means of which the time required to make adjustments can be greatly reduced. Owing to weaker construction old machines cannot be made to remove metal as rapidly as machines built with this point in view.

The case taken for consideration involves the modification or exchange of a 72-in. vertical belt-driven boring mill, so as to obtain a greater output at lower cost per unit of product. This mill, the original cost of which was \$3,200, has been in use five years. The hourly overhead operating charge has been determined at 91 cents. The machinist receives 35 cents an hour for 54 hours per week (2,808 hr. per year). The total earnings for the year from this machine amount to \$4,200. The operating expenses for the year are as follows:—

Overhead $0.91 \times 2,808 =$ \$2,555.28
Wages $0.35 \times 2,808 =$ 982.80

Total \$3,538.08
Net profit $\$4,200 - \$3,538 =$ \$662.00

The depreciated value of this tool on a basis of 10 per cent. reduced balance is 66 per cent. of its first cost. If a motor is installed the investment appears as follows:

Value of tool $\$0.66 \times 3,200 =$ \$2,112.00
Cost of motor, gears, controller, wiring, etc. = 550.00

Total investment \$2,662.00

The hourly overhead charge of 91 cents includes interest and depreciation at 16 cents an hour; the overhead charge exclusive of interest and depreciation will therefore be 75 cents an hour. The depreciation on the new investment for the remaining five years' life of the tool will be 20 per cent. per year, making the charge for interest and depreciation 26 per cent. The operating cost of the old tool with motor drive is therefore:

Overhead (exclusive of interest and depreciation) $\$0.75 \times 2,808 =$ \$2,106.00

Interest and depreciation, 26 per cent of \$2,662 = 692.12
Wages, $\$0.35 \times 2,808$ 982.12

Assuming 10 per cent. increased earnings, due to adoption of individual motor drives, makes the total earnings:

$\$4,200 + \$420 =$ \$4,620.00

The net profit is then
 $\$4,620 - \$3,780.92 =$ 839.08
or 31.5 per cent. interest on the investment of \$2,662.

The corresponding figures based on the installation of a new machine tool with individual motor drive are approximately as follows.—

Cost of new tool = \$3,400.00
Cost of motor, etc. = 270.00
\$3,670.00

new tool. It is evident, therefore, that although a somewhat greater capital is required for the new installation, it is by far the better investment.

A MODERN MACHINE TOOL WAREHOUSE.

Staff Correspondence.

The A. R. Williams Machinery Co., Winnipeg, recently moved into their new premises on Logan Avenue, and at the present time are arranging the display of machine tools on the spacious main floor of the building. The structure is one of the finest warehouses in Canada, being 60 x 130 feet, and four stories high. It is of solid reinforced concrete and absolutely fire proof.

The feature of the interior design is the track facility for loading and unloading machines. Trucks may be



The Modern Machine Tool Warehouse of the A. R. Williams Co., Winnipeg.

Scrap value of old tool at 5% 160.00
Investment \$3,510.00
Overhead operating charge—
 $\$0.75 \times 2,808 =$ \$2,106.00
Wages as above 982.80
Interest and depreciation for 10 years (depreciation 10% interest 6%) $16\% \times 3,510 =$ 561.60
Total \$3,650.40

Assuming 25% increased output for the year, the total earnings become:
 $125\% \times \$4,200 =$ \$5,250.00
Net profit is then $\$5,250 - \$3,650.40 =$ 1,599.60
or 45.3% interest on the investment.

Conclusion.

The above figures show that for the conditions given, approximately 14 per cent. greater return on the investment is gained by installation of a complete

driven alongside the large electric elevator on which machines may be loaded and raised to any floor desired. Running from the elevator door on each floor is a heavy steel track made of a single bar of steel about 5" x 1". This track curves around from the elevator and runs the full length of the building making it possible to place machines conveniently at any desired location on the floor.

The first floor is utilized for steel drills and large front windows make a fine display of these from the outside. A small but well equipped office is also on the first floor, immediately at the right of the entrance, which is at the side as seen by the accompanying cut. The second floor displays the lathes and other heavy tools, and the third floor stores the bar iron, shafting and accessories. The fourth floor is leased to a stove firm.



IMITATION A SPUR TO EFFICIENCY.*

By Walter Dill Scott.

For the sake of clearness in studying acts of imitation we separate them into two classes—voluntary imitation (also called conscious imitation) and instinctive imitation (also known as suggestive imitation).

A peculiar signature may strike my fancy so that I unconsciously and deliberately may try to imitate it. This is a clear case of voluntary imitation. In writing letters or advertisements or magazine articles, I analyze the work of other men and consciously imitate what seems best. Or I observe a fellow laborer working faster than I and forthwith try to catch and hold his pace.

For precisely similar reasons, a "loafer" or careless or inefficient workman will lower the efficiency or slow up the production of the men about him, no matter how earnest or industrious their natural habits. Night work by clerks, also, is taken by some office managers to indicate a slump in industry during the day. To correct this the individual drags on the organization are discovered and either revitalized or discharged.

I have seen more than one machine shop where production could have been materially raised by the simple expedient of weeding out the workmen who were satisfied with a mere living wage earned by piece work, thereby setting a dilatory example to the rest; and replacing them with fresh men am-

* This article is abstracted from "Psychology of Business," a series of articles in "System," contributed by Walter Dill Scott, Director of the Psychology Laboratory of Northwestern University. This article deals with human efficiency and is based on the experience of executives whose instincts and intuitions are very keen, and give them the understanding of employes' motives and capacities, and suggest methods by which their full powers may be stimulated and used. The article is an important one on the science and art of managing men. For the employe, it blazes the trail to a plane of wider usefulness and greater material rewards. For the employer, superintendent and manager, it points the way to the knowledge and understanding which evokes organization, efficiency and individual power.—Editor.

bitious to earn all they could, who would have been imitated by the others.

In these instances it is assumed that the imitation is not voluntary but that we unconsciously imitate whatever actions happen to catch our attention. For the negative action, the "slowing down" process, we have the greater affinity simply because labor or exertion is natur-

BUSINESS MANAGEMENT.

In this department articles on costs and saving of waste will appear. The *leaks* and *losses* in your factory and my office, are right at *our* elbows, pulling at our cash drawers, threatening our business today. We must be interested, *vitaly*, in possible *economics* that will *stop* our *losses*, increase our *profits* and *strengthen* our business.

These articles are to arouse you to inspect your business *now*—to get you interested in *stopping* them—to arouse *thought*, then *interest*, then *action*.

In the June issue will appear in this department an article showing a successful, practical cost system in a manufacturing concern. If Canadian manufacturers are to compete in the world's markets they must *know* their costs and *eliminate* waste. *Knowing* the cost will stir your *interest* in looking for waste and the *elimination* of waste will *reduce* your cost.

Let *Economy* be a watchword and remember: *Doing* is the only thing that gets results.

ally distasteful. One such influence or example, therefore, may sway us more than a dozen positive impulses towards industry.

To profit from the instinctive imitation of my men, I must control their environment in

shop or office and make sure that examples of energy and efficiency are numerous enough to catch their attention and establish, as it were, an atmosphere of industry in the place.

Conditions may limit or forbid the use of pacemakers. In construction work and in some of the industries where there are minute sub-division of operations and continuity of processes this method of increasing efficiency is very commonly applied. In many factories, however, such an effort to "speed up" production might stir resentment even among the piece workers and have an effect exactly opposite to that desired. The alternative, of course, is for the employer to secure unconscious pacemakers by providing incentives for the naturally ambitious men in the way of a premium or bonus system or other reward for unusual efficiency.

To take advantage of their conscious or voluntary imitation, workpeople must be provided with examples which appeal to them as admirable and inspire the wish to emulate them. The oldest, simplest application of this principle is seen in the choice of department heads, foremen and other bosses. Invariably they win promotion by industry, skill and efficiency greater than that displayed by their fellows, or by all-round mastery of their trades which enable them to show their less efficient mates how any and all operations should be conducted.

Judged by the results of the investigation the most common use of imitation is in the train-or "breaking-in" of new employes. The accepted plan is to pick out the most expert and intelligent workman available and put the new man in his charge.

By observing the veteran and imitating his actions, working gradually from the simpler operations to the more complex, the beginner is able to master technique and methods in the shortest possible time. The psychological moment for such instruction, of course, is the first day or the first week. New men learn much more readily than those who have become habituated to certain methods or tasks; not having had time or opportunity to experiment and learn wrong

methods, they have nothing to unlearn in acquiring the right. They fall into line at once and adopt the stride and the manner of work approved by the house.

This is the specific process by which the most advanced industrial organizations develop machine hands and initiate skilled mechanics into house methods and requirements. It has been largely used by public service corporations—street car motormen and conductors, for instance, learning their duties almost entirely by observation of experienced men either in formal schools or on cars in actual operation. Many large commercial houses give new employes regular courses in company methods before entrusting work to them; the instructor is some highly efficient specialist, who shows the beginner how to get output and quality with the least expenditure of time and energy. The same method has been adapted by leading manufacturers of machines, who call their mechanics or assemblers together at intervals and have the most expert among them show how they conduct operations in which they have attained special skill.

Educational trips to other factories were employed by several firms to stimulate mental alertness and the instinct of imitation in their men. These trips usually supplemented some sort of suggestion system for encouraging employes to submit to the management ideas for improving methods, machines or products.

Cash payments were made for each suggestion adopted, quarterly prizes of ten to fifty dollars were awarded for the most valuable suggestions; and finally a dozen or a score of the men submitting the best ideas were sent on a week's tour of observation of other industrial centres and notable plants. In some instances the expense incurred was considerable, but the companies considered the money well spent. Not only were the men making helpful suggestions the very ones who would observe most wisely and profit most extensively from such educational trips; they brought back to their everyday tasks a new perspective, saw them from a new angle, and frequently offered new suggestions which more than saved or earned the vacation cost.

Business managers, it was made plain, are coming more and more to depend upon imitation as one of the great forces in securing a maximum of efficiency without risking the rupture or rebellion which might follow if the same efficiency were sought by force or by any method of conscious compulsion. Tacitly suggested, the examples for imitation will

lead men where no amount of argument or reasonable compensation will drive them. I am, therefore, led to suggest the following uses of imitation for increasing the efficiency of the working force:

In breaking in new recruits they should be set to imitate expert workmen in all the details possible.

Gang foremen and superintendents should always be capable of "showing how" for the sake of the men under them.

The better workmen should, where possible, be located so they would be observed by the other employes.

Inefficient help should be avoided lest the examples of the less efficient should become the model for the larger group.

Educational trips or tours of inspection should be regularly encouraged for both workmen and superintendents.

\$10 For An Idea

For the "Business Management" department of Canadian Machinery.

We want ideas for this department—ideas of practical, labor-saving, cost-reducing value. We will pay at regular rates for each idea accepted, and in addition will pay \$10 for the best idea submitted during the next five months—that is, until Sept. 30, 1910.

Address all communications to the Editor of Canadian Machinery, 10 Front Street East, Toronto, Ont.

The deeds of successful houses should be brought to the attention of employes.

Where conditions admit, pacemakers should be retained in various groups to key up the other men.

Favorable conditions should be provided for conscious and instinctive imitation for all the members of the plant.

INCREASING THE EFFICIENCY.

The Simonds Mfg. Co., Fitchburg, Chicago and Montreal, believe that efficiency in their plants is greatly increased by co-operation with their men. Carrying out the Simonds policy in connection with their new saw factory at Lockport, they will build at once fifty houses for the company's employes, on the best lines that can be found for dwellings of the type desired, and the settlements will be brought up-to-date in point of perfectness of equipment and completeness and every provision made for the health and pleasure of their employe-tenants.

At the Fitchburg plant the company maintains a club room, recreation room,

baths, gymnasium and medical service for its many hundred employes. The company has also established a complete pension system for its employes in its several plants, office force and operatives.

Speaking of all these matters in a more intimate and personal way, a representative of the Simonds Mfg. Co. said:

"Progress along manufacturing lines is to-day based on quality and service. As good as our service was, it was proving inadequate. To win, therefore, that fullest measure of success which we believe we merited demands attention equally to the goods we manufacture, the conditions under which they are produced and the way we treat our customers. The public demand to-day is for the very best of anything that can be produced. The best, it is needless to say, can be made only under proper, i.e., the best conditions. Part of these conditions means affording workmen the greatest advantages in return for increasingly faithful service. It means regulating the physical or purely mechanical features of the establishment in a way that will promote the greatest harmony."

STOCK WISE—LABOR FOOLISH.

By James F. Hobart.

A workman who should know better, and a foreman who is paid for looking after things in general are sometimes guilty of time waste, which is ridiculous when one comes to consider the matter. For instance in the shipping department of a machine shop, I recently saw the head of that department trimming up a stencil, with a scissors, which the machine had not cut clean owing to the extreme thinness of the paper. Ordinary thin wrapping paper had been used instead of the strong thick paper provided for the purpose of stencil-cutting.

Upon being asked why he spent so much time on that work, instead of using the regular paper, the workman replied, that he only wanted a very small stencil and used the wrapping paper to save the regular paper. As the man was working 60 hours a week for \$16.50, or 458-1000 cent per minute, two minutes were spent trimming the stencil, at a cost of 916-1000 of a cent. The paper 4 inches wide and 10 inches long weighed 3-16 ounce and at 10 cents a pound cost about 1-10 a cent as nearly as you can figure it. Trying to economize in that way will never prove profitable.

Another instance occurred in a large eastern railroad. The master mechanic wanted a lot of new ratchet drills at a cost of \$3.48 apiece, that being the price for which he could purchase 100 new ones. The directors would not listen to the request, but ordered the

master mechanic to rebuild the old ratchets in the shop. This was done, and the cost totaled about \$9.80 apiece for the 100 odd rebuilt ratchets.

Instances of this kind can be multiplied indefinitely. They indicate that someone connected with the mechanical industry should make it his business to watch each operation performed by each and every man, from general manager down to water boy, and determine if there is not some other way of making those moves which will save one-half the time, or cost a little less for energy expended in moving. Truly, this is the day of small economies; they must be looked after closely or many little losses will creep in.—American Machinist.

STOPPING SHIPPING LEAKS AND SHORTAGES.

Sealed boxes prevent shipment shortages in one factory, says a writer in "Factory." At first sight they appear too frail to stand the wear and tear of the heavier boxes, as the boards are much thinner. However to offset this, the boxes are provided with four or five strong wires with staples securely driven and firmly clinched by machinery. The ends of these wires project at the same edge so that when the box has been packed they are then sealed with a leaden seal.

The box can then only be broken into by breaking the seals or the wires. A glance will then detect this if the box has been tampered with and in this way there is a complete check on the contents while en route.

One company began their use by trying out a sample lot. When the boxes were first used a letter was sent to trace the condition of the box at its destination and it was found that the consignee was pleased with the box. The box weighs about one-half to one-third that of the unwired box and in case of a long haul when it is considered that the average per cent. of the weight of packing cases is with much merchandise shipped to the merchants about 25 p.c. A wire-bound box shipment was a case for Louisville, Ky. The box and contents weighed 165 pounds and the box weighed only 21 pounds or a little less than 13 per cent.

CUTTING DRAYAGE EXPENSE.

By Rube Borough.

During the first years in which I was employed in a carriage factory I was at times a sort of "emergency man." I trimmed shafts, and, whenever the supply of finished shafts piled up in excess of the demand, I was transferred

to other departments of the factory work. I wiped out odds and ends of jobs in the "paint shop," in the "blacksmith shop," and I helped out in the crating room.

The company by which I was employed owned its horse and dray and did its own draying. The man who had charge of this work handed in his time at the end of the week to the foreman of the crating room. When not busy with the dray, he helped to crate the finished work.

One week during the summer, while this man was away from the factory, I was given his job. My duty, as I sized it up, was to be two-fold: I was to deliver the crated buggies at the freight depot and was to bring back from the freight depot to the factory the small "sorting up," summer shipments of tires, wheels, seats, bodies, and so on.

My first day on the job was planless. I blundered ahead, drawing to the freight depot in the morning a dozen crated buggies and wasting time at the freight depot doors which were almost constantly besieged during the rush morning hours by dozens of the town's draymen. Also I was delayed several times at side-track crossings.

Late in the morning an incoming train unloaded the first freight of the day, leaving for the buggy company, a half dozen dray loads of seats, bodies, tires, wheels, etc. In the afternoon I drew this stuff to the factory. I was not delayed—the railroad side-tracks were clear and there were not many draymen at the freight depot doors.

That first day—toward the end of the afternoon—I worked, for not quite two hours, in the crating room.

Now, for results of the first day's work:

First, I must cut in two the number of trips with the dray to the freight depot. I must never have an empty dray behind that horse—it must be loaded with outgoing freight, always, on the way over to the freight depot, and loaded with incoming freight, always, on the way back to the factory.

Second, I must visit the freight depot at a time of the day when switching freight trains and that odd dozen of other draymen should be out of my way.

The second day and the rest of the week, I carried through to a successful finish a program of work as follows: In the morning, work in the crating room. In the afternoon, work with the dray.

By this plan I had three hours more work in the crating room.—Factory,

TIME LIMIT SYSTEM SATISFACTORY.

By W. R. Smith.

I thoroughly believe that the time limit is the correct idea. It is the proper system, but it is governed entirely by conditions. A department cannot give proper results on a time limit unless other departments produce the required efficiency. Before stating a standard time for doing a certain amount of work, you have to check previous records as to what can be accomplished and to find the time required to do that work according to other existing conditions.

The foremen who are in charge of the men in the different departments look over the time slips each morning before being sent to the General Foreman's Office, where they are checked over, and if it is found that a certain piece of work, we will say for instance putting on a cylinder, taking down a frame, setting guides, piston and crosshead work, or whatever the case may be, has cost more than usual or does not compare with previous records, it is immediately investigated as to the reason, so that we are thoroughly convinced that our time records are correct before our time slips go to the time office or audit department.

INCREASING EFFICIENCY OF MEN

By M. E. D.

It is being recognized almost everywhere to-day that the education of the men is necessary to increase the efficiency of the shops. The railroads in both United States and Canada have been leaders and set an example which might well be followed by Canadian manufacturing concerns. Examples of apprenticeship systems on the C.P.R. and G.T.R. have been given in Canadian Machinery. The following is another example of railroad progressiveness and goes to show the value placed by railroads on education of the men.

To increase the efficiency of the men operating its trains, the Pennsylvania Railroad has determined to adopt the use of signal instruction cars on all of its divisions. The divisions on the main line between Philadelphia and Pittsburg have just been equipped.

The company realizes that safety of operation depends upon its employes having a thorough knowledge of all signals, and it has been decided that explicit personal instructions shall be given frequently to enginemen, firemen, conductors and trainmen. The instructions to be given in this signal car will include not only block and interlocking signals, but all other signals used in the movement of trains,

Practical Ways of Obtaining Economy in the Factory

Co-operation Between Men and Foremen, and Managers has Resulted in Large Annual Saving at Canadian Works of National Cash Register Co.

THE superintendent of the Canadian branch of the National Cash Register Co. believes in getting in close personal touch with the work in the different departments. He works on the principle that the shop foremen ought to develop labor saving, cost reducing schemes. The foreman knows his department intimately and with a little incentive, takes pains to think out better ways of doing the work under his supervision.

The superintendent endeavors to develop the workmen and with this in view a rest and reading room has been fitted up where the men may spend a quiet quarter hour at the noon hour perusing such mechanical and educative papers as Canadian Machinery.

Boxes are placed at the stairway leading to the different floors and here the workmen are requested to deposit suggestions which will tend to increase efficiency and economy, increasing the

cussed and the suggestions of the men dealt with. Here by the result of planning schemes have been devised which have cut \$11,400 from the operating expenses of the factory without impairing in any way the quality of the output.

Saving of Waste.

In almost every factory there is an accumulation of various pieces of factory equipment, stray bolts, shafting hangers, belting, etc. At the National Cash Register Company's works, a room has been set apart for accumulative stock. If there is a pulley, bolt or any other piece of factory equipment not in use it is returned to this room where it is ticketed and listed. Now the purchasing agent buys nothing until the stock keeper is consulted.

Making the Men Punctual.

A simple check system is in use. A box is located in each department and the men drop their checks into the box

a well-ordered stockroom is here shown. It was customary to have one or two men familiar with all the parts and depend on them for the delivery of stock to the various departments. As there are 13,000 parts kept in stock, the stores department was crippled if one of the workmen was ill or away for a day. It also hindered prompt deliveries on account of men not familiar with the work, having to handle the supplies.

A saving of 50 per cent. of the cost of maintenance has been effected in this way: A card bearing the number of the part and its name, is fastened to the front of each pocket in the bins. Then each row of pockets, and each bin is numbered 1, 2, 3, 4, etc. The parts are all listed alphabetically in a book for the purpose similar to the following:

1071 screw for cash drawer 3.16 in. x $\frac{3}{4}$ in. bin 2, row 2.

It is therefore seen that an uninitiated workman can easily locate stock and there are therefore no delays in obtaining material.

Piece Work in Erecting Shop.

Satisfactory results have been obtained by introducing the piece work system in the erecting shop and it is intended to introduce it into some of the other departments. When a job is given to a workman a job card is issued and this card must be presented to the foreman to show that the job is completed before he can obtain a new one. In this way the men are prevented from holding back work and entering it on the piece work card for the following day.

Dumb-waiter.

A dumb-waiter has been installed, which carries the work from the stock room on the second floor to the machine shop on the third floor and to the assembling room on the top floor. The time of a man is thus saved, for those employed in the stock room can send the boxes of small parts to the departments mentioned.

Obtaining the Men's Enthusiasm.

Mention has been made of the rest room. In addition there is a coat and wash room with rows of lockers, where the men keep their coats, towels, etc. The lockers were made by the company at a cost of about 90cts each. Wire screening is used for the front of the lockers.

Two towels and two aprons are supplied each workman per week. Every week, each is allowed to take a bath in the company's time, sprinkler baths being kept up by the company. The men are thus encouraged to be neat. Each man and foreman is made as responsible as is possible for the work under his charge. It makes them more enthusiastic and useful and they obtain higher wages.



The Stock Room of National Cash Register Co., Toronto. A is the Card giving Name and Number of Part. B is card made in Quadruplicate, One Copy being Sent to Stock Department showing Quantity of Stock Ordered. When it Comes to Hand, it is Checked by Stock Men. C is Signal Bell. D Shows Small Boxes Used for the Easy Handling of Parts.

output or reducing the expenses. Perhaps some impractical ideas are submitted sometimes but by explaining to the men why they will not work, other practical ideas are suggested. At any rate, it keeps the men thinking and useful ideas are developed.

Banner Department.

To stimulate the practice of economy, and habits of cleanliness and punctuality, a banner containing the words "Banner Department" is hung in a prominent place in the department in which the best record is made. At the present time it is in possession of the Foundry Department.

Fortnightly Conference.

Another scheme that has resulted in the saving of thousands of dollars each year is the result of fortnightly conferences held in the reading room. Means of improving the plant are dis-

in their particular department. Bells in the different departments are controlled by the engineer. Automatically, as he rings the bells at seven and one o'clock, a simple electrical device closes the opening in the check box and the late comer must report to the foreman.

This means a saving as men are trained to be punctual. Supposing ten men in the factory, earning \$2.00 per day, were five minutes late each working day, it would mean a loss to the company of \$50 per year. If there were 20 men it would mean \$100 per year; if the 20 men lost 10 minutes, the loss would be \$200; if the men received \$3 a day, it would be \$267. Therefore in teaching the men to be prompt, savings have been effected in this way.

Indexing the Stock.

In order that the reader may appreciate the saving that may be made by

CANADIAN MACHINERY

AND MANUFACTURING NEWS

A monthly newspaper devoted to machinery and manufacturing interests mechanical and electrical trades, the foundry, technical progress, construction and improvement, and to all users of power developed from steam, gas, electricity, compressed air and water in Canada.

The MacLean Publishing Co., Limited

JOHN BAYNE MACLEAN, President W. L. EDMONDS, Vice-President

H. V. TYRRELL, Toronto Business Manager
G. C. KEITH, M.E., B.Sc., Toronto Managing Editor
F. C. D. WILKES, B.Sc., Montreal Associate Editor

OFFICES:

CANADA

MONTREAL Rooms 701-702 Eastern
Townships Bank Bldg
TORONTO - 10 Front Street East
Phone Main 7324
WINNIPEG, 511 Union Bank Building
Phone 3726
F. R. Munro
BRITISH COLUMBIA - Vancouver
H. Hodgson,
Room 21, Hartney Chambers

GREAT BRITAIN

LONDON - 88 Fleet Street, E.C.
Phone Central 12360
J. Meredith McKim

UNITED STATES

NEW YORK - R. B. Huestis
1109-1111 Lawyers' Title, Insurance
and Trust Building
Phone, 1111 Cortlandt

FRANCE

PARIS John F. Jones & Co.,
31bis, Faubourg Montmartre,
Paris, France

SWITZERLAND

ZURICH - Louis Wol
Orell Fussli & Co

Cable Address:

Macpubco, Toronto. Atabek, London, Eng.

SUBSCRIPTION RATE.

Canada, United States, \$1.00, Great Britain, Australia and other colonies 4s. 6d., per year; other countries, \$1.50. Advertising rates on request.

Subscribers who are not receiving their paper regularly will confer a favor on us by letting us know. We should be notified at once of any change in address, giving both old and new.

Vol. VI.

May, 1910

No. 5

CANADA'S GROWING TRADE.

Canada's total trade for the fiscal year ending last month reached the record figure of \$677,142,189. This is an increase of no less than \$117,506,238, or over twenty per cent., as compared with the preceding twelve months. It is an increase of over twenty-six millions as compared with the previous high record of 1907-8. At present the regular monthly increases over the corresponding months of last year are running over ten millions per month, and indications point to a total trade in the neighborhood of eight hundred millions for the current fiscal year.

The total imports for the year were \$375,783,660, an increase of \$77,659,868 over 1908-9. Exports of domestic products totalled \$279,211,537, an increase of \$36,607,951.

Exports of foreign products totalled \$22,146,992, an increase of \$3,238,419. The chief items of export for the year, with comparative figures are as follows:—

	1908-9.	1909-10.
Agriculture	\$71,997,207	\$90,433,747
Forest	39,667,387	47,517,033
Animals and their produce.	51,349,646	53,926,515
Mines	37,257,699	40,087,017
Manufacturers	28,957,050	31,494,916
Fisheries	13,319,664	15,627,148

The total duty collected for the year amounted to \$61,010,489, an increase of \$12,269,475.

The total trade for March last was \$66,564,208, an increase of \$13,250,000. Imports for the month totalled \$43,391,991, an increase of about \$10,500,000. Exports of domestic products totalled \$22,199,275, as compared with \$18,397,974 in March of last year.

CO-OPERATIVE TECHNICAL EDUCATION.

In this issue of Canadian Machinery we publish a paper written by Robert Patterson, in which he advocates technical education for apprentices. He suggests that it be made possible for an apprentice, on completion of his term of practical training, to attend the university for a year, and combine theory and practice.

It is a poor rule that does not work both ways, and if the combination of theory and practice is good for an apprentice, it is also good for a student at the university. At some of our Canadian universities there are mechanical laboratories, where the students learn to run a lathe, use a drill, planer, etc., but it is the seven o'clock whistle, and the clink of the time check that makes a student know what his education is worth.

A young man in attendance at one of our universities spent his summers in one of the large locomotive shops. At the close of his second summer he went into the office to bid the master mechanic good-bye. It was a thoughtful time for him, and he thus addressed the head of the shops:

"I have spent two summers in the shops and any of the apprentices can take hold of a job and do it better than I can. Next spring I hope to get my degree; what am I then fitted for?"

That master mechanic had a great respect for that young man on account of his coming to the point of understanding. He realized, as all should, that when a man receives a salary or wages, the company makes an investment to the amount of the salary and wages, and the man must be in a position to give returns for that investment, which will justify the expenditure.

The student was recommended to spend another year or two in the shop and then, with both the theoretical and the practical knowledge combined, he would be prepared to take a more responsible position than he otherwise would.

Frederick W. Taylor, who presented that notable paper before the American Society of Mechanical Engineers, a short time ago, on "The Art of Cutting Metals," has taken an active interest in technical education, and he says:

"At college a very large amount of time is given up to the study of materials. Practically his whole chemical course is the study of materials. A very considerable part of his course in physics has to do with materials. The greater part of his work in a mechanical laboratory is a study of materials. Do you realize that the great raw material with which more than one-half of the successful graduates of our technical schools have to deal, receives not a single hour of study at our colleges and universities, not one hour? That the great raw material with which the managers, superintendents, presidents, every man of our large companies is dealing, is men? And these one-half of the students, who are finally called upon to manage workmen, learn nothing whatever about that at college. At twenty-two years of age on the average they land outside of college without the slightest knowledge of the great raw material with which more than one-half of them will have to work throughout their lives."

A joint committee appointed by seven of the English engineering societies, with three of the professors from universities, unanimously voted that it was desirable to

have two years' apprenticeship before students graduated as engineers. This is a very remarkable recommendation. It would, however, give the student a chance to understand shop conditions, and will show him that each one in an organization must become one in a train of gears. The combination of practical and theoretical will ensure success.

RAILROADS AS A TRADE BAROMETER.

For years the buying of the railroads has been looked upon as a trade barometer. At the present time large orders for freight equipment are being placed by the railroad corporations. Recently the C.P.R. placed an order for 1,000 steel freight cars, and within the past two weeks a second million-dollar order for 1,000 cars, all of which will be ready for the 1910 harvest. In addition to these orders, which have been placed with an outside company, and which are being turned out at the rate of fifteen cars per day, the C.P.R. are building twenty-four cars per day, making a total output of nearly forty cars per day.

The G.T.R. is calling for tenders for well over \$3,000,000 of freight equipment, much of which is being ordered in anticipation of the wheat business from the west next year. The prospective order includes two thousand five hundred steel-frame box cars of 100,000 pounds capacity, especially designed for wheat carrying, and of a type which is a radical departure for the road. Twenty of these cars in a train will carry a thousand tons of wheat, and they will be utilized next fall when the western harvest starts.

In addition, the G.T.R. is now advertising for tenders for 500 special automobile cars. These are steel-framed box-cars, with doors taking up almost their whole end, so that big touring cars can easily be run in or out. The Grand Trunk touches Detroit and other big auto manufacturing cities, and has found special equipment necessary for this trade.

It is preparations like this that convey confidence to those who want more than general opinion before they are satisfied as to a country's prospects. When men who have their pulse so truly on the situation, like those constituting the management of our great railroads, start such equipment provision there can be little room for doubt.

AIMS TO CURB COMBINES.

Hon. Mackenzie King, Minister of Labor, has introduced a bill in the Dominion Parliament, which aims to provide machinery for investigating charges that prices of commodities have been unduly enhanced by combines.

The bill, in brief, provides that where six or more persons are of opinion that a combine exists, and that prices have been enhanced or competition restricted by reason of such combines, to the detriment of consumers, they may make an application in writing to a High Court judge for an order directing an investigation into such alleged combine. If upon such hearing the judge is satisfied that there is reasonable ground for believing that a combine exists which is injurious to trade, or which has operated to the detriment of consumers, and that it is in the public interest that an investigation should be held, the judge shall direct an investigation. The Minister of Labor then chooses a board of three members to investigate the alleged combine, which if found guilty, is liable to a fine of \$1,000 a day and costs for each day it offends after the expiration of ten days from the date of the publication of the board's report in the Canada Gazette.

The bill has been introduced late in the session and as it is an important measure, it is likely to be held over until next parliament before final adoption. Mr. King will have the sympathy of a large body of Canadian citizens in his endeavor to restrict the harmful influences of trusts and combines, while leaving trade associations free to continue their regulation of the minor details affecting their various industries.

The chief defect of the bill proposed seems to be the ease with which a handful of individuals could cause business enterprises a lot of trouble by compelling them to present books and other documents in court to disprove charges which may or may not have been laid by responsible persons. A discussion of the features of the bill is desirable and wise action would be taken in referring it to a committee of the House or allowing it to stand over until the next session of Parliament.

IRON MILLS TO MERGE.

The latest rumor in connection with the proposed merger of various iron and steel mills is that the Dominion Iron and Steel Co. are interested in the offer to purchase the Montreal Rolling Mills. This is incorrect, however.

The Dominion Iron and Steel Co. were mentioned in this connection some time ago but more recently the understanding has been that the merger would include the Hamilton Steel and Iron Co., the Canada Screw Co., the Canada Bolt and Nut Co. (with mills at Brantford, Toronto, Belleville and Gananoque), and the Montreal Rolling Mills. There has been trouble in securing the approval of the Hamilton Steel and Iron Co.'s shareholders, however, they holding out for \$9,000,000 in stock in the new company, whereas they have only been offered \$7,500,000 in merger stock for their \$3,000,000 of Hamilton Steel and Iron stock. This seems to have upset arrangements as it is now said that the merger will be gone on with without any steel company being included, it being purely an iron mill consolidation.

That the proposition is progressing is evident from the fact that the directors of the Montreal Rolling Mills issued on Thursday of this week a circular to shareholders advising them to accept the private offer made of \$300 per share for stock which has been quoted at \$250. Replies are requested by June.

A considerable step forward was made when the Canada Bolt and Nut Co. consolidated half a dozen mills under one head, and if the Hamilton and Montreal mills join interests with the Canada Company, having headquarters in Toronto, the finished iron products industry will be in a strong position and capable of competing successfully with the large United States corporations.

If no steel mill is included in the iron merger, it is probable that the merger of Canadian steel industries, suggested some months ago, will be gone on with and the leading Canadian iron and steel industries consolidated under two heads working in alliance with each other.

ELIMINATION OF WASTE.

A question that is receiving the attention of manufacturers at the present time, probably more than ever before, is the saving of waste. In factories similar conditions exist as in locomotive repair shops, and in both these, as Mr. Smith points out in the article "Making an Annual Saving of Thousands of Dollars," great savings can often be made by eliminating the expensive handling of material. In the case in point, \$8,000 was saved annually by the installation of a crane. The store room is often the source of a great deal of waste which may be

greatly reduced by storing material in bins, protecting it from atmospheric conditions, etc.

In this connection also a great responsibility rests on the purchasing agent. This is also pointed out by Mr. Smith. Proper materials should be on hand when required and purchased when they are cheapest. The using of more expensive material than is required, because it is on hand and the specified material is not in the store department, is a source of waste which should be avoided.

A buyer for a manufacturing works often tries to have as little stock on hand as he possibly can. It costs money to carry stock, he says, and money brings in a large interest. It must also be remembered, however, that it costs money to wait for stock; it costs many times what the stock is worth to wait for it. In many cases it will be found that it pays to carry a large stock, especially of standard articles.

One way in which a saving can be made is to get the full efficiency from the machines at all times. The introduction of high speed steel has assisted us in doing this to a certain extent. The design of machine tools has had to advance to keep pace with the use of high speed steel and a great economy has been effected in largely increased production.

Another thing that works for economy is to have a well-balanced shop, that is, that production in the various departments must be balanced in such a manner, that the erecting shop has always a supply of material. This applies to all classes of factories. In the locomotive shop, the boiler, foundry and machine shops must work together to get the highest efficiency out of the shops. If the erecting shop cannot get cylinders from the foundries, or if they cannot get work from the machine shop, the department at fault should be strengthened to bring it up to the producing strength of the other shops.

The railroad shops of to-day are among the most progressive in securing economies and the manufacturers, generally, who look after the small items are placed in a better position to compete in the world's markets.

One reason for this is that the railroad official is ever ready to investigate anything which will result in further economies in the shops. A railroad repair shop is, as a rule, a model of economy. The machinery equipment is suited to the purpose for which it is intended and by the systems in use, stock is carefully accounted for, tools are taken care of and departments are in close touch with the master mechanic.

In the twentieth century development, however, new schemes are being devised which make it necessary for every manufacturer, master mechanic, superintendent and foreman to be on the alert. The reason for the growth and success of many industries is that the waste is taken care of and economies are introduced which has enabled them to make considerable profits. Some hard study is necessary to reduce the costs of manufacturing but the achievements of those who are eliminating waste, show that it is worth the investigation and work connected with it.

SECRET COMMISSIONS ACT.

His Lordship, Justice Magee says it is illegal for a purchaser to accept a secret rebate. The Secret Commissions Act makes no distinction between receiving and giving a secret commission.

Justice Magee says: "If you sent your servant to market to buy a horse and there he meets with a man who offers him a horse at \$150 and says, 'If you will buy this horse at \$150 I will give you \$10 of it to yourself; and you need not have any compunction about it, because I would not let your master have it for less than \$150.' And your servant gets it for \$150 and puts

the \$10 in his pocket, you can recover that \$10 from your servant. It is your money, not his, because it was made out of the transaction which he was carrying on with some person else for you; now, that is clear law. So, a commercial traveler sent out by a house here in Canada to buy goods for that house in the States, and he may be offered a commission by a person in respect to the goods he buys. When he comes back to Canada, if the transaction ever becomes known, he is liable to pay over that money to his employers. He has no right to be paid at both ends, unless it is known. This question of double commissions has for a long time past been quite too common, and has been permeating to a large extent the commercial life of the country. So much is that the case that last year the Dominion Government passed an act making it a criminal offence to take a double commission."

Let us see whether the other half of the act is not just as binding on the giver of the secret rebate as it is on the receiver. Clause (b) reads as follows: "Being an agent, corruptly gives or agrees to give or offers any gift or consideration to any agent as an inducement or reward or consideration to such agent for doing or forbearing to do, or for having after the passing of this Act done or forborne to do, any act relating to his principal's affairs or business, or for showing or forbearing to show favor or disfavor to any person with relation to his principal's affairs or business."

It must be evident from the above that the object of the law is to prevent the seller from giving a secret rebate or other consideration is clearly violating the act.

So far as the liability of the person who accepts the secret rebate is concerned, clause (d) covers that. It reads: "Every person who is a party or knowingly privy to any offence under this act shall be guilty of such offence and shall be liable upon conviction to punishment hereinbefore provided for by this section."

So that an engineer or any other person who accepts a secret commission or consideration is guilty under the provisions of the act and liable to the penalties it imposes.

Canadian Machinery is pleased to know that its position has been so fully endorsed by such an eminent authority as Justice Magee. We are especially pleased because it tends toward honesty in business and it should, therefore, be hailed with pleasure by every honest person in Canada.

TO HELP CANADIAN ZINC INDUSTRY.

A bill introduced by Hon. Wm. Templeman is now before the House of Commons at Ottawa authorizing the expenditure of \$50,000 for investigating processes used in the production of zinc and for making experiments for the promotion of the production and manufacture in Canada of zinc and zinc products from Canadian ores.

The bill has already been read a second time and been considered in committee, and it will likely be passed.

Some \$2,500,000 was voted several years ago for a bounty on lead production, and of this \$1,000,000 remains in the treasury. The present bill proposes to expend \$50,000 of this balance on zinc experiments.

There are no zinc smelters, in Canada at present. One was started at Frank, Alta., some years ago, but the proposition was not a success. Lead and zinc are closely allied in the ores of British Columbia and to save the zinc, which at present goes to waste, the Government has consented to conduct experiments in Canada, the United States and in Europe.

MACHINE SHOP METHODS ^A_N^D DEVICES

Unique Ways of Doing Things in the Machine Shop. Readers' Opinions Concerning Shop Practice. Data for Machinists. Contributions paid for.

TURNING SEMI-CIRCULAR GROOVES.

By J. H. R., Hamilton.

The accompanying cut shows a device for turning semi-circular grooves in small wheels as shown.

The device is practically a compound-rest with the addition of a worm and worm wheel for revolving the tool.

The piece P is bolted to the compound rest R by the bolt B, the tongue t fitting the slot in the rest R.

The worm wheel is secured to the extension on piece A which passes through piece P and held in position by the washer W and cap screw C.

On the side of the piece P are two

brass parts. As they come from the foundry they are sorted into bins; as the stock is required the pieces are taken to the machine shop. Here they are handled again by the driller, the

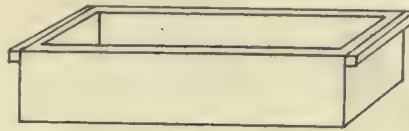

Box for Handling Duplicate Parts.

lathe hand or the assembling man or all three.

For the handling of small parts economically, the accompanying sketch shows one that has met with the ap-

proval of a number of factory managers. The size can be varied, but it is not advisable to make them too large. As a driller completes the operation on a piece, he can drop them into a second box. Then they can be passed along to the assembling room without the labor of picking them up off the floor before and after each machining operation.

Weight of Sheet Zinc.

Zinc Gauge.	B.W.G.	Weight per Square Foot in lbs.	Weight in lbs. of a Sheet 7 x 3.	Weight in lbs. of a Sheet 8 x 3.
No. 6	30	0.418	8.778	10.032
No. 7	29	0.484	10.164	11.616
No. 8	28	0.555	11.655	13.320
No. 9	27	0.644	13.524	15.456
No. 10	25	0.714	14.994	17.136
No. 11	24	0.832	17.472	19.968
No. 12	23	0.945	19.845	22.680
No. 13	22	1.063	22.320	25.512
No. 14	21	1.172	23.612	28.128
No. 15	20	1.360	28.560	32.640
No. 16	19	1.546	32.466	37.104
No. 17	18	1.730	36.330	41.520

FACTORY OR FOUNDRY SKYLIGHT

The skylight shown in the accompanying sketches has been designed to meet the demand for a cheap but absolutely strong and weather tight light and can be made advantageously in sizes up to 3x3 feet. It is of simple construction, and can be made complete in three hours by a competent mechanic. If it is necessary to use these lights in various sizes, sheet metal stub patterns should be made as shown in the drawings. The length of the bars is computed by the usual methods, except that as they do not come down on the glass rest of the curb; the common bars are cut 1/2-in., and the hip bars 1/4-in. less than measurements.

The vent neck is made in one piece, as shown in the isometric drawing. In bending this sheet it should be creased along the lines G H before being form-

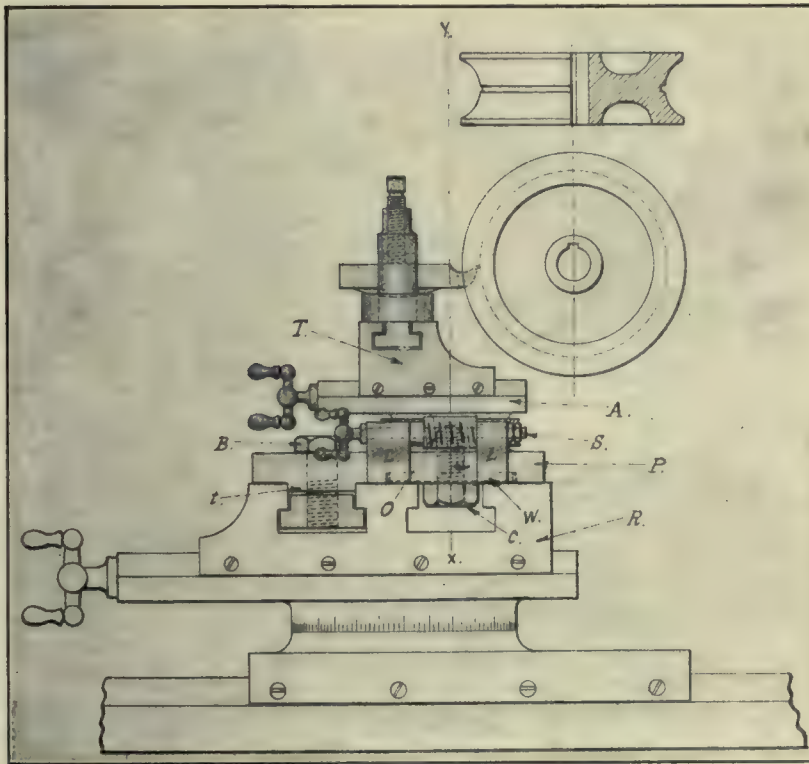

Turning Semi-Circular Grooves.

lugs L L, which carry the shaft S on which is secured the worm O. The top slide T is for setting the tool when the centre of motion x y is in the desired position.

HANDLING SMALL PARTS ECONOMICALLY.

By K. Campbell.

In a great number of shops, such as in agricultural works, there are a great number of small parts to be handled. There are malleable, grey iron and

proval of a number of factory managers. The size can be varied, but it is not advisable to make them too large. As a driller completes the operation on a piece, he can drop them into a second box. Then they can be passed along to the assembling room without the labor of picking them up off the floor before and after each machining operation.

WEIGHT OF SHEET ZINC.

By J. Staveley.

The accompanying table gives some useful information on the weights of

NOTICE TO SUBSCRIBERS

Subscribers will confer a favor on us by notifying us in case they are not receiving their paper regularly, or if they find they have missed one or more issues. We send out thousands of copies each month, and it is only natural to suppose that a few copies will go astray in the mails, even though every precaution is taken by us to avoid this.

We should also be notified at once of any change of address, giving both old and new addresses.

ed into the required shape. The corners should then be cut out at M, M, M, and the sides of the neck pulled around until

to the vent at T set them on the curb and tack at R. Next put in the hip bars and tack at R and S. The sky-

But if an odd thread is to be cut which the modern lathe will not handle (or in a small jobbing shop), it must be cut in the engine lathe with the individual change gears.

The object of this article is to make clear the method of determining the different trains of gears necessary to cut the various threads. Fig. 1 shows a simple train of gears, while Fig. 2 shows a compound train. When cutting a certain number of threads per inch the ratio of speeds between the work and the lead screw must be determined.

If a lathe lead screw has a pitch of 1-6-inch, or six threads to the inch, and it is required to cut a thread of the same pitch, it is clear that the ratio will be 6:6 or 1:1; that is, the lead screw must make one revolution while the work is making one revolution.

But if the thread to be cut is 1-8-inch pitch, or 8 threads to the inch, the lead screw must only make six revolutions while the work makes eight revolutions.

Always remember that the number of revolutions of the work multiplied by the number of teeth in the driving gear must equal the revolutions of the lead screw multiplied by the number of teeth in the driven gear.

This applies also to the compound train. To find the gears necessary to cut the above by simple train.

Threads per inch on the work=8,
Threads per inch on lead screw=6.

If we have gears with 6 and 8 teeth we have to put the 6 on the work spindle, and the 8 on the lead screw; but as gears are seldom, if ever, made with less than 20 teeth for interchangeable gear on engine lathes we must find a pair of gears that will give us the desired ratio.

Select one of the smaller gears, say 24, and divide it by the threads per inch on the lead screw (6), which gives us 4, and then multiply by the number of threads to be cut (8), which gives us 32 for the gear on the lead screw, or multiply both numbers 6 and 8 by any number for the gears required, as:

- 6×5 30 gear on spindle,
- 8×5 40 gear on lead screw.
- 6×6 36 gear on spindle,
- 8×6 48 gear on lead screw.
- 6×7 42 gear on spindle,
- 8×7 56 gear on lead screw.

By General Formula.

$$W \times S = L \times D \text{ or } D = \frac{W \times S}{L}$$

where

W=threads per inch to be cut.
S=number of teeth in gear on spindle,
L=threads per inch on lead screw,

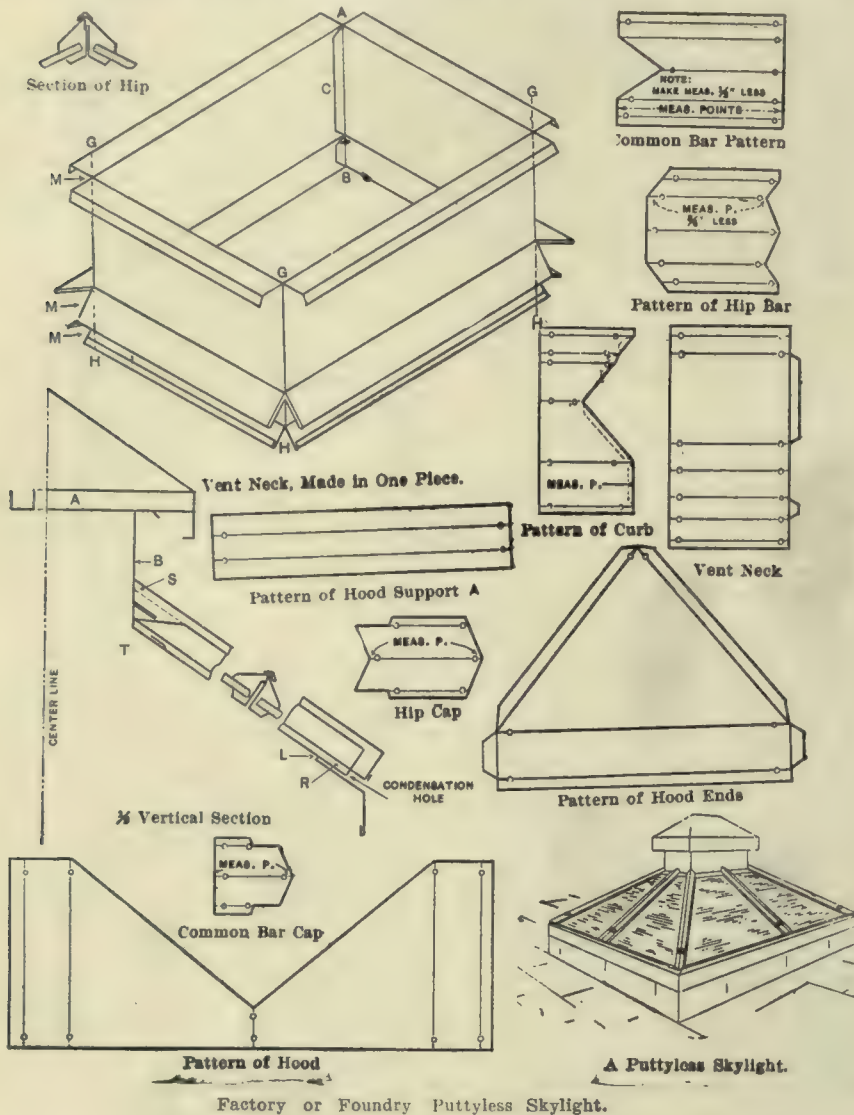

the corner A B meets the solder lap at C.

To ensemble, the four sides of the curb should be soldered together and the ventilator completed. After the four common bars have been soldered

light should now be turned over and the bars soldered at L and the hips at T. It is then ready to be turned back and the glass laid on. Now put on the bar caps and solder to vent at S, thus completing the skylight.

Screw Cutting on Engine Lathe Clearly Explained

Methods of Obtaining Different Trains of Gears Necessary to Cut the Various Threads are Given, Formulae being Illustrated with Examples.

By J. H. R., Hamilton.

Modern methods have to a great extent revolutionized this branch of the machine industry, and while this article will not appeal to the advanced class of machine operators, there will probably be some points which will prove of

considerable value to a great number of the readers of this paper.

An operator on a lathe of modern make, with instantaneous change gears, simply has to read an index plate, move one or more levers and the lathe is ready to cut the thread.

D=number of teeth in gear on lead screw.

Using in the above question

$$D = \frac{8 \times 24}{6} = 32 \text{ teeth.}$$

Suppose we have to cut a screw $3\frac{1}{2}$ thread per inch on the above lathe. An easy way is to figure on a 2 inch basis instead of one inch, thus removing the fraction, this will give 7 threads on the work and 12 on the lead screw.

By formula

$$D = \frac{W \times S}{L} = \frac{7 \times 48}{12} = 28 \text{ teeth.}$$

Select a gear for S that will be divisible by 12.

To cut a screw of $\frac{3}{8}$ -inch pitch (that is, 8 threads in 3 inches) on a 4-thread lead screw.

Threads in 3 inches on work=8.

Threads in 3 inches on lead screw= $4 \times 3 = 12$.

By formula

$$D = \frac{W \times S}{L} = \frac{8 \times 48}{12} = 32 \text{ teeth.}$$

To prove whether your gears will cut the thread.

$$W \times S = L \times D \text{ or } \frac{W \times S}{L \times D} = 0.$$

$$\frac{8 \times 48}{12 \times 32} = 0.$$

To find gears to cut a screw of 5-32-inch pitch with a 5-thread lead screw.

Threads in 5 inches on work=32.

Threads in 5 inches on lead screw= $5 \times 5 = 25$.

By formula, $D = \frac{W \times S}{L}$

Select a gear for S that is divisible by 25, thus—

$$D = \frac{32 \times 50}{25} = 64 \text{ teeth.}$$

Proof—

$$\frac{W \times S}{D \times L} = \frac{32 \times 50}{64 \times 25} = 0.$$

Suppose we have 24 threads to cut on a 6-thread lead screw. Smallest gear on lathe has 24 teeth. Largest gear on lathe has 80 teeth. Ratio of speeds= $24:6=4:1$.

By formula

$$D = \frac{W \times S}{L} = \frac{24 \times 24}{6} = 96 \text{ gear required}$$

for simple train.

As we have no 96 gear we must use a compound train.

Divide 96 by 2=48 for gear on lead screw. For the intermediate gears A and B, Fig. 2, use any pair with a ratio

of 2:1, as 80 and 40, 72 and 36, etc. Run the 24 into 80 and 40 into 48.

Proof of Correct Gearing.

Threads on work \times driving gears =

$$\frac{\text{Threads on lead screw} \times \text{driven gears}}{24 \times 24 \times 40} = \frac{6 \times 80 \times 48}{24 \times 24 \times 40} = 0$$

In the above problem the 96 could have been divided by any number, but whatever number is used as a divisor the ratio of the intermediate gears must correspond. Dividing by 3 the ratio of intermediate gears must be 3:1. Dividing

To Determine a Train of Gear to Chase the Spiral.

Threads on work in $9\frac{3}{4}$ inches=6. Threads on lead screw in $9\frac{3}{4}$ inches= $9\frac{3}{4} \times 4 = 39$. Ratio=6:39=1:6½.

Converting the 6½ into three factors (one single and two double factors) as $\frac{2(1 \times 2)(1 \times 1)}{8}$ which equals 6½.

Select a gear for the lead screw, say 40, and solve for the rest.

Take the first factor (2) and multiply by 40, which gives 80 for gear on the spindle.

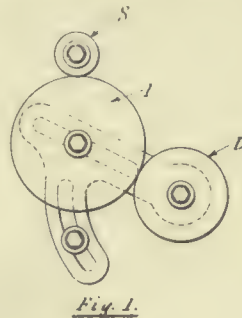

Fig. 1.

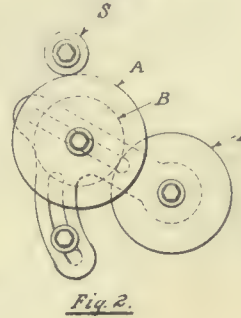

Fig. 2.

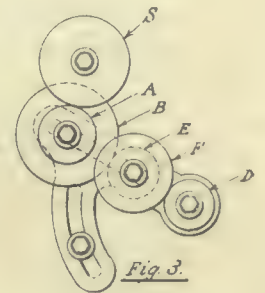

Fig. 3.



Fig. 4.

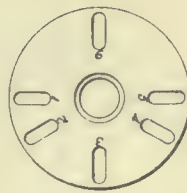

Fig. 5.

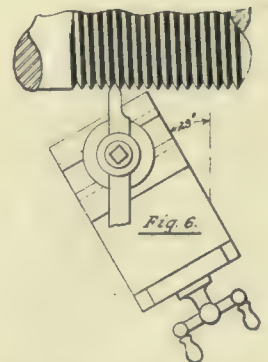

Fig. 6.

Screw Cutting in Engine Lathe.

by 4 the ratio is 4:1. Dividing by 2½ the ratio is 2½:1.

To cut a thread of 1-28-inch pitch on a 5-thread lead screw.

Ratio—28:5.

By formula—

$$D = \frac{28 \times 20}{5} = 112 \text{ gear on lead screw.}$$

for simple train.

Using 21-3 as a divisor,

$$112 \div 21 = 5 \frac{2}{3} = \frac{112 \times 3}{21} = \frac{112}{7} \times \frac{3}{1} = 48 \text{ gear for lead}$$

screw.

Intermediate gear ratio=21-3:1=70:30

Proof of correct gearing—

$$\frac{28 \times 20 \times 30}{5 \times 70 \times 48} = 0.$$

Sometimes a job will come along where one pair of intermediate gears will not solve the trouble, and another pair is necessary, as shown in Fig. 3. An instance in mind is several brass spirals which had a pitch of 1.625 inches, or 6 revolutions in $9\frac{3}{4}$ inches (to be cut on a lathe with a 4-thread lead screw).

Ratio of first pair of intermediate gears, as shown by the second factor (1 \times 2) is: 1:2=45:90.

Ratio of second pair, as shown by third factor (1 \times 1½) is: 1:1½=40:65.

Train of gears—80 into 45, 90 into 40, 65 into 40.

Proof of correct gearing, Fig. 3.

$$\frac{W \times S \times B \times F}{L \times D \times A \times E} = \frac{6 \times 80 \times 90 \times 65}{39 \times 40 \times 45 \times 40} = 0$$

Grinding Cutting Tool.

In cutting threads, especially those of coarse pitch, care should be taken to have the tool ground to the proper angle.

To find the desired angle proceed as follows: On a piece of tin draw an indefinite straight line, ab, Fig. 4; from C drop a perpendicular, CD, making CD equal to the circumference of the work measured at the root of the thread. On ab lay off ce, equal to the pitch of the screw; connect ed, then aed is the angle of inclination. Give the forward side f of the tool a little more clearance than this angle.

When cutting square threads of single or multiple, a narrow-nosed tool is usually used for roughing, and finish with one the exact size.

Fig. 5 shows a handy face-plate when cutting double, triple or quadruple threads, the slots being placed equal distance around the face.

When cutting V-threads a good way is to swing the compound rest, making an angle of 28 or 29 degrees, as shown in Fig. 6, with the cross-feed and using the compound rest feed for making the cut, as the cutting is done with one side of the tool, the other side just scraping. This in many cases will prevent tearing the thread.

Correspondence

Readers are invited to send in replies to answers asked under "Correspondence," and these will be paid for at regular editorial rates. Anyone desiring the names of firms manufacturing certain lines will be answered under this heading. Comments on previous articles containing good ideas will be paid for.—Editor.

Wire Springs.

I would like the address of a company who can supply me with a machine for turning continuous wire springs.—N. S. Subscriber.

Canadian Fairbanks Co., Montreal, are agents for companies manufacturing automatic spring coilers. If any other dealers handle such a machine we will forward their literature to the inquirer at their request.—Editor.

Oxy-Acetylene Welding.

I would like the addresses of firms in Canada handling oxy-acetylene apparatus.—Manitoba.

The Expanded Metal & Fireproofing Co., Toronto, handle the Davis-Bournonville apparatus and the Linde British Co., Montreal, handle the Linde apparatus.—Editor.

Hardening Steel Gears.

In the current issue of "Canadian Machinery" a manufacturer asks for a practical method of hardening steel cut gears, but the information given is a little vague to be of value in determining the method that should be employed.

Steel is a very general term. A few years ago, the Cutlers Co., Sheffield, took proceedings against a firm of manufacturers who were turning out table blades made from common iron, to which a small quantity of mild steel punchings had been added, and stamping them "Sheffield Steel."

In hardening steel, it is absolutely necessary to know the analysis of the material and just as necessary to have good practical appliances for uniformly heating and cooling the articles. The sketch given shows, I should judge, an article sufficiently expensive to justify a still further expenditure on a small hardening plant which would ensure a successful treatment.—F. W.

Power of Belts.

Do you know a good shop method for quickly calculating the power transmitted by belts? I would appreciate receiving same.—Tweed.

The following formulae give the horsepower which may be safely transmitted by belts:

$$\begin{aligned} \text{H.P. of single} &= \frac{w \times t}{600} \\ \text{H.P. of double} &= \frac{w \times t}{400} \end{aligned}$$

where w = width of the belt in inches, and t = number of feet belt travels per minute. Thus a single belt 3 inches wide running 300 feet per minute, will transmit $3 \times 300 \div 600 = 1\frac{1}{2}$ horse-power. A double belt 8 inches wide running 800 feet per minute will transmit $8 \times 800 \div 400 = 16$ horse-power.—Editor.

Cubic Inches in Gallon.

How many cu. ft. in a U. S. gallon, how many in an Imperial gallon? What are their weights?—Ontario Subscriber.

A U. S. gallon contains 231 cu. in., or .1337 cu. ft., and weighs 8.355 lbs. An Imperial gallon contains .1607 cu. ft., and weighs 10.042. It is generally stated that a gallon of pure water weighs 10 lbs.—Editor.

Vulcanizing Rubber Tires.

In reply to "Mildmay," we would advise him to read "India Rubber and Its Manufacture," by Herbert L. Terry. This book may be secured at the following address: "Technical Books, 10 Front St. East, Toronto." Chapter IV. is devoted wholly to vulcanization and the various methods. They are also treated under the various products. In chapter XVII. India rubber tires are dealt with, thirteen pages being devoted to tires.—Editor.

TECHNICAL EDUCATION COMMISSION FOR TORONTO.

The following commission appointed as a result of a conference of the Y.M.C.A., and other bodies interested in the industrial needs of Toronto, will investigate the requirements of commercial and technical education in Toronto:

Wm. Pakenham, B.A., Dean of the Faculty of Education in the University

of Toronto, chairman; R. H. Verity, general superintendent of the Massey-Harris Co., representing the Young Men's Christian Associations of Toronto; Frank Bancroft, a member of the educational committee of the Toronto District Labor Council; J. D. Allen, vice-president of the A. A. Allan Co., representing the Board of Trade; and Geo. A. Howell, of the Standard Paper Co., representing the Toronto Branch of the Canadian Manufacturers' Association.

The work of the Commission is as follows:

"The commission shall report upon the conditions and requirements of commercial and technical education, particularly of boys and young men, in the City of Toronto, and upon how those needs may be met. The commission shall also indicate how the Young Men's Christian Association may co-operate in providing for such educational needs." As the Toronto Y.M.C. Association are planning three new buildings, they have combined forces with other organizations in obtaining information to assist them in their educational courses, which will be carried on in their new buildings.

TECHNICAL EDUCATION COMMISSION.

Hon. W. L. McKenzie King has announced recently that a commission on technical education, consisting of probably five men, to have the widest powers of investigation, will be appointed by the Dominion Government. The commission will have authority to go to the United States, Britain, Germany and other European countries in search of information. They will then submit a worthy plan of technical education that may be taken up by the province. The Dominion will co-operate with the provinces as far as it can under the constitution.

BOUNTY ON WIRE RODS.

Hon. Mr. Fielding has given notice of the following resolution: "Resolved, that it is expedient to provide that no bounties shall be payable in respect to rolled round wire rods after June 30, 1911, under the provisions of the Act of 1907, respecting bounties on iron and steel, except on such rods as may have been otherwise entitled to the payment of bounties, and which were on or before the said date sold to wire manufacturers for use or used in making wire by the makers of such rods in their own factories in Canada."

D. J. Taylor, Regina, has been appointed manager of the Winnipeg branch of the Gould, Shapley & Muir Co., of Brantford, Ont.

POWER GENERATION ^{A_ND} APPLICATION

For Manufacturers. Cost and Efficiency Articles Rather Than Technical.
Steam Power Plants ; Hydro Electric Development ; Producer Gas, Etc.

CARE OF BELTS.

By J. H., Hamilton.

Leather belts being one of the greatest mediums for the transmission of power, the care and service of the belt and accessories should be one of the chief duties of the engineer, or man in charge.

Leather belts should always be run with the hair or grain-side next the pulley, as the strongest part of the belt is near the flesh side; the hair side being more brittle than the flesh side, the compression will come upon the inside of the belt when passing over the pulley. Wherever possible the driving portion of the belt should come upon the lower side, as the slack of the belt, caused by the extra tension of the drive will come on the upper portion of the belt, thereby giving more surface contact on the pulleys.

Where flanges are used to guide a belt, or in the case of cone pulleys, the face of the flange or cone should be undercut as shown at (a) Fig. 3, and kept clean. If dirt and grease are al-

rough. If a guide is necessary a roller should be placed in position instead of the stick, but a better way would be to remedy the cause of the trouble, which would likely prove to be a defective pulley, poor belt lacing or the shafting out of alignment.

Where belts run at a very high speed, care should be taken to have the pulleys run as true as possible. If the pulleys are not running true, the centre or crown is continually changing its position, and as the belt cannot follow this change fast enough, the belt will oscillate from side to side, especially if the belt is slack.

Belts may be fastened in several ways: By splicing and cementing making an endless belt; by lacing with leather lace and by the use of metal fasteners in many forms; leather lacing is the form most universally used, as it is flexible and runs smoothly over the pulleys.

Fig 1 shows a good way to lace a small belt, where one row of holes are used. First see that the belt is squarely cut so that both edges of the belt will be the same length. Punch the holes so

are used as shown in Fig. 3; the width of belt will determine the number of holes. The order of lacing is through 1, 2, 3, 4, 5, 6, 7, 6, 7, 4, 5, 2, 3, x, y; secure at Y.

The two halves should be laced together as it helps to keep the belt in position.

Where it is necessary to enlarge the holes for the laces, one hole should be punched directly behind the other, not side by side, as the belt will nearly always break across the lace holes, and as small a punch as possible should be used. Always have the straight part of the lacing on the hair or smooth side of the belt, so that they will come in contact with the pulley surface.

Where a belt has to be shifted from one pulley to another (especially on cone pulleys), metal fasteners should not be used, as it may prove dangerous to the hands of the operator.

When a belt is placed on a pair of pulleys it should be put on as shown in Fig. 4, so that when the splice comes in contact with the pulleys it will help to keep the splice together.

In the majority of cases where slipping takes place it will nearly always be on the smaller pulley (where pulleys are of the same material), and it will be seen that by running the belt as in Fig 4 it will help to preserve the splice.

By covering the pulleys with leather or some material which will give a greater friction, more power can be derived, but the covering should be glued or cemented on.

While repairing a belt some time ago, I noticed that it was nearly cut in two the full length, one of the pulleys had been covered with leather, and secured with tacks and nails; a few of the nails had worked out, and the slipping caused by the irregular strains on the belt had nearly ruined it.

As the pulley was on the main shaft I suppose the man responsible thought the pulley could do its own "driving."

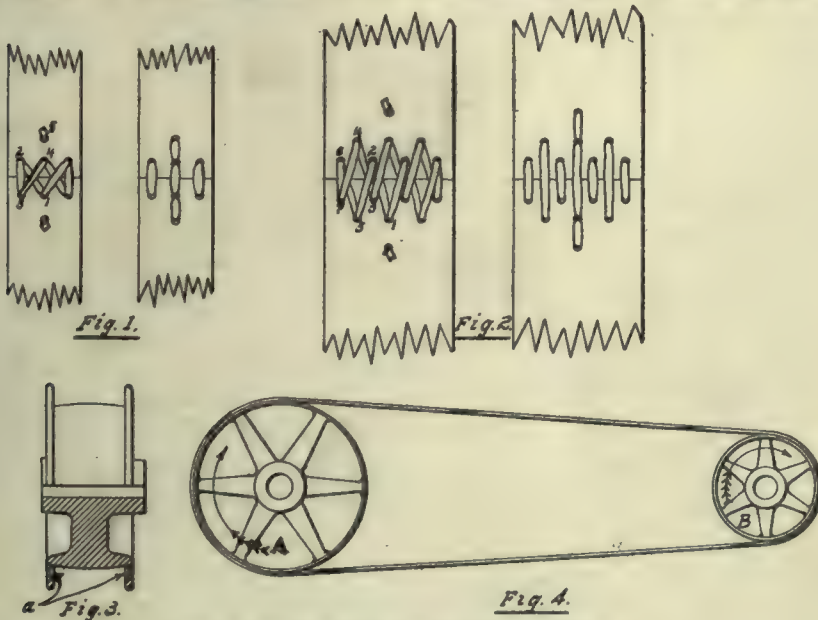

Care of Belts. Showing How to Lace them, etc.

lowed to gather on the face, the belt will be inclined to climb the flange, and if it succeeds in climbing it usually means a broken belt.

I have noticed on several occasions where a stick was secured to the ceiling to keep a belt from coming off. This is a bad practice, as in time the edge of the belt becomes worn and

that they are directly opposite each other.

Pass the lace through 1 from the under side then through 2, 3, 2, 3, 4 and 5, make a cut half way through the lace just clear of the hole 5, then about $\frac{1}{4}$ " out cut off the lace. Proceed in the same manner for the other half.

For large belts a double row of holes

COUNTERSHAFTS AND BELT DRESSINGS.

By L. Bailey.

Countershafts cut quite a figure in transmitting power to various machines and there is any number of clutch counters that are supposed to be far superior to the old tight and loose pulley class, and no doubt they are for slow

running machines, but for high speed such as is required for brass working tools there seems to be a want that has not been supplied up to date.

The writer has had considerable experience with countershafts with clutch pulleys on, of several different manufacturers, and I must say that I have not seen one that has been quite satisfactory. The difficulty seems to be that the lubricant throws off with the high speed and the counter being reversed quickly, cuts or grinds away the grip and the adjustment having to be made so often soon becomes exhausted.

There is also another defect, namely, the hub of the pulleys are too short on the side next to the clutch and the bore of the pulley soon wears taper and the belt will run on one side of the pulley so that when the clutch is thrown in, off goes the belt. Of course, a fellow don't mind that especially if the ladder is not handy, or Tom, Dick or Harry got the belt stick and forgot to bring it back. Well, perhaps some of my fellow mechanics have had better success than I, so I would like to hear from some of them on the subject.

A Belt Dressing.

It seems to me that this is something like patent medicines. We think that they are O.K. for a while, then something else comes along and so we keep trying new dressings. I have come to the conclusion that the castor oil treatment is best for the reason that when the so-called belt dressing is applied it is good for a while but soon wears off and another dose is needed.

When castor oil is applied, it goes right through the leather and makes it very pliable and also prevents the belt from slipping on the pulley.

When putting on a new belt it is often difficult to keep it on because of the slick surface and the stiff leather. To get over this difficulty when your belt is cut to length lay it down and give it a coat of castor oil and when you have put it on the pulleys it will stay.

POWER LOSS OF A SLIPPING BELT.

One often sees discussed the question whether or not a slipping belt is less economical of power than one which does not slip. If we consider that when a belt slips friction occurs between the pulley and belt, thus creating heat, it is at once seen that part of the driving power is "lost," as the radiation of this heat attains no useful end. Writing to the American Machinist, A. L. Campbell writes that the approximate amount of this loss may be obtained as follows:

A motor delivers ten horse-power to a line shaft by means of a six-inch double leather belt running 2,000 ft. per minute. The accompanying sketch shows the belt tension T to be 300 pounds on the tight side, while the tension T_2 , on the slack

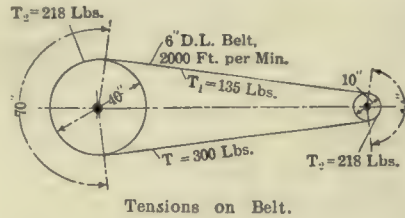

side is 135 pounds. The average belt tension T_2 will then be about the half sum of the other two, or 218 pounds.

The tension in the walls of a thin cylinder due to a uniform pressure is equal to the product of the unit pressure multiplied by the radius of the cylinder. Conversely, since the average

BELT TROUBLES.

When I took charge of a small lighting plant last June, says G. B. Kamps in Power, I found a 60-kilowatt, 2200-volt alternator driven by a 9-inch belt. The belt was cut, apparently, from an 18-inch belt and consequently the centre of the old belt came at one edge of the new belt. My predecessor evidently had had trouble with the belt because he used a guide made of pipe fittings as shown in Fig. 1. The belt ran very close to the housing of the machine and would rub very hard at times; the guide only made matters worse and opened the belt on one side as shown.

The belt was running with the laps. I turned it inside out and ran it for a while until the belt was straight. I then glued and pegged the edge of the belt and put it on as it was before but could not keep it on. I ran it with the

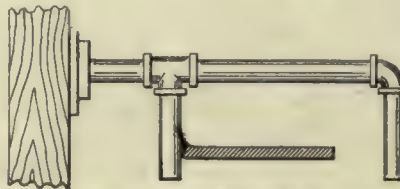

Fig. 1.—The Belt Guide.

laps, against the laps, right side out and inside out, but to no avail. As soon as the load would lighten, off came the belt. One night I was especially anxious to have the lights remain on when the load dropped off and knowing that powdered rosin or belt dressing was of no avail, I dug up an old mill file. When the belt started to "act up" I held the file down on the belt until the flying dirt and leather burned me. The belt stayed on with an occasional coaxing with the file.

I finally got over the trouble by cleaning the belt thoroughly and shifting the centre line of the alternator as shown in Fig. 2. The amount of shift must be very slight because the belt tends to crowd to the high side and work off if the angle is too great. I scraped the belt about once a week and applied a little neatsfoot oil after each scraping.

My pulleys are on 25-foot centres, the driving pulley is 5 feet 10 inches in diameter, and the driven pulley is 14 inches in diameter, the belt speed 4,900 feet per minute.

My experience has been that the cleaner the belt is the less it will slip, and that powdered rosin and belt dressings should be avoided. A little neatsfoot oil applied occasionally will keep the leather soft and pliable and will work the dirt out of the leather.

I use the following approximate formula: A single belt under a working strain of 60 pounds per inch of width, running 550 feet per minute, will transmit one horsepower for every inch of

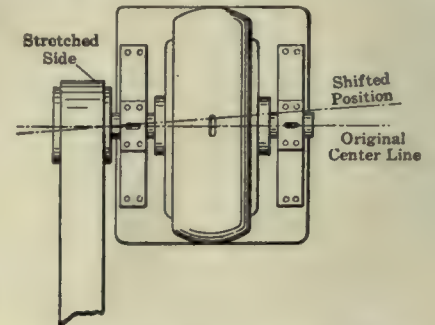

Fig. 2.—Centre Line of Alternator Shifted.

width. The pull, in pounds per inch of width, equals,

$$\text{H.P.} \times 33,000 \times \text{width of belt}$$

$$\text{Belt speed in ft. per min.}$$

For dynamo work, the pull or load per inch of width in single belts should not exceed 40 pounds under a speed of 4,000 feet per minute nor 32 pounds under speeds from 4,000 to 6,000 feet.

DON'T IGNORE SMALL THINGS.

Real economy is as important in small things as in great, but it is more likely to be neglected. People who are obliged to use a large amount of rope are compelled to study the rope market, and soon learn that it pays to buy the best and let the cheap stuff alone. This is likely to be overlooked by the small user because the amount involved is comparatively small, but it is a mistake to ignore the question. The reasons why a good rope is really cheaper than a poor one are just as true for the farmer who buys a piece of rope for his hay carrier as for the ship owner who buys it by the ton.

DEVELOPMENTS IN MACHINERY

New Machinery for Machine Shop, Foundry, Pattern Shop, Planing Mill; New Engines, Boilers, Electrical Machinery, Transmission Devices.

REVERSIBLE CHAIN DRIVES.

One of the disadvantages, if it may be termed as such, of chain driving happens when it is sometimes necessary to run the chain crossed, so as to give the driven an opposite rotation to the driver. Until recently this has been an impossibility, and the Coventry Chain Co., Coventry, England, have just put on the market a noiseless chain which can be crossed at centres over seven feet.

As shown by the detail cut the chain is perfectly symmetrical and it matters not which side is in contact with the toothed wheel. It will also be noticed that the chain has been lightened considerably by cutting out pieces of every link. This feature of lightness, combined with durability, will no doubt be interesting to the designer of flying machines as also will the fact that it can

erful hydraulic bending machines, which should prove of interest to all who have large pipe, structural sections, automobile parts, metal bars and similar sections to bend.

The frames and cylinders of these machines are cast iron and the cylinders are copper lined. The rams and bending pins are machinery steel. A positive stop is provided in both instances to prevent the ram from passing out beyond a safe limit.

The smaller machine shown in Fig. 1, is capable of exerting a power of 25 tons under a hydraulic operating pressure of 2,200 lbs. per square inch. The table is two feet long by 3 feet 4 inches wide and is provided with 18 round holes staggered in rows which are symmetrically placed with respect to the ram. Round pins each $3\frac{1}{2}$ inches in diameter can be placed in any of the

with the bending block higher above the table or by making the ram travel in guides, the centre line may be below the table. The cylinder head is removable



Fig. 1.—Hydraulic Bending Machine, Watson-Stillman Co.

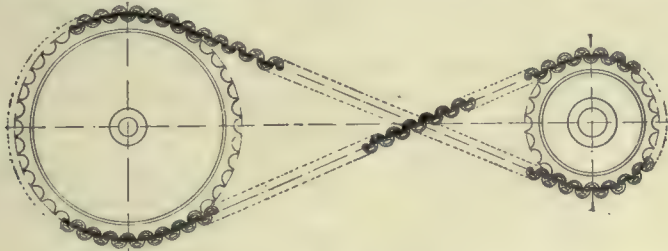

Reversible Chain Drive, John Milne & Son, Montreal.

be crossed and do its work at the high speed of 2,500 revolutions.

This is a new chain on the Canadian market and is being distributed by John

holes and the work may further be held to place by bolts set in any of the key slots on the top and sides of the table. Modifications of this table top are made

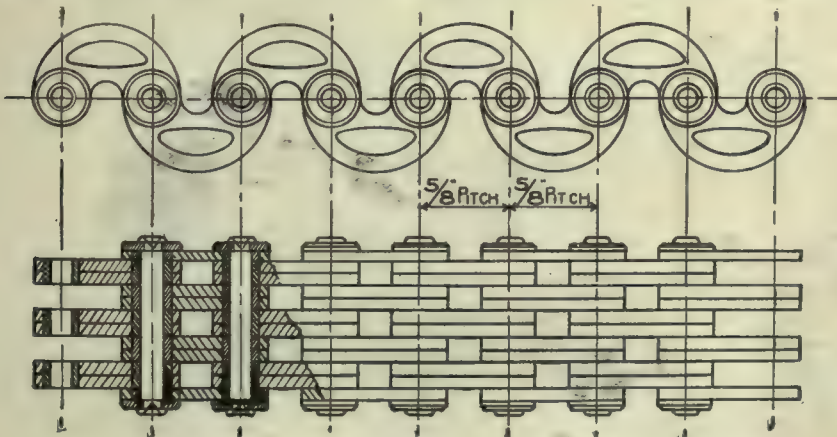

Construction of Chain for Power Transmission, John Milne & Son, Montreal.

Millen & Son, Limited, Montreal, along with their other lines of Coventry chains.

POWERFUL BENDING MACHINES.

The Watson-Stillman Co., of New York, has just introduced two new pow-

where necessary to conform to some special use.

The ram has a travel of 8 inches and is brought back to the beginning of the stroke by a counterweight. The centre line of the cylinder is $2\frac{1}{2}$ inches above the table, but this machine can be made

and provided with air passages for removing entrained air or draining if desired in cold weather.

Operation of the ram is controlled by a stop and release valve at the side of the cylinder.

The second bender, Fig. 2, is considerably larger and capable of exerting 30 tons pressure. In this instance the table is 4 feet wide by 6 feet long and has two opposed 7-inch cylinders of 12 inch stroke arranged to operate in either direction, the double headed ram extending between them.

The table as shown has 21 holes on each side of the ram and staggered in six rows. The movable pins are interchangeable and $4\frac{1}{2}$ inches in diameter. The larger or bending pin shown in the centre is attached to a saddle on the ram. The ram works in machined guides and is covered to prevent scale or dirt from reaching the contact surfaces. These surfaces are further protected from dirt by plugging the oil holes in the cover with screw plugs.

As in the smaller press the cylinder heads are removable and provided with air passages which also permit drainage. The valves are placed in one body and may be operated by any of the four levers at the corners of the press. The arrangement is automatic so that opening of pressure or release valves for one cylinder opens the opposite valve of the other cylinder, the movement being stopped by removing the hand from the lever.

A pair of bending blocks faced with a hard steel may be substituted for the bending pin. The cylinders are cast higher up for uses where it is desirable to obtain greater power. In this instance the rams are usually made inde-

owing to lack of room, and is therefore coming into quite general use in ship-building, bridge construction, machine shops, etc.

The novel construction of this jack is clearly shown in the illustration. For-

of great service in boiler work. With small modifications in the frame construction this tool can be put to many uses for which an hydraulic press is employed.

The details of the construction of this jack present many valuable and interesting mechanical features. On the left in the illustration is the pump and reservoir cross sectioned, in part, to show the valve construction. The pump is double acting with a working or pumping stroke on both upward and downward motion of the piston. There are two pump chambers the upper having about five times the capacity of the lower. The valves in the pump chambers are so arranged that on light loads the larger volume of water in the upper chamber is forced under the bottom of the same, causing it to rise through larger units of space than on heavy loads or overloads, when the smaller volume of water in the lower chamber is utilized. This speed adjustment is secured by means of an automatic bypass valve in the diaphragm between the upper and lower reservoirs which acts against a spring, which can be adjusted so as to allow the water in the upper pump chamber to escape at predetermined loads. This setting is generally at 25 p.c. of total capacity of jack, which corresponds to the lifting power which can be exerted by one man on large pump chamber.

To trip the load the operating lever is reversed so that the lug on the side projects upward allowing the lever to be pressed further down, causing the trip sleeve and pump piston to bear directly on the suction and discharge valves respectively, thus allowing the

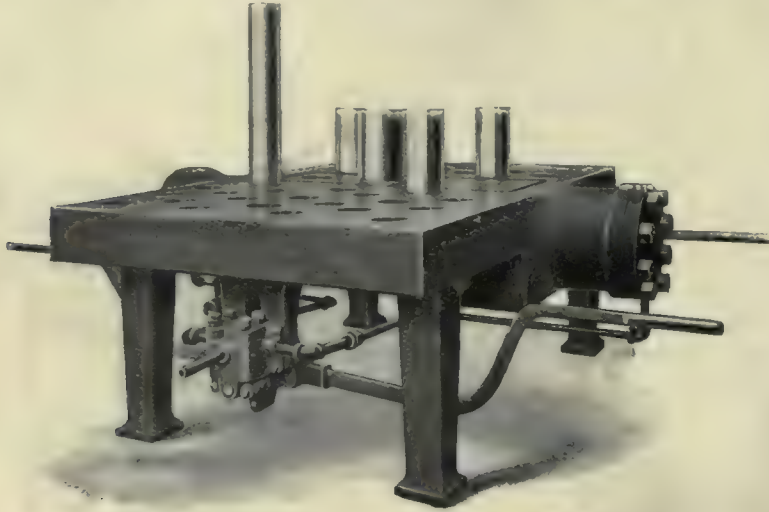

Fig. 2.—Large Hydraulic Bending Machine, Watson-Stillman Co.

pendent and single acting and are returned by counterweights similar to that shown on the small machine.

DUFF-BETHLEHEM HYDRAULIC JACK.

Something new in hydraulic lifting jacks is to be found in a design recently put upon the market by The Duff Manufacturing Co., Pittsburg, Pa. This jack is a powerful tool with lifting capacities ranging from 100 to 500 tons and a raise of from 6 to 12 inches. It is intended for use wherever it is inconvenient to operate an ordinary jack

ed steel is used throughout and the design is simple and compact. It consists of two main parts, the water reservoir with its pump chambers and the ram or lifting mechanism. These two parts are separate and distinct except for the flexible copper tubing which connects them. This arrangement allows the ram to be placed in any spot where there is sufficient room for it to rest securely, while the pump can be placed anywhere or at any distance permitted by the length of the tube, where it can be conveniently operated. Since the jack can be placed at any angle it is

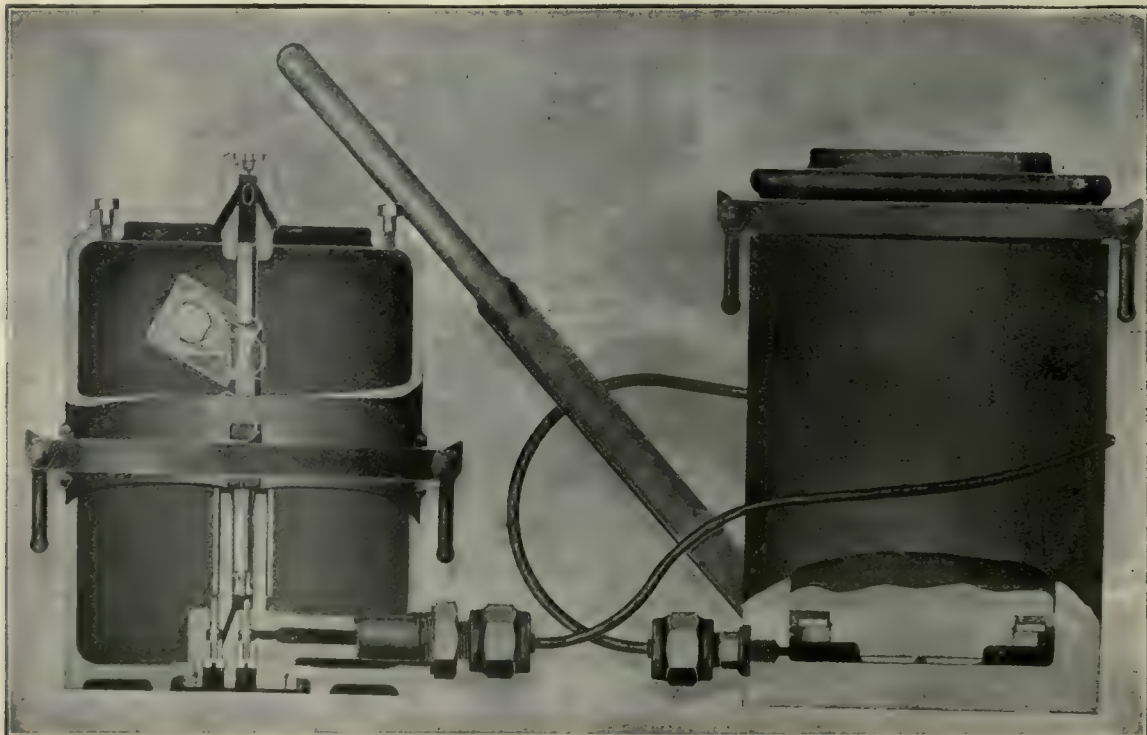

Duff-Bethlehem Hydraulic Jack.

liquid to pass back from the ram cylinder to the reservoir. The load may be lowered as slowly as desired or stopped at will by varying the pressure or lifting up on the lever.

Since the weight lifted by the jack is inversely proportional to the speed of ram travel the arrangement just described automatically adjusts the speed to the varying conditions of usage. The valve action is positive and there are no refinements of construction to cause trouble in a tool that is sure to receive rough usage.

The tube which loads from the pump to the ram cylinder is, as already stated, made of flexible copper and is guaranteed by the manufacturers to withstand a pressure of 10,000 lbs. per square inch. This tube is about eight feet long.

In the construction of the cylinder there are several features which make for efficiency and economy of maintenance. This cylinder is a solid steel forging there being no joint at its base

as in other makes. This design gives greater stiffness and strength with minimum weight and, what is more important, obviates the necessity of having a packed joint at the body of the cylinder. This joint is a fruitful source of leakage and is the hardest joint to make water-tight since it is the one subjected to the greatest pressure. This pressure varies, of course, directly with the load and with the distance through which the load is lifted, being greatest when the load is at rest at the extreme limit of travel of the ram. The only packed joint in this type of jack is between the ram and cylinder walls, where packing is easy and leakage less likely to occur owing to pressure being less direct and decreasing as the ram rises, being considerable when the load is at rest at the end of the lift. The valve and cylinder construction in the independent pump jack is not, however, peculiar to it but is characteristic of all the hydraulic jacks made by The Duff Manufacturing Co.

ing motion of the spindle is produced by the master working in engagement with a stationary guide, or shoe plate, with which it is held in contact by a spring. With the wheel and work in the corresponding relative positions at the other end of the spindle, it is evident that an exact reproduction of the model cam will result.

The slight change in the cam form caused by the reduction of the wheel by wear is compensated for by a set of change master cam shoe plates, which form part of the regular equipment furnished with the attachment. The contact or working surfaces of these is made of a regular curve form, with a consecutive difference of 1 in. in radius, which corresponds with the size of the grinding wheel at the different diameters as it is reduced by wear. The number of plates in a set is determined by the size of the machine on which the attachment is to be used—that is, by the diameter of the grinding wheel at full size and the smallest diameter to which it can be used. There is provided a change of plate for each inch of wheel reduction. In grinding the master cam a shoe plate and wheel of equal radius are used, which it will be seen must produce an exact copy of the model cam form; then placing the master in its proper position on the other end of the spindle, replacing the model cam and using the same grinding wheel and shoe plate or any other size of wheel and plate of equal radius, it will be seen again that an exact reproduction of the model or work will result.

As the wheel wears down the tendency is for the cams to become slightly full, which is practically imperceptible for 1-in. wheel reduction. The master shoe plates are so arranged as to distribute or evenly divide this variation. In this connection it must be noted that in making the master cam by using a wheel and shoe plate of equal radius the work will be reproduced precisely. For example, beginning with a full size wheel of, say, 14 in. diameter or 7 in. radius; with this a shoe plate on a

Developments in Grinding Equipment and Machines

The Landis Tool Co., Waynesboro, Pa., have recently Placed on the Market New Cam Grinding Attachments and a New Self-contained Grinding Machine, designed on Original Lines.

The Landis Tool Co. have brought out recently some new grinding attachments of interesting design. Figs. 1 and 2 show a cam grinding attachment for detachable cams which has been designed for use on the company's regular universal and plain grinders. The application to the machine is made by simply clamping the attachment to the table and connecting the driving arm on the end of the spindle with the regular driver on the face plate of the grinder, as is clearly illustrated by both views. It is constructed so as to swing, the spindle head being suspended from a hinge bearing directly above; the work and master cam are mounted on the same spindle.

An important feature of this attachment is that it grinds its own masters, which are copied from actual size model cams of the work to be ground. In making the master cam it is mounted on the working end of the spindle, while the model cam serves as a master on the other end; this operation is exactly the same as illustrated for grinding the work. This method insures the making of an exact copy of the form of the model cam, consequently a perfect duplicate of the work is obtained. The master is enlarged and the cylindrical portion is never less than 3 in. in diameter; this, in the majority of cases, makes the size more than double that of the work. The swinging or oscillat-

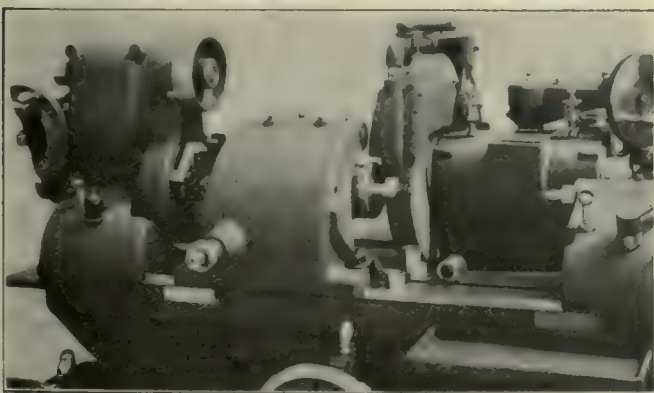

Fig. 1.—Working Side of a Landis Grinder With New Cam Grinding Attachment.

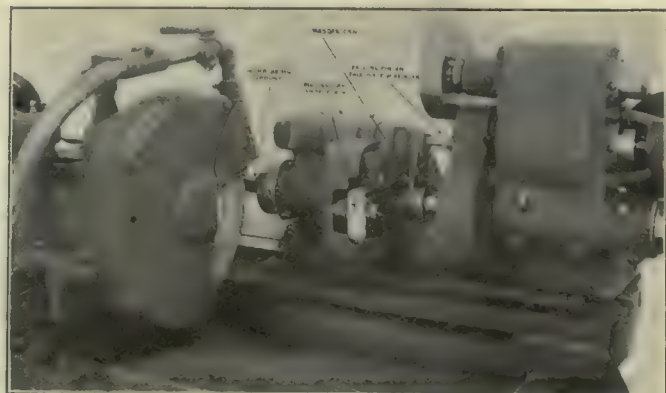

Fig. 2.—Rear View Showing Master Cam and Shoe Plate.

6½-in. radius would be used; wearing the wheel down to 13 in. in diameter or 6½ in. radius makes it ¼ in. less than the shoe plate, and this difference being equal to the amount that the wheel was larger than the shoe plate in the beginning, it will be clear that the slight variations of the cam will be divided equally by a true line of the cam form. When the grinding wheel has been worn to 13 in. in diameter, the shoe plate is changed for one made

cam grinding fixture applied. A master or former cam is placed at the rear of the machine and is rigidly supported by bearings bolted to the back of the main column or bed, and is driven in unison with the work by gearing from the headstock.

In this machine, instead of swinging the work from or toward the wheel to produce the cam form, the grinding wheel head is moved by a cross reciprocating motion actuated by the master

of the cam forms are obtained on the master. The body of the master is large in diameter, and for most work the cams are more than double the size to be ground. A portion of the body of the master remains between the cams in the form of a collar. When the grinding wheel is traversed along the work in passing from one cam to the next the roller on the rear of the slide mounts these collars and while in engagement grinding wheel is withdrawn clear of the work and no cross motion is given to the slider. When the wheel has been moved to the next cam to be ground the roller passes beyond the collar of the master and engages the corresponding master cam.

The reciprocating cross motion of the grinding wheel only takes place when it is moved to the cam to be ground. It will be seen that the grinding wheel can be traversed along the work automatically just the same as in grinding a plain piece.

The cam grinding fixture in no way interferes with plain straight grinding, and the machine can be used for grinding the line bearings of the cam shafts to the same advantage as if this part of the work were done on a regular plain grinder.

Self-Contained Grinding Machine.

The last four illustrations show another new grinding machine designed on original lines and built by the Landis Tool Co., Waynesboro, Pa. This is a 16x72 heavy duty self-contained grinding machine.

Throughout the entire machine it is of the high power and heavy duty construction and while intended for finishing all classes of work within its range it is especially adapted for grinding chilled rolls. The regular practice in grinding this work for grinding the body, is to support the roll by its journals on bearings mounted on the table of the machine. Previous to this operation the journals or necks are themselves ground, which is done with the roll carried on centres in the same manner as for regular plain grinding. The grinding wheel is 24 inches in diameter and the guard is made to take these with faces up to 4 inches wide. The wheel can be used at full size in diameter for grinding 16-inch rolls, which occupies the full swing of the machine. To compensate for any slight error in the alignment of the headstock and roll axes and to avoid any tendency of the drive to influence the roll from its true axial position, with the bearings, an equalizing fixture is attached to the face of the headstock which drives the roll with equal force from opposite points across the centre. In roll work it is well known the importance of the roll face being true and concentric with the journals; to be assured of this

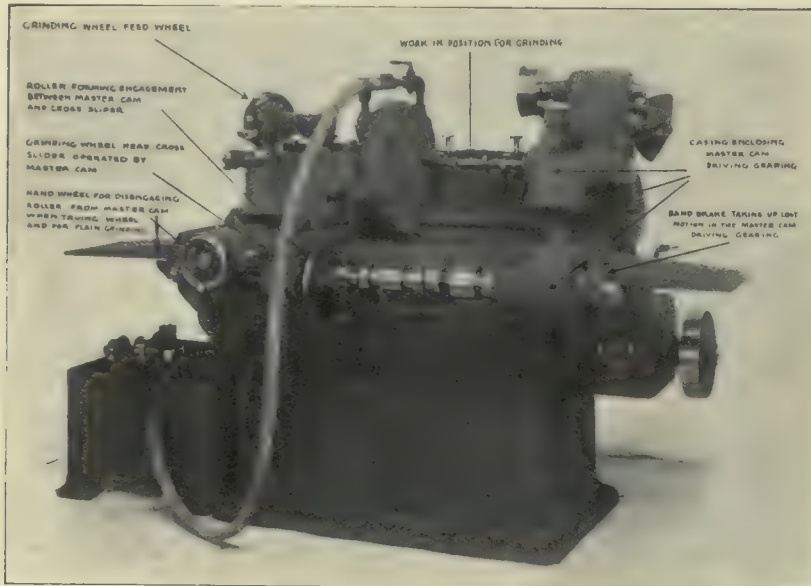

Fig. 3.—Special Landis Cylindrical Grinder Arranged for Grinding Cams Integral With the Shaft

on a 6½-in. radius; at 11 in. in diameter, 5½-in. plate, etc., and these changes continued until the wheel is reduced to its minimum diameter.

Cam Grinding Machine.

Fig. 3 shows the principal view of the Landis cam grinding machine which has been designed especially for grinding cams made integral with their shaft, but will handle detachable cams with equal facility. In arranging it for the loose cam work in the majority of cases the master cam is so made that a full set of either the inlet or exhaust cams can be placed on an arbor and ground at one setting.

This machine is substantially the regular 10 x 30 in. plain grinder with the

cam and the work is carried by the regular stationary centres of the machine.

A separate master must be made for each style of cam shaft, which is copied from a model of the work by the machine itself. In the operation of producing the master the model shaft takes the place intended for the master on the machine and is supported rigidly between the cams its entire length, to avoid any possibility of its yielding or springing during the grinding operation of the master. The master cams are ground with their shaft between centres in exactly the same manner as the work itself is held. It will be evident that by using a perfect model of the work to copy from exact duplicates



Fig. 4.—Front View Landis Grinder.

when finishing on the grinder the above described method has been found to be the only practical and reliable one. Another feature contributing greatly to the making of accurate work is, the stationary work table which is supported its entire length by the main column of the machine.

The bearings for supporting the rolls when grinding the bodies and the equalizing driving fixtures are not shown by any of the illustrations, but become regular parts of the equipment when the grinder is furnished for roll work.

Useful for Railroad Work.

This machine is also adapted for railroad shop work for grinding locomotive pistons, piston valves, valve stems, crank, link and knuckle pins, axles, etc. It is provided with a gap, as shown by Fig. 6, so that pistons can be ground with their heads in place and also for the swing of valve yokes when grinding the stems. The gap can be located along the table to suit the work when the machine is built. The machine is of the self-contained type and is designed to be driven either by a motor or from the line shaft.

Fig. 7 shows the arrangement of the electric drive as well as showing an end view of the machine when provided with a gap for locomotive work.

With either form of drive the power is applied to the main shaft at the rear of the machine from which it is distributed and transmitted to all of the different working parts. The grinding wheel is driven from the large pulley seen in the rear view, Fig. 5, located at about the centre of the machine, which is mounted in a carriage rolling on the track shown extending from the base of the machine and travels with the wheel carriage as it is traversed.

This pulley is driven by step grooves on the main shaft engaging rollers in its sleeve or hub which makes practically a frictionless drive as it is traversed or slides over the shaft.

The grinding wheel belt is 6 inches wide and passes over intermediate pulleys so arranged to automatically take up any change in its length and at the same time keep it under a uniform tension.

This belt is almost 200 degrees contact on both the driving and driven pulleys and its length can change about 8 inches by stretching before necessary to remove a section and shorten.

The grinding wheel head is massive and rigid which is a feature so essential to rapid and perfect grinding. The spindle is of very large dimensions and is made of hardened steel; the bearings are of phosphor bronze, are self-aligning, are adjusted in tapers for taking up wear and have self-oilers. A very important feature of this wheel head is that the bearings are protected

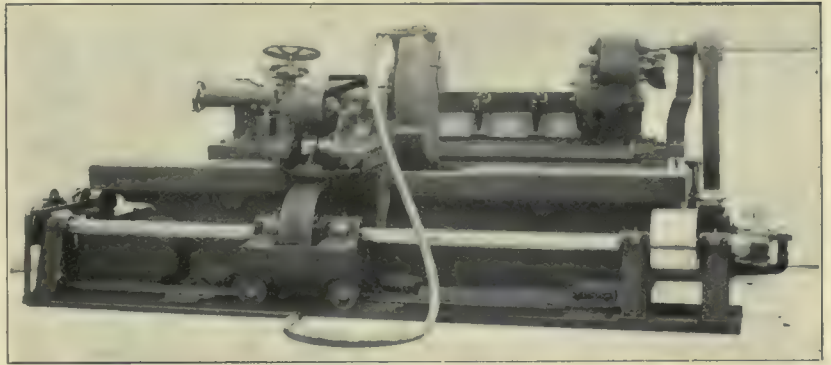

Fig. 5.—Rear View Landis Grinder.

by special covers and are positively dirt proof. The grinding wheel has provision for balancing, this being done by two weights mounted to be adjusted in a circular or annular groove in the side of the wheel collar or centre.

The headstock is very powerfully geared and has ample power for driving the largest piece of work or roll that

the changes can be made quickly and with ease. All parts of the clutch mechanism are made of hardened tool steel and all gears are finished by planing.

The work revolving and traversing mechanism are driven from the gear box at the end to which power is delivered by the belt from the main shaft as is also shown by Fig. 7.

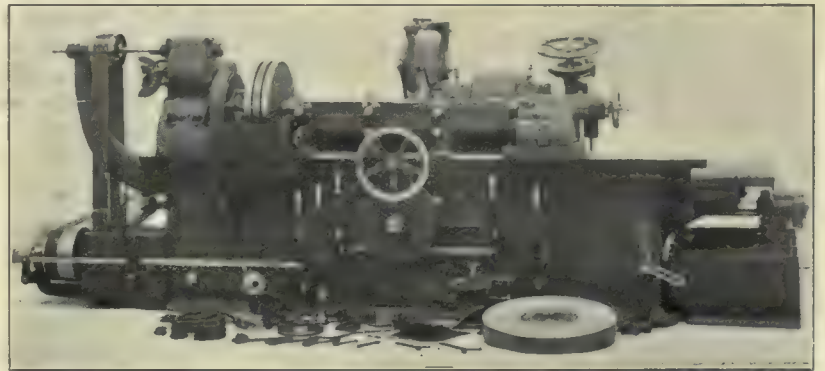

Fig. 6.—Landis Grinding Machine With Gap, Front View.

can be placed in the machine. It is arranged to give five changes of speed to the work, these being made mechanically by the movement of a single lever, and by shifting a back gear in the gear box at the end of the machine seen in view Fig. 7, another range of five speeds is obtained, making a total of ten work speeds. These speeds are indicated on a dial as will be seen by Fig. 4 and

The work and traverse drives of the wheel are started and stopped together by a clutch in the pulley on the end of the gear box which is operated by a lever at the front of the machine. These drives can also be operated separately and their speeds are varied entirely independent of each other. The pump is driven from the end of the main shaft as will be seen in views Fig. 4 and 5.

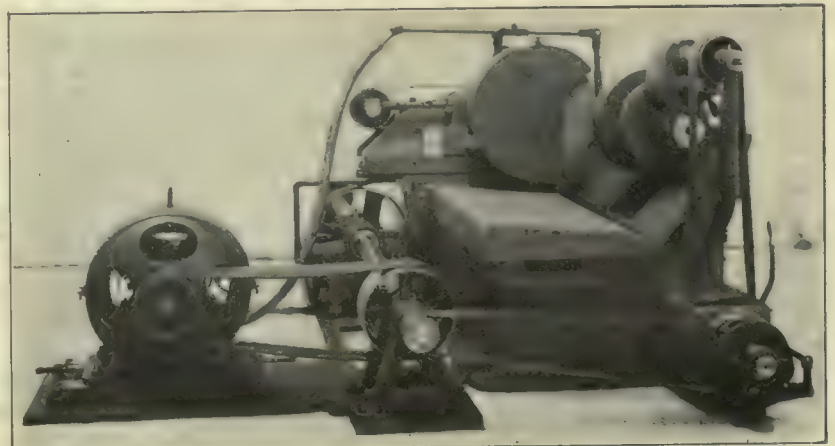

Fig. 7.—End View Landis Grinder, Motor Drive.

FOUNDRY PRACTICE AND EQUIPMENT

Practical Articles for Canadian Foundrymen and Pattern Makers, and
News of Foundrymen's and Allied Associations. Contributions Invited.

A. F. A. CONVENTION AT DETROIT.

The Detroit Convention, June 6 to 10, promises to eclipse all previous conventions. At a meeting of the Detroit Foundrymen's Association, held April 21, a general review of arrangements were given by the heads of the committee. Discussing the general preparations Dr. Stephenson said:

"In a general way I would say that, without any undue egotism on the part of our local organization, we can say that never in the history of the American Foundrymen's Association has the convention detail been so well covered as it is at the present time; this is the opinion of all those who are in touch with the situation, as it has developed, in the previous conventions. I find that statement reiterated in the letters which come to me, and in my associations with men identified with the foundry interests throughout the country.

"The badge matter will be handled to the satisfaction of the local committee. The State Fair ground matter has been pretty well taken care of. All present booths will be taken out of the Administration Building. Mr. Hoyt tells me that the demands for space are far greater than has ever before been made, and he is figuring on the advisability, the last time I saw him, of using a tent.

"We have about decided to have the General Registration Headquarters and the reading of the papers to take place in the Michigan Building. The temporary building is not fully decided upon, but if the fair organization pulls out the present administration quarters in the main building, that will probably give Mr. Hoyt room to erect a smaller temporary building."

Plant Visitation.

It has been arranged that every plant will take care of every delegation which visits the various plants and show them around. The idea is to have the headquarters of the Visitation Committee at the Fair Ground and also at the Pontchartrain Hotel. Anyone who wishes to visit any of the plants in the city or any group will simply go to the Plant Visitation Committee, to whoever is in charge and so state, that they wish to visit such and such a plant. A card will be issued to them or to the leader stating that Mr. Blank with a dozen or 15 others will visit the plant and be shown through.

Information for Members.

The information that will be given to

every member will be something like this: A folder in the middle of which will be a map of the City of Detroit, a complete map showing the car lines, the location of the plants to be visited. It will show the hotels, parks, theatres, railroad stations, and other points of interest to the visiting members. Over on the side will be a list of every plant which has signified its willingness to be visited, for instance—Russel Wheel & Foundry Co., will state where it is and an arrow will point directly to R. W. & F. on the map, and also the general direction, what car to take, when to get off, etc., etc. When the little group arrive at the plant, they present the card and are shown through by some representative of the firm, who will be provided for that purpose. This folder is in the printers' hands at the present time. It will give a man or one or two dozen men an opportunity at any time he has during the convention which he might select, to visit those plants.

There will be, however, 1 or 2 of the largest companies in Detroit who will be visited in a body. The Solvay Process Co. have invited the Foundrymen to visit the coke plant, and the Detroit Iron & Steel Co. have also signified their willingness to have members visit their blast furnaces, and will endeavor at that time to have a cast, if possible. These are the only two plants which will be visited in a body.

The boat-ride committee has chartered the Steamer Columbia, with a capacity of 3,400 people, which will take care of the crowd. Details of that ride are not yet settled, but the idea is to take the ride and show the visitors the City of Detroit, up around the island, giving them the view of the east side of the city, returning down, making a stop at the dock of the Detroit Iron & Steel Co., and Solvay Process Co., those wishing to go ashore at these places may go, those not wishing to do so may stay aboard, going down to the Livingston channel, which is rather an interesting piece of work. Then going back and picking up the visitors at the Coke ovens, coming back in time for dinner.

Entertainment.

Some excellent papers have been arranged for and the general discussion will add greatly to the educative features. The smoker will be the "best ever," a feature being the gift of a stein to each attendant.

The idea is to start after luncheon at noon and bring them back for dinner at 6 o'clock. There will also be a boat for the evening, which will leave the dock at 7.30 or 8 and return between 11 and 12. There will be music on the boat, both afternoon and evening, and dancing if desired.

On Monday night, the first night of the convention, it is planned to give a dinner at the Pontchartrain for the officers of the allied associations, that is to the American Foundrymen's Association, the Brass Founders' Association, the Foreman's Association, and a few representative members of the Technical Press, which will probably (including the Officers of the Detroit Foundrymen's Association and the chairmen of the General Committees) number about 65 or 70 people, possibly 90.

MAGNETIC METAL SEPARATOR.

The magnetic metal separator shown in Fig. 1, is manufactured by J. W. Paxson Co., pier 45 north Delaware Ave., Philadelphia. It is a simple machine, valuable for the separation of iron turnings, filings, etc., from brass, composition iron from emery, granular rubber, ores and other materials, and it is doubtless capable of various other applications.



Fig. 1.—Magnetic Metal Separator, J. W. Paxson Co., Philadelphia.

The magnetic wheel shown in Fig. 2 and over which the mixed metals fall contains 300 magnets, to which the iron adheres; the iron is then carried to the brush cylinder (Fig. 3) and there re-

moved, while the brass and other materials fall into the box shown in Fig. 1.

The capacity of No. 1 machine is from 1,500 to 2,000 lbs. in 10 hours, according to stock; No. 2 machine 3,000 to 4,000 lbs.; No. 3, 6,000 to 8,000 lbs.

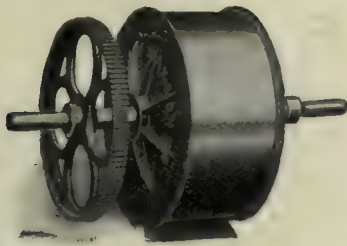

Fig. 2.—Magnetic Wheel, J. W. Paxson Co., Philadelphia.

In starting the driving shaft should be run 90 to 100 turns per minute. Size of pulley, 12 inches in diameter; width of face, 2 inches; a belt 1½ inches in width will be sufficient to drive the machine.

Two important points must necessarily be observed in the use of the machine: (1) Remove the iron bands and replace them whenever the machine is not running; raise also the brush. When it is running, do not drop brush too low, as it will wear out the brush and brass too quickly.



Fig. 3.—Brush Cylinder, J. W. Paxson Co., Philadelphia.

(2) The tray under the hopper should strike equally on each side, so as to distribute the stock evenly on the wheel. If you wish it to feed faster, draw the hopper forward. Place the boxes as shown in Fig. 1. The material in the middle box should be run through the second time.

TRYING IT OUT.

Many managers of shops and foundries are afraid to try novelties and it is certain that there is danger of a man going to the extreme in forever chasing new hobbies. Advancement, however, comes to those who study and try to keep abreast of the times.

Recently in visiting a plant where they were using a number of new things it was remarked that they had many handy kinks. The manager replied, "Some people may call us easy but the reason we have so many time-saving devices is because we always give our

time to listen to anyone who comes here and claims that he can improve our practice. If the device shows any merit, we buy it; we follow this rule even with the man who comes around with the "secret process" and the "special method." We often pay a fellow five or ten dollars and find that we have not received much. Occasionally we find some one who gives sufficient information to more than compensate us for the trouble and expense we have had with the others. Not long ago a man came in and told us that he could show us a kink that would make a material saving in one of our presses. We asked him how much he wanted for instructing us. He replied "Ten dollars." His device saved us at the least calculation \$250 in the next three months."

That is an illustration of what a careful man may pick up from those who come to the plant. There is a class, however, which is to be avoided as their claims are preposterous and incapable of either proof or support.

Another cases which has come under our attention was that of a foundry foreman who had been with the plant since the early days when it had to

SOLVING SPOILED WORK PROBLEM

In an agricultural works there is a great deal of small foundry work. It is often a problem to look after the spoiled work and secure the total number of good castings. In the Frost & Wood Company's foundry at Smith's Falls, this has been provided for in a satisfactory manner.

The molders work piece work and the adjustments are easily made. There is a daily run, after which the castings are taken to the grinding room. Here the bad ones are culled out from the good. The timekeeper makes a list of the pieces giving the pattern number and number of pieces. The broken castings are then taken to the charging floor of the cupola.

The time-keeper makes out a list such as that shown herewith giving a list of the spoiled parts and the check number of the molder. The broken castings are deducted from the number sent in on the molder's piece-work slip. In order that a molder may know exactly how he stands, the sheet of "spoiled parts" is hung, each day, beside the check box.

With this system of looking after

SPOILED PARTS.

Dept. _____ Date _____ 19__

CHECK No.	PATTERN	PIECES		CHECK No.	PATTERN	PIECES	
		CULLS	DISCOUNT			CULLS	DISCOUNT

Sheet 7" x 10" for Listing Spoiled Parts.

struggle for its existence. He has devised a number of methods including some special machines which in those days had saved the company a good deal of money. Later on certain patent devices were brought out and the prosperity of the firm was made sure. With the development of the manufacturing operations the foundry grew to be a large proposition and it became necessary to introduce molding machines and other latest labor-saving appliances. The foreman, confident of his past success, was not any too receptive to take instruction in these new ideas. Neither did he see the advantage of visiting other plants. Naturally he felt that he was an A-1 foundryman and was frankly of the opinion that "he was just as bright as the next man you'll find."

A visitor in walking through the plant could not but notice that in some respects the practice was the latest and best while in others it was antiquated. The only men who are able to hold a reputation for stability without continued effort in their respective positions are those who rest in the graveyard.—Castings,

spoiled parts it is a simple matter to keep track of the total number made. When a requisition comes to the foundry for a certain number of castings, the number is written on a standard sized card and filed according to pattern number. When the spoiled parts are listed the number of the culls is deducted from the number sent in by the molder, and the number now left is listed on the total card. At any time, therefore, the foreman can tell how the work stands in his shop and how many good castings of any particular pattern have been made.

W. Norris, formerly of the London Street Railway, has accepted a position as manager of the Chatham, Wallaceburg & Lake Erie Electric Railway with headquarters at Chatham.

Owing to the illness of David Bain, superintendent of the Gananoque Axle Co.'s works, Gananoque, Thos. Scott, who for several years has been in charge of the company's warehouse, has been promoted to the position of assistant superintendent.

Three New Machines to be Exhibited at Detroit

The Adams Company, Dubuque, Iowa, will show Some Interesting Foundry Equipment at the Foundrymen's Convention at Detroit, June 6 to 10.

Three interesting machines that will be shown at the Detroit Foundrymen's Convention are the new Farwell Pneumatic Roll-Over Molding Machine, the new Farwell Squeezer designed for use with Keep Hinged Match Plates, the new 24 in. Stationary Farwell Squeezer with improved type of table and the new 34 in. Portable Heavy Duty Farwell Squeezer or Plow Point Machine.

Fig. 1 shows the Farwell Pneumatic Roll-Over Molding Machine without pattern. This machine jolts the mold as well as turning it over and drawing pattern. The combination of these features in a portable machine is new. You will note from the illustration that solid cast iron wheels are used, since they serve as an anvil on which mold is jolted. The wheels run on a track imbedded into the floor, thus affording an ample foundation at small expense, and without necessitating a permanent location of machine at one place.

The angle iron arm or table resting on the wheels carries the pattern and each side is provided with a heavy steel block, A, which receives the shock when mold is jolted. The holes in this angle iron are for the purpose of attaching the pattern which is clearly shown in Fig. 8.

Fig. 2 shows the flask in place, filled, ready to jolt.

Fig. 3 shows the operation of jolting which is accomplished by admitting air to the cylinder and exhausting, both of which operations are performed with the same valve, enabling the molder to control the machine entirely with one hand. After jolting and striking off, the bottom board is placed in position and secured by means of the adjustable clamps which are attached to the match board.

Fig. 4 shows the next operation. The molder opens the air valve again, admitting air to the cylinder and raising the mold to dead centre. After passing this point, the mold is lowered on to the cross pieces, B, by allowing air to escape. This can be done as quickly or as slowly as is desired.

Fig. 5 shows the mold as it has reached this position. The four plungers, C, are provided with springs which automatically equalize or adjust themselves to the irregularities of the bottom board on all four points, and as soon as mold rests upon the cross pieces, B, these plungers are locked in position by a single movement of the lever, D, which

is connected by links to all four plungers. This lever, D, may be kicked into locking position with foot. The molder now releases the clamps and is ready to draw pattern.

Drawing the Pattern.

Fig. 6 shows the operation of drawing the pattern. The molder operates the air valve which admits air to the cylinder with his right hand, and with his left hand opens a pet cock, admitting air to the Adams Pneumatic Rapper which is mounted on the frame work carrying the pattern. The pattern is drawn perfectly straight to any desired height before starting to roll over, and this combined with the pneumatic rapper and the steady air control insures a good clean lift. It will be seen that as cylinder, E, is raised by the air pressure within, the pattern will be drawn straight until the yoke, F, strikes the pin, G, when the yoke must stop, making a fulcrum of the pin, H.

Fig. 7 shows how the machine operates from the point on, the pattern describing an arc.

Fig. 8 shows the pattern as it has just passed dead centre, rolling back to its original position, ready to receive new flask and start on another mold.

The special features of the Farwell Pneumatic Roll-Over Molding Machine, are its great simplicity, the method of instantly clamping the plungers, so that the mold rests evenly thereon, the elimination of expensive concrete foundations, portability, the hinged clamps, easy control and the use of the Pneumatic Rapper in drawing the pattern.

Farwell Squeezer.

Fig. 9 shows the new type of Farwell Squeezer that has been developed for use in connection with the Hinged Match Plate system invented by W. J. Keep, superintendent of the Michigan Stove Co., Detroit.

This machine will be placed on the market for the benefit of those who adopt the Keep system and the Adams Co. will supply the squeezers as well as special equipment required to all foundries who are licensed to use Mr. Keep's invention.

The Keep system employs hinged snap flasks and a match plate provided with lugs which fit into the hinges of the flask, thus making it possible to roll up the cope and the pattern. In order to allow for this, the squeezer top is arranged so

that it will swing farther back and the table is provided with a special flask supporting device not shown in the photograph. The flask supporting device operates two pins which support the back side of the drag when the cope is rolled up. This is necessary in order to prevent the drag from being tilted by the weight of the cope.

Stationary Squeezer.

Fig. 10 illustrates the new 24 in. Stationary Farwell Squeezer which is very similar in construction to other Farwell Squeezers except that the table is raised higher above the rocker shaft, and it is not necessary for the top to swing through so great an arc in clearing the table. This makes it easier to bring the top forward into squeezing position, while the new form of table brings the mold up above the links which connect the rocker shaft with the side arms, thereby making it possible to use a larger flask in proportion to the width of the machine, and removing the danger of molder striking his knuckles against these links when ridding sand. This machine, which measures 24 in. between side rods, will take a flask 18 in. long or within 6 in. of the width of the machine, whereas on the ordinary 30 in. squeezer which measures 30 in. between side rods, flasks longer than 22 in. are not handled conveniently.

Plow Point Machine.

Fig. 11 illustrates the new 34 in. Portable Low Down Heavy Duty Farwell Squeezer or Plow Point Machine. This type of machine has in the past been built in 30 in. and 38 in. sizes only, and the 34 in. machine is a new addition to the line, possessing some special features not found on the other machines. The principal improvement on this 34 in. machine is the new style of counterbalancing spring which is adjustable to any tension. This spring can be set so that the squeezer top comes forward of itself, but, of course, it is ordinarily adjusted so that the top stays back out of the way until the mold is ready to be squeezed, when it is brought forward by a very slight pull. The leverage of the spring is so arranged that practically no effort is required either in pushing the top back or pulling it forward.

GLUTERIN MANUFACTURED IN CANADA.

The Robeson Process Co., Au Sable Forks, N.Y., recently began the manufacture of Gluterin, a sand binder, at Grand Mere, P.Q. Francis Hyde & Co., 31 Wellington St., Montreal, are selling agents for Canada.



THREE NEW FARWELL MOLDING MACHINES, DUBUQUE, IOWA.

- Fig. 1.—Farwell Pneumatic Roll-Over, Molding Machine.
- Fig. 2.—Flask in Place, Farwell Molding Machine.
- Fig. 3.—Operation of Jolting, Farwell Molding Machine.
- Fig. 4.—Raising Mold to Dead Centre, Farwell Molding Machine.
- Fig. 5.—Mold at Dead Centre, Farwell Molding Machine.
- Fig. 6.—Drawing the Pattern, Farwell Molding Machine.
- Fig. 7.—Describing Arc, Farwell Molding Machine.
- Fig. 8.—Pattern Rolling Into Original Position, Farwell Molding Machine.
- Fig. 9.—Farwell Squeezer.
- Fig. 10.—24" Stationary Farwell Squeezer.
- Fig. 11.—Plow Point, Heavy Duty, Farwell Squeezer.

PIG IRON ANALYSIS.

In small foundries, it is customary to take the analysis of the company from whom the iron is purchased. A chemist cannot be engaged on account of the cost. For some work the analysis made at the furnace is sufficient. Care should be taken, when this is done, to prevent goods being mixed.

A good idea is to divide the storehouse into sections and when a car of iron is received with a certain analysis,

No.	2
GRADE	Hamilton
SILICON	2.42
SULPHUR	.02
PHOSP	.45
MANG	.80
CARB. GRAPH	—
CARB. COMB	—
DATE	4/19/10
CAR No.	72107 87R.

Pig Iron Analysis Card.

put the iron in one of the spaces and tack up a card in a prominent place to show the analysis. A convenient card is shown herewith.

Under "No." is given the space where the iron is placed. The per centages of the various ingredients is also given. It would be advisable to have the sections numbered, the figures being painted in a prominent place to designate the section. Then if, by any means, the card was knocked from its place, anyone could tell where it belonged. Such an arrangement as described would greatly assist the foundry foreman in making up his iron.

NATIONAL IRON WORKS.

The National Iron Works, Cherry St., Toronto, which secured the site on Ashbridge's Bay from the city, held their first "pouring" on Monday, April 4th, at 1.30 p.m., when Cawthra Mulock "poured" the first pipe.

The building is among the best ventilated foundry buildings on the continent. At either end of the building are three immense windows, measuring 25 feet in height and 8 feet in width. It is therefore a well lighted place.

One of the men employed in pouring travels up in mid air on an iron box, which projects out from the side of the "ladle," which carries the molten iron. The big ladle is carried by an immense electric crane up at the top of the building.

The building is made of cement, steel and brick, and is absolutely fireproof. It has an asbestos roof. In the finishing-room, the pipes are taken after they

are removed from the molds to be bathed in tar. The railway sidings to the plant are all completed, the G.T.R. having placed three sidings.

The company already has a large number of contracts on hand, including a large order for 16-inch pipe for Toronto to be used in the Rosedale waterworks, and also a big order from the Consumers' Gas Company. The Toronto Board of Control has also awarded the National Iron Works the contract for Toronto's 1910 requirements of 3, 4 and 6 inch cast iron pipe. It is estimated that twenty miles of 6-in. pipe will be required.

The contracts already booked by the National Iron Works have made it necessary for it to complete arrangements to double up the present capacity of the works. The contracts for the additional construction have already been let.

NEW MILLING CUTTER.

Radical departures from the old styles of face milling cutters are made in the new B. & S. Inserted Tooth Face Milling Cutter just brought out by the Brown & Sharpe Mfg. Co., of Providence, R. I. Means of quick release from the spindle and for interchangeability of the cutters are provided, features never before incorporated in cutters of this design.

These advantages will be readily appreciated by owners of shops as it will do away with the necessity of keeping a large assortment of cutters of various sizes on hand. It will also do away with the time now required to release cutters from the spindle after they have taken heavy cuts.

The cutter, which is keyed to a tapered split sleeve of steel when in position, is made with a taper hole sufficient to cause ready release and that will fit the sleeve which is screwed to the spindle. The cutter is drawn on by

a clamping plate and drawing-bolt which holds it in close proximity to the spindle and allows a maximum amount of working space. By loosening the drawing-in bolt when the work is done the cutter can be easily removed.

In order that a cutter may be used interchangeably on more than one machine special sleeves are provided. These sleeves are made with the outside diameter the same size as the bore of the cutter while the inside of the sleeve will vary to fit the nose of the spindle.

PERSONAL NOTES.

Eugene Stuart Bristol, president of the New Haven Mfg. Co., New Haven, Conn., died on April 2.

H. J. Fuller, president of the Canadian Fairbanks Co., Montreal, is on a trip to the Old Country.

Lawrence L. Anthes, of the Anthes Foundry Co., Toronto, is visiting Western Canada with a view of extending the connections of the company.

Geo. S. Seeber, of the Percival Plow & Stove Co., Merriekville, has resigned his position with that company, and will join his brother, Harry Seeber, in the Canadian Mercantile Agency, Ottawa.

H. H. Hurd, who has been secretary-treasurer of the Ontario Wind Engine and Pump Co., Toronto, for the past nine years, is removing to Winnipeg, where he will have charge of the financial interests of the company in the west. This change of residence has been found necessary owing to the rapid increase of the company's business in the western provinces. At a luncheon tendered him on leaving, Mr. Hurd was presented with a handsome walking stick as a token of esteem in which he was held by his co-directors. The presentation was made by S. H. Chapman, president of the company.

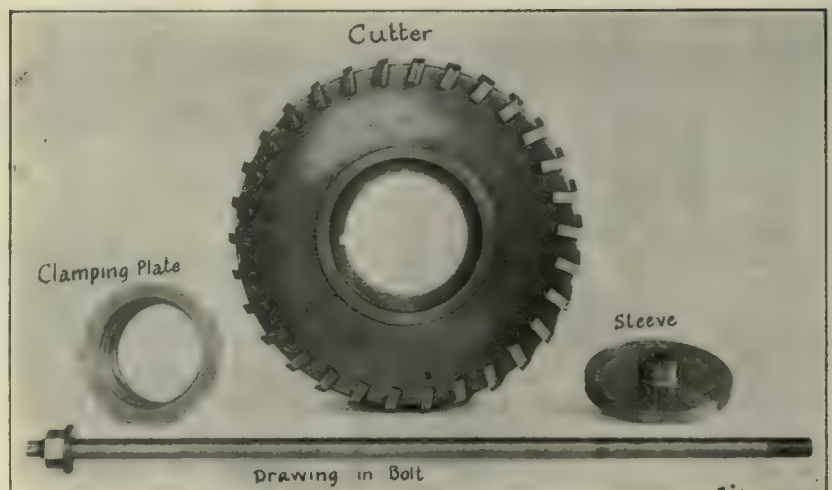

Inserted Face Tooth Milling Cutter, Brown & Sharpe.

INDUSTRIAL AND CONSTRUCTION NEWS

Establishment or Enlargement of Factories, Mills, Power Plants, Etc.; Construction of Railways, Bridges, Etc.; Municipal Undertakings; Mining News.

Foundry and Machine Shop.

The C.P.R. will build a machine shop at Kamloops.

The C.P.R. will erect a machine shop at Yorkton, Sask.

The Scott Machine Co., London, will erect a new plant at London.

The Hamilton City Corporation will build a workshop to cost \$8,500.

Reiffer Bros' brass foundry, St. Catharines, has been destroyed by fire.

Geo. White & Sons, London, will build a plant in East London to cost \$50,000.

The Malleable Iron Works Co. will build an extension to their works at Oshawa.

Reid & Brown's foundry, Toronto, was damaged by fire about the middle of April.

The Dominion Government Mines Branch will establish an ore concentrator at Ottawa.

Gleeson Bros., carriage and wagon manufacturers, will enlarge their works at London.

The Albion Iron Works Co., Vancouver, foundrymen, have advertised their business for sale.

Surgeon Bros' machine works, Qu'Appelle, Sask., were destroyed by fire last month. Loss \$20,000.

Work was started last month on the 160 x 50 factory of the Modern Malleable Range Co., Chatham.

The machine works and garage of Russell Bros., St. Catharines, were destroyed by fire, loss \$2,000.

The William Buck Stove Co., Brantford, has been authorized to increase its capital from \$150,000 to \$1,000,000.

The Atikokan Iron Company's blast furnace at Port Arthur will be placed in commission again as soon as navigation opens.

The Russell Harvester Co., formerly of Woodstock, will in the future be known as the Canada Grain Shocker Co., Hamilton.

The Dominion Radiator Co., Toronto, are planning important extensions of their plant, the details of which have not yet been fully decided.

The Corbett Foundry and Machine Co. will enlarge their present plant at Owen Sound by erecting an up-to-date foundry and machine shop.

The business conducted by the late Andrew Young, at 11 Busby Lane, Montreal, has been purchased and taken over by the Scotia Engineering Works.

A foundry for the manufacture of machinery was granted a loan of \$15,000 by the city of St. Thomas for ten years to enlarge their plant and manufacture furnaces.

Among the extensions to the C. G. E. at Peterboro is an additional machine shop. Property close to the present one has been secured for the purpose.

The National Iron Works, Toronto, who secured the site on Ashbridge's Bay from that city held their first "pouring" on April 4, when Mr. Cawthra Mulock "poured" the first pipe.

The annual convention of the Gurney Foundry Co.'s Ontario traveling salesmen held at the company's King Street offices, Toronto, last month, was attended by about 30 salesmen.

The Canada Bolt & Nut Co., Toronto, have appointed two new agents, for Montreal, Bacon Bros., of Montreal, and for Quebec Province and Ontario east of Belleville, R. B. Coulson, of Montreal.

The contract for the new McCrae gasolene engine factory at Dunville, has been awarded to Albert E. Faulkner, of Brantford. It consists of two buildings, 50 x 136, and 60 x 116. The contract price is \$13,000.

L. H. Warner, of the Perrin Plow & Stove Co., Smith's Falls, has opened up an automobile and motor boat repair shop in Smith's Falls. He is installing a shop equipment of lathes, planer, shaper, drill, etc., for the work.

G. S. Seeber, manager of the Percival Plow and Stove Co., Merrickville, has resigned his position and will leave for Ottawa on June 1, where he will go into partnership with his brother, in the Canadian Mercantile Agency, Ottawa.

Canadian Gas-Power & Launches, Ltd., Toronto, manufacturers of stationary and marine engines and launches, are negotiating to increase their capital with the object of engaging in the manufacture of gasolene traction engines for the western market.

The contract for the erection of the buildings for the Canadian-American Gas and Gasolene Engine Co.'s plant, otherwise the McCrea foundry, at St. Catharines, has been given to Mr. A. E. Faulkner, Brantford. The amount of the contract is about \$12,000.

The Canada Foundry Co., Toronto, recently accomplished a remarkable feat in the way of rapid construction. The eight-story structural steel frame work for the Standard Bank building, Toronto, requiring 475 tons of steel, was erected in 14 days.

The Labatt Manufacturing Company's plant at London, has been taken over by a company of London capitalists. The building, land, and appliances have been purchased for the sum of \$35,000, and the manufacture of all kinds of brass goods will be undertaken.

T. J. Drummond, of Drummond, McCall & Co., Montreal, president of the Lake Superior Corporation, said at a recent meeting of the directors, that the corporation had recently booked an order from the C.P.R. for steel rails aggregating 100,000 tons, with a valuation close to \$3,000,000.

T. Hilliard, sales manager of the Canada Foundry Co., Toronto, has returned from a lengthy trip through the Canadian West with very hopeful views of the outlook, owing to the continued rush of immigration and the great activity in railroad building and public works construction.

The Anhut Motor Car Co., of Detroit has decided to locate at Chatham. The capital of the American concern has been increased from \$150,000 to \$300,000, the stock and premises of the Chatham Motor Car Co. have been purchased, and the concern is in a position to start operations here at once.

The International Harvester Co., Hamilton, have secured a three-year lease of building and equipment subject to ratification of the Paris Plow Co. directors. It is practically a certainty that the directors will give their consent with such a strong company at the head of affairs.

It has been settled that a branch of McLean, Holt & Co.'s foundry business at St. John will be started at Port William. It has been stated that the company would amalgamate with T. McAvity & Sons, but James L. McAvity, proprietor of the former concern and a director of the latter, will neither confirm nor deny the report.

W. C. Hunter, of T. McAvity & Sons', St. John, employ has received a notice from Ottawa that the Hunter & Hatch car heating equipment of which he is the inventor, has been granted a patent for Canada. The equipment was given a test on C.P.R. and I.C.R. trains during the past winter and proved very satisfactory. The heating is done by means of exhaust steam from the engine.

The Scot Engineering Works, Montreal, have recently been acquired by Mr. Thomas O. Sinclair, late of the Hall Engineering Works, and of R. C. White, of the Clyde Iron Works, in succession to the late Andrew Young, at 11 Busby lane. Mr. Sinclair is well-known in the city, having had long experience in the shipping business of Montreal.

Manager Boyd of the International Harvester Co., Hamilton, states that its factory capacity will have to be increased to enable it to keep pace with the demand. The plant is behind in several lines including traction plows and engines, and gasolene traction engines for binding and harvesting operations. Reports from the company's seven distributing houses in the west show large increase in business and indicate that this will be a record year.

Henry Schaake, of the Schaake Machine Works, New Westminster, B.C., has found it necessary to meet the demands of business to incorporate the Schaake Machine Works, of Seattle, with the Western Gas Engine Co., also of Seattle. This will have no effect on the works at New Westminster which have proved a success. Besides Mr. Schaake, the incorporators of the new company are J. C. Johnson, who will be vice-president, and Carl Smith, the secretary-treasurer.

The Belleville Brass Goods Co., Belleville, are changing their name to the Springer Lock Mfg. Co., the reorganized company to be under the managing directorship of W. C. Springer, formerly managing director of the Belleville Hardware Co. A new foundry, 60 x 90 feet and one storey high, is being added to the plant in preparation for taking up the manufacturing of other lines of builders' hardware. About 60 men are now employed, and the number will be added to when the additions are completed.

It is said that the \$30,000,000 merger planned by the Hamilton Steel and Iron Company, and which is planned to include the Canada Bolt and Nut Works with factories in Toronto, Brantford and Gananoque, and the Canada Screw Works, Hamilton, will fall through. It is understood that the charter of one of these companies makes it possible for any stockholder with a hundred shares to block a merger, and this is given as the reason why the Hamilton company is taking such pains to please the minority shareholders.

Plans are being worked out to make the Nelson Iron Works, Ltd., which absorbs the Nelson Iron Works and the Rossland Iron Works, the largest iron industry between Winnipeg and Vancouver. The new company which has been organized has for its officers: President, B. A. Isaacs; vice-president, Leslie Crawford; directors, S. S. Fowler, W. M. Cunliffe, R. W. Hinton. The field of the company will be extensive, including the Boundary, Kootenay and Similkameen districts of British Columbia, the Crow's Nest Pass coal mining district and Western Alberta. Mr. Cunliffe, formerly of the Rossland Iron Works, will be the manager of the company, and Mr. Hinton will continue to be superintendent.

The plans the C.P.R. have in view for improving the local yard at Kamloops, B.C., provide for an expenditure of \$175,000. It is proposed to move the new station back 100 feet from its present position and straighten out the main track. This will enable the company to lay several additional tracks, and thus provide more accommodation for cars. It is expected that this improvement will give space for at least

seven hundred cars, about double the present capacity. A machine shop will be built on the site now occupied by the old coal bunkers, which will be torn down. The shops will be commodious and equipped with modern machinery and give employment to a large staff of machinists. Six of the stalls, constituting the northwest wing of the roundhouse, will be torn down and replaced with larger stalls.

W. M. Cunliffe has sold out his interest in the Rossland Engineering Works, and it is the intention to move the plant to Nelson where it will be merged with that of the Nelson Iron Works. When the amalgamation is completed, a new name may be decided upon for the concern. The Rossland Engineering Works has been in operation here for about eleven years and have employed from ten to twenty men, turning out orders for as far away as the Yukon. It is not lack of business that has prompted the disposal of interests by Mr. Cunliffe, but with the two companies together the management can be more economical. Mr. Cunliffe will take part in the management of the amalgamated companies. The Rossland plant has made a specialty of wrought iron boiler work, and when the two plants are together the works will be as complete as any that can be found east of the coast cities.

George McAvity, president of T. McAvity & Sons, St. John, has recently returned from a visit to a number of United States cities, where in company with Mr. Barlow, superintendent of the foundry business, he was looking over foundries, with a view of getting ideas for the building of an enlarged plant. Mr. Barlow is still away, and is continuing his inspection of plants in various cities with an expert engineer. Before returning to St. John they will probably visit Port Arthur and look over the site that has been offered there. Mr. McAvity states that they must have a site that is accessible by rail and water and the plant which is to be built will employ at the start not less than 500 men and within two years would require from 800 to 1,000 men. A large amount of new machinery has already been ordered and Mr. McAvity says it will be necessary for them to decide very soon where they will locate, as the machinery will be ready for delivery in a short time, and they must know where to have it shipped.

Electrical Notes.

The town of Fergus will have Hydro-Electric power.

The electric light by-law at Waterford, Ont., was carried.

The town of Hanley, Sask., wants an electric lighting system.

Pemberton & Sons will instal a private power plant in the new Pemberton block Victoria.

The by-law at Wetaskawin, Alta., to raise \$5,000 for extension of power plant has been carried.

The by-law to borrow \$122,000 for the purpose of improving the light plant, at Contrecoeur, Que., was carried.

A permit has been issued at Winnipeg for the city power terminal station to be erected at a cost of \$87,000.

The G.T.P. swing bridge at West Fort, over the Kaministiquia river will in the future be operated by electricity.

A new 150 h.p. boiler will be installed in the electric light plant in Fergus, Ont., replacing the smaller boiler now there.

John Houtwig's new \$175,000 sawmill on the south side of False Creek, near Vancouver, will be operated by electricity.

Golden & Lansing contractors, Troy, N. Y., are laying conduits on east Adelaide St., Toronto, to the amount of \$50,000.

The contract for the construction of an addition to the Hull power house was awarded to E. R. Bisson, of Hull, at \$13,386.40.

The Continental Light and Heat Co., Montreal, are making large extensions and improvements to their system in the district of Thetford Mines, Que.

In order to raise money for the development of the water powers at Renfrew a by-law will be submitted to the ratepayers for \$77,000.

The sum of \$25,000 has been placed in the estimates of the Legislature to equip the London Hospital of the Insane with electrical fixtures.

The Brandon Electric Light Co. have applied to the city council for power to instal in the city of Brandon a system to supply heat for public use.

Kingston penitentiary has made an offer to the village of Portsmouth to supply electricity for street lighting, if the latter will erect and maintain poles, wires, lamps, etc.

Tenders for boilers, engines, condenser pumps and piping together with electrical apparatus are called for by Thomas Dunn chairman of electric light committee Prince Rupert up till May 3.

The New Liskeard Light, Heat and Power Co. have issued a writ for \$40,000 damages against the High Falls Mining Co. The plaintiffs claim exclusive right to supply electricity to Halleybury.

The city of Kamloops agrees to take power from the Shuswap Power Co. in accordance with Engineer Dutcher's recommendation. When the matter is finally settled, the company will spend it is estimated, about a million dollars.

The Calgary Power Co. are spending \$1,500,000 in the construction of a dam and plant, which will have a reserve force of water about two miles and between sixty and seventy feet in height and 350 feet broad. The dam is located 40 miles west on the Bow river.

The Crown Electrical Co., St. Charles, Ill., will establish a branch concern at Brantford, to employ 75 hands at the commencement. A building will be erected immediately. The company manufactures electrical and gas fixtures, and have already a good business established in Canada.

The announcement of the incorporation of the International Electric Co., Nelson, capitalized at \$1,000,000, with \$400,000 fully paid up, to develop power from the Pend D'Oreille river from its junction with the Salmon river, is causing much interest. The company proposes to use 4,000 cubic feet per second.

Canadian shareholders of Northern Ohio Traction & Light will be interested in the plans of the company to spend \$1,500,000 on a new power-house, near Akron, Ohio. It will take the place of smaller power-houses at Bedford, Cuyahoga Falls, Akron, Canton and Midvale.

City Engineer Speakman, of Brandon, has prepared plans for the establishment of a steam generating plant, capable of furnishing sufficient power to operate a street railway, the pumping station and street lighting, and have about 300 horse power in reserve. A public steam heating system would also be served. Estimated cost \$125,000.

The West Coast Power Co., Victoria, are making application for a water record of 3,500 feet per second on Gordon river, Vancouver Island, just below the Big Canyon. It is calculated that 110,000 horse power can be developed with this amount of flow and with a 300-foot head. It is stated the works will occupy an area of 100 acres.

The Canadian General Electric Co. will extend its plant at Peterboro and expend \$250,000 in the undertaking. The company will erect a power house at the new waterworks dam, to generate power for their own purposes, and will pay to the city \$2,000 per year. At the end of twenty years the company will hand the plant over to the city without charge.

The Edmonton citizens voted on April 21 on a by-law to issue \$30,000 debentures for the purpose of extending and improving the municipal electric system; also on the same date on a by-law to issue \$60,000 debentures for the purpose of erecting, etc., car barns for the municipal street railway system; also on the same date a by-law to issue \$260,500 debentures to extend and further equip the municipal street railway system.

McCuaig Bros. & Co., Montreal, have purchased the Sherbrooke Street Railway; also water powers in the vicinity. It is the intention to extend the road considerably. A large amount of money will also be expended in developing the power plants.

Municipal Enterprises.

Hamilton's trunk sewer will cost \$476,275.

The proposed sewer at Kingston will cost \$19,000.

A sand filtration plant has been recommended for Brockville, Ont.

The Nassaweya, Ont., ratepayers will vote on a \$10,000 drainage by-law.

Engineers are engaged in preparing plans for the Regina sewerage scheme to cost \$350,000.

G. H. Bryson, acting engineer, of Victoria, in his report on the reservoir states that repairs will cost about \$30,000.

Tenders will shortly be invited for approximately eighty tons of castings required by the waterworks at Vancouver.

Tenders are being called by North Battleford, Sask., for pipes, hydrants, etc., in connection with the waterworks system.

The by-law to raise \$40,000 to complete the waterworks and sewer installation at Wetaskiwin, Alta., has been carried.

The Quebec council is calling for tenders for the annual supply of iron castings, brass castings, lead pipe, pig lead, and drain pipes.

L. H. Buck will submit to the Chilliwack, B.C., council a scheme for a drainage and sewerage system.

The following by-laws were carried at Regina, Sask.: waterworks extensions, \$10,000; sewerage extensions, \$10,000.

The London city council awarded a contract for 2,000 feet of rubber hose to the Mechanical Rubber Co., of Cleveland.

The Township of Etobicoke have awarded the contract for sewers to I. M. Scott, Lambton Mills, Ont., at \$4,727.93.

Tenders have been called for the supply of 137,000 pounds of lead pipe for the Winnipeg waterworks department.

The estimates made by the London Water Commissioners include: Service extension, \$6,000; main extension, \$10,000; meters and hydrants, \$7,500.

The Ontario Railway Board has given Toronto permission to issue \$45,000 debentures to cover the cost of laying trunk sewers in the east and annex.

The by-law to issue debentures to the amount of \$100,000 for extending and improving the waterworks at Hamilton has been passed by the council.

The Winnipeg Board of Control recommends that the contract for supplying water pipe be awarded to the Stanton Iron Works, Montreal, at \$18,131.

The by-law to authorize the issue of debentures to the amount of \$50,000 for the purpose of constructing a system of waterworks at Fort Erie, Ont., was carried.

Prescott, Ont., will shortly invite tenders for the extension of their sewerage system, including one septic tank. A by-law to raise \$22,000 for this purpose has been carried.

The Toronto Board of Control awarded the contract for one 42-inch hydraulically operated stop valve for the main pumping station to Canadian Fairbanks Co., Toronto, at \$1,180.

City Engineer Ker, Ottawa, submitted plans for the west end drainage system with a septic tank in Mechanicsville. The plans will now be forwarded to the provincial board of health for approval.

The St. Thomas power committee awarded the contract for general supplies to Ingram & Davey at \$1,561.44, and The Gartshore Foundry Co., Hamilton, will furnish 30,000 tons of cast iron pipe at \$34 per ton.

Five large water mains will be laid on Trolley, Britannia, Kensington, Cannon and Prospect

Streets, Hamilton, and the services installed as quickly as the people apply for them. The construction of these mains will cost about \$19,000.

The Aylmer, Ont., Water Commissioners have purchased land for a reservoir and work will be commenced at once on a pipe line. It is estimated that this will give the town from three to five hundred thousand gallons more water a day, at an initial cost of \$12,000.

The contract for the manufacture of reinforced concrete tile for storm sewers on Brant Avenue, Waterloo Street, and Albion Street, Brantford, has been awarded to the Lock Joint Pipe Co., New York, on the condition that the pipe be manufactured here, and local labor employed.

The Winnipeg city engineer reports that the estimated cost of a sewer in Godfrey Avenue, from Cambridge Street to the city limits, was \$23,563; that of a main sewer in Ash Street, from Assiniboine river to Godfrey Street, is \$38,225; and a main sewer in Crescent Road, from Ash to Renfrew, will cost \$49,772. The cost of the sewer in Renfrew, from Crescent Road to Godfrey, is placed at \$10,263, making a total of \$121,823.

The Kingston Waterworks Committee recommend that tenders for supplies be awarded as follows: Selby & Youlden, hydrants, etc.; Francis Tracy, steel drills, picks, etc.; Chadwick Bros., service cocks; Canada Foundry Co., valve, etc.; Gartshore, Thompson Pipe & Foundry Co., cast iron piping; Queen City Oil Co., oil; Simons Bros., block tin, waste, etc.; W. B. Dalton & Sons, fire clay, shovels, etc.; McKelvey & Birch, lead piping, galvanized piping, fittings, etc.

The following tenders for water works supplies for 1910 were recommended for acceptance by the Calgary council: Canadian Brass Co., Galt, brass work for house services, \$2,357. J. Robertson Co., Winnipeg, pipe lead, \$5.50 per 100 lbs., pig lead, \$4.62 per 100 lbs. Gurney Standard Metal Co., oakum, \$3.75 per 100 lbs. Crane & Ordway, Calgary, galvanized iron pipe, \$3,175. Calgary Ironworks, Calgary, valve boxes, \$4 per 100 lbs., and hydrants, \$50 all sizes without crane attachment. Canadian Foundry Co., Toronto, crane posts, \$54.10; specials, \$3.20 per 100 lbs. Bissett & Loucks, Winnipeg, valves, \$2,989.30. Union Iron Works, Calgary, hydrants, 8 ft., \$49.50; 8 ft. 6 in., \$50; 9 ft., \$51.50 without crane attachment, with crane attachment \$5 extra. Evans, Coleman, Evans, Vancouver, cast iron pipe.

Structural Steel.

The highway bridge at Fredericton is completed. The total cost was about \$285,000.

The Brantford city engineer will ask for tenders for a new concrete, steel reinforced bridge over Market Street, approximate cost, \$50,000.

The Hamilton Bridge Works have been awarded the contract for the structural steel work on the Sawyer-Massey Company's new building, at Hamilton.

The corporation of St. Johns have bought a steel vehicular bridge from the city of Pittsburgh, Pa. The bridge will span the river between St. Johns and Iberville. The bridge was bought at one and one-tenth cents per lb. The total cost delivered in St. Johns will be about \$8,500.

The presentation of plans for the proposed new bridges over the Great Northern Railway cut at Victoria and Park drives, Vancouver, are under consideration and call for 30 and 42 foot width respectively, with 26 foot walks on each. Both bridges will be of steel of the deck design and will cost approximately \$18,000 to \$20,000.

Planing Mill News.

O. H. Moxley is building a new mill at New Liskeard, Ont.

Dickenson & Scott are erecting a sash and door factory at North Vancouver.

Culliton Bros. are erecting a new sawmill at Loon Lake, near Albernie, B.C.

The Chicoutimi Pulp Company's new mills at Chicoutimi, Que., are completed.

The Cleveland-Sarnia Saw Mills Co., Sarnia, will build a planing mill to their plant at that place.

J. Kaufman, Berlin, Ont., will erect an addition to his planing mill. Estimated cost about \$14,000.

John Hanbury, of Brandon, will erect a lumber mill on the south side of Falls Creek, B.C. to cost \$175,000.

The Toplin Timber Co., of Toronto, are erecting a saw-mill on the shore of Lake Sasquiaga, near Cobalt.

Jas. McDiarmid & Co. have been awarded the contract to construct the planing mill at the C.P.R. shops at Winnipeg.

Leslie Bros' planing mill at Mount Forest, was completely gutted by fire. The mill was partly covered by insurance.

Galbraith & Airth, Chatsworth, Ont., will move their sawmill and sash and door factory to Owen Sound in the near future.

The Watt Milling & Feed Co., of Toronto and Shelburne have now a complete planing mill and sash and door factory in Shelburne. The building was overhauled and enlarged last fall and a number of new up-to-date machines installed.

Engines, Generators and Boilers

FOR SALE IN GOOD ORDER AND CONDITION.

Boilers.

- 1 Robb-Mumford boiler rated at 150 h.p.; working pressure 125 lbs. per square inch; heating surface 1220 sq. ft.; grate surface 24½ sq. ft.; built 1898. Some tubes require renewal.
- 1 Cornish boiler, built by the John McDougall Co.; working pressure 80 lbs. per square inch; heating surface 224 sq. ft.; grate surface 8½ sq. ft.

Engines and Generators.

- 2 75 kilowatt direct connected engines and generators. Each engine has a cylinder 12" diameter x 14" stroke, suitable for 120 lbs. working pressure. Each generator is of 600 amperes capacity at 115 to 150 volts direct current, and runs at 270 revolutions per minute. Unit No. 1 consists of a Robb engine connected to a Crocker-Wheeler generator. Set No. 2 consists of an Ideal engine connected to a Canadian General Electric Generator.

These sets are both 9 years old. They can be seen running at any time by appointment.

The machinery is offered for sale as it stands in the Macdonald Engineering Building, McGill University, Montreal, and purchaser must undertake removal.

W. VAUGHAN,
Bursar, McGill University.

Editor Wanted

High-grade Editorial Man wanted for this journal. Must be graduate in mechanical engineering and with some experience in shop management.

Applications will be treated in strictest confidence.

Canadian Machinery
10 FRONT STREET EAST
TORONTO



Canadian Hart Wheels

442 Barton St. East, Hamilton

Corundum and Emery Wheels
Grinding Machines, Beaver
Oil Stones.

OPAL GLASS TILING

FOR WALLS OF

MACHINERY AND POWER HOUSES

Most approved material.

TORONTO PLATE GLASS IMPORTING CO'Y

PLATE AND WINDOW GLASS

135 to 143 Victoria St., - Toronto

YOUNG machinist or technical graduate wanted to travel. Must be good talker and resourceful. No previous traveling experience necessary. Splendid opportunity for ambitious man to work into a good position. Apply

BOX 101
Canadian Machinery
Toronto

BETTER RESULTS AT LOWER COST

can be secured for any class of castings by arranging your mixtures by analysis. Years of practical experience in foundry work are at your service when you consult with

The Toronto Testing Laboratory, Limited

18 SATURDAY NIGHT BUILDING, TORONTO

EXPERT FOUNDRYMEN, METALLURGISTS, CHEMISTS

TESTS OF METALS, FUELS, CORES, OILS, Etc., AT REASONABLE PRICES.

BRASS CASTINGS

OF ALL SIZES AND KINDS

LUMEN BEARING COMPANY
BUFFALO TORONTO

BENCH POWER PRESS



New Design

Particularly adapted for small, quick work, to take place of foot presses.

Write for Prices.

W. H. Banfield & Sons

MACHINISTS, DIE AND TOOL MAKERS
120 Adelaide Street West
TORONTO - - - CANADA

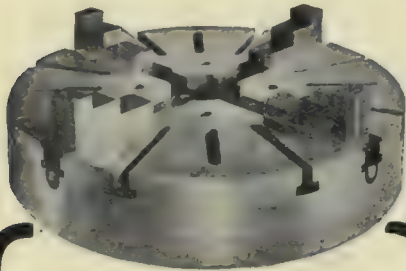

A FREE TRIAL FOR 30 DAYS

Will you let us send you an
IMPERIAL CHUCK

on 30 days' free trial, just to enable you to prove how good it really is? We know of no test too severe for the "Imperial," and we ask you to use it in your shop and test it any way you can think of. If it won't answer every demand made upon it, send it back at our expense!

Send for catalogue.

Ker & Goodwin

Brantford, Canada

The property of the Fraser River Lumber Co., New Westminster, B.C., has been acquired by the Canadian Western Lumber Co. The Fraser River Co. is said to be the largest in the world. The amount involved in the sale is almost \$20,000,000.

Atkins & Hardy are the movers in a new industrial concern, which will be established at Owen Sound. They were in Toronto last week, and purchased machinery for the manufacture of wood fibre. And have let the contracts for the erection of a concrete building, 40 x 60 feet.

John Pierson's heading box and planing mill factory at Stevensville, Ont., was destroyed by fire, with the contents, machinery and manufactured lumber and the lumber piled nearby. A lot of new machinery was lately put in. Loss about nine thousand dollars, without any insurance.

General Manufacturing News.

Hon. Adam Beck will build a box factory at Winnipeg.

The Canada Cement Co. will erect a cement mill at Winnipeg.

The N. C. Polson Co. will erect a factory and warehouse at Kingston.

The Knechtel Furniture Co. will erect a new factory at Hanover, Ont.

F. C. Durant will erect a sugar refinery at St. John to cost about \$2,000,000.

The Canada Loose Leaf Co. will erect an addition to their factory at Montreal.

The Brantford Cordage Co. will make extensions to their factory at Brantford.

The Coleman Baking Co., Toronto, will build a bakery at Winnipeg, to cost \$50,000.

The Cockshutt Plow Co. will make large extensions to their plant at Brantford.

The Plymouth Cordage Co., Welland, will erect a 300 foot addition to their storage and warehouse facilities.

Work has been commenced on the new building for the Kingston Shipbuilding Co., Kingston. It will be 125 x 62 feet, two storeys high.

The Shurly & Dietrich Co., Galt, will erect an addition 100 x 45 feet, of reinforced concrete with fire-proof roof, for storage purposes.

W. C. Cuthbert Ward, of the firm of J. H. Andrew & Co., Toledo Steel Works, Sheffield, Eng., is in Canada in the interests of his firm.

The Stone, Limited, have been granted a permit to erect an addition to their factory at 461 King Street West, Toronto, at a cost of \$35,000.

The Allan Hills Edge Tool Co., Galt, is now employing 40 hands, after four months' operation. The demand for their products is steadily increasing.

The Canadian Slate Products Co., capitalized at \$2,500,000, will commence the erection and installation of their plant at Vermilion, Alta. in the near future. Estimated cost about \$1,000,000.

The Empire Refining Co., Wallaceburg, announce that building operations will be started at once on a \$26,000 addition to the refinery which will be utilized for the manufacture of candles and wax in all its forms.

The St. Catharines ratepayers voted on by-laws to grant exemption to the Canadian Crocker-Wheeler Co., Monarch Knitting Co. and the St. Catharines Woollen Mills Co., on April 22 all three being carried by large majorities.

A new industry is about to be established in the city of Quebec, when the Crown Rubber Shoe Company will start operations in the new ward of Limoilou. The factory will employ 200 people and will produce an average of 2,000 pairs of rubbers daily.

The St. Thomas, Ont., by-law to loan \$10,000 to the C. Norsworthy Co. for ten years without interest to enable them to go into the manufacture of furnaces, stoves, etc., has been carried. The by-law to loan \$15,000 to the Nursery Shoe Co., Toronto, for ten years, with three years' interest was also carried.

Fire broke out in "B" elevator of the Calgary Milling Co., Calgary. The cause was spontaneous combustion. One hundred thousand

bushels of grain were burned. The total loss in grain and building was \$300,000. The insurance is light. The elevator had a capacity of 250,000 bushels, and was erected in 1905.

The Onward Manufacturing Co., Berlin, announce that they intend erecting an addition to their factory, as the present building is inadequate for the manufacture of their sliding furniture shoes. Their vacuum cleaner business is also growing rapidly, as hardware dealers have found their sale a profitable side line.

It is announced that a deal has been effected whereby Chatham Bent Goods Co., Chatham, which has been idle since last fall, will resume operations. The plant and premises have been acquired by Merritt & Co. There is also talk of a new bent goods factory being started by some of the men formerly connected with the old concern.

The agreement between the city of St. John and the David Craig Co., Boston, whereby the Craig concern secures a lease of property at Green Head, for establishing a plant for the manufacture of concrete blocks for building purposes, was signed last week and the work of getting the buildings and machinery in place will commence on May 1.

The Hanbury Mfg. Co., whose head office is at Winnipeg, announce that they will at once double the capacity of their whole establishment, factories, mills, warehouses and offices, which will result in hundreds of extra hands being employed and thousands of dollars worth of new machinery being installed. The company expects to have these improvements completed by June 1.

The B. F. Nelson Co., manufacturers of roofing and building material, Minneapolis, are about to open several branch offices in the west where complete stocks are to be stored. In the near future a plant is to be erected somewhere in the west for the manufacture of their materials. The Canadian business of the company is to be in charge of F. P. Barker, formerly of the American Roofing Co., Kansas City.

Building Operations.

Calgary Odd Fellows will erect a \$100,000 temple.

The Grey Nuns will a new building at Regina, Sask.

A \$12,000 school house will be erected at Elbow, Sask.

Douglas & Co. will erect a warehouse at Winnipeg.

A new Anglican church will be erected at Merritt, B.C.

The new Orpheum theatre at Winnipeg will cost \$150,000.

The new Y.M.C.A. building at Winnipeg will cost \$300,000.

L. Christie will erect a \$10,000 block at Fort Frances, Ont.

Finch & Finch will erect a three-storey block at Victoria, B.C.

J. Vaio will build a business block at Victoria to cost \$10,000.

A new isolation hospital will be erected at Vancouver, B.C.

W. Holden is erecting a \$250,000 building at Vancouver, B.C.

The new building for the Y.M.C.A. at Halifax, will cost \$150,000.

The McClary Mfg. Co. will erect a new warehouse at Calgary.

Willis & Co., Montreal, will erect a new building at that place.

R. Howson & Co. will erect a business block at Revelstoke, B.C.

The Tourist Hotel Co. will erect a new building at Kenora, Ont.

An apartment block will be erected at Winnipeg to cost \$350,000.

The Union Bank will erect a \$150,000 office building at Toronto.

The Canada Veiling Co. are erecting a \$76,000 building at Toronto.

Mr. Moriarty, of Spokane, will build a business block at Calgary.

Amos Shulk will erect a \$20,000 apartment house at Toronto.

An Anglican church will be erected at Lethbridge to cost \$100,000.

S. Hinacal will erect a cold storage plant at Winnipeg, to cost \$80,000.

The First Methodist congregation will erect a new church at Hamilton.

A new municipal building will be erected at Sudbury to cost \$25,000.

An annex will be erected to the Montreal City Hall at a cost of \$175,000.

H. A. Sinnot, Calgary, will build a large business block at Lethbridge.

An annex will be built to the Brunswick hotel, Winnipeg, to cost \$22,000.

J. A. Seabold will build a business block at Vancouver to cost \$78,000.

An English syndicate will build a warehouse at Winnipeg to cost \$100,000.

Sweeney & McConnell will erect a building at Victoria to cost \$15,000.

A. B. Kent will erect an apartment house at Winnipeg to cost \$50,000.

The Bank of Montreal will erect a building at Winnipeg to cost \$950,000.

A new school house is being erected at Westboro, Ont., to cost \$15,000.

The G.T.P. will erect a 10,000,000 bushel elevator at Port Arthur, Ont.

Stanfields, Ltd., will erect a large building at Truro, N.S., to cost \$50,000.

MacMillan & Vollans will build an \$80,000 apartment house at Winnipeg.

The Royal Canadian Flour Mills Co. will erect a large plant at Kenora, Ont.

An armory will be built next year at Prince Albert, Sask., to cost \$10,000.

Senator Loughheed will erect a skyscraper, at Calgary, at a cost of \$300,000.

Gowans Kent Western, Ltd., will erect a 6-storey warehouse at Winnipeg.

C. F. Madden will erect a \$35,000 apartment house on St. Albans St., Toronto.

A new Catholic church will be erected at Verdun, Que., to cost over \$100,000.

F. Lindsay will erect a store and apartment block at Winnipeg to cost \$90,000.

The Bank of Toronto will erect a branch at Yonge and Charles Streets, Toronto.

The Rogers Fruit Co. will build a distribution warehouse at Portage la Prairie, Man.

The B.C. Government will erect a new hospital at New Westminster to cost \$75,000.

The new Metallurgy building for the School of Mining at Kingston, will cost \$40,000.

The Bell Telephone Co. will erect a new office building at Stratford to cost \$50,000.

The Prince of Wales Fusiliers, Montreal, will have a new armory erected for them.

The Henderson Mfg. Co., Winnipeg, will erect a large block at that place to cost \$35,000.

A rink of steel structure will be erected at Carleton Place, Ont., to cost about \$15,000.

C. H. Stephenson, Saskatoon, will erect a business block at that place to cost \$20,000.

Central Congregational Church, Winnipeg, will build an edifice to accommodate 4,000 people.

The congregation of St. Stephen's Church, Toronto, will erect a new edifice to cost \$60,000.

The Fort Rouge Methodist congregation, Winnipeg, will erect a new edifice to cost \$45,000.

The Young Methodist Church congregation will erect a new edifice at Winnipeg to cost \$72,000.

H. A. Hart has been granted a permit to build an apartment house at Toronto, to cost \$25,000.

A large building is being erected on Donald Street, Winnipeg, for the Canada Cycle & Motor Co.

The Hobbs Hardware Co. are erecting a large building at London north of their present factory.

Carson, Falkner & Ladell will erect a block of stores and apartments at Winnipeg to cost \$25,000.

The High Park Methodist Church, Toronto, will build a Sunday school building to cost \$20,000.

The High Park Methodist Church, Toronto, will build a Sunday school building to cost \$20,000.

**MALLEABLE IRON
CASTINGS**

**PRATT & LETCHWORTH CO.
BRANTFORD ONTARIO**

ALUMINIUM

"The 20th Century Metal"

You can now get your Aluminium requirements promptly attended to by our clients, The British Aluminium Co., Limited, of London, the largest producers in the United Kingdom.

Lightest and most adaptable of the industrial metals. Fills a hundred purposes where the ordinary metals fail. Saves its cost over and over again by its lightness and easy working qualities.

Sole Agents for Canada: Parke & Leith, 205 Yonge Street (Bank of Toronto Building) - - - Toronto.

To-day get Bulletin "D" on the varied uses of ALUMINIUM (Parke & Leith)

JESSOP'S BEST TOOL STEEL

"ARK" High-Speed Steel

THE FAVORITE BRANDS WITH USERS OF GOOD STEEL.
A LARGE ASSORTMENT OF SIZES IN STOCK.
JESSOP'S HIGH-GRADE FILES AND RASPS.

80 Bay, St., Toronto, Ontario
Chas. L. Bailey, Agent.

Reid-Newfoundland Company
St. John's, Newfoundland.

Jas. Robertson Co., Ltd.
Montreal, Quebec

Jas. Robertson Co., Ltd.,
St. John, New Brunswick

WM. JESSOP & SONS, Limited, Manufactory, SHEFFIELD, ENGLAND.

We want your orders for

SPECIAL TAPS

Price, delivery, and quality
will please you.

A. B. Jardine & Co., Hespeler, Ont

THE BEYER WATCHMAN'S PORTABLE CLOCK



IS TAMPER PROOF
and thoroughly reliable

Shall we send
Particulars?

G. C. BREDIN, Sales Agent
252 Dundas St. London, Canada
Record Dials furnished for all machines.

Do Your Tumbling

in a Globe improved Tilting Tumbler and get finest results, quickest and cheapest. It is made in six sizes for all purposes for wet or dry work.



"GLOBE"

Dies and Stampings.
Special Manufacturing
Contract Work.

If you want to get an interesting little magazine free, ask for "THE SILVER PARTNER."

THE GLOBE MACHINE & STAMPING CO.

599 Hamilton Street, Cleveland, O.

Canadian Agent:

H. W. PETRIE, Front St. W., Toronto, Canada

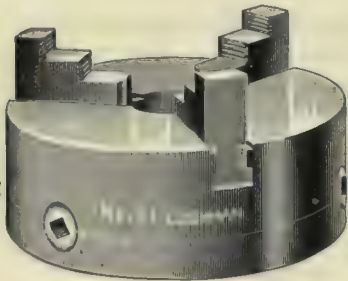

"CUSHMAN" CHUCKS

For general machinists' use.
Strong and durable and
designed for hard service.

Our catalogue shows many
styles and sizes and is sent
free.

The Cushman Chuck Co.

Hartford, Conn., U.S.A.

Established 1892



The Port Arthur Independent Order of Foresters are planning to erect a business block at that place.

Judge Travis, Beveridge Bros. and Geo. Bryan will erect a five storey block at Calgary, to cost \$25,000.

The congregation of the First Baptist Church, Vancouver, B.C., will erect a new edifice to cost \$100,000.

The Home Investment Co., Vancouver, were granted a permit to build a five storey block to cost \$75,000.

The C.P.R. will double the capacity of its hard coal storage warehouse, Fort William, at a cost of \$200,000.

The Canada Life Assurance Co. will erect a large eight-storey office building at Vancouver, costing \$20,000.

Burns & Walker, have purchased property at North Vancouver, B.C., on which a tourist hotel will be erected.

The Eldrans-Brandon Pressed Brick Co. will make extensive additions to their plant at Eldrans, Man.

A new palm house and conservatory will be erected in Stanley Park, Vancouver, as an Oppenheimer memorial.

The Dominion Stock & Bond Corporation of Vancouver, will erect a 12-storey building at that place to cost \$600,000.

A chain of Carlton-Ritz hotels will be erected in Canada. The first will be built at Montreal to cost about \$3,000,000.

Swift & Co., Stratford, have awarded the contract for the construction of their storage plant to John L. Youngs.

W. Bruce, Winnipeg, is preparing plans for an apartment house to be erected by the Minnawaska Syndicate at Winnipeg.

The Thistle Curling Club and the members of the Builders' Exchange have decided to build a large curling plant at Winnipeg.

Plans are under preparation for a church for the congregation of the First Church of Christ, Scientist, Winnipeg, to cost \$75,000.

The contract for the Canada Permanent company's new \$65,000 office building at Edmonton has been awarded to Peasey & Batson.

Improvements and extensions to cost \$15,000 will be made to the Rosedale stand and club house by the Toronto Lacrosse & Athletic Association.

Two new collegiate institutes will be erected at Winnipeg, one in the north and the other in the south. Each building will cost in the neighborhood of \$225,000.

William Bruce, Winnipeg, is preparing plans for an apartment house to be erected there this spring, to cost \$50,000, and also for a \$50,000 residence for R. J. McKenzie.

Winnipeg proposes to spend on the extension of General hospital, \$300,000; auxiliary hospital to General \$100,000; isolation hospital, \$100,000; tubercular hospital, \$75,000; and morgue, \$25,000.

The Metropolitan Building Co., Wm. Holden George J. Bauer, are erecting ten-storey steel-concrete buildings at Vancouver, and George Bower is also erecting an eight-storey building of the same type in that city.

The following buildings will be erected at Winnipeg; Warehouse and additions to Western Flour Mills, \$260,000; warehouse for Berna Taxicab Co., \$40,000; business block for R. R. Pattinson, \$70,000; pavilion and garage for automobile club at Stonewall, \$25,000; store and apartment block for A. C. Gardiner, \$58,000.

New Companies.

The Rodney Woodenware Co., Rodney, have obtained a charter.

The Brown-Jarvis Roofing Co., Brantford, have obtained a charter.

A charter has been granted to the United Counties Oil & Gas Co., Pendleton.

The Robinson Glue So., Montreal; capital, \$75,000, to manufacture, import and sell glues, etc. Incorporators, J. G. deLorimier, G. W. Dow and A. H. Brittain, Montreal.

SPECIAL MACHINERY, Etc.

ARMSTRONG BROS.

18 Sheppard St., Toronto
Mfrs. of SPECIAL MACHINERY
Patents Perfected
GEAR CUTTING, TOOLS, DIES, ETC.
Ruching and Pleating Machinery.

ERNEST SCOTT

91 BLEURY ST., - MONTREAL
Machinist and Tool-maker
Dies for sheet metal work. Stampings and light manufacturing. Special machinery designed and made to order.

The PARMENTER BULLOCH CO., Ltd. GANANOQUE, ONT.

Iron and Copper Rivets, Iron and Copper Burrs, Bifurcated and Tubular Rivets, Wire Nails, Copper and Steel Boat and Canoe Nails, Escutcheon Pins, Leather Shoe and Overshoe Buckles, Felloe Plates.

OWEN SOUND IRON WORKS, LIMITED OWEN SOUND, ONT.

Cement Mill Machinery, Boiler and Steel Tank Work of all kinds, Grey Iron and Brass Castings

PATTERNS AND MODELS

PATTERNS IN WOOD

~ ALL KINDS ~

Difficult Core Work a Specialty
High Grade - Right Prices - Prompt Delivery
SATISFACTORY WORK GUARANTEED

THE HAMILTON PATTERN WORKS
258 CATHERINE STREET NORTH
HAMILTON, ONT.

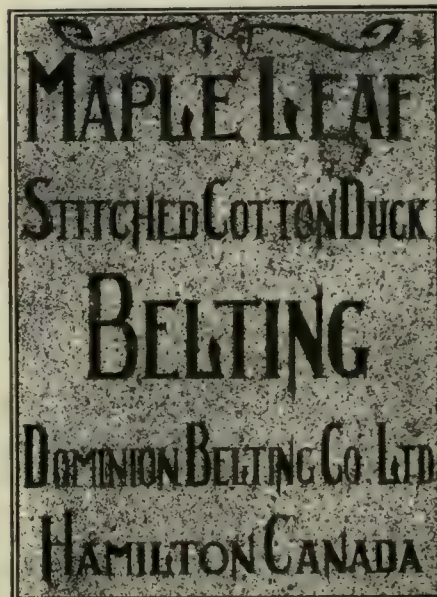

Monmouth Granite Quarries, Toronto; capital, \$50,000; to quarry, manufacture and sell granite and stone of all kinds. Incorporators, E. Berridge, J. P. Berridge, H. R. Sharpe, Toronto.

Kirvan-Doig, Montreal; capital, \$50,000; to manufacture and deal in boots, shoes, rubbers, blacking and varnish. Incorporators, E. Langueudoc, E. S. Parkins and O. Cagnon, Montreal.

Scythes & Co., Toronto; capital, \$75,000; to manufacture and deal in threads, twine, hemp, cotton, flax, rubber clothing and belting of rubber. Incorporators, J. A. Scythes, G. N. Dale, J. G. Taylor, Toronto.

Frank Lime Co., Toronto; capital, \$50,000; to manufacture and deal in cement, limestone, calcined and other plasters, artificial stone and sewer pipe. Incorporators, O. M. Moore, J. McBain, J. Faust, Toronto.

Edwards, Reesor Co., Toronto, capital \$40,000; to manufacture, instal and deal in furnaces, boilers, sheet metal work, machine work, tools, plumbing, etc. Incorporators are A. B. Reesor, G. E. Edwards, F. W. Hider, of Toronto.

The Colombia Oil and Gas Co., Ottawa; capital, \$4,000,000, to prospect, manufacture and refine oil wells and products. Incorporators, J. H. Spence, M. C. Cameron and D. D. McLeod, Toronto.

Knight Bros. & M'Kinnon, Cobalt; capital, \$50,000; to manufacture, buy and deal in shingles, hardware and mining supplies. Incorporators, H. Knight, W. Sharpe, H. L. Barber, Burk's Falls, Ont.

The Canadian Glass Co., Hamilton; capital, \$100,000; to manufacture and carry on a business in glass in every description. Incorporators, M. J. O'Reilly, G. H. Levy and W. W. Osborne, Hamilton.

Anchor Packing Co., of Canada, Walkerville, Ont.; capital, \$40,000; to manufacture and deal in rubber goods and goods of rubber compounds. Incorporators, E. C. Adams, O. M. Flynn, F. A. Kohl, Detroit, Mich.

W. G. Colville Co., Fort William; capital, \$40,000; to manufacture, buy and deal in hardware, metals, paints and sporting, and household supplies. Incorporators, W. G. Colville, J. A. Fife, A. H. Dowler, Fort William.

Canadian Mahogany Co., Ottawa; capital, \$200,000; to manufacture and deal in timber, wood and woodenware of all kinds. Incorporators, Hon. W. C. Edwards and G. C. Edward, both of Ottawa, W. A. Hall, New York.

The Ozone Purified Water, Montreal; capital, \$100,000; to manufacture bottles and stoppers, to instal plants, machineries, apparatus or any other requirements for the purification of water. Incorporators, R. Duckett, J. P. Lamarche and G. Allard, Montreal.

Dominion Dry Dock Co., Quebec; capital \$1,000,000; to carry on the business of shipbuilding and ship repairing, to design, construct or take down dry docks, wet docks, harbors, slips, piers and wharves, work shops, buildings, machinery and warehouses. Incorporators, Sir Thomas Shaughnessy, H. A. Allen, Montreal, G. D. Davie, Quebec.

Trade Notes.

The Philip Carey Mfg. Co., manufacturers of insulating materials have moved their Toronto offices from 112 Bay St. to 77 Front St. East.

The General Supply Co., Ottawa, have removed their office and warerooms to 356-358 and 360 Sparks St., where they will have more commodious quarters.

The Sclater Asbestos Co., Montreal, will move about May 1st from their old offices, 102 Nazareth St., to new quarters at the corner of Brennan and Dalhousie Streets.

The Cleveland Twist Drill Co. will move their Chicago branch to 9 North Jefferson St. In their new location greatly improved facilities for the prompt handling of their steadily increasing business are afforded.

The Magnolia Metal Co., 113-115 Bank St., New York, are erecting new offices and factory at 223 St. Ambrose St., Montreal. The factory has been specially designed for their require-

ments and they expect to occupy it by May 1st.

The Canadian Laboratories, of which W. K. McNeill, B.Sc., is manager, have removed their offices from 37 Melinda St., to 24 Adelaide St., West, Toronto. Ores, fuels, alloys, cements, pig iron, steel and other commercial products are tested and analyzed by this company.

The following tenders for supplies of cast-iron pipe have been accepted by the Toronto Board of Control: National Iron Works, 3-inch pipe, \$4.35 per length; 4-inch pipe, \$4.88 per length; 6-inch pipe, \$6.97 per length. Canada Foundry Co., 8-inch pipe, \$10.50 per length; 10-inch pipe, \$14.80 per length; 12-inch pipe, \$19.85 per length.

R. A. Brown, for the past sixteen years associated with the Joseph Dixon Crucible Co., at Jersey City, known throughout the world as the "Oriental Man," has severed his connection with that house, and is now associated with the Jonathan Bartley Crucible Co., of Trenton, New Jersey. At the present time, Mr. Brown is on his way to South Africa, and will make an extended trip covering all parts of the globe.

Smart-Turner Machine Co., 191 Barton St. E., Hamilton, report the following recent orders for pumps: Doolittle & Wilcox, Dundas; Millers Tanning & Extract Co., Millerton, N.B.; Contracts, Ltd., Bracebridge; Algoma Lumber & Chemical Co., Parry Sound; Edwin Crabtree & Sons, Crabtree Mills, P.Q.; I.C.R., Moncton, N.B.; Kent School, Toronto; Blangas Co., Montreal; Slingsby Mfg. Co., Brantford; Great Lakes Dredging Co., Port Arthur; Keenan Woodenware Mfg. Co., Owen Sound; and Waines & Root Gas Co., Dunnville, Ont.

The Canada Forge Co., Welland, are remodeling their steel heating plant and have placed a contract with the Standard Engineering Co., Toronto, for the new furnaces, which will be equipped with type M American mechanical stokers burning slack coal. Another contract recently placed with the Standard Engineering Co., is a steel heating furnace for the Superior Steel Co., Toronto. This latter is equipped with a No. 5 type R American mechanical stoker. The furnace will be used in connection with the new process of making steel direct from iron.

The Simonds Mfg. Co., of Fitchburg, Chicago and Montreal, make announcement of the completion of plans for the erection of a new steel mill at Lockport, N.Y., that will at once double the capacity of their Chicago mill and before long increase the first Lockport output. The contracts call for completion of the building and installation of machinery so that production will begin by October 1. The initial investment will be fully a quarter of a million dollars. In addition to the three plants and the new steel mill, the Simonds Mfg. Co. has branch houses at New York, Portland, Ore., Seattle, Wash., New Orleans, San Francisco, Vancouver, B.C., St. John, N.B., and London, England.

The Welland Canal.

The Toronto branch of the Canadian Manufacturers' Association and the Council of the Board of Trade passed resolutions on April 14 urging the deepening and improvement of the Welland Canal. Copies of the resolutions will be forwarded to Sir Wilfrid Laurier and members of the Ottawa Government.

C. N. R. Shops for Toronto.

D. D. Mann, vice-pres. C.N.R., says that the C.N.R. shops will be built in Toronto. A request has been sent to the Toronto city council for a fourteen foot right-of-way on the east bank of the Don River, but no definite action has been taken by the council.

Two Thousand Steel Box Cars.

The C.P.R. has just placed with the Dominion Car and Foundry Company the second million-dollar order this year for a thousand steel frame 80,000-lb. box cars. The cars covered by the order placed at the beginning of the year are being turned out at the rate of 15 per day, representing a cost of about a thousand dollars apiece.

Side Head of the Vertical Turret Lathe

A Big Factor in Reducing the Cost of Production of Many Kinds of Face Plate Work.

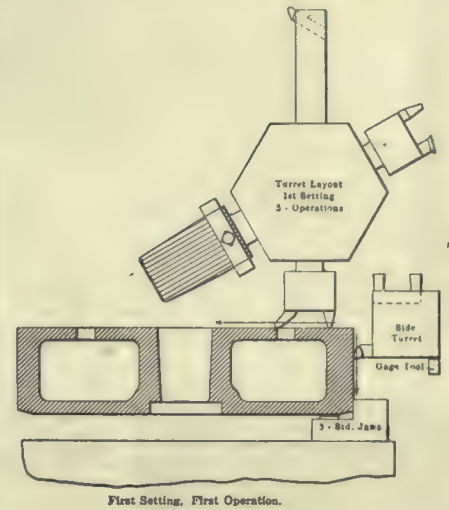

Perhaps the greatest productive difference between modern and pre-modern machine tools is the doubling up or "tripling" up of cutting tools. One cut at a time is no longer sufficient to get competition-meeting results, and it was the realization of this fact that led to the designing of the Bullard Vertical Turret Lathe.

Besides the main turret head this machine has a side head which enables the operator to take simultaneous cuts on various surfaces. It does not interfere in any way with the operation of the main head.

The illustration herewith shows a job on which the Vertical Turret Lathe made a new record of 90 min.

The piece is a 27½ in. piston on which simultaneous cuts with the Side Head cut 30 minutes from the best previous time.

The Vertical Turret Lathe has two heads—a turret head and a side head—which allow two or more tools to be used at the same time.

All the tools needed for a whole series of operations are held in instant readiness.

In a word the Vertical Turret Lathe is a unique combination of the good points, the advantages of the vertical boring mill and the horizontal turret lathe.

Its vertical construction allows many a piece to be finished before it could be chucked ready for work on a horizontal turret lathe. For modern work—especially for duplicate pieces—the Bullard Vertical Turret Lathe is an innovation. It is a tool you must know about.

The entire sequence of operations on the piece shown here and other pieces is graphically illustrated in our new catalog, which is free for the asking. Send for catalog C-15.

The Bullard Machine Tool Co.
Bridgeport, Conn., U.S.A.

60 Days'

An accident may happen any day in your shop, but often enough the damage done may be minimised by the prompt application of suitable remedies.



FREE TRIAL!

Alike from the humane and the economic standpoint, the employer of labor serves his own interests best if he keeps handy a stock of remedies for any emergency.

The Factory Emergency Cabinet

is designed to meet every requirement in rendering first aid, and to introduce it into every shop in Canada we will send it on 60 days' free trial. If at the end of that time you find you can do without it—send it back at our cost. If not, send the price, \$9.50, f.o.b. TORONTO, duty paid. Write us to-day.

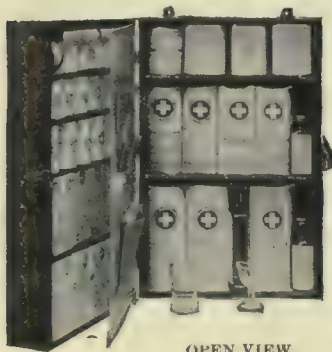

OPEN VIEW
Size, 23 x 18 x 3 1/4

The
Accident
Cabinet Co.

Kalamazoo,
Mich., U.S.A.



OPEN VIEW—Showing ready reference chart tells instantly what to use and how to use it.

JUST LOOK AT THIS

Improved Power Hack Saw

It is better made than any tool of a similar nature you ever saw before. Only the best of material is used in its construction, and your particular attention is directed to the improved arm and saw guide which keeps the saw perfectly in line. This saw cuts either round or square bars 6x6 in., and requires no attention after the work is in the vise.

IT STOPS AUTOMATICALLY WHEN THE PIECE IS CUT OFF

SEND FOR CIRCULAR AND PRICE

D. MCKENZIE, 9 NOTTINGHAM STREET GUELPH, ONT.



Both orders have to be completed so that all the cars will be available for this year's harvest.

G.T.P. Shops, Winnipeg.

The extensive shops of the Grand Trunk Pacific at Winnipeg are rapidly taking the form of finished buildings. The roundhouse is already roofed in and more than one half of the five thousand tons of steel used in the construction of the shops has been riveted in place. There will be thirteen separate buildings, eight departments, eight buildings of steel construction and five buildings of reinforced concrete. The shops and grounds will cover 300 acres and there will be seventeen acres of floor space in the thirteen buildings. The main building alone will be 130 feet wide, 880 feet long and 47 feet high. These shops will employ about 2,500 men to begin with, which force will be increased to 5,000 as business justifies. The work is expected to be completed by the end of this year.

Edgar Allen Manganese Steel Co.

To meet the constantly increasing demand in America for their Stag brand manganese steel products and particularly for railroad frogs and crossings, Edgar Allen & Co., Ltd., of Imperial Steel Works, Sheffield, England, are at present engaged in the erection and equipment of an up-to-date and very extensive plant at Chicago, Ill., for the manufacture of their specialties. This branch of their organization has just been incorporated at Springfield, Ill., under the name of Edgar Allen Manganese Steel Co., with a capital stock of \$300,000. Edgar Allen & Co., Ltd., maintain a sales office and warehouses at 330 St. James St., Montreal.

C.P.R. Fort William Shops to be Enlarged.

The C.P.R. machine shop, at Fort William, is to be doubled in capacity. An addition of 128 feet by 70 feet is to be built to the present shop, which when completed will make the machine shops in Fort William the next largest on the main line to those at Montreal, Winnipeg and Vancouver. Tenders for this structure are now being called for, and the award is expected to be made next week. With the enlarging of the machine shops it has been made known that Fort William is to be the headquarters of the mechanical department between Winnipeg and Chalk river. This will mean that all repair work to the locomotives between Chalk River and Winnipeg will be made at the Fort, William shops. Already, it is said that \$70,000 worth of machinery has been ordered for the new shops and that it will be shipped when the building is completed. In order to carry on the work in the new shops it will be necessary to increase the staff.

Wealth of Canada's Mines.

The mineral output of Canada last year was \$90,000,000, an increase of 50 per cent. over that of five years ago, and five times that of fifteen years ago.

The value of the mineral output of the Province of Ontario at present is about \$40,000,000, or one-third of that of the whole Dominion. This is four times what it was ten years ago.

WE MANUFACTURE

Power and Steam Pumps,
Condensers, Travelling
Cranes,
Etc.

Write for
new catalog

The SMART-TURNER
MACHINE COMPANY, Limited
HAMILTON, - ONT.



The railway development of Canada has in the past made known vast areas of mineral wealth, and will no doubt lead to the discovery of still greater deposits, especially in the region around Hudson's Bay.

Canada has sixteen hundred miles of Rocky Mountains, and the same range in Mexico and the United States produces about three million dollars' worth of precious metals to the mile.

Quebec's Progress.

With the many vast enterprises that are to be achieved in Quebec within the next five years, this city is about to enter on an era of progress that will considerably change the face of things and turn the ancient Capital into one of the most progressive and busy cities in the Dominion.

A brief estimate of the work to be done shows that no less than thirty-six millions and a half will be spent in Quebec during the next five years, and a detailed examination shows the cost of the various works as follows:

Quebec bridge and approaches, \$10,000,000.
 Dry dock and ship-building yards, \$5,000,000.
 Grand Trunk Pacific terminals, \$3,000,000.
 Quebec and Saguenay Ry., \$2,000,000.
 Q.R.L. and P. Co.'s improvements, \$1,500,000.
 Customs house and other Government public buildings, \$1,000,000.
 Harbor improvements, including extension Louise Dock, etc., \$2,000,000.
 Canadian Pacific Hotel and station extension, \$1,500,000.
 Four thousand new houses at an average cost of \$2,000 each, \$8,000,000.
 Civic improvements in Limoileu, etc., including two bridges over the St. Charles River, \$500,000.
 Battlefields Commission, \$1,000,000.

Orillia, Ont., Prosperous.

The E. Long Co. are constructing a \$50,000 machine plant.

The Dominion Government will construct an armory this summer on the Agricultural grounds.

T. A. Main will construct a large new block containing three store on the main street, costing \$20,000.

Mayor Goffatt has been informed by Mr. Andrew Carnegie that a grant of \$13,500 has been made for the purpose of constructing a free public library for Orillia. Tenders for this work will be asked for.

The Roman Catholic congregation will commence building next week a new \$50,000 church. The Methodist and Presbyterian congregations are also commencing next week to build Sunday Schools costing about \$30,000 each.

The Tudhope Carriage Co. are constructing a large automobile factory. They will manufacture the American Everett machine; every part will be manufactured under one roof. This will mean a big opening for high class mechanics.

The town is installing, through Engineer Willis Chipman, of Toronto, a modern sewerage plant, and will commence this summer to reconstruct the waterworks system. It will mean about \$150,000 expended on this work.

J. B. Tudhope, president of the Carriage Factories, Ltd., has made a request for about 75 houses to be constructed during the summer, to take care of the large number of mechanics that they will have to bring in to work in their new automobile plant. This work will be taken care of by a number of builders of the town.

The contract for the construction of the Orillia to Coldwater section of the C.P.R. will be let shortly. The C.N.R. will use these tracks into Orillia from Atherley, entering the Union Station with the C.P.R. at the foot of Mississaga street, in the heart of the business section of the town. The building of the bridges over the Narrows at Atherley, and construction throughout the town, including yards and station, will amount to about \$500,000, all which is to be completed by November.

CATALOGUES.

NOTES ON HIGH SPEED STEEL, SAWS, DRILLS, ETC.—Is the title of a compact little booklet being distributed by Alex. Gibb, Montreal. While particularly referring to Beardshaws "Conqueror" brand steels it carries several interesting pages on "The Treatment of Ordinary Crucible Steels." Hints and suggestions are given pertaining to forging and heating for ordinary tool steel; hardening of ordinary carbon steels; tempering steels. Those who are already using "Conqueror" steel will find this a handy little booklet and those using other brands will be materially helped by having one available. A copy will be sent for the asking.

BAILEY FURNACE.—A neat catalogue issued by Geo. J. Hogan, 401 Peoples Bank Bldg., Pittsburg, Pa., describes the Bailey combination sheet and pair furnace. Illustrations show the furnace equipped with American automatic Underfeed Stokers and the Stoker Attachment is fully described.

TAPS, DIES AND REAMERS.—Butterfield & Co., Rock Island, P. Q., manufacturers of taps, stocks, dies, screw plates, reamers, etc., have issued a 1910 catalogue of 90 pages, 6" x 9", on coated paper, illustrating and describing their lines. The different standard threads are shown including the U.S., International and French, sharp V, Whitworth and Acme, Reeco's and Derby Screw Plates in all sizes, for all classes of work including automobile repair work are shown. Machinists, blacksmiths' hand taps, etc., are described and pipe cutters, vises and special reamers are also included in the catalogue. Tables of prices are given, the catalogue being a useful and handy book of reference.

VERTICAL TURRET LATHE.—Pamphlet V-16 describes the vertical turret lathe manufactured by the Bullard Machine Tool Co., Bridgeport, Conn., for machining automobile and gas engine parts.

Special Subscription Offer With

The Financial Post

The pre-eminent financial and investment paper of Canada.

The Investor's Library:

The Investor's Primer . . .	\$1.00
The Art of Wall Street Investing	1.00
Mining Investments and How to Judge Them . . .	1.00
Pitfalls of Speculation . . .	1.00
Cycles of Speculation . . .	1.50
All with The Financial Post, one year	5.00
Any two with The Financial Post, one year	3.50

This offer applies to new subscribers or to old subscribers who send a new subscriber's name and the corresponding remittance.

FOR SAMPLE COPY ADDRESS

The Financial Post - Toronto

Watch this Space

YOU will be interested to know what we shall have to tell you about good **FORGINGS** and their uses.

Canada Forge Co.
 Welland - - - Ontario

Machinery Wanted and For Sale

RATES

One insertion—25c. for 20 words; 1c. a word for each additional word.

Yearly rate—\$2.50 for twenty words or less, 10c. a word for each additional word.

The above does not apply to notices under the head of "Machinery Wanted." These notices are inserted free for subscribers.

BELTING, PACKING, ETC.

BELTING, RUBBER, CANVAS AND LEATHER, Hose Packing, Blacksmith's and Mill Supplies at lowest price. N. Smith, 138 York Street, Toronto. (21f)

MANUFACTURING CENTRES.

FREE FACTORY SITES—Seven railroads, deep water, Niagara power, natural gas, low taxation, abundant labor. Welland, Ontario. B. J. McCormick. (12y)

RUBBER STAMPS, ETC.

B. CAIRNS, MANUFACTURER OF RUBBER stamps, stencils, steel stamps, burning brands. 77-79 Queen Street East, Toronto, Ont. (1f)

MACHINERY FOR SALE.

BARGAINS—One 34-in. Plain Oesterlein Milling Machine, new; One 14-in. x 6-ft. Porter Lathe with chuck and complete attachments, first-class order; One H.P. Gas Engine with complete attachments, first-class order. Kellogg & Co., 196 King St. West, Toronto.

MARINE GASOLINE MOTORS of unexcelled quality; jump spark type; two to eighteen horsepower; pleased to show our motors; send for new catalogue. Midland Engine Works Company, Midland, Ont. (1-11)

3 1/2 H. P. Gas Engine, complete with accessories, in first-class order. Kellogg & Co., 196 King St. West, Toronto.

FOR SALE—1 Gurney Scale Co. Foundryman's Testing Machine, with deflection indicator. Good as new. Standard Ideal Co., Port Hope.

FOR SALE—A complete set of patterns and equipment for the manufacture of an improved line of iron toys, such as trains, hose carts, hook and ladders, engines, pistols, banks, stoves, etc. An established demand for this particular line of toys. Everything necessary for the successful manufacturing of same. Very fine proposition for anyone interested. Reason for discontinuing manufacture lack of factory room on account of heavy lines of other materials. Address Box 107, CANADIAN MACHINERY, Toronto.

MACHINERY WANTED.

ONE PRESS, foot power preferred. Also 1/4 or 1/2 h.p. alt. current motor, 104 volt, 60 cycle. E. D. Smith, Magog, Que.

SHOP AGENT WANTED.

WE want an agent in every machine shop in Canada where fifteen or more men are employed, to take subscriptions to this Journal. Subscriptions are easily obtained and the work can be carried on by giving a few minutes to it in the noon hour. Liberal commissions allowed both for new subscriptions and for renewals. Write for terms. Agents' Dept. CANADIAN MACHINERY, 10 Front St. East, Toronto.

FIRE PROOF SAFES, VAULTS, ETC.

YOU need the best possible protection from fire! If your valuables are in one of our safes you can rest at ease; no fire is too hot for our safes and vaults to withstand. We manufacture vaults and safes to meet every possible requirement. Write for catalogue "S." The Goldie & McCulloch Co., Ltd., Galt, Ont. (1f)

MISCELLANEOUS.

COPELAND-CHATTERSON SYSTEMS—Short, simple. Adapted to all classes of business. Copeland-Chatterson-Crain, Ltd., Toronto and Ottawa. (1f)

DOUBLE YOUR FLOOR SPACE. An Otis-Fensom hand-power elevator will double your floor space, enable you to use that upper floor either as stock room or as extra selling space, at the same time increasing space on your ground floor. Costs only \$70. Write for catalogue "B." The Otis-Fensom Elevator Co., Traders Bank Building, Toronto. (1f)

EELIMINATE fire risk, save insurance, reduce maintenance costs and save money on your actual building work by using the Kahn System of Fireproof Construction. Used in many of the largest business premises on this continent. Write for catalogue. Trussed Concrete Steel Company of Canada, Limited, Walker Rd., Walkerville, Ont. (1f)

ELLIOTT-FISHER STANDARD WRITING-ADDING MACHINES make toil easier. Elliott-Fisher, Limited, Room 314, Stair Building, Toronto.

ERRORS AVOIDED—LABOR SAVED—Using the Superior Autographic Register. Three copies issued at one writing. 1st, invoice; 2nd, delivery ticket; 3rd, charge sheet, perforated for filing. No handling of carbons. High grade printing and neat invoices. Make full inquiry. Autographic Register Co., 191-193-195 Dorchester St. East, Montreal.

FASHION DECREES. Holland Linen correspondence stationery correct in style. Its beautiful writing service most attractive. Envelopes to match. Fashionable sizes and colors. Visiting cards, invitation and At-Home cabinets and writing tablets. Ask your stationer. W. J. Gage & Co. Ltd., Toronto.

FIRE INSURANCE. INSURE IN THE HARTFORD. Agencies everywhere in Canada. (1f)

FREE TEST. Prove our claim that "Klear Copy" Carbon gives the best, clearest, unsmudged copies of all typed matter at our expense. Send for sample package "K" free. Peerless Carbon & Ribbon Mfg. Co. of Canada, Limited, 180 Richmond West, Toronto.

GET THE BUSINESS. Increase your sales. Use Multigraph Typewritten letters. The Multigraph does absolutely every form of printing. Saves you 25 p.c. to 75 p.c. of your printing bill. Multigraph your office forms, letterheads, circular letters. Write us. American Multigraph Sales Co., Ltd., 129 Bay St., Toronto.

MODERN FIREPROOF CONSTRUCTION—Our system of reinforced concrete work, as successfully used in many of Canada's largest buildings, gives better results at lower cost. "A strong statement," you will say. Write us and let us prove our claims. That's fair. Leach Concrete Co., Ltd., 100 King St. West, Toronto. (1f)

MR BUSINESS MAN, are you progressive? It's up to you to test "Consolidated," our new process carbon paper. Because it costs less. Soft finish, without smutting, and clear, permanent copies. Write for sample sheets and prices. "Consolidated," Stratford, Ont.

SAVE 50% OF THE COST OF HANDLING merchandise by installing a Beath System of Overhead Carriers. Saves valuable floor space because the trackage is on the ceiling. Systems for all kinds of businesses, large or small. Write us for illustrated catalog. W. D. Beath & Son, 193 Terauley Street, Toronto. (1f)

SCOTCH PLAID STATIONERY is the latest creation for business and society correspondence. Paper and envelopes present a finished linen surface, most agreeable to the pen touch. Leading stationers have it. Write for samples. The Comp. Clark Company, Ltd., Toronto. (1f)

"SYSTEMS" stand for all that is best in loose-leaf binders and supplies, letter-heads, statements and in fact your office stationery of every description. Send us samples of what you are using—we will send you prices that will interest you. Business Systems, Limited, Manufacturing Stationers, Toronto. (1f)

THE "Kalamazoo" Loose Leaf Binder is the only binder that will hold just as many sheets as you actually require and no more. The back is flexible, writing surface flat, alignment perfect. No exposed metal parts or complicated mechanism. Write for booklet. Warwick Bros. & Rutter, Ltd., King and Spadina, Toronto.

MISCELLANEOUS.

THE METAL REQUIRED in a Modern Concrete Building. Our special facilities enable us to produce at minimum cost Concrete Reinforcements, Fenestra Steel Sash, Automatic Fire Shutters and Steelcrete Metal Lath. Complete stock, quick delivery. Before deciding write us for catalogue and prices. Expanded Metal and Fireproofing Co., Ltd., Fraser Ave., Toronto. (1f)

WANTED—A splendid opportunity for dealers to handle the best combination Duplicating, Addressing and Office Printing Machine on the market. Exclusive territory. Send name and address, giving occupation and references, to the Canadian Writerpress Company, Ltd., 33 John St., Hamilton, Ont. (1f)

WAREHOUSE AND FACTORY HEATING SYSTEMS. Taylor-Forbes Company, Limited. Supplied by the trade throughout Canada. (1f)

WHEN buying bookcases insist on having the best on the market—"Macey Sectional Bookcases." Carried in stock by all up-to-date furniture dealers. Illustrated booklet sent free on request. Canada Furniture Manufacturers, Limited. General offices, Woodstock, Ont. (1f)

YOU CAN DISPLAY YOUR GOODS TO BETTER ADVANTAGE through the use of up-to-date fixtures. We are specialists in the planning of stores and offices. Our catalogue contains illustrations of many new features and several handsomely equipped stores and offices. Shall we send you our catalogue? Jones Bros. & Co., Ltd., 30-32 Adelaide St. West, Toronto. (1f)

\$75 buys the best duplicating machine on the market. ACME will print anything a job-printer can do. Complete outfit; Acme Duplicating Machine; one tubular stand fitted with type cases; compartments plainly lettered and arranged like universal keyboard of the standard make of typewriters; one drawer for accessories and forms; 20 lb. font of typewriter type; one chase; one Acme ribbon any color with typewriter ribbon to match; one pair tweezers; two quins; one key; one oil can; and one set of registers. Sold with a guarantee. Acme Duplicator Co., Baltimore, Md., U.S.A.

BUSINESS OPPORTUNITY.

A PARTY holding a large interest in a well-established prosperous machinery manufacturing company on the Pacific coast wishes to dispose of part of his holdings to meet personal obligations. Can arrange if necessary for purchaser with proper qualifications to take an active part in the management. This is a splendid opportunity and investment for anyone wishing to get a start in a good, steady, legitimate, profitable business, in a young, growing country. Applicants who mean business, must have at least \$20,000. are invited to investigate. Write Box 102, CANADIAN MACHINERY, Toronto. (4)

MACHINISTS, ATTENTION!

MACHINIST'S TOOL-CASE FREE to one man in every shop. Address, with stamp, O. BURCH, Grand Rapids Mich. (3)

POSITIONS WANTED.

HIGH speed and carbon tool steel salesman, practical steel man, expert on forging, hardening and treating. High speed and carbon steel tools; capable of demonstrating and securing all possible results, conducting tests and selling. Experienced with modern machine shop methods, conversant with all the High grade steels on the market. Practical experience backed with intelligent diplomacy, metallurgy and chemistry. Open for position with house handling billets, pig, metal and tool steels. Address, High speed, Box No. 104, CANADIAN MACHINERY, Toronto. (4)

FACTORY SALESMAN and business solicitor, tireless energy, good mixer, practical mechanic, draftsman, cost estimator, experienced in closing deals, soliciting profitable business for products of machine, foundry, forge and structural shop. Age 35, at present with manufacturing concern. Reason for desired change satisfactorily explained. Open for position as travelling salesman and solicitor for manufacturing and jobbing plant in Western Canada. Address, Factory Salesman, Box 105, CANADIAN MACHINERY, Toronto. (4)

PRACTICAL MACHINIST desires position as general foreman or superintendent. Good systematizer, with executive ability. Can handle all grades of labor. Box 106, CANADIAN MACHINERY, Toronto. (6)

The Details of a Modern Shop Management System

This System, used in Actual Practice, was Described before the National Metal Trades Association, by Frederick A. Waldron, Consulting Engineer, New York.

By Frederick A. Waldron.

PRODUCING consists of manufacturing and delivering a complete article of maximum quality in a profitable quantity with reasonable profit at lowest cost and selling price.

The ideal organization for the manufacturer is to carry it all in his head—money received in the left-hand pocket, money to be paid out in the right-hand pocket, pay in cash, then what is left is the profit, plus or minus the mental estimate of gain or loss from work in process or stock. This method eliminates non-producers, clerks, selling force, cost department, draftsmen, promotion charges, high finance, etc. Fortunately for the employed, a man's capacity is limited and where his business exceeds a certain amount it is necessary for him to unload and organize to handle large problems. How can this be done with maximum profit?

The answer in part is the subject of this paper.

I wish to discuss the phases and details of this problem, not as a mentor to those assembled but to suggest what can be done with many plants that are running on the principle of 1885 or 1886 with a few fashionable so-called system frills on the outside.

Principal Point in Shop Management

Having been asked by many of what the principal point in shop management consists, I was at a loss at first to find an answer. After analyzing in detail and by a process of elimination it boils down to "knowing where you are at." The organization and methods hereafter described will tell you this with reasonable accuracy and expense and economic results:

The symbol method localizes expenditures.

The stock cards, stores or worked materials.

The time tickets, the efficiency of men and the cost of labor and machine hours.

The payroll, the expense and classification of labor.

The operation cards, sequence of work.

The instruction cards, how to do work and what to do it with.

The route cards, location of work in shop and a means of valuation of work in process.

Time study and operation analysis establish basic conditions.

Functionalizing of duties, an increase of machine output.

Bonus for superintendent and foremen gives co-operation.

Study of weakness in shop organization and methods develops an astonishing lack of basic detail and truth, with a desire to play to the galleries, local and shop politics, on the part of many

who desire to hold their jobs, combined with the following:

A. Incapacity for those in charge to give clear and explicit orders and instruct those under them.

B. Corresponding lack in those receiving orders to carry them out, spending more energy and time in thinking of some other way to do the work than doing it.

C. Too many minds for the orders to filter through before reaching the man behind the lathe.

D. Disregard of promises of completion of work in shop and the shipment of the same.

E. Lack of conception of the meaning of the words "thorough" and "complete."

F. Trying on of new ideas without knowing how to make them fit.

G. Patent medicine ideas of new systems, such as high prices, cost systems, Doolittle time system, P.T.'s. premium system, etc.

H. Expecting too much from managers, superintendents, and foremen and getting too little.

I. Humanity on the part of managers, superintendents and foremen in holding on to the job and protecting themselves. "Self-preservation is the first law of nature."

J. Lack of specific knowledge of capacity of speeds and feeds of machines by men and foremen.

SHOP MANAGEMENT SYSTEM

The article by Mr. Waldron gives a clear statement of what a modern shop system *should* and *should not* be. The value of *machine hours* is pointed out and illustrations are given.

The importance of *routing* the work through the shops is shown in a way that must impress the reader. *Routing* the work is *more remunerative* than a hap-hazard way of getting the work through the shops.

K. Lack of detail, instructions and systematic methods of seeing them carried out.

L. No system of routing work through shop.

M. Extravagant and injudicious advertising.

N. Jealousy.

O. Lack of team work.

P. Too much brain work in proportion to hand work.

Q. Too much unused and useless information.

R. Overcultivation of the inventive mind in proportion to capital invested.

S. No method for the training of the workmen.

From observation and experience covering a number of years has been evolved a method of organization for industrial work which, while it is not perfect, has shown such improvement in results over the regulation methods that I believe its description would be

of interest to you. There is nothing new in it, except the results, other than the co-ordinating of the best obtainable into an elastic organization which obtains the most direct results with the minimum number of forms and red tape. Thus is increased the efficiency not only of the hands, but the brains of an organization by making the brain work more complete and thorough and compelling the machines to work harder and more constantly, thereby cutting down the time elapsing between the receiving of an order and shipping of the goods, which will necessarily reduce the value of the work in process and increase the volume of output. The time which work is operated upon is oftentimes less than one-half the time that the work lies round the shop.

Data Needed for Shaping a Policy.

To gauge the management of a factory intelligently the following information is necessary:

1. Capital invested.
2. Productive and betterment labor.
3. Productive and betterment materials.
4. Expense, all kinds.
5. Average annual business, past.
6. Average annual business, estimates for future.

These facts are necessary as a guide for the most efficient policy to follow in shop management. The successful manager must know them to guide him in his work. The factory should then have the divisions as called for later and each should have apportioned to it, as nearly as possible, the expense burden it has to carry; next an estimate or record of the amount of productive labor and materials used in these groups or sections of the divisions. We now have data on which to shape the policy for the first year and will proceed to apply the following:

1. Functionalizing duties.
2. Forming an Advisory Committee.
3. Control of expenditures.
4. Time study for piece rates.
5. Distribution of information.
6. Determination of premium or bonus.
7. Machine hours.
8. Routing.
 - a. Operation lists, stores and worked material cards.
 - b. Production orders.
 - c. Standing orders.
 - d. Instruction card and drawings.
 - e. Requisition on stores.
 - f. Time card, clocks, and production department.
 - g. Inspection ticket.
 - h. Move orders.
 - i. Route card or schedule of work.
9. Payroll.

10. Analysis sheet.
11. Accounting.
 - a. Symbol sheet.
 - b. Proper use of symbol sheet with analysis sheet, time tickets and requisitions.
12. Costs.
13. Tickler.
14. Bonus system for superintendents and foremen.
15. Decision as to whether goods are to be made on special order or from stock.

Nos. 1, 4, 6, 7 and 10 are the vital points of this type of organization, and concentration on these will develop the necessity of the others and show gain even if carried out in a somewhat crude and amateur manner. Time will permit me to talk on these points only.

The essential difference in this type of organization from the ordinary type is the arrangement of duties and the dividing of the technical and mechanical work from the business or hustling end of the factory more definitely than is usually done.

All designing of product and tools, issuing of lists of machines on which the work is to be done, etc., are the function of the engineering division, while the chief of the producing division pushes it along the different lines by means of the routing system, and looks ahead, anticipating where the work is to be done and that all is ready to do with at the proper time. This insures greater rapidity in the work passing through the shop.

Importance of a Routing System.

My observations in this have shown that a well arranged method for routing work through the factory with duties properly functionalized increases its productive efficiency more than any premium, piece rate or bonus system, and, given the choice of only one, I should take a logical and consistent routing system to any of the others.

Take two factories exactly alike with an oversold product—one with a good piece rate or bonus system and a happy-go-lucky routing system, the other with a day work system and a first-class routing system—there is no question in my mind as to the latter showing a greater profit than the former, while a combination of the two will show results far beyond the most sanguine expectations. A good routing system automatically results in the following :

1. Gives basic cost information.
2. Locates a fall-down in output at once.
3. Locates all work and its conditions.
4. Relieves chiefs of divisions of "still hunts."
5. Compels chief and assistants to "watch out."
6. Records machine hours.
7. Insures accurate time charges.
8. Insures accurate account charges.
9. Shows up delays and their causes at once.
10. Shows work ahead for each machine and allows for rearrangement and redistribution.

11. Allows of most minute cost analysis if required; and if not, no unnecessary expense is insured for useless information.
12. Compels closer attention to details all along the line.
13. Reduces amount of wasted energy and materials.

In conjunction with the above a tickler system is most important, and a shop can be run on this system alone better than on no system at all.

The tickler form is a 4 x 6 in. slip of paper or card, provided with a blank space for the name of the party to whom it is to be delivered, with the subject and remarks. Below is a ruled space for dates on which the card is to be returned to the party whose name is on it. These cards are collected at night from a receptacle provided at desks and distributed in a filing cabinet by date; early the next morning all cards in folios of that date are taken out and distributed by a boy to those whose names appear on the card. This system is flexible and memoranda can be sent up and down the line. When once used, it becomes an indispensable adjunct to the factory.

Machine Hours.

The value of an accurate record of machine hours for computing costs approaches more accurately the ideal than

who runs it. If the machine was run 1,500 machine hours, the hourly charge would be \$1.04, or double the man's time.

The universal practice of adding a certain percentage to flat labor costs for overhead charges handicaps the actual cost of the work on smaller machines and at times causes the manufacturer to discontinue making an article which shows no profit on account of its having to carry the burden of the work done on a heavier machine. The machine hour, therefore, is a very logical method for distributing the overhead factory charges.

Another advantage of the record of machine hours is the check on foremen or superintendents applying for additional machinery when it is really additional tools that are needed or a reasonable method of maintaining the tools and machinery which he already has.

The machine hours are a better criterion of the efficiency of production than any records of the man's time. It is the machine through which the work must pass and the more constantly this machine is operated in turning out work the greater the volume of output becomes. It is therefore important that in the selection of the machines they should be selected with a regard to the interchangeability of tools and fixtures. It is much better to spend a few dollars for tools and repairs than a larger amount for machinery.

There are many level-minded business men who will spend any amount of time and money for correct methods of bookkeeping involving a bank balance of a few thousand, and yet will absolutely refuse to allow a factory to use sufficient clerical help whereby the means and methods of handling investments amounting to many thousand dollars can be increased in earning power. I cannot blame them, however, as the method of obtaining, recording and compiling manufacturing data is an expensive luxury, especially when such data is very old or cold when it reaches the eyes it was intended for. I have some rolls of paper collecting dust that have never been looked at that must have cost hundreds, yes, thousands, of dollars to compile. What is required is information on the spot that costs little to obtain and can be readily filed and compiled when required.

If basic conditions as to work in the shop are right and information as to fall-down in production is caught first hand and corrected at once, the bank balance will take care of itself.

Determination of Bonus for Workmen.

The amount of premium or bonus to be paid a workman depends on the following :

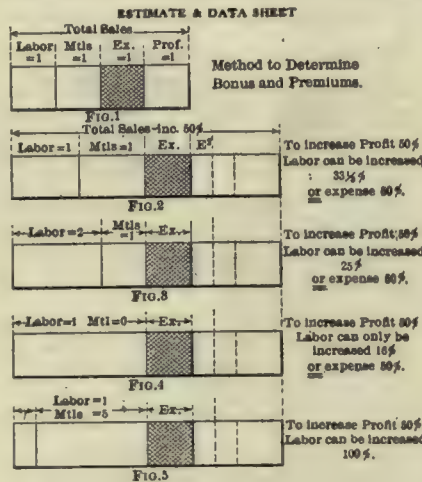

any other method, and is of far more importance to the factory than is generally admitted or recognized. A machine, bench or vise should carry with it its exact proportion of the overhead expenses, and it is much more important that these overhead charges should be distributed by the machine hours than charged as an aggregate per cent. to the item of labor. This is especially true where a factory operates a large variety of machines of extremely low and high valuations.

Illustration: A machine costing \$10,000 would have an annual overhead charge against it for depreciation, rental, power, etc., of \$1,500, based on 3,000 hours a year, or 50 cents per hour. This would be as much if not more than the hourly rate paid the man

Ratio of labor to material, expenses, selling price.

After assuming the amount of annual increase in business that is warranted by the condition of the market and comparing this with the producing capacity of the plant, it can then be determined from the relation of these two or to the advisability of offering additional reward to labor for increased effort. If the plant is oversold there is no question, and the amount it is oversold will form a guide for the initial calculation. Of course additional business turned out in a given time at the same price for labor and material will give you an increased profit, and from this increased profit it is to be decided what proportion can be divided between the expense and the additional rewarding of labor. Time study will then determine the basic condition in your factory and the above will serve as a guide as to how far you can afford to go. These data will also show what proportion you can afford to give to your superintendents and foremen as an additional reward for closer co-operation.

The accompanying diagram shows graphically the application of the above, which can be modified to suit different conditions.

Divisions and Their Chiefs.

Manufacturing can be grouped into the following general divisions, all of these functions entering into the manufacture of even the simplest article:

1. Engineering.
2. Producing.
3. Inspecting.
4. Accounting.
5. Maintenance.

Full authority should centre on a works manager, who should be an official of the company. Competent chiefs should be selected for each division in cases where they will have plenty to do. If the shop is small and the product simple there can be a combination of any number or all divisions under one man. It is a very small business, however, that can afford to do too much loading up of division chiefs. The specific duties of each should then be clear and detailed.

The organization and duties being outlined, letters of instructions are issued and forwarded to those interested, so that each division may be kept in touch as to what is required of them and also that which is taking place in other divisions.

Where new products, fixtures, plant expenses or other special expenditures are required a letter of authorization is issued by the works manager to the chiefs of the divisions giving the information required.

An advisory committee composed of division chiefs should be organized and

should meet at the option of the works manager to discuss matters relating to shop operation.

Engineering Division.

An engineering division in this type of organization is of paramount importance, and should have at its head an able and practical engineer of excellent executive ability and broad mechanical experience. Upon the competency of this man depends the methods of manufacturing and arranging of machinery, for the following reasons:

With a thoroughly organized engineering department, manufacturing can be carried on by grouping of machine tools of a similar character. On the other hand, if there is no engineering department, or the engineer is incompetent, manufacturing must be done by group methods by a variable class of machine tools, which involves a large original investment and duplicate of machinery in a plant and a man above the average ability and experience in charge of each group. Such men as will attain to the highest efficiency are hard to find, and the volume and quality of output cannot be obtained by this method that can be obtained by the grouping of similar tools with proper inspection. It will thus be seen that the entire economical problem of manufacture is primarily dependent on the chief of the engineering division.

Producing Division.

In this type of organization the chief of the producing division is not called upon to exercise any great ingenuity or skill on mechanical matters or detail methods of operation. These are supplied in the form of specific information by the engineering division.

The manufacturing or producing of an article commercially should not call for change of methods and operations every fifteen minutes. It should be the economical effort to turn the work out under constant pressure, a certain value for each day for every day in the year.

The instructions from the engineering department as to the routing of work, the tools to be used, the limits or toleration which are to be worked and the drawings for the work should be placed at the disposal of the chief of the producing division, his duty being to see that all hands and machines are working at the highest efficiency and every machine that is possible is kept running the maximum number of hours producing work. He should also see that there is as little delay as possible between one set of operations and the next.

The chief of the producing division, therefore, comes next in importance to the chief of the engineering division. On the latter depends the accuracy of the instructions to the chief of the producing division, or the path the

work has to follow, and to the former the speed with which these instructions are carried out. In other words, the chief of the producing division should be a hustler rather than a fine mechanic or engineer.

Inspection Division.

The most sensitive and delicate division in this type of organization is the inspection division, and its chief should be a diplomat and at the same time a man with sufficient firmness in his make-up to stand back of decisions which are made under his jurisdiction. He should be able to say "No" in such a way that it will not antagonize the entire organization.

Instructions as to inspection, gauges and fixtures for testing work are given to this division by the chief of the engineering division, and the chief of the inspection division has to see that they are lived up to. All troubles occurring in the making or assembling of the work are referred to the chief of the inspection division, who decides as to the quality of the work, and in case of serious trouble takes the matter up with the engineering division, where it is rectified, not only in itself, but also where it may relate to the other parts of the mechanism.

This division has entire jurisdiction over the inspection of all raw materials, work in process, finished stock or materials, and tools, jigs and fixtures.

Where machine operations are many and particular, as to limits and finish, traveling inspectors should be placed in the factory, who pass on these operations before the machine foremen are allowed to proceed with the machining of any number of parts on any operation; also checks speeds and feeds of machines. These inspectors save from three to five times their salaries in a year by bringing up the standard of work, saving of material costs, together with accumulative profits from increased output of acceptable parts.

They are of great assistance to the chief of the producing division and to the foreman, as well as increasing the volume of output by preventing extended operations on bad work.

On this division depends largely the smoothness with which the work passes through the shop and its cost, together with the grouping of work in assembling room ready for quick and accurate assembling. You will note that the operation of this division is dependent upon the judgment of the chief of the engineering division for the accuracy with which tolerations are determined and instructions given as to the quality and finish of work.

Maintenance Division.

The chief of the maintenance division, where the factory is large, should be a

good executive mechanic, with a reasonable amount of technical education. Many of the larger concerns employ a high grade engineer to supervise this division, which furnishes plans and specifications for new buildings and equipment and handles the work of new construction as well as maintenance. Many firms consider this economical. The speaker, however, is of the opinion that the practice adopted by the textile organizations of this country in having most of their construction and engineering work done by outside parties, leaving the routine work of the maintenance to one of fair executive ability, is much more economical in the long run than to have plans and specifications for buildings and their equipment prepared by themselves.

Where the organization is not large or the duties of the chief of the maintenance division are not sufficient to keep him fully occupied this division is combined with the producing division or the engineering division, preferably the latter.

Accounting Division.

The chief of the accounting division should be a man well trained in the principles of bookkeeping, a good analyst and with enough familiarity with shop methods to prevent being fooled entirely by figures. He should be systematic and a good disciplinarian, and insist upon his subordinates maintaining records to date.

With these methods a large part of the maintaining of records is automatic, and a general supervision of the accuracy of the figures and their prompt posting by his subordinates are particular qualifications. In addition to the above, he should watch the value of stock on hand, notifying the proper parties when abnormal conditions are approached and see that orders are entered or canceled as conditions require.

The instruction card is the means of transmitting to the chief of the producing division and his foremen details as to operations, i.e., tools and fixtures, etc., to be used; speeds and feeds of machines and other instructions which might be pertinent to the economical and accurate production of the work.

The operation card gives a description and sequence number of operation on the different parts and should be arranged so that it can be looked in a box in charge of the engineering division, and when changes are made in the sequence of operations these cards are taken out and placed in their new position. This saves rewriting lists every time a change is made.

An inventory of stock on hand in storeroom should be taken and transferred to cards.

There should be separate cards for stores and worked materials. By stores

are meant all finished or raw materials kept in stock on which no work has been performed by the factory. After the pieces for the stores have been issued and work done upon them in the factory they are returned to the storeroom as "worked materials" and issued to the assembling room for assembling into final product. Requisitions for worked materials are not entered on analysis sheet when issued for same symbol numbers under which they are manufactured.

Routing.

I can positively state that the location of every piece of work covering 1,300 operations in active circulation in a factory can be determined without hunting around the shop. This is practically the block signal system of the shop, in which the workmen or work is the train and the clerk in the production department is the signal man.

The man's pay is made up on his time card, and no man can get a new ticket on a job until his own time ticket is returned and stamped, the new ticket being stamped out at the time the old is stamped in by a block registering hours and tenths of hours.

The time ticket has the letters "F" and "X F." provided on it. If a job is not finished at the end of the day, the "F." is crossed off and a new ticket made out for the man, which is given to him the next morning with the same charge symbol upon it. If, however, the "X F." is crossed off, indicating that the job is finished, the man in charge of the production department places his ticket in a box, and before it goes to the time clerk, it is marked off on the route card and an order to move work to next machine is issued for the next operation.

Move orders are not issued for operations that run in sequence on different machines of the same group. They are issued, however, where work passes from one group to another or to the inspection and storerooms. The use of move orders will reduce the number of men used for trucking in the factory 30 per cent.

The one requisite for efficient management is a simple and comprehensive accounting system accurate in its information and inexpensive to maintain. For this purpose all transactions can be captured as follows:

1. Capital.
2. Profit and loss.
3. Production.
4. Maintenance.
5. Expenses.

There can be subdivisions so as to give detailed information as requested either by symbols or charge numbers, or both.

The analysis sheet as used in this method is a combination of a loose leaf shop ledger and cost card. These can

be taken out for any one of the charge symbols, authorization numbers or other special order numbers, the details posted thereon directly from requisition, vouchers or payroll. These sheets are then closed in the final productive accounts.

The production account sheets are credited with sales, increase in inventory and closed to profit and loss sheet.

The betterment account sheets are closed in to expense accounts and capital by a predetermined ratio or actual charges.

Law Efficiency of the Average Machine Shop.

The average cotton mill produces from 80 to 92 per cent. of its theoretical efficiency, while the average machine shop seldom reaches 30 per cent. With proper training and management this can be brought up to 80 or 85 per cent., yet when Dr. Fred W. Taylor, dean of industrial engineering, says that the output of the average factory can be doubled, the satisfied owner or manager wonders why the other fellow does not take advantage of it, never stopping to think that he needs it as much if not more. This is not impossible. It is possible and probable, and some of the illustrations will show that with even an ultimate efficiency of 60 to 70 per cent. the output of many plants can be doubled over what they are now producing.

I do not think that the sole reason for the increase in the output cited was the introduction of the forms illustrated, because you may carpet a factory with forms and not obtain the desired results. It requires intelligence to use forms, also requires a persistent, untiring energy and firmness on the part of the management to keep an organization working together with them at the start.

More diplomacy and patience have to be used in teaching those at the top than the rank and file to adopt economical and systematic shop methods. In no case have wages been reduced, and in every case the earning capacity of the men per day has been increased and the total cost of the product reduced.

The fundamental principles, however, are summarized in the training of the superintendent, foremen and workmen to systematic habits and convincing the officials of a company that a constant and systematic endeavor to classify and functionalize duties and route work is more remunerative than the continual harassing of the overburdened and oftentimes underpaid shop manager or superintendent.

Forget the ratio of nonproductive help to productive and gauge the efficiency of a factory by the value of output per dollar of total payroll.

The Power Required by Machine Tools to Remove Metal*

Cutting Tools are Divided into three Classes—Lathe Tool Type, Drills and Milling Cutters, Calculators for these Classes of Tools.

The power required to remove metal depends upon the nature of the cutting tool and the amount of metal removed per minute. Cutting tools may be divided into three general classes: (a) lathe-tool type; (b) drills; (c) milling cutters.

Lathe-Tool Type.

The lathe tool is used on lathes, boring mills, planers, shapers and slotters. Tests show that the power required by a tool of this kind when removing metal depends upon the cutting angle of the tool and the number of cubic inches of metal removed per minute. From observation and data obtained by means of the graphic recording meter, and the use of tools having a cutting angle of about 75 to 80 degrees, the curve shown in Fig. 1 was obtained. The results were independent of the cutting speed, feed and depth of cut, and show that a definite relation exists between the horsepower required to remove metal and the number of cubic inches removed per minute. The cubic inches of metal removed per minute were found to be as follows:

- (a) area of cut (square inches) \times cutting speed (feet per minute) \times 12
- (b) area of cut (square inches) \times depth of cut (inches) \times feed (inches per revolution.)

The h.p. required to remove metal with the tools ordinarily employed can be expressed by:

$$\text{h.p.} = \text{a constant} \times \text{cubic inches removed per minute.}$$

The constant varies with the kind of metal removed.

In order to estimate the amount of power required to remove a given amount of metal per minute the graphic method shown in chart 1 has been designed. This diagram is a multiplication table; those familiar with analytical geometry will recognize the equilateral hyperbola whose equation, referred to its asymptotes, is $x y = \text{constant}$.

To determine the cutting speed the usual procedure is as follows.

$$\frac{\text{Cutting speed (ft. per min.)} \times \text{diameter} \times \text{r.p.m.}}{12} = \text{constant} \times \text{diameter} \times \text{r.p.m.}$$

In the diagram each hyperbola corresponds to a given cutting speed. The co-ordinates of all diameters and spindle speeds producing the same speed inter-

secting speed corresponding to any diameter, rotation at any number of revolutions per minute, is found indicated on the hyperbola passing through the intersection of the co-ordinates corresponding to the given values of diameter and revolutions per minute.

In a similar manner an area corresponding to any depth of cut in ins. and feed in inches is obtained, and also the cubic inches of metal removed per minute can be determined from the area of cut and the cutting speed. The directions for using the diagram are given in connection with it.

With the cutting tools ordinarily employed the following values have been found by tests to exist for the h.p. required to remove 1 cubic inch of the following metals, per minute:

Brass and similar alloys.	0.2 to 0.3
Cast Iron	0.3 to 0.5
Mild steel (0.30% - 0.40% carbon)	} 0.6
Wrought iron	
Hard Steel (0.50% carbon)	
Very hard fire steel	1.50

It must be remembered that these constants represent general average conditions; considerable variation may occur where special cutting tools are used and special grades of metal are encountered.

Lathes.

The following examples will explain the application of chart 1 to lathe work: Example: Diameter of work—5.5 in.; spindle speed = 45 revolutions per minute; depth of cut = 0.45 in.; feed per revolution = 0.06 in.

Find the intersection of the horizontal line through 5.5 inches diameter of work, and the vertical line through 45 revolutions per minute spindle speed. The curves passing nearest this intersection correspond to a cutting speed of 63 and 68 feet per minute, indicating by interpolation a cutting speed in this case of 65 feet per minute. The area of cut, with depth of cut 0.45 inch and feed 0.06 inch in 0.027 square inch. The cubic inches of metal removed per minute, corresponding to an area of cut 0.027 square inch and a cutting speed of 65 feet per minute, is determined by finding the intersection of the horizontal line passing through 0.027 square inch area of cut and 65 feet per minute. This intersection is between the curves corresponding to 19.2 and 21.6 cubic inches, showing that about 20 cubic inches of metal are removed per minute. If the metal removed is wrought iron, the h.

p. required is $0.6 \times 20 = 12$ h.p. If 0.50 per cent. carbon steel is turned, $1 \times 20 = 20$ h.p., is required. Brass would require $0.25 \times 20 = 5$ h.p.

Boring Mill.

Example: Diameter of work = 45 inches; speed of table = 4.5 revolutions per minute; depth of cut = 0.25 inch; feed = 0.10 inch per revolution.

The diameter of work goes only to 10 inches in the vertical column of the diagram. These may be multiplied by 10, and if used with the spindle speeds as they stand, the results in the oblique column of cutting speeds must be multiplied by 10. In case of large diameters the spindle or table speeds are usually low. The simplest way to use the diagram in these cases is to interchange diameter of work and spindle speed, i.e., assume that the diameter of the work is and the table speed under 1, 2, 3, etc., in the vertical column. In the problem under consideration the cutting speed is as follows:

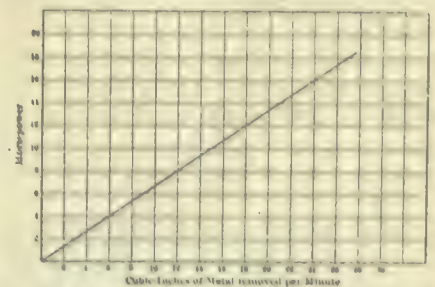

Fig. 1.—Relation Between Horse Power and cu. ins. metal removed; Mild Steel, 0.40 per cent. Carbon.

The intersection of the horizontal line through 4.5 and the vertical line through 45 correspond to a cutting speed of 52 feet per minute. The area of cut is 0.025 square inch. The intersection of the horizontal line through 0.025 square inch area of cut and the vertical line through 52 feet per minute cutting speed lies between curves representing 14.4 and 16.8 cubic inches, indicating that 15 cubic inches are removed per minute. If cast iron of a soft quality is removed the power required for cutting will be $15 \times 0.3 = 4.5$ h.p. If the cast iron is of hard quality, $0.5 \times 15 = 7.5$ h.p., will be required.

Shaper or Planer.

Example: Depth of cut = 0.75 inch; feed per stroke = 1-16 inch; cutting speed = 45 feet per minute (from characteristic of planer or shaper).

$$\text{Area of cut } 0.75 \times 1-16 = 0.046 \text{ square inch.}$$

* From Journal of American Society of Mechanical Engineers.

sect on the same hyperbola. The cut-

The cubic inches of metal removed per minute, corresponding to an area of cut of 0.046 square inch, and a cutting speed of 45 feet per minute, is 24. The power required for cutting in the machine a hard grade of cast iron will under these conditions be $24 \times 0.5 = 12$ h.p.

In a planer the power required for reversing is usually considerably more than that required to cut metal, depending upon the design of the reversing mechanism, the flywheel effect, and the speed characteristic of the motor. In a shaper the power required to reverse is not very great, and is usually less than the power required for cutting.

Slotter.

In most cases the cutting tool is fed inwardly on this type of machine; the following example shows how the diagram is used to determine the rate of removing metal. With other methods of feeding the tool the diagram is used in the same way as in the case of a planer or a shaper:

Example—

- Width of tool and cut 0.5
- Feed per stroke 0.06
- Cutting speed 35 f.p.m.
- Area of cut 0.5×0.06 0.03 sq. in.

Drills.

The power required in drilling operations can also be expressed as a constant times the cubic inches of metal removed per minute. The conditions are, however, more complicated than in the lathe tool, since the friction of the drill and the chips on the sides of the hole

increase the power requirement as the drill enters the metal. This is especially true when cast iron is drilled, as chips have a jamming action. The variable cutting speed at the cutting edge of the drill, from zero at the centre to the peripheral speed of the drill, also causes a jamming action and tends to increase the power per cubic inch per minute over that required to remove the same amount of metal by means of the lathe tool type. With drills generally employed, the value per h.p. per cubic inch of metal removed per minute, is about double that required by ordinary lathe tools.

Plate 2 is a diagram with full instructions for determining the cubic inches of metal removed with drills. The constants for determining the power required are about double those for lathe tools:

Example—

- Size of drill 2 in.
- Feed per minute 2.5 in.
- Speed of drill 150 r.p.m.
- Metal drilled: cast iron.

The peripheral or maximum cutting speed of the drill is found as follows. (Rule a, Plate 2): The horizontal line corresponding to a diameter of 2 in. intersects the vertical line corresponding to 150 r.p.m. on the curve corresponding to a cutting speed of 77.5 ft. per min. The area of the 2 in. drill (rule c) is 3 sq. in. This area at a feed of 2.5 in. per min. corresponds to removing 7 cu. in. per min. (rule d). For cast iron the

h.p. per cu. in. per min. is about 0.8, twice that for lathe tools, hence the power required to drive the drill in this case is $0.8 \times 7 \dots 5.6$ h.p., which agrees closely with an actual test. For mild steel the power required is $1.2 \times 7 \dots 8.4$ h.p. In drilling a hole of this size the friction of the chips does not increase the power materially as the depth of the hole increases, since there is sufficient space for the drill to free itself of chips.

Milling Cutters.

Plate 3 is a diagram with full instructions for determining the amount of metal removed per minute by a milling machine.

Example:

- Width of cut 8 in.
- Depth of cut 0.2 in.
- Advance of table per min. . . . 5 in.
- Area of cut is $8 \times 0.2 \dots 0.16$ sq. in.

To find the cubic inches of metal removed per minute, find on the diagram the intersection of the horizontal line through 0.16 sq. in., and a vertical line corresponding to a table advance of 5 in. per min. The curve passing through this intersection corresponds to a rate of cutting of 16 cu. in. of metal per min. For machinery steel or mild steel, the power required by a horizontal milling machine of this type is about 1.6 per cu. in. per min., making the total requirement $1.6 \times 16 \dots 25.6$ h.p. A

DIRECTIONS FOR USING PLATE 1.

- a. To find cutting speed: From intersection of horizontal line corresponding to diameter and vertical line corresponding to spindle speed, follow nearest curve and use value found in oblique line of figures marked cutting speed.
- b. To find area of cut: From intersection of horizontal line corresponding to depth of cut and vertical line corresponding to feed, follow nearest curve and use value found in oblique line of figures marked area of cut.
- c. To find cubic inches of metal removed per minute: From intersection of horizontal line corresponding to cutting speed follow nearest curve and use value found in oblique line of figures marked cubic inches of metal removed per minute.
- To use curve, knowing diameter of work, spindle speed, depth of cut and feed, find cutting speed from (a) area of cut from (b) and cubic inches of metal removed per minute from (c).

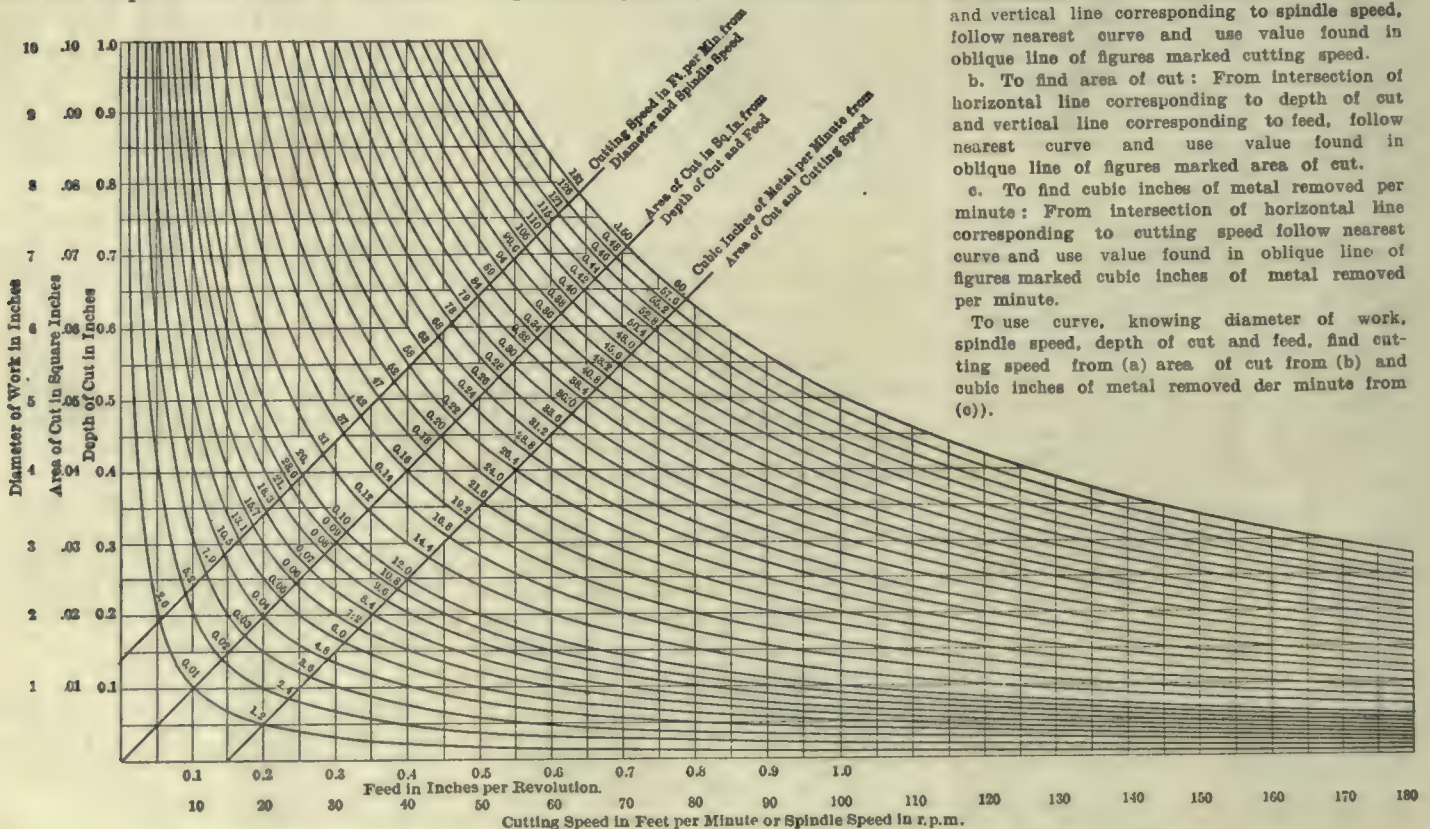

PLATE 1 MACHINE TOOL CALCULATOR FOR LATHES, PLANERS, SHAPERS, SLOTTERS AND BORING MILLS

vertical miller requires about 1 h.p. per cu. in. per min., or 16 h.p. under the foregoing conditions.

The power required by milling cutters varies according to their construction, and care should be employed to determine the proper constant for each class of cutters. By means of tests made with

the graphic meter on motor-driven tools the proper constant can easily be determined in any given case.

DIRECTIONS FOR USING PLATE 2.

a. To find cutting speed: From intersection of horizontal line corresponding to spindle speed follow nearest curve and use value found in oblique line of figures marked cutting speed.

b. To find in inches per minute from feed per revolution and spindle speed: From intersection of horizontal line corresponding to feed in inches per revolution and vertical line corresponding to spindle follow nearest curve and use value found in oblique line of figures marked feed in inches per minute.

c. To find area of drill from diameter of drill use curve on left side of figure: Find intersection of vertical line corresponding to diameter of drill with the curve; follow the horizontal line passing through this intersection and obtain area under area of drill in vertical column.

d. To find cubic inches of metal removed per minute: From intersection of horizontal line corresponding to area of drill and vertical line corresponding to feed per minute follow nearest curve and use value found in oblique line of figures marked cubic inches of metal removed per minute.

Knowing diameter of drill, spindle speed and feed per revolution, find cutting speed from (a) and cu. in. metal removed per minute from (b), (c) and (d).

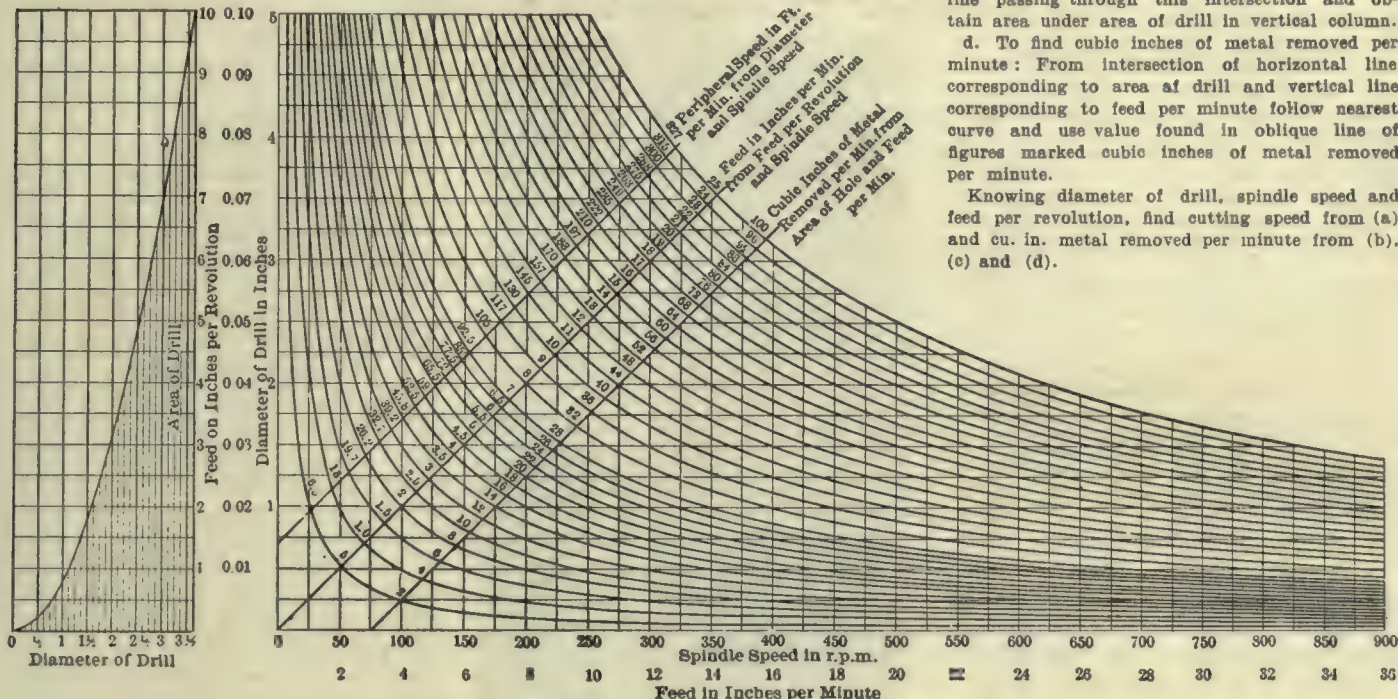

PLATE 2 MACHINE TOOL CALCULATOR FOR DRILLS

DIRECTIONS FOR USING PLATE 3.

a. To find cutting speed: From intersection of horizontal line corresponding to diameter and vertical line corresponding to spindle speed of cutter, follow nearest curve and use value found in oblique line of figures marked cutting speed.

b. To find area of cut: From intersection of horizontal line corresponding to depth of cut and vertical line corresponding to width of cut, follow nearest curve and use value found in oblique line of figures marked area of cut.

c. To find cubic inches of metal removed per minute: From intersection of horizontal line corresponding to area of cut and vertical line corresponding to advance of table per minute follow nearest curve and use value found in oblique line of figures marked cubic inches of metal removed per minute.

To use curve, knowing the diameter of cutter, spindle speed, depth of cut, width of cut, and advance of table per minute, find cutting speed from (a) area of cut from (b), cubic inches metal removed per minute from (c).

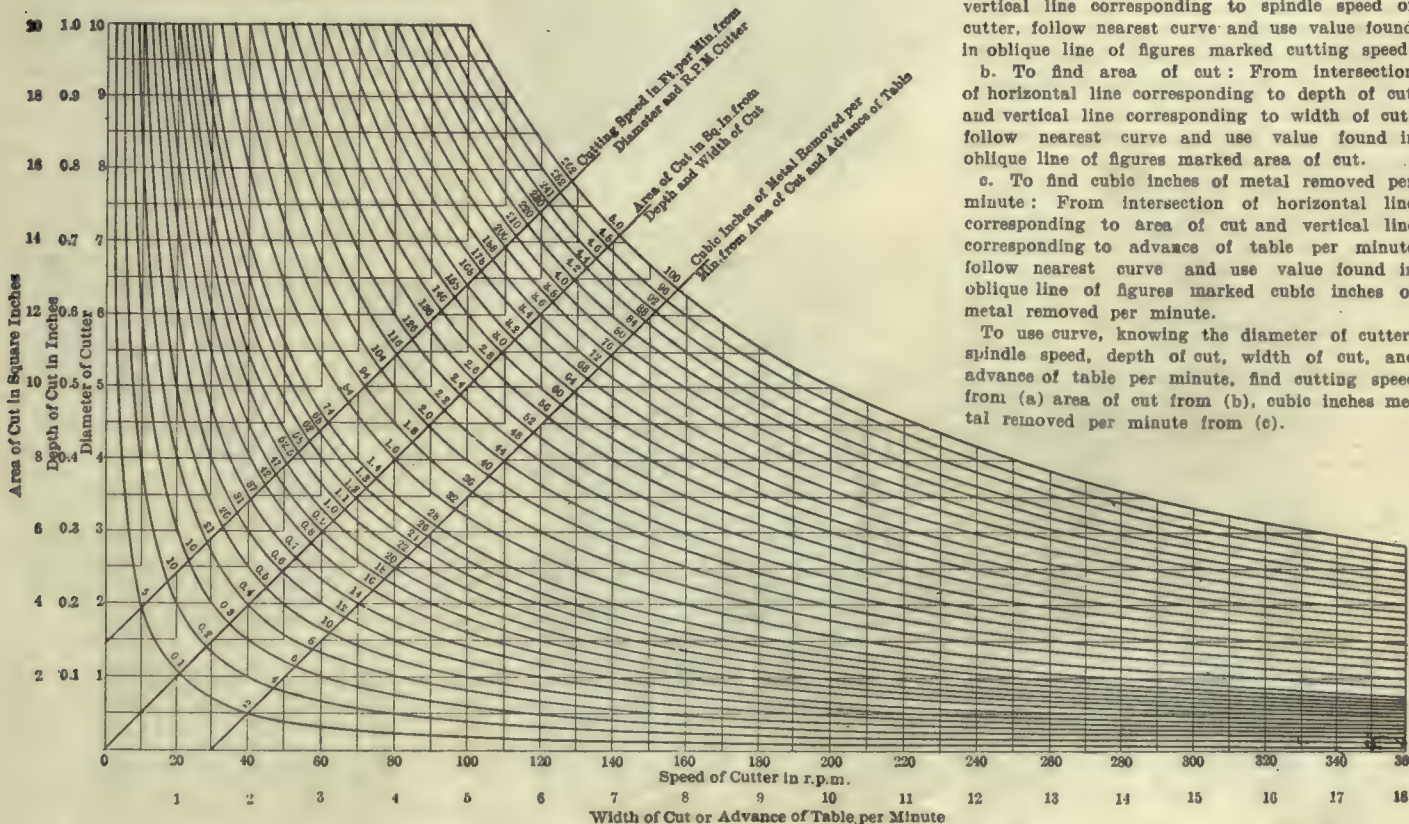

PLATE 3 MACHINE TOOL CALCULATOR FOR MILLING MACHINES



SPEAKING TUBE ECONOMY.

By M. E. D.

Our stock room is on the ground floor while the cost department is on the second floor. In connection with our cost keeping system it was often necessary to make trips from the cost department to the stores department to look up prices. This consumed a great deal of time of the cost clerk, who desired the information and one of the stores clerks.

It was decided, after considering the question, to instal a speaking tube between the two departments, with a whistle on either end so that a clerk in the stores department could call a clerk in the cost department or vice versa without having to walk up stairs.

This arrangement also saved considerable time. Formerly a cost clerk had to walk downstairs and wait while the stores clerk hunted up the desired information. Now the cost clerk can call up the stores department, ask the question and receive the answer through the speaking tube, without losing the time walking up or down stairs or in waiting in the stores department, while the stores clerk was looking up the information desired.

The tube, installed, cost about \$15. During the day about ten trips were made on the average by clerks up and down stairs. Estimating the time lost by one person on each trip, the total loss per day would be 100 min. per day or 300,000 min. per year equals 500 hrs. If the average wage is 20 cents per hour the total loss is \$100 per year, which is practically wholly eliminated by an expenditure of only \$15.

FIGURING OVERHEAD CHARGES.

By K. Campbell.

In shops it is a difficult matter to fix the overhead charges. Take a jobbing shop for instance with a machine and plating department. A manager of one of these wondered why he always "fell down" in obtaining contract for the plating department, his price being invariably higher than his competitors. He began to do some thinking. He figured it out and by his new way of figuring he was able to keep the plating plant busy.

He had been accustomed to figure the overhead charges for the whole plant, and this came, with profits, to about 80

per cent., so that if an article cost \$1 for productive labor, the charge to the customer would be \$1.80. As a result of his thinking, he investigated and found the overhead charges in the plating department were not as high as that of the machine department, and the percentage added was reduced to about 60 per cent., which fact allowed him to compete satisfactorily with other companies in the same line.

In figuring overhead charges or "Department Diffused Expense," Mr. Daly, of the National Cash Register Co., Toronto, has found it satisfactory to figure the per centage on the preceding twelve months. Thus for April, 1910, the percentage is taken from the twelve months preceding. As soon as May 1 comes the month of April, 1909, will be dropped and the percentage will be figured on the twelve months, May, 1909, to April, 1910, inclusive.

In some plants it is customary to take a fixed percentage as the overhead charge, but this does not appear to be the best practice though several arguments have been given in its favor, that of making the factory attain the minimum overhead charge. When a plant

is not busy the charge increases, while if the shops are busy, the machinery is in continuous operation, and the men crowded with work are kept busy, the percentage is lower. The system of using the figures of the previous twelve months for calculating overhead charges, therefore, appears to me to be a good system.

DEPRECIATION IN VALUE OF MACHINE TOOLS.

A method frequently used in calculating the depreciation in value of a machine tool is to allow 10 p.c. of a reducing balance; that is, 10 p.c. of the first cost if charged off the first year, 10 p.c. of the remaining cost, the second year, and 10 p.c. of the second remainder the third year, etc. This method is based upon the fact that the apparatus actually decreases in value year by year. Allowance for depreciation in any given year can be made easily by the aid of the curve in Fig. 2. This curve gives the percentage of the first cost corresponding each year to 10 p.c. on the reduced balance. For example, the curve shows that the depreciation on a tool that has been in service five years will be 6.6 p.c. of the

Type of Machine	CHARGES PER HOUR				Depreciation	Power	Total or Mch. Hr. Rate
	Fixed	Variable	Salaries	Interest			
Vertical Boring Mills.							
40 in.-60 in.....	\$0.02	\$0.25	\$0.15	\$0.05	\$0.05	\$1.01	\$0.51
72 in.-100 in.....	0.04	0.45	0.25	0.08	0.08	0.01	0.91
10 ft.-14 ft.....	0.05	0.80	0.40	0.15	0.15	0.02	1.57
16 ft.-24 ft. Ext.....	0.08	2.00	1.00	0.30	0.30	0.03	3.71
Average per cent of total....	3%	52%	28%	8%	8%	1%	100%
Radial drills, 5 ft.....	\$0.02	\$0.30	\$0.20	\$0.03	\$0.03	\$0.01	\$0.59
Radial drills, 10 ft.....	0.04	0.60	0.35	0.09	0.09	0.01	1.18
Average Per Cent of Total..	3%	51%	31%	7%	7%	1%	100%
Engine Lathes:							
30 in.-40 in.....	\$0.02	\$0.25	\$0.12	\$0.04	\$0.04	\$0.01	\$0.48
40 in.-60 in.....	0.03	0.50	0.25	0.10	0.10	0.01	0.99
Average Per Cent of Total..	3%	51%	25%	10%	10%	1%	100%
Planers:							
36 in.-56 in.....	\$0.04	\$0.55	\$0.30	\$0.05	\$0.05	\$0.01	\$1.03
7 ft.-10 ft.....	0.06	1.10	0.60	0.15	0.15	0.02	2.08
12 ft.-14 ft.....	0.15	2.60	1.40	0.25	0.25	0.03	4.83
Average Per Cent of Total..	3%	55%	30%	5.5%	5.5%	1%	100%

Fig. 1.—Table of Machine—Hour Rates.

original cost. If this cost was \$4,500, the allowance for depreciation during the sixth year according to the 10 p.c. reducing balance method is $\$4,500 \times .066$ equals \$297. Since this is 10 p.c. of the reduced cost, the value of the tool at the end of the fifth year is \$2,970.

Tools designed for special work will be discontinued after a comparatively limited period, and therefore, depreciate

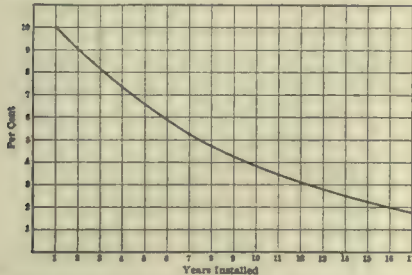

Fig. 2.—Depreciation at 10 p.c., Reducing Balance

in value much more rapidly than is indicated by the foregoing method: a special allowance frequently made for such tools is generally known as utility depreciation.

Fig. 1 contains a summary of machine hour rates obtained by this method. It is assumed that machines have been installed six years, so that the depreciation is 6 p.c. on a basis of 10 p.c. reducing balance.

NEW OFFICES OF MUSSENS LIMITED.

Mussens Limited, Montreal have just moved from their old offices on the corner of Victoria Square to a large five storey building on the opposite side of St. James St. at 318 St. James St.

Increases to the staff caused by the expansion of business had rendered the old offices too congested, and the show space for machinery and supplies was entirely inadequate. By the new move they have been enabled not only to lay out more commodious offices but reserve two floors for exhibition purposes. The new offices and show-rooms and also their warehouses which were purchased several years ago and which are excellently equipped for handling heavy machinery are shown here. The warehouses have a capacity of about 100 carloads of stock, and have a wide driveway running clear through the building from end to end opening on two streets. They are excellently located near the railroads and navigation companies.

Mussens Limited now have branch offices and warehouses in Cobalt, Winnipeg and Vancouver and also offices alone in Toronto and Calgary. From a small beginning this firm has become one of the largest of its kind in the Dominion of Canada. Their principal lines are machinery and supplies for railways, mines, contractors, municipalities and machine

shops. They have a well equipped engineering department which looks after the designing, supplying and erecting of complete plants for various purposes such as quarrying, mining, etc.

Their latest move is another indication of the rapid and steady growth of this firm, which has since its inception attained a reputation for reliable and efficient business methods.

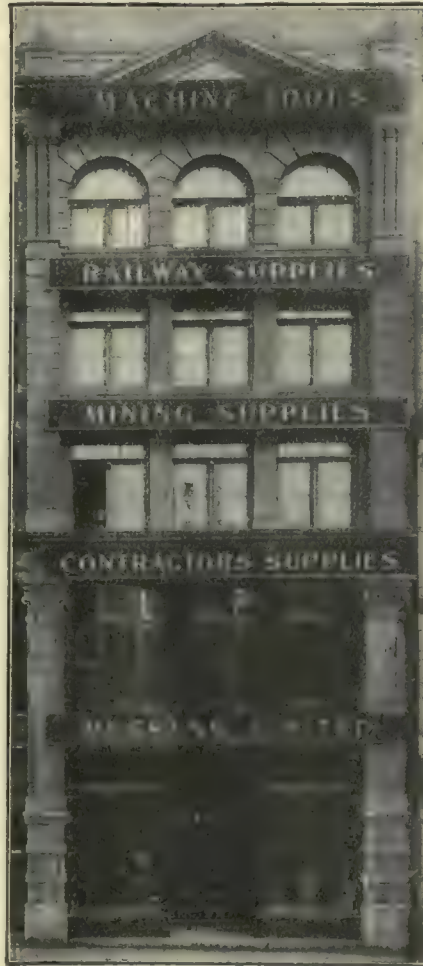

New Head Offices of Mussens Limited, Montreal.



Warehouses of Mussens Limited Montreal.

OVERHEAD CHARGES AND MACHINE-HOUR RATES.*

The following analysis outlines a method of determining the hourly overhead charges per machine tool, which will be called the machine-hour rates. Over-head charges can be grouped in three main classes:

A Charges against the entire factory.

a Fixed charges: these include interest and depreciation, taxes and insurance on buildings, grounds and accessories.

b Variable charges: these include repairs and renewals on buildings and accessories, omitting all charges which can be set off directly to a particular section of the factory; charges against the store room and the tool room; defective design, material or workmanship; printing and stationery; lubricants and general manufacturing supplies.

c Salaries (not chargeable to a definite section): these include cost of superintendence (manager, superintendent, foreman); engineering and drawing; clerical force, including office boys and general laborers.

B Charges against each section of the factory.

a Fixed charges: including an equitable portion of the total factory fixed charge and interest, and depreciation on auxiliary apparatus located in the section (except machine tools).

b Variable charges: these include a portion of the variable charges as well as similar charges belonging to the section, such as repairs and renewals, storeroom and tool room charges, defective design, material

* From a paper on Electric Motor Applications read before American Society of Mechanical Engineers by Charles Robbins.

- and workmanship, lubricants and manufacturing supplies.
- c Salaries: including a portion of the total salaries as well as those belonging exclusively to the section, that is, foremen, clerks, errand boys, laborers, cranemen, etc.
- C Charges against each machine tool.
- a Portion of fixed charge.
- b Portion of variable charge.
- c Portion of salaries charge.
- d Interest on cost of tool, fairly taken at 6 p.c.
- e Depreciation of value of tool (see explanation below).
- f Cost of power to operate tool, including also lighting and crane service.

How a Machinist Made 3000 p.c. in Twenty Days

How Walter E. Flanders, Machinist, now President and General Manager of the E-M-F Co., a Branch of which is being Established in Walkerville, Ont., turned \$195,000 into \$6,000,000 in Twenty Days.

Walter E. Flanders, left school at fifteen years of age and became a machinist. Later, he dropped the lathe to sell machinery. The risk he ran was nothing compared with the benefits that might accrue if he succeeded. Failure did not figure in his plans. He combined personality with business, and to those to whom he sold his machines, he imparted knowledge of their uses. And Flanders succeeded—**HIS HEART WAS IN HIS WORK.**

It soon dawned upon the machinist, that if he could sell other men's tools he could sell those of his own manufacture. He discerned an increasing demand for certain special machines and machine tools and became a producer. He felt that the great problem in manufacturing was to minimize the cost of production through mechanical means without detracting from the quality of the output, and this was one step towards success.

He then became interested in the automobile business. He mastered the details of construction, the business of direction and the art of organization. As, when in his machinist's days he had selected steel so now he selected men with an eye to quality, strength, temper and durability. In perfecting his organization, **HE PICKED THE RIGHT MEN.**

Flanders has in the E-M-F plant at Detroit, thousands of men at the drills, forges and in the management of the business. All are contented and are helping in the success of the business. He has succeeded in enthusing them in the work and he gives this as a solution **"I LET HIM SHARE RESULTS."**

What Efficiency Will do.

A good example of what enthusiasm on the part of the men and consequent high efficiency on their part will do, is shown in the Detroit, No. 1 plant of E-M-F Co. That particular factory has a capacity of thirty cars a day. A visitor, one quite familiar with the automobile business, discovered in looking

over the institution that sixty-five cars a day were being turned out.

"How do you do this?" he asked somewhat bewildered. "Your equipment calls for thirty cars a day. Yet you turn out more than twice that number."

"I share results with my men. I make it worth while to them in dollars and cents. Every car that leaves this plant for shipment represent a premium to every employe here. It is true that the plant calls for thirty cars per day, but **I AM FORTUNATE IN HAVING A SIXTY-FIVE CAR CREW.**"

This was the condition when a change of salesmanship was made, which resulted in an investment of \$195,000 being turned over for \$6,000,000. The plan of distribution and sale was found to be inadequate and after due deliberations, a change of the selling plan was made by which motor-cars were sold direct from the factory to agents. The following contributed by Flanders formed part of an advertisement inserted in half-page space in the leading city dailies, which brought results from every quarter:—

"A splendid opportunity for hustling young men of good standing, having experience in selling large quantities of automobiles, and with sufficient backing to finance this proposition to form a sales company. The E-M-F Co. will co-operate with you in establishing a permanent business corporation."

Within ten days 1,200 cars were sold, 400 more were ordered and \$1,000,000 had poured into the coffers of the company added to which were \$19,000,000 additional in future orders.

It does not require a mathematician to figure out just what Flander's plunge meant to the E-M-F Co. Let us calculate the value of those forty-six words that he contributed to the advertisement, based on the \$20,000,000 results. In actual money, it figures out \$434,782.60 per word.

This woke up Wall Street. It was business and salesmanship, but it woke up the money market, which two years ago would not advance a dollar on an automobile proposition. Bankers, who previously held aloof, now made propositions to the machinist. He presented his case briefly. His total investment in twenty months amounted to \$195,000; his pay-roll numbered about 12,500, and it was agreeable to him that the probable purchaser instal an expert accountant to go over his books. He was of the opinion that about \$6,000,000 would be sufficient to close the deal and turn over the E-M-F Co. to whoever wished to secure possession of the property, together with what it meant to the future of automobile manufacturing.

The banker, with that foresight which has marked his course in similar large industrial enterprises, considered the Flander's proposition a fair one, and the transaction was closed upon those terms. Thus, the E-M-F Co.'s original investment was turned over in twenty months multiplied thirty-two times.

Secret of Management.

Walter E. Flanders still continues the management of the E-M-F Co. When the deal was put through his assistants received compensation at the rate of eight to one for their stock holdings. He attributes his secret of successful management to "whacking up" with the other fellow, to — **ORGANIZATION PLUS COMPENSATION.**

Geo. Wedlake, of the Cockshutt Plow Co., Brantford, is on a trip to Cuba to further the interests of that company.

A. S. Herbert, manager for Canada of the Siemens Dynamo Works, has returned to Toronto, from the Old Country, after an absence of four months.

J. J. Brooks, Jr., general sales manager of the Harbison-Walker Refractories Co., Pittsburg, has been elected to its directorate.

\$10 For An Idea

For the "Business Management" department of Canadian Machinery.

We want ideas for this department—ideas of practical, labor-saving, cost-reducing value. We will pay at regular rates for each idea accepted, and in addition will pay \$10 for the best idea submitted during the next five months—that is, until Sept. 30, 1910.

Address all communications to the Editor of Canadian Machinery, 111-127 University Ave., Toronto, Ont.

MACHINE SHOP METHODS ^{AND} DEVICES

Unique Ways of Doing Things in the Machine Shop. Readers' Opinions Concerning Shop Practice. Data for Machinists. Contributions paid for.

ATTACHMENT FOR TURNING OVALS.

By J. H. R., Hamilton.

The accompanying sketch shows an attachment, used on a lathe for turning and boring ovals and other shapes as shown. The object of the device is to cause a lateral motion to the tool, while the lathe spindle revolves.

The eccentric E is keyed to shaft S, supported and kept in position by

The lateral motion of the tool must be equal to one-half of the difference between the major and minor diameters. If the major diameter is 3", minor diameter 2½", the motion of the cross slide must be ½".

FLYWHEEL DESIGN.

The accompanying illustrations show a difficulty that was encountered recently in a machine shop and foundry when

casting a flywheel for a Stock Gate for McLaughlin Bros., Arnprior. Fig. 1 shows the flywheel when first designed and Fig. 2 shows the redesigned flywheel when completed.

The flywheel is 6 ft. 3 in. in diameter; A A are 2 in. x 2 in. pins, B is a 3 in. x 1½ in. pin. When the piece was cast the inspector found the casting was broken at C and D, and cracked at E. On account of the metal contracting

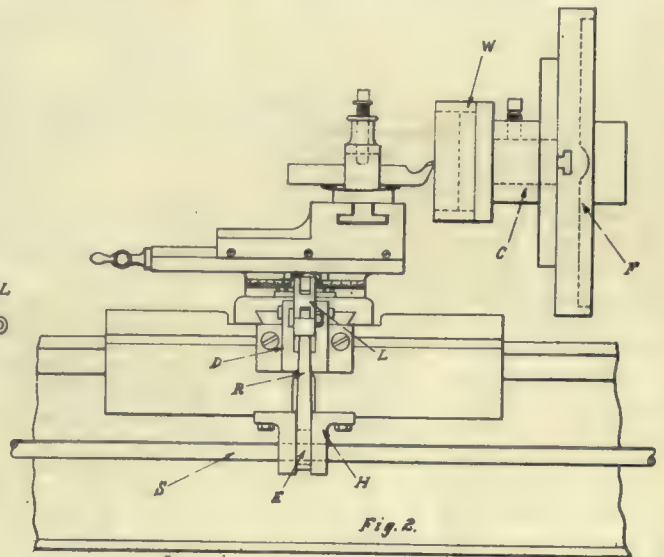
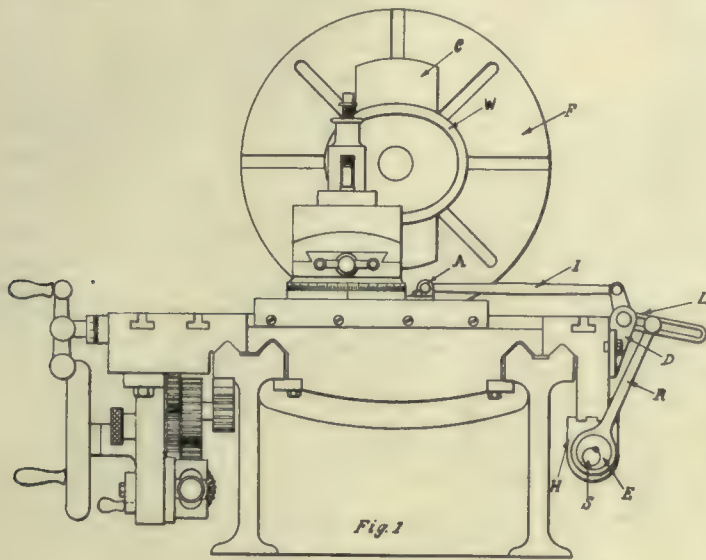

bracket H. Motion is transmitted to the tool through the eccentric H, rod R, bell crank L and rod I; bracket A being secured to the cross slide as shown. The shaft S is revolved by a train of gears similar to the lead screw.

For an oval, shaft S must revolve twice while the spindle revolves once, or a ratio of 2 : 1.

In Fig. 3 the skeleton sketch shows the action of the device.

A represents a 2 : 1 ratio.

B represents a 3 : 1 ratio.

C represents a 4 : 1 ratio.

As the lateral motion of the tool is the same as bracket A, Fig. 1, the skeleton sketch shows the different positions of the tool as the work revolves.

Take the oval for illustration. When the eccentric is in the position 1, the tool is also at point 1; eccentric at 2, tool at 2'; eccentric at 3, tool at 3'.

The index figure as (4'') denotes the tool position for the (") second revolution of the eccentric E.

The cycles of operations in B and C are similar to A, but with different ratio, and should be clearly understood by the sketch. The arrow shows direction of motion of lathe spindle.

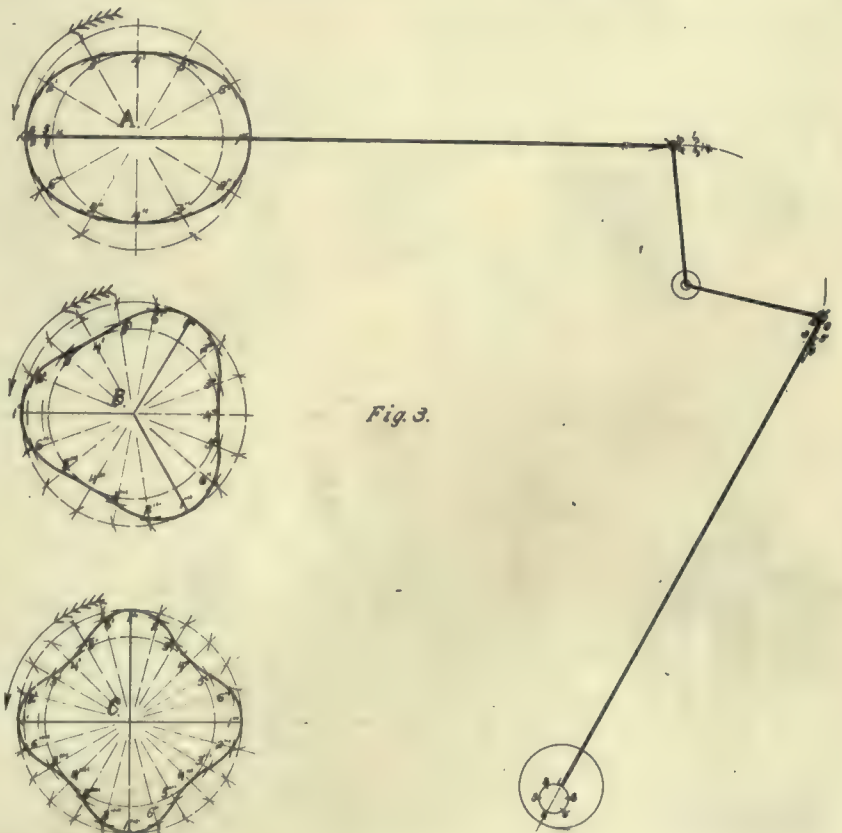

when cooling this design could not be used and Fig. 2 was the second and successful design. The centre arm was eliminated and the pattern slit at F. The two other arms were moved nearer F. The casting was then made without any further difficulty.

were made by John Inglis, Toronto, for McLachlin Bros., Arnprior, and these were equipped with these crank pin oilers.

The oil is fed to the centre hole, a packing nut being provided. The two outer tubes are for the water supply, in-

Cycle and Motor Co. The piece is a good example of multiple die work, the piece itself and all the openings being made at one stroke of the press.

It will be noted that there are eleven openings made in addition to the rather intricate outline of the piece itself. The whole arrangement necessitated some careful punch and die work.

COMBINATION BORING MACHINE.

In the accompanying line cut is illustrated an interesting machine made by modifying a standard type so as to very greatly increase its rapidity of operation for turning out one particular product. This machine is used for boring the guide barrel, facing the flange and boring and facing the main bearings of small engine beds.

As seen from the cut, the boring bar C D, supported in the head carried on the guides H and G at one end and by the frame E at the other end, is boring out the cylindrical crosshead guide, while at the same time, the tool held in the tool block F, is facing off the flange B. While this is going on, the boring bar K, driven by the worm and wheel N M, and the pulley P; on the shaft O, is boring out the babbitted main bearings A. Also, by means of the facing arms L L, facing tools held in tool boxes, one of which is shown at V, are facing off the bearing ends.

In finishing the flywheel, the two parts of the outer rim were fastened together as shown at G. The wheel is cast to allow the insertion of the steel forging shown, on either side of the rim. The steel rod is upset at both ends, heated, put in position and allowed to cool. It shrinks 1-16 inch, thus holding the two parts of the rim closely together and successfully completing a rather difficult task in designing, pattern and foundry work.

ward and outward flow. The water provides cool bearings at all times.

In the illustration 1 is a brass crank arm, 2 is a brass collar, 3 a brass sleeve, 4 a brass nut, 5 a brass nut, 6 a brass ring, 7 wrought iron set screw, 8 wrought iron oil pipes and 9 tap bolts.

COLD PRESS WORK.

A fine piece of cold press work is shown by the accompanying drawing. This is made from steel 3-32 inch in thickness at the works of the Canada

CRANK PIN OILER.

By K. Campbell.

The accompanying illustrations show a crank pin oiler with provision being made for water cooling of crank. It is a sure cure for hot cranks and has been tried out successfully. Recently saw gates



A Fine Piece of Cold Press Work.

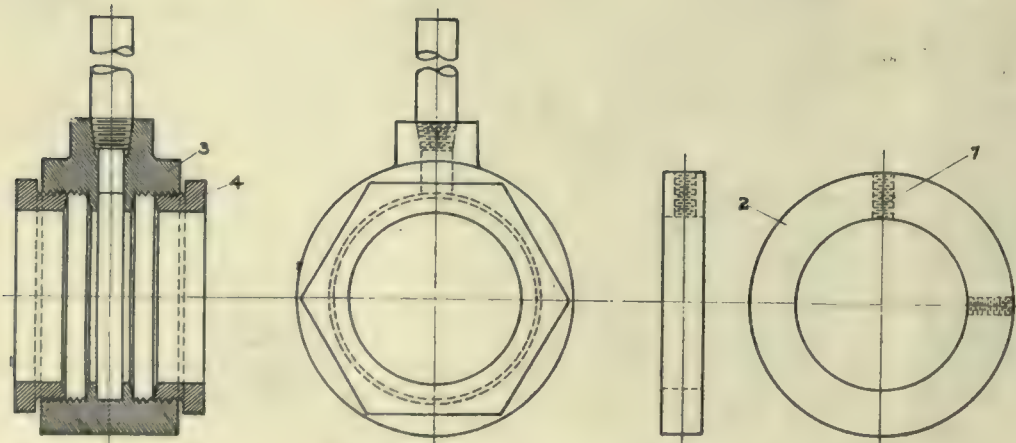
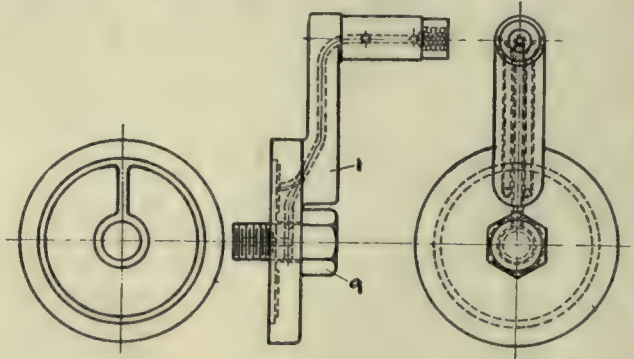
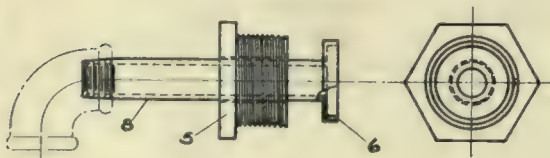

Crank Pin Oiler Cooled by Water Flowing Around the Crank.

The facing tool in the block F, is traversed radially by the star wheel shown at the top of the rotating guide and the facing tools in the blocks L L are also traversed radially by star wheels, one of which is shown at the right. The blocks L L are split, and, by taking out suitable bolts, may be removed from the bar K, to which they are keyed.

and Motor Co., Toronto. The bearing ends, after being babbitted do not present a perfectly smooth surface, and to save re-machining this device is used,

proved a very useful tool for rapidly finishing up these bearings, being much superior to the breast drill which was formerly used.



Facing Tool for Small Bearings.

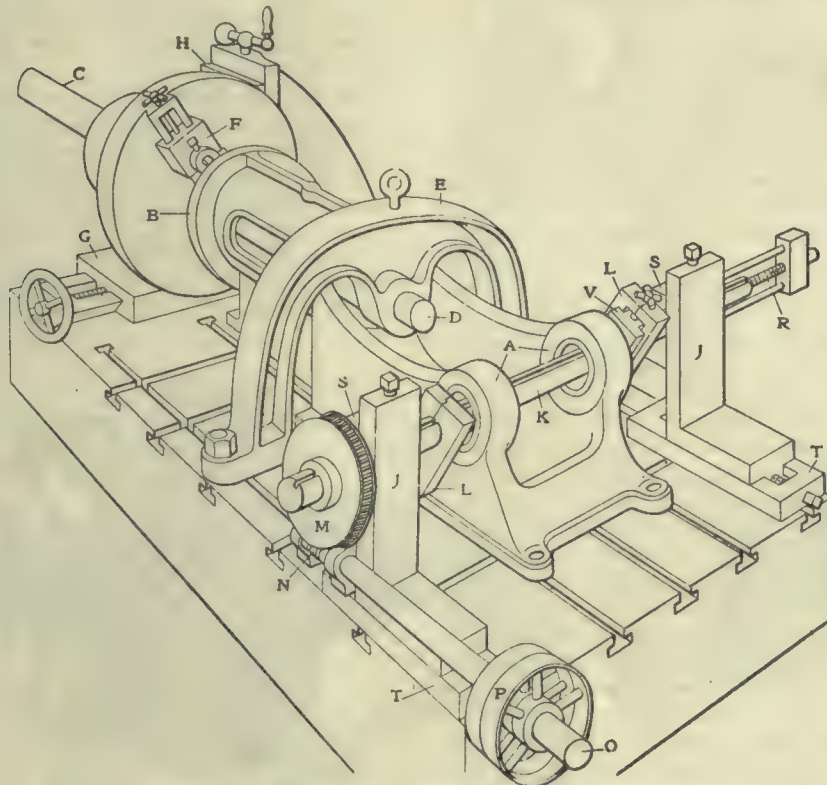

A Combination Boring Machine.

When boring by means of the bar K, the horizontal traverse is given to this bar by the screw R, which is held stationary in the head, at the right. The bar K is threaded internally and, consequently, as it rotates, it must travel along the stationary screw R.

Uprights J J are angle blocks and are adjustable horizontally in the guides T T, the latter being bolted down to the main bed of the machine. By means of the blocks S S, the height of the bar K may be made to suit the work. With these various adjustments, engine beds of a very considerable range in size may be finished with this same machine.

Of course, the near end of the shaft O is supported by a separate bearing which is not shown in the illustration. This machine is in use at the plant of the Newburgh Ice Machine and Engine Co., at Newburgh, N.Y.—American Machinist.

FACING TOOL FOR SMALL BEARINGS.

This tool is made use of to smooth up small babbitted bearings in automobile frames in the works of the Canada Cycle

and Motor Co., Toronto. The bearing ends, after being babbitted do not present a perfectly smooth surface, and to save re-machining this device is used,

TWIN CYLINDER BORING JIG.

This is a handy jig made use of in the shops of the Canada Cycle and Motor Co., Toronto, for both boring and grinding twin cylinders. The finished end of the cylinder casting is bolted to the inside face of the plate A. The main part of the jig is pinned to the lathe face-plate by a pin B, and can be clamped in any position by bolts at CCC. The lathe spindle is hollow and has a rod which fits perfectly at the face plate, and which can be shoved through to fit corresponding holes D or E when the jig is swung into the proper position to engage. By this means exact alignment is readily obtained. To operate one cylinder is bored with pin engaging at D. Then, the pin is removed, jig swung over till it engages at E, and the other cylinder is in position. It provides a ready means for quick production. It is accurate to within one-thousandth of an inch.

The electric operation of trains through the Saint Clair tunnel is showing the same economies, as compared with steam operation, as have been obtained in similar installations elsewhere. According to the Electric Railway

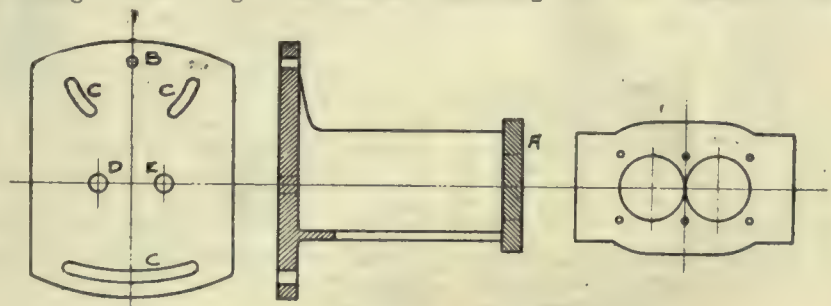

Twin Cylinder Boring Jig.

Journal, the cost of coal for one year under electric operation was only thirty-nine per cent. of that for the last year of steam operation. The total service charges were but sixty per cent. of those for steam, and the sum of service and fixed charges was 84.5 per cent. which represents the operating economy of the new over the old service. The cost of maintenance and repairs for the electric system is fifty-five per cent. of that of steam during the same period.

Journal, the cost of coal for one year under electric operation was only thirty-nine per cent. of that for the last year of steam operation. The total service charges were but sixty per cent. of those for steam, and the sum of service and fixed charges was 84.5 per cent. which represents the operating economy of the new over the old service. The cost of maintenance and repairs for the electric system is fifty-five per cent. of that of steam during the same period.

POWER GENERATION ^{A_ND} APPLICATION

For Manufacturers. Cost and Efficiency Articles Rather Than Technical.
Steam Power Plants ; Hydro Electric Development ; Producer Gas, Etc.

New Jaw and Friction Clutch and "Ideal" Split Pulley

The Positive Clutch and Pulley Works, Limited, Toronto, Have Placed Several Improved Transmission Appliances on the Canadian Market.

THE combined jaw and friction clutch combines the advantage of a friction clutch, to gradually pick up the speed of a driven shaft or pulley, etc., under load, with the positive drive of a jaw clutch. The frictions are not obliged to carry the load, but are used only for the purpose of operating the jaws.

The engaging portions of the jaws narrow slightly to their outer ends and are provided with suitable clearance to eliminate all contact and permit freedom of movement during operation. The springs prevent the frictions and jaws from engaging and disengaging except by movement of the operating lever, but assist in each operation. The friction and jaws operate independently by means of the one lever.

All parts are interchangeable, enabling a coupling or a pulley clutch to be converted to the other, and each to be used on other sizes of shafting. Sleeves are provided with graphite lubrication, and are made to standard diameters to fit the standard bores of pulleys.

The frictions are made of fibre, which prevents them burning. The friction capacity need be only sufficient to pick up the speed of the unloaded shaft or pulley as the jaws when engaged will carry the load which is afterwards applied, up to their rated capacity.

Description of Clutch.

The power shaft is indicated at B, and the load shaft at A. Mounted on the shaft A is a hub C, formed with a flange to which the disk D is bolted. Projecting through a central aperture in the disk D is an annular jaw E. The disk D at its periphery is formed with annu-

lar flange, which incases part of the clutch mechanism. A ring F is fitted within this flange and keyed to it, for rotation, but free for longitudinal movement. The ring has openings at suitable points to receive fibre blocks G, which protrude from the opposite faces of the ring. Keyed to the shaft B is a member H, on which is fitted a sleeve I formed with a flange at its inner end. A series of bolts J are fitted between this flange and a ring at the opposite end of the sleeve. A ring K is mounted to slide on the sleeve I, and the bolts J pass there through, while coil springs on the bolts J bear against the ring K, tending to press the latter outward. The flange of sleeve I and ring K have annular bearing surfaces adapted to engage the blocks G at opposite sides. They are pressed into engagement by means of levers L fulcrumed to the ring at the end of the sleeve I, and links M fitted between the levers L and the ring K. The levers L are connected by links to a sliding collar N, operated by a lever O fitted with a split collar in the usual manner. The collar N slides on a sleeve P, which at its inner end is provided with jaws R. These jaws are adapted to slide in recesses at opposite sides of the member H and the jaw E.

In operation to engage the clutch (see Fig. 1), by means of lever O, the collar N is moved forward along the sleeve P until it comes in contact with member R. This serves to process the flange I and ring K against the friction blocks G, by the toggle action of the levers and links connected to collar N, and to pick up the speed of the load shaft. When the load shaft is approximately brought

up to speed the springs on the bolts J act through the levers and links to engage the jaws R with the recesses in member E and to disengage the frictions. When it is desired to disengage the clutch the reverse takes place. The frictional surfaces are first thrown into contact to relieve the jaws of the load and the springs then act in like manner to disengage the jaws and then the frictions. The frictional engagement is only momentary and the transfer of the load is almost instantaneous.

Ideal Split Pulley.

The split pulley manufactured by the Positive Clutch & Pulley Works, Limited,

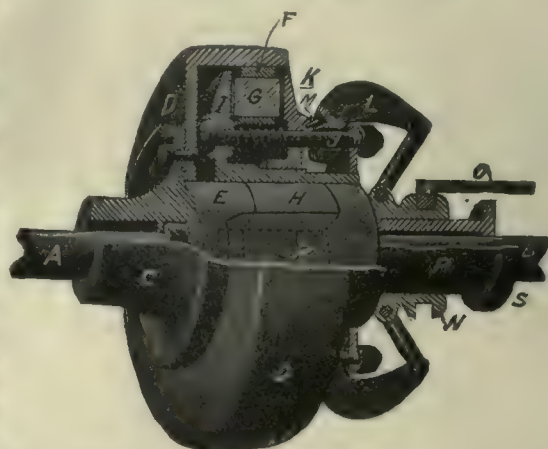

Fig. 1.—Section of Clutch Showing Essential Parts.

ed, 11-13 Jarvis St., Toronto, has a wood rim, steel arms and malleable hub. A test of "Ideal" combination arm pulley 36" diam., 8" face was made in the mechanical laboratory of the S.P.S., by W. W. Gray. It transmitted 20 h.p. at 100 r.p.m., being the rated maximum power of an 8" double leather belt, based on a belt pull of 90 lbs. to the inch. The "Ideal" pulley consumed 1409 watts with sides uncovered and 1405 with sides

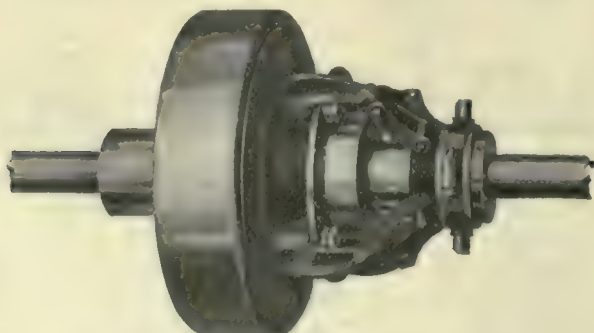

Fig. 2.—As it Appears in Service When Disengaged.

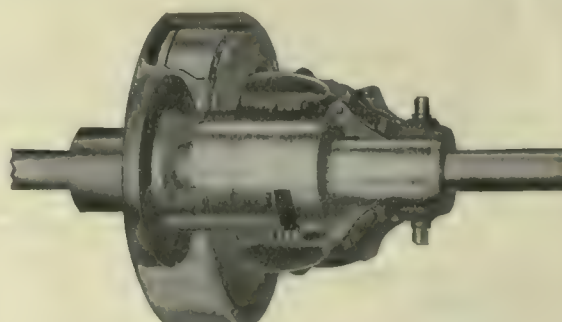

Fig. 3.—Showing the Position of the Jaw Parts and Friction.

covered. The windage was 4 watts or .005 h.p.; the weight and balance was 27 watts or .036 h.p. The test was performed with shaft running at 400 r.p.m. at which speed the watts consumed to run shaft free of pulleys was 1378 watts.

Construction of Pulley.

The rim is made of well-seasoned maple thoroughly kiln dried, each segment being nailed and glued to the adjoining segments. The arms are made of cold drawn seamless steel tubing, pressed into a ribbed form under enormous pressure.

The hub is made of malleable iron with a number of bosses ribbed together to impart strength and reamed out to receive the arms. The bolt holes are cored to fit the heads of the bolts, to prevent the bolts from turning. The bushings are made of cast iron and provided with sufficient bearing to prevent them slipping in the pulley or on the shaft. The bushings are interchangeable.

The arms are connected to the rim by means of saddle plates which are squeezed over the flattened ends of the arms and are fastened thereto, also to the

the arm before being forced into the hub; 4, the hub connection showing the manner in which the arm is secured; and 5, the bushings showing the large area of contact with the hub and the shaft.

TEST OF STEAMER LEVIS.

The first production by the Canadian General & Shoe Machinery Co., of Levis, Que., in their new departure in engineering lines, is the steamer Levis, built for the Levis Ferry Co., Ltd., tested April 27, 1910, at Quebec. This firm built the machinery while the hull was constructed by the firm of Davie & Sons, also of Levis. The test of the steamer proved quite satisfactory, the machinery running smoothly, with little vibration. The steering gear proved to be remarkably sensitive, everything showing careful design.

A notable feature about the ship was the great expediency of its construction, for the contracts, for it and its sister

Director, Ernest Caron, in 1901, for the sole purpose of manufacturing shoe machinery. That field not proving sufficiently extensive, the works of Carrier, Laine & Co., in Levis were leased from the Federal Government for a term of 30 years, and the old plant moved across the river to this newer place, where a general engineering business is now carried on. In their new premises, the firm is well situated for the rapid and efficient production of all kinds of machinery.

WESTERN CANADA RAILWAY CLUB.

In his recent annual report, W. H. Rosevear, the secretary of the Western Canada Railway Club, Winnipeg, claimed that no railway club on the American continent had grown so quickly as had the Winnipeg organization. The membership of the society increased from 35 to 450 in one year. Officers for this year were elected as follows: Hon. president,

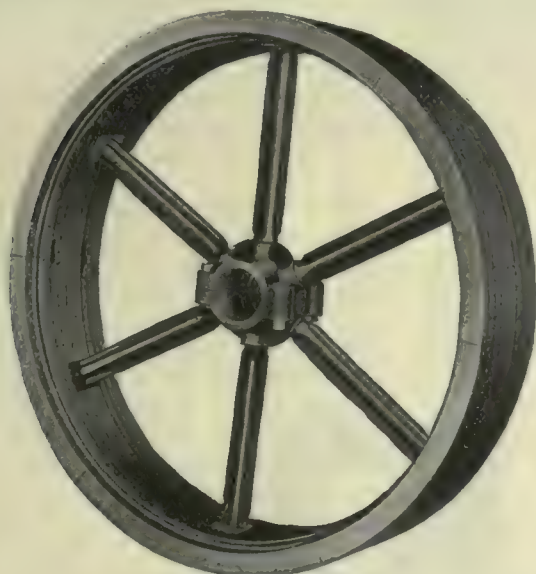

Fig. 4.—"Ideal" Split Pulley.

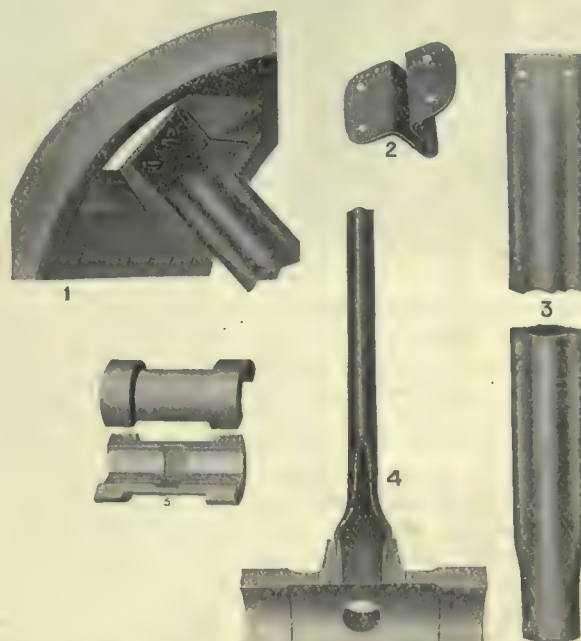

Fig. 5.—Parts of "Ideal" Split Pulley.

rim, by means of stout pins driven through the saddles and arms and into the rim across the face of the pulley. The ends of the saddles are fastened to the interior of the rim.

The arms are connected to the hub under enormous pressure. They are forced inwardly on a taper, expanded outwardly at their inner ends and upset at the extreme outer ends of the hub bosses, thus making perfect connections without the use of rivets or screw threads.

Fig. 5 shows the parts of the "Ideal" combination split pulley, which is patented in all countries. In this figure, 1 illustrates the rim connection showing saddle and pins; 2, the saddle plate; 3,

ship, Lauzon, which is nearing completion, were only let November 25, last. These two boats are for summer traffic; but the contract for two winter boats has been let to the same firms, on the recommendation of the supervising naval architect, A. Angstrom, of Toronto. These latter boats are to be delivered next November.

The companies interested are worthy of comment. The hull builders, Messrs. Davie & Sons are an old established firm, having been in business in Levis some 25 years. The Canadian General & Machinery Co., Ltd., who built the engines and boilers and installed the same, is a newer concern, having been established in Quebec by its managing

Wm. White, (second vice-president of the C.P.R.); hon. vice-presidents, E. J. Chamberlain (vice-president and general manager of the G.T.P.), G. J. Bury, (general manager of the C.N.R.), and W. Phillips, (general manager of the Winnipeg Electric Railway); president, A. E. Cox, first vice-president, G. W. Caye, second vice-president, R. R. Neild; secretary, W. H. Rosevear; treasurer, E. Humphries. The executive committee was selected as follows: Grant Hall, J. Hillis, S. J. Hungerford, J. G. le Grand, F. H. Crane, W. S. Fallis, E. W. du Val and L. O. Genest. A. H. Mulcahey and E. O. Balleine were made to form the audit committee.

DEVELOPMENTS IN MACHINERY

New Machinery for Machine Shop, Foundry, Pattern Shop, Planing Mill; New Engines, Boilers, Electrical Machinery, Transmission Devices.

MICROMETER CALIPERS.

The Brown & Sharpe Mfg. Co., of Providence, R. I., have recently added to their line of Micrometer Calipers a new series that will measure all classes of work from one to 12 inches and from 25 to 300 millemetres.

The micrometers embody the new style of frame recently adopted and which is a distinctive B. & S. feature. This is made with an I section that tends to strengthen the frame at the very points

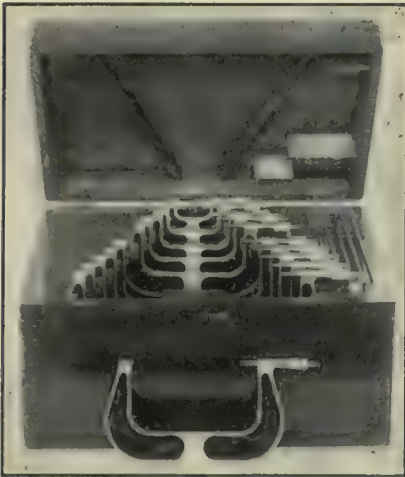

Micrometer Calipers, Brown & Sharpe.

where strength is needed, to give rigidity to the whole tool, and also to lighten it so that it is convenient to handle.

Although the frame is lightened it does not interfere with the accuracy of the tool, each of the micrometers being rigidly inspected for accuracy before they leave the shop. All of the parts that are subject to wear are hardened and means of adjustment are provided to compensate for wear. A standard gauge for testing the accuracy of the micrometer is sent with each one.

Another feature that still further enhances the value of the tool is the fact that the measuring points are left square to aid in measuring small projections on a plane surface.

These micrometers are furnished singly or in sets, the full line of eleven micrometers in one set and six sizes in the other.

RADIAL DRILL.

The illustration shows a new design 4 ft. and 4½ ft. Radial Drills, brought out by the Mueller Machine Tool Co., Cincinnati, to meet all the requirements of modern drilling. Strength and massiveness are exhibited in every part of the machine. The column is of heavy

construction, insuring rigidity. It is well ribbed internally and ground to size. The arm is of hollow rectangular section and has been increased considerably in weight. It can be securely locked to the column by the one tightener handle shown. This is convenient for the operator as he does not have to bother with two handles. The arm can be raised and lowered by a coarse pitch screw, conveniently controlled. It can be lowered at twice its elevating speed.

The head has been strengthened, and is traversed on the arm by a rack and pinion. It can be locked to the arm by two small tightener handles. Our back gears are located on the head and the operating handle is located in front of the operator, making it very convenient. They are of simple construction and may be engaged or disengaged without the slightest shock while the machine is in motion. The tapping mechanism will take care of unusually heavy tapping operations without showing a strain. It has a device to prevent breaking of taps, and also permits taps to be backed out at accelerated or even speed. The handle for starting, stopping, and reversing the spindle is located on the head in front of the operator.

Spindle is equipped with a depth gauge and automatic stop, and twenty-four changes of speed are available. All speeds are given on a brass plate attached to the arm of the machine. Spindle is

counterbalanced and has quick advance and return. The machine is furnished with a combination positive and friction feed and arranged for eight changes to each change of spindle speed, any one of which is instantly available without stopping the machine.

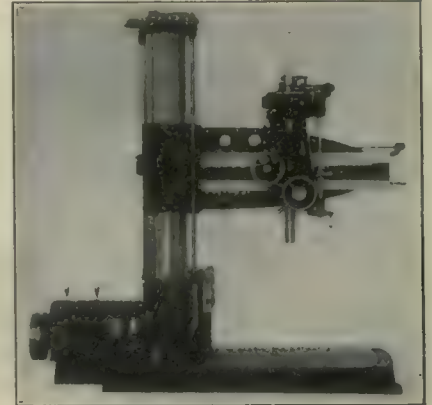

New Radial Drill, Mueller Machine Tool Co., Cincinnati.

The speed-box is of the geared friction type and permits twelve changes of speed. Changes are made by moving the without the slightest shock.

NEW PLANING MACHINE DRIVE.

For some years engineers have been trying to develop systems to improve the driving of reciprocating machine tools, such as planing machines. In about 1902 Electro Magnetic Clutches were tried and now a very large num-

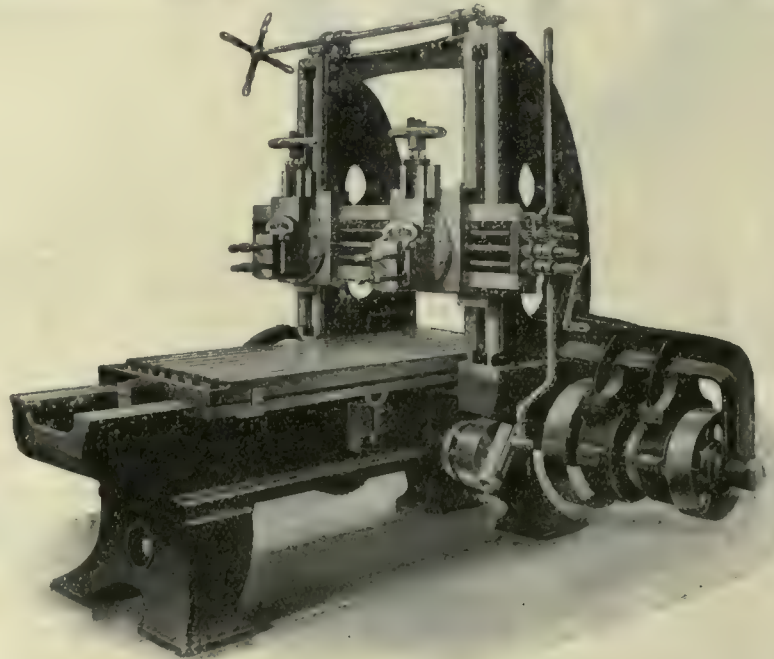

Planer, C. E. Luard & Co., Chester.

ber have been installed with great success. Planers from 2 ft. 6 in. by 5 ft. up to 9 ft. by 35 ft. are now running and giving every satisfaction. C. E. Lugard & Co., of Chester, have put this system on the market under the name of the S. M. Electro Magnetic Drive.

shaft, but capable of sliding end ways, fitted with a renewable cone of hard fibre. As soon as the circuit is closed the 2 parts of the armature re-sucked together by magnetic attraction, the drive being partly magnetic and partly frictional.

An air gap is always maintained be-

MULTI-SPEED PLANER.

A new multi-speed planer operated by a four speed belt variator has been placed on the market by the American Tool Works Co., Cincinnati.

The four speeds are obtained through a pair of opposed four step cone pulleys operated by an endless belt between

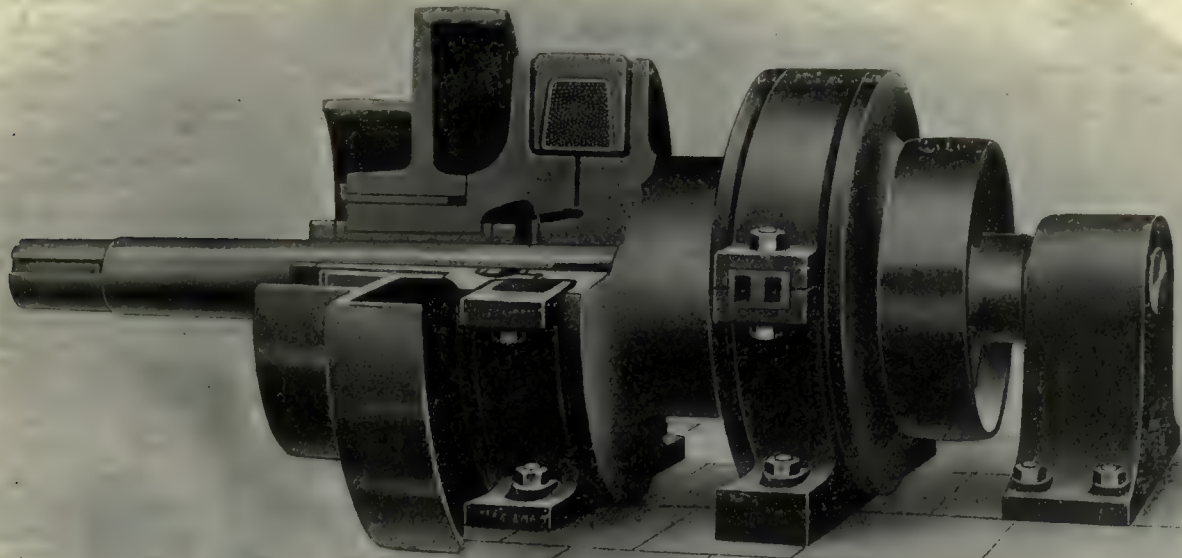

New Planer Machine Drive, C. E. Lugard & Co., Chester.

Many engineering shops have in their works what is now considered an old planing machine, built perhaps 10 or even 15 years ago, but strong and capable of doing good work. Such a machine cutting at 25 ft. per minute resting for $3\frac{1}{2}$ seconds for the belt to come over and returning at 35 ft. per minute, which if fitted with a Magnetic Drive can be speeded up without any damage to the machine to give two cutting speeds of say 28 ft. per minute for cast iron and 50 ft. per minute for steel or brass, with no appreciable rest at the end of the stroke, and a return of 100 ft. per minute or more, thus giving at least $2\frac{1}{2}$ times its former output. The conversion is carried out by replacing the shaft carrying the 3 belt pulleys, the quick return sleeve and pinion, by a shaft carrying a double S.M. Electro Magnetic Clutch fitted with pulleys. The old striking gear is replaced by a two-way switch.

Fig. 1 shows an S. M. Electro Magnetic Reversing Shaft, fitted for two cutting speeds and a constant return speed. The clutches each consist of a stationary magnetic body containing a coil, a divided armature, one part running loose on the shaft between two collars, and carrying the pulley, the other part secured by a feather on the

tween the stationary magnetic body and the revolving armatures, also the two parts of the armature only engage through the medium of a non-magnetic body so that sticking from residual magnetism is impossible.

The chief advantages claimed for this system are: (1) No shifting belts; (2) Constant speed for any length of cut; (3) Accurate reversal; (4) Simplicity of apparatus and electrical gear. It will be noticed that owing to the stationary magnet no slip rings or brushes are required, and the drive can be installed as well from an existing line shafting as a motor.

Three methods are put forward of utilizing the drive, an open and cross belt direct from the line shafting, the clutch shaft being connected direct to the planer, open and cross belts, the clutch being mounted on a countershaft and connected to the belt pulley of the planer by a short belt, and a gearing drive through the ordinary 5 wheel change connected direct to the planer and motor. It must not be supposed that the system is only applicable to old machines, new planers have been fitted with it at a low cost. Clutches of 1,200 and 1,400 h.p. at 200 r.p.m. have been supplied for rolling mills, as a protective device against overload.

them, the whole being mounted upon a substantial platform on top of the housings. The belt is shifted from step to step and provides a range of speeds calculated to cover the most exacting requirements. These, with the constant high speed return of the platen, insure the greatest working economy.

The drive has primarily two distinct advantages, viz.: simplicity of design and freedom from destructive vibration.

The shifting of the belt is novel and very effective. A pair of belt forks are moved alternately along guide rods by means of a pair of cylindrical cams, which revolve alternately through the medium of a set of intermittent gears operated by the hand wheel shown at rear. One revolution of this wheel shifts the belt from one step to another and a shot pin indicates the complete revolution. The cam rolls have spiral slots milled in their peripheries, each belt fork being moved along the guide rods through the medium of a roller operating in the spiral slots. The relation between the cams and forks is such as to shift the belt off of the high step of one cone before placing it on the high step of the opposing cone.

The tension of the belt is controlled by the vertical lever shown at the rear, operating in a radial slot. This lever is

of convenient height and operates a pair of bell cranks through link connections. The bell cranks serve as levers to slide the "driven" cone towards the "driver" thus slackening the belt. This feature,

lever is securely clamped by the binder handle shown.

The driven cone being moved towards the driver, which latter carries the planer driving belts, is a distinct fea-

to a minimum all shocks to the driving mechanism due to intermittent cutting and at reversing, also insuring a steady even pull at the cutting. They are perfectly balanced, running without the least vibration even on the highest speeds. This, coupled with the smoothness of the drive, the scientific design and accuracy of the planer itself, insures a finished job which is free from imperfections, requiring the least, if any, attention from the vise hands in fitting.

Cutting speeds can be arranged suitable to individual requirements, but are regularly furnished to provide 20 ft., 30 ft., 40 ft. and 50 ft., with a constant return speed of about 80 ft.

Belt drive is regularly furnished with this variator, the tight and loose pulleys being applied to the rear cone shaft. The drive can be obtained direct from a line shaft provided same has a sufficient speed, but slow shafts of about 150 r.p.m., require an intermediate or "jack" shaft. With our construction it is a simple matter to convert the belt drive into a motor drive at any time after the machine is installed.

A constant speed motor is required, either of the direct or alternating current type. The motor is direct connected to the variator through spur gearing. A starting box is all the controlling mechanism necessary. Should the motor at any time become disabled, the driving gear on end of variator shaft may be replaced by a pulley, and the planer driven by belt from a countershaft or another motor conveniently placed.

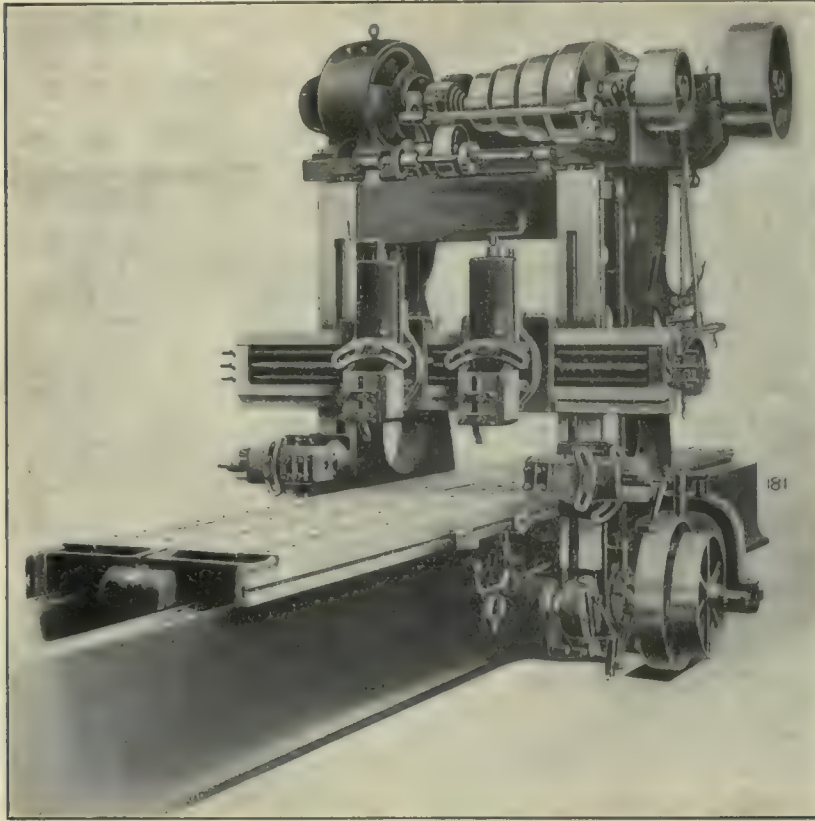

Planer of the American Tool Works Co., Cincinnati.

together with the mechanical belt shifting device and the fact that the steps of the pulleys are beveled on the edge, so as to offer no resistance to the passage of the belt, permits of easily mak-

ing rapid changes of speed, even though the belt is very wide. After the belt is located for the desired speed, it is brought up tight by moving the hand lever to the point where tension is sufficient for the work, after which the

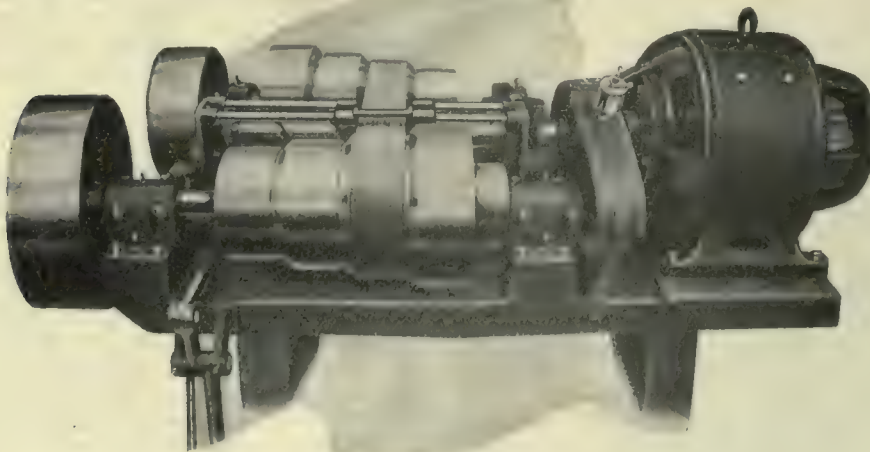

Planer Drive, The American Tool Works Co., Cincinnati.

ing rapid changes of speed, even though the belt is very wide. After the belt is located for the desired speed, it is brought up tight by moving the hand lever to the point where tension is sufficient for the work, after which the

Speeds are changed without stopping. This is a valuable feature of this drive. With this drive it is far easier to make the changes while in motion than otherwise. Driving pulleys have fly-wheel rims, the momentum of which reduces

MACHINE TOOL BUILDERS.

The eighth annual convention of the National Machine Tool Builders' Association opened at Hotel Seneca, Rochester, on May 24. Over one hundred representatives of machine tool manufacturing concerns being in attendance. Papers were read on Cancellation of Orders, Cincinnati Continuation School, Future of the Automobile Business with Reference to Machine Tools, Cone Drive vs. Gear Drive, etc. Committees reported on Apprenticeship, Uniform Costs, and Standardization of Motors.

It is announced that W. A. Bowden, designing engineer of the Department of Railways and Canals for the last five years, has been appointed chief engineer of the department. He is a graduate of McGill, was appointed by M. J. Butler some five years ago, and has done good work. He designed the new Intercolonial Railway shops at Moncton, New Brunswick.

Stephen H. Chapman, president and general manager of the Ontario Wind Engine & Pump Co., Toronto, is traveling through Western Canada in the interests of the firm.

CANADIAN MACHINERY

AND MANUFACTURING NEWS

A monthly newspaper devoted to machinery and manufacturing interests mechanical and electrical trades, the foundry, technical progress, construction and improvement, and to all users of power developed from steam, gas, electricity, compressed air and water in Canada.

The MacLean Publishing Co., Limited

JOHN BAYNE MACLEAN, President W. L. EDMONDS, Vice-President
 H. V. TYRRELL, Toronto Business Manager
 G. C. KEITH, M.E., B.Sc., Toronto Managing Editor
 F. C. D. WILKES, B.Sc., Montreal Associate Editor

OFFICES:

CANADA	UNITED STATES
MONTREAL - Rooms 701-702 Eastern Townships Bank Bldg	NEW YORK - R. B. Huestis
TORONTO - 111-127 University St. Phone Main 7524	1109-1111 Lawyers' Title, Insurance and Trust Building
WINNIPEG, 511 Union Bank Building Phone 3736	Phone, 1111 Cortlandt
BRITISH COLUMBIA - Vancouver F. R. Munro	FRANCE
Room 21, Hartney Chambers H. Hodgson,	PARIS - John F. Jones & Co.,
GREAT BRITAIN	31bis, Faubourg Montmartre, Paris, France
LONDON - 88 Fleet Street, E.C. Phone Central 12960 J. Meredith McKim	SWITZERLAND
	ZURICH - Louis Woll Orell Fussli & Co.

Cable Address:

Macpubco, Toronto. Atabek, London, Eng.

SUBSCRIPTION RATE.

Canada, United States, \$1.00, Great Britain, Australia and other colonies 4s. 6d., per year; other countries, \$1.50. Advertising rates on request.

Subscribers who are not receiving their paper regularly will confer a favor on us by letting us know. We should be notified at once of any change in address, giving both old and new.

Vol. VI.

June, 1910

No. 6

PROGRESS OF CANADIAN TRADE.

Since Confederation to date the statistics of Canadian trade have indicated the curious fact that the crests of each marked wave of trade expansion have followed each other in cycles of almost ten years.

Commencing in 1873, all previous records were broken with a total trade of a little over \$131,000,000. In 1883 a new high record of over \$230,000,000 was established; and in 1893, the third marked expansion and new high record of over \$247,600,000 was attained. No halt in the trade followed until the new high record of over \$472,700,000 was reached in 1904. A temporary halt was experienced in 1905 and again in 1909, but 1910, when the figures for that fiscal year are announced will show it to have been the greatest in the history of Canada.

Canada started off the first month of the present fiscal year with a gain of nearly eleven million dollars, or 31 per cent., in her total trade, as compared with the total trade for April of last year. Imports for the month totaled \$30,682,438, an increase of \$8,150,765, or about 36 per cent., as compared with the corresponding month of last year.

Exports of domestic products totaled \$14,502,681, an increase of \$2,644,884, or about 22 per cent. Exports of agricultural products for the month totaled \$6,061,072, an increase of a little over one and a quarter millions. Exports of manufactures totaled \$2,380,011, an increase of \$632,011.

If the present rate of increase is maintained for the rest of the year the total trade of the Dominion will considerably pass the eight hundred million mark. The customs revenue for the month was \$4,883,015, an increase of \$1,094,555.

PROTECT BELTING AND MACHINERY.

Caught on the belting of the machine at which he was working, and carried along against the floor above where his body lodged, while the shafting pounded him into insensibility, W. A. Gon met a horrible death in the concentrating mill at Eustis. Gon was an employe of the mill, and was busy at his work, when his clothes accidentally caught on the belting, which carried him off his feet.

After being whirled with lightning rapidity through a sixteen-inch space between the belting and the ceiling over some machinery in the mill at Greer's camp at Mack's Siding until every particle of clothing was torn off him, Daniel McCullough now lies in St. Joseph's hospital with his right leg broken and one shoulder badly shattered, fortunate in having escaped with his life.

Canadian Machinery has pointed out on numerous occasions the necessity of protecting belting and machinery. Unless moving parts, belting, etc., are properly protected, by caging, fencing or in any convenient but effective manner, employes are in constant danger. We do not know whether or not the accidents here described are due to carelessness on the part of the men or the companies, but we believe it is to the interests of companies generally, to look after the physical well-being of the engineers and employes. By protecting the workmen from possible accidents they are kept always at work and there is no danger of such reports being published as those here given.

NEW QUEBEC BRIDGE.

The new Quebec bridge will be of cantilever design and tenders will be called for by public advertisement in the leading engineering journals of Canada, U. S. and Great Britain in the course of a few days. The Minister of Railways received a cable recently from Engineer Fitzmaurice, who is now in England, stating that after consultation with his colleagues, Modjeska and Vautelet, the other members of the board of experts appointed by the Government to supervise plans and construction of the new bridge, they had agreed that the tests which have been recently made, both in England and the United States, as to the suitability of the cantilever design submitted last fall by the Board of Engineers showed that it was the best possible. Tests have also been made of the suspension design, but the engineers have decided in favor of the cantilever. About three months' time will be given for tenders to be submitted, and all tenders must comply with the condition requiring a sufficient guarantee that the bridge will be constructed strictly according to specifications, and that in case of any failure, the contractor will be liable for all loss.

THE MAN WHO DOES.

To-day the man who *does* is the only one who is recognized.

What he has been or what he has done—

What he expects to do in the future—all these make a pretty story.

But we like the sound of the footsteps of the man with red blood in his veins—

The man with fire in his eyes, energy in his movements.

Not a man who *expects* to do—some day,
 But the man who is doing things—*now*.

—Obermayer.

FOUNDRY PRACTICE AND EQUIPMENT

Practical Articles for Canadian Foundrymen and Pattern Makers, and
News of Foundrymen's and Allied Associations. Contributions Invited.

WADSWORTH CORE MACHINE.

For a number of years George H. Wadsworth, of the Falls Rivet & Machine Co., Cuyahoga Falls, has presented the foundry public with a new type of core machine each year, and at the coming convention in Detroit he will have on exhibition a new and interesting type known as the Wadsworth Vertical Jar-Ramming Core Forming Machine.

This is clearly illustrated in the accompanying views. The mechanism is shown in Fig. 1. The machine consists of a table supported upon suitable legs between which the operating mechanism is situated. The core is formed in a vertical shell or core box, sand being supplied from the swinging hopper above the machine. As the sand is fed into the core box or shell the crank at the right is slowly rotated so that the ratchets upon the shafts at each side of the centre of the machine alternately lift and drop the core box or core tube. The stool which supports the entire mechanism for forming the core has pro-

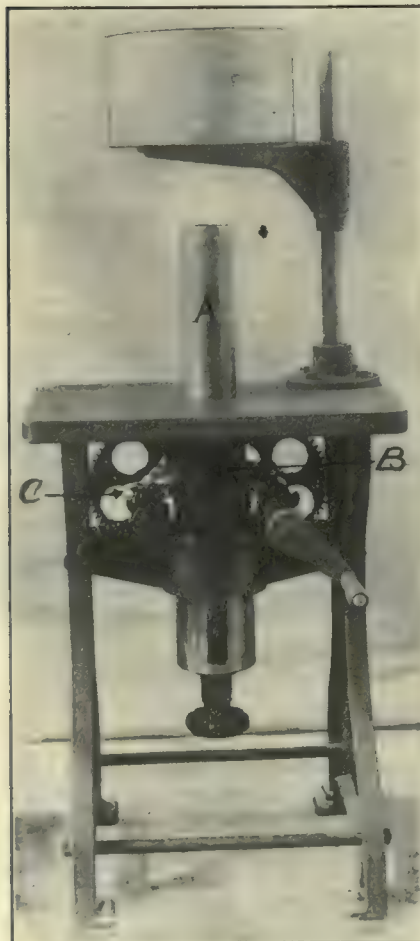

Fig. 1.—Wadsworth Moulding Machine Showing Mechanism.



GEO. H. WADSWORTH.

Falls Rivet and Machine Co., Cuyahoga Falls.

jected from it wings in the form of pawls. These wings rest on two ratchets, so that the mechanism is lifted from both sides at the same time. The ratchets are kept in proper position by the gears seen at the back of the machine. The core tube A works in a sleeve B, and is controlled by the adjusting screw C. This screw is first adjusted as to the proper length of core to be made and then the tube forced through the table of the machine by lifting the adjusting screw and turning it into the groove at one side of the vertical slot as shown.

For making an ordinary straight core the straight tube itself is all that is necessary. For irregular cores special dies or core boxes are introduced on the inside of the tube A, and the jarring motion of the machine compacts the sand into the box, causing it to feed out under the shoulders of chambered cores. A group of cores made in this machine is shown in Fig. 2. At the rear are shown straight cores and cores with tapered prints on one or both ends.

The front row contains a number of chambered cores. The core at the left is not only chambered but provided with tapered prints at both ends. The large diameter is $2\frac{1}{4}$, and the main body of the core two inches. The difference in diameter between the various parts of the other cores is plainly shown. A group of the machines which will be shown at Detroit can be seen in Fig. 3. In this illustration all of the dies have been drawn down through the tables. In

the three machines at the left the vent rods have been drawn and are lying on the table, while in the three machines at the right the vent rods are in place. At the left of the central spindle of several of the machines can be seen the bushing which is placed in the top of the die to form the upper tapered print. At the right of the central spindle on three of the machines can be seen the split core box or special die which is introduced into the machine for forming chambered cores.

The lower end of these die-boxes is tapered in such a way that when the outer casting or tube is drawn down through the table of the machine the dies fall away automatically, leaving the core standing upon the lower stool.

Fig. 4 shows the machine after the cores have been formed. The two cores at the left each have tapered prints top and bottom, and in the illustration the lower tapered print is standing in the lower die. These cores are turned over onto a former or drier which is placed against the side of the core, while it is still in a vertical position. After the core is turned over the bushing forming the lower tapered print, and which also acts as a stool, is withdrawn from the sand. On the third machine from the left is shown a straight or parallel core. The three machines at



Fig. 2.—Set of Cores.

the right all show chambered cores. These also have to be turned on to special driers or pans. Cores with tapered prints can also be dried on end standing in the stool which forms the lower part of the die on the machine. These stools are exceedingly simple in construction and can be made in quantities on an au-

automatic screw machine so that they furnish very convenient core pans.

The machines with all of the dies in place ready for ramming cores are shown



Fig. 3.—Wadsworth Machines to be Shown at Detroit.

in Fig. 5, and it will be noted that the vent rods project above each one of the dies, thus insuring a clear vent through the entire length of the core. The vent rods are drawn up out of the cores before the dies are stripped down. In the case of the three machines shown at the left the stripping of the tube or die through the table of the machines leaves the upper thimble for forming the upper tapered print standing on the core. This is picked off by hand and is shown at the left of the machines in Fig. 4.

The mixtures for use on this machine have to be somewhat different from those employed in the screw type of core machine. In general, these mixtures approach more nearly those used in multiple core boxes in turning out work by hand. Any good grade of core oil can be used as well as linseed oil, and a considerable portion of old core sand could be introduced into the mixture. Mr. Wadsworth has found the best results are obtained when the batch is made in one of the Wadsworth mixing mills, as the grinding action of the rolls improves the bond in the sand. In the



Fig. 4.—Wadsworth Machines After Cores have been Formed.

general practice in his own foundry Mr. Wadsworth is using a black core compound as the principal binder. For wetting down he is using glutrin, and he

has experimented with several different grades of linseed oil and core oil, all of which have given very fair satisfaction.

UNITED STATES AND CANADIAN FOUNDRIES.

A census of the foundry industry of the United States and Canada made by

census in 1906 showed 6,108, so that the net increase in four years is 486. In compiling the figures each plant was regarded as a unit, though there might be several departments. Counting each foundry department as a unit—there being many cases where gray iron and brass foundries are operated by one company, sometimes with a connected malleable or steel foundry—the total for the United States and Canada is 9,158. The total number of foundries producing gray iron castings is 5,157, as compared with 5,105 in 1908 and 4,956 in 1906. The plants melting non-ferrous metals exclusively, including brass, bronze, aluminum, etc., number 1,240, against 1096 in 1908, an increase of 144. Brass foundries operated as departments of works number 2,318, making the total number of brass foundry operations 3,558. The number of foundries making castings into which aluminum enters is found to be 1,679. The increase in malleable and steel foundries is noteworthy. The total number of malleable castings plants is now 178, of which 168 are in the United States. The total for the United States and Canada in 1908 was 153. The number of steel foundries is 265, against 211 two years ago.



Fig. 5.—Machines Ready for Ramming Cores.

The Foundry shows a total of 6,594 foundries on April 1, 1910, against 6,366 in 1908, a net increase of 228. A similar

CENTRAL RAILWAY CLUB.

The regular monthly meeting of the Central Railway Engineering Club, Toronto, was held on May 17. J. Jay Dunn, chief engineer of the Shelby Steel Tube Co., Ellswood City, Pa., gave an interesting paper on "Seamless Steel Tubes." He described the manufacturing processes and the properties of steel tubes.

It was decided that the annual club picnic will be held at Beaverton Beach on June 18. A special C.N.R. train will convey the club and friends to Beaverton Beach. President Duguid occupied the chair.

Lawrence L. Anthes, of the Anthes Foundry Co., Toronto, is home from a business trip through Western Canada.

Annual Convention of Foundrymen at Detroit, June 6 to 10

The 1910 Convention of Allied Foundry Associations at Detroit Promises to Eclipse all Previous Conventions—Canadian Foundrymen Should Attend.

Preparations by the Detroit committee for the coming convention of the American Foundrymen are being made with the view of having everyone who attends this convention, leave "the city where life is worth living" with the remark "this convention is the best yet."

To further the plans and to assure the proper entertainment of the ladies accompanying the members, a dinner will be given at the Fellowcraft Club on Monday evening, May 16th, for the committee, chairmen and members of all local committees, together with their wives, to discuss ways and means to further the plans for this part of the entertainment.

In the reception and entertainment work for the convention the Detroit ladies will occupy a prominent position, particularly at the time of the theatre party and the automobile ride around the city which will be given for the visiting ladies.

The programme which will be gotten up will be full to overflowing of just the proper information to aid the visitors in getting around the city and enjoying the sights to the very best of advantage, and will in itself be a souvenir worthy of being taken home and placed among the treasures of happy days.

Some unique features and surprises are promised by the chairman of the



ARTHUR M. WATERFALL, DETROIT,
President A.F.A., Detroit Foundrymen's Assoc.
and Local Convention Comm.

entertainment committee at the smoker to be given on Tuesday evening of the convention.

Every means is being used to create the proper enthusiasm among the local Foundrymen, and to this end a dinner will be given on Thursday evening, May 19th, by the Detroit Foundrymen's Association, to which every Foundryman in Detroit, together with all those identified with the foundry or supply interests in any way is bidden. It is hoped at this dinner and meeting, which will be followed by a lecture with lantern slide pictures, that many ideas and suggestions may be brought out which will aid in the good work.

Chairman F. T. F. Stephenson delivers a lecture on Saturday evening, May 14th, before the Foundrymen's Association in Cincinnati.

Secretary C. E. Hoyt, of the Foundry and Manufacturer's Supply Association is in Detroit, and will remain there, except at short intervals in Chicago, until after the convention. He has already 30,000 square feet of space sold, for the exhibits, and all indications point to the banner convention of the association.

Dr. Richard Moldenke, secretary of the American Foundrymen's Association, will be in the city on Monday, May 16th. He will deliver a lecture with lantern slide pictures before the Pittsburgh Foundrymen's Association on June 2nd or 3rd.

Vice-President Eugene W. Smith, of the A.F.A., also President of the Foundry Foremen of America, recently organized a Foundrymen's Association in St. Louis, and we are advised that 40 of their members will arrive in Chicago on Sunday, June 5th, and will come from there on the special train with the Chicago delegation.

The Commandant of the United States Navy Yard of Brooklyn, has expressed a desire to send his Foundrymen, together with an officer to the Detroit Convention, and a cordial invitation has been extended to have these people present.

The Sessions Committee are rapidly getting their programme in shape, and it is expected that the discussions following the reading of most of the papers will be most interesting, it being thought that the programme is exceptionally good, and it has been the aim of this committee to bring out stronger than ever the educational feature of the convention.

All delegates are requested to be sure to have membership cards with them, as this will facilitate registration at headquarters.

The commissioner of the Central Passenger Association has arranged to have an agent stationed here at the registration headquarters at the State Fair Grounds, so that all tickets may be validated and taken care of, without going to any other place, and causing unnecessary inconvenience.

The Michigan State Building at the



JOSEPH T. SPEER, PITTSBURG,
Vice-President A.F.A.



DR. RICHARD MOLDENKES,
Secretary American Foundrymen's Association.

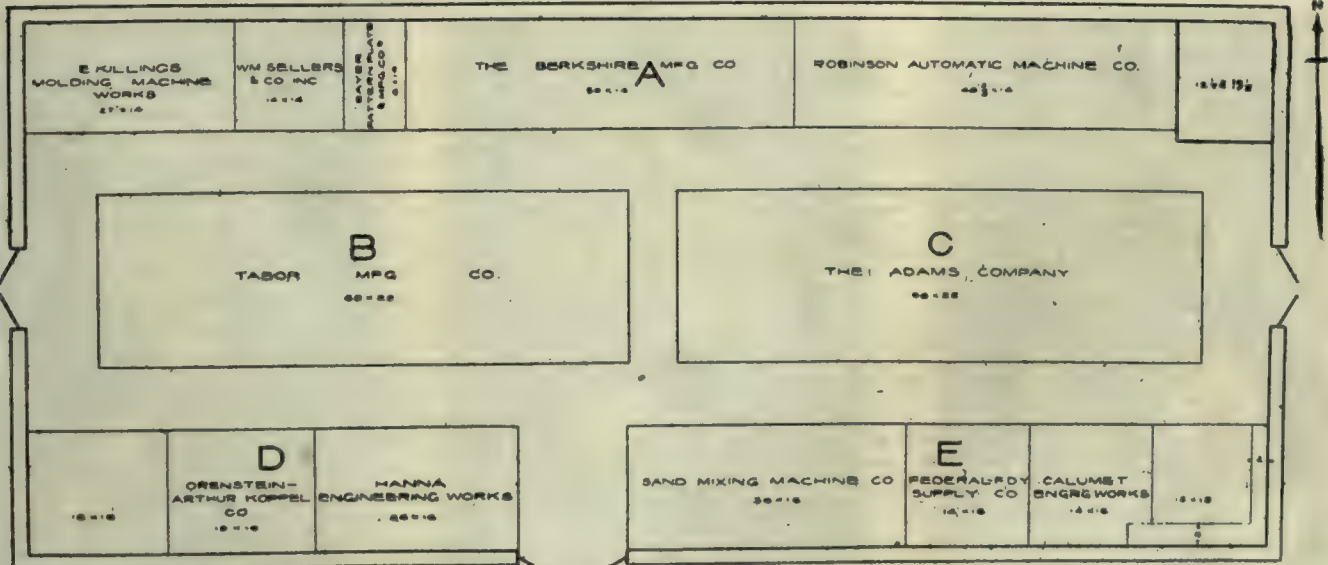
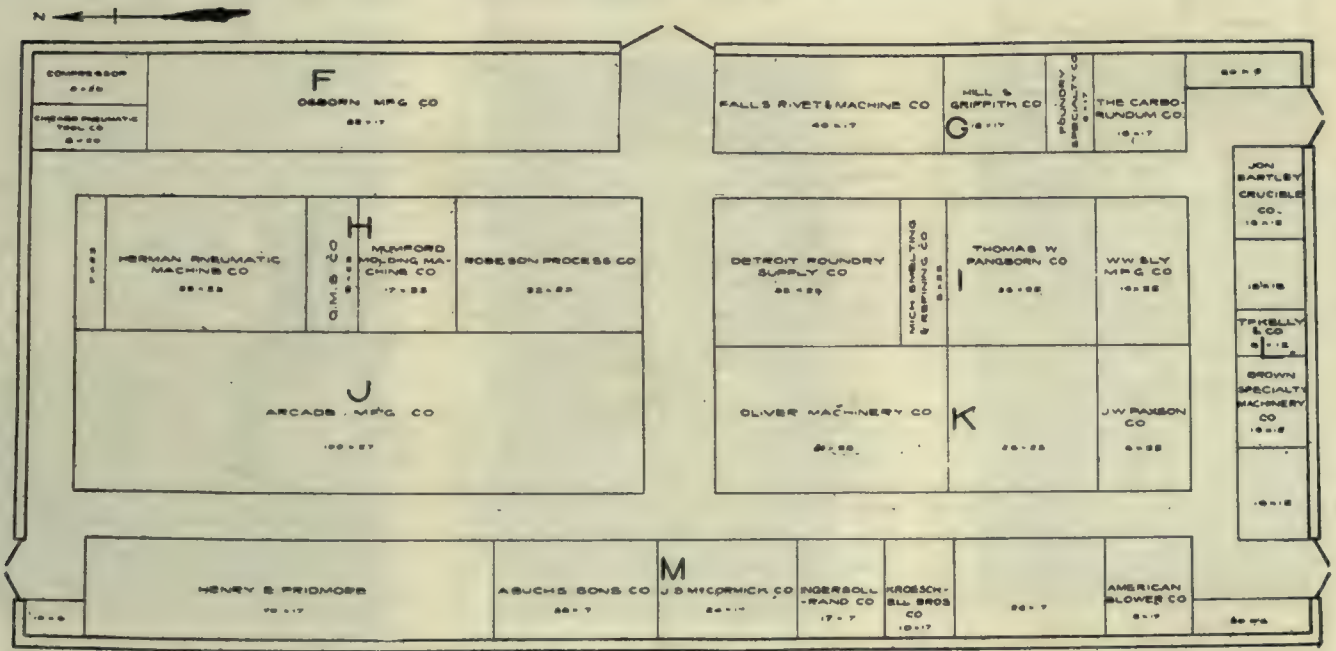
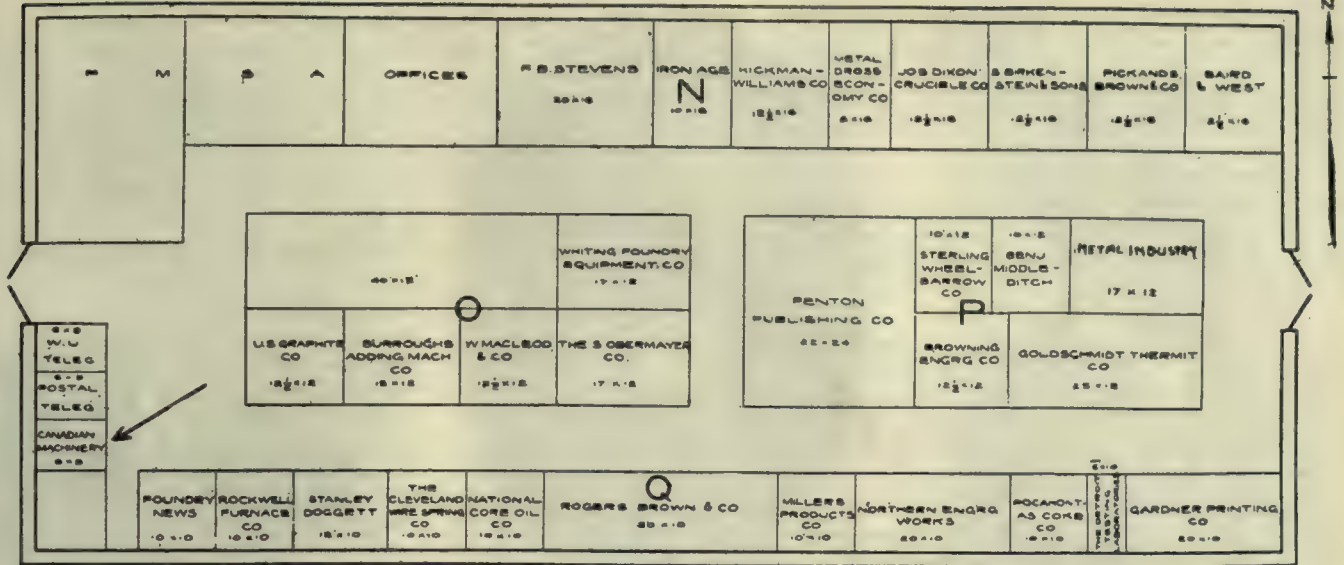

Plan View of the Exhibition Buildings, Detroit, and the Location of Exhibits.

Fair Grounds, where the sessions of the convention will be held is beautifully located, with large verandas on both floors, and will be an admirable place for the ladies to congregate and visit, if they do not care to attend the sessions as closely as the gentlemen.

The Detroit committee is working hard, we might say day and night, and it is hoped that they will not be dis-

Only about 17,000 ft. were in use at the Cincinnati convention, therefore the idea that the Detroit convention is to be the banner one of the organization, appears to have a firm foundation.

The Detroit local committee has provided a set of lantern slides dealing with convention matters, which will be loaned to any Foundrymen's organization in the country that sees fit to use

The exhibit will include a display of crucibles, stoppers, nozzles, sleeves, muffles, skimmers, stirrers, retorts, graphite bricks, special crucibles for patent furnaces, foundry facings and motor brushes. Representatives from the various branch offices will be in attendance.

Foundry and Manufacturers' Supply Association.

President, F. N. Perkins, Freeport, Ill.; Secretary, C. E. Hoyt, Lewis Institute, Chicago, Ill.; Treasurer, J. S. McCormick, J. S. McCormick Co., Pittsburg, Pa. The objects of the Association are for the commercial and technical education of iron and metal industries by co-operating with all foundry and manufacturing interests in making an annual exhibit of supplies and equipments in conjunction with the meeting of the American Foundrymen's Association.



The objects of the Association are for the commercial and technical education of iron and metal industries by co-operating with all foundry and manufacturing interests in making an annual exhibit of supplies and equipments in conjunction with the meeting of the American Foundrymen's Association.

American Brass Founders' Association.



President, Wm. R. Webster, Bridgeport, Conn.; Secretary and Treasurer; W. M. Corse, 1155 Sycamore Street, Buffalo, N.Y. The objects of the Association are for the educational welfare of the metal industry.

The objects of the Association are for the educational welfare of the metal industry.

TOOL STEEL FROM IRON ORE.

Tool steel at an initial 9 6-10 cents per pound has been produced direct from iron ore by J. W. Evans, Belleville, in a small electric furnace of 150 lbs. capacity. The steel was tested at Hamilton and McGill University, Montreal, with excellent results. At Belleville, where the furnace is installed, electric energy costs \$50 per horsepower per year. The cost per pound mentioned above is based upon this rate for power, and includes all charges, such as depreciation, briquetting, etc., etc.

Mr. Evans first produced tool steel direct from titaniferous iron ores in the electric furnace in 1906, and since then he has been following up the work perfecting the work to make it useful commercially.

The value of Mr. Evans' work has been recognized by the Canadian Mining Institute. During its recent annual meeting, the following resolution was passed: "Resolved, that the Institute desires to express its appreciation of the results achieved by J. W. Evans in his electric furnace, and regrets that illness prevents his attendance at this meeting."

Dixon Crucible Co. at A. F. A.

The Joseph Dixon Crucible Co., Jersey City, N.J., will exhibit at the coming convention of the American Foundrymen to be held this year in Detroit.

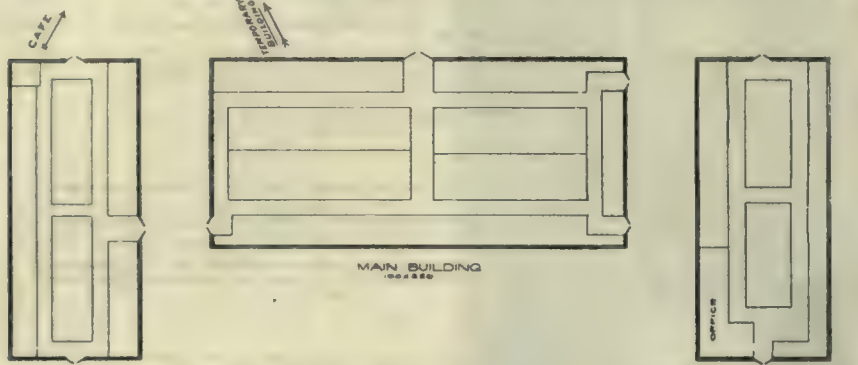

Horticultural Building. Plan View of Exhibition Buildings. Administration Building.

appointed in the attendance. The gates are wide open, and the key thrown away, so there is no danger of being locked in or out, but we are satisfied that no pleasanter spot in the United States can be found for a week's sojourn, and it will prove a happy vacation to those who attend the convention.

Temporary Building.

The Foundry and Manufacturers' Supply Association has decided to use a tent for temporary building at the convention and Secretary Hoyt has made an arrangement for a tent 30 feet in width and whatever length may be found necessary. The present tent is

them. Application for these slides, which are all properly labelled and with data to go therewith, should be made to Frank T. F. Stephenson, chairman of the local committee, at once, as several Foundrymen's Associations have already requested the use of these slides.

The Exhibits.

The illustrations show the layout of the buildings, and the names of the various exhibitors who will attend the convention. The Administration, Main and Horticultural buildings will house the exhibitors. The Michigan State Fair Grounds offer every facility for the convention. They are reached by

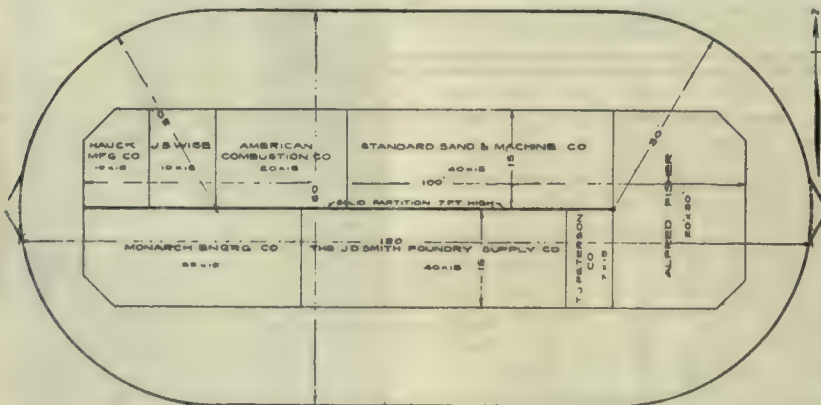

Plan View of Temporary Building, Showing Location of Exhibits.

120 feet in length, and the ends can be winged out to any desired extent. A heavy timber partition will be put down the centre of the tent, thus making the back wall for each exhibit, and the aisles will be laid on each side.

Over 30,000 ft. of floor space has already been asked for this convention.

the Woodward Ave. cars, which run direct to the fair grounds.



WILLIAM R. WEBSTER, BRIDGEPORT,
President A.B.F.A.



N. K. B. PATCH, TORONTO.
Chairman Papers Comm., A.B.F.A.



C. E. HOYT, CHICAGO.
Secretary M. & M. S. Assoc.



R. R. MITCHELL, MONTREAL,
Vice-President, A.B.F.A.

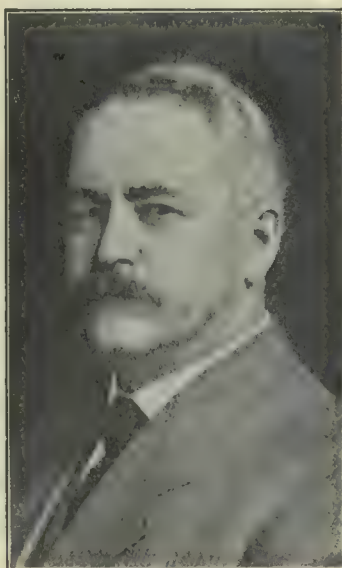

F. M. PERKINS, FREEPORT,
President F. & M. S. Assoc.



EUGENE W. SMITH,
President Associated Foundry Foremen.



W. M. CORSE, BUFFALO,
Secretary A.B.F.A.



R. S. BUCH, PITTSBURG,
Vice-President F. & M. S. Assoc.

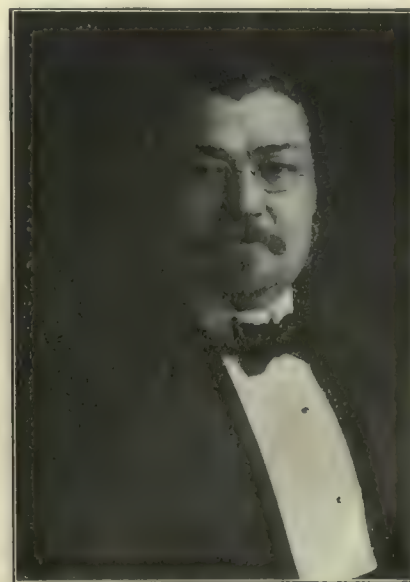

DR. FRANK T. F. STEPHENSON,
Chairman Local Comm. A.F.A.



DE LA MOTTE HENRY,
Chairman Ladies' Committee.

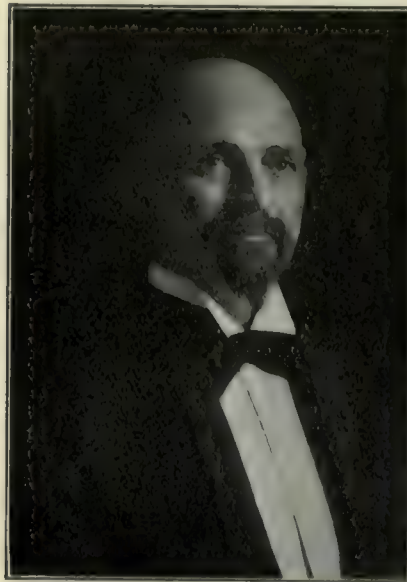

JAMES S. KEIGHTLY,
Chairman Reception Committee.

W. W. SLY MFG. AT DETROIT.

Among the exhibitors at the Detroit Convention A.F.A. and allied associations, will be the W. W. Sly Mfg. Co., Cleveland. W. W. and W. C. Sly are popularly known as the "cleaning mill" men, their tumbling mills being a special-



W. W. SLY.
President W. W. Sly Mfg. Co., Cleveland.
New Radial Drill, Mueller Mch. Tool Co., Cincinnati.



FREDERIC B. STEVENS,
Treas. Local Comm. Allied Foundrymen's Association.



Hotel Pontchartrain, Headquarters A.F.A. and A.B.F.A.



W. C. SLY,
Secy. and Treas. W. W. Sly Mfg. Co.



EDWARD J. WOODISON, DETROIT,
Chairman Entertainment Comm.



Hotel Cadillac, Headquarters F. and M.S. Assoc.

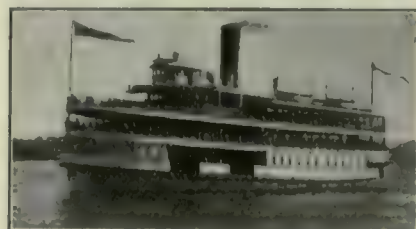

Steamer "Britannia", Excursion Boat for Convention.

ty with them. Mr. W. W. Sly is a dog fancier and the Sly dogs (thoroughbreds) are well known among his friends.

Opportunity is represented as having long hair in front and being bald behind. He may be grasped when he meets you, but not after he passes.

FOUNDRYMEN'S CONVENTION PROGRAMME.

The following is the program of the convention of the American Foundrymen's Association and allied organizations:

Opening Session, Tuesday, June 7, 10 a.m.

Addresses of welcome.
Response.
Presidential address, Arthur T. Waterfall, for the A. F. A.
Presidential address, Wm. R. Webster, for the A. B. F. A.
Secretary and treasurer's report, W. M. Corse, for the A. B. F. A.
Secretary and treasurer's report, Dr. Richard Moldenke, for the A. F. A.
"Acetylene-Oxygen Repairs in the Foundry," with an exhibition of the art as practically applied, by Steelman Stephenson, of Detroit.

Second Session, 2 p. m.

American Brass Founders' Association.
"Analyses of Lead in Brass Alloys," by C. P. Carr, New York City.
"Fluxes as Applied to the Brass Foundry," by Wm. R. Sperry, Bridgeport, Conn.
"Use of Magnesium in Deoxidizing Aluminum Alloys," by H. M. Lane, Cleveland.

3 p.m.

American Brass Founders' Association.
"Foundry Efficiency," by Benjamin D. Fuller, Cleveland.
"The Personal Equation in Accidents," by Thomas D. West, Cleveland.
"The Permanent Mold," by Edgar A. Custer, Philadelphia, illustrated by lantern slides.

Evening.

Smoker, given by the Detroit Foundrymen's Association to members of the allied associations at the Light Guard Armory.
Theatre party for the ladies at the Temple theatre.
Headquarters for visiting ladies at Parlor H. of the Pontchartrain hotel, where members of the ladies' committee of Detroit will be present at all times to give the necessary assistance and information to the visiting ladies.

Third Session, Wednesday, June 8, 10 a.m.

American Brass Founders' Association.
Address on "Brass Foundry Practice," by Jesse L. Jones, Pittsburg, Pa.
"Electric Power Required to Melt Brass, Bronze, Etc.," by Prof. J. W. Richards, South Bethlehem, Pa.
"Electric Furnaces for Melting Non-Ferrous Alloys," by A. L. Marsh, Detroit, Mich.

11 a.m.

American Foundrymen's Association.
Report of Committee on Chemical Standards for Iron Castings, by Prof. J. J. Porter, Cincinnati.
"Physics of Cast Iron," by H. M. Lane, Cleveland.

Wednesday Afternoon, 2 p.m.

Pleasure boat ride on Detroit river, steamer Britannia, stopping at Smet-Solvay coke ovens, and Detroit Iron & Steel Co.'s blast furnaces, continuing down the river to see the government work on Livingstone channel.

Fourth Session, Thursday, June 9, 10 a.m.

American Brass Founders' Association.
"The Value of the Association to Its Members," by Frank T. F. Stephenson, Detroit.
"Co-Operative Course of Metallurgy," by Prof. J. J. Porter, Cincinnati.
"Cost and Cost Systems Applied," by C. R. Stevenson, New York City.

11 a.m.

American Foundrymen's Association.
"The Shockless Jarring Machine," by Wilfred Lewis, Philadelphia.
"The Universal Principle of Efficiency and Rational Organization Applied to Foundry Practice," by S. D. Emerson and W. J. Powers, New York City.

Thursday, 2 p. m.

Automobile sight seeing trip around points of interest for the ladies, starting from Hotel Pontchartrain.

Fifth Session, Thursday, 2 p. m. American Brass Founders' Association.

Unfinished business.
Election of officers.
New business.
3 p. m.
American Foundrymen's Association.
Report of committees.
Unfinished business.
Election of officers.
New business.
"Overhead Tramrail Systems for the Foundry," by A. W. Moyer, Philadelphia, illustrated by lantern slides.
"The Electric Furnace," by H. M. Lane, Cleveland, illustrated by lantern slides.

Sixth Session, Friday, June 10, 10 a. m.

American Foundrymen's Association.
"Foundry Transportation Methods," by David Gahr, Cleveland.
Report Committee on Industrial Education, by P. Kreuzpointer, Altoona, Pa.
"Specifications for Foundry Coke," by Dr. Richard Moldenke, Watchung, N.J.
Discussion of continuous conveying methods and foundry mixer.
Adjournment.

HE GOT THE JOB.

"Norman MacLean, Foreman," printed in large letters on the door of the little office overlooking the machinery department, looked as if he had gotten along well in the world. He wasn't in the office when I called, but glancing over the shop I saw him showing two



How He Got the Job.

young fellows how to attack a new job, and decided to wait until he was free.

I just got seated when an old grey fellow, covered with grime, came in from the foundry with a message. I said good-day to him and we talked of the weather, etc. Then the talk drifted to Norman MacLean, Foreman. The old man was quite familiar with things around the place and remembered when "Norm" started to work.

I hadn't heard how Norm got his first job, and was interested in hearing the old man tell the story. Norm couldn't and wouldn't plow and left for town to find a job. That much I knew. There

comes a time to most of us when we must approach the "boss" for a job, and it is usually a very timid applicant that meekly asks the high and mighty man for a job. There is a certain "art" about getting a job, and Norm evidently meant to secure one at the first place he called.

On reaching town he at once made his way to the Harte Engineering Works, where he approached the "boss." The boss was not in a particularly quiet frame of mind. His "What on earth are you good for?" somewhat surprised Norm, and his answer somewhat surprised the boss. "I want to be foreman here, but since that position is filled, I'll be content to be one of his assistants."

The boss looked him over and hesitated. There was some more talk ending with the boss telling him, "If I call you back before you reach the pavement, I'll give you a job."

Norm was resourceful. He walked out of the little office and started for the door of the works. Then he hesitated. He had an idea. On the floor, lying close to the door was a new die stock that had just been delivered.

Norm looked back at the little office saw the foreman was looking, picked up the die stock on his shoulder and ran for the works door. Of course, the foreman was after him in a second, shouting to bring the die stock back.

Norm walked back, took off his coat, looked at the boss, and asked what he would do. The boss looked him over for the second time and said "Youngster, I'll hire you," and that is how Norman MacLean began his career in the shops in which he is now foreman.

Factory expenses can vary tremendously. Repairs is an especially elusive item. By keeping repair accounts separately, when old equipment, poor piping, wiring and machinery are proving expensive, the accounts will show at once that it is wise to replace old equipment with new.

Pure cement, one manager has found, mixed neat with water shows a slightly alkaline chemical reaction, and has proved a good preservative for steel and iron when applied to such surfaces with a paint brush. It is necessary that the coating be continuous if this method of rust-proofing is to prove satisfactory.

One manager includes the item of packing expense in shop cost instead of grouping this item with the selling expenses. While most concerns follow this latter procedure, this manufacturer believes that since his warehouse is his stockroom and nothing is packed except orders and no crated stock appears on the inventory, the packing expense can logically be a part of shop cost.

PATTERN MAKING KINKS.

By F. G. C.

There are many things in pattern making which appear trifling, but which really are of the greatest importance and chief of these is the fillet.

We all know how much the appearance of a pattern or casting is improved when nicely rounded instead of sharp at the edges, and with all the corners filleted. We also learn by experience that the moulder has much less trouble drawing such a pattern from the sand. But the greatest reason for filletting all

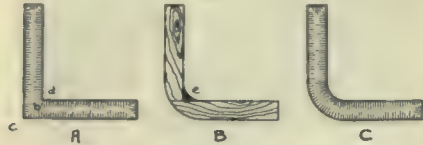

Fig. 1.—Strength of Castings.

corners wherever possible is for maximum strength with minimum weight whether iron, steel, brass, bronze or any other cast metal be used.

This difference of strength is shown clearly in Fig. 1. A represents a casting having sharp corners. When the metal crystallizes after being cast the crystals form into a kind of grain running at right angles to the face of the casting; and, wherever a sharp corner occurs these grains become broken, leaving a bad spot as shown at b, thereby making the casting weak across the line c-d. But if a fillet is put in the pattern as shown in the section B at the corner e, then we will get a casting as shown at C, without having any irregular crystallization as in section A.

A good illustration of the faulty results that may happen where sharp corners are allowed to exist is shown in Fig. 2. The cylinder shown at A was

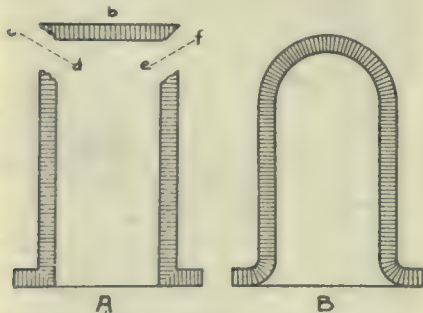

Fig. 2.—Results of Sharp Corners.

cast with sharp corners and a square bottom. When the pressure is applied to the interior of the cylinder the head b will be forced out, as shown in the illustration, the break occurring along the line c-d and e-f. If this cylinder had been cast as shown in Fig. 2-B with a

round end, it would be proportionately strong all over, and, in fact, the end would be even stronger than the sides which withstood the pressure in the cylinder a.

The best fillet material is wood, whether put on from a strip or worked out of the wooden pattern. For irregular curves, the leather fillet is best, fastened to the pattern with shellac rather than glue, as the glue often gives away when the pattern is put in the wet sand. Then for small, very irregular patterns, we can use beeswax, in its pure state or in composition with tallow, rosin, linseed oil and red ochre or whiting, making a dark or light fillet or pattern filler, as the case may be. The formula for one of the compositions is: 1 quart linseed oil, 7 pounds beeswax, 7 pounds of whiting, and 1 pound of rosin, the whole heated in a pot till thoroughly mixed and applied when warm.

Wood, leather and metal fillets are on sale in every city, so require no comment, but the wax fillets are usually made by the pattern maker. A very convenient way to make them is to take a small piece of brass tube about $1\frac{1}{4}$ " inside diameter and about 8" long, securing a cover on one end with a round hole or an opening, the shape of a leather fillet, if so desired. Inside have a plunger secured on the end of a threaded rod, about $\frac{3}{8}$ " diameter, which passes through the cover on the other end, which must be removable (a screwed on cap is best to permit the warm wax solution to be poured in and forced through the small hole at the bottom. The $\frac{3}{8}$ " threaded rod which screws through the cap is usually squared on the projecting end, suitable for turning with an ordinary hand brace.

The wax fillets when cold are pressed into the corners of the pattern by means of a warm iron, which is rounded to make the proper size fillet from material used.

CANADIAN RAILWAY CLUB.

A. A. Maver, Master Mechanic of the Grand Trunk, was last night elected president of the Canadian Railway Club, Montreal, to succeed H. H. Vaughan.

The election of officers went by acclamation, the report of the nominating committee being unanimously accepted, and resulting as follows:

President—A. A. Maver, master mechanic, Grand Trunk.

Vice-president—A. A. Goodchild, auditor of stores and mechanical accounts, C.P.R.

Second Vice-president—James Coleman, superintendent of the car department, Grand Trunk,

Secretary—James Powell, box 7, St. Lambert near Montreal.

Treasurer—S. S. Underwood, chief draftsman of the Grand Trunk.

Executive committee—Messrs. A. L. Grayburn, 3rd vice-pres., C.N.R., Toronto; R. W. Burnett, master car builder, C.P.R., Montreal; H. C. Butler, C. Kyle, general master mechanic eastern lines, C.P.R., Montreal; William McNab and F. Ditchfield, Supt. Dominion Car & Foundry Co., Montreal.

Auditors—Messrs. H. A. White, J. S. Johnstone and G. I. Evans.

Some discussion arose as to the advisability of putting this surplus, which amounts to \$2,905 this year, to some practical use instead of leaving it to draw interest in the banks. It was proposed by A. A. Goodchild that this fund should be utilized for the establishment of a reference railway library in connection with the club.

This idea met with immediate approval, and on motion of Mr. Goodchild, it was decided to authorize the new president to appoint a committee to look into the matter and report at the next general meeting.

As soon as this business was concluded, S. King, of the Canada Car Co., called H. H. Vaughan, the retiring president, to the front and presented him with an engraved gold past-president's jewel, which was duly acknowledged by Mr. Vaughan amidst applause.

A brief address by Grant Hall, president of the Western Canadian Railway Association, of Winnipeg, closed the formal proceedings. These were followed by a smoking concert, at which piano solos were given by N. Eichorn; Scotch songs by Mr. Ferguson; instrumental selections by Messrs. Wilson and Smith; songs by Messrs. Rice, Clark and Armstrong, and some interesting card tricks by "Doc" Ware.

The Detroit Foundry Supply Co., Detroit and Windsor, have closed several agencies for foundry equipment for Canada. One of these is for the Anthony Co., New York, manufacturers of Nebulyte Crucible Oil Furnaces. These will be manufactured in Windsor. They use a fine spray as atomizer, combustion is excellent. The life of the crucible is prolonged 50 per cent. and it will melt brass with $\frac{3}{4}$ gallon to 100 lbs. It is a noiseless furnace. Another agency is for adjustable eccentric clamp. A third is for an aluminum snap flask.

J. Walter Keith, formerly treasurer of the Frost & Wood Co., Smith's Falls, Ont., has accepted a position in Calgary, Alberta.

INDUSTRIAL and CONSTRUCTION NEWS

Establishment or Enlargement of Factories, Mills, Power Plants, Etc.; Construction of Railways, Bridges, Etc.; Municipal Undertakings; Mining News.

Foundry and Machine Shop News.

The John Deere Plow Co. are erecting a 100,000 block at Saskatoon.

The C. P. R. will build a new roundhouse and machine shop at London.

Bennett & Phelan, brass and bronze founders, Montreal, have been registered.

M. H. Braden was awarded the contract for a \$25,000 garage for the Northern Automobile Co., Fort William.

The Vancouver Exhibition Association have decided to erect a new Machinery Hall to cost \$20,000.

M. H. Braden, of Fort William, has been awarded the contract for the new C. P. R. shops at that place.

The machine shop of John Ballantyne & Co., Preston, together with the pattern rooms, was burned on May 26.

The Morrisburg Tack Mfg. Co., Morrisburg, Ont., after the erection of the tack factory will erect one for the manufacture of nails.

Heinbuch & Kischell, machinists, Stratford, Ont., have dissolved, George Heinbuch will continue alone under his own name.

The Denis Wire & Iron Works Co. have been authorized by the Dominion Government to increase their capital from \$51,000 to \$100,000.

The Canada Cycle & Motor Co., Toronto, is in its busiest season and reports a decisive demand over last year for bicycles and automobiles.

The Eastern Canada Steel & Iron Works will erect a plant for the manufacture of structural steel for buildings, bridges, etc., at Quebec.

C. H. Macmillan, in charge of the Bethlehem Steel Works is rejoining the staff of the Dominion Iron and Steel Co., as assistant general manager.

W. Minto, Jr., has taken over the bicycle and machine shop business conducted for some years by George J. Barrett at Fredericton.

The Silliker Car Works, Halifax, have at present six hundred hands on their pay roll and the company are running a double shift—day and night.

The Waterloo Mfg. Co., Waterloo, manufacturers of steam engines and threshers, is going into the manufacture of gasoline engines extensively, for western trade.

W. G. Chater, manager of the Hespeler Machinery Co., Hespeler, Ont., has returned from an extended trip through the west in the interests of the company.

The Corbet Foundry & Machine Co., Owen Sound, is enlarging. To carry on the increased work the company has been incorporated with a capital of \$40,000.

The Atikokan Iron Co. will build 100 more ovens in connection with the blast furnace plant at Port Arthur, and will increase the capacity from 100 to 150 tons of pig iron per day.

The Maloney Mono-rail System Co. have been organized with a capital of \$200,000, and it is stated that shops will be erected at Montreal, Levis, Toronto, Ottawa and Medicine Hat.

The Canadian Locomotive Works, Kingston, have received an order for 25 locomotives for the Grand Trunk Pacific, and 10 for the Grand Trunk. They are all of the mogul pattern.

The D. J. Barker Co., of Picton, Ont., will build a large addition to their stove foundry. A new furnace for smelting iron, has been installed with fifty per cent. more capacity than the old one.

The new plant of the Mounted Steel Works, is to be started immediately at Longue Pointe, Que., and it is estimated that nearly two million dollars will be spent within two years.

One of the buildings of Hills & Sons' foundry, Halifax, on the Campbell road was gutted by fire this morning and the firm's loss is estimated at \$7,000 or \$8,000 beyond the amount of insurance.

The London Concrete Machinery Co., London, have acquired a large section of land

on Kitchener avenue, East London, where they will erect new buildings, enlarge their plant and employ forty more men.

The Kootenay Engineering Works, Nelson, will remove their plant to Vancouver in June. Manager B. C. Travis has decided to engage in marine repair work, which he followed for years in Portland before coming to Canada.

J. & J. Taylor, safe manufacturers, Toronto, have been steadily increasing their working force during the spring and now employ about 300 men. They have extensive orders on hand and are completing the extension to their plant.

At a conference with the Council of the Board of Trade, Quebec, May 18, the assurance was given by Hon. S. N. Parent, Chairman of the National Transcontinental Railway, that the workshops of the railway would be located at Quebec.

John McDonald, moulder of the foundry department of the Dominion Iron & Steel Co., Sydney, has resigned his position with that concern to take the post of foreman in charge of the foundry department of the Sydney Foundry and Machine Works.

Canadian American Gas & Gasoline Engine Co., Dunnsville, capital \$150,000, to manufacture business of iron, steel and wood construction; directors, F. R. Lalor, W. J. Aikens, G. R. Smith, R. A. Harrison, J. Bradford, G. McCrea, H. M. Burgar, B. S. Depoty.

The Perritt Iron & Roofing Co., incorporated under the laws of New Jersey, have been granted a license by the Ontario Government to manufacture and deal in iron, steel, machinery, Portland cement and hardware. J. E. Swinburne, Fort William, is appointed attorney for the company.

The Canadian Locomotive Works at Kingston were awarded contracts by the Temiskaming & Northern Ontario Railway that will reach \$160,000. These include the building of four powerful locomotives of the Pacific type for \$90,000, twelve cinder cars for \$15,000 and fifty box cars with steel frames for \$55,000.

The London Bolt & Hinge Works was sold by auction by J. W. Jones Monday afternoon, for \$55,000, to George C. Gibbons, acting for T. S. Hobbs, one of the present partners. The works now employ about 100 hands. The factory, which has been closed 60 days for stock-taking, will be opened immediately, and will be enlarged to double its present size.

At the annual meeting of the Provincial Steel Co., Cobourg, F. W. Coolbough, who has acted as manager since the industry commenced operations, a year ago, resigned. He is succeeded by Mr. Reeding, a former Government inspector of rails. Mr. Coolbough has disposed of his interests to Robert Heath, of England, who now holds the controlling interest in the industry.

The Gurney Foundry Co., Toronto, have opened their new warehouse at Toronto. It will now be possible to systemize the working of the factory by running the cast iron stoves through their process of manufacture to the left, on to the new warehouse, while the steel products will work their way in the opposite direction. The company's plant at Toronto Junction has also been enlarged recently.

The Nova Scotia Steel & Coal Co. have placed a large order for steam turbine plant with an English firm. The plant is for use at their steel works at New Glasgow and consists of two 750 horse-power Rateau patent steam turbines direct, coupled to electric generators, also one Rateau patent heat accumulator, two sets condensing plants with electrically driven pumps, switchboard, etc.

A factory has been started in Port Arthur under the name of the Port Arthur Chain Works by practical men from Birmingham, England, who, realizing the demand for chain in this country and the northwest, selected Port Arthur as the most advantageous point at which to manufacture.

A Constant-Speed Drive

A fundamental underlying principle of a constant-speed drive and the mechanically obtained speed changes incident thereto is convenience.

Any machine so designed as to entail the absolute stoppage of the driving pulley, as well as the machine in order to change speeds by the shifting of a tumbler gear or engagement of a positive clutch does not in any way meet the requirements of the case.

Friction back gears are, comparatively, an advantage, but the quick change so obtained is too great. Quick speed changes should have but a slight increment from one to another, in order that the surface speed of the work may be readily and properly accommodated to the capacity of the cutting tool.

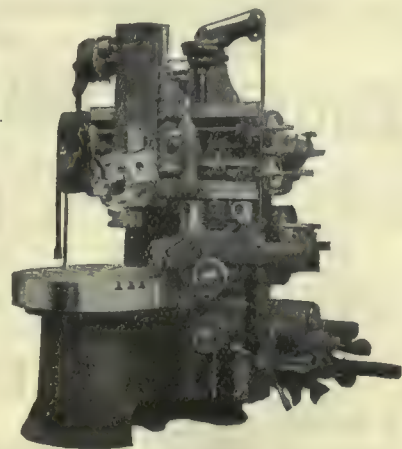

A perfect constant-speed drive is one of the many features incorporated in the VERTICAL TURRET LATHE which tend to make it such a remarkable machine for rapid production of absolutely perfect work.

This feature is only one of the many incorporated in the VERTICAL TURRET LATHE which is fully illustrated in catalog C-15, which is free for the asking.

The Bullard Machine Tool Co.
Bridgeport, Conn., U.S.A.

BETTER RESULTS AT LOWER COST

can be secured for any class of castings by arranging your mixtures by analysis. Years of practical experience in foundry work are at your service when you consult with

The Toronto Testing Laboratory, Limited

18 SATURDAY NIGHT BUILDING, TORONTO
EXPERT FOUNDRYMEN, METALLURGISTS, CHEMISTS
TESTS OF METALS, FUELS, CORES, OILS, Etc., AT REASONABLE PRICES.

BABBITT METALS

FOR ALL PURPOSES

LUMEN BEARING COMPANY
BUFFALO TORONTO

INFORMATION

about every conceivable subject finds its way into the newspapers. The function of THE CANADIAN PRESS CLIPPING BUREAU is to collect ALL the items of information appearing in Canadian newspapers about any subject YOU are interested in. Our service is thorough. We don't miss an item. If you want ALL THE CURRENT INFORMATION about a pet subject, we can supply it at the lowest cost. By using our service you can KEEP POSTED on any subject.

WRITE FOR OUR FREE BOOKLET

THE CANADIAN PRESS CLIPPING BUREAU

232 McGill Street, Montreal

10 Front Street E., Toronto

HERE IS A SPLENDID

Sensitive Column Drill

For drilling holes up to 5/16 of an inch it gives remarkable satisfaction. The spindle has two speeds and is driven by a 1" flat belt. It is relieved of all belt strain, is counter-balanced and provided with means for taking up wear. As the column is graduated by a vertical line its full length, the centre of the table may be set in line with the spindle at any point of vertical adjustment. A cup centre is furnished with each machine as a substitute for the table in centring small work. *Write for Circular and Price.*

**D. McKENZIE**

9 Nottingham Street

GUELPH, ONT.

**BEST
LEATHER
BELT
MADE**



TORONTO

ST. JOHN, N.B.

MONTREAL

WINNIPEG

VANCOUVER

They intend bringing out a number of practical chain men from Birmingham during the year.

The New Way Motor Co. is the latest addition to Welland's Industries. It is capitalized at \$50,000, and will manufacture gasoline engines. The directors are: W. H. Newborough, president; E. W. Goodnow, L. M. Gleason, H. E. Thomas, C. D. Woodbury, all of Lansing, Mich. The factory will be the Canadian branch of the Lansing factory.

Jas. Pender, of the J. Pender Co., St. John, manufacturers of wire nails, was in Montreal and Ottawa, last month, in connection with the patenting of an invention of his own developing which has been put through most of the preliminaries necessary for its protection. It is an improvement upon the present process of manufacturing wire nails which Mr. Pender believes will be of great value to the art.

The Positive Clutch & Pulley Works have equipped a shop at 11-13 Jarvis St., Toronto, where they will manufacture the combined jaw and friction clutches, "Ideal" wood rim steel centre pulleys and improved power transmission appliances. These appliances are patented in Canada and foreign countries. Thos. Hook is president of the company; Chas. S. Hook is vice-president and manager, and Norman F. D. Beard is secretary-treasurer.

The Wind Engine & Pump Co., Toronto, having recently increased its capital from \$250,000 to \$750,000, is planning the establishment of a plant for the manufacture of gasoline engines. Negotiations are in progress with the town of Dundas, Ont., looking to the location of the industry there. An addition is being made to the company's warehouse in Winnipeg and a new warehouse is being opened in Calgary, where a distributing branch was established in January. A distributing warehouse will also be built in Regina.

The Canadian Pacific machine shops at Fort William are to be doubled in capacity. An addition of 128 feet by 70 wide is to be added to the present building. This will bring the Fort William shops next to those at Montreal, Winnipeg and Vancouver in point of size. Tenders for this construction are now being called for. When these enlargements are completed Fort William will be the headquarters of the mechanical department between Chalk River and Winnipeg. Machinery to the value of \$70,000 has been already ordered and will be installed as soon as the building is completed.

The Polson Iron Works, Toronto, has more work on hand than at any time during the last three years. It has since the beginning of the year, increased its force by over 200 men and now employs about 500. Among the contracts now on hand are a dredge for the harbor commissioners of Montreal, carrying a five cubic yard bucket; a suction dredge, 22-inch pipe, for the Great Lakes Dredging Co., of Port Arthur; a steel passenger steamer for the Canadian Pacific Railway, to be forwarded to British Columbia in knock-down condition and put together on the Kootenay lakes; a large new ferry for the Toronto Ferry Co., and several smaller orders. They have also several orders for boilers on hand.

The plant of Hillis & Sons, Halifax, suffered from a fire on May 3. It destroyed the pattern shop and storage room, together with part of the stove patterns and all of the wood patterns, the accumulation of thirty-five years. The machinery and power plant were saved, and the molding and machine shops are running as usual. A large stock of stoves was on hand in another building, which will be sufficient to take care of the spring business. The lost patterns will be replaced in time to continue without serious inconvenience to customers. The burnt building is being rebuilt as rapidly as possible, and improvements are being made which will greatly facilitate the progress to the work.

General Manufacturing News.

The Eli Sand Co., Winnipeg, will erect a factory to cost \$50,000.

The B. F. Nelson Mfg. Co., Minneapolis, will erect a factory at Regina.

The Maple Leaf Milling Co., Winnipeg, have let contracts for the building of 17

elevators in Saskatchewan to the W. A. Harper Construction Co., at \$102,000.

The Dominion Oil Cloth Co. will erect a factory at Montreal, to cost \$80,000.

The Western Canada Flour Mills Co. will build a grain elevator at St. Boniface to cost \$275,000.

The Dougall Varnish Co., Montreal, have specifications out for a \$40,000 factory at Point St. Charles.

David Elliott, of the Elliott Mfg. Co., Toronto, will establish a paper box industry in Ashbridge's marsh.

A. A. Barthelmes & Co., Toronto, have a permit to erect a five-storey and basement factory, to cost \$46,000.

The Trussed Concrete Steel Co. will erect a \$75,000 flour mill at Saskatoon for the Saskatchewan Milling Co.

The James Power Co., Toronto, are seeking to locate a factory for the manufacture of motor car requisites at Ottawa. Estimated expenditure on building, \$10,000

The contract for the building for the Supreme Heating Co., Welland, was secured by Contractor Patton. It is anticipated that more additions will be necessary in the near future.

The Dominion Iron & Steel Co., Sydney, have just placed a big contract with the Morgan Construction Co., of Worcester, Mass., for the construction of a new rod and bar mill.

The box business of Wm. Rutherford & Sons Co., and the more recently formed Montreal Wire Bound Box Co., have been merged under the name of the Dominion Box and Package Co.

Negotiations are on with the Kingston City Council, to sell a part of the city smelter site to the Canadian Lead Mining & Smelter Co., which desires the land for the establishment of their smelting business.

At Wakefield, Quebec, the MacLaren woollen mill, the MacLaren grist mill, and four houses owned by the company, were burned, involving a destruction of property to the value of \$50,000, nearly all covered by insurance.

The Sykes woollen mills Georgetown, were destroyed by fire May 17. Manufactured goods valued at \$12,000, which were stored ready to ship, and a quantity of valuable machinery used in the plant were burned. The total loss is estimated at about \$30,000, largely covered by insurance.

The Bryan Mfg. Co., Collingwood, have prepared plans for extensions which they propose to make to their premises. A new dry kiln will be erected at once. The contract for the equipment of this building has been given to the Sheldon Mfg. Co., Galt. In the fall a second factory is to be constructed as well as a new office building.

The H. S. Peters Co., Dover, N.J., manufacturers of Brotherhood overalls and kindred garments, will locate in Welland. The site is on Alexander street and a three storey brick factory building will be constructed. About twenty-five hands, mostly girls, will be employed at the start, to be increased to two hundred. The town will be asked to fix the assessment at \$1,000 for ten years.

Municipal Enterprises.

A by-law was voted on at Regina to issue \$280,000 sewer debentures.

The Dauphin, Man., waterworks and sewerage by-law to raise \$175,000 was passed.

A by-law to expend \$55,000 on the Ingersoll, Ont., water works was carried by the ratepayers.

Windsor ratepayers approved of the expenditure of \$20,000 to induce industries to locate there.

Chipman & Powers, Toronto, have been asked to outline plans for waterworks at High River, Alta.

Fernie, B.C., has decided to raise \$1,900 for water extensions, \$2,700 for surface drainage and \$41,000 for sewers.

A by-law to raise \$27,000 will be submitted shortly for the installation of a waterworks system at Chippewa, Ont.

Amherst, N.S., ratepayers have authorized the Town Council to borrow \$30,000 for the purpose of extending the sewerage system.

The Private Bills Committee of the Quebec Legislature has authorized Montreal to

borrow \$5,000,000 for the establishment of a filtration plant.

The Campbellton, N.B., Council let the contract for bar lead, lead pipe, wrought iron pipe and fittings, and brass goods to the Jas. Robertson Co., St. John.

The Strathcona City Council will engage Engineer A. C. Potter, of New York, to look over and make recommendations for the best sewerage system for that city.

A new six-million-gallon turbine pump, costing \$30,000, will be among the items in the \$375,000 bill for water extensions at Montreal.

J. D. Whitmore, formerly city engineer of Moose Jaw, with T. A. Murray, is planning a new waterworks and sewerage system for Swift Current, Sask.

The Lethbridge Council have adopted the following estimate of expenditure on anticipated works: Sewer main extensions, \$40,000; water main extension, \$67,000; sewer outlet, \$42,000.

The Winnipeg Board of Control will call for tenders for the following sewers and water mains in Elmwood: Sewers—Martin Avenue, \$4,251; Tweed Avenue, \$4,983; Basswood place, \$2,411; Sherbourne Street and Andrews Street.

Sealed tenders addressed to C. O. Davidson, City Clerk, Prince Albert, Sask., will be received until June 11th, 1910, for two Return Tubular Boilers, 72 inch x 18 feet, to maintain a working pressure of 150 pounds per square inch.

At a meeting of the St. Johns City Council the city engineer was authorized to expend some \$38,000 in the renewal of water mains about the city. The city is calling for tenders for permanent street pavement, to cost about \$90,000.

James Milne, Vancouver, consulting engineer for Prince Rupert, B.C., sends the following list of successful tenders for the \$60,000 Prince Rupert power plant: Boilers, induced draft apparatus and steam pipes, Goldie & McCulloch, Galt; switchboard and exciter, Canadian Westinghouse Co.; surface condenser and pump, John Ingles Co., Toronto; alternator and arc light apparatus, Canadian General Electric Co., and two cross compound engines to Robb Engineering Co. Goldie & McCulloch's tenders were submitted by Mather & Yuill, Vancouver.

Sawmills.

Another sawmill will be built at Naksup, B.C.

W. Craig will build a sawmill at Stoneham, Que.

Desrosier's planing mill, Ottawa, was burned on May 26.

Jno. McCrea has opened a sash and door factory at Port Arthur.

U. Boucher & Co. will erect a sash and door factory at Farnham, Que.

The Fort George Lumber & Navigation Co., Vancouver, B.C., will shortly enlarge their plant.

The sash and door factory of S. Hill & Son, Saskatoon, was totally destroyed by fire on May 26.

The planing mill owned by John Pierson, Stevensville, Ont., was destroyed by fire. Estimated loss \$10,000.

The sash and door factory of H. Fauteau, Fauteau avenue, Montreal, was damaged to the extent of about \$9,000.

The saw mill and planing mill, owned by J. S. Deschamps, Rossland, B.C., were destroyed by fire. Estimated loss, \$35,000.

The Taplin Timber Co., Toronto, have commenced the erection of a large sawmill on the shore of Lake Sasaginaga, near Cobalt.

Fire which broke out on May 4th in Robert Balcom's lumber and planing mills at Vienna, Ont., destroyed the entire plant. The loss is partly covered by insurance.

The National Timber & Pulp Co., Toronto, intend to erect a large pulp mill at the junction of the Ste. Anne and St. Lawrence rivers, in Quebec, as well as a new sawmill.

T. Harrison, of Kenora, states that his mill will give employment to a large force of men this year and will be in full operation all summer as a good supply of logs is on hand.

Atkins & Hardy, Owen Sound, have let contracts for their new factory for the manu-

ONE MAN
can cut threads on 6-in. pipe with a
"BEAVER"
ADJUSTABLE DIE STOCK

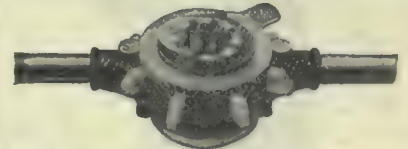

No. 6, threading 1-4, 3-8, 1-2, 3-4 in. complete. No changing of Dies or Bushings.



No. 25B, 1 in. to 2 in., R.H. complete.

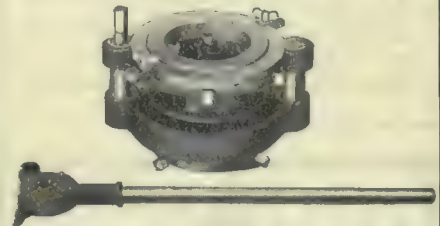

No. 60, cuts 2 1/2, 3, 3 1/2, 4, 4 1/2, 5, and 6 inch pipe.

NOTE—That with the three tools shown above you can thread from 1-4 in. to 6 in. pipe. No loose parts.



No. 41, cuts 2 1/2, 3, 3 1/2 and 4 in. pipe.



"WARREN" DIE STOCK
(Non-receding dies—adjustable.)
Each stock cuts two sizes. Made in four sizes.
Prices \$5.00, \$5.50, \$6.00 and \$7.00.

THEY SAVE TIME AND MONEY
Write for our Illustrated List

Borden-Canadian Co.
Richmond St. East, Toronto, Ont.

BENCH POWER PRESS

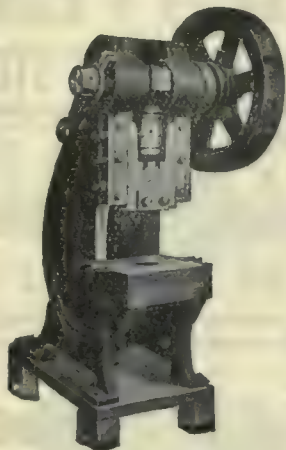

New Design

Particularly adapted for small, quick work, to take place of foot presses.

Write for Prices.

W. H. Banfield & Sons

MACHINISTS, DIE AND TOOL MAKERS
120 Adelaide Street West
TORONTO . . . CANADA

DO YOU KNOW the intrinsic worth of the IMPERIAL CHUCK?

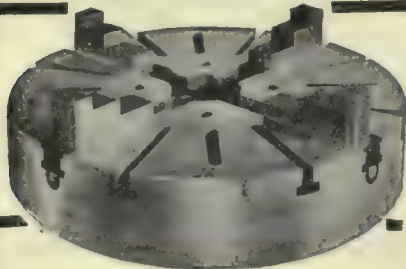

To give you an opportunity of proving our claim that it is the most satisfactory chuck on the market, we will send you one on

30 Days' FREE TRIAL

Use it freely, test it any way you can think of, and if it doesn't answer every call made on it, send it back at our charge.

We have faith in the "Imperial"—you'll swear by it too after you have used it and proved it.

Write us to-day.

Ker & Goodwin
Brantford, Canada

facture of wood fibre. The building will be of concrete and machinery of the latest type will be installed.

Fire broke out May 18 in one of the drying kilns of the Rider & Kithener factory, situated on George street, Lindsay, Ont. The kiln was full of veneer at the time. The extent of the damage will approximate \$2,000, partly covered by insurance.

Dickenson & Scott, New Westminster, B. C., have almost completed the erection of a new sash and door factory at North Vancouver. The factory is being equipped with the latest types of machinery for the manufacture of interior house finishings.

The A. R. Rodgers Lumber Co., Enderby, B.C., will operate their mill both night and day during the present season. Extensive improvements have been made to the mill, two carloads of machinery having been installed during the last two months.

O'Neil's planing mill, shingle mill and chopping mill, Kenilworth, Ont., were totally destroyed by the explosion of a defective boiler. The loss of the mill at this time will be a serious one to the owner, as he has several contracts for the coming season.

The Emerson Lumber Co., Port Moody, B.C., have sold to the National Finance Co., 3,000 feet of Burrard Inlet water frontage, near Port Moody, for \$600,000. The Emerson Lumber Co. will have the use of the property for three years to give them time to secure a new site.

A statement has recently been issued by the Hastings Sawmill Co., Vancouver, B.C., showing an exportation of 34 million feet of lumber to foreign points this year. The largest consumer was Australia. Chili was the next largest customer. The value of the product exported was \$472,200.

New Companies.

The Standard Brick Co., Toronto, capital \$25,000, has been incorporated. Incorporators are Charles A. Miller, G. J. Steele, R. W. Pike and L. Wright.

Crown Electric Mfg. Co., Brantford, capital \$200,000 to manufacture electrical appliances; Incorporators: J. S. Dowling, J. H. Ham, J. Ruddy, Brantford, and F. J. Mosedale, St. Charles, Ill.

Dominion Pacific Lumber Co., Montreal; capital, \$3,500,000, to manufacture and deal in timber and wood of all kinds. Incorporators, H. A. Lovett, G. V. Cousins and P. F. Brown, Montreal.

The Atlantic Coal Co., Maccon, N.S., capital, \$290,000, to explore, work and develop coal mines, Incorporators, R. O'Leary, Richibucto; W. S. Montgomery, Dalhousie; T. Nagle, St. John.

The Canadian Malleable Iron and Steel Co., Toronto; capital \$500,000; to manufacture and deal in iron, steel and other metals. Incorporators, J. A. Brown, J. H. Alexander and E. S. George, Toronto.

The Granville Power Co., Ottawa; capital, \$1,500,000, to work, maintain and manage gold, silver, copper, nickel, lead, coal and iron mines. Incorporators, F. H. Chrysler, C. J. Bethune, M. G. Larmonth.

Atlantic Sugar Refining Co., Montreal; capital, \$4,500,000; to manufacture, refine, buy, sell and deal in sugars, syrups, and molasses. Incorporators, A. Chase-Cosgrain, J. W. Weldon, E. M. McDougall, Montreal.

The A. H. Coplan Co., Ottawa; capital \$60,000; to manufacture and deal in new and waste metals, rubber, paper stock, babbitts and all kinds of base metals. Incorporators, A. H. Coplan, H. Pullan and M. P. Walters, Ottawa.

The Laurentian Chemical Co., Montreal; capital, \$590,000; to produce, manufacture, buy and sell wood alcohol, alcohol, turpentine, charcoal and tar. Incorporators, A. D. Gall, F. E. Lovell and W. Galbraith, all of Montreal.

The Westport Manufacturing and Plating Co., Westport, Ont.; to manufacture and deal in gas lighters, electrical fixtures, electroplating work and electrical goods. Incorporators, F. F. Dies, W. C. Whitchee, S. A. Conklin, Ottawa.

Seller's Anchor Bottom Tie Plate Co., Quebec; capital, \$100,000, to manufacture and deal in tie plates, railway supplies and iron

and steel specialties of all sorts. Incorporators, R. J. Mercer, S. W. Jacobs and A. R. Hall, Montreal.

The Dominion Estate and Mining Investment Co., Cobalt; capital, \$50,000; to mine, smelt and amalgamate, asbestos, minerals, ores or metallic substances. Incorporators, C. G. D. Kelley, G. F. Greener, J. J. Anderson, Cobalt.

The Tutshi Lake Mining Co., Dawson City, Yukon Territory; capital, \$1,600,000, to refine and smelt gold and other minerals produced from quartz mining. Incorporators, W. O. Oppenhoff, M. Devig and N. Krings, Dawson City.

Blaugas Company of Canada, Montreal; capital, \$3,500,000, to manufacture, buy and dispose of all kinds of gas, electricity, illuminations, or any source of light, heat or pow-

Iron Castings

Any size up to 10 Tons.

TOUGH, GREY IRON CASTINGS, STRONG AND EASILY MACHINED.

Every Casting Guaranteed.

Wm. Hamilton Co., Ltd.
PETERBORO, ONT.



Canadian Hart Wheels

412 Barton St. East, Hamilton

Corundum and Emery Wheels
Grinding Machines, Beaver
Oil Stones.

OPAL GLASS TILING

FOR WALLS OF

MACHINERY AND POWER HOUSES

Most approved material.

TORONTO PLATE GLASS IMPORTING CO'Y

PLATE AND WINDOW GLASS

135 to 143 Victoria St., - Toronto

MAPLE LEAF

STITCHED COTTON DUCK

BELTING

DOMINION BELTING CO. LTD.

HAMILTON CANADA

er. Incorporators, M. B. Davis, J. A. Jacobs, R. Cooper, Montreal.

The Burroughs Falls Power Co., Ayer's Cliff, Que.; capital, \$50,000, to carry on the business of an electric light, heat and power company. Incorporators, W. Brauit, Sherbrooke; J. O. Brousseau, of North Hatley, Que.; W. G. Libby, Coaticook, Que.

Swanson Bay Forests Wood, Pulp and Lumber Mills, Ottawa; capital, \$1,500,00; to carry on business as pulp, paper, timber and lumber merchants, sawmill proprietors and timber growers. Incorporators, W. L. Scott, C. H. MacLaren and A. G. Ross, Ottawa.

The Railway Asbestos Packing Co., Montreal; capital, \$100,000; to develop and work asbestos mines, and to amalgamate and treat explosives, ores, metals and minerals. Incorporators, A. Warrell, St. John, N.B.; D. Rousseau and L. Turgeon, Sherbrooke, Que.

The Red Diamond Polish Co., Ottawa, capital, \$40,000; to manufacture and deal in metal polish, stove polish and all other kinds of polish, paints, oils, varnishes, cleansers and fillings. Incorporators, S. E. Adams, F. W. Birkett and C. J. Rattray, Ottawa.

The Cobalt Smelter, Montreal; capital, \$2,000,000, to explore and search for mines and ores of every kind, and to carry on the business of a mining, milling and refining company in all its branches. Incorporators, G. A. Mooney, L. J. Boileau and N. Brunet, Montreal.

Electrical Notes.

An electric light by-law was carried at Regina.

The electric light by-law at Fort Frances was carried.

The power by-law for \$85,000 has been passed at Stratford.

A by-law to give the electric light company a new contract was carried.

An electric light system will be installed at Yorkton, Sask., to cost \$24,000.

A by-law was carried at Ingersoll, Ont., to buy the electric light plant for \$39,800.

A power house is being erected at Port Elgin by the Sackville Electric Light Co.

An electric lighting system will be installed in the town of La Tuque, Que., to cost \$50,000.

Goldie & McCulloch, of Galt, were awarded the contract for a new boiler for the Mt. Forest electric light plant.

Walter Mitchell, of Port Stanley, will supply 600 poles for the Hydro-Electric transmission line at St. Thomas.

M. A. Maxwell, of Boston, has been asked to draw plans and specifications for an electric plant at Camrose, Alta.

The by-law authorizing the expenditure of \$25,000 for a municipal electric light plant at Estevan, Sask., has been passed.

The Brockville ratepayers voted the light and power department \$50,000 for the purpose of improving and extending the town lighting system.

The Western Canada Power Co. are planning to commence the manufacture of electric power at its new power plant at Stave River Falls, B.C.

The Fort Saskatchewan, Alta. ratepayers will be asked to vote on the expenditure of \$10,000 for construction of electric light plant on Sturgeon river.

At a meeting of the Merritt Electric Light & Water Co., at Merritt, B.C., it was decided to install a modern electric lighting system costing over \$15,000.

The Lloydminster, Sask. ratepayers ratified a by-law passed by the Town Council granting a franchise for eight years to W. Johnson for the operation of an electric light plant.

The Moose Jaw, Sask. ratepayers voted in favor of street railway franchise, which goes to a company composed of Ottawa capitalists. An up-to-date system will be installed at once.

The work of constructing the Niagara Power transmission station at Woodstock city is progressing rapidly and it is expected that the building will be completed in the near future.

Plans have been prepared for the development of a water power on the Coaticook river about a mile below Waterville, Que. Of this, 250 horse power will be required to

MALLEABLE IRON CASTINGS

PRATT & LETCHWORTH CO.
BRANTFORD ONTARIO

ALUMINIUM

You can
now get your Al-
uminium requirements

promptly attended to by our clients,
The British Aluminium Co., Limited, of

London, the largest pro-
ducers in the United Kingdom.

INGOTS, BARS,
SHEETS, RODS,
ANGLES, ALLOYS,
NOTCHED BARS,
CORNICES, WIRE,
CHANNELS, ETC.

Sole Agents for Canada: Parke &
Leith, 205 Yonge Street (Bank of
Toronto Building) - - - Toronto.

"The 20th Century Metal"

Lightest and most adaptable of the industrial metals. Fills a hundred purposes where the ordinary metals fail. Saves its cost over and over again by its lightness and easy working qualities

To-day get Bulletin "D" on the varied uses of ALUMINIUM (Parke & Leith)

JESSOP'S BEST TOOL STEEL "ARK" High-Speed Steel

THE FAVORITE BRANDS WITH USERS OF GOOD STEEL.
A LARGE ASSORTMENT OF SIZES IN STOCK.
JESSOP'S HIGH-GRADE FILES AND RASPS.

80 Bay, St., Toronto, Ontario
Chas. L. Bailey, Agent.

Jas. Robertson Co., Ltd
Montreal, Quebec

Reid-Newfoundland Company
St. John's, Newfoundland.

Jas. Robertson Co., Ltd.,
St. John, New Brunswick

WM. JESSOP & SONS, Limited, Manufactory, SHEFFIELD, ENGLAND.

You've got to use crucibles; are you sure you are using the best? Do you know you could increase efficiency in your foundry?

DIXON'S CRUCIBLES

have been standard for over eighty years. Think a moment what your fifteen or twenty-five years of experience means to you—and we've had eighty years of crucible making. Doesn't this justify at least a trial?

WRITE OUR CRUCIBLE DEPARTMENT.

JOSEPH DIXON CRUCIBLE COMPANY

JERSEY CITY, N.J.

THE BEYER WATCHMAN'S PORTABLE CLOCK



IS TAMPER PROOF
and thoroughly reliable

Shall we send
Particulars?

G. C. BREDIN, Sales Agent
252 Dundas St. London, Canada
Record Dials furnished for all machines.

STAMPINGS

Special
Manufacturing
to Order

No matter how hard a stamping problem you put up to us, the chances are we can satisfy you. Many people use stampings in place of castings and find them more satisfactory and often cheaper. Send blue prints and samples and let us quote you.

The Silent Partner is an interesting little magazine. We send it free—when there's a reason

THE GLOBE MACHINE & STAMPING CO.
800 Hamilton Street, Cleveland, O.

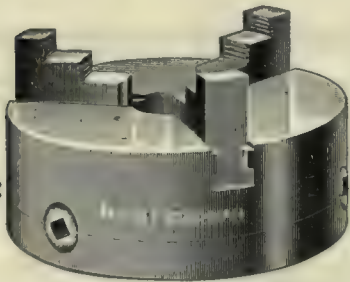

"CUSHMAN" CHUCKS

For general machinists' use.
Strong and durable and
designed for hard service.

Our catalogue shows many
styles and sizes and is sent
free. : : : : :

The Cushman Chuck Co.
Hartford, Conn., U.S.A.
Established 1902

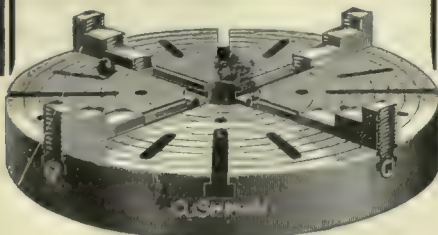

operate the factory of Geo. Gale & Sons, and the company will also light Compton as well as Waterville.

New Westminster, B.C., is looking into the question of power supply from a falls near Harrison. The falls are capable of developing 25,000 horse power. Three miles of piping will give a fall of 1,500 feet.

By-laws to raise \$39,000 for the purchase of power plant, etc., and another to provide a sum of \$15,000 to augment equipment and prepare for distribution of electricity will be submitted to the ratepayers of Ingersoll.

The Bergmann Electric Works, of Berlin, Germany, have established a branch office in Montreal. They are now feeling their way towards opening a factory for making the Tungsten lamp. Dr. C. Rossner is representative.

The report that the C. P. R. will electrify the Crow's Nest Pass line is revived by the statement of an incorporation of a company capitalized at \$1,000,000 to develop power from the Pend D'Oreille river at its junction with Salmon river.

Work has been started on the construction of a concrete dam seventy feet high across the cascades at St. Alban, Portneuf, where three hydro-electric units will be installed with a capacity of 750 horse power each. Power will be distributed to eight villages situated between Ste Anne de la Perade and Portneuf, Que.

The Dominion Power & Transmission Co., Hamilton, intend making a number of changes in the operation of its subsidiary companies. The street railway system will be centred at the new barns that are being built on King street east, with Fred Griffiths in charge. A big open-air switch is being installed at Bartonville to control the power lines from Decew Falls.

The Western Power Co. expects to generate 80,000 when their plant is completed. The first power is now being generated at Stone River Falls and will be used for work in connection with their power plant and dam construction and for the running of locomotives between Stone River Falls and Ruskin. It is expected that power will be delivered to Vancouver early in 1911.

The city of Vancouver has adopted a system of lighting of the principal thoroughfares by light standards, which will be ornamental as well as useful, and which are something on the same pattern as those of other Pacific Coast cities. The business men started the movement, and will pay for the installation of the standards, which will total \$46,908, and after they are in place, the city will pay the lighting bill.

The contract for pole line supplies for the Toronto Hydro-Electric System was awarded to the Canadian H. W. Johns-Manville Co., at \$1,157. Wire required for the Hydro-Electric System will be supplied by the Northern Electric & Mfg. Co., at 16.5 cents a pound. The Safety Insulated Wire & Cable Co., of New York, were awarded the contract for laying conduits under the crossings in connection with the installation of the Toronto Hydro-Electric System.

A company in which Vancouver capital will be largely represented is now being formed for the purpose of establishing a large electric lighting and power plant in the upper Okanagan valley. It is stated that plans have been so far matured that incorporation of the company will be completed at an early date. The principal business of the new company will be the construction and operation of lines of electric railway which, according to present plans, will radiate from the town of Vernon, B.C.

Trade Notes.

Chapman & Walker, engineers and contractors, 69 Victoria St., Toronto, have opened offices at 429 Coristine Bldg., Montreal.

The Holden Co., general railway and contractors' supplies, has removed its head office in Montreal from 302 St. James St., to 354 St. James St.

The Dominion Wire Rope Co., at its annual meeting in Montreal recently, re-elected the directors, the organization for the current year being as follows:—President, F. W. Fairman; Vice-President and Man-

SPECIAL MACHINERY, Etc.

ARMSTRONG BROS.

16 Sheppard St., Toronto
Mfrs. of SPECIAL MACHINERY
Patents Perfected
GEAR CUTTING, TOOLS, DIES, ETC.
Ruching and Pleating Machinery.

ERNEST SCOTT

91 BLEURY ST., - MONTREAL
Machinist and Tool-maker
Dies for sheet metal work. Stampings and light manufacturing. Special machinery designed and made to order.

The PARMENTER BULLOCH CO., Ltd. GANANOQUE, ONT.

Iron and Copper Rivets, Iron and Copper Burrs Bifurcated and Tubular Rivets, Wire Nails, Copper and Steel Boat and Canoe Nails, Escutcheon Pins, Leather Shoe and Overshoe Buckles, Felloe Plates.

OWEN SOUND IRON WORKS, LIMITED OWEN SOUND, ONT.

Cement Mill Machinery, Boiler and Steel Tank Work of all kinds, Grey Iron and Brass Castings

PATTERNS AND MODELS

PATTERNS IN WOOD

~ ALL KINDS ~

Difficult Core Work a Specialty
High Grade · Right Prices · Prompt Delivery

SATISFACTORY WORK GUARANTEED

THE HAMILTON PATTERN WORKS
258 CATHERINE STREET NORTH
HAMILTON, ONT.

PATTERNS

Patterns and Models All work guaranteed.
of any design. Correspondence Solicited.

JAMES SIBLEY

Mechanical Draughtsman and Patternmaker.
156 DUKE STREET, TORONTO
Phone Main, 5747.

YOUNG machinist or technical graduate wanted to travel. Must be good talker and resourceful. No previous traveling experience necessary. Splendid opportunity for ambitious man to work into a good position. Apply

BOX 101
Canadian Machinery
Toronto

The Effect of the Automobile Industry on Machine Tools

This Topic was Discussed before the National Machine Tool Builders' Association
—The Automobile Industry has had a Marked Effect on Machine Design.

By Robert Pierpont.

Where we are making automobiles there is a great saving in the use of special machinery, even if used for but one season. The large output of one model helps this, as we could well afford to spend thirty thousand dollars to experiment and make the tools for a rear axle if we were making twenty thousand cars, as it would mean only \$1.50 per car, and would save several times that, but on one thousand cars it would be \$30 per car.

In regard to special machinery designed for special purposes, it has usually been considered by a salesman a good argument to say that the entire cost of the machine can be saved in one season's business, in comparison with the cost of doing the same operation on a standard machine. I am strongly in favor of special machines, which do pay for themselves in this way, provided they are simple and easy to operate and not liable to get out of repair.

We have two extremes of opinion in regard to special machinery. A friend of mine, who formulates the policy of a large automobile concern, keeps selling his old machinery to buy new as fast as something which he thinks is better comes out; consequently, he does not believe in very much special machinery, as he would not be able to sell it as readily as he does the standard tools. Others go to the other extreme and will buy special tools for everything, as fast as they come out, whether there is much of a saving or not. I hardly think either extreme is the better policy. It seems to me there is a large field for standard machines somewhat simplified, to be used for special purposes, these to be sold at a cheaper price in quantities, but so built that the full complement of attachments could be added at any time desired. This brings up a point which I wish to emphasize, which is "Simplicity."

Simple Machines Needed.

In Michigan we do not have all high-class mechanics, but are forced to bring in farmers' boys, and even the farmers themselves, during the winter months, and try to make machine men out of them. A great many of the machines which we have are so complicated that it takes a long time for such men to learn to operate them. With the rapid increase of manufacturing and the great demand for machinists, it is almost impossible to get enough competent men to run the machines properly. I think

we need simpler machines with fewer feeds and speed changes, rather than machines more complicated and complete. In the ordinary use of machinery it is not necessary to have quick change of gears, as the majority of our men run day after day on the same piece or cut, and in getting out pieces in large numbers it is more advantageous to keep a man doing a certain piece of work, as he is apt to do better and more pieces the longer he is at it. The adjustments of the bearings should be simple and easy to understand and operate. Good foremen are getting scarce and we need machines which will require but little attention.

Referring again to the gearing of the machines, both for driving and speed changes, I notice that our machine shops are continually getting more noisy, and I think you will all agree that when we want a man to do a really nice job, we get him off in some quiet place to work. The noise of the gears running and shifting attracts the attention of the men from their work, and it takes them a long time to get used to it, especially is this true of unskilled labor. This is another reason why I would favor a more simple machine, which would also be more quiet in operation.

Still another reason why I am in favor of the special machine for doing the work faster and more accurately is in taking care of repair parts. The time is already here for some of the automobile manufacturers, and will come to all of the large producers, when they will not be able to take care of the repair parts for outstanding cars in the regular production machine shops, but will have to make special departments, where these repair parts can be produced. If we have any special machinery used in this year's produce, but not in next, we can turn this machine over to that repair department and continue to make these pieces at a cheaper cost than could be done on standard machines, which will all go to help the upkeep for the car owners.

I think a wise plan is, instead of selling old machinery, to which all the special tools and fixtures have been fitted, to turn these over to the repair or parts manufacturing department and buy more new and special machinery for equipment for the coming season's cars. I am sure you gentlemen will all agree with me in this, as the laying aside of the old machines and buying of new

will be fine for the machine tool business. This, as you can see, would not be a hardship for the manufacturer of cars, if he buys the special machines and tools with the knowledge that he will more than save their cost in the season's run.

Motor-driven Machine Tools.

I imagine the question of the direct connected, or motor-driven machines, is receiving considerable attention at your factories. It has always seemed to me that special machinery, or that adapted to doing one thing, was the ideal tool for a direct-connected one, as the load will be fairly constant. It very often happens that a special tool will do so much work that it will be necessary to run it only part of the time. If motor-driven it could be shut down for the remaining part of the day without cost.

It does not seem practical to me to equip all standard machines with motors, as on a standard machine, the work varies in style, quality, and power necessary to accomplish the desired result, as at one time we might be using only one h.p. and at others 10 to 15, or whatever the capacity of the machine might be. For example, if we took a room of twenty milling machines and equipped them all with $7\frac{1}{2}$ h.p. motors, the sum would be 150 h.p., whereas very likely the whole room could be run to better advantage with one 50 h.p. motor, and we would have the difference in investment between the twenty $7\frac{1}{2}$ h.p. motors as against one 50 h.p.

It is a well known fact, however, that the friction of the line shaft and belts is greater than the power consumed by the required number of small motors running idle, or the amount of current used to run the motors themselves in excess of the load of the machine.

In the remodeling and moving around which we have found necessary on account of the growth of our machine departments, we have been compelled to use motor-driven machines, as they could be placed in almost any position, and a great many times the room was not suitable for the hanging of shafting. I use the word "compelled" because I do not think anyone would lay out a machine shop for the special purpose of making automobile parts with the idea of using all motor-driven machines; or, in other words, not have a piece of shafting in the building.

However, here is another example where I would prefer a motor-driven

machine: We will suppose, in order to get out our output, we have to make twenty-five pieces of a certain kind in a day. Now, this operation of whatever kind, uses a regular or standard machine, but the tooling is special; and although it takes but 2½ hours to do the operation on the 25 pieces, on account of the difficulty in changing over the machine and the size of the piece, it is impractical to do more than that number per day. Now, although this is a standard machine, I should wish it motor-driven, as the power used to drive the countershaft, etc., with the wear and tear on belts for the remainder of the day, would more than offset the cost of the motor.

Character of Drive.

I may be mistaken, but I have always thought that the single pulley drive came as a natural result after the motor drive. Not from necessity, but just because it was very easy to put a pulley on where the motor was connected.

There are a number of machine tools built, which, under certain conditions, can remove an enormous amount of stock, but the jobs are very few on which we can use a machine to the limit of its power. On the great majority of pieces that go to make up an automobile, if we held the piece tight enough to remove the material as fast as the machine will cut it, we would spring the piece all out of shape. If we do not spring it in holding, it will spring when we let it loose. I have very seldom seen in actual use a cone-driven machine which would not do the work as fast as the piece or fixture would allow it to be done. As the single or geared machines must necessarily cost more money and wear and tear on the whole machine is greater, I am inclined to believe that in a few years we will, most of us, be of the opinion that the single belt geared drive was not the success which we had expected.

It is not many years since the cutting tool, or steel man, came around and told us that his steel would stand more than the machine was able to do, but I have not heard that remark passed in the last two or three years, which goes to show that the machines themselves have been perfected beyond the tooling point. It is all very well for a manufacturer to say that his machine will remove so many cubic inches of stock a minute, but in actual practice that does not interest us as much as to have a machine run 365 days in a year, if need be, without repair, and do one piece after another with perfect accuracy. As you see, I am not a very strong advocate of the single pulley drive over the old cone type.

Automobiles do not seem to be getting much cheaper in price, but we are

giving more horse-power for the same money. The tendency is toward larger bore and longer stroke engines, which mean larger and heavier motor parts throughout. This, of necessity, is reflected through the whole car. The requirements all along the line will be for heavier machine tools to take care of the increase in size and horse-power of the cars. We used to think that an engine with a 5-inch bore was a large car and mostly for racing purposes. In looking over a list of some of the American cars, I find there are forty-four makers of cars using engines with 5-inch bore or larger for the present, or 1910 season, in standard touring cars, and I feel sure that there will be more next year.

Milling Machines.

I think some fine milling machines are being built. They are very powerful, and have all kinds of feeds and quick-change gears for feeds, speeds, etc. Now these same machines are just like the universal milling machine, except that the table does not swing. As only a small part of the work done on a universal miller requires the moving of the swinging table, the machines are knee type and to all intents and purposes universal. As a rule, we use universal machines chiefly for tool work. The question I wish to raise is this: Do we need all of these attachments and feeds in the same machine? Why not make them optional?

Lathes.

The same thing applies to lathes. We buy lathes with all kinds of quick-change appliances, feeds, stops, etc., but do we really need them, or do we buy them because you force them on us against our will? We do, however, like the wide, heavy carriage, the large bearings and rigid tail stock. A lathe used to be a simple machine; it was one of the first, if not the first, on which we started the apprentice to work. Take a walk through almost any automobile factory and notice the character of the work the men are now doing. Notice how often they use the change gears, etc., in getting out a large quantity of work. You are getting lathes to a point where they are almost universal in scope, I do not think we want a shop full of universal machines, the greater part of the attachments on which will never be used. As it is now, it is like buying a universal grinder with all the attachments, extra spindles, etc., and putting on it work that should be done on the ordinary plain grinder. This would be the height of folly, for we would be getting no return whatever for our extra investment, and I am forced to look at some of the so-called standard machine tools which are being built at the present time in this light.

It is rather hard for us to expect the average man who cannot even read a micrometer to turn out accurate work on a complicated machine. We have been tied down to the old-established precedent that every lathe called for a large and small face-plate, steady rest, etc., but I think if we had lathes built that could be bought either with or without plain rest, compound rest, quick-change gears, or screw-cutting attachments, and still have these attachments so they could be procured and put on at any time, it would save us considerable money on our investment.

There is very little work we finish on a lathe now. No matter whether it is straight or taper, inside or outside, we invariably leave a little to grind, whether it is to be hardened or not. This makes the lathe only a roughing machine at the best, but it must be able to rough accurately and true, in order to leave a uniform amount to grind or finish.

The newer crank-shaft turning lathes have proven very satisfactory. A number of us have tried grinding from the rough, but have given it up one after another. We may start off with drop-forged cranks near enough to grind out readily, but the dies wear, and we have trouble, and eventually come back and rough turn them on the lathe. I think it will be a fine thing when we can finish them in a grinder from the rough in an entirely satisfactory manner.

Grinders.

The manufacturers of plain grinders are moving in the right direction by making their machines heavier. High-speed machinery must be heavy and stand firmly on the floor or foundation in order to be satisfactory. I do not think it pays to be saving with your iron in the designing of grinding machinery. The whole machine, bed, table, wheel carriage, etc., must be very heavy, enough so, at least, that it will not synchronize with the vibration of the spindle, or the result will be poor work. We buy these machines and put them to work and no doubt they do not get the attention they should, but we expect them to do good, accurate work, although they may not be adjusted to a fine point at all times. The same holds true in all classes of grinders, internal, as well as external, and with the large milling cutters and tools we have to grind—I think the tool and cutter grinders might be made heavier without losing any of their efficiency.

We are using water grinders in new ways more and more and find they give the cheapest finish, as well as the best and most accurate. This applies to soft parts as well as hard ones. They save quite an item in float files and emery cloth. A large part of the different

pieces that go to make up a first-class automobile have operations on them in the grinding departments at some time before they are finished and ready for the stock room. We want in the future to finish more and more from the rough casting or forging without any previous or roughing operation. This applies to round as well as flat surfaces.

Drills.

In the way of drilling and vertical boring machines, we have used, and shall continue to use, still more multiple and special tools. While we now drill ten, fifteen or twenty holes on one side of a piece, I see no reason why we should not be drilling as many more on the other side at the same time, just as we mill or turn a piece on two or three sides at the same time. These special and multiple drills make a very nice proposition for motor-drive, as the load is very even. High-speed twist drills are used by almost everyone, and all drilling and boring machines should be arranged to take care of this.

We are using the gang drill press in successive operations to good advantage, and on large and long holes are getting a very cheap production, as one man can run a number of presses in one gang or set. Strong and accurate interchangeable tools and fixtures, that would be almost, if not quite, universal in scope, for holding the pieces to be machined would be an added inducement for the purchase of the drills if they could be furnished in this way.

The engine cylinder has had more special machinery built for it than any other part of the car, but the crank case which carries it seems to have been neglected, except in the matter of multiple drills. I think there is a market for some horizontal boring and reaming machines with two or three spindles, having movable centres for boring out crank and transmission cases. On a crank case for an L motor we require two bars, and on a T motor case three bars for the crank shaft and cam shaft holes. As it is now, we buy a horizontal drill and have to equip special driving heads to run these bars and this also shortens the space on the bed of the machine. If such machines are made, I do not know of them and will say we are in the market for two or three right now.

Screw Machines.

On the automatic screw machine we want greater production with accuracy. We also want machines which require the minimum of repairs. In the hand screw machines we are looking for new and original ideas for holding and tooling the pieces for chuck work and second operation. Some of the large bar machines are going to prove to us that they can make gear blanks cheaper from the bar

than from the forging. The turret machine builders have the right idea in enabling us to buy the bare machine or with as many outfits or tools as we require.

Gear Cutters.

Regarding gear cutters I do not think of anything other than what I have said in a general way. I do think, however, that someone should get up a machine or attachment for grinding rotary gear-cutters and hobs, after they are hardened, so that they will be absolutely correct. It might make the cutter more expensive, but with the increased wear we get from high-speed steel they would be well worth the money.

Special Machinery.

As I have already told you, I am in favor of special machinery for doing one thing and that well and quickly. I will give you only two or three examples which perhaps you will not think of. We are all using square holes more or less in our transmission gears. There should be a good sale for a machine to bore out a round hole into a square one, within a reasonably close limit. This could be done either vertically or horizontally and does not seem to me to be a very difficult operation. We would be willing to run a sizing broach through if it were necessary, but when we have to broach out a long sliding gear hub made from high-grade alloy steels from the round hole, it is a long and seemingly unnecessary operation.

There are an enormous number of cotter-pin holes to be drilled in the ends of bolts and studs. I do not see why we should not put them into a hopper and have them come out all drilled automatically. The same is true of cast-lead nuts. I do not see why these should not be slotted by an automatic machine, as well as threaded.

Then we have the square shafts that fit in the same square holes. These should be ground with a form or master doing the flats and corners all in one operation, and in the same manner in which we are now grinding the cam shafts. After machines of this character have been perfected, I do not see why they should not be standardized and sold as such.

AUTO SECTION OF C. M. A.

The Canadian automobile manufacturers have formed a branch of the Canadian Manufacturers' Association, their object being the promotion of the automobile industry in Canada. The following executive committee was elected: T. A. Russell, R. S. McLaughlin, R. B. Hamilton, Fred Sager, Hugh T. Tudhope.

The executive will elect a chairman and a vice-chairman.

The present members are: The Ford Motor Car Co., Walkerville; Canada Cycle & Motor Co., Toronto; the McLaughlin Motor Car Co., Oshawa; the Reo Motor Car Co., St. Catharines; the Tudhope Carriage Co., Orillia; the E. M. F. Co., Walkerville; the Dominion Motors, Ltd., Walkerville; the Regal Motor Car Co., Walkerville; the Kennedy Motor Car Co., Preston.

MONTREAL BRANCH, C. M. A.

Lieut.-Col. Robert Gardner, of the manufacturing firm of Robert Gardner & Son, Limited, president of the St. Andrew's Society, has been elected to the chairmanship of the Montreal branch of the Canadian Manufacturers' Assn., for the ensuing year. Col. Gardner has for several years taken a very active part in the work of the association. He was first elected to the executive committee in 1901, and has sat as a member of that body continuously since 1904, taking a prominent part in its deliberations and a keen interest in all that pertained to the welfare of the Montreal branch, and the association as a whole.

RAPIDS PRINCE LAUNCHED.

The John Inglis Co., Toronto, have launched a new passenger steamer, Prince George, for the Richelieu & Ontario Navigation Co. The Rapids Prince carries twin screw triple expansion engines with cylinders 12½ inches, 20 inches, and two 22 inches diameter, by 16 inches stroke. Steam is supplied by one Scotch boiler, 14 feet 8 inches in diameter, 12 feet long, with the Howden system of forced draught and a working pressure of 170 pounds. There are six feed pumps and a vertical jet condenser. The boat is equipped with steam and hand-steering apparatus. It is lighted with electric light supplied by a Westinghouse direct connected 22 kilowatt generator of 250 volts.

CLUB FOR EMPLOYEES.

The Massey-Harris Co., Toronto, intend securing and operating a clubhouse for their employes, where tea and coffee could be served; a place, it is presumed, where the men could smoke and take their ease, offering all the inducements and companionship of a hotel, with none of its drawbacks.

James D. Grant, formerly of the order department, Frost & Wood Co., Smith's Falls, has accepted a position with the P. Burns Co., Calgary. He was presented with a gold watch by the Frost & Wood office staff and foremen before leaving for the west.

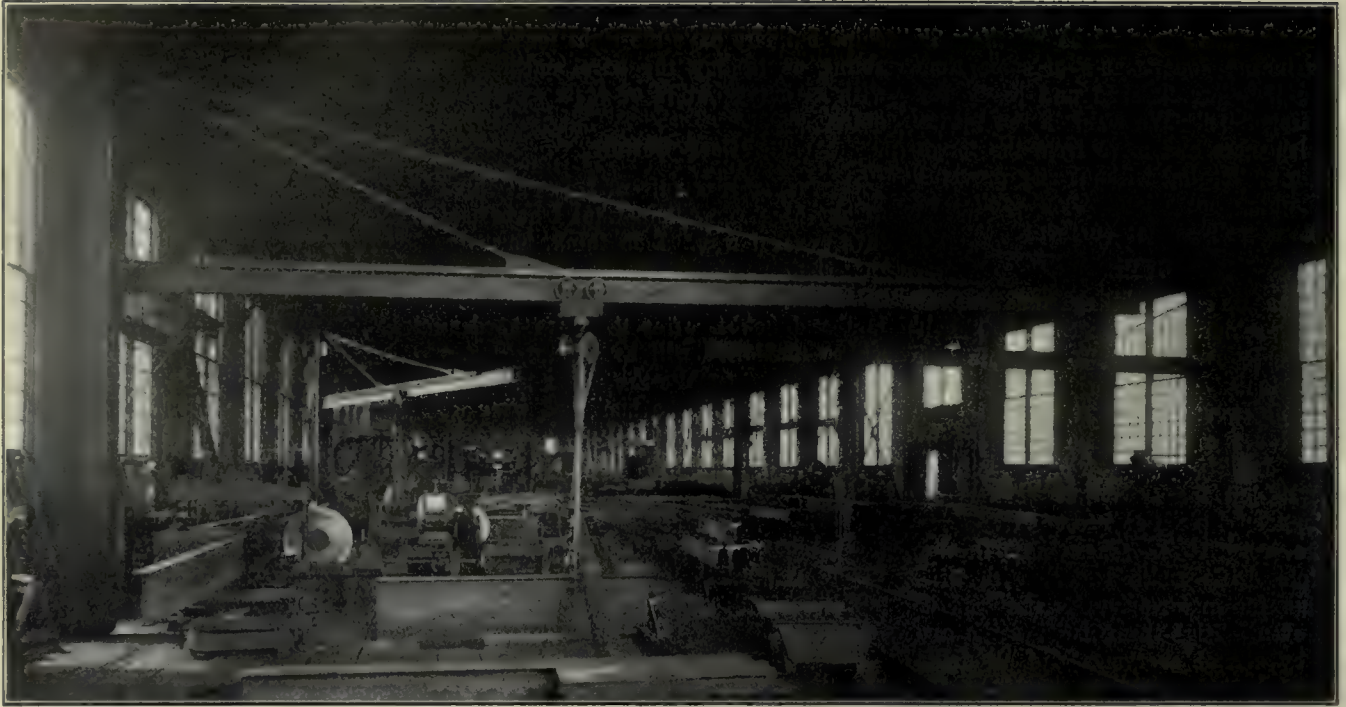

Interior Dominion Bridge Works, Toronto, Showing Facilities for Handling Material.

Solving Transportation of Material in Machine Shops

The Dominion Bridge Co. have Solved the Problem in their Toronto Works by Installing Jib Cranes, Two Narrow Gauge Tracks and a Standard Gauge Track.

There are several ways in which materials may be transported from department and through a machine shop. In the accompanying illustration is shown a series of jib cranes and tracks successfully used at the works of the Dominion Bridge Co., Toronto.

The shop is longitudinal in design and the work passes progressively through from the east to the west end where it is ready to be shipped. When new stock arrives it is brought into the shop on the standard gauge track and deposited at the east end. On the left in the view shown, are the Newton cold cut-off saws where the larger shapes are cut to lengths for the work for which they are designed. The smaller shapes are cut off on the Henry Pels machine. This machine is very rapid in operation and with the aid of a jib crane the shapes are quickly cut off to length and transferred to the next machines.

The shapes are next marked, punched, assembled, riveted and painted. In passing the work along the tracks and cranes are used. On the north side it is possible to pass the work along almost the whole length of the shop. Opposite the air riveting machinery near the west end one crane has been omitted, but could be easily installed if desired or if found necessary.

On the south side opposite this point is the air riveting apparatus. An overhead trolley equipped with an air hoist is installed and by utilizing this the work could be passed along from east to west end of the shop without depositing the work on the floor.

The narrow gauge tracks are used for passing the work along, the cranes being utilized for the machinery, and marking and assembling operations. When the work is completed a car may be shunted into the shop and the finished product loaded on the cars, the jib cranes being found useful tools for loading.

This arrangement is very efficient, the cranes being at the service of the operators at any time. The trucks, which may be seen in the foreground of the illustration, are in sufficient numbers so that there is no delay waiting for material.

PROBLEMS OF THE FUTURE FOR THE ENGINEER.

In a paper on "The Apprenticeship Course and the Engineering Graduate," published in the *Electric Journal* for April, Chas. F. Scott, consulting engi-

eer of the Westinghouse Electric & Mfg. Co., says in part:—

"Modern industrial life consists not merely in machinery and factories, processes and systems, but it includes the human element and brings together in a single organization and into a single community, men of all grades and types. To know these men, how they work and how they think, to understand their point of view, is an opportunity which the young engineer should not miss. The larger and more difficult industrial problems which will come up for solution during the next generation are not those of machinery, but of men. It is this relation which underlies much of the industrial, social and political unrest of the present. The coming engineer will have more and more to do with the handling and direction of men, and furthermore, his education and training, his natural relationship to industrial affairs, supplemented by a first-hand knowledge of conditions and of men, should make the engineering profession a useful instrument in working out the problems of modern life which are very largely the outcome of the new conditions which engineering itself has produced."

Semi-Annual Mechanical Engineers' Convention

Atlantic City Meeting, May 31 to June 3, 1910---Many Important Papers were Read and Discussed: "Comparison of Lathe Headstock Characteristics," "Improved Methods in Finishing Staybolts and Straight Taper Bolts for Locomotives," Etc., Etc.

At the sixty-first semi-annual convention of the American Society of Mechanical Engineers, at Atlantic City, several important papers were read. These included a paper on the stockless jarring machine, described in the February issue of Canadian Machinery. Prof. Walter Rautenstrauch, of Columbia University, gave a paper showing a comparison of lathe headstock characteristics.

Lathe Headstock Characteristics.

Many machines on the market have been redesigned to make the most efficient use of high-speed steels. These tools can be compared on many bases, but the one which the author believes the most satisfactory is that established on the basis of those characteristics of speed and torque which permit the most economical removal of shavings from a given class of material and a comparison of the speed and torque actually obtained with the standard characteristics will serve as a means for judging the efficiency of the headstock. In any machine a definite relation must exist between spindle speeds and accompanying torques that the machine may be adapted to efficient weight removal on all diameters of any material. The torque resulting from taking a cut varies directly as the diameter of the piece operated on and to keep the standard surface speed best adapted to the tools employed the spindle speed must be increased. The spindle speed varies inversely as the diameter of the work, and where it is desired to remove a maximum weight of shavings, the product of the speed and the torque should be a constant and the ideal speed-torque diagram is an equalateral hyperbola. The diagram may be used to determine the proper relations which should exist between spindle speeds and torque in a new design of lathe and also to determine the extent to which the speeds and torques of a lathe already designed conform to this standard. A number of lathes of different makers were selected and speed-torque diagrams plotted for each. An investigation of these diagrams showed that increasing the number of speeds regardless of the torque does not necessarily increase the lathe's adaptability to economical performance and that the amount by which the efficiency can be increased is not proportional to the additional speed changes provided.

In the discussion of this paper Carl G. Barth spoke of the use of slide rules in calculations regarding lathes. With reference to gears he stated that the

pitch diameter d for a 60-toothed gear

60

can be made equal to S —by the Brown

62

& Sharpe formula, allowing the outside diameter to be equal to the pitch diameter of a gear of two more teeth: $7.7 S$ is then the strength of the gear. Tools of proper cross section should be one-thirtieth the diameter of the swing.

A formula for the horse-power required by a lathe is often wanted; a good one he offered is one-third of the swing.

A paper was read on "Improved Methods in Finishing Staybolts and Straight and Taper Bolts for Locomotives," by C. K. Lassiter, of the American Locomotive Co., Richmond, Va.

Finishing Staybolts.

The staybolts in a boiler, more than any other part, are subjected to destructive stresses. These bolts were formerly cut to length, drilled for centres and threaded in engine lathes, but as this method was expensive, bolt cutters were substituted. The introduction of the lead screw in bolt cutters brought about a considerable improvement in pitch. The idea of conceaving the bolts or reducing them in the centre below the root of the thread was conceived with the idea of providing flexibility, and for many years the diameter of the bolt was reduced in an engine lathe after it was threaded in the bolt cutter. About ten years ago an automatic machine was designed for making side stays from the bar automatically, including threading and conceaving. In the drilling of staybolts, considerable trouble has been experienced with drills breaking and an automatic machine for drilling the holes before the stay is placed in the boiler has been devised, which has reduced the cost of this very considerably. The usual method of finishing straight and tapered bolts required a number of operations, but this has been changed by the use of a special vertical multiple spindle drill and a special cutter head. The latter is the essential means of producing these bolts cylindrically true to the axis, the machine being simply the means for driving and feeding the bolt. In connection with this special cutter a device has been perfected for performing the threading operation at the same time that the turning is done.

E. D. Meier, discussing this paper, emphasized that in boiler parts too good a material cannot be used.

Another paper of interest was one by H. L. Gaunt on the mechanical engineer's relation to the textile industry.

Mechanical Engineer and Textile Industry.

The textile industry has been brought to a high state of perfection without the aid of the mechanical engineer, and its machinery was developed by the mechanic before the mechanical engineer became a very important factor in the industrial world. The most important field of this industry that the engineer has entered is the power department. In this industry a wider gap exists between the financial interest which controls, and the help that operate, than there is in almost any other industry. The textile schools at the present time are doing much to fill this gap by supplying men who can act as a link between the two interests. The lack of such men in the past is undoubtedly responsible for some processes, such as handling cloth in a bleachery, which could be easily standardized and done automatically, being still performed expensively and inefficiently by hand. One of the specific things which the author has in mind is the forming of the pile where the cloth is "soured." The piles are formed by hand, and for subsequent processes portions of two piles may be joined to form one. The pieces of cloth thus become mixed and must be untangled.

To do this work more efficiently and less expensively the author has developed a machine consisting of an inclined chute with upturned ends and a bottom composed of a series of freely-revolving independent rollers. The cloth is fed into the stack and is carried by its own weight to the bottom. As the fabric rises in the receiving stack, the forward end of the pile is forced upward into the other end of the machine and is taken off at the rate at which it enters the receiving stack. These machines produce a marked saving in time and also a saving in the amount of floor space required.

Line Shaft Hangers and Bearing Improvement.

This paper by Henry Hess, president of the Hess-Bright Mfg. Co., Philadelphia, has for its object the description of a special hanger, and the results obtained from tests made on it.

The Sellers type of hanger, while well adapted for use with plain bearings, was not found practicable with ball bearings, because the spherical sections outside the box for it to rock on were too flat for the large diameter of the box containing the ball bearing. After laying out a number of forms of hanger on paper, a design was finally evolved, in which the box is supported and pivoted horizontally. The body proper is of channel section and is attached by a single bolt at each end. The bearing box is a central cast supporting ring bored to fit the outer race of the ball bearing and provided with cover plates at the sides.

This arrangement retains the lubricant and also excludes foreign matter. The ball bearings are free to move endwise in the box, but are clamped fast to the shaft so that the inner race cannot rotate. Special alloy steel is employed for the construction of the balls and the races.

An interesting discussion followed, the author explaining the various points brought up. Concerning the effect due to dust in concrete buildings he explained that dust will destroy ball bearings if it gets in, but it is easy to keep it out. Ball bearings are being run on dredges where they are 40 feet under water, and the water is kept out and the lubricant in by the form of bearing used. The Thompson Meter Co. has a concrete building in which no trouble is reported from dust. In a marble works ball bearings are running without any trouble, and in textile mills they are able to operate without any trouble from lint.

The heating of ball bearings is due to mechanical work imposed by misalignment. Its effect is not very evident in ball bearings. There is but a very small rise of temperature in a ball bearing even with an exceedingly heavy overload. Ball bearings will reduce friction 60 to 90 per cent. Lubrication and drip are partly taken care of by enclosing the bearing. The space for lubricant is so large and the amount required so small in ball bearings that they will run from three to five years without replenishing of oil. It is not a question of the lasting of the lubricant, but its gumming, and, all things considered, it is advisable to look after such a bearing at least once a year. Regarding the best method of supporting bearings in concrete buildings, the author referred to practice in a German plant, where they have placed cast iron channels in the ceiling with T-slots and about 3 feet apart, running lengthwise of the building. Across these other channels can be clamped, permitting the locating of hangers anywhere.

CANADIAN STEEL COMPANIES.

"The Steel Company of Canada" is the name chosen for the large Canadian steel merger, which includes the Hamilton Iron & Steel Co.; Canada Screw Co., Hamilton; Montreal Rolling Mills, Montreal; Canada Bolt & Nut Co., with works in Brantford, Toronto, Belleville and Gananoque. The company is capitalized at \$25,000,000, with headquarters in Hamilton. The provisional directors: Robert Hobson and C. S. Wilcox, of the Hamilton Steel & Iron Co.; Cyrus Birge, Canada Screw Co.; Lloyd Harris, Can-

ada Bolt & Nut Co., and W. M. Aitken, of the Royal Securities Co., Montreal, who represents the new holders of the stock of the Montreal Rolling Mills.

Improvements to the extent of \$1,500,000 will be made. The officers of the merger are: C. S. Wilcox, of the Hamilton Steel & Iron Co., president; Cyrus A. Birge, of the Canada Screw Co., and H. S. Holt, representing the Montreal Rolling Mills, are vice-presidents; and Robert Hobson, of the Hamilton Steel & Iron Co., is general manager.

The valuation at which various companies included in the Hamilton merger were taken over is given as follows:—Hamilton Steel & Iron Co., \$9,300,000; Canada Screw Co., \$4,000,000; Canada Bolt & Nut Co., \$2,100,000; Montreal Rolling Mills Co., \$7,650,000. The present capitalization of the Steel & Iron Co. is about \$3,000,000, so that the holders of stock will get three shares in the merger for every one they hold in the company.

President Plummer, of the Dominion Steel & Coal Co., confirms the report that the Dominion Co. will not enter into competition with the Hamilton merger by erecting nail and screw mills. This is in return for the concessions made by the Hamilton merger in giving up the name and probably deciding not to erect a rod mill at Hamilton. The merger of the Dominion Steel & Iron Co. and Dominion Coal Co. will be known as the "Dominion Steel Corporation."

The statement that the Dominion Wire Mfg. Co., Montreal, is to be included in the Hamilton merger is officially denied by the president, W. H. Farrell. Negotiations were on but no agreement could be reached, so the company will not join the merger. There has also been some talk of the United States Steel Corporation taking over the Dominion Wire Mfg. Co., the two interests being very friendly.

The work of the additions to the works of the Lake Superior Corporation is progressing favorably. It is expected that those now under way will be completed by December, 1910.

St. Paul capitalists are about to establish a steel plant and smelter near Cowley, Alberta. Winnipeg capitalists have turned over immense coal and iron deposits near Cowley to the syndicate, and the latter has taken an option on iron deposits for \$250,000. The ore is magnetite, adapted for manufacture of steel.

The Western Steel Corporation, who are to establish a plant on the outskirts of Vancouver, plan to erect blast furnaces, rolling mills, bolt works and nail and screw mills. In connection with the steel works the company will lay out a townsite on ground situated close to the plant. The projected town will

be patterned on general lines after the famous creation of the United States Steel Corporation at Gary, Ind.

RE-ROLLING OLD RAILS.

About four or five thousand tons of steel rails have just been re-rolled by the Provincial Steel Co., Cobourg, Ont., for the I. C. R., and at the present time from fifty to one hundred tons of rails are being turned out daily.

These rails were purchased by the Intercolonial Railway from the old Ship Railway between Fort Lawrence and Baie Verte. They were then placed in use on the I. C. R., and were afterwards torn up and sent to Cobourg to be re-rolled. The rails formerly were of the one hundred and ten pound variety, and have been reduced to eighty pounds. They were laid on the road a few years ago, and becoming somewhat worn were taken up and sent to the Provincial Steel Co., who have re-rolled them. The Provincial Steel Co. is one of the new industries in Canada, and this is the first work they have done for the Government road. The process used is called the McKenna process: Used rails are heated and then put through the rolls, thus making the rails practically new, but reduced in weight and size.

CANADIAN BOUNTIES.

An official statement of the iron and steel bounties paid by the Canadian government during the fiscal year ending March 31 last, shows total payments amounting to \$1,808,533. The total pig iron production was 740,244 tons. On 547,063 tons made from Canadian ore \$480,763 was paid, and on 193,181 tons made from foreign ore the bounty amounted to \$93,205. The production of steel was 740,390 tons and the bounty \$695,762. On wire rods \$538,812 was paid for an output of 89,802 tons. The list of recipients was headed by the Dominion Iron & Steel Co.

OTTAWA MINT EQUIPMENT.

There have been several additions made to the Government Mint, Ottawa, by James Bonar, Deputy Master and A. H. W. Cleave, M.E., mechanical superintendent. The orders were placed with Francis Hyde & Co., Montreal, for equipment for use in the refinery department, and includes a battery of five King fuel oil furnaces equipped with safety valves, etc.; two rotary oil pumps fitted with special gearing, suction and discharge pipes, safety valves, etc.; one 1½ h.p. a.c. motor, one 100 gal. fuel oil tank, one Sturtevant monogram blower with motor, and four burners and combustion chambers complete with firebrick.

The Patent Relation of Canada to the World

A Summary of the Articles of the International Convention for the Protection of Industrial Properties—Some of the Advantages Accruing to the Contracting States.

Realizing that a change in the conditions then extant, regarding international patent conditions, was advisable, in 1883, an invitation was extended by the Swiss Government to all the countries of the world to attend a convention at Berne, Switzerland, to discuss ways and means of making any necessary changes. This meeting gave rise to the International Convention for the Protection of Industrial Properties, the signatories of the articles then drawn up, giving themselves that name. The contracting states were Belgium, Brazil, France, Guatemala, Italy, Netherlands, Portugal, Salvador, Serbia, Spain, and Switzerland, and since that time, other countries have come in, so that from a report in January, 1909, the following additional states had bound themselves to the articles of the convention: Australia, Algeria, Austria, Ceylon, Cuba, Denmark, Dominican Republic, Germany, Great Britain, Hungary, Italy, Japan, Malta, Mexico, New Zealand, Norway, Serbia, Sweden, Tunis, Tobago, Trinidad, and the United States of America.

The Patent Act.

Substantially, the act is as follows:

1. The subjects of each of the states of the union shall enjoy, in the states of the union, all the advantages that their own laws grant them, as regards patents, industrial designs or models, trade-marks and trade names. This applies likewise to a foreigner from a non-contracting state having interests in one of the states of the union. He is treated as a citizen of that state where those interests are located.

2. Any person applying for a patent, industrial design or model, or trade-mark in any one of these states shall, in all the other states of the Union, enjoy a priority of registration, of twelve months for patents, and four months for industrial designs or models and trade marks.

3. The introduction by the patentee into the country where the patent has been granted of articles manufactured in any of the others states, shall not entail forfeiture; but nevertheless, the patentee shall remain bound to work his patents in conformity with the laws of that country into which he is introducing these manufactured articles, provided the period allowable before forfeiture for non-working in that country is not under three years, commencing from the date of application in that country.

4. All goods illegally bearing a trade mark or trade name may be seized on importation into any of the contracting states, at the request of the interested party or government. If seizure is contrary to law, the goods can be prevented from importation.

5. Each of the states reserves the right to make any independent contract or special arrangement with any other state whether that state is in the Union or not, provided that the new arrangement does not contravene the convention agreement.

These foregoing five paragraphs, while by no means giving the full particulars of the articles of the convention mentioned, nor of the amendments agreed to by the convention when it met again in Brussels in 1900, they nevertheless give the essential working parts, for the balance of the report deals with the details of carrying out the ideas embodied.

In view of the simplicity of the agreement, does it not seem strange that Canada, one of the coming countries of the world, does not belong to this Convention when practically all the countries of the world, both great and small have identified themselves with the movement.

Some time ago a committee of the Canadian Manufacturers' Association was appointed to investigate the matter and they brought in a report unanimously in favor of Canada becoming a participant, but apparently the matter has been let drop with the result that no action has been taken in the matter.

There are many advantages that would accrue to Canada from being a member of that Union. If a citizen of one of the contracting states desires a patent all that is necessary for him to do is to file an application with his own home government, and if it doesn't conflict, it is granted and his patent is not only protected in his home country under the patent laws of that country, but it is also protected for the period of twelve months in every other state of the union under the same laws as his home patent.

It is a well-known fact that to protect a patent in the principal countries of the world is a very expensive undertaking, costing in the neighborhood of \$600, depending on the number of countries where protection is desired. Under the laws of the union, the patentee can manufacture and market his goods for the space of twelve months and thereby find if there is to be a sale for his pro-

duct, having, so to speak a "trying-out" period. If his article does not find a sufficient sale to warrant the expenditure of protecting his patent in the other countries at the end of the allotted period, he is saved the expense of having done so originally.

This allowance of twelve months' grace permits of the patentee's product becoming so established in that foreign country that in many instances a patent would be unnecessary there.

Another value of the union lies in the fact that a prospective patentee will go where he can obtain the greatest protection at the least expense. This has a tendency to take otherwise Canadian patentees across the line where the protection of the union is afforded. This is made possible by the first article cited.

These instances show that Canada would derive a benefit if she will only participate.

In 1900 Canada did apply for admission; but she was refused on the ground that her patent laws would need revising. All the principal countries of the world had laws that would conform, or were made to conform, besides the numerous smaller countries, behind whom Canada does not want to lag. Yet, while she was refused on that ground, and while the Canadian Manufacturers' Association has reported in favor of it, no movement has been instigated tending to their revisal. It would be an inestimable boom to the manufacturer, and would no doubt help to promote international trade.

MANUFACTURERS AT PT. ARTHUR

G. M. Murray, secretary of the Canadian Manufacturers' Association, has completed arrangements with the Port Arthur authorities for the entertainment of the association on Sept. 12.

They will arrive in Port Arthur at 10.30 a. m. on two trains, and will be taken to the top of the new Canadian Northern Railway Hotel, from which a panoramic view of the harbor and city will be had. Afterwards they will separate into two parties, those wishing to go over the dry docks and the lumber mills, which are to the north of the city, and those wishing to visit the blast furnace and the Canadian Northern elevator. Boarding separate trains they will be conveyed to these industries, and upon returning, at 12.30, they will be tendered a luncheon on the hill crest.

At 2.30 p.m. they will embark on the yacht "Sigma" and be taken for a trip around the harbor, after which they will again enter their trains and proceed west to the annual meeting at Vancouver at 8 o'clock.

"Beaver" Quick Changing Chucks and Collet Sets

Some Interesting Tools Manufactured by the Hamilton Tool Co.—The Collets are Designed for Rapid Interchange of Drills, Reamers, Counterbores, etc.

The accompanying illustrations show a chuck and set of collets designed for the rapid interchange of drills, reamers, counterbores, etc., with the result that they have succeeded in practically converting a single-spindle machine into a

when grasped between the forefinger and thumb and pulled outward the catch is instantly released, thus freeing the collet and tool from the chuck, which still remains firmly in the spindle. A spring steel wire firmly seated in a groove

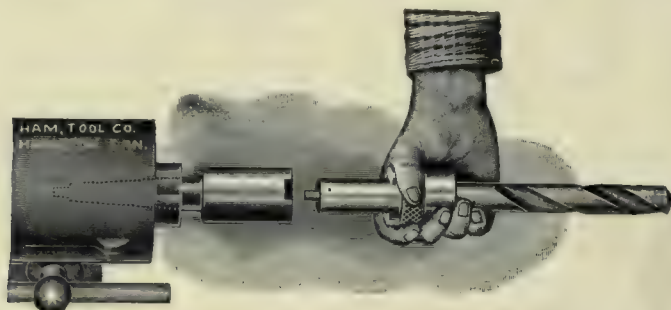

Fig. 1.—Drill Chuck and Collet, Hamilton Tool Co., Hamilton.

multiple spindle, as the collets and tools can be changed instantly while the machine is running at high speed. There is nothing to catch or shock the operator. These tools are made of high-grade tool steel throughout. They are simple in construction, positive in operation, and have proven great time-savers.

A self-contained device releases the collet and tool instantly, requiring neither hammer, wrench nor key to operate.

The chuck is fitted with a Morse taper shank of the required taper to fit the machine spindle and is bored so that each collet of the set will fit snugly into it.

The collets are bored to take tools having either Morse taper or straight shanks, as required. Lengthwise of the collet shank is set in, a strip of steel, which is kept in position by means of a spring. On this steel strip is a catch, which, when the collet is engaged, fits

around the collet prevents the knurled ring from coming off when being pulled outward to release the collet.

The sliding pin in the end of the collet is a very simple and most effective method of knocking out tools.

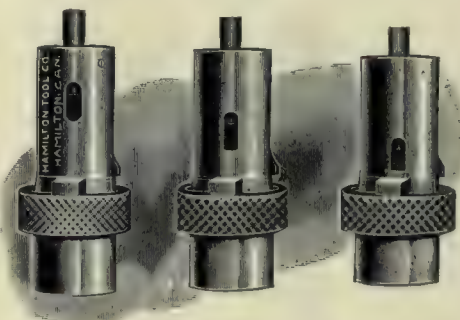

Fig. 3.—Drill Collets, Hamilton Tool Co.

To engage the collet grasp it by the knurled collar and push into the chuck.

To disengage the collet grasp it by the knurled collar and pull straight out from the chuck.

These chucks and collets are manufactured by the Hamilton Tool Co., Ltd., Hamilton, Ont.

TECHNICAL EDUCATION COMMISSION.

The following commission has been appointed by the Dominion Government: James W. Robertson, Montreal, Que., chairman; Hon. John N. Armstrong, North Sydney, N.S.; George Bryce, Winnipeg, Man.; M. Gaspard De Serres, Montreal, Que.; Gilbert M. Murray, Toronto, Ont.; David Forsyth, Berlin, Ont.; James Simpson, Toronto,

Ont. Secretary and reporter to the commission, Thomas Bengough, C.S.R.

The purpose of the commission is to be that of gathering information, the information when obtained to be carefully compiled, and together with such recommendations as it may seem expedient to the commission to make, to be published in a suitable report to be at the disposal of the provinces and available for general distribution.

The commission is appointed under the statute respecting enquiries concerning public matters, and will report the results of their investigations, together with their recommendations, to the Minister of Labor.

The Commission will begin by making a tour of the Dominion from the Atlantic to the Pacific, visiting all important industrial centres and ascertaining by personal enquiry and investigation, as well as by the hearing of evidence, the needs of employers and workmen alike as respects industrial training and technical education. Having completed this part of its work the commission will then visit the United States, the United Kingdom, Germany, France, and any other countries that may seem necessary, with a view to ascertaining the best methods by which similar needs are being met, and the work of technical education furthered in other lands. It is expected that at least a year will be required for this work.

Manitoba has also appointed a commission on technical education as follows: D. McIntyre, of Winnipeg School Board; one representative each from Brandon and Portage la Prairie school boards, and from Dauphin; one representative of the Manufacturers' Association, one from the Agricultural College, one representative each from the Brandon and Portage la Prairie Trades and Labor Councils, and about six from the Winnipeg Trades and Labor Council, and one from the Winnipeg Board of Trade.

FOUNDRYMAN'S RULE.

The Hamilton Facing Mill Co., Ltd., Hamilton, Ont., manufacturers of foundry facings and supplies, are issuing to their friends a two-foot folding steel rule, in a neat leather case, making it suitable for carrying in the vest pocket. In addition to the ordinary uses, the rule can be used for measuring the circumference of cones, patterns and castings. On release the rule at once regains its original shape. Any foundry foreman or superintendent may obtain one of these useful rules by writing the Hamilton Facing Mill Co., Ltd., on your company's letterhead.



Fig. 2.—Drill Chuck, Hamilton Tool Co.

into a groove on the inner side of the chuck, thus holding the collet and tool firmly in position. The inner side of the knurled ring is so constructed that



THE EASIEST PROFITS.

By James H. Collins.

A FOUNDRY in Ohio had been so busy for two years that, despite overtime work, it was constantly behind orders from a month to six weeks. Conservative advance estimates of the business that was being done placed the volume at half a million dollars, easily, and when the next annual accounting was made the gross output exceeded that amount. Yet it was learned that the profits for twelve months had been less than twenty thousand dollars. This discrepancy was so surprising that the concern called in a firm of production engineers to make a study of the business and find out where the profits had gone. Investigation showed that most of the loss came from congestion in the moulding shop, where castings were turned out.

This foundry make a wide assortment of machine parts for other manufacturers. Its business was secured chiefly on bids. The latter were based upon rough estimates. With no accurate cost system for following each order through the plant it was necessary to use averages calculated from last year's general cost of labor, materials, and so forth. The prices at which work was secured usually afforded a fair margin of profit. But that margin was frittered away in the processes, and for lack of a cost system which would show actual expense on each job it was impossible to locate the leakage. As each job came in it was numbered and sent through the plant in the order of its number. Thus, a lot of small castings would be followed by some very heavy ones, and those in turn by a dozen miscellaneous parts intended for a certain machine, all handled together under the same job number. As a result, the molders worked on a hodge-podge of stuff, big and little being cast side by side, and there was loss through confusion.

The production engineers laid out a system by which orders for several days were classified according to size. That made it possible to work the men on about the same-sized castings each day, giving the facility that comes in handling uniform work, simplifying the handling of flasks, pouring molten metal, and so forth. This immediately relieved the congestion that had put the foundry be-

hind its orders. Overtime work became unnecessary. Quality of output improved. Most important of all, it was possible to keep accurate cost records on each job, giving a surer basis for bidding.

For several weeks after this system was installed the engineers supervised its workings. The first definite information it yielded sent them to the management with suggestions about a certain kind of castings.

"You are losing money on them; raise your prices."

"Oh, we wouldn't dare ask higher prices for those," was the reply. "Our competitors crowd us too closely. It would put us out of business."

"Well, then, go out of business," said the engineers. "This work will put you

THE EASIEST PROFITS.

James H. Collins, the well-known writer of human efficiency stories, has contributed to *The Saturday Evening Post* a series of articles on *Business Economies*. The article on "*The Easiest Profits*" is abstracted from one of his series, in which he illustrates the work of the *Production Engineer*.

Lack of knowledge of costs resulted in a foundry in Ohio losing money. A study of the situation resulted in *prompt deliveries* and a *profit* on the work. The story impresses this fact—manufacturers must *know their costs*. What managers, superintendents and foremen must have is *business information* if they are to place the factory under their charge in a position to compete in this country's and the world's markets. This information can be obtained by studying and drawing up a scheme of administration, by which all the necessary *data, costs, etc.*, are brought to the *daily attention* of the *man-in-charge*.

into bankruptcy eventually, for you are losing money on all you turn out."

Why There Were Flaws in the Castings.

Investigation in the sales department demonstrated that contracts during the past two or three years had been made below actual cost of production, a condition brought about by lack of knowledge of true costs, coupled with timidity in the sales end. By sharp tactics customers had scared salesmen into meeting purely fictitious bids alleged to have been received from competitors. When prices on these castings were eventually raised little business was lost, showing that the competition had been largely imaginary, as a good deal of competition always is. At the end of a year this foundry was turning out three-quarters of a million dollars' worth of work. The plant had not been enlarged, nor was overtime labor necessary. Yet profits under the new system had been brought up to more than a hundred thousand dollars a year.

Some months after the system was running smoothly the production engineers were called in again. The foundry's percentage of defective castings had suddenly begun to assume alarming proportions. In the finishing-rooms many flaws were revealed despite most careful inspection of work turned out in the molding department, while some of the costly machine parts sold to customers under guarantees of quality were coming back almost daily, showing failures. For two weeks the engineers studied the establishment's whole routine, yet did not find anything that seemed to be out of the ordinary. The character of work was just as good as ever—better, in fact. Inspection of raw castings was very thorough, every piece that revealed the slightest defect being set aside as soon as it left the flask.

The engineers were puzzled. Finally a young chap on their staff, lately out of college, was told to stay at this foundry until he ran the trouble down, and he made it a point not only to work with the men in various departments, but to come down an hour or so before the whistle blew in the morning. One day he asked the superintendent a question:

"Mr. Walker, why did that molder over there take some castings from this

pile before he started work and place them on that pile?"

"Did he do that?" asked the superintendent, surprised.

"Yes—and other men did the same thing."

The trouble was cleared up immediately. Several molders, coming in early, had adopted the trick of lifting rejected castings off piles set out to be weighed and deducted from their day's work, reducing the defective pieces charged against their wages. Those defective castings had gone into piles of work inspected and passed, and a number had been shipped to customers. This is a typical instance of the production engineer's work in simplifying routine and saving profits.

The business doctor has long been familiar to the general public as a man called in when something is obviously wrong in a factory or mercantile house. Very often his service went no further than clearing up some specific trouble. Usually his chief interest was in accounting methods, and he departed after installing a card system of bookkeeping. But the production engineer takes the whole business as his province. He tests flue gases and coal, installs systems in the boiler-room and saves cost. In the engine-room he saves on lubricating oil. In the factory he tests materials, synchronizes processes, ferrets out costs, trains employees to better methods. At the executive end he takes routine work off the shoulders of the management, and at the same time gives them more facts about their business from day to day. The old-fashioned business doctor might be compared to the physician who is called in a hurry once or twice a year when some member of the family is sick, whereas the production engineer is like the Herr Doctor, common in Germany, who visits the family at least once a month, spends part of the evening chatting with its various members, and makes quiet studies that enable him to keep the family in pretty good health.

One of the best-known production engineers in this country began applying card systems to business years ago, when cards were hardly known outside of libraries. At the outset he adapted his cards chiefly to accounting. But soon he became interested in extending their usefulness. Making card-system payrolls, for instance, led naturally to recording miscellaneous data about labor and its costs on cards with different contours. That led, in turn, to gathering information about materials, processes, and so forth. By and by he woke up to the realization that the thing most needed in business is information—facts about men and management, materials and methods. Ninety per cent. of the concerns he investigated were operating on guess-work. So he began gathering business facts for others, interpret-

ing them, carrying out improvements indicated by them. To-day he has a large organization.

In the Interior Department at Washington an inquiry or other bit of routine business was referred to so many persons, with offices so arranged in a large building, that before it was finally disposed of it had traveled, perhaps, several miles, crisscrossing back and forth in a most confusing fashion. Production engineers studied those operations exactly as though they were factory processes; plating the routes taken by business, moving some departments nearer together and cutting others out of certain routine. When they finished the detail had been amazingly simplified and shortened. This same Government department has one hundred and four district land offices scattered over the United States. The records of each office were kept in a set of twenty-one different books, weighing upward of a hundred pounds. When the production engineers finished with that detail each office kept all its records in a single loose-leaf volume, so that there were only a hundred and four books as compared with nearly twenty-two hundred. These engineers are factory experts, and after making a typical factory study of the Interior Department, treating its business largely as a product, they made suggestions by which its operating expenses will eventually be cut down not less than half a million dollars yearly.

The Stock Room.

An old pottery, established more than half a century, had hundreds of designs in finished goods stored in its warehouse. An order for one hundred dozen pieces of a certain design was received and the shipping clerks hunted it up in the warehouse. Maybe they found only half enough goods to fill the order, so it had to wait while the plant turned out the other half. At the same time, perhaps five hundred dozen extra pieces of this particular design would be made up for stock and stored in the warehouse in readiness for future orders. After several months, however, the shipping department, searching for that design again would fail to find these extra goods, and another order was delayed while the plant made still more of them. This situation was put up to production engineers as a genuine puzzle, and they solved it very simply by installing a modern record of stock which facilitated orders by making it possible to make up goods before they ran short, and which reduced the amount of stock on hand by showing the frequency of orders for all designs. One very important item of saving was that effected by discarding designs that had not been called for in years.

In locating a disappearing margin of profit in a large foundry it was found

that all castings turned out were figured by weight, and bids made on that basis. Weight is no guide to cost in such products, for two different castings containing just the same quantity of metal may be of such unlike character that the labor cost of one may have actually been twice that of the other. This foundry was operating under a cost system that made it dangerous to raise the quality of its products, for its high-grade castings were being turned out below cost, and sufficient increase in the sort of patronage that should have been most desirable would have sent it into bankruptcy. The difficulty was met with a simple cost system that kept time, wage and material records on each job. In a few months the old margin of profit was not only restored, but increased, for the foundry secured more profitable contracts by being able to bid with absolute knowledge of costs, and thus had decided advantages over competitors.

These are typical accomplishments of the production engineer. Yet they are merely details. His study of a business extends to every department and function, and his conclusions are embodied in a complete report, usually a large, typewritten book with blue prints, forms and diagrams, each department having its separate chapter, with suggestions for economies. Such a report was prepared for a Government bureau at Washington. It contained so many suggestions for saving time, work and expense that the bureau chief had to ask Congress for a special appropriation to put the more important suggestions into operation. While he was waiting for his appropriation, however, he saved two hundred thousand dollars a year by carrying out some of the minor suggestions.

In another case the production engineers went through a large mill, making their report, and when it was submitted they called the president's attention to a little detail of accounting reform, the loss-and-gain account.

"Shortly you are going to be very much interested in this account," said they, and the president found it true.

Up to that time his plant had been operated wholly on information derived from an annual inventory, as is the case with many other concerns. This mill turns out several different kinds of goods. Going in the dark from one year's end to another, the president might be under the impression that he was making more money than last year, only to find that he had made less. Even if he gained in profits it was never definitely known which kinds of goods had earned the extra money, while, if a loss was shown he could not certainly put his finger on the item that caused it. The year is too large a unit upon which to transact business in these times—there are only twenty or thirty of such units in the

average business man's life at most. When the production engineers gave him a loss-and-gain account he had definite knowledge of each class of goods from day to day. Reports came from every quarter of the mill, were tabulated, and he could compare a given day's output with that of any other day, not merely in quantity, but from the standpoint of labor, raw materials, time consumed in processes, and so forth. If he wanted it this information could be presented to him in such ways that he alone knew the whole story.

At the outset this system was regarded with suspicion by foremen. Those exact reports, calling for detailed statements of each minute of time, every ounce of materials and every item of completed work, seemed a sort of spy system. But when results began to come in to the president and go back to the foreman in the shape of orders and suggestions the latter became as interested in the loss-and-gain account as himself.

In the old days, after an annual inventory, if there was a gain in profits the president would, perhaps, increase each foreman's salary, going largely by the number of years Tom and John and Bill had been with the mill. If there was a loss he called them all together and gave them a lecture on the importance of economy, diligence and other abstract virtues, and sent them back to work to find the cause of trouble and correct it. They had had no means of finding it, naturally—he couldn't find it himself.

But the loss-and-gain account changed all that. It showed definitely that on this batch of goods, made last week, the cost of manufacture had been three cents per hundred higher than the cost of identically the same quantity and kind a month before. The foreman responsible for those goods could be called in and given a chance to explain matters.

"Why, Mr. Smith, that low cost last month was on account of the way our enamel worked. We never had such a fine lot of enamel. Everything seemed to run like a dollar clock. But this month we're having trouble. The last job didn't go through as smooth."

"Well, now, suppose you experiment a little with your enamel. Send down to Biggs' laboratories and get a chemical analysis. If we can get that kind of enameling right along it will mean a good deal to us in the way of contracts."

This gave the foreman something definite to work upon. Under the old inventory system there were a thousand or more ratholes down which that three cents a hundred might have disappeared and nobody have been able to locate it. But the loss-and-gain account showed precisely the rathole to be investigated, and usually the foreman succeeded in plugging it up and trapping the rat. If

he set a standard of quality or economy he was held to it. But the president knew how great an advance such new standards meant, and knew who was entitled to credit. Soon there was a different spirit in that plant, because the men knew they were now working on accurate information and that credit for good work or blame for bad would fall exactly where it belonged. The engineers had planned a loss-and-gain account, but what developed when it was put into operation was a broad human principle that facilitated management from top to bottom.

The capable production engineer is far more than a systematizer.

Nine times in ten, after making his study and drawing up a scheme of administration, he stays with the latter until it is installed and running smoothly. If the new-fangled routine were all drawn up on paper and handed to Bill Jones in the boiler-room, with the statement that by following that method the company could save three per cent. of its fuel costs, Bill Jones might not think the matter important. But when there is somebody right on the job to insist that about forty dollars a week is being wasted up the chimney Bill Jones is interested.

He may also be called upon to take charge of business enterprises on behalf of creditors or heirs, to lay out large plants where capital is creating them from the ground up, to apportion different kinds of manufacturing among a number of plants following a large consolidation, to advise as to increase of capital, or find the valuation of property in disputes or settlements.

So he is more than an expert in accounting, costs, industrial chemistry, systems, or any other restricted specialty. In the course of the year he employs many such experts, and supplements their work with broad administrative experience drawn from manufacturing, trading, banking, Government business. For in dealing with production he is dealing with pretty much all industry.

SHOP SECRETS.

By John R. Godfrey.

The shop secret is a peculiar institution. Sometimes it is based on the idea that if the other fellow knew how we made our sausage stuffer, he might be a more vigorous competitor. The chances are, he is meeting our prices now, which indicates that he must be making them as cheaply as we are, so that his methods must be as good as ours, even if different. And there are nine chances out of ten that we wouldn't use his methods if we knew them, nor he ours, if he knew all about them. And the chances

are that we all know all about the other fellow's way anyhow, and prefer our own.

This method of ours has cost us a lot of money to develop. Meanwhile, the other fellow has been standing still and we've been getting all the business. But have we?

Isn't he still in the ring, wearing clothes as good as ours, and didn't we see him in his auto last Saturday at the ball game? Then somebody must have told him our way, because no one else could have thought of it.

Shop secrets are largely creatures of the imagination unless in a business so small that one man can do all the work and use all the secret methods.

When a workman leaves our shop, no matter what the reason, he carries in his head some of our ideas and methods. He can't help it. Some men carry more than others, some can impart more than others, but it doesn't do to fool yourself, as some do, into believing that the average workman wouldn't know an idea if he met it face to face. Don't get the idea that all the brains of any establishment are in the office, no matter who says so. If they were, there wouldn't be nearly so many successful businesses as there are to-day.

I was in a large shop recently and saw a new material being used for a certain part of a well known machine. "Sh! not a word, we aren't advertising that. The other fellow will catch on soon enough."

Strangely enough, I saw the same thing in the other fellow's shop the next day—said they had been using it for some time. The other fellow had caught on, but I wonder which one was first.

So I've come to this conclusion. When you get a new scheme, build a new machine or do something worth while, don't try to be over modest. Talk about it; let others talk about it—and use it after it's been talked about with your name hitched on to it.

I can name several types of machines which are to-day known by the names of men who do not claim to be the inventors. These men simply saw the possibilities of these machines, built them, talked about them and made other people talk, and they bear their names as long as they are used. And many users never heard of the original makers. If they had not been so backward in proclaiming their wares, it would have been a different story.—American Machinist.

Wm. Surdam, foreman of the molding department, Frost & Wood Co., Smith's Falls, has resigned to accept a position in Auburn, N.Y. He was presented with a Masonic ring and traveling bag when leaving.

MACHINE SHOP METHODS ^A_N^D DEVICES

Unique Ways of Doing Things in the Machine Shop. Readers' Opinions Concerning Shop Practice. Data for Machinists. Contributions paid for.

BALL RACE CALIPER.

The accompanying sketch represents a very useful tool used in the shops of the Canada Cycle and Motor Co., Toronto, and is an idea developed by the superintendent.

The discs are ground circular with bevelled edges, the exact diameter of

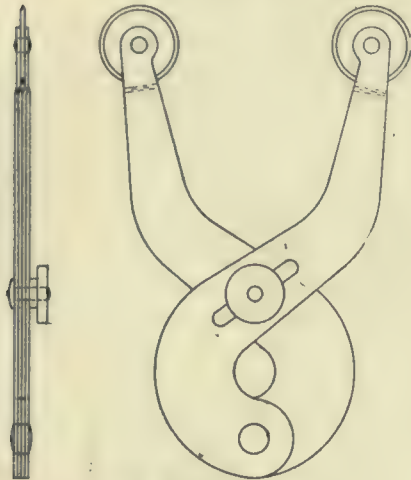

Ball Race Calipers.

the ball-races, and are formed of thin steel. The bevelled edge insures line contact, making observations easier. The body is made up of four thin sheet steel strips, riveted like ordinary calipers at one end, and clamped together in any position desired by a screw in a slot. Most of the ball race calipers in use by the company are not made as shown, but made fixed like gauges, by riveting where the adjusting screw is. The latter is a better method for multiple production of the parts. Quite a number of different sizes are carried.

CENTRE FOR TURNING PATTERNS.

In the machining of circular patterns, care is required, else the pattern will not be split exactly in the centre.

This little device is one in use by the Steven Co., Galt. It not only insures

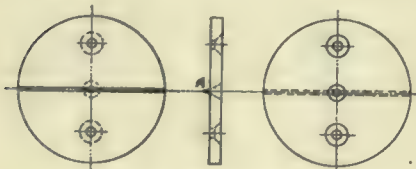

Centre for Turning Patterns.

the work being split exactly in the centre, but also facilitates the operation.

In general, it is almost exactly the same as the usual centring piece for

patterns, consisting of a flat disc, with a tapered hole for the centre, and two screw holes, securing the two halves of the pattern. The special feature is the knife edge projection, A, which is inserted at the dividing line of the patterns, making it impossible to have the pattern unequally divided. This edge, of necessity, must be very thin in order that the patterns might be tight together. Paring the parting edge slightly at the end insures this.

JIG FOR GEAR TEETH PATTERNS.

The method of forming patterns for gear teeth by shaving down to marked lines on the end of the block of wood is a very slow process, and entails considerable work to ensure any degree of accuracy. This is especially true with bevel gears.

The Stevens Co., of Galt, have devised a very simple jig for the rapid production of patterns, which is a great improvement on the old method, both in point of quality of work, and rapidity of production.

The jig consists essentially of a block of wood A, with tooth forms BB projecting at each end. These tooth forms are made the size of the tooth de-

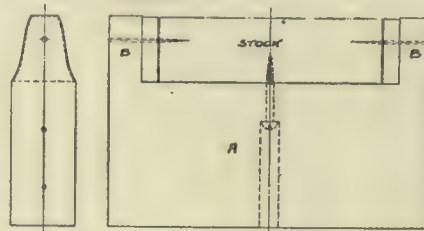

Jig for Gear Teeth Patterns.

sired, plus the thickness of a piece of sand-paper, all over. The actual size of the tooth is as shown by the dotted lines on the end view. The block of wood to be worked is placed between these forms, and held in position by the woodscrew below, and the two brads at the ends. The tooth stock is first reduced roughly in the usual manner by chiselling, until it is approximately D size, and then it is sand-papered on a revolving drum. The sand-paper is just slightly wider than the stock, so that the forms at the end press against the revolving drum, while the stock is reduced the thickness of the sand-paper below the size of the forms, making the desired size of tooth.

It has been found to be a very useful jig, and is adapted to all forms, being particularly useful for bevel gears. The

Stevens Co. carry a large stock of jigs for the various sizes, finding it a very economical process.

VALVE SEAT GRINDER.

This is a simple little device for grinding small valves to proper seats in a manner better than can be done by the continuously rotating method in general use. It is the method in use at S. F. Bowser & Co., Toronto, and was devised by their superintendent.

The basic principle is that a better

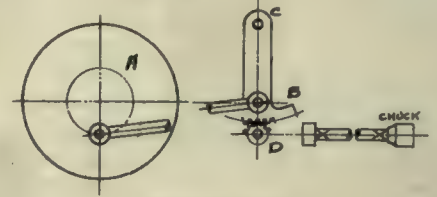

Valve Grinder.

seat may be obtained by an oscillating motion than is possible by the continuously rotating process before mentioned. This device provides a means for so doing, revolving the valve seat a little more than a revolution in one direction, and then reversing, making the process continuous.

Rotative motion of a drum A is converted into a short arc motion of the gear B, which oscillates on pin C. The pinion D meshes with B, thereby giving D a rotative motion. D is proportioned so that the arc travel of the pitch line of B is slightly greater than the circumference of D on its pitch line, which gives the latter an oscillating motion slightly in excess of a complete revolution each way.

The shaft containing pinion D is supported by two bearings, and on its other end it carries a chuck for holding the valve spindle of the job under operation.

Apparently the results are most satisfactory.

SHOP BUCKET FOR INFLAMMABLES.

The accompanying sketch shows a very useful tank for keeping inflammable substances, such as light oils, gasoline, paints, etc., where they may be readily gotten at.

It consists essentially of two light sheet iron tanks, one within the other, the outer having a cover hinged to it, which drops over the inner one. The inner vessel holds the inflammable substance, filled to any level, as desired, while the outer one is kept full of water to within a short distance of the top at all times—full enough that the

downward projecting edge of the cover is partially submerged. This forms a water seal for the inner compartment, not only protecting this latter vessel from fire, but also preventing the evaporation of the substance in a very simple manner.

In the shops of S. F. Bowser & Co., Toronto, all the dipping tanks for paint

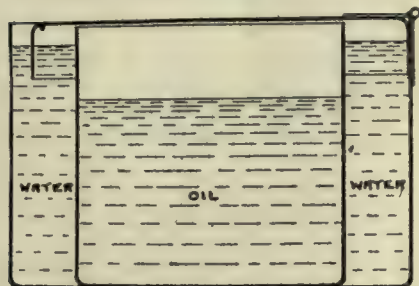

Shop Bucket for Inflammables.

are arranged in this form, as well as similar vessels for containing the gasoline used for washing oily articles, as they come from the turrets.

This firm finds it especially useful for paints, as the dip tanks are located near the enameling ovens, where fire might readily occur. In event of the latter, the simple operation of lowering the lid would suppress the conflagration without any attendant danger.

PUNCHING MALLEABLE RINGS.

The method of producing the rivet and screw holes in malleable iron manhole rings is somewhat different at S. F. Bowser & Co., Toronto, than it is elsewhere.

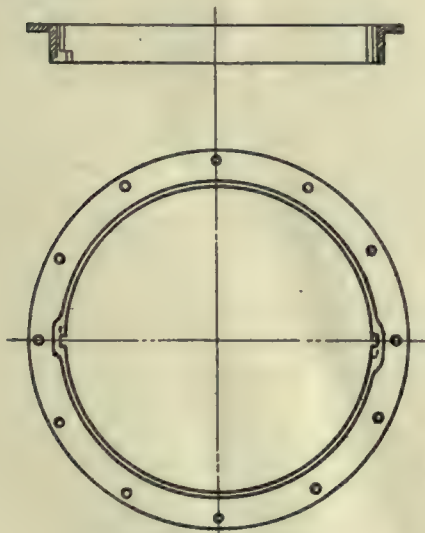

Fig. 1.—Manhole Ring.

One of their typical manhole rings for oil tanks, is shown in Fig. 1. As it is malleable iron, the usual procedure would be to drill the holes, no doubt, using a drilling jig for the purpose, the number to be produced warranting the latter.

Not so in this plant, where the holes are produced in a punch press, very satisfactory results being obtained, judging from the finished holes, which are as smooth and free from burr as if drilled.

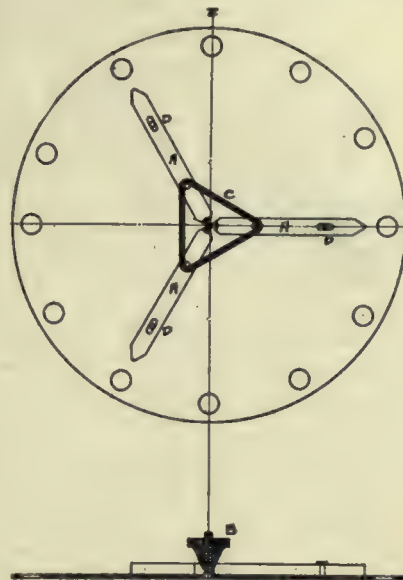

Fig. 2.—Manhole Ring Jig.

A unique punching jig, Fig. 2, enters into the process, in conjunction with the special form of die, Fig. 3, the combination making very rapid production possible.

The ring is laid on the jig (which are of different sizes to suit the different rings) and clamped there by the three projecting arms, A.A.A., which are forced out by a tapered nut, B, on a stud fastened to the body of the jig. This nut fits into correspondingly-shaped cuts in the arms. These three arms automatically centre the work in the jig. When the tapered nut is loosened, the arms are drawn back rapidly by a coiled

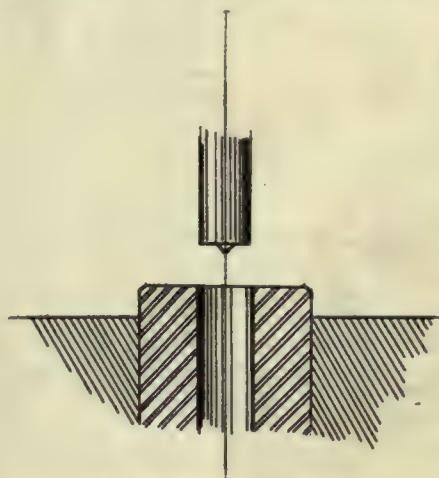

Fig. 3.—Punch and Die.

spring, C, around pins in the three arms, guided by pins in slots, D,D,D.

When punching, the jig is on the under side, the holes in the jig being placed

in succession over the die, which is made slightly tapering to receive them, thereby centring each hole instantly for punching. This allows of very rapid production.

The same principle of jig and die is utilized in all punching work in these shops, for most of their work is standard, making the initial cost of such a jig a profitable investment. Some of these jigs run as large as five feet in diameter, the same die being used throughout, unless the size of the hole requires changing.

DRILL STAND.

At the John Inglis Co., Toronto, a drill stand is used in connection with an air drill and finds many varied uses. By means of it, holes can be drilled or reamed. A hand ratchet drill could also be used.

This simple but useful tool consists of a post firmly fixed in a flat piece of iron in which is a slot, so that it may be easily bolted in a convenient position for the work to be done.

The top arm is a flat piece, tapered at one end and double at the back, a

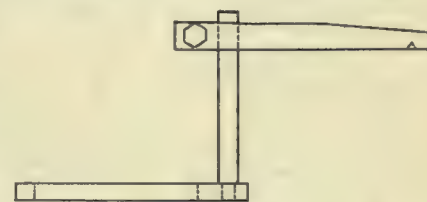

Drill Stand.

second flat piece having been welded on to the first. The two fit around the upright post, the horizontal bar being held in position by a bolt. A small drilled hole at the outer end allows the top of the drill to sit firmly in position. The idea in having the cross bar slide up and down the post is to adjust the tool to the work quickly. It can therefore be used for work outside the screw on the air drill or the hand ratchet.

DRAFTSMAN'S POINT.

A draftsman often finds it necessary to mark points on the paper by a pin point. The accompanying illustration shows a simple draftsman's needle point for such work. A piece of stock is



Draftsman's Point.

whittled to convenient size and a needle pushed into it, the head of the needle being pushed into the stick.

This instrument can also be used to hold drawings on the drawing board when it is not necessary to use the T-square.

BABBITTING BEARINGS.

In a Toronto machine shop the method shown in the accompanying illustration for babbitting bearings has been adopted. Two little screws are used on which to rest the shaft. The



Babbitting Bearing.

holes are drilled at an angle of 90 degrees and very close to the outside of the bearing. The shafts are aligned by raising or lowering the screws. After pouring the babbit, the screws can be removed.

DRILLING CONNECTING ROD ENDS.

A pair of special clamps for holding and aligning gas engine connecting-

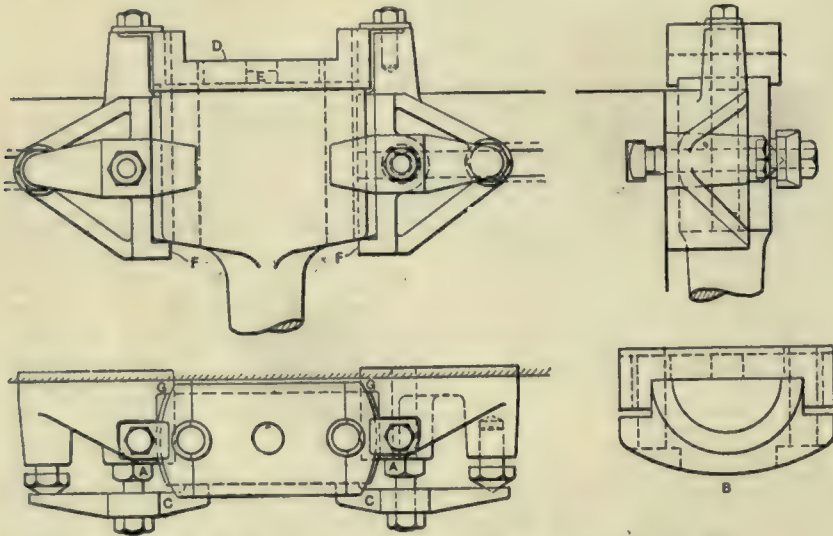

Special Clamps and Jig for Drilling Connecting Rod Ends.

rods while the bolt holes are being drilled, and also the jig used for locating the drill are shown in the accompanying illustration. The end of the finished rod is held between the two clamps or special angle-plates. These clamps each have a rib or tongue on the back that fits a T-slot of the machine table. In this way they are set parallel to each other and in line with the drill spindle. By tightening the nuts A, these plates are fastened to the machine. The same bolts that hold the plates to the table are also used for tightening the clamps C. One end of these clamps rests on adjustable screws

with conical casehardened heads, which may be set to different heights to correspond with work of different thicknesses. On the top of each angle-plate there is a boss in which is tapped a small stud that is used in conjunction with the clamps shown to hold the drill jig D. This jig is used for drilling the outer half of the bearing brass, as well as the connecting-rod bolt holes. A channel is planed in one side of the jig, so that it is a snug fit over the end of the rod, while on the other side it is planned out at right angles to the first side as shown. The projections thus formed on either end, fit over the bearing brass as shown at B. The jig is further located for drilling the bolt holes in the rod end, by a central hole which fits the projection E on the rod.

After the connecting-rod is turned and planed, and is ready to be drilled, it is placed between the two plates which are movable sideways. The work rests on the lugs F and the plates are fastened, as before stated, by tightening nuts A. The rod is then clamped against the faces G. The drill jig is then placed on the end of the rod and lightly clamped against it. The drilling

is then done by the usual method. When drilling the holes in the outer half of the crankpin brass, with the jig in the position shown at B, the tool steel drill is cutting on one side only, through part of the hole.—Machinery.

Correspondence

EJECTOR MANUFACTURER.

Can you give me the name of the maker of ejectors to draw water with compressed air?—Ontario Subscriber.

The Penberthy Injector Co., Windsor,

manufacture such an ejector. They will be pleased to send catalogue if you write them.—Editor.

CABLE TRANSMISSION.

I wish to transmit power 70 ft. to a sawmill, will you give me the name of the company who can instal a cable system to transmit about twenty-five horse power?—Quebec Subscriber.

The Dodge Mfg. Co., Toronto and Montreal, and Canadian Fairbanks, Montreal and Toronto, will give you full particulars and equipment.—Editor.

DESIGN OF BEVEL GEARS.

In the article on "The Design of Bevel Gears," by G. D. Mills, on page 38 of the April issue of Canadian Machinery, the formulae should read Cot. L (Cotangent L), instead of Co.+L, as printed.

WAX PATTERNS.

Kindly give us a formula for wax mixture in making wax patterns.—Ontario Mfgr.

For making wax patterns some use pure beeswax—2 parts of wax to one of rosin; others, ozokerite with a small quantity of Venice turpentine or kerosene to prevent it from shrinking. The two above mixed together also gives good work.

NEWALL TOLERANCE STANDARD.

The Newall Engineering Co., Blackhorse Lane, Walthamstow, London E., England, have issued a chart for gratis distribution, giving tables of allowances for the various classes of fits in millimeters. The Newall System is based on "hole basis" by which all holes are produced as near standard size as commercially possible.

Class F is a force fit and will produce shafts that will require hydraulic pressure or heating to force them into holes. Class D (driving fits) will produce shafts that will require driving in; Class P (push fits) shafts that can be pushed in but are not free enough to rotate; Class X, Y and Z are running fits. Class X is suitable for engine and other work where easy fits are required; Class Y is suitable for high speeds and good average machine work; and Z is suitable for fine tool work.

Classes A and B are tolerances in standard holes. The tolerances in each case is the difference between the high and low limits, and represents the work-levers shown and can be accomplished

CANADIAN MACHINERY

AND MANUFACTURING NEWS

A monthly newspaper devoted to machinery and manufacturing interests mechanical and electrical trades, the foundry, technical progress, construction and improvement, and to all users of power developed from steam, gas, electricity, compressed air and water in Canada.

The MacLean Publishing Co., Limited

JOHN BAYNE MACLEAN, President **W. L. EDMONDS, Vice-President**
H. V. TYRRELL, Toronto **Business Manager**
G. C. KEITH, M.E., B.Sc., Toronto **Managing Editor**
F. C. D. WILKES, B.Sc., Montreal **Associate Editor**

OFFICES:

CANADA	UNITED STATES
MONTREAL - Rooms 701-702 Eastern Townships Bank Bldg	NEW YORK - R. B. Huestis
TORONTO - 111-127 University St. Phone Main 7384	1109-1111 Lawyers' Title, Insurance and Trust Building
WINNIPEG , 511 Union Bank Building Phone 3736	Phone, 1111 Cortlandt
BRITISH COLUMBIA - Vancouver F. R. Munro	FRANCE
Room 21, Hartney Chambers	PARIS - John F. Jones & Co., 31bis, Faubourg Montmartre, Paris, France
GREAT BRITAIN	SWITZERLAND
LONDON - 88 Fleet Street, E.C. Phone Central 12960 E. J. Dodd	ZURICH - Louis Woll Orell Fussli & Co.

Cable Address:

Macpubco, Toronto. Atabek, London, Eng.

SUBSCRIPTION RATE.

Canada, United States, \$1.00, Great Britain, Australia and other colonies 4s. 6d., per year; other countries, \$1.50. Advertising rates on request.

Subscribers who are not receiving their paper regularly will confer a favor on us by letting us know. We should be notified at once of any change in address, giving both old and new.

Vol. VI.

July, 1910

No. 7

DEMONSTRATING MACHINE TOOLS.

Robert Pierpont, works manager of the Olds Motor Works, said in the course of his paper before the National Machine Tool Builders' Association at Rochester, N.Y., in which he argued for a simplification of machine tool design:

A number of the tool builders, when they sell a machine or a number of them, send out a demonstrator or a man to instruct the manufacturer how to use it properly to obtain the best results. Some of you keep men on the road all the time, going from place to place to see that your machines are used as they should be. The point I wish to make is this: Are any of you sending your designers around to see what they can learn from the actual conditions existing in the automobile factories? If not, why not? Let them visit and talk with the heads of departments, the general foremen and superintendents of a number of the automobile factories where your machine tools are used. You will then find whether your machine is the best for the work that you can make it or not; also whether you could not make it cheaper and have it answer the purpose just as well. If you will do this you will find out more about what is required than you ever can by getting some one like myself to tell you how little he knows about machine tools.

The statement is full of suggestion. By demonstrating the machine tool, the builder of same, interests the purchaser in the machine and makes a satisfied customer. On

the other hand, the machinery builder gets many good ideas from the demonstrators. Co-operation between the builders and users of machine tools would be of mutual benefit, therefore. Each would profit by the assistance of the other. The "getting together" would no doubt greatly assist in the development of more efficient and economical manufacturing equipment.

WILL PRICES ADVANCE?

Many in the manufacturing trades are viewing with anxiety the passing of the various iron and steel industries into one or two large corporations working together to control the market. In the past there has been difficulty in securing prompt delivery of goods ordered, and already there are rumors of advances in wrought and bar iron, bolts, nuts, etc.

The general understanding is that mergers aim to increase profits by effecting savings in production and distribution rather than by price advancements, but when companies which have not been paying dividends are turned over to corporations capitalized at several times the capitalization of the various companies included, it is apparent that some special effort will require to be made if the shareholders in the larger corporations are to get any return on their investment.

PROTECT THE MACHINERY.

The list of accidents continues to grow in spite of campaigns to secure the protection of machinery. From Deseronto, Collingwood, Vancouver, and other points come reports of industrial accidents. The companies may not always be responsible, but in any case, the number of accidents could, no doubt, be greatly lessened by protecting the belts and machinery.

Another thing that would assist in the lessening of the number of accidents would be to have one man trained to look after belts, an engineer or mechanic who will exercise care in the performance of his duties. In many industries it is the custom to allow Tom, Dick or Harry fix the belts near his machine, and if he is not careful, or does not understand his work there is a chance of an accident.

In the month of May, 1910, there were 133 deaths through accidents among employes in Canadian industries. In addition 243 individual work people suffered serious injuries.

CANADA'S LARGE TRADE.

Final figures of revenue and expenditure for the last fiscal year, ending March 31, made public by the Department of Finance, show a record surplus of \$22,092,185 in revenue over all ordinary expenditure. This exceeds by over two and one-half millions the previous high record of 1907-08, and is five millions better than the estimate given by the Finance Minister in his Budget speech of December last. The total revenue was \$101,501,034, an increase of \$16,500,000 over the preceding year. The total expenditure on consolidated fund account was \$79,409,849, or \$4,500,000 less than 1908-09. On capital account last year there was spent \$34,114,994, including \$19,968,064 on the construction of the National Transcontinental Railway. Out of the revenue Canada paid last year every item of ordinary and capital expenditure, exclusive of the National Transcontinental, and had over \$8,500,000 still left towards the construction of the railway. Probably no other country in the world can show anything like

so satisfactory a financial statement for the year, and with the revenue for the current year increasing at the rate of \$1,500,000 a month, indications point to an even greater surplus for the twelve months.

The net debt of the Dominion at the end of the fiscal year was \$336,266,348, an increase during the year of \$12,336, due, as has been noted to three-fifths of the year's expenditure on the National Transcontinental Railway.

In his Budget speech Hon. Mr. Fielding conservatively estimated the total revenue at \$97,500,000. The actual revenue went \$4,500,000 beyond his estimate. He estimated the total expenditure on consolidated fund account at \$81,000,000. It fell short of this by \$500,000.

The principal items of revenue were as follows:—Customs, \$60,156,133; excise, \$15,253,352; post office, \$7,958,547; public works, including railways, \$10,114,990; miscellaneous, \$8,018,009.

The principal items of expenditure on capital account were as follows:—Public works, railways, and canals, \$27,571,225; militia, \$1,299,970; railway subsidies, \$2,048,097; bounties, \$2,411,095.

The figures of Canadian trade for May show a record advance over May last year. The total trade for the month was \$59,187,972, an increase of \$14,276,236, or over thirty per cent., as compared with May of last year.

Imports totalled \$38,821,963, an increase of over ten and one-half millions, and the largest increase on record for any one month.

Exports of domestic products totalled \$18,347,432, an increase of \$2,537,225. Exports of foreign products totalled \$2,018,577, an increase of over one million.

For the first two months of the current fiscal year (April and May), the total trade of Canada was \$105,171,866, an increase of twenty-five and a quarter millions as compared with the corresponding months of 1909.

At the present rate of increase Canada's total trade will within two years reach the billion dollar mark. For the current year indications point to a total trade of over \$800,000,000.

The customs revenue for May was \$5,818,490, an increase of \$1,576,170, as compared with the corresponding month of last year.

The statement of the Canadian chartered banks for May reflects the continued expansion of business in the Dominion. For the first time the liabilities of the banks have passed the billion mark; the assets reached that stage about 18 months ago.

The chief comparisons of the month as compared with April, are as follows, the first figures being those for April and the second for May:—

Notes in circulation	\$ 78,776,228	\$ 77,194,344
Deposits on demand	246,746,180	256,651,635
Deposits after notice	521,427,172	524,680,979
Total liabilities	993,105,845	1,015,631,890
Call loans on stocks	59,621,328	58,159,050
Current loans in Canada	638,347,238	643,246,518
Total assets	1,182,850,969	1,205,001,218

CANADA'S PATENT RELATION.

Elsewhere in this issue is an article dealing with the patent relations of Canada to the rest of the world, in as far as the International Convention for the protection of industrial properties is concerned. As pointed out in that article it does appear very strange that Canada should be one of the very few powers who are not signatories of

that convention. Doubtless there must be many advantages therein, or the nations interested would not be increasing to such an extent as to be leaving Canada almost isolated. From enquiries among patent solicitors, Canada does not appear to be taken very seriously as a patent country, which is exemplified by the fact that Canada never has any patents cited against her, while Great Britain, Germany, France, the United States and other principal powers have, indicating that Canadian patent records are seldom, if ever, consulted by these foreign patent offices when verifying the validity of an application. It is to be hoped that this matter will be taken up by manufacturers in general, and all interested parties so that the subject may be thrashed out. Canadian Machinery would appreciate receiving readers' views on this subject.

FALL OF WATER TANKS.

The fall of the water tank on the Herald Building, Montreal, recalls other similar accidents though fortunately not attended with such disastrous results. In the business and manufacturing quarters of our cities and towns are structures on which are perched tanks containing great quantities of water. In some cases the tanks are on separate steel supports, and in other cases they are erected above factories and business houses in which are hundreds of employes.

Inspectors in Montreal, Ottawa and Toronto are now looking carefully into the construction of tanks and supports. Their example should be followed by every city and town where tanks have been installed. In Toronto the supports must be of four times the strength really required. Sometime ago a tank fell in Toronto, but it was erected without a permit. A tank of water weighs from 50 to 250 tons, and in it is an enormous possibility of peril.

There are several things in connection with the erection and maintenance of a tank to lessen the possibility of falling. When a separate tower is erected it should be built on a concrete foundation over rock if possible, and a six to ten-foot base on "hard pan" where this is not possible.

Hoops on wooden tanks should receive special attention and all rust should be removed before painting. Particular attention should be given to tanks placed on roofs and covered with corrugated iron. The hoops corrode very rapidly between the corrugated iron and the staves, and the hoops may be found almost corroded through a few years after erection.

If a tank is left empty, the sun and rain will cause the staves to warp so that it cannot again be made water tight.

Tanks cannot last forever and careful inspection should be made each week. The life of a tank is from 12 to 30 years. They average about 15 years, but they must be painted often and kept filled with water.

A large factor of safety should be allowed for supports. If erected on brick walls, great care should be taken in this connection. A purchaser of a tank should not cut down the designer and builder of a tank to the last cent. It is very poor economy. When the tank has been installed, it is the duty of the owner to have all iron work, bolts, etc., carefully inspected at regular intervals. In this way the number of failures of water tanks and supports will be lessened.

DEVELOPMENTS IN MACHINERY

New Machinery for Machine Shop, Foundry, Pattern Shop, Planing Mill; New Engines, Boilers, Electrical Machinery, Transmission Devices.

ECLIPSE BOLT-HEATING FORGE.

The Monarch Engineering & Mfg. Co., 1200 American Bldg., Baltimore, Md., have placed a new bolt-heating furnace on the market, operated with oil or gas and air. The forge is of use for bolt, boiler, railroad, bridge, structural and general shop work.

The heat can be regulated in this furnace. There is also a new patented keyed fire brick. There is an arrangement of special bricks within the lower chill to prevent them from becoming disarranged. The top of the arch is so devised as to act as a retainer for the brick, forming the arch over the heating space, and at the same time acts as a protector for the operator. This top is also adjustable, making it possible to obtain any desired length of heat up to capacity of furnace. Being adjustable in either direction it is possible to heat any diameter iron desired, by simply raising or lowering this top to height required for entrance of blanks and adjusting pin to keep same in required position. Also that this top being water-chilled prolongs the life of brick used in same. The makers claim that any length of heat desired can be obtained and that blanks as short as $\frac{1}{2}$ -inch in length can be heated and withdrawn as rapidly as those of a longer length; this being made possible by the leveled arrangement of this top.

By the device of grooves as per lower chill, the blanks can be inserted and kept apart, thus should operator through some mishap neglect to withdraw the blanks before they become over-heated they will not stick together.

MONARCH RIVET-HEATING FURNACE.

The Monarch furnace illustrated herewith is portable, and made in standard sizes. It can readily be carried around from place to place by two men. They are especially recommended for ship, bridge, boiler and general construction work, and will produce excellent results.

Where quantities of rivets are required, it is a rapid heater, bringing the same to a white heat in three minutes, under compressed air pressure of twenty pounds or higher; with a volume of fifteen cubic feet per minute; the higher the pressure, quicker the results. It can also be used in connection with the Monarch high pressure blower, which is furnished in various sizes according to number of forges in use.

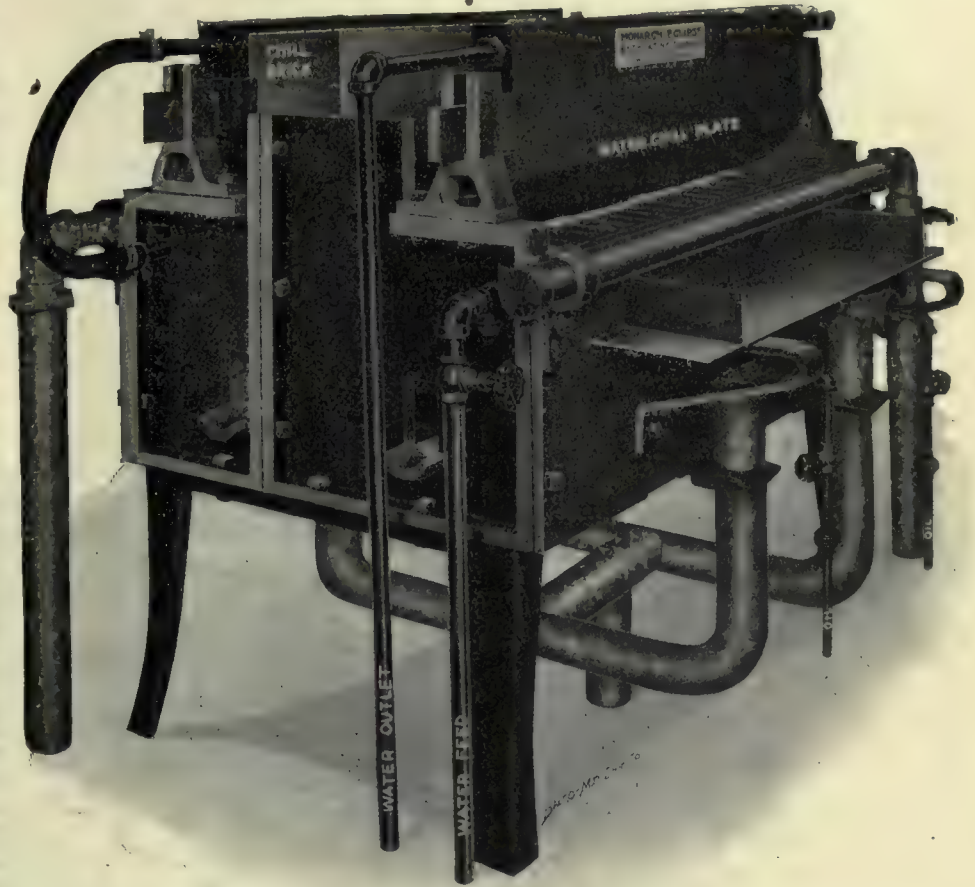

New Monarch Eclipse Bolt Heating Forge, Monarch Engineering & Mfg. Co., Baltimore Md.



New Monarch Bolt Heating Forge, Monarch Engineering & Mfg. Co., Baltimore, Md.

The furnace carries a high, soft, uniform heat, and is always under control of operator. Rivets are always in plain sight, and readily reached. It will heat up to inch and one-half in diameter, an average 500 per hour. Amount of oil consumed is from one and one-half to two gallons per hour, according to quantity of rivets heated. It can also be used for light forging, hardening, tempering, annealing and welding.

The flame is directed into combustion chamber "A" where the oil is thoroughly ignited, it then passes into the heating chamber "B" the construction of which gives the flame its rotary motion, distributing the heat uniformly throughout the whole interior.

The waste heat escapes through the opening "C" and distributes itself into the open chamber "D" where the rivets may be placed prior to their being put into heating chamber "B".

The top tile is supported on the 4 piers E. The furnace has two doors F-G, front and back. The furnace is supported on a steel cylindrical sheet, which contains the fuel oil tank I and the whole on a cast iron base. The furnace top is made of steel securely welded together with angles riveted to bottom of same so that the furnace top

of very low quantity, the burners of "Monarch" type being regulated for largest volume of air, consistent with lowest consumption of oil.

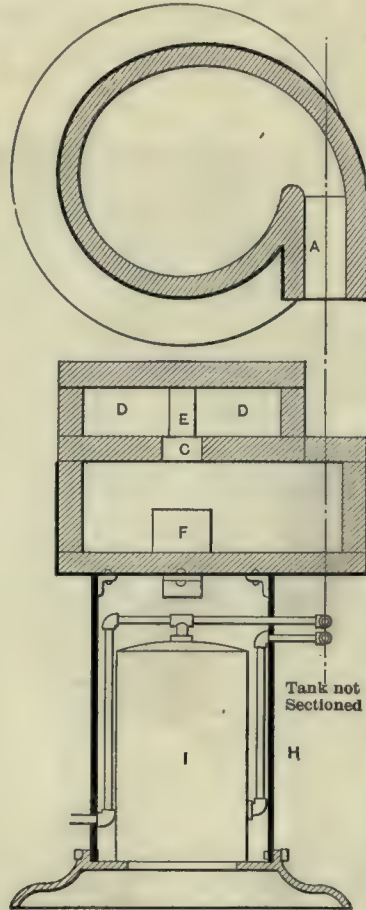

Section Monarch Rivet Furnace.

The furnace is manufactured by the Monarch Engineering & Mfg. Co., Baltimore, Md.

HEATING IRON AND STEEL FOR FORGING.

The use of oil as a fuel was not given very serious consideration until after the discovery of the large deposits of low-grade crude oil in the west and southwest sections of this country. Coal

was expensive in Beaumont, Texas; besides, there was not room to store any great quantity of it convenient for use. The derricks were so thick on Spindle Top that there was no room there for boilers, so these were arranged on the edge of the field along each side of a road, which became known as "Boiler Avenue." Oil was burned under all these boilers. The burner consisted simply of a perforated end of gas pipe with a steam jet so arranged that the oil was sprayed against a target of fire bricks in the fire-box of the boiler. All the fireman had to do was to regulate the amount of oil occasionally by means of the check valve. The heat of the oil fire is very intense, and while this rough and ready method did not secure a very even heat distribution, yet it answered the purpose and was in every way a great improvement over the best results obtainable by hand-stoking.

Great improvements have been made in oil burners since those early days. Recently tests were made on a Kirkwood oil-burning furnace, which is made by Tate, Jones & Co., engineers and manufacturers, of Pittsburg, Pa. A description of this furnace may be of interest to the readers of Canadian Machinery.

The furnace described herein is used in heating iron and steel for forging, etc., in plants where oil is not regularly used as fuel. This firm also manufactures similar furnaces for annealing, tempering and case hardening. The burner is different from any of the other oil burners on the market in that the oil and compressed air for atomizing are controlled by one lever, the proportions being determined by tests at the factory before the furnace is shipped. Once determined, this burner is so adjusted that this ratio of air to oil is fixed and is not left to the judgment of the operator. Since the proper atomization of the oil is the vital point in the successful oil burner this arrangement is of great value and prevents any troubles.

The air for forcing the oil to the burn-

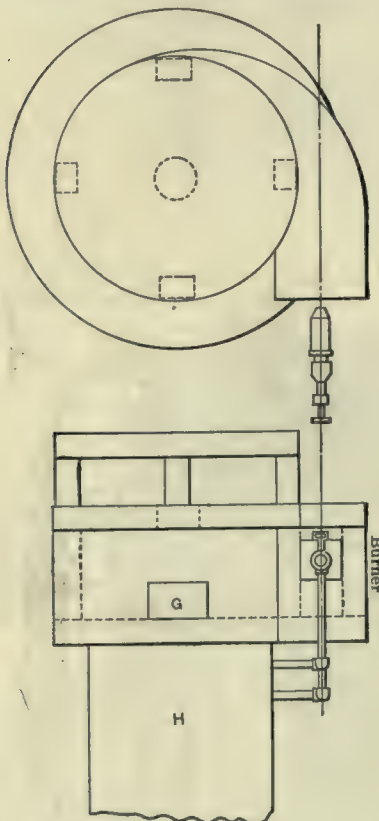

Burner of Monarch Rivet Furnace.

may be set on to sheet without being permanently attached to it. The supply for tank is fed through same pipe that feeds burner. The fuel consumption is

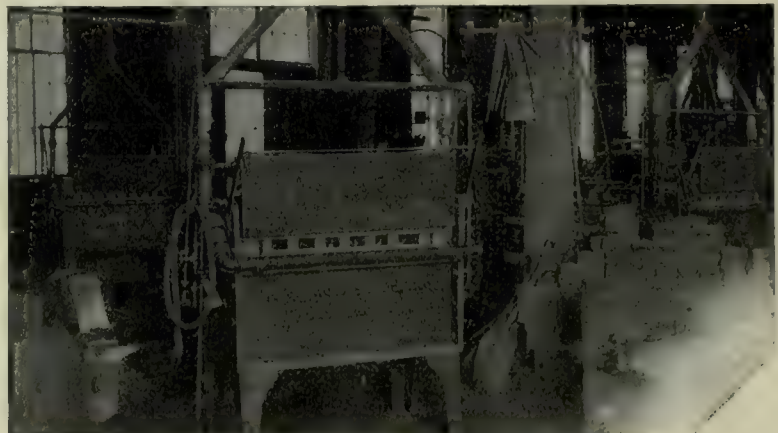

Heating Iron or Steel for Forging.

er under pressure and for atomizing and oxydizing it, is supplied by a small rotary blower, which is mounted on the floor near the furnace, and may be driven by an electric motor or other source of power.

About 60 cubic feet of air compressed to 25 pounds is used for atomizing the oil; the pressure at the burner being about 20 pounds. The portion of the air blast which furnishes the necessary oxygen for proper combustion is so regulated, by the lever just referred to, that the pressure at the burner is from two to four ounces. The regulation of this pressure varies the fire from an oxydizing flame to a strong reducing heat. This gives the operator the exact heat wanted at a moment's notice. The burner can be cleaned without disconnecting it from furnace and is nearly noiseless in its operation.

A steam jet or the regular shop compressed air supply can be used for atomizing the oil if desired. In the latter

case a reducing valve is necessary to cut down the pressure to the proper amount for atomizing. This valve is supplied with the furnace if so desired.

The burner is set up under an inclined arch of fire clay at the centre of the furnace, the inclination being from the burner downward, so that the products of combustion travel down the arch, completely encircling and filling the inside of the furnace and escaping through two vents in the upper corners on the same side as the burners. This gives equal distribution of the heat through every part of the furnace.

The furnace is lined throughout with the best quality of fire brick, carefully laid, and between the fire brick and outside metal wall a thick layer of asbestos is placed. This heat insulation saves fuel and prevents the air in the neighborhood of the furnaces from becoming unpleasantly warm.

The oil for this furnace is carried in a tank attached to the side, the tank be-

ing filled from a barrel when necessary by a small rotary hand pump. For plants having an oil fuel supply the tank is not necessary.

RADIAL DRILL.

Herewith is illustrated a new style of radial drill, which has been placed on the market by the London Machine Tool Company, Limited, Hamilton.

The features of construction in this machine are the bottom drive to the spindle, the back gears and reversing gears on the head, and square face to column. As will be noticed from the illustration, the spindle is driven on its lower end. The power is therefore applied at the nearest point to drill, and the pressure on the driving key is reduced to a minimum, making a feed drive very easy.

The back gears are placed on the head, and are of the positive automobile type, back gear being thrown in while the machine is in operation. The frictions in the reversing gear are of an extremely powerful band type, operating independently of any pressure which may be put on the reversing lever.

The feeds are four in number, of suitable range. The spindle has quick hand power movement through hand wheel and worm or power, as desired. The head is racked across the arm by means

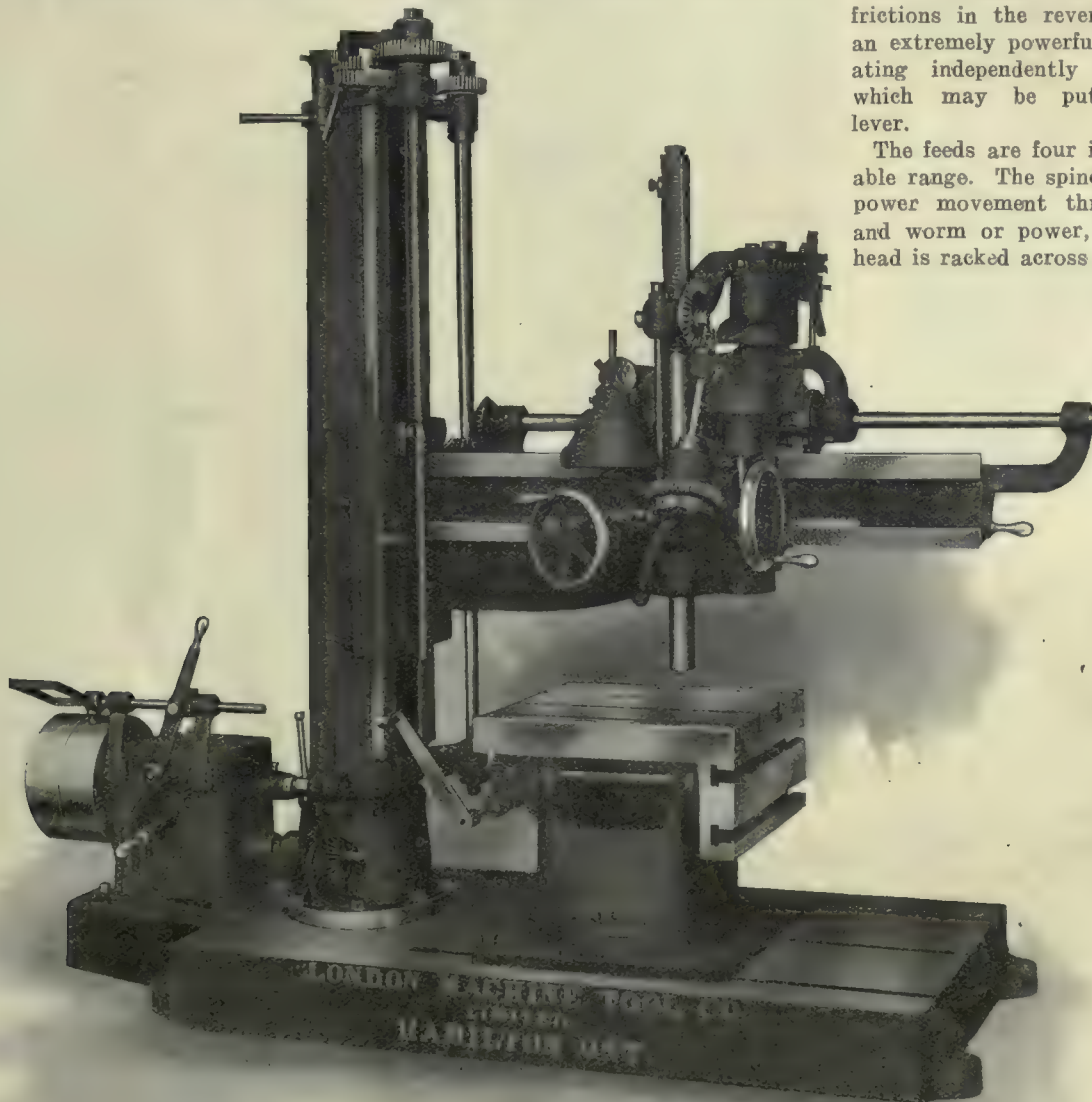

New Radial Drill, London Machine Tool Co., Hamilton.

of hand wheel conveniently located. All handles are so located as to make all operations most convenient for the operator. Outer column is provided with a square face, which insures accurate alignment. The outer column revolves in an inner column at its top and bottom surfaces, and revolves on ball bearings with suitable clamping mechanism.

On the positive gear box shown in the illustration, all gears are of steel, of positive type, making it impossible to get out of order. The machine is also furnished with cone drive, if desired.

The machine is made with plain or swivel table, swivel table being shown in illustration. This latter table makes the drill entirely universal in its operation. The success of this line of radials has prompted the London Machine Tool Co. to re-design their whole line of radial drills, using the bottom drive.

IMPROVED BEVEL PROTRACTOR.

The Improved Bevel Protractor, shown in the cut herewith, was recently put on the market by the Brown & Sharpe Mfg. Co., of Providence, and is an accurate and inexpensive tool for laying out or establishing angles. Not only is it useful to draftsmen, but it is also of great service to mechanics.

In design the tool is very simple and is very similar to the Improved Uni-

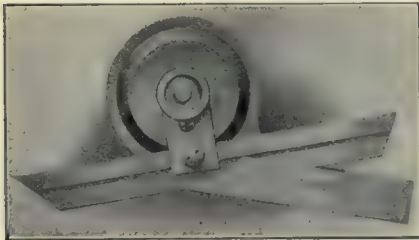

Brown & Sharpe Improved Bevel Protractor.

versal Bevel Protractor, made by the same company. The main point of difference between the two tools is the fact that there is no vernier on the Bevel Protractor and so the measurements cannot be made to such a degree of fineness.

To facilitate use of the tool one side of the protractor is flat and this allows the tool to be laid flat on the paper or work, a decided advantage that users of the protractor will appreciate.

The dial is graduated in degrees and these graduations extend over an arc of 180 deg., reading from zero to 90 deg. from each extremity of the arc. Especial care is taken with these graduations to have them accurate.

The large central stud upon which the dial of the protractor turns is hardened in order to eliminate as much wear as possible. When the protractor is set and the nut tightened it clamps the dial rigidly in position so that there is no danger of slip.

The blade of the protractor is free to move backward and forward for its entire length independently of the dial and this adapts it unusually well for work where other protractors cannot be used. It is clamped independently of the dial and is rigidly held in place.

Great care has been taken in cutting the grooves, etc., so that there is very little chance for dust to accumulate and cause inaccuracies in the measurements.

BARNES TAPPING MACHINE.

While the general design of the new Barnes all-g geared automatic reversing tapping machine is the same as the standard all-g geared drill, a single pulley is used for driving and for reversing. The friction clutch gears give reverse speed of $1\frac{3}{4}$ to 1 and these gears are on the driving end of the machine—

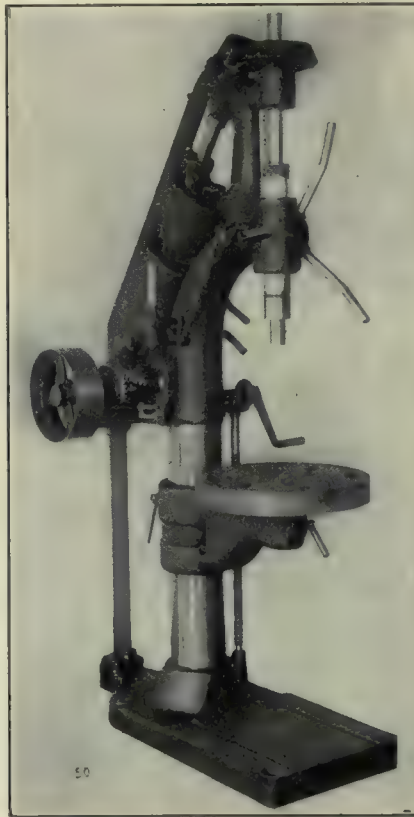

New Tapping Machine, Barnes Drill Co., Rockford, Ill.

not on the spindle—a strong point in favor of this machine.

It has automatic reversing mechanism, as shown, useful particularly for depth tapping. It can be set so that the instant tap reaches depth desired, spindle will automatically reverse, backing out at double speed. It can be set so as to trip automatically (or by hand) stopping the spindle instantly instead of reversing same.

The small hand trip lever shown is always ready for instant use if desired to reverse or stop spindle at any point in the operation. It has four direct-g geared

speeds and four back-g geared speeds, making eight changes of geared speeds available on this machine. It is built in 20-inch and 24-inch sizes. The 20-inch machine drives a $1\frac{1}{4}$ -inch U. S. standard tap 125 r.p.m. in cast iron without back gears. When back gears are in, it drives a $1\frac{1}{2}$ -inch U. S. standard tap 50 r.p.m. in cast iron. The 24-inch all-g geared drill will handle up to 2-inch U. S. standard tap.

With positive power feeds added to these machines, they can be used advantageously for both drilling and tapping. They are manufactured by the Barnes Drill Co., 602 South Main Street, Rockford, Ill.

FREE COLLEGE COURSE.

College educational work by the Canadian railways has hitherto to a large extent concerned itself with training of sons of employees, so as to fit them for future positions in the service. In this connection a circular has just been issued by Charles M. Hays, president of the Grand Trunk, announcing the terms of competition for three free scholarships at McGill. These scholarships each cover four years' tuition in the Faculty of Applied Sciences of McGill University, and are offered, subject to competitive examinations, to apprentices and other employees of the company under twenty-one years of age, and to minor sons of employees.

The competitive examinations, which will be the regular entrance matriculation examination provided for in the Annual Calendar of the University, were held at the University, Montreal, and at other centres, beginning June 13, 1910. The three candidates making the highest average and complying with the requirements of admission will be awarded the scholarships and have the option of taking a course in any department of the Faculty of Applied Science. Scholarships will be renewed from year to year, to cover a period not exceeding four years, if at the close of each session, the holders thereof are entitled, under the rules, to full standing in the next higher year.

In consideration of the free scholarships, students will be required to enter the service of the company as student apprentices, and serve during vacation period while in attendance at the University, and at the option of the company, for two years after completing the college course. Successful candidates will, before entering the University, be required to execute the company's regular form of student apprentice contract, copies of which can be obtained upon application to R. S. Logan, assistant to president, Montreal.

Large Successful Foundrymen's Convention at Detroit

Resume of Association Papers—Exhibits of Foundry Machinery Were Large and Interesting — Pittsburg is the Convention City for 1911.

The Foundrymen's Convention at Detroit marked another milestone in the successful gatherings of the allied foundry associations,—the American Foundrymen's Association, the American Brass Founders' Association, the Foundry & Manufacturers' Supply Association and the Associated Foundry Foremen. The meetings for the reading of papers and their discussion, and the transaction of business, were held in the Michigan State Building at the State Fair Grounds. The exhibit of foundry equipment and supplies filled the Administration, Main and Horticultural Buildings, while the overflow was housed in a large tent.

A feature that occasioned many favorable remarks was the fact that Canadians in larger numbers than ever took the opportunity to visit the exhibit, see machinery in operation and obtain literature on the latest and best equipment for foundries, whether brass, grey iron or steel. A partial list of the Canadians present is given. As a large number did not register, however, it was impossible to obtain a complete list.

Monday, June 6.

The formal opening of the fifteenth annual convention took place at Hotel Pontchartrain, Monday night, the occasion being marked by a banquet tendered to the officers of the A.F.A., the A.B.F.A., the F. & M.S.A., the A.F.F. and representatives of the technical press.

Dr. Frank T. F. Stevenson made an address of welcome, followed by Arthur S. Waterfall, the president of the A.F.A. Mr. Waterfall is general superintendent of the Russel Wheel & Foundry Co. Joseph T. Speer, Pittsburg, spoke on the national organization. Dr. Richard Moldenke spoke on the foundrymen's questions.

The A.B.F.A. was represented by their vice-president N. K. Patch, of the Lumen Bearing Co., Toronto. Other speakers were Eugene Smith, Chicago, president of the A.F.F.; J. J. Wilson, vice-president of the Detroit foundrymen's association; L. L. Anthes, of the Anthes Foundry, Toronto, and F. B. Stevens, Detroit.

Tuesday, June 7.

The first business session opened at ten o'clock in the Michigan State Building, Arthur T. Waterfall occupying the chair. This was a joint session of the four associations. The visitors to Detroit were welcomed by Mayor Bretmeyer and President Larned, of the Board of Commerce.



JOSEPH T. SPEER, PITTSBURG,
President A. F. A.

The welcome was followed by the presidential addresses of A. T. Waterfall, of the A.F.A. and Wm. R. Webster, of the A.B.F.A., W. M. Corse, secretary-treasurer of the A.B.F.A. and Dr. R. Moldenke, of the A.F.A. In his address Mr. Waterfall gave the membership of the association as 753, but intimated it would probably reach 850 before the close of the convention.

Secretary Corse, of the A.B.F.A., hit a popular chord when, in his report, he recommended that miners, chemists and foundrymen standardize their stock terms, the present terminology for the same article in the various trades causing great confusion.

MAJOR JOSEPH T. SPEER.

Major Joseph T. Speer, the president of the American Foundrymen's Association, is the head of the Pittsburg Valve Foundry and Construction Co. This company is an amalgamation in 1899 of Atwood & McCaffery; Shook, Anderson Mfg. Co.; Pittsburg Valve and Machine Co.; pipe fitting department of Wilson & Snyder, and the foundry department of Alexander Speer & Sons. Major Speer served his apprenticeship as a pattern maker with his father, Alexander Speer. Afterwards he devoted himself to the foundry end of the business. He became manager of Alexander Speer & Sons in 1897, and in 1901 succeeded to the presidency of the Pittsburg Valve Foundry & Construction Co., which position he now occupies.

The session closed with a talk by Steelman Stevenson, Detroit, on acetylene-oxygen repairs in the foundry. In connection with this he gave an exhibition of the art of cutting and welding, etc., practically applied.

Fluxes.

In the afternoon separate sessions were held. The A.B.F.A. met at 2 o'clock, the session opening with a paper on "Fluxes as applied to the Brass Foundry," by Erwin S. Sperry, Bridgeport, Conn. Fluxes, he said, must be used with discretion, and different ones are suitable for different metals and different alloys.

For aluminum, chloride of zinc has proved a very efficient flux. This is due to a reaction wherein a chloride of aluminum is formed and free metallic zinc alloys with the aluminum. The dross becomes fine and granular and is readily skimmed off.

For nickel, a flux consisting of three parts of lime and one part of fluor spar is used. Fluor spar alone becomes very fluid when melted and rapidly attacks a crucible. The lime used in connection with the fluor spar increases the melting point of the flux so that the crucible is not readily attacked.

For copper practically every known chemical has been tried as a flux. The selection of the proper flux depends upon the alloy to be made. Sound copper castings may be made with a flux of potassium ferro-cyanide, but the various dioxidizers, such as silicon copper, magnesium, phosphorus, etc., produce equally good and better results. Common salt is very efficient used as a flux for melting copper for producing brass or bronze. It reduces any copper oxide that may be formed during the melting.

As a flux for brass common salt is very efficacious. It is the only flux used for brass for rolling purposes.

For German silver, equally good results are obtained in the manufacture of this alloy with or without the use of a flux. Sodium nitrate with black oxide of manganese constitutes a flux used by one of the largest manufacturers of this product. The use of metallic manganese alone has also shown excellent results.

For washings, grindings, etc., a flux must be used to reclaim the metallic content. Plaster of Paris is very good for use in melting brass, bronze, or composition washings. It is cheap, has no action on the crucible, it melts readily and forms a thin slag.

A covering of charcoal should be used in melting all metals enumerated above,

as it supplies a reducing atmosphere and prevents oxidation.

Charles R. Stevenson, of Miller, Franklin & Stevenson, Business Economists, New York, followed with a paper on "Brass Foundry Costs and Statistics." He pointed out the advantage of accurate scientific methods over the "rule of thumb" way of doing business. A cost system was outlined and will appear in full in an early issue.

In the afternoon session of the A. F. A., Benj. D. Fuller, Cleveland, read a paper on "Foundry Efficiency." The questions considered were excess of weight on castings due to careless ramming, weak flasks, weak boards, loss in machinery through jigs not fitting the larger castings, etc. Molders can be kept tab upon by having a daily record showing percentage of good castings by weight. By a card giving this information a foreman can tell a man's comparative value.

Personal Equation in Accidents.

The second paper was on "Personal Equations in Accidents," by Thos. D. West, Cleveland. In his paper Mr. West states that from his experience as an employe and employer and his investigations along the line of accidents, their cause and remedies, he is certain that any unbiased and thorough investigations will show that the great majority of accidents is the result of carelessness chargeable directly to the individual, his lack of obedience to in-

dents are concerned, is often applicable to all others.

To advance a doctrine that the majority of accidents in a trade are incident to it, and neither the employe or employer is at fault, is a step likely to



N. K. B. PATCH, TORONTO.

President, A.B.F.A.

have serious results, for it takes away the sense of personal responsibility from the operative, and makes him heedless regarding the effect of his actions upon the safety of others.

The employer should help to prevent accidents by supplying safety devices. Prevention of accidents by the removal of the factors that tend to cause them should be the watchword. An honest effort by both employe and employer to remedy individual faults, the doing of which will cut down 80 p.c. of the accidents in the shops.

Mr. West's paper was followed by an illustrated talk on oxy-acetylene welding and cutting by Henry Cane, Springfield. Among the illustrations shown was one where cylinders were welded together making a six-cylinder for an automobile.

Evening Smoker.

Tuesday evening a smoker was given by the Detroit Foundrymen's Association to the visiting members of the allied associations in the Light Guard Armory. A most enjoyable time was spent, a feature of the evening being the presentation to each visitor of a stein suitably inscribed.

Wednesday, June 8.

An address was given before the A. B. F. A. on Brass Foundry Practice, by Jesse L. Jones, Pittsburg, which was followed by a paper by J. W. Richards, South Bethlehem, on "Electric Power Required to Melt Brass, Bronze, etc." Mr. Richards pointed out that in deal-

ing with metals of a low melting point it was cheaper to use coke or oil, but that in handling metals of a high melting point electricity could be used to advantage as an adjunct to coke or oil. In this connection he described the process used at a furnace in South Bethlehem for melting steel. He said that coke was used until the mass was partly melted and then electrodes were lowered and the current applied to the metal until the required degree of heat was obtained.

A report of the committee on "Chemical Standards for Iron Castings," was given by Dr. J. J. Porter. A collection of analyses of iron castings was presented in tabulated form. The information giving the composition of iron for various castings. This was followed by a paper on "Physics of Cast Iron," by H. M. Lane, Cleveland.

Visiting Plants.

Much time was spent visiting Detroit's industries. Every manufacturer threw open the doors of his plant and a visiting bureau furnished credentials and guides so that as many plants as possible might be visited.

Wednesday afternoon the visitors took a trip down the river on the steamer Columbia. On the down trip a number of the excursionists stopped at the Semet-Solvay Coke Oven Plant, and a number at the Detroit Iron & Steel Co. to inspect the blast furnace. The remainder visited the Livingston Chan-



DR. RICHARD MOLDENKEL.

Secretary American Foundrymen's Association.

structions, error in judgment and neglect of duty. An authority on railroad accidents, James O'Fagan, says that 85 p.c. of the fatalities that occur on railroads can be directly traced to the negligence of employes. What holds good in one industry, so far as acci-



W. M. CORSE, BUFFALO.

Secretary A.B.F.A.

nel and inspected the government work. In the evening there was a second excursion, this time on Lake St. Clair.

Thursday, June 9.

At the Thursday morning session of the A.B.F.A., Dr. F. T. F. Stephenson



National Core Oil Co., Buffalo, N. Y.



Robeson Process Co., Au Sable Forks, N. Y.



Brown Specialty Machinery Co., Chicago.
Buckeye Products Co., Cincinnati, O.



Henry E. Pridmore, Chicago, Ill.



Northern Engineering Wks., Detroit, Mich.



S. Obermayer Co., Cincinnati, Ohio.

read an interesting article on the value of the association to its members in which he pointed out that a member does not perform his full duty by simply joining the association. "We have fine examples of those who are doing their duty," he said, "in the men who have devoted their lives to the brass industry and who take the time to give us the benefit of their knowledge. We owe them a debt and it can be best paid by contributing the value of our knowledge and experience to the rest."

Dr. J. J. Porter, Cincinnati, gave a talk on "Co-operative Courses in Metallurgy."

At the morning session of the A. F. A. Wilfred Lewis read a paper on "The Shockless Jarring Machine," which brought forth much discussion. A full description of the shockless jarring machine was given in the February issue. Other papers were "Rejected Castings in Steel Foundries," by S. D. I. Emerson, New York; "Reward—Premium—or Bonus," by W. J. Power, New York; "Report of Committee on Industrial Education," by P. Kreuzpointer, Altoona, Pa.; "Foundry Transportation Methods," by David Gaehr, and "Overhead Transportation in Foundry," by A. W. Moyer.

In his paper Mr. Emerson pointed out that efficiency was becoming to mean the elimination of waste. He maintained that records should be kept



WILFRED LEWIS.

Tabor Mfg. Co., Philadelphia, Vice-Pres., F. & M. S. A.

and tabulated as to cause, location, number of castings, as to each molder or floor gang, with percentage of loss for each working day, or shift and statements made to these responsible for the foundry work within a few hours after the pour, if possible before

starting the next day's work. By getting at the cause through a good system it is possible to reduce the losses.

In the paper on "Reward—Premium—or Bonus," Mr. Power stated that the practical results of a co-operative effort between employer and employe, the



GEORGE RAYNOR.

Carborundum Co., Niagara Falls, N. Y., President F. & M. S. Association.

former paving the road well for the latter, should be at least a net gain in cost to the former of 28 p.c., and an increment in earnings of 20 p.c. to the latter.

Thursday Afternoon.

"Modern Foundry Practice" was a paper presented at the A. B. F. A. session by Chas. T. Boogg, Mansfield. This was an interesting article which brings out the principles underlying all progress and calls attention to those principles that are operating in the brass foundry to-day, as a means to better methods and better quality.

H. M. Lane, Cleveland gave some interesting facts in connection with a series of experiments to determine the use of magnesium in deoxidizing aluminum alloys. Mr. Lane's paper on the various types of electric furnace was also well received.

Hugh McPhee then gave a paper on a new method for mounting patterns of uneven parting for use on molding machines in which the inventor claims combination of small labor in pattern making, and cheapness in using patterns not adaptable to ordinary match plate work. The method consists in making master pattern, and from this enough white metal patterns to fill flask. This completes the work of the pattern maker. Molds are then rammed up, patterns drawn, and metal poured into each impression separately flush

with the parting line, in both cope and nowel. These patterns are then mounted on iron frames which fit flasks by means of a composition. This method of mounting is also adaptable to bench work.

C. P. Karr then read a paper on "Analysis of Lead in Alloys." The article discusses the various methods that have been successfully used in the assay of lead in non-ferrous alloys. The subject is classified according to the various methods now in vogue. It refers to the gravimetric method in which lead is precipitated from its nitrate solutions by sulphuric acid and also by treatment with a molybdate solution. Comparisons are made of these two methods.

A. B. F. A. Officers.

At this session was held the annual election of officers which resulted as follows:

President, N. K. B. Patch, Toronto; Secretary-treasurer, W. M. Corse, Buffalo; Vice-Presidents, Thos. Evans, Philadelphia; J. C. Sharpe, Chattanooga; W. L. Abate, New York; W. H. Carpenter, Bristol; Richard Augenbraun, Stamford; L. M. Olson, Mansfield; John Wolf, Chicago; J. N. Gamble, Kewanee, Ill.; and Richard R. Mitchell, Montreal.

Foundry Foremen Officers.

The following officers were elected for the coming year: President, Robert B.



C. E. HOYT, CHICAGO.

Secretary F. & M. S. Assoc.

Thomas, foreman of Buffalo Pitts Co., Buffalo.

Mr. Hoyt was elected secretary-treasurer until a new executive board shall select a secretary. There will be a new method of control consisting of an executive board appointed by the

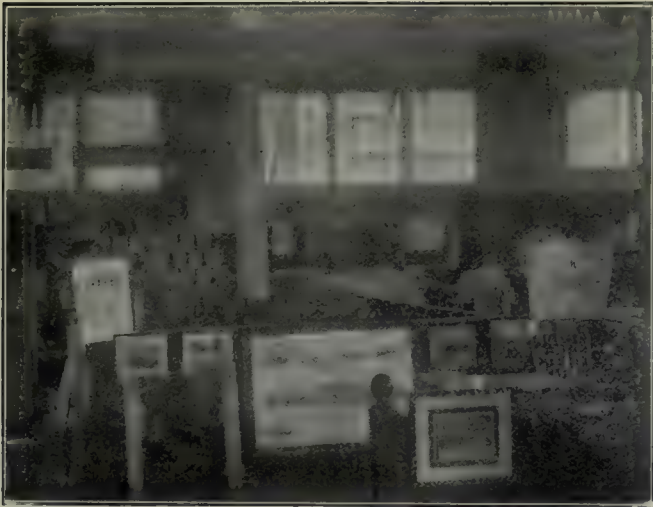

Browning Engineering Wks., Cleveland, O.



The Adams Co., Dubuque, Iowa.



Joseph Dixon Crucible Co., Jersey City, N. J.



Osborn Mfg. Co., Cleveland, O.



Frederic B. Stevens, Detroit, Mich.



Calumet Engineering Wks., Harvey, Ill.

president, to perform the work of the Foundry Foremen's Association. The executive will act as vice-presidents this year.

A.F.A. Thursday Afternoon.

A number of papers were read, Dr. Richard Moldenke giving suggested specifications for foundry coke. Dr. Moldenke proposed that coke be bought according to its property to melt iron and specifications were given to govern buying, reference being made to sampling, base analysis, moisture, volatile matter, fixed carbon, ash, sulphur, and shatter test.

Thursday Evening Banquet.

A banquet was tendered to the officers of the allied associations Thursday evening, by the Founders' and Manufacturers' Supply Association, at Hotel Cadillac. F. B. Stevens acted as toast master and called upon several prominent foundrymen for addresses.

The feature of the banquet was the awarding of the prizes for the best exhibits which were displayed at the State Fair Grounds during the exhibition week. The prizes were presented by "The Foundry," for the best still exhibit and the best moving exhibit.

The committee making the awards was composed of Major Joseph Speer, Arthur T. Waterfall, H. A. Carpenter, and Stanley B. Flag.

The Solway Process Co., Detroit, re-



HARRY D. GATES,

Thos. W. Pangborn Co., New York, Vice-Pres. F. & M. S. Association.

presenting the firm of Baird & West, took the honors in the still exhibit contest, while the Tabor Mfg. Co., Philadelphia, won the prize for the best moving exhibit. Other companies obtaining honorable mention were: Arcade Mfg. Co., Carborundum Co., Roger

Brown Co., Detroit Foundry Supply Co., Mumford Molding Machine Co., Berkshire Mfg. Co., "Castings," Osborne Mfg. Co., and the Robeson Process Co.

Friday, June 10.

The following nominating committee brought in a report of new officers:



ROBERT B. THOMPSON,

Buffalo Pitts Co., Buffalo, President Associated Foundry Foremen.

W. H. M. McFadden, Pittsburg; J. J. Wilson, Detroit; Alfred E. Howell, Nashville; H. A. Carpenter, Pittsburg and L. L. Anthes, Toronto.

The report which was adopted nominating the following officers for the coming year:

President, Major Joseph T. Speer, Pittsburg Valve, Foundry & Construction Co.

Vice-Pres., No. 1 Dist., F. B. Farnsworth, McLagon Foundry Co., New Haven.

2nd—Walter Wood, R. D. Wood & Co., Camden, N.J.

3rd—W. A. Bole, Westinghouse Co., Pittsburg.

4th—Wm. Gilbert, Buckeye Foundry Co., Cincinnati.

5th—J. J. Wilson, General Motors Co., Detroit.

6th—T. W. Sheriff, Sheriff Mfg. Co., Milwaukee.

ROBERT B. THOMSON.

Robert B. Thompson, the president elect of Associated Foundry Foremen, is a Canadian by birth, being a native of Halifax, N. S. He has been connected with several large concerns in the eastern States. For several years he has been connected with the Buffalo Pitts Co., Buffalo, which is his present address.

7th—Alfred E. Howell, Phillips & Buttorf Mfg. Co., Nashville.

8th—A. N. W. Clare, Clare Stove Co., Preston, Ont.

Sec.-Treas.—Dr. Richard Moldenke, Watchung, N.J.

Founders' and Manufacturers' Association.

The annual meeting of the Founders' and Manufacturers' Association was held in Hotel Cadillac, Friday evening. A committee was elected to consider the advisability of incorporating.

The following officers were elected:

President—Geo. R. Raynor, Carborundum Co., Niagara Falls.

1st Vice-Pres.—Wilfred Lewis, Tabor Mfg. Co., Philadelphia.

2nd Vice-Pres.—E. D. Froman, S. Obermoyer Co., Pittsburg.

3rd Vice-Pres.—T. S. Hammond, Whiting Foundry Equip. Co., Harvey.

4th Vice-Pres.—Harry D. Gates, Thos. W. Pangborn Co., New York.

Trustees (for three years)—F. N. Perkins, H. M. Bougher, E. H. Stedman.

Secretary—C. E. Hoyt, Lewis Institute, Chicago.

Treasurer—H. S. McCormick, Pittsburg.

Trustees—F. N. Perkins, Arcade Mfg. Co., Freeport, Ill.; H. M. Bougher, J.



T. S. HAMMOND,

Whiting Foundry Equipment Co., Vice-Pres. F. & M. S. Association.

W. Paxson Co., Philadelphia; E. H. Steedman, Curtis Mfg. Co., St. Louis, Mo.

The nominating committee's report was presented by the chairman, E. A. Pridmore, Chicago. The other members of the committee were E. H. Mumford,

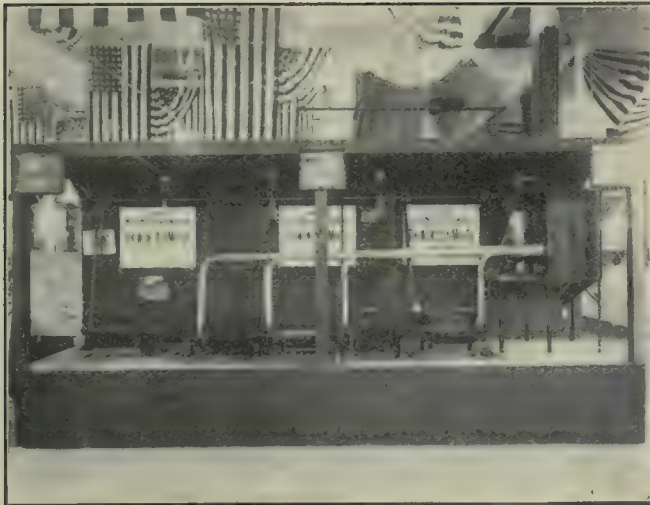

W. W. Sly Mfg. Co., Cleveland, O.

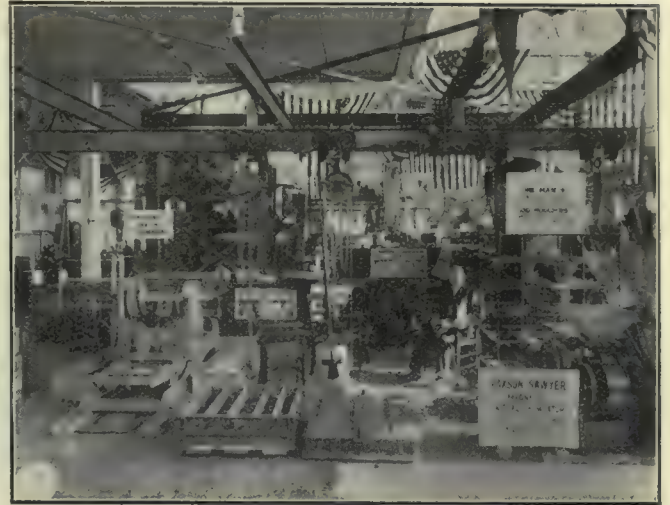

J. W. Paxson Co., Philadelphia.



T. J. Peterson Co., Chicago.



Berkshire Mfg. Co., Cleveland, O.



Arcade Mfg. Co., Freeport, Ill.



Cutler-Hammer Mfg. Co., Milwaukee, Wis.

Martin L. Heyl, W. C. Sly and John C. Pangborn.

Canadians Present.

There were a great number of Canadians present, but as all did not register the following list is not complete:

M. Chapman, Ontario Wind Engine and Pump Co., Toronto; Geo. Childs, James Stewart Mfg. Co., Woodstock;

J. H. Ainsborough, Toronto; J. Anderson, J. Fleury Sons, Aurora; L. L. Anthes, Anthes Foundry, Toronto; J. C. Armer, Toronto; Hugh Lamont, Toronto Testing Laboratories, Toronto; F. E. Laner, Warden, King Ltd., Montreal; J. Linklater, International Harvester Co., Hamilton; S. R. Logan, Waterous Engine Works, Brantford; J. E. Long, McKinnon Dash & Metal Co.,

Toronto; W. D. Varey, Western Foundry Co., Wingham; M. J. Walsh, Canadian Car & Foundry Co., Montreal; Fred Washburn, Taylor-Forbes Co., Guelph; G. H. Weaver, Dominion Foundry Supply Co., Montreal; Frank White and Arthur W. White, Geo. White & Sons Co., London; Robert Wilson, Hamilton; Joseph Wright, Dominion Radiator Co., Toronto; J. H. Fryer, Galt Malleable Iron Co., Galt; F. S. Ferguson, Canada Iron & Furnace Co., Montreal; Wm. Findlay, Findlay Bros., Carleton Place; E. B. Fleury, Hamilton Facing Mills Co., Hamilton; B. Geery, American Wheel Co. and Advance Thresher Co., Toronto; A. W. Given, Taylor-Forbes Co., Guelph; H. L. Gulline, Warden King Ltd., Montreal; W. J. Harris, Canada Metal Co., Toronto; G. C. Keith, editor Canadian Machinery, Toronto; G. Parry, National Iron Works, Toronto; Mr. McDonald, Industrial Commissioner, Guelph; and A. Knight, of Canadian Northern Ry., Winnipeg.

Entertainment for Ladies.

During the convention many ladies attended the sessions of the A.F.A. and A.B.F.A., listening to the papers and discussion. The visitors to the exhibition included a large number of ladies who showed their interest in the machinery and equipment on exhibition. The ladies were not forgotten at any time, and while the gentlemen were enjoying the smoker Tuesday night, the ladies were entertained at a theatre party.



Baird & West, Detroit, and Picands, Brown & Co., Winner of Foundry Loving Cup.

A. N. W. Clare, Clare Bros., Preston; A. E. Earsman, Earsman Bros., Toronto; P. A. Drummond, American Wheel Co. and Advance Thresher Co., Toronto; Geo. A. Drysdale, International Harvester Co., Hamilton; J. J. Cunningham, Western Foundry Co., Wingham; Thomas Davidson, Cockshutt Plow Co., Brantford; G. G. Noble, Dominion Radiator Co., Toronto; A. M. P. Irvine, Parker Foundry Co., Montreal; Thos. Jenkins, Dodge Mfg. Co., Toronto; Wm. K. Kennedy, the Wm. Kennedy Co., Owen Sound; H. O. Kerr and R. Kerr, Kerr Engine Co., Walkerville; F. W. King, McClary Mfg. Co., London; A. Oliver, Sheldon's, Galt; F. Painter, Standard Sanitary Mfg. Co., Toronto; A. Park, Park Bros., Chatham; N. K. B. Patch, Lumen Bearing Co., Toronto; J. H. Phillips, Pease Foundry Co., Toronto; W. F. Ralph, Canadian Machinery, Toronto; C. Rehder, Bowmanville Foundry Co., Bowmanville; W. G. Rogers, Erie Iron Works, St. Thomas; J. M. Ryan, Montreal Steel Works, Montreal; R. Savill, Taylor-Forbes Co., Guelph; J. G. Scully, Raymond Co., Guelph; Mr. Nunan, Raymond Mfg. Co., Guelph; H. Hertfelder, Dodge Mfg. Co., Toronto; A. P. Hilton, Taylor-Forbes Co., Guelph; A. R. Hocken, Taylor Forbes Co., Guelph; R. J. Hopper, Pratt, Litchworth Co., Brantford; Thos. Hopkins, Welch Stove Co., Guelph; Edward Hutchinson, Cockshutt Plow Co., Brantford; F. S. Campbell, Taylor-Forbes Co., Brantford; John M. Carrol, Hamilton; T. J. Best, Warden King Ltd., Montreal; F. Ben Bennett, D. Maxwell & Sons, St. Marys;

St. Catharines; D. O. McKinnon, Toronto; Geo. Merckling, McKinnon Dash Metal Co., St. Catharines; L. A. Mills, Western Foundry Co., Wingham; R. R. Mitchell, Robt. Mitchell Co., Montreal; J. K. Moffat, Moffat Stove Co., Weston; J. Morin, M. Moody & Sons Co., Terrebonne; J. F. Nellis, Chas. C. Kavin Co., Toronto; A. E. Smith, Montreal; E. Stanley, Ontario Wind Engine & Pump Co., Toronto;



Tabor Mfg. Co., Philadelphia, Winner of Foundry Loving Cup.

T. C. Stewart, Jas. Stewart Mfg. Co., Woodstock; A. G. Storie and F. Storie, Ontario Malleable Iron Co., Oshawa; A. H. Tallman, Tallman Brass & Metal Co., Hamilton; J. M. Taylor, jr., Taylor-Forbes Co., Guelph; S. Terrell, Raymond Mfg. Co., Guelph; H. V. Tyrrell, Canadian Machinery,

Parlor H at Hotel Pontchartrain was reserved for ladies by the Detroit Committee. Members of the Ladies' Committee were in attendance at all times to give information and assist the visiting ladies.

On Wednesday afternoon the ladies joined with the gentlemen in the exer-



Cleveland Wire Spring Co., Cleveland, O.

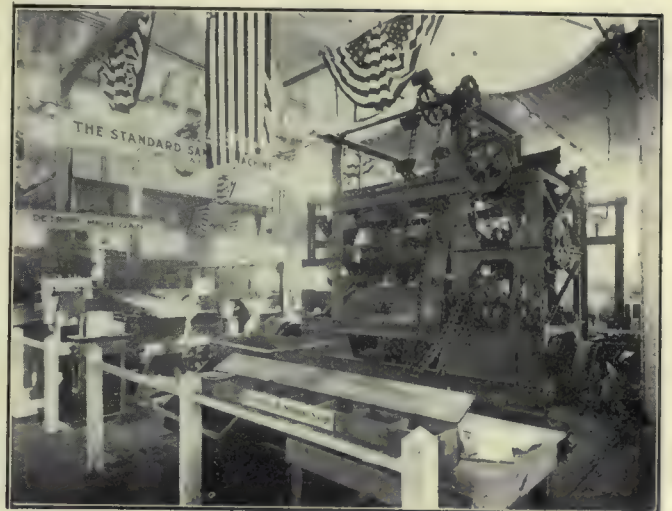

Standard Sand Machine Co., Cleveland.



Mumford Molding Mch. Co., New York,
Q. M. S. Co., Plainfield.



Jonathan Bartley Crucible Co., Trenton, N. J.,
Central Foundry Supply Co., Columbus, O.

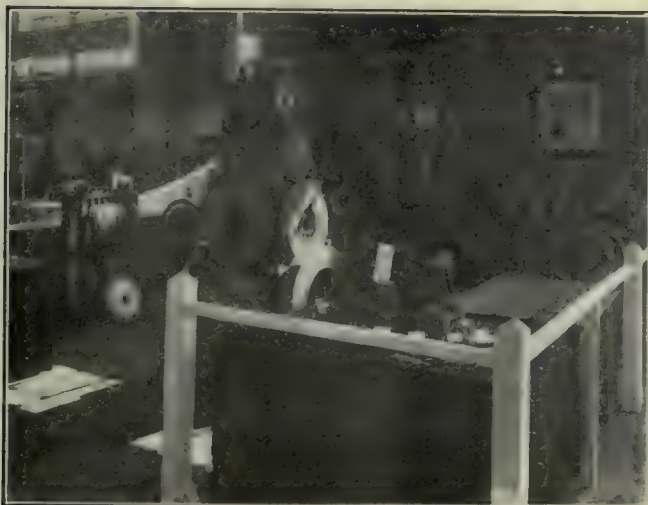

Carborundum Co., Niagara Falls, N. Y.



Monarch Engineering & Mfg. Co., Baltimore, Md.

sions on the Detroit River and Lake St. Clair.

On Thursday afternoon the ladies saw Detroit by automobile. After seeing many places of interest they were tendered a luncheon at the Yacht Club on Belle Isle.

Convention Committees.

The Detroit committee who had charge of arrangements were Dr. Frank T. F. Stephenson, Detroit Saw & Brazing Works, general chairman; A. Preston Henry, Standard Pattern Works, secretary; Frederic B. Stevens, chairman finance committee; J. J. Wilson, Cadillac Motor Car Co., plant visitation; J. B. Keightley, Great Lakes Engineering Co., reception; W. P. Putman, Detroit Testing Laboratory, technical papers; De La Motte Henry, Buhl Malleable Co., ladies; E. J. Woodson, Detroit Foundry Supply Co., entertainment; and Oliver Phelps, M. A. Hanna & Co., chairman boat ride committee. The excellent arrangements in connection with the convention meetings, exhibition and entertainment were due to the plans made and carried out by these gentlemen. Representatives from the Pittsburg Foundrymen's Association were on the ground, both during the convention and for months previous, observing the methods used in Detroit. This fact is a compliment to the excellent methods adopted by the Detroit Foundrymen.

THE EXHIBITS.

ANTHONY CO., 45 WEST 34th ST., NEW YORK.—Liquid fuel engineers, showed in operation oil burners for high and low pressure, pit crucible furnaces and tilting furnaces. J. M. Neill demonstrated the melting of brass with the Anthony furnace. N. W. Anthony and A. R. Anthony were also on the ground. In the oil furnace the flow of oil to the spindle is regulated by the oil valve as it passes through a very small hole in the plug at the end of the spindle. The oil is then caught up by a current of air completely surrounding this plug and caused to enter the furnace in a finely divided spray. Pressure is $2\frac{1}{2}$ to 3 oz. and a temperature of 2650 deg F. is obtained. The furnace is lined with $\frac{1}{2}$ in. asbestos and firebrick.

ARCADE MFG. Co., FREEPORT—Had a large exhibit in the main building. Edgar H. Morgan, Chas. Morgan, F. N. Perkins, W. C. Norcross, R. M. Burton, G. D. Wolfey, August Christen and Reeve Burton were on hand. Several machines were in operation including the Arcade Automatic Molding Machine, Modern Molding Machines, Arcade squeezers, Norcross jolting machines, Buck roll-over match plate and sand conveyors. There was also a demonstration of pattern plates. A Northern crane was used in connection with the exhibit.

AMERICAN BLOWER CO., DETROIT.—The special feature of the exhibit was a 24 inch ball, kept in the air by 1.58 in. pressure blower direct connected to a 40 h.p. motor, delivering air at an angle of 45 deg. A small blower with motor was also shown in the exhibit. In addition were Sirocco heating and ventilating system, Sirocco ventilating propellers and isolated power plant engine with dynamo direct connected to engine. R. T. Coe, M. L. Diver, B. E. La Follette, A. N. Kelley, and W. A. Fletcher were in attendance.

BOYER PATTERN PLATE & MFG. CO., CLEVELAND.—Represented by John T. Boyer, G. Knock and Chas. W. Brown their combination roll-over and squeezer molding machine. The entire mold is made in one operation when work of snap flask size is being produced.

BERKSHIRE MFG. CO., CLEVELAND.—Showed power riddles, flasks, automatic molding machines, etc. During the exhibition Berkshire hand machines were operated. This machine is intended for use where the output of different castings is limited and can be used on any style of patterns.

BROWN SPECIALTY MACHINERY CO., CHICAGO.—Showed their Hammer core machine which makes round, oval, octagon, slab and irregular cores up to three inches and square cores up to two inches. E. A. Rich, Jr., was in charge of the demonstration of the work that can be done with this core machine.

JONATHAN BARTLEY CRUCIBLE CO., TRENTON.—Lewis H. Lawton and S. H. Dougherty pointed out the merits of the crucibles, retorts, stoppers and other graphite specials, that were exhibited.

A. BUCH'S SONS CO., ELIZABETHTOWN, PA.—Made molds on the two Bush's jar and squeezer molding machines. They also showed patented aluminum snap flasks, method of mounting patterns for molding machine use, special cast iron flasks for gravity molding machine, etc. R. S. Buch and P. J. Potter had charge of the exhibit.

BROWNING ENGINEERING CO., CLEVELAND.—A miniature magnet in operation illustrating the work that may be accomplished with a Browning magnet. Literature on locomotive cranes, automatic grab buckets and hoisting and conveying material, was distributed. Photographs illustrated these several machines. H. E. Green was in charge of the booth.

BUCKEYE PRODUCTS CO., CINCINNATI.—Showed samples of parting compounds, brass flux, and foundry specialties. They were represented by Chas. J. Goehringer and E. H. Leisl.

BURROUGHS' ADDING MACHINE CO., DETROIT.—Adding and listing machines were shown, their uses and operation being demonstrated by F. H. Dodge and F. S. Wheeler. Their usefulness in connection with cost systems was also demonstrated.

S. BIRKENSTEIN & SONS, CHICAGO.—Had ingots of copper brass and babbit. They were represented by E. E. Berliner, J. B. Neilan and Harry Birkenstein.

CALUMET ENGINEERING WORKS, HARVEY—Had on exhibit tumblers, ladles, trolley system and a cupola model showing construction. H. W. Schulze, J. T. Krieger and C. A. Dugan were in attendance.

CHICAGO PNEUMATIC TOOL CO., CHICAGO—Had an air compressor in operation furnishing power. Also shown were pneumatic hammers, sand rammers, drills, grinders, etc. They were represented by J. F. Duntley, F. E. Lawson, R. P. James, W. C. Walker and G. W. Parker.

CARBORUNDUM CO., NIAGARA FALLS.—Carborundum aloxite wheels, rubbing bricks, sharpening stones, emery cloth and paper, were shown as well as crystals of carborundum. Wheels were operated on two grinding machines. G. R. Rayner, C. D. Sargent, F. B. Jacobs, H. A. Eaton and O. C. Dobson attended.

CENTRAL FOUNDRY SUPPLY CO., COLUMBUS.—Offered to supply free 250 lbs. Bull Run talc. Acme parting and Bull Run red facing are two of their specialties.

CLEVELAND WIRE SPRING CO., CLEVELAND, OHIO.—Had on exhibit steel shop and foundry barrels, sprue boxes, steel tote boxes, core trays, coiled wire springs and wire forms. J. W. Campbell was in charge.

CASTINGS, CLEVELAND.—Published by the Gardner Printing Co. The booth was in charge of H. M. Lane and R. I. Clegg, editors, and G.

H. Gardner, president, S. R. Lewis, S. G. Krake and Chas. G. Kissinger. On exhibit was a pig of Zug iron weighing 135 lbs. and also the exact amount of limestone, coke, ore, etc., to make the pig. There was also shown the equivalent amount of S., FeS., pig., P., Si., C in its composition and the amount of slag left from making such a bar. On exhibit was a cast iron tablet 3' x 5' with an address to President Lincoln in raised letters. It was made by the Moline Scale Co. Moline and glutine was used in making. Various other castings in grey iron and brass were shown including grey iron (rubber iron), fancy brass castings made by Yale & Towne, Cleveland, and castings of National Cash Register Co.'s cash register, sides with the original plaster of paris pattern.

CUTLER-HAMMER CLUTCH CO., MILWAUKEE.—Mr. Ludwig demonstrated the Cutler-Hammer magnet and its control by means of one erected in the book and placed in commission there.

CRECENT MACHINE CO., LEETONIA, OHIO.—Manufacturers of woodworking machinery showed the Crecent safety head for joiners. C. G. Wilderson was in charge of booth.

CANADIAN MACHINERY, TORONTO.—Represented by H. V. Tyrrell, W. F. Ralph and G. C. Keith.

DETROIT FOUNDRY SUPPLY CO., DETROIT.—Were represented by Edward J. Woodson, W. Bruce Howard, Wm. H. Chase, Wm. H. Fitzpatrick, Wm. W. Murray, Jas. C. Dissette and Chas. D. Yahne. Their exhibit included a core oven, oil burners, plating dynamos, buffing wheels, plates, chemicals, roll-over molding machine, shovels, crucibles, new eccentric adjustable clamps, aluminum snap flasks, blow torches, etc. A number of Wetmore patent glue heaters were shown. The heater may be equipped with a thermostatic valve which turns off the flow of gas as soon as the glue reaches the desired temperature and thereafter keeps the glue at the proper temperature.

WM. DEMMLER & BROS., KEWANEE, ILL.—Demonstrations were made of the Hewlett core machine which makes seven boxes per minute with one or more cores in each box. The sand is introduced into core box by compressed air at 75 lbs. pressure for oil sand mixtures and 100 lbs. pressure for ordinary sand mixtures. The Kewanee molding machine was also shown. H. L. Demmler had charge of the exhibit.

JOSEPH DIXON CRUCIBLE CO., JERSEY CITY.—They had on exhibit crucibles for both brass and steel melting, special shapes and formulae for various purposes, phosphorizers, stirrers, skimmers. Motor brushes and other graphite products were shown. The booth was a centre of interest, the crowd being entertained by the "Wiggle-Wagglegraph." It contained a magic mirror which made it impossible to draw a square with diagonals correctly. Dixon pencils were also distributed as well as a recent publication "Crucibles, their care and use." The purpose of the book is to uniform the user of crucibles as to their nature and characteristics, and give him suggestions as to their care and handling, which, if followed, will add to their efficiency and greatly prolong their period of usefulness. They were represented by Dudley A. Johnson, W. B. Allen, F. R. Brandon, L. Hoasis, F. Krug, John A. Cordit, L. M. Chase, C. D. McIntosh and Geo. Neighbor, John A. Cordit, manager of the Buffalo office, has charge of the Canadian territory.

DETROIT HOIST & MACHINE CO., DETROIT.—Had compressed air hoisting machinery on exhibition. A model in operation showed the principle of the hoist. J. C. Fleming, and F. B. Fleming were the representatives.

DETROIT TESTING LABORATORY, DETROIT.—They carry on the business of consulting foundrymen, metallurgists, chemists, etc. Associated with them in Canada is the Toronto Testing Laboratory, 18 Saturday Night Building. Representatives were W. P. Putman, J. D. Stoddard and Hugh Lamont.



Detroit Foundry Supply Co., Detroit.



Detroit Foundry Supply Co., Detroit, Mich.



J. D. Smith Foundry Supply Co., Cleveland.



Thos. W. Pangborn Co., New York City.



Castings, Cleveland ; Detroit Testing Laboratory. Detroit.



Falls Rivet & Mch. Co., Cuyahoga Falls.

STANLEY DOGGETT, NEW YORK—Representatives were W. S. Rupert, Wm. Busser and Stanley Doggett. They distributed samples of Doggett parting compound and literature on the various foundry specialties such as manganese dioxide, facings, etc.

FOUNDRY SPECIALTY CO., CINCINNATI—Represented by F. W. Weissman demonstrated the Graf roll-over match plate device, hingeless snap flask and skeleton snap weight or clamp. Their specialty is "Partive" and "Fluxine."

FEDERAL FOUNDRY SUPPLY CO., CLEVELAND—Showed samples of facings, core binder, etc. They were represented by W. J. Adams, Ralph Ditty and W. R. Beers.

FALLS RIVET AND MACHINE CO., CUYAHOGA FALLS, OHIO—The following Wadsworth machines were on exhibit at this booth; three improved stock, No. 1. $\frac{1}{2}$ to 3" improved core machine; No. 2 $\frac{1}{2}$ to 7" improved hand power core machine; No. 3 improved power core machine, improved sand mixing and compounding machine; No. 1 and 2 core cutting off and coning machine, improved core oven; all steel stock core racks; standard core prints in cabinets, and a group of Wadsworth vertical jarring core-forming machines making standard and chambered cores. This exhibit, which was in charge of Geo. H. Wadsworth and Geo. White, was shown under a structural iron frame making the line shaft and countershaft all self-contained, while the machinery was all running it was entirely separated from the building and was in operation every day during the convention.

FOUNDRY NEWS, NEW YORK—Albert Spies, Chas. E. Cornell, Jr.

GUTHRIE & HOWE, CINCINNATI—Polar flaming arc lamps made in Berlin, Germany, designed for both direct and alternation current were shown by P. H. Guthrie and C. G. Howe.

GOLDSCHMIDT THERMIT CO., NEW YORK—Have also a branch in Toronto. The method of making repairs with thermit was illustrated. Photographs showed many repairs made by this process of welding, patterns, expensive castings of all kinds, etc. They were represented by Henry S. Mann and J. G. McCarty.

HERMAN PNEUMATIC MACHINE CO., PITTSBURG—Had on exhibit Herman jarring molding machines, jarring molding machines with roll-over and pattern drawing device, jarring and stripping plate machine, combination jarring and squeezer machine. Demonstrations of molding were given. A Northern crane was erected and used in connection with the molding. In attendance were Martin L. Heyl, Chas. Herman, H. T. Fraunheim and John J. Lawlor.

HOWLEY DOWN DRAFT FURNACE CO., CHICAGO—Showed ladle heaters, Schwartz metal melting furnace for all metals in operation and the Hawley oil crucible furnace also in operation. H. J. Stow was in charge of the exhibit.

HANCK MFG. CO., NEW YORK—The three sizes of portable oil burners were shown also burners for lighting cupolas, ladle heaters, skin drying burners, torches, forges for annealing, brazing, pipe bending, heating rivets, etc. They were represented by A. B. Link, A. H. Stein, Willis C. Squire, and F. G. Squire. E. Stanley of the Ontario Wind Engine & Pump Co., Toronto, Canadian representative, was also in attendance.

HANNA ENGINEERING WORKS, CHICAGO—Had in operation screen shakers, revolving dumping riddles, mold dryers, riveters, and Rathbone multiple molding machine. They were represented by Wm. L. Laib and James T. Lee.

HILL & GRIFFITH CO., CINCINNATI—Deal in foundry facings, core and parting compounds, patent tamping head molders' shovels, bellows, brushes, etc. They were represented by John Hill, J. M. Glass, and M. Z. Fox.

HICKMAN, WILLIAMS & CO.—This company had only an office. Their plants are at Louisville, Chicago, Cincinnati, Pittsburg, St. Louis, New York, Philadelphia, Boston and Birmingham.

They manufacture pig iron, coke, steel, ferro-manganese, ferro-phosphorus, ferro-silican and silico-speigel. They were represented at the convention by H. E. Pierce, E. P. Hettiger, H. Black, John U. Byrd, T. C. Ward, F. S. Fears, J. B. Holloway, S. E. Frazee, Richmond Nicholas, R. B. Miller, T. L. Powell, T. A. Arthur, R. W. Kellow, W. L. Hoffman, B. P. Williams, Day Williams, John Daker, Jr., L. E. Paton, C. A. Reed, and L. H. Miller.

INGERSOLL-RAND CO., NEW YORK—Exhibited compressed air appliances applicable to foundry work consisting of motor-driven air compressor, pneumatic sand rammers, pneumatic chipping hammers, hoists, etc. W. H. Armstrong, W. A. Armstrong, Jas. Moran and James L. Kelly were in attendance.

E. KILLING'S MOLDING MACHINE WKS., DAVENPORT, IOWA—Had on exhibit the Killing foot-jarring rockover machinery, universal jarring machine and a No. 1 Killing auto squeezer duplex. The squeezer closes the mold automatically and also sifts sand, squeezes cope and drag, vibrates the pattern, clamps the flask, lifts cope, drops drag and closes the finished mold automatically.

T. P. KELLY & CO., NEW YORK—Had an office in the main building. They deal in foundry supplies.

KROESCHELL BROS. CO., CHICAGO—Had on exhibit Kroeschell-Schwartz gyrating flame crucible furnaces, tilting or stationary type, oil or gas fuel. Mr. Schwartz represented the company.

J. S. McCORMICK, PITTSBURG—Had a model power ramming machine, Deane pneumatic sand mixer, Blake wire straightener, 20th century molding machine and a continuous sand mixer. The two last were in operation. The sand mixer has a capacity of ten to fifteen tons per hour. The company was represented by J. S. McCormick, T. E. Malone and S. R. Costley.

MICHIGAN SMELTING & REFINING CO., DETROIT—Showed gates of castings, and finished castings made by companies using M. S. & R. Co. metal. Representatives were Joseph Stillman, Albert J. Hall, T. R. McNamee, S. R. Ginsburg and H. Levitt.

MONARCH ENGINEERING & MFG. CO., BALTIMORE, MD.—The Monarch rivet heater, Steele-Harvey crucible tilting brass melting furnaces were shown. The crucible is not removed from the furnace in pouring the metal. Monarch "Acme" portable core oven was also shown and a Monarch "Eclipse" bolt heating forge, water jacketed, operated by oil, gas or air. In attendance were David R. Steele, M. W. Woodburn, James H. Fowler, H. D. Harvey and Jas. J. Allen. This exhibit was in the tent, the furnaces being in operation each day during the week.

MUMFORD MOLDING MACHINE CO., NEW YORK—Had in operation squeezer with vibrator and match plate, high trunnion squeezer with vibrator and match plate, power ramming plate pattern, power ramming machine with starting power pattern draft, plain jolt ramming machine operated in connection with hoist for rolling molds and sand pattern guide for match plates. Mr. Mumford was in attendance.

BENJ. MIDDLEDITCH, DETROIT—Showed a power sprue cutter the wearing parts of which are made of tool steel. Cutters are of tool steel $1\frac{1}{2}$ " x $\frac{3}{8}$ " and cut a piece equivalent to $\frac{3}{4}$ " square common yellow brass. A polishing machine was shown and a tilting tumbling barrel for tumbling brass and bronze castings. In the latter machine bushings are renewable, and outer end of shaft carrying pulleys and gear is supported with a heavy bracket keeping small gear in proper mesh with large gear. Brass founders' bevel flasks completed the exhibit. The representatives were Benj. Middlehitch, P. De Vines and S. Laffrey.

MILLERS' PRODUCTS CO., CHICAGO—Had samples of Black Diamond Bore Compound and several grades of foundry flour. C. B. Spaulding was in charge.

METAL DROSS ECONOMY CO., BRISTOL, CONN.—Metal dross extractor was shown. The skimming tank consists of a cast iron box 20 x 22 ins., covered with a steel top. The dross from the crucible is skimmed into this tank which is kept full of water. The separator consists of wire screens. Tests show that this machine has saved a great amount of metal where tried out. They were represented by A. L. Hoasis and W. H. Carpenter.

METAL INDUSTRY, NEW YORK—Represented by Palmer H. Langdon, L. J. Krom, T. A. Trumbour, E. B. Fritz and F. J. Huntley.

NORTHERN ENGINEERING WORKS, DETROIT—In the centre of the exhibit was a cupola set on a turntable to show the ease of operation of the turntable. On the top of the turntable and beneath the cupola was a mirror so that the interior of the cupola was easily seen. Probably the most interesting feature of the exhibit which included a great number of foundry supplies and equipment was a model of a crane trolley in operation. This was complete with motor, the gears were enclosed and all the features of the Northern crane were included in the model. The representatives were W. G. Chesebrough, Walter Robinson, W. S. Reid, W. H. Standart and Geo. A. True.

NATIONAL CORE OIL CO., BUFFALO, N. Y.—Deal in high grade core compounds and foundry specialties. C. H. Cotton, P. L. Crandall.

OSBORN MFG. CO., CLEVELAND—Molding machines, etc., were shown in operation including rock-over drop-draft molding machine, adjustable flask stripping moulding machine and rock-over jolt and plain jolt molding machines. In the jolt machines the length of stroke and hardness of blow to be struck are always in control of the operator. Representatives were H. R. Atwater, F. D. Jacobs, E. T. Doddridge, J. H. Galloway and J. C. Boynton.

S. Obermayer Co., Chicago—Were in the booth with the Whiting Foundry Equipment Co. They were represented by S. T. Johnston, F. H. Dodge, F. J. Brunner, O. J. Peterson, J. E. Evans, C. M. Barker, W. M. Fitzpatrick, E. D. Frohman, H. F. Frohman and G. H. Kersting.

OLIVER MACHINERY CO., GRAND RAPIDS—Showed a great number of wood working machines such as pattern makers' planers, jointers, band saws, circular saws, Sanders' wood trimmers, lathes, borers, grinders, etc. Of greatest interest was the Wadkin milling machine in which milling is applied to the making of patterns. J. W. Oliver, A. N. Spencer, J. P. Schmidt and W. Y. Mentzer represented the company.

J. W. PAXSON CO., PHILADELPHIA—Manufacture cupolas, ladles, etc. On exhibit in operation was a rock-over pattern-drawing molding machine. This Barker type is for large and small patterns and patterns on plates or match boards may be used. The representatives were H. M. Bougher, Geo. Moore, A. W. Moyer, I. F. Kremer, W. Scott Thomas, W. T. Nicholson, and W. Baetty.

T. J. PETERSON CO., CHICAGO—Showed cores made by a number of engine manufacturers for gas engine cylinders using their core oil. They were represented by Jas. Kerr, H. S. Peterson, J. Purvis, A. B. Elwes.

HENRY E. PRIDMORE, CHICAGO—Exhibited at the Foundrymen's Convention, Detroit, thirteen years ago, being the only exhibitor at that time of molding machines. There were on exhibit small square stand stripping plate machine and patterns, large square heavy double shaft stripping plate machine and patterns, stove plate rock-over machine and patterns, rock-over drop machine fitted with automobile patterns, power ramming rock-over drop machine and patterns, machine were operated during the convention. Edward A. Pridmore, R. E. Turnbull, D. F. Eagan and W. W. Miller were in charge.

THOMAS W. PANGBORN CO., NEW YORK—Had on exhibition their modern high pressure sand blast systems. In addition they had sand separators equipped for either belt or air drive. Representatives were John C. Pangborn, Harry

D. Gates, Jesse J. Bowen, Willis S. Doane, Alfred L. Holmes, Foster J. Hull and Raymond F. Smith.

PENTON PUBLISHING CO., CLEVELAND—Publishers of Foundry and Iron Trade Review had a booth furnished with easy chairs for visitors and decorated with palms, etc. The two loving cups presented by them to the Exhibitors' Association were on exhibit. These were presented to the companies having the best exhibits. They were represented by John A. Penton, A. O. Backert, C. Vickers, W. A. Ten Winkel, R. E. Donmore, D. C. Warren, W. B. Robinson, J. C. Eppens and F. J. Ryan.

PARKER BROS. CO., DETROIT—They are the selling agents for the Ohio Sand Co., Conneaut, Ohio, the Ayres Mineral Co., Zanesville, O., L. K. Brown, Zanesville, and the Interstate Sand Co., Zanesville, all miners and shippers of all grades of molding sands. In attendance were E. M. Ayres, L. K. Brown, U. E. Kanavel, E. R. Wilson, F. E. Gordon, Arthur S. Barrows and W. R. Thompson.

Q. M. S. CO., PLAINFIELD—Had on exhibit cylindrical air hoists, hand power traveling cranes, I beam trolley and I steel foundry saw. R. H. Post and F. R. Phillips attended.

ROBINSON AUTOMATIC MACHINE CO., DETROIT—Showed automatic machines for metal polishing.

ROCKWELL FURNACE CO., NEW YORK—Showed photographs and blue prints of oil, coal and gas furnaces, and burning appliances. W. S. Quigley and A. L. Stevens explained the features of these appliances, etc.

ROGERS, BROWN & CO., CINCINNATI—Besides Cincinnati there are offices at New York, Chicago, Buffalo, Pittsburg, Cleveland, Boston, St. Louis, Birmingham and Philadelphia. They manufacture pig iron and coke. Their exhibit showed several grades of pig iron with numerous unusual castings made from pig iron. Henry B. B. Yergason was in charge of the exhibit. In the background of the exhibit was a large sign of colored lights, the lights representing the furnaces and coke districts in which the company is interested and from which are obtained the different grades.

ROBESON PROCESS CO., AU SABLE FORKS, N. Y.—Both the head office and main works are at Au Sable but there is also a plant at Covington, Va., manufacturing glutin core binder. Recently its manufacture was begun at Grand Mere, P. Q., and Francis Hyde, Montreal, were appointed Canadian agents. Small trees surrounded their booth, illustrative of the Glutin trade mark.

SAND MIXING MACHINE CO., NEW YORK—Showed in operation a machine for cutting mold. ing sand and for mixing core sands and facing sands. V. E. Minich, John Bradley and B. F. Doup were in charge.

J. D. SMITH FOUNDRY SUPPLY CO., CLEVELAND—Showed natural draft furnaces, aluminum melting furnace, rolling drawer coke oven, sprue cutter, water tumbler, grinder, sand blast installation and three different styles of molding machines. Representing the company were P. G. Smith, J. S. Smith, M. S. Finley, Jos. Harrison and F. A. Coleman.

FREDERIC B. STEVENS, DETROIT—The exhibit was of interest and attracted much attention on account of the "Dummy" operating the Stearns inolding machine. There was also shown a sand blast machine complete, a Noble's electro-magnetic separator, Spanish felt wheels, cotton buffs, etc., and a Noble magnetic separator. Those in attendance at the booth were Frederic B. Stevens, J. M. Moyers, W. J. Cluff, A. T. Wagner, J. Hughes, H. Kringner and Geo. B. Bell. Mr. Bruce, of the Bruce Foundry Supply Co., Toronto, the Canadian agent of Frederic B. Stevens, was a visitor to the convention and made this booth his headquarters. Among the souvenirs given by F. B. Stevens were the elephant and the donkey "barometer."

STANDARD SAND & MACHINE CO., CLEVELAND—Showed a Standard combined rolling and blending machine in operation. All of the material entering the drum receives eighteen uni-

form rollings in passing through the machine. H. E. Boughton, J. A. Boughton and T. J. Morgan are the representatives.

WM. SELLERS & CO., INC., PHILADELPHIA—A centrifugal sand mixing machine was in continuous operation during the convention. A drill grinding machine was also shown. Edward L. Holljes was in charge demonstrating the sand mixing machines, machines driven from overhead pulley and with motor drive being shown.

W. W. SLY MFG. CO., CLEVELAND, OHIO—This exhibit attracted considerable attention on account of the novel exhibit of cleaning mills cinder mills, etc. These were complete in every detail and showed to advantage the good features of the cleaning mills. Photographs of other machines were also shown. W. W. Sly and W. C. Sly, were at the convention and assisted by H. R. Morse and D. A. Livensparger, took much pleasure in demonstrating the salient features of the equipment they had on exhibition.

STERLING WHEELBARROW CO., MILWAUKEE—Had special rolled steel flasks on exhibition, these being demonstrated by I. R. Smith and H. G. Mindrum.

SOLVAY PROCESS CO., DETROIT—This coke is made by the Solvay process at Detroit, Chicago and Milwaukee. The selling agents are Baird & West, Detroit and Picards, Brown & Co., Chicago and Milwaukee. They were represented by G. A. T. Long, J. A. Golligan, B. T. Bacon, Edward R. Stoughton. The booth was artistically decorated with palms and flags with a background wall of Solvay coke.

TABOR MFG. CO., PHILADELPHIA—Received the cup for having, in the opinion of the committee the best exhibit in motion. Standard squeezing machines both power and hand, were shown in operation. The shockless jarring ma-

chines received a great deal of attention. These were described in the February issue. It is essentially a sand-packing machine capable of ramming any mold in short time. John T. Ramsden, C. W. Coleman, J. H. Coleman, C. H. Ellis and Wilfred Lewis were in attendance.

UNITED STATES GRAPHITE CO., SAGINAW, MICH.—Made their room a rest room. Their specialties is plumbago foundry facings. In attendance were H. C. Woodruff, Frank B. Godard, J. G. Drought and R. A. Corrigan. These gentlemen supplied the visiting ladies with carnations.

WHITEHEAD BROS. CO., NEW YORK—Had an office in the main building, deal in foundry supplies.

J. B. WISE, WATERTOWN—Showed in operation the "M.R.V." brass melting tilting crucible furnace, permanent crucible, using coke as fuel.

WALTER McLEOD & CO., CINCINNATI, OHIO—Buckeye and blast machines both pressure and suction types, compressed air sprayers, babbitt and lead portable melting furnaces, oil burners for cupola lighting, skin drying molds, brazing, etc., were shown. They were represented by the Obermayer Co.

WHITING FOUNDRY EQUIPMENT CO., HARVEY, ILL.—Had a large centre stand to which were attached frames containing photographs of the various foundry plants they have installed and equipment they manufacture. These include cupolas, tumblers, ladles, elevators, air hoists, sand sifters, brass furnaces, turntables, trucks, core ovens, electric traveling cranes, etc. They were represented by C. A. Hardy, P. A. Dratz, R. H. Bourne, F. A. Rundle, Crad Hughes, T. S. Hammond and W. Mayor. The Dominion Foundry Supply Co., Montreal and Toronto are Canadian agents and Mr. Weaver, of this company was in attendance at the convention.

INDUSTRIAL and CONSTRUCTION NEWS

Establishment or Enlargement of Factories, Mills, Power Plants, Etc.; Construction of Railways, Bridges, Etc.; Municipal Undertakings; Mining News.

Foundry and Machine Shop.

BRANTFORD.—Tenders were called for the purchase of the Burrill Foundry, Grey St., which has been used for 2 years.

BRANTFORD.—Harry Cockshutt, general manager of the Cockshutt Plow Co., announces that an expenditure of between three and four hundred thousand dollars will be made on new ad-

ditions to the company's plant and a staff of approximately 1,200 men will be employed, an increase of between 400 and 500 on the present number. The following buildings will be built in Brantford:—Warehouse, six storey building, 150' x 60'; experimental dept., four storey building, 65' x 64'; machine shop and erecting room, three storey building, 106' x 60'; casting storage and paint shop, three storey building, 105' x 60';

The Utilization of Wood Waste by Distillation

A general consideration of the NEW INDUSTRY, including a full description of the distilling apparatus used and the principle involved, also methods of chemical control and disposal of the products, first edition illustrated by seventy-four engravings, 156 pages. This book is cloth bound, it will be sent to any address post paid on receipt of \$3.20.

MAKE SOLIDIFIED PURE MILK VACUUM DISTILLED SOLID TABLETS WITH

Industrial Alcohol Stills, 5 Gal. Tax-Free, \$135.00, pays for itself every Month. 75 to 500 Gal. Stills installed under guarantee. Alcohol Solidified, 33 samples Solid Alkaloid Cubes, 194 proof, post-paid for \$1.00.

WOOD WASTE DISTILLERIES COMPANY

Wheeling, W. Va.,

U.S.A.

BETTER RESULTS AT LOWER COST

can be secured for any class of castings by arranging your mixtures by analysis. Years of practical experience in foundry work are at your service when you consult with

The Toronto Testing Laboratory, Limited

18 SATURDAY NIGHT BUILDING, TORONTO
EXPERT FOUNDRYMEN, METALLURGISTS, CHEMISTS
TESTS OF METALS, FUELS, CORES, OILS, Etc., AT REASONABLE PRICES.

BABBITT METALS

FOR ALL PURPOSES

LUMEN BEARING COMPANY
BUFFALO TORONTO

INFORMATION

about every conceivable subject finds its way into the newspapers. The function of THE CANADIAN PRESS CLIPPING BUREAU is to collect ALL the items of information appearing in Canadian newspapers about any subject YOU are interested in. Our service is thorough. We don't miss an item. If you want ALL THE CURRENT INFORMATION about a pet subject, we can supply it at the lowest cost. By using our service you can KEEP POSTED on any subject.

WRITE FOR OUR FREE BOOKLET

THE CANADIAN PRESS CLIPPING BUREAU

232 McGill Street, Montreal

10 Front Street E., Toronto

HERE IS A SPLENDID

Sensitive Column Drill

For drilling holes up to 5/16 of an inch it gives remarkable satisfaction. The spindle has two speeds and is driven by a 1" flat belt. It is relieved of all belt strain, is counter-balanced and provided with means for taking up wear. As the column is graduated by a vertical line its full length, the centre of the table may be set in line with the spindle at any point of vertical adjustment. A cup centre is furnished with each machine as a substitute for the table in centreing small work. *Write for Circular and Price.*

**D. McKENZIE**

9 Nottingham Street

GUELPH, ONT.

**BEST
LEATHER
BELT
MADE**



TORONTO

ST. JOHN, N.B.

MONTREAL

WINNIPEG

VANCOUVER

pattern storage, three storey building, 50' x 40'; foundry, 215' x 70'; engine gang structural shop, 192' x 50'; blacksmith shop, 154' x 70'; iron storage building, 128' x 100'; shear shop, 100' x 32'; transformer station, 14' x 12'; cupola house, 52' x 32'. Besides twelve new structures, either separate buildings or additions, three large new warehouses will be erected at Brandon, Saskatoon and Calgary. The large warehouse at Regina will also be added to, making in all practically sixteen new buildings to be put up this year by the Cockshutt concern.

BRIDGEBURG.—The Norcross Marble Co., and Monitor Harrow Co., are looking for sights here.

GUELPH.—The Chapman Double Ball Bearing Co., Toronto, were given an order from the Taylor Forbes Co., for the fitting of their entire plant with double ball bearings.

HESPELER, ONT.—The Chapman Double Ball Bearing Co., Toronto, are equipping the balance of the R. Forbes Co. plant with double ball bearings. About four years ago one department was equipped and gave good service.

NELSON, B.C.—The Nelson Iron Works, has taken over the business and stock of the Rossland Engineering Works, Rossland B.C., and will succeed that company as British Columbia agents for the Sullivan Machinery Co., Chicago.

OSHAWA.—Fittings, Limited, have purchased the adjoining property and will extend. Their annual pay roll is now over one million dollars.

OSHAWA.—The McLaughlin Carriage Co., have let the contract for a 300 ft. extension to their automobile department. Geo. McLaughlin reports that they require 2,500 h.p. at once and in a short time more will be needed. They have bought 43 acres near their present property.

PORT ARTHUR.—Recognizing the increase in shipping at the head of the Great Lakes, the Western Dry Dock & Shipbuilding Co. now have under construction a \$1,250,000 dry dock and shipbuilding plant. This will be capable of handling the largest boats at present on the lakes, and the keels for two 600-foot freighters are expected to be laid as soon as the plant is far enough advanced for same.

This work will entail a large amount of machinery, as there will be a complete boiler shop, rolling and punching shops, pattern shop and foundry. It will employ at least 500 hands when in complete operation. At the present moment about 200 men are on the ground on the construction work.

TORONTO.—It is announced that the head offices of the Ontario Iron and Steel Co. and the Page-Hersey Tube Works will be moved from here to Welland and will be located along with the factories at that place. A fine brick office is being erected.

WINDSOR.—The council has voted to sell the Regal Motor Co., Detroit, sufficient ground now owned by the municipality to enable a good-sized factory to be erected, with provision for future growth.

WINDSOR.—The Paterson Automobile Co., of Flint, Mich, has purchased ground in Windsor, and will establish a Canadian branch. The buildings now on the property will be remodeled at once, and work started under the supervision of T. G. Ferris.

Industrial Notes.

BRANTFORD.—Austen Bros., who have been carrying on a pattern-making business, are forming the Austen Bros. Stove Co., to manufacture a new stove patented by them.

BRANTFORD.—The Brantford Emery Wheel Co., are extending their lines by taking up the manufacture of vitrified emery wheels as well as the silicate wheel they have been manufacturing for some time.

CAMPBELLTON, N. B.—Letters patent have been granted to the McLennan Foundry & Ma-



Canadian Hart Wheels
442 Barton St. East, Hamilton
Corundum and Emery Wheels
Grinding Machines, Beaver Oil Stones.

JOHN J. GARTSHORE
83 Front St. W., Toronto
RAILS and SUPPLIES
New and Second-hand
For RAILWAYS, TRAMWAYS, Etc.
Old Material Bought and Sold.

STEELCRETE
EXPANDED METAL
REINFORCEMENT for CONCRETE FLOORS and ROOFS.
The most reliable bond for all varieties of concrete slab.
WHITE FOR HAND BOOK AND SAMPLES
Competent Engineering staff in charge of construction.
Expanded Metal & Fireproofing Co., Limited
100 King Street West, TORONTO



Do You Want
a reliable chuck—one that will answer every call you may make upon it? Then get the
IMPERIAL CHUCK.
It's just as good as care, skill and good materials can make it, and we want you to try it. May we send you one on
30 Days' FREE TRIAL?
If it won't answer every test you can apply, send it back at our charge.
Write us to-day.
Ker & Goodwin
Brantford, Canada

chine Works here, with a capital stock of \$59,000. They will carry on a general engineering, foundry and machine business.

AMHERST, N. S.—Fire gutted the works of the Malleable Iron Co. The building is brick and is 200 feet long by 60 feet wide. In the past six months the works have been fully occupied, employing one hundred men, making the malleable castings for the car works at Amherst and in Montreal.

BRANTFORD.—Brantford Scale Co., Ltd., is applying for a \$40,000 charter to manufacture scales. M. Herod, of Herod & Co., is the promoter.

CHATHAM.—The Anhut Motor Car Co., Detroit and Chatham, will in July commence the manufacture at their branch here, of cars for next year's Canadian trade.

GRIMSBY.—The Hall Zryd Foundry Co. will build a new foundry, if the town grants them the loan they ask for.

HAMILTON.—The National Fireproofing Co., of Canada, will locate in Canada, with headquarters at this place, where 125 acres of land have been secured, on which a plant will be erected to cost \$1,000,000.

HAMILTON.—The International Harvester Co. of America and the Oliver Chilled Plow Co. of Canada, both Hamilton firms, have completed an arrangement whereby the International will handle the entire sale of the Oliver company.

HAMILTON.—The following local companies will either build or make additions to their plants and factories at that place: The International Harvester Co., additions, \$500,000; E. T. Wright Co., \$11,000; Canadian Westinghouse Co., \$35,000; Sawyer-Massey Co., \$11,000; Chipman-Holton Co., \$8,000; Princess Underwear Co., \$3,000.

LONDON.—Wortman & Ward's had a \$30,000 fire. The destroyed shops will be rebuilt at once.

LONDON.—The Labatt Mfg. Co., have taken up brass molding, the organisation for which is now progressing.

MONTREAL.—Plans have been filed at Ottawa, by F. Orr Lewis, president of Lewis Bros., Montreal, Canadian agents of Vickers, Sons & Maxim, for a \$2,500,000 shipbuilding and ship repairing plant to be built by this English firm in Montreal. It will be located on the shore of the St. Lawrence, near Longue Pointe, and will include a floating dry dock, three large berths for the repairing and building of steel vessels, machine shops and plant capable of doing the heaviest construction work.

MORRISBURG.—The Morrisburg Tack Mfg. Co. have now a new board of directors, composed of Andrew Broder, H. H. Bradfield, W. H. McGannon, William Eager and C. B. Russell. Those retiring from the board were George N. Hickey, J. H. Mullin and Irwin Hilliard. At a meeting of the directors William Eager was elected president, H. H. Bradfield, secretary, C. B. Russell, managing director.

NEW GLASGOW.—Two new buildings costing \$100,000 will be erected at this place by the Nova Scotia Steel Co., in the near future. It is expected that the company will install machinery for the turning out of products other than those now manufactured.

NEW WESTMINSTER.—It is stated that large car building shops will be established on this coast by the C.N.R. and that the site will likely be opposite the mills of the Fraser River Lumber Co.

NORTH SYDNEY, N. S.—The machine shops and forge of R. Musgrave & Sons were destroyed by fire. Loss, about \$20,000.

OSHAWA.—The McLaughlin Carriage Co. contemplate a large addition to their works to cope with the tremendous demands for the McLaughlin-Buick automobiles.

PETERBORO.—A new machine shop will be erected at the Canadian General Electric Works, estimated cost about \$100,000.

Grey Iron Castings
STRONG CASTINGS, PROPERLY MADE TO MACHINE EASILY.
Wm. Hamilton Co., Ltd.
PETERBORO, ONT.

OPAL GLASS TILING
FOR WALLS OF MACHINERY AND POWER HOUSES
Most approved material.
TORONTO PLATE GLASS IMPORTING CO'Y
PLATE AND WINDOW GLASS
135 to 143 Victoria St., - Toronto



Oil Tempered Steel Springs
—for every purpose and the best for each use.
—Special styles of all kinds to order.
THE CLEVELAND WIRE SPRING CO.
Cleveland, Ohio.

MAPLE LEAF
STITCHED COTTON DUCK
BELTING
DOMINION BELTING CO. LTD.
HAMILTON CANADA

BENCH POWER PRESS

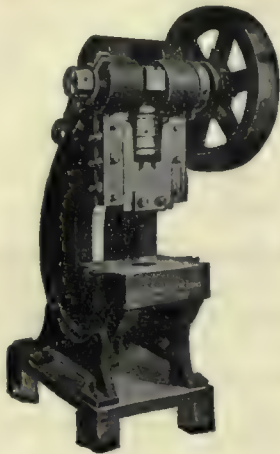

New Design

Particularly adapted for small, quick work, to take place of foot presses.

Write for Prices.

W. H. Banfield & Sons

MACHINISTS, DIE AND TOOL MAKERS
120 Adelaide Street West
TORONTO - - - CANADA

Special Taps Special Dies Special Reamers

Unless you have special appliances, you can get these tools from us better and cheaper than you can make them.

We have the equipment and the experience. Ask us for prices.

A. B. JARDINE & CO.
HESPELER, ONT.

REDCLIFFE, ALTA.—N. H. Bolton, of Minneapolis, will build a foundry and machine shop here.

SAULT STE. MARIE.—The entire plant of the Northern Foundry and Machine Co., comprising the machine shop, foundry, and moulding department, was destroyed by fire. It was the largest of the independent industries in the city, employing from 25 to 50 hands. The loss is about \$30,000, mostly covered by insurance.

SASKATOON.—The Saskatoon Machine and Foundry Co., made their first blast early in June. Everything in the line of cast iron will be made. Brass molding will also be carried on extensively.

PETERBORO.—The Peterboro Lock Co. are making a large addition to their factory and the equipment is also being added to by several new presses. The offices have been remodelled and many new designs of locks are being added to the company's output.

ST. CATHARINES.—The Russell Machine Co., which was burnt out by a recent fire, has rebuilt. Since the fire their business has increased considerably. They intend taking up the manufacture of special appliances in the near future.

ST. CATHARINES.—The St. Catharines Brass Works which suffered a complete loss by fire recently have rebuilt their plant.

ST. CATHARINES.—The John Deer Plow Co. contemplate locating their Canadian branch at this place.

STRATFORD.—The plant of the Ontario Brass and Copper Co., which has been doing business at 491 King St. West, Toronto, has been purchased by the Crown Electric Co., of this city, and will be removed here as soon as the local factory is ready.

VANCOUVER.—The machine shop owned by Twohey & Turpin was totally destroyed by fire on June 16.

WELLAND.—The head offices of the Ontario Iron and Steel Co., and the Page-Hersey Tube Works, are to be moved from Toronto to Welland, where the factories are now located. A new brick office building is under erection for the office staff of twenty who will go to Welland.

WELLAND.—The Electro-Steel Co., will build a plant here.

WINNIPEG.—Permits were issued to the Canadian Pacific Railway Company for new car shops at \$65,000.

WINNIPEG.—The McClary Mfg. Co. have purchased additional property to the extent of 100 feet to 150 feet at the rear of their warehouse on which a temporary storage shed will be erected at once. The company intend building a large warehouse in connection with the present building in the course of a few years.

Municipal Enterprises.

LA TUQUE, QUE.—The council here will call for tenders for the construction of a waterworks system. Estimated cost, \$300,000.

NEW WESTMINSTER.—Tenders will be received here for the laying of about 14 miles of 25-inch riveted steel water mains and about 7,780 feet of 12-inch and 7,500 feet of 13-inch lap-welded pipe.

POINT GREY, B. C.—The council are considering projects for an appropriation of \$500,000 to cover the cost of reservoir and site and the laying of mains. A by-law for \$250,000 will also be introduced for sewerage works.

TORONTO.—Chipman & Power, of this city, have been engaged as designing and superintending engineers in connection with the proposed waterworks and sewerage systems at Dauphin, Man.

ST. JOHN, N. B.—City Engineer Murdoch, has estimated the cost of a new incinerator plant from \$50,000 to \$100,000.

WELLAND.—The Water Commissioners have recommended to council the submitting of a by-law to raise for waterworks improvements \$60,000.

"GLOBE" TIME RECORDERS



are made in Canada by expert mechanics. They are accurate, simple in construction, strong, and of good chaste appearance. They will record with absolute accuracy the arrival and departure of your employees (TO THE MINUTE), making you pay for what you get and no more. All lates and short time marked in red, regular time in green. The small cut at the top illustrates the WEEKLY MODEL, an entirely automatic recorder requiring no attention whatever during the week, as all changes, etc., occur automatically (DONE BY CLOCK WORK). The DAILY MODEL is shown in the cut at the bottom. This recorder is being used mostly in large shops, etc., where a large number of hands are employed. With the "GLOBE" TIME RECORDERS only one operation is required as against five with most others.

Inspection may be made through the glass sides of the case, but tampering with records is impossible, no danger of having soiled, torn or lost records when same are unfavorable, as is the case with all CARD CLOCKS. We are now manufacturing over 224 DIFFERENT TIME RECORDING CLOCKS, and are in a position to meet the requirements of any business. Write us about your needs and let us suggest what will best meet with your requirements. WE SOLICIT YOUR ENQUIRY.

W. A. WOOD, Manufacturer

Head Office and Factory: 40 St. George St., Montreal

Branch Offices:

19 Bleury St., Montreal

65-67 Victoria St., Toronto

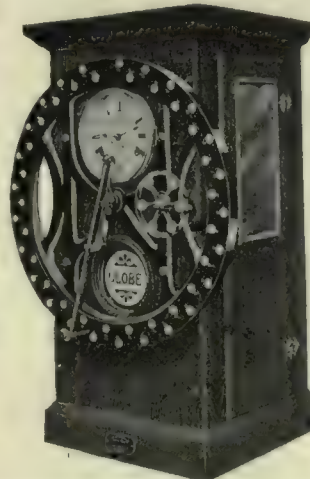

Electrical Notes.

BROCKVILLE.—In accordance with the by-law recently passed by the ratepayers providing for an expenditure of \$50,000 for improvements and extensions to the light and power plant, the commissioners have awarded tenders for two new steam engines and electrical equipment. Lawrie & Lamb, Montreal, were awarded the contract for the steam engines, and Kilmer, Pullen & Burnham, Toronto, will supply the electric equipment.

CALGARY.—Plans are being prepared for a power plant to cost \$80,000.

CALGARY.—The ratepayers carried the \$70,000 electric light plant extension by-law.

CARGILL, ONT.—The power house was burned early in June.

CALGARY.—Tenders will be received until July 12 for one 750 B.H.P. engine, 300 r.p.m., with condenser; also one 600 k.w.d.c. 600 volt generator switchboard, etc. H. E. Gillis city clerk.

DAUPHIN, MAN.—The \$11,000 by-law for electric light purposes was carried.

FARNHAM.—The ratepayers have approved of a by-law to raise \$100,000 for the erection of a dam and for general power development work.

FORT FRANCES, ONT.—The Minnesota & Ontario Power Co. have been granted a right by the Dominion Government to export 3,500 horsepower, or half of the total now developed.

MONTREAL.—The General Electric Co., of Sweden, have been awarded the contract for electrical equipment required for the Jacobs Building sub-station of the Dominion Light, Heat & Power Co. One 150 h.p. motor generator set and one 350 k.w. engine type generator will be installed.

MONTREAL.—The Canadian Westinghouse Co. have secured the contract from the Quebec Railway, Light, Heat & Power Co. for this season's transformer requirements. Also for 25,000 volt lightning arresters, disconnecting switches and choke coils.

INGERSOLL.—Two by-laws were carried, one to raise \$39,800 to acquire the plant of the Ingersoll Power & Light Co. and the other to raise \$15,000 to make improvements and extensions to plant.

MONCTON, N.B.—The agreement prepared by the city council with the Street Railway Electric & Gas Co. for the leasing of the city lighting plant for thirty-nine years was endorsed by the ratepayers.

PETERBORO.—The Peterboro Light & Power Co. will erect a power house at Auburn to cost about \$150,000.

POINT GREY, B.C.—The B.C.E.R. agrees to supply this municipality with light for ten years. Five hundred electric lights will be installed.

PORT ARTHUR.—The by-law for \$10,000 for extension of the electric lighting system was carried.

SASKATOON.—The Saskatchewan Power Co. will build a generating plant 12 miles below this city at an estimated cost of \$1,000,000.

STAVE LAKE, B.C.—The Western Canada Power Co. have a large gang of men employed on the construction of the power plant and lines leading to it.

TORONTO.—The Electric Light Co. have made the following proposal to the city, in the utilization by the city of Hydro-Electric power: The city shall have the joint use of the company's poles and conduits at a rental that will meet the interest, maintenance and depreciation of the poles and conduits. The city may take over the lighting of the streets and civic property irrespective of any contract with the company. The city and company are to supply each other with electric energy in case of emergency at a rate to be agreed upon.

WINDSOR.—The citizens by a vote of 622 to 620 decided to allow the Electric Distributing Co. franchise.

New Companies.

Taylor & Arnold, Montreal: capital, \$50,000; to manufacture and deal in iron, steel, metals, rails, machinery, tools and locomotives. Incorporation...

MALLEABLE IRON CASTINGS

PRATT & LETCHWORTH CO.
BRANTFORD ONTARIO

ALUMINIUM

"The 20th Century Metal"

You can

now get your Aluminium requirements

promptly attended to by our clients,

The British Aluminium Co., Limited, of

London, the largest producers in the United Kingdom.

**INGOTS, BARS,
SHEETS, RODS,
ANGLES, ALLOYS,
NOTCHED BARS,
CORNICES, WIRE,
CHANNELS, ETC.**

Sole Agents for Canada: Parke & Leith, 205 Yonge Street (Bank of Toronto Building) - - - Toronto.

Lightest and most adaptable of the industrial metals. Fills a hundred purposes where the ordinary metal fail. Saves its cost over and over again by its lightness and easy working qualities

To-day get Bulletin "D" on the varied uses of ALUMINIUM (Parke & Leith)

JESSOP'S BEST TOOL STEEL "ARK" High-Speed Steel

THE FAVORITE BRANDS WITH USERS OF GOOD STEEL.
A LARGE ASSORTMENT OF SIZES IN STOCK.
JESSOP'S HIGH-GRADE FILES AND RASPS.

80 Bay, St., Toronto, Ontario
Chas. L. Bailey, Agent.

Jas. Robertson Co., Ltd
Montreal, Quebec

Reid-Newfoundland Company
St. John's, Newfoundland.

Jas. Robertson Co., Ltd.,
St. John, New Brunswick

WM. JESSOP & SONS, Limited, Manufactory, SHEFFIELD, ENGLAND.

You've got to use crucibles; are you sure you are using the best? Do you know you could increase efficiency in your foundry?

DIXON'S CRUCIBLES

have been standard for over eighty years. Think a moment what your fifteen or twenty-five years of experience means to you—and we've had eighty years of crucible making. Doesn't this justify at least a trial?

WRITE OUR CRUCIBLE DEPARTMENT.

JOSEPH DIXON CRUCIBLE COMPANY

JERSEY CITY, N.J.

THE BEYER WATCHMAN'S PORTABLE CLOCK



IS TAMPER PROOF
and thoroughly reliable

Shall we send
Particulars?

G. C. BREDIN, Sales Agent
252 Dundas St. London, Canada
Record Dials furnished for all machines.

Do Your Tumbling

in a Globe improved Tilting Tumbler and get finest results, quickest and cheapest. It is made in six sizes for all purposes for wet or dry work.

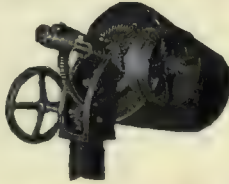

"GLOBE"

Dies and Stampings.
Special Manufacturing
Contract Work.

If you want to get an interesting little magazine free, ask for "THE SILVER PARTNER."

THE GLOBE MACHINE & STAMPING CO.

309 Hamilton Street, Cleveland, O.

Canadian Agent:

H. W. PETRIE, Front St. W., Toronto, Canada

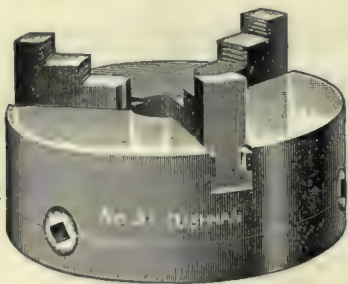

"CUSHMAN" CHUCKS

For general machinists' use.
Strong and durable and
designed for hard service.

Our catalogue shows many
styles and sizes and is sent
free.

The Cushman Chuck Co.

Hartford, Conn., U.S.A.

Established 1892

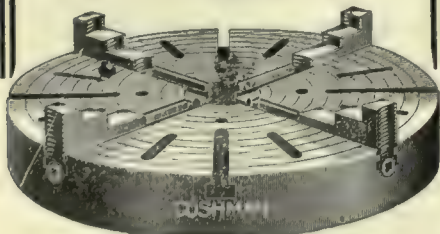

porators, J. Taylor, T. Arnold, both of the City of Westmount, and L. S. Rough, St. Lambert, Que.

Modern Canner Co., Toronto; capital, \$40,000; to manufacture and deal in canning machinery and canning supplies of all kinds. Incorporators, W. J. Taylor, E. Barber and W. J. Thomson, Toronto.

Utilities, Ltd., Montreal; capital, \$50,000; to carry on the business of contractors, engineers, machinists and foundry men. Incorporators, J. A. A. Williams, G. A. Gillies, M. A. Williams, Montreal.

Waterproof Products, Montreal; capital, \$250,000; to carry on the business of miners, refiners, iron founders, masters and engineers. Incorporators, J. J. Robson, J. H. Brittle, C. R. Hazen, Montreal.

National Fire-proofing Co., of Canada, Toronto; capital, \$1,000,000; to manufacture and deal in building and fire-proofing materials. Incorporators, G. G. Paulin, F. G. Waters, F. Armstrong, Toronto.

The Canadian Hardwood Co., Toronto; capital \$490,000; to manufacture and deal in wagons and vehicles of all kinds, as well as hardware. Incorporators, S. Johnston, R. H. Permenter, A. J. Thomson, Toronto.

Western Canada Electric Co., Montreal; capital \$1,500,000; to carry on the business of an electric light, heat and power company in all its branches. Incorporators, G. V. Cousins, P. F. Brown, W. R. Ford, Montreal.

Automatic Cashier Machine Co., Winnipeg; capital, \$100,000; to manufacture and deal in automatic cashier machines and money changing devices. Incorporators, W. H. Brace, J. F. Morrison, S. J. Rebstock, Buffalo, N. Y.

The Halton Telephone Co., Hornby, Ont.; capital, \$10,000; to carry on the general business of a telephone company. Incorporators, H. E. Tuck, Township of Esqueving, G. A. Kennedy, A. Porter, J. Featherston, Township of Trafalgar.

J. O. Gareau, Ltd., Montreal; capital, \$200,000; to manufacture and generate electricity and electric currents for lighting, heating and power to generate steam and gas. Incorporators, J. O. Gareau, A. Lacoste and P. Durocher, Montreal.

Union Special Machine Co., incorporated under the laws of the State of Illinois, U.S.A. have been authorized by the Province of Ontario to manufacture and deal in machinery, tools, goods and merchandise. M. McNeil, Toronto, has been appointed to be its attorney.

The National Brass Mfg. Co., Montreal; capital, \$50,000; to manufacture and deal in metal goods in all their forms, to own and operate a foundry or foundries for the heating, mixing melting and casting of brass and other metals. Incorporators, R. T. Heneker, A. H. Duff and W. S. Johnson, Montreal.

G. B. Prowse Range Co., Montreal; capital, \$50,000; to purchase the business formerly carried on by the late G. B. Prowse, of Montreal; to manufacture and deal in furnaces, ranges, refrigerators, all kinds of hardware, machinery, plumbers' and steamfitters' supplies, paints and oils. Incorporators, C. C. Prowse, W. P. McVey and A. Mallette, Montreal.

Planing Mill News.

COBourg.—Mr. Bull's sawmill at Skibberean about 12 miles from here was totally destroyed by fire on June 16.

CRANBROOK, B.C.—The Cranbrook (B.C.) Sash & Door Co. are enlarging their plant, having contracted for the entire output of two mills.

LETHBRIDGE.—Cushing Bros. Co. will erect a sash and door factory here.

REDCLIFFE, ALTA.—N. H. Bolton, of Minneapolis, will build a sash and door factory at this place.

ST. JOHN.—H. Estabrooks, tea merchant; Alexander Wilson, lumber merchant; Stanley E. Elkin, of the Maritime Nail Works, and W.

SPECIAL MACHINERY, Etc.

ARMSTRONG BROS.

16 Sheppard St., Toronto
Mfrs. of SPECIAL MACHINERY
Patents Perfected
GEAR CUTTING, TOOLS, DIES, ETC.
Ruching and Pleating Machinery.

ERNEST SCOTT

91 BLEURY ST., - MONTREAL

Machinist and Tool-maker
Dies for sheet metal work. Stampings and light manufacturing. Special machinery designed and made to order.

The PARMENTER BULLOCH CO., Ltd. GANANOQUE, ONT.

Iron and Copper Rivets, Iron and Copper Burrs Bifurcated and Tubular Rivets, Wire Nails, Copper and Steel Boat and Canoe Nails, Escutcheon Pins, Leather Shoe and Overshoe Buckles, Felloe Plates.

OWEN SOUND IRON WORKS, LIMITED

OWEN SOUND, ONT.

Cement Mill Machinery, Boiler and Steel Tank Work of all kinds, Grey Iron and Brass Castings

PATTERNS AND MODELS

PATTERNS IN WOOD

~ ALL KINDS ~

Difficult Core Work a Specialty
High Grade - Right Prices - Prompt Delivery
SATISFACTORY WORK GUARANTEED

THE HAMILTON PATTERN WORKS
258 CATHERINE STREET NORTH
HAMILTON, ONT.

PATTERNS

Patterns and Models All work guaranteed.
of any design. Correspondence Solicited.

JAMES SIBLEY

Mechanical Draughtsman and Patternmaker.
156 DUKE STREET, TORONTO
Phone Main, 5747.

YOUNG machinist or technical graduate wanted to travel. Must be good talker and resourceful. No previous traveling experience necessary. Splendid opportunity for ambitious man to work into a good position. Apply

BOX 101
Canadian Machinery
Toronto

ONE MAN can cut threads on 6-in. pipe with a "BEAVER" ADJUSTABLE DIE STOCK



No. 6, threading 1-4, 3-8, 1-2, 3-4 in. complete.
No changing of Dies or Bushings.

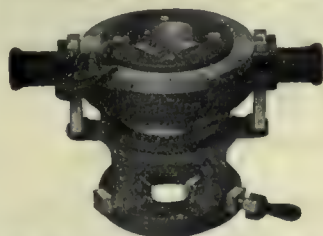

No. 25B, 1 in. to 2 in., R.H. complete.



No. 60, cuts 2½, 3, 3½, 4, 4½, 5, and 6 inch pipe

NOTE—That with the three tools shown above you can thread from 1-4 in. to 6 in. pipe. No loose parts.



No. 41, cuts 2½, 3, 3½ and 4 in. pipe.



"WARREN" DIE STOCK
(Non-receding dies - adjustable.)
Each stock cuts two sizes. Made in four sizes
Prices \$5.00, \$5.50, \$6.00 and \$7.00.

THEY SAVE TIME AND MONEY
Write for our Illustrated List

Borden-Canadian Co.
Richmond St. East, Toronto, Ont.

I. Fenton, insurance manager, are applying for incorporation as the Wilson Box Co., to carry on the manufacture of wooden boxes, barrels, etc., in Milford, St. John county. The capital stock of the company is \$50,000.

SOUTH MAITLAND, N.S.—The mills of the Anthony Lumber Co. were destroyed by fire last month. Total loss, \$90,000.

TORONTO.—Scholey Bros., lumber and planing, was gutted by fire early in June.

General Manufacturing News.

ALBERNI, B. C.—The Barclay Sound Cedar Co. will build a large timber mill at this place.

CHATHAM.—Win. Gray & Sons have purchased the property latterly occupied by the Modern Malleable Range Co. The Gray company will carry on the manufacture of automobile bodies and tops in the new premises.

LONDON.—The London Concrete Machinery Co. will enlarge their plant.

LONDON.—A factory to manufacture automobile bodies and assemble the parts is under consideration by Fred. Mitchell, who has a garage here.

MONTREAL.—The Holland Varnish Co. are erecting a factory here to cost \$20,000.

MONTREAL.—The Kingsbury Footwear Co. will erect a factory double the proportion of their present plant.

MONTREAL.—The merger of five large rubber companies is announced—the Walpole Rubber Company, of Granby, Quebec, the Massachusetts Chemical Co., the Walpole Shoe Supply Works, and the Walpole Varnish Works, Walpole, and the Valveless Inner Tube Co., of New York.

NEW WESTMINSTER.—The National Paper Mills, of Vancouver, purpose erecting a plant near here for the manufacture of pulp and paper.

OWEN SOUND.—A syndicate of English capitalists will construct a million dollar shipbuilding and repair plant and two dry docks at this place.

OTTAWA.—The National Bag and Paper Co. will build a factory here capable of turning out 1,000,000 paper bags daily. Work on the new factory will be started at once.

PARIS, ONT.—Tate Bros., have secured the contract for the big \$50,000 extension to the Penman mills at this place.

PORT COLBORNE.—David Dick & Sons, of Welland, have the contract for building the International Cork Factory to be erected here. Cost about \$40,000.

VANCOUVER.—A permit has been issued for the erection of the plant for the Pacific Pressed Brick Co., at a cost of \$70,000.

VICTORIA.—The Warwick Asphalt Pavement Co. will erect a plant at this place, to cost \$40,000.

VANCOUVER.—The Stegar Silica Brick Co. will build a large plant here.

VANCOUVER.—Col. W. B. Dickey will build a \$70,000 brick plant here.

WELLAND.—The Canadian New Way Motor Co. will locate here. This company is a branch of the New Way Motor Co., of Lansing, Mich. It will manufacture air-cooled gas and gasoline engines, and will employ one hundred men.

Canadian Plant for Michigan Stamping Company.

Articles of incorporation have been filed for a new company to be known as the Dominion Stamping Co., with an authorized capital of \$100,000 of which \$60,000 has been paid in.

It is the intention of the company to purchase a large tract in Walkerville, Ont., and erect a substantial brick factory building in which they intend to manufacture general automobile stampings, including hoods, tanks, fenders, etc., also a large line of stove parts as well as cater to general stamping and machine work.

The principal stock holders are:—Henry P. Cope, John H. French, Geo. S. French, Fred.

A Constant-Speed Drive

A fundamental underlying principle of a constant-speed drive and the mechanically obtained speed changes incident thereto is convenience.

Any machine so designed as to entail the absolute stoppage of the driving pulley, as well as the machine in order to change speeds by the shifting of a tumbler gear or engagement of a positive clutch does not in any way meet the requirements of the case.

Friction back gears are, comparatively, an advantage, but the quick change so obtained is too great. Quick speed changes should have but a slight increment from one to another, in order that the surface speed of the work may be readily and properly accommodated to the capacity of the cutting tool.

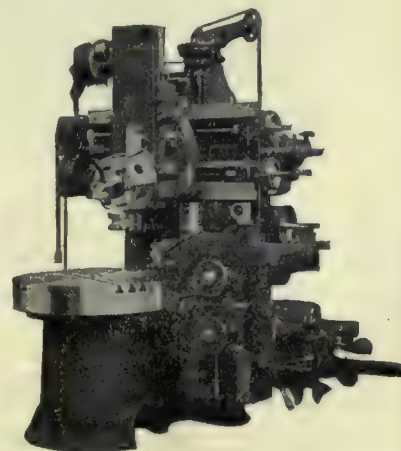

A perfect constant-speed drive is one of the many features incorporated in the VERTICAL TURRET LATHE which tend to make it such a remarkable machine for rapid production of absolutely perfect work.

This feature is only one of the many incorporated in the VERTICAL TURRET LATHE which is fully illustrated in catalog C-15, which is free for the asking.

The Bullard Machine Tool Co.
Bridgeport, Conn., U.S.A.

J. Armstrong, Peter B. Luyster, Milton T. Watson, Robert Houghton and Walter F. Tant, all of Detroit; Benj. W. Valet, of Ironwood, Mich.; and Chas. J. Albert Montreuil, of Walkerville.

Reid Co., St. John's, Newfoundland.

The Reid Co., St. Johns, Newfoundland, are planning to erect a commodious and up-to-date foundry and machine shop in connection with their dry docks and works. The new building will be fitted with the most modern machine tools and machine shop foundry equipment.

Up to the present the company have not been making their own castings but they intend going extensively into that line and build engines and cars for their railroad. The Reid drydock is 640 feet long and here the company's fleet is kept in repair. Reid steamships ply along the Labrador and Newfoundland coast and they have also a line running to Sidney, N.S.—D.W.

G. T. R. Order Equipment.

In addition to the 1,000 steel frame box cars, 500 automobile cars and 10 passenger engines, the G.T.R. has placed orders for \$2,000,000 worth of equipment. Included in the new order, are 15 Richmond freight engines, 25 mogul locomotives, 1,000 hopper bottom coal cars and 500 steel frame freight cars. The order for cars, has been placed with the Canada Car Co., Montreal, Sillker Car Co., Halifax, and G.T.R. shops, Point St. Charles.

Machine Tools for C. N. R.

The Canadian Northern Railway, Winnipeg, are in the market for a list of tools as follows: One 6-foot radial drill. Three 30-inch upright drill presses. One 250-ton 42-inch car wheel hydraulic press. One 24-inch by 12-foot double back geared engine lathe.

One 30-inch by 14-foot double back geared engine lathe.

One 30-inch turret head vertical boring mill.

Three 10-inch screw cutting bolt lathes.

One Rockover grate molding machine.

One power hack saw.

Three emery wheel stands.

One oil flanging furnace for handling boiler plates.

One 14-inch upright slotting machine.

One 18-inch brass finishers' lathe.

One 42-inch car wheel boring machine.

One 36-inch by 36-inch by 10-foot double head iron planer.

One punch and shears.

One 800 pound steam hammer.

One 1-inch to 4-inch pipe threading machine.

One set of plate rolls.

One 24-inch by 12-foot engine lathe.

One 24-inch upright iron shaper.

One 24-inch by 36-inch by 14-foot gas engine lathe.

BROWNING

CRANES
BUCKETS
MAGNETS
SHOVELS, Etc.



At a large manufacturing plant of any kind, one of these machines can be used with profit for handling coal and other loose material, and or doing all necessary lifting and hauling in the yard.

Let us send you Bulletin with full information.

The Browning Engineering Co.
Cleveland, Ohio

MACHINERY SALESMAN

WANTED

Experienced machinery salesman wanted for the Province of Ontario. A technical graduate or man with thorough technical training preferred. Good salary to right man. State age, experience, etc. Applications will be considered confidential.

BOX 252,

CANADIAN MACHINERY

TORONTO

NORTHERN CRANES

All kinds of Cranes—
Hand and Electric
Foundry Equipment
The Newton Cupola.
Catalogue Free

Northern Engineering Works

16 Chene St., Detroit, Mich.

Advance Machine Works, Limited, Walkerville, Ont.,
Manufacturers for Canada.



High Grade Malleable Castings

of all sizes and kinds

Galt Malleable Iron Co., Limited - Galt, Ontario



Cleveland Technical School

By J. A. Webster, B.S.*

IN the erection of the new Technical High School, and in the working out of a co-related curriculum, technic supplemented with the academic. Cleveland has set the pace so to speak, and many of the other larger cities are making haste and falling into line.

The Cleveland Technical High School is unlike any technical or manual training school, institute, or college in the country. The technical work is made the more prominent feature and this is supplemented or co-related with the academic in such a way that the latter is made to strengthen and assist the technical. Mechanical drawing and mathematics are expressed in practical applications by constructing tools and articles in the machine shop or pattern-making department; freehand drawing finds expression in its forms, designs, and outlines in the pottery, printing, millinery or dressmaking departments; applied chemistry experiments in food adulterations, etc., lends interest and instruction in the departments of cooking. Thus it will be seen how the hand and head are educated, one in sympathy and harmony with the other.

New York City has a boy's technical school, the Stuyvesant, and means have been appropriated for a girls' school to be known as the Washington Irving. Newark, N.J., is erecting two technical schools, each costing \$600,000. Chicago is planning to build three or more; Buffalo, N.Y., has decided to spend \$600,000 for a technical school, and Cincinnati has appropriated a like amount for

similar purposes. Grand Rapids, Mich., will build a \$250,000 technical school, while St. Louis has just erected a \$500,000 building, and St. Paul is soon to have a fine new public edifice for this line of education.

Scarcely a day passes that the board of education, or Principal Jas. F. Barker of the Cleveland Technical High School, does not receive inquiries as to the course of study or the educational requirements of this new high school, and many national educators and committees from schools, colleges, and boards of education have visited the school during the past three months. At least 25,000 persons have passed through the rooms and shops, and this number is being rapidly increased daily.

The United States has been a little tardy in accepting this natural means of imparting knowledge. We find that England, France and Germany lead all other nations in providing a technical education for citizenship. For a score or more years Germany has taught manual training in her public schools, and to-day Japan has over 1,600 schools, public and private, which furnish a technical education to her citizens, although she has to send to the United States for much of the machinery used in her schools.

During the past quarter of a century the public schools of the United States, and, in fact, nearly all of the schools and colleges of the country, have offered instruction that was really helpful in a practical sense to only about ten per cent. of those who most needed it.

There are in the academic positions, professors, teachers, lawyers, doctors,

ministers, etc., about ten per cent. of the working population in our civilization. This leaves ninety per cent. laborers, who either had to go without a practical education or had to prepare themselves with the same kind of an education offered the professions. Again we find about four per cent. of our active population employed in the professional and official life, leaving ninety-six per cent. employed in industry and commerce, yet the education of the past has been conserved to the larger benefit of the four per cent.

Broad Education.

In this practical age we have outgrown the antiquated notion that education is only of the head, for the head, and by the head, just as a few decades ago it was discovered that something more than the three r's was needed to round out one's education. We have been tardy in learning that there must be an end to this fatal lack of direction in education. In combining the three h's, head, heart and hand, we are going to discover the manly man in the lad and the worthy woman in the lass.

There is no greater tragedy than the wilful or ignorant wasting of the youth. With all our twentieth century education, with our pomp of material progress and intellectual refinement, we have only learned the first lesson of how to save the child into usefulness, happiness and refinement.

In a technical education all are taught the rudiments of language, arithmetic, geography, science, writing and history. In connection with this academic training such boys and girls who wish to learn some special work into which in-

* Department of Printing, Cleveland Technical School.

clination and aptitude directs, or through the direction of wise parents, are given ample opportunity by competent instructors, with the use of the latest applied machinery and instruments available.

Mind and hand are alternately called into activity in a way that relieves much



Running a Milling Machine at Cleveland Technical School.

of the fatigue and strain of ordinary school work, while at the same time the work of each supplements and mutually illustrates and strengthens the other. What is learned in the recitation room is applied in the shop or laboratory; theories are put into practice, ideas are wrought into tangible form, and labor in turn, when shown in its relations to human thought and history and art, becomes transformed into a most noble and fascinating thing.

This combination of the academic and technic does not mean the gross materialism of education. It means rather the union of the real with the ideal, and that all the varied human likes and loves shall have their natural expression. Professors and scholars will not be exterminated because we educate and train carpenters, nor philosophers become extinct because we teach men to become skilled mechanics. With better machinists, and more efficient carpenters will dawn a new optimism to philosophy and a truer basis to scholasticism, and we will have learned and acknowledged the fundamental truth of civilization, that the first duty of a useful citizen is to earn an honest living.

A glance at a few statistics taken in Cleveland and throughout the State of Ohio (and these statistics compared to other states and large cities, will be found conservative) show the lack of

our educational system during the past, as well as illustrates the present needs of a newer and larger curriculum.

At present there are 128,043 children of school age in Cleveland. Of these 90,673 are under sixteen years of age, and 41,206 not in any school. Most of these are over sixteen years of age.

In 1906 2,447 children dropped out of school between the sixth and eighth grades. In 1908 3,144 dropped out, and in 1907 2,925 dropped out. Thus 8,916 children dropped out of school at this critical age in the last three years into unskilled labor.

In round numbers there are 30,000 children in Cleveland between the ages of sixteen and twenty-one who are earning their living without any special preparation and there are at least 10,000 children between the ages of fourteen and sixteen who are helping to earn a living without an education of any special preparation.

Out of the 460 factories written in Ohio, but 61 have some sort of apprenticeship for its employes, and only one turns out machinists to fill a great and growing want. The wave of popular thought that is spreading over the whole nation shows that a change in our system of education is demanded and that our boards of education are meeting this demand. Cleveland has been foremost, and through her progressive board of education and an able corps of instructors is fast working out a text of technic and academic instruction that will appeal to the needs of the day.

Cleveland Technical School.

The Cleveland Technical High School owes its origin to the board of education of 1906. In his inaugural address at that time, the president, Mr. Samuel Orth, said: "Industrial education as carried out by the manual training department of the high schools was wholly inadequate; that this manual training was entirely secondary; and that though it aimed at adaptness, it was not of such a nature as fitted for an occupation." An educational commission reported favorably to the establishment of a manual training high school in September, the same year, and on March 5, 1906, the board unanimously adopted a resolution authorizing the issue of bonds for the purpose of erecting such a school.

Active operation began on the building August 30, 1907, and the school was opened for enrollment of pupils and the organization of classes October 6, 1908, and one week later, regular class work began in all departments, with an attendance of over seven hundred pupils. Of this number only forty-seven came from other high schools in the city, thus verifying the prediction that the school would create its own field in a high

school population whose want had hitherto been unmet.

The style of the building is English Gothic. It is a dark reddish brown superstructure with terra cotta trimming, and rests upon a heavy stone water table which gives an effect of strength and massiveness well calculated to offset the usual amount of wall space sacrificed to ample lighting. Upon entering the building from the main entrance there is a large reception room at the right, while at the left are the offices. Directly opposite the entrance across the main corridor, which connects the north and south wings, is the spacious auditorium, with a seating capacity of nearly four hundred. The lecture rooms and laboratories for physics and chemistry are at each end of the main building. In the north wing the entire area is devoted to a lunch room, with large kitchen and serving rooms. The main dining room for pupils seats about 300, and a smaller room for teachers accommodates about 25, where noon-day lunch is served at nominal cost.

The entire south wing basement, as well as the first floor, is occupied by the shops. The pottery department is well equipped with potter's wheels, lathes for turning models, a slip house and a glass room set, kilns, cabinets, etc. Adjacent to this is the forge shop, with provisions for a blacksmith class of 36. The forges have down draft and the



Running a Lathe at Cleveland Technical School.

entire equipment is thoroughly modern. The next room is the machine shop with heavy machines suitable for the very best of trade instruction. At the end of the corridor is a foundry with a cupola for the melting of iron, a brass furnace, suitable core ovens, etc. At

the extreme rear of the building the heating and power plant is installed. This furnishes heat, ventilation, electric light and power and has a capacity of over four hundred horse-power.

On the first floor of the main building at the front corners are two large

women already engaged in a vocation to better their condition by increasing their technical knowledge and skill.

In most classes the nature of the studies and the purposes in view are so different as to demand a separation of the boys and girls. There is, therefore,

As mechanical drawing is made the medium of expression in the shop, so is freehand drawing in the department of applied arts. Nature forms are studied and sketched in the flat, in detail and in color. Then they apply in constructive work, as in borders for garments, draperies, naperies, and in embroideries, in the decoration and making of utensils and articles of household and personal use from various materials and fabrics.

The course of domestic art includes plain sewing, the making of outfits for use in the departments of domestic science and domestic art, undergarments, shirt waist suits, simple summer dresses and millinery. Principles of handwork in the way of rolled edges, setting of lace, handrun tucks and elementary embroidery are introduced and applied to underwear. Original designs made by the pupils are used for this work, and in the decoration of the table linen for the dining rooms of the domestic science department.

The purposes of the work in the domestic science department is threefold: (1) To teach all subjects pertaining to the care and duties of the home. (2) To teach all theory relating to the above subject as applied science, that girls may acquire intellectual development as well as practical skill. (3) To teach institutional cooking and kitchen management as trade subjects, that students may be prepared for catering as a vocation. The lunch room in connection with the school affords excellent opportunity for girls desiring to specialize in institutional cooking. After having learned the fundamental principles the student may go into the kitchen or the lunch room and prepare foods in larger quantities.

rooms, with seating capacity of two hundred and fifty reserved as study halls, one for boys and one for girls. In the wing above the shops are five wood-working shops, including joinery, turning, cabinet-making and pattern-making shops and a room for re-sawing and storing stock. In addition to the usual hand tools in these rooms, suitable wood-working machinery has been installed to meet the requirements of modern methods of manufacture. Opposite the entrance to this corridor is a drafting room for the preparation of designs for school problems. There is also a room for varnishing and finishing woodwork.

The second floor is devoted to recitation rooms, the school library and mechanical drawing rooms.

The third floor, north wing, is entirely devoted to the girls' departments. Here are located the kitchen for instruction in cooking, the dining rooms for lessons in table service, and the laundry. Rooms for instruction in plain sewing, dress-making and millinery are situated in the corner of the building. Additional mechanical drawing and freehand drawing, applied art and recitation rooms, a clubroom for school organizations and a rest room occupy the remaining floor space.

The fourth floor is occupied by additional rooms of the department of applied arts and by the printing department.

Objects in View.

The Cleveland Technical High School has two immediate ends in view: (1) To prepare youths of both sexes for a definite vocation and for efficient industrial citizenship. (2) To help men and

organized within the one building a boys' school and a girls' school.

The daily session consists of nine periods of 45 minutes each, beginning at 8.25 and ending at 3.25. Ordinarily each student is expected to carry three academic and two technical or laboratory subjects.

The school is in session the year round. The year is divided into four quarters of twelve weeks each, with one vacation week between the quarters.

The subject of mechanical drawing is taught as the language through which the student learns to give graphic expression to ideas which he learns to work out later in material forms in shop and work rooms. It is the one medium through which craftsmen are able to record, clarify, and perfect such ideas as

may come to them. The problems do not only bring into use the various instruments in the student's equipment, but also represent some definite object to be made later in his course in joinery, wood-turning, forging or pattern-making.

Shop work is intended to be educative and creative as well as technically constructive. From elements and principles taught in the mechanical drawing and shop classes each pupil makes his own designs, which he executes from working drawings. Free scope is given to his



Pattern Making, Cleveland Technical School.

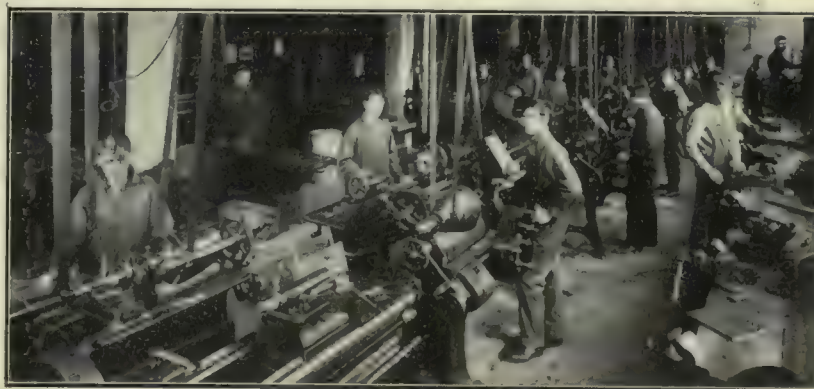

Machine Shop, Cleveland Technical School.

inventive talent in the making of his designs. When the design is decided upon, he is held to strict accuracy and workmanship in its execution.

Specialization.

If after a time a pupil shows peculiar adaptability in any given direction, specialization along this line will be permitted in order that on graduation a pupil may be better fitted for his life work. The choice of a vocation is forced upon our youth at an early age, and if a proper choice can then be made it is a great advantage. After completing two preliminary years in wood and iron working and in mechanical drawing, he may then devote a major part of his last two years to the particular branch along which his ambitions lie.

A course of practical printing is offered as a fourth-year elective. This is utilized in printing official blanks, school catalogues, the school paper, and announcements of the school. Much of the instruction in the various courses of technical work is of so special a character that no suitable text book is yet available. The printing office is therefore brought into frequent requisition for supplying printed copies of the instructor's notes, diagrams and explanatory text to the students.

A periodical, edited and managed by students of the English department is published as the official organ of the school. This is illustrated by students of the drawing departments.

One of the most important missions which this school can fulfill is the betterment of people already engaged in some vocation.

The abolishment of the apprenticeship system in the sub-division of manufacturing processes has made it practically impossible for mechanics to secure any general training which will increase their efficiency and hence their earning power in their present position or enable them to fit themselves for a better position. This school offers trade courses during the evening to men and women who are already employes during the day. The entire equipment used during the day is available for the evening classes.

Instruction is offered in carpentry, cabinet-making, pattern-making, foundry practice, tool forging, sheet metal work, machine shop practice, trade mechanics, applied mechanical, architectural and machine drawing. Complete courses in plain and hand sewing, machine sewing, spring and fall millinery, cooking, freehand drawing, charcoal and water color rendering, clay modeling, bookbinding, printing, leather work and art metal work and designing as applied to the crafts.

MANUFACTURERS AND UNIVERSITIES.

The following suggests a plan whereby Canadian manufacturers may receive a great benefit from Universities.

Prof. Robert Kennedy Duncan, Professor of Industrial Chemistry in the University of Kansas, has announced that three important discoveries have been made by research students in his department. Various manufacturing concerns in the United States have endowed fifteen scholarships, thus furnishing the funds necessary for the experimenting. The companies which give the scholarships have the privilege of indicating the line in which they wish the research work to be done, and are protected by patents for the exclusive right of sale or manufacture of any products or processes resulting from the experiments. The fifteen scholarships have already resulted in three remarkable discoveries, and Prof. Duncan states that a number of other students now engaged in experimental work will undoubtedly accomplish important things.

The most important of the discoveries made probably is in the manufacture of casein. E. L. Tague, a fellow in industrial chemistry, has perfected a process of manufacturing this product from buttermilk, something chemists have been unable to accomplish heretofore.

Buttermilk has always been a waste product. Millions of gallons thrown away by creameries can now be turned into a practical benefit for use in the manufacture of casein, which is extensively used in the sizing of paper by paper mills. It is also used in manufacturing brushes, combs, billiard balls, and many other articles.

Archie Weith and Frank Brock are two other students in the same department who have made discoveries scarcely less important. After working a year and a half these young men have found a way to make an enamel for steel-containing tanks that has the same coefficient of expansion as the steel itself. By the use of their process of manufacture an enamel is obtained that will not crack under conditions of extreme heat or cold. The enamel is also resistant, will flow over the steel properly in the enamelling process, and is resistant to acids. It can be used as a lining for steel tanks and towers in various kinds of industrial occupations.

Two years ago the National Bakers' Association granted a fellowship paying \$500 a year to Henry Krohman to carry on experiments in search of some means of making salt-rising bread uniform in quality.

The efforts of Mr. Krohman also have proven entirely successful. He has dis-

covered a way to isolate the microbe which causes the bread to rise. This means that bakers will be enabled to supply bread of a better quality and lower in price to consumers all over the country.

Prof. Duncan, head of the department of industrial chemistry, is a Canadian, a native of Brantford, and a graduate of the University of Toronto. He is himself the discoverer of a number of industrial processes.

TECHNICAL EDUCATION COMMISSION'S TOUR.

The itinerary of the Technical Education Commission has been completed. The first sittings were held at Halifax, N.S., on July 18, 19 and 20, and others in the Maritime Provinces will be held as follows: Lunenburg, July 22; Liverpool and Yarmouth, 23; Digby, 25; Middleton, 26; Kentville and Wolfville, 27; Windsor, 28; Truro, 29; Sydney and district, August 1, 2 and 3; New Glasgow, 5; Pietou, 6; Charlottetown, 7 and 8; Summerside, 10; Amherst, 12; Shediac, 14; Moncton, 15 and 16; Sussex and Hampton, 17; St. John, 18 and 19; Fredericton, 22; Woodstock, 24.

The commission will then go to the Toronto Exhibition.

The Quebec and Ontario dates are: Quebec, Sept. 13 to 15; Three Rivers, 16; Sorel, 17; St. Hyacinthe, 18; Sherbrooke, 20; Montreal and Valleyfield, 21 to 28; Ottawa and Hull, Sept. 29 to Oct. 3; Lachute, 4; Smith's Falls, 5; Cornwall, 6; Brockville, 7; Kingston, 11; Belleville, 12; Peterboro, 13 and 14; Toronto, 17 to 20; Barrie and Orillia, 21; Hamilton, 24 to 26; St. Catharines, 27; Niagara Falls, 28; Brantford and Paris, Oct. 31 and Nov. 1; Galt, Nov. 2; Berlin and Waterloo, 3 and 4; Guelph, 5 and 7; Stratford, 8; Woodstock, 9; London, 10 and 11; St. Thomas, 14; Chatham, 15; Windsor and Walkerville, 16.

The commission will then go west and stay there till the end of January. On the way back St. Louis, Chicago and Milwaukee will be visited. The commission early in February will go to the eastern United States and then sail for Europe.

In one factory a regular doctor spends eight hours a day at the plant. He has an office completely equipped for immediate relief in any kind of accident.

Invoices for miscellaneous supplies as they come in, are checked with department requisitions for those supplies, entered under department headings in a single loose-leaf book and paid by check on the 26th of each month by the treasurer of a steel-casting company. He saves clerical work and forms.

Tempering Carbon Steel Gears by "Local" Hardening

A Description of Equipment Necessary and the Various Operations in the Process—This is Known in Sheffield as "Local" Hardening.

By FRANK WALKER.

In tempering gearing it must be clearly borne in mind that only the teeth require to be hardened, the other parts of the wheel or rack must be kept normal, or better still, be slightly annealed.

The hardness of the teeth must be absolutely uniform and must be accompanied by the highest elastic limit obtainable, while cracking or shelling must be entirely avoided.

Perfection can only be attained by a thoroughly efficient equipment, operated by an equally efficient staff, and the strictest attention to details. There must be no "near enough" about it, "absolute in everything" must be the watchword. If it is found that a certain grade of steel gives the best results when dipped at, say, 1,525 deg. Fah. the greatest care must be taken to always attain this heat—no more and no less.

The Equipment.

I propose first to describe the equipment necessary and then proceed with a description of the operation:—the sizes of the various items being, of course, dependent on those of the articles to be treated; and they should be grouped as closely as convenient on a level, unobstructed, standing.

The best furnace for the work in question is, undoubtedly, the oil-heated oven type, it is self-contained, cheaply operated, and capable of maintaining the highest temperature required under perfect control. It should be provided with a reliable pyrometer as the old method of judging temperatures by color is not to be depended upon. The furnace door should open vertically and should have in its centre a sight-hole fitted with a fire-brick plug.

Experience in this class of work has shown that the cooling medium which gives the best results at one operation is good animal oil—preferably whale—at a temperature of not less than 390 deg. Fah. It should be contained in a wrought-iron tank having a water-jacket extending all around and under the bottom through which cold water must be circulated and the temperature of the oil should not be allowed to rise over 450 deg. Fah. The tank should be sunk in the ground so that its top should project not more than 18 inches above the standing, and should be protected when not in use by a removable cover.

For convenience in charging and drawing expeditiously—and it must be re-

membered that careful haste must be observed in every movement, "Festina lente" is the motto for a tempering plant—it is best to have a small crane erected so as to command the furnace and dipping tank, one of the simplest will suffice, a swinging jib with a runner carrying a set of quick motion chain blocks.

Between the furnace and the dipping tank, and in the crane-path, a substantial platform must be provided, the same height from the standing as the fore-plate or sill of the furnace door, and having underneath it a bin to contain good foundry loam sand.

By the side of the oil tank, placed out of the way, but easily accessible have another bin holding common road sand, for use in case the oil should catch fire, a small blaze always occurs when an article is dipped, but this can be easily checked by agitating the surface of the oil with a rake or paddle, but if the flame gets out of control smother at once with sand.

Charging Lever.

An important tool which will be required is the charging lever, or "peel"; this should be practically the same in form as that used in charging ingots into a reheating furnace, but should be suspended by an eye riveted through it to avoid slipping or canting.

A set of charging plates must also be provided of various diameters, these can be made from old boiler plate $\frac{1}{2}$ in. or $\frac{5}{8}$ in. thick, they will require renewing occasionally as they crack and buckle with the heat.

Have a good supply of lifting tackle, eye-bolts and plates, single, double and triple-legged "ring-and-hook" chains, etc., and see that each one is as light as compatible with the work it has to do.

Great orderliness must prevail, "a place for everything and everything in its place," for remember a red-hot wheel will not hold its heat while operators are stumbling about on a littered standing.

The whole plant should be enclosed in a well-ventilated building with the roof not too low.

Before proceeding to describe the operation, it is necessary to state that no hard and fast rule can be laid down for temperatures, carbon steels vary to such an extent that though an analysis may give approximately the best heats for tempering purposes, it is imperative to make

a series of careful experiments with test pieces to determine exactly the requisite temperature to give the best results and also to determine the fusing point—this is very important, and an exact record should be kept of each experiment and filed for reference.

Description of Process.

To insure success in the process of hardening, every movement must be carefully thought out and every emergency provided for. Provision must first be made for lifting the wheel when heated to convey it to the dipping tank, in the case of small wheels and pinions this may be done by means of an eye-bolt through the hole in the hub, with a plate underneath; with larger wheels it is better to drill three holes in the web, and use three eye-bolts and a "three-leg" ring and hook chain, these holes can be tapped and plugged after the wheel is finished.

Gearing must always be dipped so that the teeth enter the tank uniformly, that is to say, a wheel must be dipped on its flat and not on its edge: bevel wheels must be heated apex upwards and dipped base upwards and provision must be made for turning them over when heated, this is best done with a pair of tongs such as are used by forge-men for handling small billets.

Having fixed the eye-bolts securely in their required positions, take a charging plate a few inches larger in diameter than the wheel and place it on the platform or "making-up table" letting it lie evenly on three or more low stands—half bricks will do—so that the charging peel can be slid underneath it. On this plate place a layer of loam sand two or three inches deep. In the case of a bevel wheel the sand must be deep enough to prevent the eye-bolts from touching the charging plate. Take the wheel to be hardened and press it down on the sand bed, ramming underneath till the sand is packed to the contour of the wheel and well pressed down to the lower edge of the teeth, using a small trowel for this purpose. Bevel off the sand from the lower edge of the teeth to the edge of the charging-plate, then protect the upper surface of the wheel in a similar manner, bringing the sand well up to the edges of the teeth. It is best to use a small firmer for this. It will be seen by this method that only those parts of the

wheel which require to be hardened, namely, the teeth, are exposed to the heat.

The made up wheel or "Pie" is now ready for charging into the heating furnace, which should in the meanwhile, have been raised to and maintained at the exact heat required. The "pie" must be charged by means of the peel and crane, bringing it right up to the fire-plate before raising the furnace door in order to prevent as much as possible the loss of heat. It should be placed in the furnace on stands—small cast iron tripods do very well for this—so that the teeth stand evenly in the heat-zone, and also to allow the peel to be withdrawn and reinserted without disturbance. If the furnace door is not a good fit it is advisable to lute it with a little fire-clay.

The pie must be heated as rapidly as possible and by careful and accurate readings of the pyrometer and frequent inspections through the sight-hole it is possible to determine the exact moment when the requisite heat has been imparted to the teeth, it must then be drawn quickly, placed on the making-up table, the wheel stripped and cleaned of sand, and plunged evenly and steadily into the oil. The chains used for dipping should be sufficiently long to allow the wheel to be suspended by a bar across the edges of the tank and hang mid-way in the depth of the oil.

Two important points must be observed in furnacing. Always draw the pie on a rising heat and do not allow it to "soak" as this is detrimental to successful tempering.

The wheel should be allowed to remain in the oil until its temperature has been reduced to that of the bath, then withdrawn and hung over the surface to drain and then allowed to cool down to atmospheric temperature.

If proper care and attention have been taken it will be found that the teeth will be hard enough to resist a file and elastic enough to stand hammering, while the body of the wheel will have been slightly annealed, the hardness of the teeth graduating back into the softer rim.

In large wheels a certain amount of warping will take place, but they can be brought back to shape by resetting under a hydraulic press or drawing them down by plates and bolts on the plateau of a planer, and it is advisable to leave a finishing cut to be taken off the hub faces, and bore after this is done.

Resetting is best done at a temperature of 225 deg. Fah. Racks may be treated in the same way—they should be

heated teeth upwards and dipped teeth downwards.

The burnt oil may be removed from the faces of the hardened articles by washing with gasoline.

MACHINERY MERGER.

The Canada Machinery Company, Limited, was incorporated under the Canada Companies Act on July 5, 1910, and has acquired the business and undertakings of the following companies:

1. MacGregor, Gourlay & Co., Ltd., Galt, Ont.
2. John Ballantine & Co., Limited, Preston, Ont.
3. Hespeler Machinery Co., Limited, Hespeler, Ont.

And the Woodworking Machinery Departments of:

1. Goldie & McCulloch Co., Limited, Galt, Ont.
2. Sussex Manufacturing Co., Limited, Sussex, N.B.

The companies controlled constitute practically all the concerns in Canada manufacturing the lighter grades of woodworking machinery and tools. They also constitute a large percentage of the manufacturing capacity of iron working tools in Canada.

The intention of the company is to perfect the organization of the different factories upon a uniform basis, thereby eliminating the excessive duplication of special machinery, etc., which has taken place in the past.

The reproductive value of the plants, as determined by the Canadian American Appraisal Company is \$1,027,973.33, over two and a half times the present bond issue of the company. The bonds are being issued under a deed of trust and mortgage by the company to the Montreal Trust Company, of Montreal, and are secured by a fixed and specific first mortgage and charge upon all present and future real and immovable property of the company.

The total amount of bonds to be issued is limited to \$1,000,000, and can only be issued up to 66 2-3 per cent. of the appraised value of the affixed assets. Of this sum \$400,000 has been issued and is now being issued. The remaining \$600,000 can only be issued to an amount equal to 66 2-3 per cent. of expenditures on capital account subsequent to August 1st, 1910.

On or before the 1st of August, 1914, and annually thereafter, a cash sinking fund of 2 per cent. of all bonds outstanding is to be paid to the Trustees, and used to purchase and retire these bonds at not exceeding 110 per cent. and accrued interest, or to call bonds at that price if not so purchasable. All bonds so purchased shall be the property of the trustee, and the coupons

shall be collected by the trustee and carried at the credit of the sinking fund.

It is estimated that the net earnings of the company for the ensuing year, based on present output, will be \$120,000, showing the bond interest earned five times over. These earnings will be materially increased during the following years. The auditors' reports of the various factories have not as yet been completed, but the audit of one of the principal companies shows average net earnings for the years 1900 to 1910 of far more than the amount required to pay the interest on the entire issue of \$400,000 bonds. Mr. George D. Forbes, the President of the company, in a report, says the benefits to be accrued from the consolidation may be summarized as follows:

Increased efficiency, resulting in economy by specializing the output at the different factories and by eliminating the unnecessary duplication both in output and patterns.

Savings to be effected in the purchase of raw material and in administration.

Economies in selling, distributing, manufacturing, and transportation charges.

The consolidation is being effected just at a time when the industry is showing tremendous development, and the new company, by placing the different factories on a uniform basis will be in a position to take full advantage of it.

The directors are as follows: Geo. D. Forbes, Esq., president; President, R. Forbes Co., Ltd., Hespeler, and Taylor Forbes Co., Ltd., Guelph. R. O. McCulloch, Esq., vice-president, Goldie & McCulloch, Co., Ltd., Galt; R. MacGregor, Sr., Esq., vice-president, president MacGregor, Gourlay Co., Ltd., Galt, Ont.; S. H. White, Esq., vice-president, president Sussex Mfg. Co. Ltd., Sussex, N.B., and New Brunswick Telephone Co., Ltd.; Thos. H. Watson, Esq., Toronto, Ont., vice-pres. and Gen. Mgr. Canada Bolt & Nut Co., Ltd.; Alex. G. Gourlay, Esq., Galt, Ont., MacGregor, Gourlay Co., Ltd.; Garnet P. Grant, Esq., Montreal, Pres. Dominion Cannery, Ltd., vice-Pres. Canada Bolt and Nut Co., Ltd.; Harry Cockshutt, Esq., Man. Dir. Cockshutt Plow Co., Ltd., Brantford, Ont.

The manager of a woodworking mill on going over his cost sheets discovered that increases in the cost of the item of "blown fuses" matched the decreased output from a certain group of electrically-driven machinery. His cost system suggested the addition of a special protective device—an automatic circuit breaker.

Mechanical Features of the Cummer Asphalt Plant

A Machine which Exemplifies what Can be Done by the Designer where Space is Limited--General Description of the Arrangement of the Parts.

An unusual piece of machinery has just been completed at the works of the John Inglis Co., Toronto. It is an asphalt plant built from designs furnished by the Cummer Co., Cleveland, for a Winnipeg paving contractor.

From a mechanical viewpoint, it presents many interesting features, notably the compactness, and economical utilization of all available space, at the same time not neglecting utility and ease of operation.

As shown from the cuts, the plant is portable, operating from any convenient side-track, adjacent to the work. Two 24 in.—100 No. 1 beams, 65 feet long, each tied by a 3¼-in. truss rod, form the frame structure of the outfit. This frame is carried on two trucks, of one hundred tons capacity each, situated 51 feet centres, necessitating the heavy ties just mentioned. It is necessary to place the trucks this distance apart, for part of the structure extends down through the frame quite close to the rails. The total weight of the machine above the trucks is 140,000 pounds, nearly undistributed throughout the length of the frame.

A bucket chain in the chutes AA raises sand, and drops it through the chute B into a slowly rotating drum under the corrugated casing C. This drum, which slopes slightly toward the far end, to cause the sand to travel in

that direction, has a fire place built beneath it, which is fed through the fire-doors D. Combustion is promoted, and all moisture in the sand drawn off through a pipe F, by the blower G on top of the drum casing. The arrange-

cessary power for all purposes. Steam is generated in a 70 h.p. vertical, enclosed fire-box boiler I.

That power might be transmitted at right angles to rotate the drum without the use of large bevel gears, a Hindley worm gear at J is used. This makes a small compact arrangement, which is completely encased in an oil box. This secondary shaft carries a pinion, which engages the gear on the large drum. Power is also transmitted to the pulley



Cummer Portable Asphalt Plant.

ment is such that the hottest blast strikes the driest sand. The drum revolves on the rollers E at the near end, and in a special adjustable trunnion at the far end.

A 50 h.p. engine, H, completely encased to be grit proof, supplied the ne-

K on a central shaft which in turn drives the blower by a belt, and the mixer and elevator, referred to later.

The sand after its passage through the revolving drum, falls into the transverse passage L, and thence into the bottom of the vertical elevator M, which



Cummer Portable Asphalt Plant



Cummer Portable Asphalt Plant

carries it by a bucket conveyor to the storage tank N, where it can be released as desired through a gate O.

The asphalt end of the machine consists of three tanks P, Q, R, with a furnace under each.

Q and R are open to the atmosphere by loose hinged doors in the top through which they are fed, while the tank P is air tight, and capable of withstanding a slight pressure. It is the final tank taking its supply in liquid form from either Q or R. To fill P, a vacuum is created therein, by the Westinghouse air pump shown, which draws the liquid into P. At the proper moment, the suction valve can be closed and pressure created in P by the pump, forcing the liquid out into the mixing chamber, the amount of discharge being regulated by a valve.

The mixing chamber S, is open and consists of a cast iron shell in which are two sets of intermeshing paddles. These thoroughly mix the two substances—sand and asphalt. The mixer is driven from the previously mentioned central shaft through the gears T and U. The elevator is driven from the same source. A valve beneath the mixing chamber discharges the mixture into a wagon beneath.

All the outlying superstructure may be readily removed for transportation making the shipping dimensions 65 ft. long, 10 ft. 2 in. wide, and 14 ft. 2 in. high. All these removable parts are made in small sections to facilitate field erection. The small jib crane V, assists.

As a mechanical contrivance, it forms a remarkably compact arrangement, and shows what can be done by the designer where space is limited.

METAL DRAWING IN CANADA.

By Geo. Koff.

The development of the art of drawing and stamping metal has been exceedingly rapid of late. The press builders have kept pace with the fast increasing knowledge of the physical properties of the various metals, especially as to their flow. New steels have entered into the progress of art, not only in the product itself, but also in the tools used in its working. One after another, obstacles have been overcome which have hitherto been considered insurmountable. The press designers are turning out machines to do work which had been supposed to be impossible for accomplishment. Precision work, involving the manufacturing of parts in which the limit of variations is a small fraction of a thousandth of an inch, is now being carried on commercially quite as a matter of course, with an enormous saving of time and money as compared with what had been practically hand work, and at the same time

with a greater uniformity of product. In automatic press work, marvels of manufacturing have been developed recently. An instance of drawn metal is the manufacture of very long slender tubes of various metals, closed at one end.

The field of pressed metal has been enlarging ever since its beginning, which has not many years ago, but lately the growth seems to have been given a new impetus, doubtless because the knowledge of the various elements that enter into the art has been more nearly perfected. The efforts of research by many experts have been brought to fulfillment, furnishing more exact data as to details of the properties of metal, with important results in the design of the machines and tools with which it is worked. Beneath all, is the basis of the experience of many practical men. The pressed metal people have always held that their branch of industry was only at the threshold of its usefulness, and this would seem to be a better grounded prophecy to-day than ever before, because its foundation in fact is the more apparent.

The first drawn work was done to supply a demand for seamless parts to replace castings, which were too heavy and cumbersome for convenience or appearance. Ferrules for various purposes, stove knobs and a few other specialties were produced and sold at a great margin of profit, because at even high prices as compared with their cost the expense to the purchaser was little if any more than under old methods, and the drawn metal was greatly superior for the purpose. From the small beginning the business progressed rapidly. The possibilities of its application were seen, and as time went on many manufacturers entered the field. Finally general manufacturing companies established departments for the manufacture of metal parts of their products, or the cans and metal boxes, in which to pack them.

With competition came the spur to better and cheaper methods of production, and in this the press builders have played the most important part. The development has included greater power, greater speed of production, greater precision, automatic feeds, combinations of processes in one machine and special machines of wonderful ingenuity, with principles of design conforming to the knowledge gained by the experience of the pressed steel manufacturers and the investigations of their experts, and by the manufacturers of the metals which are used as tools and as raw materials for manufacture. The adaptation of the products has been so broad as to be revolutionary. There are few articles in which metal plays a part to which the press does not contribute its

share, as a rule improving the quality and lessening the cost. Other branches of mechanics have entered into the work, especially important being the new welding processes, notably the electric and the oxy-acetylene, both of which produce results previously impossible, and consequently adding their important functions in developing the field.

There are instances of manufacturers or those who would be manufacturers who have abandoned ideas because the special machinery people in the past have been unable to give them the equipment with which to manufacture cheaply by automatic processes. To-day these machines could be furnished in many cases. Manufacturing has been simplified by the reductions of the number of operations necessary to accomplish a certain work, which constitutes a very great development in pressed metal working. The manufacturer who is equipped with the most modern tools can compete successfully at a satisfactory profit, for what to him is a sufficient price, would be below cost to a competitor less well equipped. Figuring is frequently very close indeed in this line, and as in many other branches of business, first-class machinery is necessary if money is to be made. First-class machinery is particularly noticeable in the manufactories in Canada.

WESTERN DRY DOCK CO.

A large order for machine tools has just been put through at the King Edward Hotel, Toronto, for the Western Dry Docks Co., of Port Arthur, through their agents, Messrs. Fenn, Rankine & Wallace. The order was well distributed among the different manufacturers, as follows:

John Bertram & Sons, Dundas—

- 1 large plate shear.
- 1 bending roll.
- 1 angle shear.
- 1 lathe.
- 1 drill.

London Machine Tool Co., Hamilton—

- 5 60-in. punches.
- 2 48-in. shears.
- 1 large planer.
- 1 lathe.

Canadian Westinghouse Co., Hamilton—

Electrical equipment.

John Inglis Co., Toronto—

Pumping machinery.

Orders for electric cranes were placed through Rudel, Yeates, representing Pawling & Harnischfeger, Milwaukee.

Other smaller contracts were let through different local firms.

Notes on Some British Manufacturing Processes

Pneumatic Plant for Small Tools, Aeroplane Propeller Blades, and the Goff Patent General Wheelwright are Here Fully Described.

By Herbert A. Carter.

Herewith are descriptions of a number of interesting British processes which will, no doubt, be of interest to readers of Canadian Machinery.

Pneumatic Plant for Small Tools.

The pressure of a gas may be raised by simply heating it. The increase in pressure enables the gas to do more work by a given volume charge, hence the advantage of heating compressed air is at once apparent. On compressing air in practice its pressure at once rises, and this by increasing the back pressure increases the work that must be done to effect a given compression. Were there no temperature rise the work done during compression would be less. In practice it is impossible to secure perfectly isothermal compression, though this is approached by repeatedly cooling the air between the various compressor stages. It is also impossible to retain the compressed air that heat so acquired by compression. If the compressed air be used straight from the cylinder without re-heating, none of that part of the work done in compressing it which went to overcome what may be termed "the temperature back pressure" can be recovered. If, however, the air be re-heated by passage through the fuel-heated stacks of metal tubes to, or above, the temperature at which it was fed into the storage cylinder, the source of inefficiency is entirely removed, and owing to the heat supplied being used about five times as efficiently as if used in steam-raising a surprising over-all efficiency of power transmission may be realized. So great is this cooling in many practical ways as to result in the copious formation of hoar frost, on and around the exhaust pipes and ports. Compressed air on expanding is cooled by the inverse action of that by which it was heated in compression. The formation of hoar frost just referred to is advantageous in many ill-ventilated mines and tunnels, but in general it is convenient to avoid such an excessively cold exhaust by re-heating the air before use in the air motor. The latter result, if re-heating, however, is a minor one, the gain in thermic dynamic efficiency being the argument in favor of such treatment. Perfectly adiabatic, or isothermal working being both unattainable in practice, it is unusual in modern compressed air establishments, to approach isothermal compression as nearly as possible by the use of multi-stage compressors with inter-coolers to store the

compressed air in, storage cylinders of suitable capacity and strength, fitted with relief cocks and to re-heat the air just before it passes into the compressed air engine, and even during its utilization in the latter, by the use of hot jackets, or preferably, multi-stage engines with inter-heaters, which are stacks of steam or fuel-heated pipes.

Aeroplane Propeller Blades.

So far as the theory of the propeller is concerned, one made from solid wood would be equally as good as one built up, but when made from solid wood the blade is short-grained and consequently very weak. Unless for a small model a propeller should always be built up. Glue is the substance generally used for sticking the pieces together. When finished the whole should be well varnished to keep the damp out. The following is Sir Hiram Maxim's method. He built them up in the usual way, and when finished they are varnished over on both sides with hot glue. When dry, they are carefully sandpapered, then covered with strong, smooth Irish linen, which is glued on. When this is dry they receive another coat of glue, are again smoothed with sandpaper, and finally they are painted with zinc white in the ordinary way and varnished. The following pitches are taken from practice, and will be a guide. They vary in different machines of the same make:

	Dia. H.M.	Pitch H.M.
Curtis	6.0	6.0
Voison	7.6	4.7
Wright	8.3	9.6

The pitch ratio, which is $\frac{\text{Pitch}}{\text{Dia.}}$ varies

from 0.4 to 1.2 in practice, between these limits, the higher pitch ratio the greater the efficiency,

The Goff Patent Wheelwright.

This is a new machine, which is being made by an Oldham, Lanc., firm for hand, foot or steam power, driving, and they claim that it is the best wheelwright in the world. Its price brings it within the reach of even the smallest users. It is the best and most satisfactory wheelwright ever invented, and for those wheel makers, van, and wagon builders, and wheelwrights, workshops in which there is not sufficient work to warrant a costly plant of separate machines proves itself to be an ideal time and money-saver. It must not be confused with light, inferior

wheelwrights, so many of which are offered under the term "General Wheelwright," and which are far from being a success. Both the hand-power and steam-power machines are massively built, and are of the very best class of workmanship and material. The main frame is of heavy section casting, all fitting parts perfectly planned, and bedded. The bed is cast on one piece, accurately planned to carry the heavy head and tail stocks. The steel spindle runs in long phosphor-bronze bearings, the end thrust being taken up by an adjustable case-hardened steel rim. The various attachments are easily and quickly set up for performing their operations, the tools and attachments named below can be supplied in addition to that for mortising hubs.

Apparatus for Turning Hubs.

A countershaft is necessary with No. 1 steam power machine. The same firm makes an improved draw-spoke trimming and mitreing machine, with or without stand. In every cabinet-making and other wood-working shop there is ample use for one or more of these machines, and their adoption results in great saving in men's time. In mitreing, jointing and trimming hard or soft woods, at any angle, the work done is perfectly smooth and most satisfactory, making altogether unnecessary any further work for a first-class glue joint.

The main frame carrying the slides is heavily constructed, the table has a mitreing scale, adjustable mitreing fence and strong clamps for holding the timber in position. The knife slide is operated by means of a lever, rack and quadrant. The working of the machine is simple. It can be supplied by bolting it to a wooden bench or complete with stand.

ITEMS FROM "FACTORY."

Illuminating gas and compressed air are used to fire coke in one foundry cupola, instead of a wood fire.

Men work in pairs in one foundry. One more skilled gradually trains the other to the job until both can pair off as instructors.

Metal patterns made of an alloy, one-half tin and one-half zinc, have been found easier to finish than iron. They wear well and sand doesn't stick to the surfaces.

Each molder in one brass foundry has a numbered furnace. Bins of the same number hold the metal for each day weighed out in a metal room. The weight of the metal is charged against the bin number. After the heat, the weight of the castings, gates and so on is balanced against the original weight and the losses so accounted for.

Economic Handling of the Factory Output, Shipping, Etc.

The Canadian Fairbanks have Erected a New Warehouse in Toronto with Some Excellent Features for Taking Care of Factory Output.

There has just been completed on Bloor Street West, Toronto, for the use of The Fairbanks-Morse Canadian Manufacturing Co., a modern warehouse for taking care of the rapidly increasing business this firm is handling. The business of this company has grown so fast that a separate warehouse was found absolutely necessary for storing the goods so that orders might be promptly filled from stock.

Five years ago the Fairbanks-Morse Canadian Manufacturing Co. Ltd. was established to manufacture the lines made in the U. S. by Fairbanks-Morse & Co., of Chicago. This consisted mainly of industrial gas engines, and gasoline engines for farm power, but later on a large field for marine engines developed in Canada and this line was taken up also.

Other lines as steam, gasoline and power pumps, hand and motor railroad cars, hangers, bearings, railroad stand-pipes, Wissen stamps, etc., are now manufactured. Approximately 300 men are employed. Further enlargements in the near future are contemplated which will increase the output of the machine shop 75 per cent. and double the foundry capacity. In addition a brass foundry is being installed.

These extensions are being added to accommodate the manufacture of gas tractors for all the various kind of fuels, which business offers a very promising future.

The power plant will be increased by the addition of another 150 h.p. producer Fairbanks-Morse gas outfit, two of which are already in operation, bring-

ing the total horse-power developed up to 450 h.p.

The Canadian Fairbanks Co. handle exclusively the output of this factory through their offices at Montreal, Toronto, St. John, New Brunswick, Winnipeg, Calgary, and Vancouver.

Description of Warehouse.

The building in question is 80 ft. wide by 135 ft. long, and it consists of four storeys and a basement, and has been especially designed for handling all classes of machinery that this company build and, therefore, there are several features in connection with same which are somewhat out of the ordinary.

The building is built in what is known as "slow-burning" or "mill construction." The walls are built of brick and cement mortar with heavy timber posts and timber and steel beams with floors 6-inch thick; the ground floor being designed to carry a load of 250 lbs. to the square foot and the other floor 150 lbs. per square foot. The basement has a concrete floor finished over waterproofing material. The upper floors are finished with hardwood.

At the east side there is a shipping platform about 70 ft. long and 12 ft. wide, which is covered with a canopy and this platform is elevated above the level of the ground to the height of an express waggon, and from this platform local shipments of less than car loads lots of the lighter goods will be despatched. On the west side of the building there is a car dock long enough

to take in two standard railway freight cars, the track being depressed so that the car floors are level with the ground floor of the warehouse. On the same side of the building as the car dock, on the opposite end is a waggon dock approximately 21 ft. deep by 14 ft. wide with a 10 ft. door opening from same on to Bloor Street.

Over the railway dock and waggon dock referred to is located a crane runway with a ten ton electric traveling crane, Niles make, which is capable of lifting material off the ground floor of the warehouse and placing it on flat cars or on to the floor of heavy express waggons. This crane can also be used for loading materials which have to be shipped by rail on to flat cars. Adjoining the railway car dock is an industrial railway dock arranged so that material may be brought from the works where it is fabricated on a narrow gauge railway and brought into the warehouse; the industrial railway trucks being arranged so as to be level with the ground floor of the warehouse.

There is also located at the south end of the building an electric-driven elevator of 6,000 lbs. capacity for taking material up and down between the upper floors and the shipping floor of the warehouse. This elevator is enclosed in brick walls with skylight overhead, and operates between the basement and top floor; and adjoining the elevator shaft is a staircase which is also enclosed in brick walls in accordance with the requirements of the underwriters, and which would form in case of fire a safe escape for anyone



Construction of Fairbanks-Morse New Warehouse.



Track, Crane, Raised Platform, are Economical Features.

who might happen to be on the upper floor of the building at the time.

The front portion of the ground floor of the building has been reserved for the general offices of the works, and has been laid out with a fireproof vault

plaster on the walls and over the ceilings, which surface are tinted in soft tones.

Timekeepers' Offices.

Adjoining the building on the east side is a small one storey building

is within 6 ft. of the general grade of the ground around the building and it is therefore a simple matter for workmen arriving on bicycles to wheel same through the room, pass the clocks and out the door at the opposite end which leads to the works. The office of the timekeeper is located on the ground floor of the warehouse, in the office portion, and a small bay window has been provided overlooking the "Clock Room," from where the timekeeper can observe what is going on in this room.

This warehouse has been designed with a view to future extension to the south, and when extended, the stair-tower, over which is located at an elevation of 20 ft. above the roof a 25,000 gallon underwriters' sprinkler tank will be in the centre of the building. The building is equipped with Standard Automatic Sprinkler together with fire-hose at each floor and at roof for fighting small fires.

The floor of the upper stories of the warehouse have been built with a crown in the centre of the building and slope towards the walls, through which there are located on each side, in every alternate bay, cast iron scuppers with openings about 4 inches square and covered with cast iron hinged caps on the outside so as to allow any water which gets on the floor from the sprinklers to escape outside the building where no damage may be caused, such as might happen if the water had to find its way down from floor to floor and encounter merchandise on the way which would be more or less spoilt.

The cuts accompanying this article



New Warehouse of Fairbanks-Morse, Toronto.

adjoining same together with lavatories, private and general office, the interior of the office is finished in chestnut stains, dark brown finish and the walls, for a height of about 7 feet, are panelled in this material above which is

known as the "clock room," in which are located the time-clocks for the works; and all employees are obliged to pass through this room and punch the clock on entering and leaving the works. The floor of this "clock room"

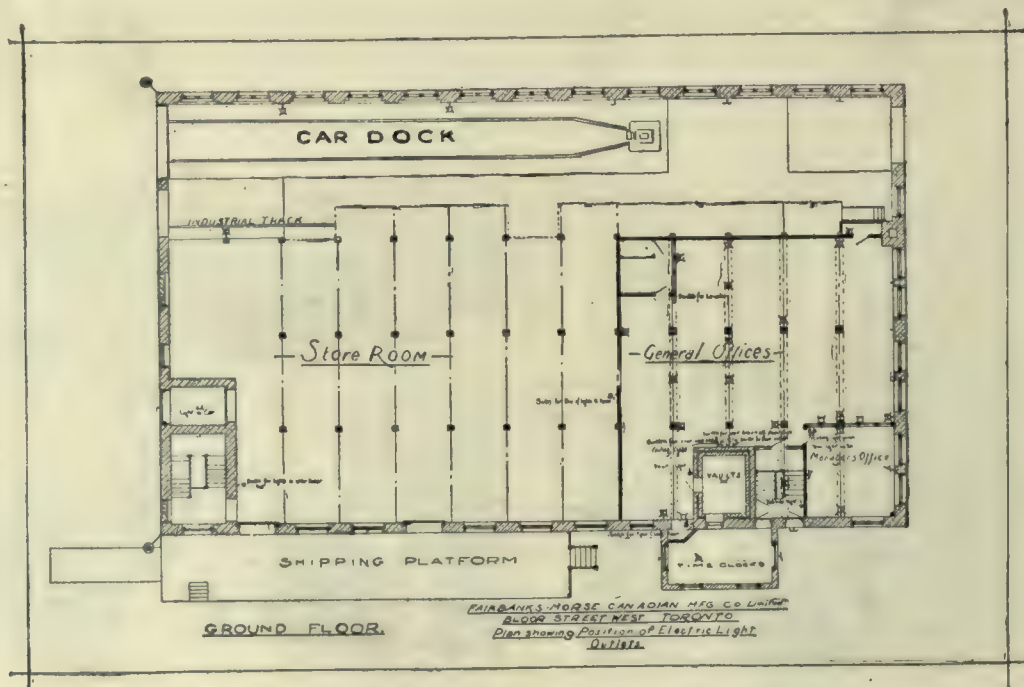

Plan of New Warehouse of Fairbanks-Morse Canadian Mfg. Co., Toronto.

show the general appearance of the Fairbanks-Morse Canadian Mfg. Co.'s plant and new building, which was designed by T. Pringle & Son, Limited, engineers and architects, of Montreal, who make a specialty of industrial work, and was constructed by C. E. Deakin, general contractor.

The whole work was carried out under the supervision of the designers, the work being started in November, 1909, and completed a few days ago.

next day's Wednesday, there's half the week gone and no work done. Yew'll have to git a hustle on if yer want ter keep yer darned job.'"

Making Milling Cutters.

He gave a description of the manufacture of milling cutters by the Union Twist Drill Co., Athol, in which English steel is used.

In the making of milling cutters a piece of steel must be removed to allow

and in which cast iron balls from 2 to 4 inches in diameter, tumble about pulverizing the ore, which when in its final state passes out with a current of circulating water.

From the mechanical standpoint the end bearings of both mill and drive-shaft and the ore-feeding device, are of interest.



Fig. 1.—Hardinge Conical Mill.

As both sets of bearings are of the same type only one is shown in Fig. 2. The bearing and bearing stand form a ball and socket joint, permitting a deviation of the mill from the horizontal position which is necessary when operating, without interfering with the vertical position of the bearing stands.

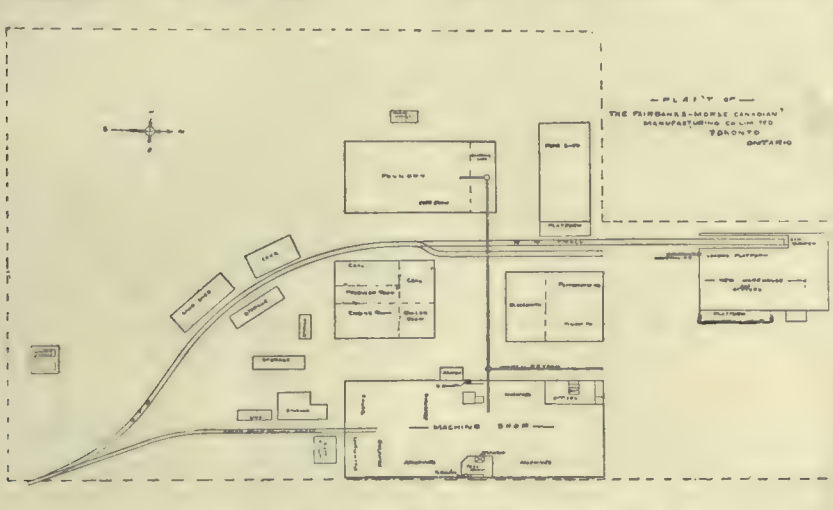

Layout of the Fairbanks-Morse Toronto Plant.

WORKSHOP PRACTICE IN UNITED STATES AND CANADA.

Recently, E. Theo. Crosier, of Newcastle-on-Tyne, Eng., made a tour of a number of United States and Canadian industries. His impressions were given before the Newcastle Y.M.C.A.. He pointed a number of comparisons between British and American methods:

1. Every workman washes himself and changes his clothes before he leaves the factory. I noticed navvies in the street taking off overalls at buzzer time.

2. Time recorders are used almost universally.

3. Employees are expected to attend to as many machines as is possible.

4. A great deal of work is done from jigs. All machines are higher speed.

5. The employer in walking through the works does not hesitate to speak to any workman, should he happen to be known to him.

I went through a very large drop forging factory with the vice-president of the company, who exchanged greetings with almost every other man he saw. I have never seen this done in this country (England).

6. The American loses no time. A well-known story has been adapted to illustrate this.

"A foreman entered the shop one Monday morning and found a workman wasting time, 'Say young feller' he said, 'I guess this won't do. Here's Monday morning, to-morrer's Tuesday and the

the cutter to be secured to mandril or arbor. This steel is cut out instead of being drilled out thus saving a piece of steel which can be utilized for making small cutters or saws. When a man gets a tool from the tool room he leaves a round check (1' x 1-32") bearing his number, this is put in the storing place of that particular tool until it is returned. By this means if a tool is missing one man, and one only, in the whole works is responsible.

In the twist drill department I noticed about half a dozen lads working 13 machines each. They took little looking after it is true, being automatic, but it is one big step towards cheap production. One room in this factory was particularly interesting, it contained the form tools for the making of cutters. There were stored here 11,000 of these tools, the average value of which was \$5. The man in attendance showed me one tool which cost \$40 to make (exclusive of the cost of steel), it was a screw cutting tool 168 threads over a length of 4", or 42 threads per inch.

CONICAL MILL.

The accompanying photo, Fig. 1, is of a Hardinge Conical Mill, a recent adaptation of the old stamp mill for the crushing of the more valuable mineral ores.

It consists of a conical, boiler-steel drum, which revolves about 30 r.p.m.

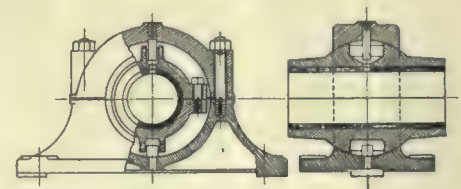

Fig. 2.—Bearing for Hardinge Conic Mill.

The slight slope of the drum is required to pass out the treated ore by gravity after pulverizing.

The ore to be crushed is in the form of small lumps. These are picked up by the scoop shown in Fig. 3. This dips into the ore box each revolution, feeding the ore into the mill, through

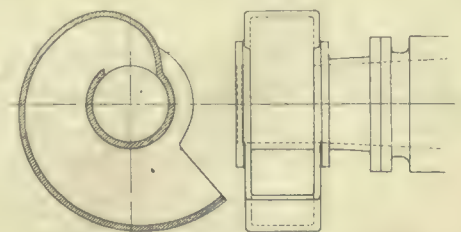

Fig. 3.—Pick-up Scoop for Hardinge Conical Mill

the hollow trunnion shaft. The noteworthy feature is the inner lip on the scoop, which prevents the ore from tumbling out when the revolution has been nearly completed.

MACHINE SHOP METHODS ^A_N^D DEVICES

Unique Ways of Doing Things in the Machine Shop. Readers' Opinions Concerning Shop Practice. Data for Machinists. Contributions paid for.

POWER FEED FOR TAIL STOCK DRILLING.

By J. H. R., Hamilton.

The accompanying sketch shows a device attached to tail-stock of a lathe where considerable drilling is required. The bracket B is secured to the tail-stock in the desired position. The small bracket D being secured to B to carry the worm W.

The shaft R is revolved from feed

a projecting pin in A, and on the upward stroke, A is drawn up, releasing the pin which engages one of the rivet holes, allowing the operator to move the article along.

About half way through the up-stroke, a projection of B strikes the stationary arm C, shoving B away, and allowing A to drop into the next rivet hole, holding it in that position during the punching operation.

arm A dropping about half way on the up-stroke, giving the operator time to adjust the article without shutting down.

This method ought to be applicable to other kinds of uniform line punching where extreme accuracy is not required.

HOLDING WORK WITH MAGNET.

At the Canada Cycle & Motor Co., Toronto, a grinding machine with a magnetic clutch is used to hold small parts during the grinding operation. In the manufacture of an automobile there are many small pieces that cannot be held conveniently in any other way. The pieces are held on a flat surface and hardened parts are accurately finished. It is also well adapted for finishing bright and true surfaces on small parts.

DRESSING GRINDING WHEELS.*

The difference between glazing and loading of a grinding wheel is not always clearly understood.

A loaded wheel is one whose face has particles of the metal being ground adhering to it—one in which the openings or pores of the wheel face have been filled up with metal, leaving no room for clearance. It is not necessary that all of the pores or openings between the cutting particles on the face of a wheel be filled up or loaded to prevent the wheel from cutting. The presence of a number of these pieces of metal on the face of a wheel prevents the wheel from cutting into the work and the loaded places will, of course, create heat.

A glazed wheel is one whose cutting particles have become dull or worn down even with the bond, the bond being so hard that it does not wear away fast enough to allow spaces between the cutting particles, or the cutting particles to escape when dulled. In a glazed wheel, the cutting particles and the bond at the extreme surface of the wheel are of the same radius.

It will be noted that in many places the space between the cutting particles is filled with bond and the corresponding spaces in the wheel on the left are open and will give room for clearance. Continued work with a wheel that glazes increases the smoothness of the wheel face and decreases the cutting.

A wheel will not load unless the bond is too hard or it is run at a speed very much too slow. The factors that cause loading are, therefore, hard bond and

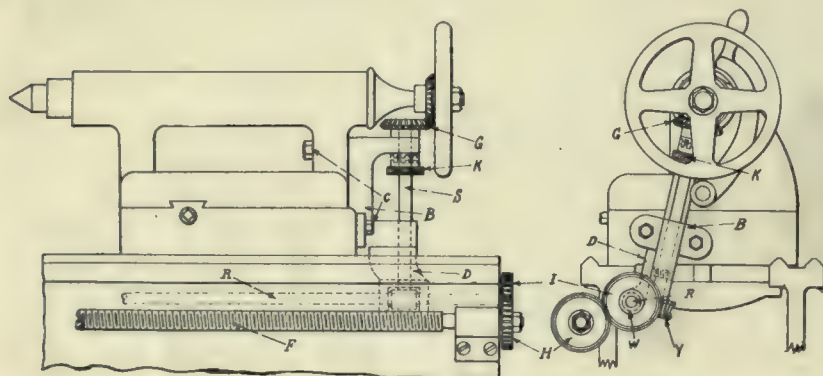

Power Feed for Tail Stock Drilling.

shaft F by the two gears H and I at the end of the lathe. On shaft R slides the worm W which revolves the worm wheel Y and shaft S. Motion is transmitted to the tail-stock spindle screw by an upward thrust of the knurled clutch nut K.

The feed shaft F is geared in the usual manner so as to transmit the desired feed to the tail-stock spindle.

SPACER FOR PUNCH PRESS.

Geo. R. Ward.

The steel sole of the shoe made by the Steel Shoe Co., Toronto, has an upward projecting rim which is riveted by small cleats to the vamp or upper. These rivets are spaced about 1/2 in. apart, the holes being punched.

Formerly, these holes, when being punched, were spaced by eye, as no degree of accuracy was essential; but this process proved to be poor, as it was impossible to keep the spacing in any way uniform.

The little device for the punch press shown in the cut was devised to overcome this difficulty. The arm A, which has a small pin in the line of rivets to engage with the rivet holes, is free to swing about its inner end. The arm B, which is freely attached to the punch press plunger, has a vertical motion with the latter. At the bottom of its stroke the cut-out in the side of B engages with

Any spacing may be obtained by changing A to make the desired distance between the die and the rivet hole pin in A.

The operation is extremely rapid, no stop being required between punches. This latter feature is insured by the

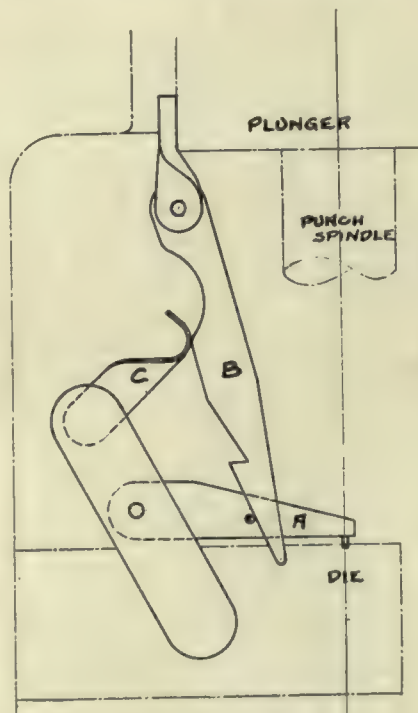

Spacer for Punch Press.

* Prepared by the Norton Co., Worcester, Mass., manufacturers of alundum grinding wheels.

slow speed. Loading may indicate that the wheel is too hard or that it is running too slow, or both.

The factors that cause glazing are hard bond and high speed. Glazing may indicate that the wheel is too hard for the work, or it may be running too fast. A wheel of the right grain and grade may glaze if run too fast; or a wheel run at the right speed may glaze if it is too hard for the work. In short, a wheel loads when it is too hard or when it runs too slow, and a wheel glazes when it is too hard or runs too fast.

One remedy for loading is to increase the speed. A remedy for glazing is to decrease the speed. If the speeds are right, use a softer wheel in either case.

Loading and glazing make excessive dressing necessary, and excessive dressing wears wheels faster than grinding. Were it possible to obtain an ideal wheel for each kind of work, theoretically dressing would not be necessary as the face of the wheel would automatically sharpen itself.

Whenever the work is of such a nature as to cause the wheel to run out of true, frequent dressing will save the wheel rather than waste it. For example, a wheel that ran out 1-32 of an inch after one hour's grinding ran out $\frac{1}{8}$ of an inch after two hours' grinding. Had it been dressed after the first hour and again after the second hour, the amount wasted by dressing would have been 1-16 of an inch, whereas after the wheel ran two hours it was necessary to dress off $\frac{1}{8}$ of an inch or twice as much.

Wheels should be kept in perfect running condition in order to give good results and a wheel should never be used until the operator is sure the wheel runs true.

We can never grind perfect work with an imperfect wheel, and the more perfect and smooth the wheel is the more perfect and smooth will the work be, particularly when making the light finishing cuts.

Dressers should always be kept handy for wheels for off-hand grinding but for truing wheels on plain, cylindrical and universal grinding machines, cutter and reamer grinders, etc., a diamond is necessary for good results.

Dressing is not truing, but sharpening the wheel, and a dresser should never be used on wheels that grind round work on centres. When truing a wheel for round grinding, the diamond should be held in a rigid tool post on the table of the machine. You cannot do good work with a wheel that has been trued "by hand." When a dresser is used, it should be moved in a straight line across the face of the wheel, with the heel of the dresser resting firmly against the edge of the work rest.

It may be well to state here that dressing is sharpening the wheel, and

trueing means to perfect the wheel—make a perfect cylinder of it, which is absolutely necessary if it is intended to grind a perfect cylinder with it.

PLANING A CONCAVE FACE CASTING.

By J. E. Hailstone.

The accompanying sketches illustrate a planing operation which, while perhaps not new to many readers, will, I have no doubt, prove interesting to some.

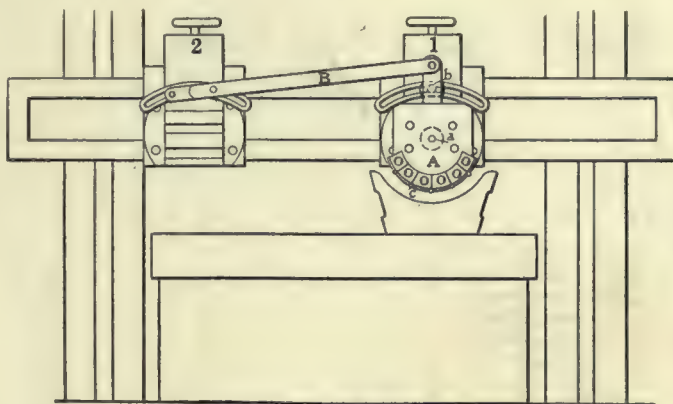

Fig. 1. Planer Rig and Tools for Planing Casting With Concave Face.

The casting to be planned may be seen on the table, Fig. 1. There were about two dozen of these castings, and they were machined all over, and buffed to a mirror-like polish on the curved surface.

All castings were faced on the base first, on the large slab miller. A special planer tool holder was made, having recesses for five tools, as shown at A, the arm projecting about 12 inches from the body giving considerable leverage and allowing the head to be kept fairly tight. The clamping studs of head No. 1 were replaced by stud b in the centre, giving the maximum swing desired for the finishing tool. A small hole was drilled immediately opposite the centre pin of the tool block (not the head) for locating the tool holders. The holder was clamped by the four bolts. By using the centre pin of the tool block it was possible to regulate the depth of cut without altering the radius.

Head No. 1, after being set central, was clamped to the cross rail and a small stop was placed at one end, the bar B connecting the two heads. As head No. 2 was moved, head No. 1 rotated about the centre a on a radius equal to that of the casting. The tools were ground to the standard shape, and by using the locating pin a in the holder the points were touched on the emery wheel to give the correct radius.

There being fine tools, it did not take long to machine the large concave surface. The smaller curves were roughed by a single tool in the holder and finished with a broad-nosed tool. The stop being set on one side, the head could be moved away to finish the smaller radius

and returned to a central position again without any bother. The stop was then changed to the opposite side of the head for the other small radius.

A special holder, Fig. 2, was made for finishing. The finishing tools for the smaller radius was ground to slightly larger radius than desired, to reduce the cut without interfering with the true form very much, and for the larger radius it was slightly smaller. The speed of the platen was reduced, and we ob-

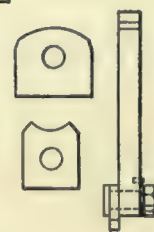
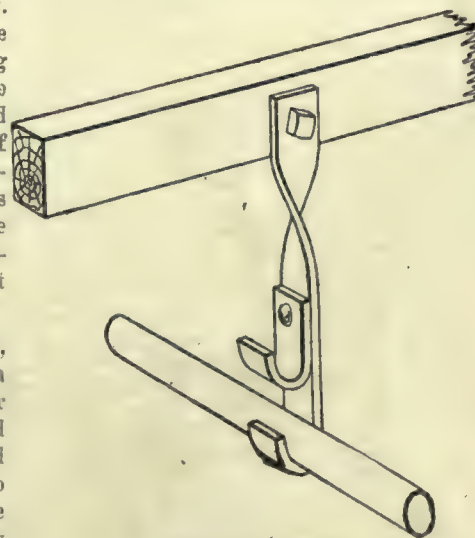

Fig. 2.

tained a very smooth finish. The stop was again used for finishing, with the head always in central position.—American Machinist.

SIMPLE PIPE HANGER.

The hanger shown in the sketch consists of two or more small hangers, riveted together in such a manner as to form hooks at the required distance from



Simple Pipe Hanger.

each other, says an exchange. The hangers are made of wrought iron, about $\frac{1}{2}$ -inch thick and 2 inches wide. The iron can be heated first and bent around a pipe of the same diameter as that which is to be used. This will prevent the pipe from vibrating after it is hung. If the pipes are to run in opposite directions, or to the beams above them, the iron

can be heated and twisted to the right angle. The upper end is drilled to receive a 1/2-inch lag screw, by which the hanger is fastened to the beam.

H.P. OF CAST IRON GEARS.

F=breadth, or face of tooth in inches
T=thickness of tooth at pitch line, inches.

V=velocity at pitch line in feet per minute.

(1) Horse power of spur gears= $\frac{F \times T^2 \times V}{L \times 53}$

(2) Horse power of bevel gears= $\frac{F \times T^2 \times V}{L \times 77}$

(3) Horse power of mitre gears= $\frac{F \times T^2 \times V}{L \times 82}$

of factors T and L in formulae (2) and (3) have been taken at large end of tooth, thus giving same dimensions as for spur gears; hence the spur gear formulae has been utilized, with the exception of the constant, which has been determined by averaging the proportions of the teeth of bevel and mitre gears having the largest and smallest number of teeth in general use. The resultant horse power is consequently less than in the case of spur gears of like pitch.

For mortise wheels and pinions use thickness of pinion tooth. If different factor of safety is desired, multiply above result by 7 and divide by factor of safety desired.

The Hill Clutch Co., Cleveland, recommend the following speeds in feet per minute as the maximum at which, under favorable conditions, it is safe to run toothed gears.

Ft. per Min.

Molded cast iron gears	1,500
Helical cast iron gears	2,000
Mortise cast iron gears	2,000
Molded cast steel gears	2,200
Helical cast steel gears	2,500
Machine cut cast iron gears.....	2,500
Machine cut cast steel gears.....	3,000

Although the above are conservative limits for safety, it is generally necessary to keep the speed much lower to avoid excessive noise and wear.

The two accompanying tables giving the horse power of head shafts and the horse power of line shafts were also prepared by the Hill Clutch Co.

Horse Power of Head Shafts

$D = \sqrt[3]{\frac{100 \times H}{R}}$ $H = \frac{D^3 \times R}{100}$

Diameter of Shaft in Inches	Number of Revolutions Per Minute							
	25	50	100	200	300	400	500	600
1 7/8	.85	1.7	3.4	6.8	10.2	13.6	17.	20.4
1 1/2	1.35	2.7	5.4	10.8	16.2	21.6	27.	32.4
1 1/4	2.	4.	8.	16.	24.	32.	40.	48.
2 3/8	2.8	5.7	11.4	22.8	34.2	45.6	57.	68.4
2 7/8	3.9	7.8	15.6	31.2	46.8	62.4	78.	93.6
2 1/2	5.2	10.5	21.	42.	63.	84.	105.	126.
2 1/4	6.7	13.5	27.	54.	81.	108.	135.	162.
3 1/8	8.5	17.	34.	68.	102.	136.	170.	204.
3 1/4	10.7	21.5	43.	86.	129.	172.	215.	258.
3 3/8	16.	32.	64.	128.	192.	256.	320.	384.
4 1/8	22.7	45.5	91.	182.	273.	364.	455.	546.
4 1/4	31.2	62.5	125.	250.	375.	500.	625.	750.
5 1/8	41.5	83.1	166.3	332.6	499.	665.	831.	998.
5 1/4	54.	108.	216.	432.	648.	864.	1080.	1296.
6 1/8	68.6	137.2	274.4	548.8	823.2	1097.6	1372.	1646.4
7	85.75	171.5	343.	686.	1029.	1372.	1715.	2058.
7 1/2	105.4	210.8	421.6	843.2	1264.8	1686.2	2108.	2529.6
8	128.	256.	512.	1024.	1536.	2048.	2560.	3072.
9	182.35	364.5	729.	1458.	2187.	2916.	3645.	4374.
10	250.	500.	1000.	2000.	3000.	4000.	5000.	6000.

Horse Power of Line Shafts

$D = \sqrt[3]{\frac{75 \times H}{R}}$ $H = \frac{D^3 \times R}{75}$

Diameter of Shaft in Inches	Number of Revolutions Per Minute							
	25	50	100	200	300	400	500	600
1 7/8	1.1	2.2	4.4	8.8	13.2	17.6	22.	26.4
1 1/2	1.8	3.6	7.2	14.4	21.6	28.8	36.	43.2
1 1/4	2.7	5.4	10.8	21.6	32.4	43.2	54.	64.8
2 3/8	3.7	7.4	14.8	29.6	44.4	59.2	74.	88.8
2 7/8	5.2	10.4	20.8	41.6	62.4	83.2	104.	124.8
2 1/2	6.9	13.8	27.6	55.2	82.8	110.4	138.	165.6
2 1/4	8.9	17.8	35.6	71.2	106.8	142.4	178.	213.6
3 1/8	11.3	22.6	45.2	90.4	135.6	180.8	226.	271.2
3 1/4	14.2	28.4	56.8	113.6	170.4	227.2	284.	340.8
3 3/8	21.3	42.6	85.2	170.4	255.6	340.8	426.	511.2
4 1/8	30.2	60.4	120.8	241.6	362.4	483.2	604.	724.8
4 1/4	41.6	83.2	166.4	332.8	499.2	665.6	832.	998.4
5 1/8	55.3	110.6	221.2	442.4	663.6	884.8	1108.	1327.2
5 1/4	72.	144.	288.	576.	864.	1152.	1440.	1728.

H=Horsepower. D=Diameter of shaft. R=Revolutions per minute.

L=length of tooth, from root to point, in inches.

C=constant.

HP=horse power transmitted with a safety of seven; ultimate tensile strength 25,000 lbs. per square inch.

In formulae 2 and 3 for bevel and mitre gears the factors T and L express the pitch at large end of tooth.

For bevel and mitre, thickness and length of teeth have been computed at centre of face. With a view, however, of facilitating calculation, the proportions

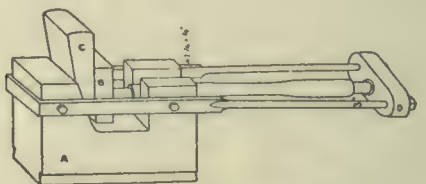

Device for Upsetting Collars on Axles.

quired, the backstop D also being recessed to receive collar. The operation is as follows:

The axles are first drawn a little each side of centre to permit of wheel fit being turned to required length; after this is done they are then taken up, heated on end for 3 or 4 ins., swung in crane from fire to hammer, and lowered into position, the block B being put in place backed by the wedge C. A few blows of the steam hammer

driving the wedge to place completes the operation.

Many hundreds of axles have been scrapped yearly by the different railroads after they have worn at the journal below the limit, when by upsetting a new collar on them, and using them for smaller capacity cars, their life is doubled. It was no doubt considered that the old method of upsetting collars on worn axles by the ram was too slow and laborious and did not pay, hence their relegation to the scrap heap. This die does the work quickly, and eliminates the hard labor needed for the ram, making it in every sense an economical method, as it doubles the length of service of axles so treated.

SPHERICAL BORING ATTACHMENT.

By G. R. Richards.

The design of spherical boring attachment illustrated herewith, is in use in one of the largest automobile concerns in the country. This attachment is used on the lathe in connection with a fixture that is fastened to the carriage for holding the work. It is held between the lathe centers and is driven by a dog. The boring tool is clamped in a tool-holder A that is attached to a pin B, which is free to turn in the bar. The upper end of the tool-holder is connected with a slide C by two links. Through this slide the feed-screw of the tool passes. As the bar revolves, the star-wheel E is actuated by a dog which is clamped to the tailstock spindle, thus giving the

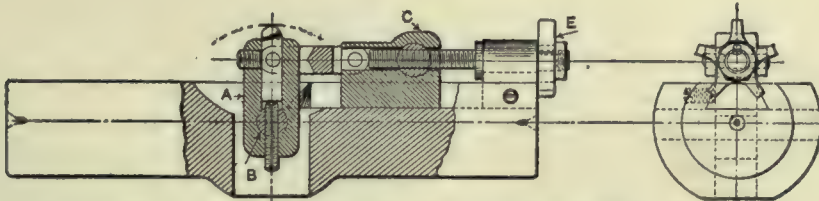
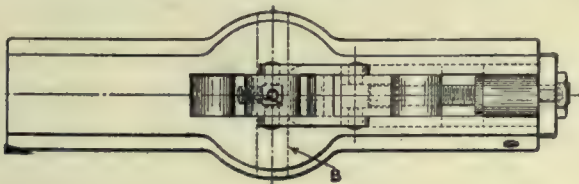

Compact Design of Spherical Boring Attachment for Lathe.

tool a circular movement about the axis of the pin B, as indicated by the dotted line. This movement combined with the regular rotary movement of the tool produces the spherical surface.—Machinery.

NUT FACING MACHINE.

The features about this machine are the half-ball collar A, on which the nut seats without forcing the thread in the nut out of parallel with the thread on the arbor and the clutch B, operated by the tool carriage without any extra lever. As the carriage is moved to the right

after a nut is faced, it opens the spring chuck, pushes the sleeve D against the loose pulley E, revolving in the opposite direction, causes a sudden reverse and loosens the nut.

A contrary result is obtained by moving the carriage to the left, the sleeve D coming in contact with the fingers F, pulls back the sleeve G and closes the chuck on to spindle H, carrying the nut to be faced. I is a flat beam slotted to admit the gear J, which is set in motion by the

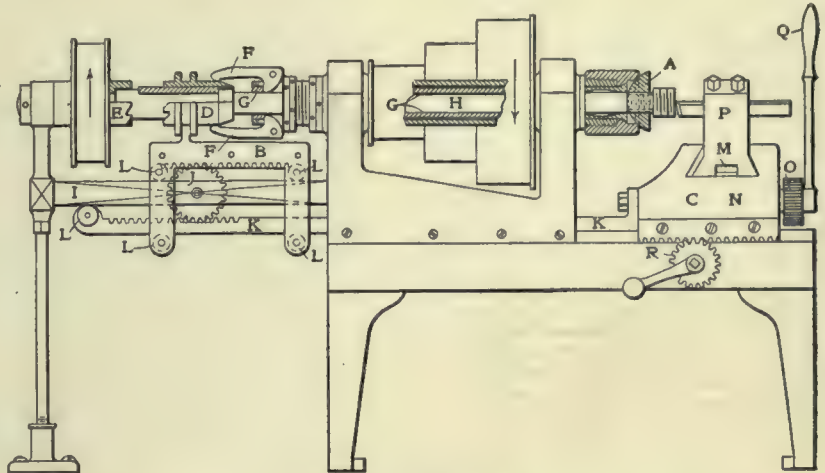

Nut Facing Machine.

rack K passing through cone carrier and attached to the carriage C. L L L L L are rollers to avoid friction on the beam I and rack K. M is a rack fastened to the bottom of the tool post. It is operated by a gear N, not shown. O is a

Mortising Teeth in Cast Iron Centre.

A number of readers of Canadian Machinery are no doubt familiar with the old mortise-tooth gearing so much in vogue in British mill work of the past generation—hardwood teeth mortised and dowelled into a tough cast iron centre. Is it not possible to adopt this method mechanically and commercially to modern requirements?—to construct a gear wheel having a low carbon mild or alloy steel centre fitted in the same manner with high carbon teeth, hardened, fitted and ground with mathematical accuracy.

Modern machine-shop tools and methods make this principle of construction quite possible, and, though the cost of production would necessarily be high, the advantages for high-class work would be very great, for I think that by these means a scientifically perfect gear could be produced.

Comments from readers of Canadian Machinery would be appreciated.—Subscriber.

Automobile Parts.

If you have a list of Canadian manufacturers of automobile parts, will you kindly let us have same as we will soon be in the market to make purchases.—Ontario Manufacturer.

If Canadian manufacturers of automobile parts will write us telling what parts they make with particulars we will forward the information to the inquirer.—Editor.

Steam, water, gas, electric conduits and other piping is distinguished in one plant by a system of colors. High pressure steam lines white, low pressure heating lines aluminum bronze, exhaust lines grey, heating returns aluminum bronze, house supplies maroon, water supplies red, drains pink, drips black.

Filing Papers.

Having read with some interest in several articles in technical and trade papers on the subject of "Ready Reference" to the different articles therein, I would like to bring to your notice an idea which would I think help to a great extent the keeping in touch with articles appearing in past issues of the technical and trade papers.

If a loose sheet or page were inserted in each copy of a paper, containing the heading or title of each important article therein, the subscriber on receipt

FIRST AID TO INJURED.

Considerable attention is being paid by the Canadian Pacific management to the work of the St. John Ambulance "First Aid" movement within the company, and it is the intention of the company to support this by giving every facility and inducement to the men on their passenger trains to learn what they should do in case of accident. The co-operation of the company with the St. John Ambulance people is a good deal more than passive, and orders have been issued, advising train employees that they

knowledge that Canadian Pacific employees will obtain by furnishing an emergency medical outfit to vans as soon as conductors have passed examination showing that they are capable of rendering first aid, and these outfits will be supplied as certificates are issued to conductors.

Passenger train crews are expected to take lectures and make themselves efficient, and emergency outfits will, as now, be carried in all sleeping cars. If no sleeping car is on the train the medical outfit will form part of the conductor's equipment.

Detailed instructions as to the handling of the boxes will be issued later.

It is the wish of the company that trainmen take an interest in this work, not only for the benefit of passengers, but for the benefit of employes generally.

Information as to the holding of classes will be bulletined from time to time at divisional points by the Canadian Pacific Railway Centre of the St. John Ambulance Association.

PERSONAL.

Fred W. Evans, manager of the machinery department of the Canadian Fairbanks Co., Montreal, was married recently to Miss Edna Hurd, of Toronto.

Thomas Reed has succeeded the late Frederick E. C. Baldwin, as sales manager of the Walpole Rubber Co. Mr. Reed's headquarters are in the Eastern Townships Bank Bldg., Montreal.

William S. Leslie, president of the firm of A. C. Leslie & Co., and Miss Margaret Wilson, daughter of the late James R. Wilson, of Sanquhar, Scotland, were married on June 15th. The ceremony was conducted in St. Helen's Church, Sanquhar, by the Rev. J. Richmond Wood, assisted by the Rev. J. Scott, of Toronto.

\$10 For An Idea

For the "Business Management" department of Canadian Machinery.

We want ideas for this department—ideas of practical, labor-saving, cost-reducing value. We will pay at regular rates for each idea accepted, and in addition will pay \$10 for the best idea submitted during the next five months—that is, until Sept. 30, 1910.

Address all communications to the Editor of Canadian Machinery, 143-149 University Ave., Toronto, Ont.

Subject	Article	Author	Page	Remarks	
General	The Effect of the Automobile Industry on Machine Tools	R. Pierpont	31		
	Solving Transportation of Material in Machine Shops	Dom. Bridge Co.	34		
	Semi-Annual Eng. Convention		35		
	The Patent Relation of Canada to the World	Int. Commission	37		
	"Beaver" Quick Changing Chucks and Collet Sets	Ham. Tool Co.	38		
	Technical Education Commission		38		
	Business Management	The Easiest Profits	Jas. H. Collins	39	
		Shop Secrets	Jno. R. Godfrey	41	
		Shop Methods and Devices			
	Machine Shop	Ball Race Calipers	Can. Cyc. & Mot. Co.	42	
Centre for turning Patterns, Jig for Gear Teeth		Stewart & Co., Galt	42		
Valve Seat Grinder, Shop Bucket for Inflammables, Punching Malleable Rings		S. F. Bowser Co.	42		
Drill Stands		Jno. Inglis Co.	43		
Draughtsman's Point			43		
Babbitting Bearings			44		
Drilling Connecting Rod Ends		Machinery	44		
Correspondence		Ejector Manufacturer		44	
		Cable Transmission			
		Design of Bevel Gears			
	Wax Patterns				
	Newall Tolerance Standard				
Editorial	Demonstrating Mach. Tools		45		
	Will Prices Advance				
	Protect the Machines				
	Canada's Large Trade				
	Canada's Patent Relation				
Developments in Machinery	Fall of Water Tanks		46		
	Eclipse Bolt-Heating Forge, Rivet Heating Furnace	Monarch Eng. Co.	47		
	Heating Iron and Steel for Forging		48		
	Radial Drill	London Tool	49		
	Improved Bevel Protractor	B. & S.	50		
	Barnes Tapping Mach.	Barnes Drill Co.			
	Free College Course				
	Conventions Foundrymen's at Detroit		51		
	Industrial and Construction		63		
	Book Reviews and Catalogues.				

of his paper each month or week, extracts the sheet and places it on file.

If a reader is in need of information on any subject you can in a few minutes, by glancing through the file, see if such information or anything touching on the matter has been published in the said paper even if it is several years back. A reader can, therefore, if the papers have been carefully placed find it in a few minutes.

The enclosed draft will give you an idea of the loose sheet, the blank space for "Remarks" to be used by each individual reader as becomes his needs.—
J. H. R.

are expected to take lectures on this subject and make themselves efficient in "First Aid work," not only for the benefit of passengers, but for their own good. In following up this movement it is announced that emergency medical outfits will be supplied as fast as conductors show themselves possessed of the necessary knowledge to handle them.

In this connection the following circular has been issued by Mr. J. W. Leonard, general manager of eastern lines:—

It is the intention of the company in connection with St. John Ambulance "First Aid" lectures to supplement the

DEVELOPMENTS IN MACHINERY

New Machinery for Machine Shop, Foundry, Pattern Shop, Planing Mill; New Engines, Boilers, Electrical Machinery, Transmission Devices.

COPING AND PUNCHING MACHINE

This machine, the latest punching machine of large capacity, placed on the market by the London Machine Tool Co., Hamilton, is designed for the rapid punching, coping and shearing of I

with a shrouded pinion, necessitated by the heavy strains.

The machine is of a very powerful type, and several have been in operation in different works, giving good service.

The total weight is 36,000 lbs.

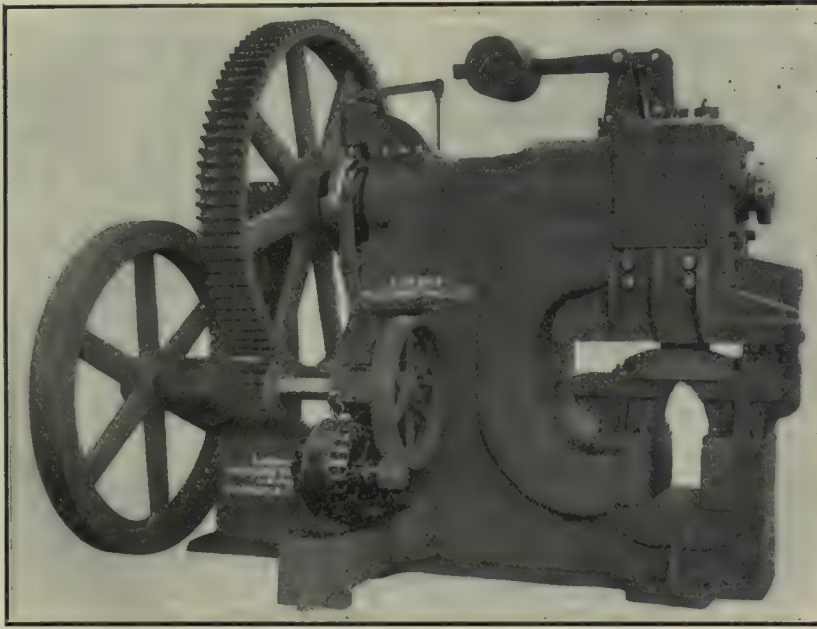

Coping and Punching Machine, London Machine Tool Co., Hamilton.

beams and other structural shapes, and is capable of punching four 1¼-in. holes. The main dimensions are as follows: Distance from centre of plunger to back of throat, 25 in.; maximum distance from outside of horn of plunger to the throat, 46½ in.; maximum distance from plunger to base when stroke is up with blocks removed, 28¾ in.; main gear has 96 teeth, 2½-in. pitch, and 9-in. face; pinion has 14 teeth, and the fly-wheel is 5 ft. 6 in. in diameter. When arranged for electric drive, as shown, a 10 h.p. constant speed motor is required, or if belt drive, 30x6-in. pulleys.

The frame is of close-grained iron, designed with a high factor of safety, the metal arranged in box section. A 10-in. forged steel shaft, running in bronze bearings, transmits power to the punch, which has a 2-in. stroke. The outer end of the shaft is provided with a support to take the strain, obviating bending in the cam portion of the shaft.

The pintle is of cast steel, bronze-bushed, and working in a hardened steel knuckle. Taper jibs of bronze are provided for the steel plunger to take up the wear. The main gear is of large diameter, coarse pitch and wide face,

HYDROSTATIC WHEEL PRESS.

Herewith is illustrated a new design of locomotive hydrostatic wheel press of convertible type, recently placed on the market by the John Bertram & Sons

Co., Dundas, Ont. The design is such as to permit of building the machine in stock lots, and where an order is received for a machine of the inclined type to facilitate the handling of wheels and axles directly into the machine by the regular overhead shop cranes, the tension bars may be so located that they do not interfere with crane tackle. Other users prefer the vertical position that they may handle axles with the carrying hooks provided with the machine, and the bars can be placed to meet their views without any alteration to the machine. This is a benefit to the user as well as builder, for this change can be made at any time, either before or after installation in the shop. This and other features are fully covered by patents.

The triple plunger pump has separate control for each plunger, so all or each may be brought into action as required. Great speed of ram is thereby obtained and all the delivery pipes being of large diameter, the return of ram by balance weights is rapid. Drive can be changed from motor to belt, parallel or at right-angles, after the machine is completed. Suitable blocks are furnished for car as well as for locomotive wheels.

MOTOR-DRIVEN SHAPER.

The motor shown connected to the 24-in. back-geared crank shaper in the illustration has a speed range of from 450 to 1,350 r.p.m. By means of the face-plate controller, located on the side of the

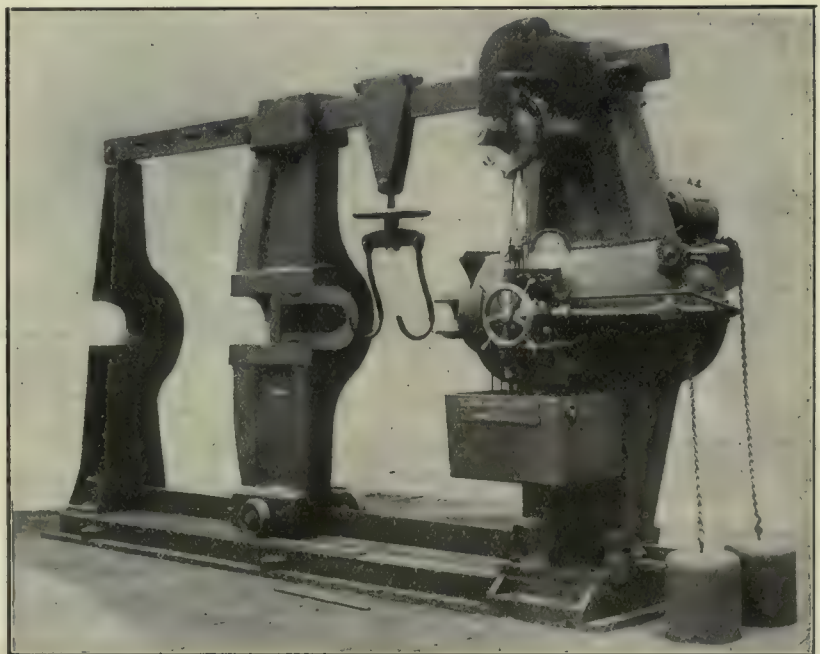

Hydrostatic Wheel Press, John Bertram & Sons Co., Dundas.

shaper, the workman can regulate the speed to suit the requirements of his work. A large number of operating speeds, limited only by the number of field resistance steps on the controller, are thereby available, and the correct speed for most efficient operation on each piece of work is easily and quickly obtained. On each position of the controller, the speed of the motor is practically constant for all rated loads. This characteristic is of great importance in machine tool service, as it reduces tool breakage to a minimum. The controller

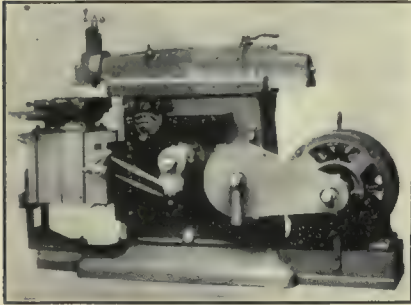

Motor Driven Shaper, Queen City Machine Tool Co.

handle is within easy reach of the operator, who can make any speed adjustment or stop the shaper instantly while standing at the rail.

The use of a silent chain as a method of connecting the motor to the shaper eliminates belt slippage and provides a positive driving power. The chain runs very smoothly and without perceptible vibration. The motor is supported on a sub-base cast integral with the base of the shaper. The equipment is compact and takes up little floor space.

This shaper is made by the Queen City Machine Tool Company, and is driven by a Westinghouse type "SA" 5½ h.p. motor, with auxiliary commutating poles.

RAWHIDE PINIONS ON GEAR DRIVES.

Rawhide pinions are usually considered merely as a means of stopping noise on medium and high speed drives and by far the largest percentage of them are used for that purpose. It is a matter of engineering experience, however, that rawhide is quite beneficial on gear drives where there is vibration from irregular load, etc.

This is well illustrated in the instance of the 1,750 gallon quintuplex pump in the power plant of the Parral Power & Reduction Co., Parral, Chihuahua, Mexico. This pump as shown in the illustration is geared through double reduction to an induction motor and furnishes the circulating water for the condenser.

Originally this pump was driven entirely by cut steel pinions and cast iron gears. The pump was of so light a pattern that there was considerable spring in both shaft and frame. The result was constant annoyance from broken gear teeth and in addition to gear renewals, there was quite an expense due to the power loss of running the engines non-condensing while pump repairs were being made. The chief engineer had about decided to abandon the pump and replace it with another of different design when someone suggested the use of rawhide pinions. Accordingly, four New Process Pinions made by The New Process Raw Hide Co., of Syracuse, N.Y., were substituted for the four steel pinions. Two of these are shown in the photograph, one on the motor and the other meshing with the big gear on the left. The other two are on the other side of the motor and placed symmetrically to those shown. These rawhide pinions were put into service over two years ago and there has not been a moment's trouble with the gearing since. In fact the pump has been out of service only long enough to re-pack the plungers and replace the rubber valves.

Rawhide when properly cured and machined makes up into a gear or pinion that is much the same as metal, except that it has no metallic ring and is more elastic. This elasticity is highly

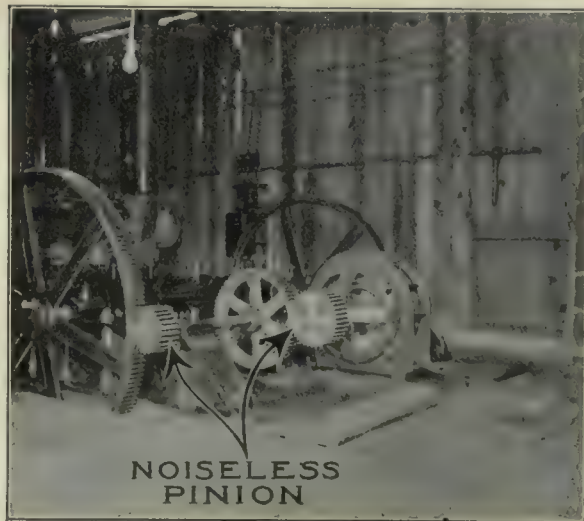

Pump Motor Drive Using Rawhide Pinions Made by New Process Raw Hide Co., Syracuse.

advantageous on motor and other drives in that it absorbs the shock as large gear teeth come into contact and as cutting tools come into cutting contact, and it cushions the irregularity of load due to the reciprocating movement of parts in machine tools or geared power plant apparatus.

UNIVERSAL CHANNEL SHEARS.

The accompanying illustration shows a motor driven universal shear for squaring and mitring channels, angles and plates, used in structural steel work. This machine was built especially for the marine department of the Maryland Steel Co., Sparrows Point, Maryland,

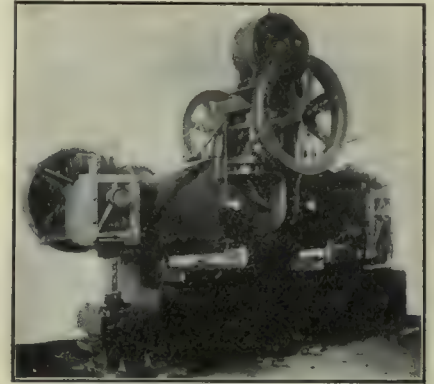

Punch and Shears—Covington Machine Co.

but would be found very useful in any iron works where steel forms must be cut for construction work.

This machine has a coping attachment at one end, a plate shear at the other and two intermediate 45-degree angle shears. The coping attachment can also be used as a punch.

It is built by the Covington Machine Co., of Covington, Va., and is equipped with a 25 h.p. type S direct current

motor manufactured by the Westinghouse Electric and Manufacturing Co., Pittsburg, Pa.

MOTOR DRIVEN PUMP.

The accompanying cut illustrates an automatic feed pump and receiver, equipped with motor driven rotary pump,

built by the Smart-Turner Machine Co., Limited, Hamilton. These outfits are specially designed for returning water of condensation to boilers, in plants where the boiler pressure is in the neighborhood of one or two pounds per square inch. The same receiver, with regulat-

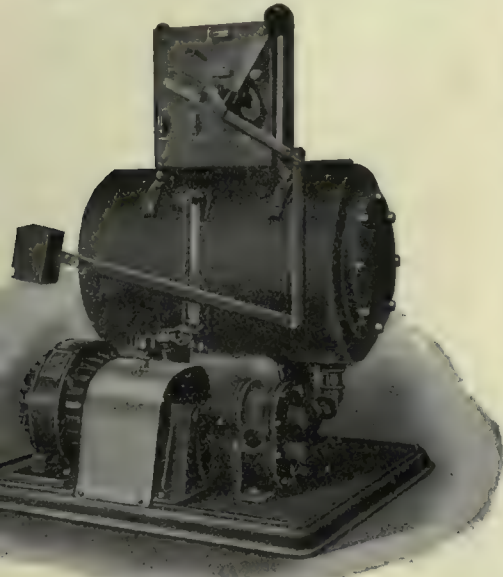

Smart-Turner Motor Driven Pump.

ing device, etc., may be used in conjunction with either of their Centrifugal, Triplex or Duplex Power Pumps.

NEW PIPE THREADING MACHINE.

The motor driven pipe threading machine shown by the accompanying picture is one of several recently installed by the Stoever Foundry and Manufacturing Co., Myerstown, Pa., at the pipe mill of the Spang-Chalfant Co., Sharpsburg, Pa. The capacity of the machine is from 4 to 12 inches inclusive. The installation is of especial interest in that the pipe threader is the fastest machine



Stoever Pipe Threading Machine Equipped with Westinghouse Motor.

for threading or cutting pipe on the market. It is threading pipe at the rate of 28 feet per minute; a very fast speed for a tool of this size.

The machine is driven by a Westinghouse type, "HS" squirrel cage induction mill motor, which has the rugged construction and the general reliability required for such service. The normal rating of the motor is 10 horsepower and the full load speed is 875 r.p.m. on a

three phase, 25 cycle, 200 volt circuit. Squirrel cage induction motors of suitable design are especially appropriate for this class of service, since the speed is constant and there are no sliding contacts. The motor shown has the distinction of being the first squirrel cage induction motor designed especially for heavy mill service; the only wearing parts are the bearings, which are very large, rigid and self oiling, and capable of maximum service. The motor is started by means of a Westinghouse auto-starter.

UNIVERSAL RADIAL DRILL.

The machine shown in the accompanying illustration is a new full universal triple-gear radial drill recently brought out by the American Tool Works Co., Cincinnati. This machine is an entirely new development in the field of radial drills built in 4, 5, 6 and 7-in. arms lengths.

The design of the arm of this new universal radial has eliminated many weaknesses. It is made in the form of upper and lower tube sections which are bound together in the back by a double wall of metal and further reinforced by heavy transverse ribbing. On the front wall "ways" are formed for carrying the unusually wide and rigid saddle, which is firmly locked at any point along the arm by means of a powerful clamping device. This, in addition, binds together the double arm sections and saddle into a very compact unit, thus affording unparalleled strength for resisting all strains. Arm is clamped to column by two binder levers, obviating loose wrenches, and is raised and lowered rapidly by a double thread coarse pitch screw, hung on ball bearings, and controlled by a convenient lever, marked ears indicating the proper direction to throw lever for raising or lowering. This lever cannot be operated until slightly raised from its bearing, thus guarding against accident through unintentional movement while the arm is clamped to column. Arm is rotated in a complete circle by worm engaging worm wheel cut in the periphery of the arm flange. This movement, in connection with the swivelling head, permits drilling and tapping at any angle radiating from the centre of a sphere and is firmly clamped, as set, by four large binder bolts. Arm is graduated in degrees on its periphery, readings being taken at a fixed pointer.

The head is of very compact design and is equipped with powerful steel triple gears. It may be swivelled through a complete circle by means of a hand wheel and worm which engages a worm wheel fixed to the head. This feature is of special value in setting the spindle

for angular drilling. The worm holds the swivelling head in any position and eliminate all possibility of accident, through the head swinging around of its own weight, when the clamping bolts are loosened. The hand wheel affords quicker motion than the use of a wrench. Graduation on head show, at a fixed pointer, the angle as set, and three binder bolts are provided for securely clamping the head at any angle. Head is moved rapidly along the arm by means of multiple gearing and rack, through the same hand wheel that swivels the head, by simply engaging the clutch shown. A binder is supplied which permits of readily locking the head at any point along the arm.

A feature of merit is found in the power-transmitting elements between the arm shaft and the spindle. The saddle shaft, which forms part of this connection, is offset to one side of the spindle and is mounted in two long bearings, one of which is integral with the saddle and the other with the swivelling head. Power is transmitted from the saddle shaft, through mitre gears, to a shaft in the front head, from which the spindle is driven through spur gears. This construction eliminates the cramping, consequent loss of power and rapid wear.

The spindle has 24 changes of speed, with speed box drive, or cone pulley drive with double friction countershaft, advancing in geometrical progression, ranging from 19 to 314 r.p.m., all immediately available by means of two levers, without stopping the machine. The wide range of speeds obtainable, together with the enormous power and unusual rigidity, render this drill equally efficient when using either the ordinary carbon or high speed twist drills, and particularly fits it for a wide range of tapping requirements. A speed plate, fixed to the arm girdle, shows at a glance how to obtain suitable speeds for the work being operated upon. Spindle is provided with both hand and power feeds also with quick advance and return.

Triple gears are made of steel, are of powerful design and provide one direct and two reduced speeds, through the medium of spur gears and positive clutches. They are operated from the front of the head saddle by a convenient lever, without stopping the machine. Triple gears are mounted on the back of the saddle and are fully enclosed by the upper walls of the arm, thus permitting the universal arm to be rotated through a complete circle with no possibility of any overhanging mechanism interfering with the work being machined. This is a distinct feature on this drill.

Feeding mechanism is located on the head and provides eight distinct rates of positive geared feed, covering a care-

fully chosen range in geometrical progression from .006-in. to .060 in. per rev. of spindle. This mechanism is controlled by two dials, on the face of which the respective feeds are plainly indicated. Any one of the feeds is instantly obtained by merely turning the dial until the desired feed comes opposite a fixed pointer. The rate of feed being used is plainly indicated at all times and reference to index plates is unnecessary. The feed train is engaged and disengaged at the worm wheel through a friction trols the quick advance and return of clutch and lever, which lever also controls the spindle. This feed friction is so de-

ping attachment is located between the speed box and triple gears, the frictions, already very powerful, receive the benefit of the triple gear ratio and have comparatively light duty to perform, thus making possible unusually heavy tapping without undue strain, and permitting taps to be withdrawn at an accelerated speed. The great power of the frictions require but a light adjustment, and the lever operating same is consequently thrown in and out of engagement with very slight amount of effort.

The speed box is of the cone and tumbler type and provides eight changes of speed, each one of which is instantly

smelters for treatment during the fiscal year ended March 31, 1910, operated as follows :

There was a total production of 45,467,545 pounds, and the bounty, \$15 per ton, amounted to \$340,542. The bounty paid for the fiscal year 1909 was \$307,432, indicating a production of 42,533,387 pounds of ore. The Canadian lead production is chiefly from the Kootenay mines in British Columbia, and a few years ago was shipped almost entirely to the smelters in the United States. The bounty system has resulted in the ore being smelted in Canada and, to a large extent, used in

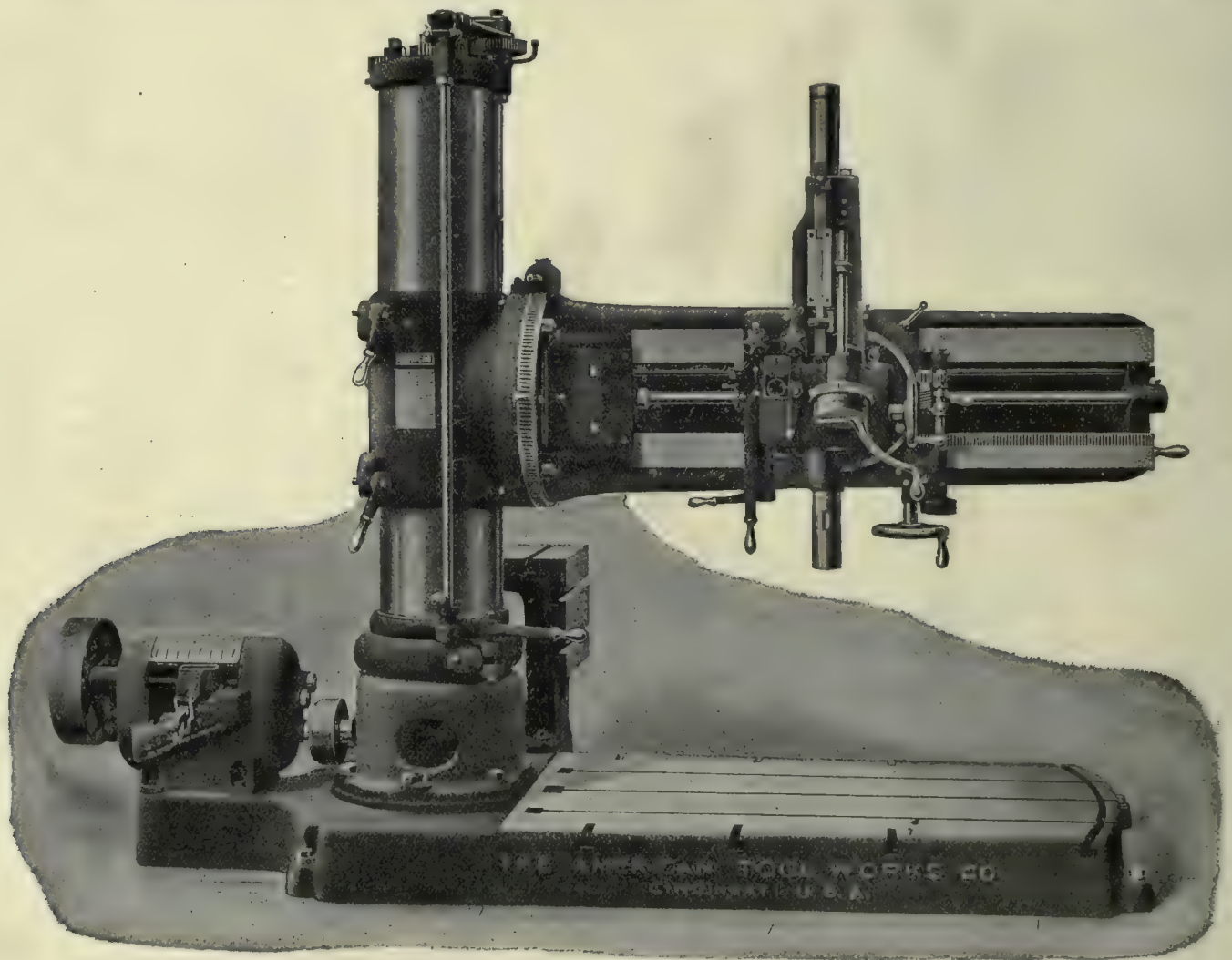

Radial Drill, The American Tool Works Co., Cincinnati.

signed as to permit the machine being crowded to the limit of its capacity without unduly straining the feed works.

The tapping mechanism operates through our patented double band friction clutches, which afford considerable more frictional power than any other type of friction of similar size. The lever for operating this mechanism is placed on the front of saddle and controls the starting, stopping and reversing of the spindle. Owing to the fact that the tap-

available by the mere shifting of the tumbler lever. All gears in box are made of steel and are of very coarse pitch and wide face. The gears in speed box are of the Brown & Sharpe "20 degree involute pointed tooth system."

CANADA'S LEAD BOUNTIES.

The Dominion government bounty for the production of lead ore from Canadian mines, delivered at Canadian

this country in the manufacture of white lead and other products. The bounty is paid upon a sliding scale, based upon the price of lead in London. It is 75 cents per 100 pounds until the price in London exceeds £14 10s. (\$70.56) per ton. Should the price on the London market reach £18 (\$87.60) the Canadian bounty would cease altogether. But this is not likely to happen. The London quotation on July 1 was \$61.10.

POWER GENERATION ^A_D APPLICATION

For Manufacturers. Cost and Efficiency Articles Rather Than Technical.
Steam Power Plants ; Hydro Electric Development ; Producer Gas, Etc.

POWER AT 25 CYCLES vs. 60 CYCLES

By C. L. Gulley, B.A.Sc.

The conditions that to-day exist in the central station business in the City of Toronto, are not new to the electrical profession, as they are being experienced or discussed in every city of any size in Canada and the United States. The electrical world has seen advances in the last few years that at first seemed incredible, and at which people still wonder. Among these advances is one which is attracting the attention of the citizens of Toronto, possibly more than any other; the writer has reference to the enormous strides taken in the development of the transmission line. The reason for this is directly due to the degree of perfection to which the insulation problem has been worked. Not many years ago 110,000 volts was considered by electrical engineers as impracticable, owing to the difficulties experienced in obtaining an insulating material, which would stand up under such a strain. However, these difficulties have been met and overcome, and to-day, as a result, we have entering the City of Toronto, a transmission line, which will work under a pressure of 110,000 volts.

Power, in electrical units, is the product of volts and amperes; so that, within limits, for a definite amount of power transmitted the higher the voltage the smaller will be the current, which means the line loss will be smaller as the line loss, which mainly consists of copper loss, depends upon the amount of current flowing. Thus, any means of lessening the current is immediately substituted, and as can be seen from the above statement the only way to do this is by increasing the voltage under which the line is being worked. Also, as the current is decreased the cross-section of transmitting copper can be decreased, which means a very considerable saving in the line copper. Also as the copper is decreased, the weight of the line is decreased, causing a decrease in the size, strength and number of the towers. On the other hand, as the voltage is increased (i.e. decreasing the current for a definite amount of power transmitted), the cost of insulating the line increases very rapidly. Thus, as we evade one source of expense to the first cost of the line we encounter the other. However, for any large amount of power transmitted on a low voltage line, the line loss as well as the cost of the

copper and towers necessary would be enormous, and would more than balance the increased cost of insulating the high voltage line.

The 25 cycle problem, which is being worked out in Toronto is one which depends directly upon the transmission line, as power can be transmitted more cheaply, i.e., with less line loss, at 25 cycle per second, than at 60 cycle per second. Anything that will lessen line loss without materially affecting line cost is at once grasped.

Line loss depends upon the resistance and the inductive reactance of copper wire, and the charging and leakage current. The last two depend upon the voltage of transmission.

From the table of physical and electrical constants of copper wire for Matthiessen standard wire at 60 degrees Fahrenheit for transmission line calculations, as found in the Standard Handbook for electrical engineers, we find a very considerable difference in the charging current and inductive reactance, when calculated for 25 and 60 cycles.

Table of Physical and Electrical Constants for Copper Wire.

Frequency in cycles per sec.	Size of wire, B. and S.	Interaxial distance in inches.	Resistance per mile of one wire in ohms.	Inductive resistance per mile of one wire in ohms.	Charging current in amperes per mile per 100 volts between wire & neutral.
25	No. 0000	72	.2540	.3033	.00243
60	0000	72	.2540	.7278	.00584

The writer has chosen the constants affected by the frequency, and in each case it is found that the line loss will be decreased by transmitting at 25 cycles instead of 60. The resistance of the copper wire and the leakage current are unaffected, but the inductive reactance and the charging current are each decreased 58 per cent.

Before the days of the long transmission lines, alternating current was practically standardized at 60 cycles per second. However, now that the citizens of Toronto are being supplied with power from Niagara Falls at 25 cycles per second, it means that the

central station man must either install special motor generator sets to change the frequency or arrange to have the 60 cycle apparatus removed and replaced by similar 25 cycle machines. In the case where there are a great many consumers already using current at 60 cycles per second it is a better proposition for the central station man to install his frequency changes and to stand the increased loss in the changing of the current, and in distributing to his customers, but where the consumers are comparatively few and scattered over large areas it is better for him to have the system changed as a few customers can be changed with very little trouble for the customers or for him. On this account we find the Toronto Electric Light Company changing its current in the outskirts of Toronto, where industrial power-using establishments are scattered.

One great drawback to 25 cycle current is that it will not operate satisfactorily an arc lamp. Where an arc must be used, as in a moving picture theatre in which place a most intense light is necessary, it means the installation of a motor generator set or better, a mercury rectifier set. A mercury rectifier set is preferable for it works at an efficiency of 93 per cent. and 97 per cent. against an efficiency of 70 per cent. to 80 per cent. for the motor generator set. The upkeep of such a rectifier, however, is against it, as there is an expenditure of \$30 to \$40 per annum for bulbs, the life of a bulb being 800 to 1,200 hours, whereas, with a motor generator set, neglecting burn-outs, etc., there is no direct outlay.

For incandescent lighting the two currents are interchangeable. Upon observing minutely a lamp burning on 25 cycle current one can detect a flickering, which is absent in a lamp burning on 60 cycle current. This flickering is generally considered to be so slight as to be harmless to the eye.

Motors designed for 25 cycles do as good work as those designed for 60 cycles, the former, however, being more expensive, owing to the fact that more iron and copper are necessary. The no-load speeds obtainable with 25 cycle motors are 1,500, 750, 500, 375, etc., r. p.m., while those with 60 cycle motors are 3,600, 1800, 1,200, 900, etc., r.p.m., downwards. Thus, we see in the case where a direct connected motor generat.

or is essential or where there is a direct connected tool, the highest permissible speed with 25 cycles is 1,500 r.p.m., which may or may not fill the requirements. Where connection is made by means of belt and pulleys any diffi-

culties of this nature can be eliminated by varying the sizes of the pulleys.

Then to sum up:—power alternating at the rate of 25 cycles per second, is much more cheaply transmitted and distributed than power alternating at 60

cycles per second; to distribute at 25 cycles per second eliminates the use of frequency changer sets in the central stations; and with the exception of arc lamps one operates electrical appliances as well as the other.

The Machinery and Equipment of a Steel Suction Dredge

An Account of the Dredge under Construction in Toronto at the Polson Iron Works, for the Great Lakes Dredging Company, Port Arthur.

The large suction dredge built at the Polson Iron Works, Toronto for the Great Lakes Dredging Company, Port Arthur, is completed. The contract was divided between the Polson Iron Works and the Bucyrus Co., South Milwaukee, Wis., the former company doing the greater portion of the work.

The vessel, Fig. 1, is of steel construction throughout. In length, it is 125 feet, with a 40 ft. beam, and the main hull is 9 feet deep, will draw, when completed, about 5 ft. 6 in. of water. This main hull has been divided into two longitudinal, and three transverse, water tight bulk heads, making 12 water tight compartments. This precaution has been taken to prevent sinking of vessel in case of accident to shell, as two, or three compartments might be filled and the dredge still remain afloat.

The main deck house is 96 ft. long by 32 ft. wide, and is 9 ft. in height. In this and the main hold, are all the power mechanisms of the boat. On the forward part of the roof of this main deck house (not completed when photograph was taken), is the operating cabin, behind which is a steel house 40 ft. x 22 ft., for the living quarters of the crew.

Cutter Head.

The cutter head is a single open hearth steel casting, 5 ft. 10 in. in diameter by

4 ft. 8 in. long, and consists of eight extra heavy blades, radially set from a hub at the end and running back spirally to a 3 in. by 8½ in. back ring to which they are cast. This cutter head is mounted on a forged steel shaft, rough turned between bearings.

The cutter shaft is driven through three sets of gears by a 10 x 14 horizontal, double reversing steam engine, in the hold of the dredge.

The suction ladder shown in Fig 1 at A is 57 ft. long and 16 ft. wide at the inner end, tapering to the cutter head, and is of exceptionally heavy design consisting essentially of two heavy plate girders strongly cross-braced. The ladder is supported at its inner end by two trunnion bearings, one of which is hollow, and forms the suction pipe connection to the pumps. These trunnion bearings have removable caps, so that the ladder may be completely removed without disturbing the rest of the machinery. The ladder is suspended from a structural steel jib which in turn is suspended from a structural steel A-frame (the latter shown at B, Fig. 1), both of which are pin-connected to the deck. The hoisting tackle consists of a continuous rope with two leads to the drum, thereby equalizing the strains on the sides of the block. The lower block is so ar-

ranged that it is always out of the water, even in the ladder's lowest position.

Suction and Discharge.

The inboard suction and discharge pipes consist of 20 in. diameter, lap-welded, steel pipe, ½ in. thick, connected to the pump by steel casting reducers. To insure safety from sinking in case the discharge pipe should become ruptured, the latter is jacketted. All elbows in both suction and discharge pipes are open hearth steel castings, and are provided with man-holes for the ready removal of obstructions such as stones and stumps.

The centrifugal pump, Fig. 2, which is unlined, has a 78 inch diameter runner. Both suction and discharge orifices are the same in size, 22 inches in diameter. The casing is a single open hearth nickel-chrome steel casting, with the maximum thickness in the region of the greatest wear, and it is braced by radial ribs extending around the shell from the suction head flange to the similar flange on the back. As these ribs increase the thickness of the shell available for wear, the life of the casing is increased. The front and back heads, which are also unlined, are steel castings. The back head has brackets cast on to be attached to the base to which the pump shaft bearings are attached. The runner is a single



Fig. 1.—The Dredge Shuniah Before Launching, Polson Iron Works, Toronto.

steel casting of shrouded type with five curved arms. The pump shaft is made in two parts to facilitate the removal of the runner from the casing when so desired. These shaft parts are connected by large clamp couplings. The sec-

ladder. These are so arranged that any drum can be removed without disturbing the rest of the machinery. The spuds are lifted by two parts of rope, enabling them to be rapidly manipulated when stepping ahead. They are circular in

columns. There are two drums 42 in. diameter and 23 ft. 6 in. long, and 278 $3\frac{1}{2}$ in. tubes, 18 ft. long. The 7 ft. x 7 ft. grate is fed by a Murphy automatic stoker, and is supplied with forced draft from a Sturtevant No. 7 multivane fan.

The controlling arrangement is well arranged, for all the winch drum brakes and clutches, and the various engine valves, are all controlled from the cabin in the bow of the dredge, by compressed air supplied from an 11 in. Westinghouse air compressor.

Similar dredges have excavated successfully cemented gravel, hard pan, shale, and boulders as large as would pass the pump passages, without injury to the machinery. The average output in fair digging has been 250,000 yards per month. Recently one of these machines excavated 24,600 yards in 20 hours, or at the rate of 1,230 yards per hour.

Fig. 3 shows the dredge being launched. The overhead crane shows one of the features made use of by the Polson Iron Works in the handling of their large jobs. This crane runs the length of their erection yard, so can take care of the work for several vessels while under erection. Large shear legs, not shown in view, handle the material after the vessel is launched.

tion of the shaft next to the engine has three integral thrust collars with adjustable thrust bearings of the horse-shoe type.

Engine and Pumps.

The pump is directly connected through this shaft to a vertical triple expansion marine type, non-reversing engine, Fig. 2, with cylinders 15 in., 22 in. and 36 in. in diameter and an 18 in. stroke, capable of running 200 r.p.m., and of developing 700 i.h.p. at that speed with 190 lbs. steam. This engine was supplied by the Marine Iron Works, Chicago.

A 500 h.p. National Feed Water Heater supplies the boiler with water through two $7\frac{1}{2}$ x5x6 Blake Duplex feed pumps, working against a boiler pressure of 200 lbs. The Polson surface condenser used consists of a shell 36 inches diameter and 10 feet long, with brass tube sheets and tubes, presenting a total cooling surface of 1,200 sq. ft. A 14x16x18x13 Blake combined circulating and air pump meets the requirements of this condenser.

The electric light equipment consists of a 15 k.w. Sturtevant turbo generator set, with the necessary switchboard and connections. This supplies 180 16-c.p. lights, as well as a 14 in. search light mounted on the operating cabin.

The steam piping throughout is of solid drawn steel with cast steel flanges shrunk on. All other small pipe connections are of the usual wrought iron type with malleable fittings. All valves up to 2 in. are of brass, while those above 2 in. are cast iron with brass seats.

Winch Machinery.

The winch machinery consists of five drums operated from a double 8x10 steam engine. Two of these drums are for swinging lines, two for spud lines, and one for raising and lowering the

sections and are held in steel casting guides with hinged caps to facilitate shipping and unshipping. The steel casting spud points are especially designed to penetrate stiff material.

A 500 h.p. Heine water tube boiler, carrying 200 lbs. pressure, supplies the necessary steam. The boiler is similar to that used in stationary practice, except that it is encased in steel and is supported by heavy channel girders and



Fig. 3.—Launching New Dredge at Polson Iron Works, Toronto.

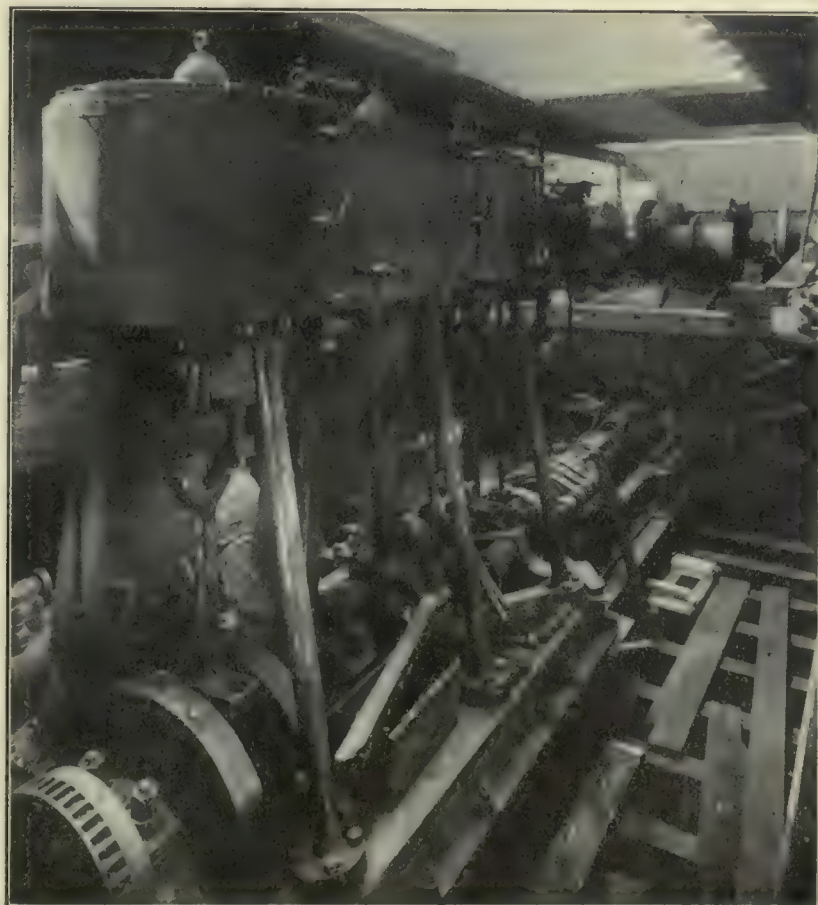

Fig. 2.—Machinery Equipment of the New Dredge Built at Polson Iron Works Toronto.

CANADIAN MACHINERY

AND MANUFACTURING NEWS

A monthly newspaper devoted to machinery and manufacturing interests mechanical and electrical trades, the foundry, technical progress, construction and improvement, and to all users of power developed from steam, gas, electricity, compressed air and water in Canada.

The MacLean Publishing Co., Limited

JOHN BAYNE MACLEAN, President **W. L. EDMONDS, Vice-President**
H. V. TYRRELL, Toronto **Business Manager**
G. C. KEITH, M.E., B.Sc., Toronto **Managing Editor**
F. C. D. WILKES, B.Sc., Montreal **Associate Editor**

OFFICES:

CANADA	UNITED STATES
MONTREAL Rooms 701-702 Eastern Townships Bank Bldg	NEW YORK - - R. B. Huestis
TORONTO 143-149 University Ave. Phone Main 7324	1109-1111 Lawyers' Title, Insurance and Trust Building
WINNIPEG , 511 Union Bank Building Phone 3723	Phone, 1111 Cortlandt
BRITISH COLUMBIA F. R. Munro	FRANCE
H. Hodgson, Vancouver	PARIS John F. Jones & Co.,
Room 21, Hartney Chambers	31bis, Faubourg Montmartre, Paris, France
GREAT BRITAIN	SWITZERLAND
LONDON - 88 Fleet Street, E.C. Phone Central 12960	ZURICH - - Louis Wolf
E. J. Dodd	Orell Fussli & Co.

Cable Address:

Macpubco, Toronto. Atsbek, London, Eng.

SUBSCRIPTION RATE.

Canada, United States, \$1.00, Great Britain, Australia and other colonies 4s. 6d., per year; other countries, \$1.50. Advertising rates on request.

Subscribers who are not receiving their paper regularly will confer a favor on us by letting us know. We should be notified at once of any change in address, giving both old and new.

Vol. VI. August, 1910 No. 8

ABOUT CATALOGUES.

Recently we received a letter from a subscriber in British Columbia regarding catalogues. He refers to certain manufacturers advertising in trade and technical publications that their catalogue will be sent forward if the request is written on the company's letter head.

The correspondent writes: "I find from experience that it is the working engineer who wants the information about the articles and how to operate them. Sometimes the catalogue is mailed inside the box with the article and is destroyed by grease and nails."

Catalogues should be widely distributed and both engineer and company supplied with a copy. Our correspondent in his letter writes: "The firms who print advertisements and catalogues and lock them up in the safe will find it mighty hard to get their wares to leave the warehouse. I am pleased to know there are some firms who agree with me and send engineers, the men who use the apparatus, particulars of their wares.

"I know several firms who send traveling mechanics around to those establishments where their goods are used, to see that the mechanics and foremen understand them. They see that the apparatus works properly, give instructions, catalogues, etc."

Our correspondent in attempting to hit one nail on the head has struck two nails squarely on their heads. The companies wish to get in touch with the mechanic and the mechanic wishes to procure literature in regard to machinery. For the informations of the manufacturer with the catalogues we could read him the parable of the sower. Suffice it to say, however, that if the catalogues and information is not distributed, he will be the loser.

Then, again, there are mechanics who do not avail themselves of the opportunity to procure information about apparatus on the market. In addition to reading carefully his technical paper, he should send for the catalogues that are procurable. A great number of companies, we are glad to say, will willingly send catalogues on request and mechanics can become well informed on the various power equipments on the market.

CANADA'S GROWING TRADE.

The total trade of Canada for June was \$66,000,000, an increase of \$10,354,623 over June of 1909. For the first quarter of the present fiscal year the total trade has been \$171,173,690, a comparative increase of \$36,606,000, or over 25 per cent.

Imports for June totalled \$39,705,237, an increase of \$8,363,675 over June of last year. For the three months imports totalled \$109,384,187, an increase of \$27,281,997. Exports of domestic products for the quarter totalled \$57,648,937, an increase of \$8,321,933.

The principal increase in exports was in agricultural products, which show a betterment of nearly six millions, as compared with the corresponding period of last year. The customs revenue for June was \$5,866,906, and for the three months, \$16,568,411, increases of \$1,004,647 and \$3,675,352 respectively.

SIGNS ON FACTORIES.

There are many ways of advertising a business, one important way being a sign in a prominent place on a manufacturing plant. This method is especially valuable if near a railroad or waterway. This method should be followed to acquaint the traveling public with the name and nature of the business.

Some large manufacturers neglect this form of advertising and they are often losers on that account. A traveler on a railroad is often prompted to ask what industry is located in certain buildings along the railroad. If there were a large sign, his question would be answered at once.

Then a conspicuous sign is a time-saver. A traveller or a customer visits a new place to select new equipment. There are a number of plants and he loses valuable time finding the one he wishes to visit. If he has only a short time between trains, every minute is valuable.

Then there is another viewpoint, the ethical courtesy. Be sure, Mr. Manufacturer, you will some day, if you haven't already done so, appreciate the courtesy of other manufacturers erecting an artistic sign in a prominent place. A sign is a good investment, which gives an air of prosperity to a plant and in addition is an excellent advertisement to the traveling public.

SECURING GREATER EFFICIENCY.

Black stained woodwork and furniture with dull terra-cotta red wall surfaces, the secretary of one company selected as the color scheme for a factory office, lighted on north and south sides by what practically amounts to glass walls, so great is the window area. The color combination is unique but the results are excellent. There is no reflected glare from the furniture.

All stock articles for which there is much demand are placed near the counters in one stockroom, to save time in filling orders. Those for which there is only occasional call are placed in the rear and away from doors. This, one manager finds, saves a lot of unnecessary handling.

25 CYCLE vs. 60 CYCLE.

Elsewhere in this issue is an article on "Power at 25 cycle versus 60 cycle in Toronto." This article treats on a subject that is of considerable interest at present due to most of the Western Ontario municipalities taking Hydro-Electric power from the Commission, all of which is transmitted at 25 cycle. The conditions prevailing in Toronto being necessarily much the same as elsewhere, the article is of general interest.

Mr. Gulley is in a position to be quite conversant with the conditions as they prevail, being in charge of part of the change-over from the 60 to 25 cycle in Toronto, so that what he states may be looked upon as authoritative.

As mentioned in this article, it is only profitable to change-over where the power users are scattered, as otherwise the cost of the change would be prohibitive, the saving where the transmission distance is short not warranting the extra expenditure of replacing the machine. For that reason, in Toronto, change-overs are only being made east of the Don, and in Parkdale, as in these districts, the industries are scattered. Similar changes have been made in other Western Ontario cities, the power companies changing over, and thereby compelling the power users to change their equipment to suit.

Mr. Gulley shows conclusively that it is much to the advantage of the operating companies to transmit at the lower frequencies, the figures he cites proving his statements.

This article will prove of interest to the majority of our readers, for it does not appear to be generally understood why this general change-over is being made.

LET US AVOID HYPOCRISY.

The extra-provincial tax of British Columbia is a menace to inter-provincial trade. There is no doubt about it, and no one denies it.

It is a sort of McKinley Act levied against the other provinces composing the Dominion.

But while this is true, do not let us who live and do business outside British Columbia play the hypocrite. These British Columbians may be sinners greater than we are in this one respect, but none of us can lay claim to being altogether free from narrow provincial legislative sins of the type which has been placed upon the statute book of British Columbia.

Several of the provinces have rather drastic laws on their statute books in regard to extra-provincial companies. In Ontario, for example, the penalty for non-registration is the same as in British Columbia, namely, \$50 a day for the company and \$20 a day for the agent or representative. And then some that have not extra-provincial taxes, permit municipalities to levy taxes upon commercial travelers, which is even a more irksome form of taxation.

Wherein the British Columbia Act chiefly differs from similar Acts on the statute books of Ontario, Quebec and Manitoba is in its enforcement. British Columbia seems determined to strictly enforce the law; the other provinces that possess a similar law are in the main unconcerned about its enforcement. The Vancouver Board of Trade has failed to induce the Attorney-General to suspend the operations of the Act for even six months.

The enforcement of the law will certainly interfere with trade relations between British Columbia and the other provinces.

But the tax of \$25 to \$250, according to the capital stock of the company, is not the worst feature of the legislation. It is its narrow provincialism that is most to be deprecated.

It is nationalism, not provincialism, which should be the aim of every Canadian to develop.

A law which, according to the Attorney-General's own word, declares it to be illegal for a person in British Columbia to order goods from a non-registered company located outside the province, certainly does not savor of nationalism.

Before, however, the business men of eastern Canada seriously undertake the modification of the objectionable British Columbia Act, would it not be well for them to begin at home? Their laws, in practice, may not be as aggressive as that in British Columbia, but they are on the statute book, and as long as they are thereon they can scarcely, with clear consciences, undertake the regeneration of their fellow sinners in the Pacific Province.

BAN ON THE SECRET REBATER.

The secret rebater is becoming more and more unpopular, and it begins to look as if Canadian salesmen were to be divided into two great moral classes—the secret rebater and the honest salesman who depends upon his ability.

The man who stoops so low as to offer a rebate in order to cover up his lack of salesmanship does not deserve the support or glad hand of his fellow traveler. His competition is most unfair; not only that, it is criminal in the eyes of the law.

Recent cases have come to our observation where travelers have declined to recognize their confreres on the street because the latter have been guilty of an offence of the criminal code in respect to secret rebates.

Under ordinary circumstances their action in keeping aloof from their competitors should be discouraged. But in the case at hand are they not justified to a certain extent in ostracising them?

The secret rebater is rapidly becoming unpopular, and rightly so. Business should be done on honest principles—a salesman should rely on his salesmanship ability, the standard of his goods, and the reliability of his house, and not on rebates contrary to the criminal, as well as to the moral law.

A large machine tool company used large quantities of cutting and threading oil in their screw machine and turret lathe departments, buying in barrel and carload lots. It was suggested that they could save money by purchasing their oil in tank car lots and compounding it themselves. A series of tests was conducted with varying proportions of different oil, different prices, and so on. The result showed to their satisfaction where by so doing an oil equal in quality to what they had been using could be had at such a reduction in price as to result in a saving of from six thousand to seven thousand per year.

FOUNDRY PRACTICE AND EQUIPMENT

Practical Articles for Canadian Foundrymen and Pattern Makers, and
News of Foundrymen's and Allied Associations. Contributions Invited.

FOUNDRY EFFICIENCY.*

By Benj. D. Fuller, Cleveland, O.

The question of raising the efficiency of the shop is ever a live one, be it the machine, pattern, smith, boiler shop or foundry. Hence, I feel it will not be trespassing upon the time of this body to ask you to devote a few minutes to the consideration of methods which have been tried and, so far, proven successful.

First, consider the question of excess weight on castings due to careless ramming, weak flasks and loose bars, weak boards, soft pit walls, etc. What does it mean? Not only a poor casting, but an expensive one in many ways. If it be a small casting, say one properly weighing 5 lbs., the order calling for the delivery of 1,000 daily, and you produce one thousand castings which, due to some negligence, average $5\frac{1}{2}$ lbs., then the day's work shows 500 lbs. excess weight at .008 per lb., equals \$4 per day for the one pattern, iron cost only. Now while the foundry will probably receive credit for the extra weight, it means a loss, however, to the company, who charge a certain figure for the finished equipment.

Another loss is in machinery, as jigs will not fit properly, etc., and when your foundries are in one city, and your machine shops in another, there is the extra freight charge from foundry to factory, and again the extra freight charge when shipping the finished equipment. If the casting is a heavy one, such as an engine or generator bed, armature, spider, field frame, etc., something weighing 15 to 40 tons, the case is more marked, a variance of 1,000 lbs. or more in two castings from the same pattern is not extraordinary. This, when your freight shipments are thousands of tons monthly, means much.

Now awaken a live interest in this question in your foremen, and the result is not only a saving in dollars and cents, but the satisfaction of noting a marked improvement in the quality of output. In our case a card record of shipments by pattern number is kept, upon which card weights are recorded as separate shipments are made. When gains or losses show, the case is tabulated in a monthly report, which is totaled at the close of the month, each foreman's department being segregated.

Many disagreeable surprises are in

store for any one compiling such a report, but when the foremen are gathered to discuss the question, and marked cases are brought to their attention, it "sinks in," with the result that, as in our case, it shows a decided total gain.

Following up this matter has also emphasized the advantage of the molding machine, as invariably the transfer from hand to machine molding shows a decided gain in quality, as well as reduction in weight. This may not appeal to the man who sells his castings by weight, but it will appeal to his customer from both standpoints.

A striving to improve a record among the foremen, must needs awaken an ambition among the men, and nothing is better for the shop than to get the men interested in a sort of contest of this kind.

Another method being employed, and which promises well, is an efficiency record, whereby a report is tabulated daily showing the amount cast in pounds by each man, the amount good and amount bad. The per cent. of scrap made in each department, or bay, in a given period, usually from one pay to another, and whether a man is over or under the average of his bay for this period.

A foreman's record is determined by the average of all the men working under him. This individual record is kept by card index, so that any man may be shown up at any time. No bluff as to "how good you have been" can be carried out in the face of this record. And on the other hand, the deserving can be singled out. This card record is of considerable value when men ask for advance in rate from time to time. By a glance it is easy to determine a man's comparative value. For instance, if a man's record shows that he has made more scrap than the average of his department, you would not waste much time in argument with him.

Copies handed to each foreman of a daily tabulated report showing the number of castings made from each pattern, and the number which were defective, in a parallel column for comparison, will also "help some."

The coremaker is also kept tab upon, and opportunities afforded the ambitious, as well as means used to stir ambition among the men and boys. Here is a method of handling the yard labor, such as loading and unloading cars, piling and transporting stock, iron, scrap, coal, sand, limestone, clay, etc. If you have kept a record whereby each opera-

tion has been segregated as to cost, it is an easy matter to strike an average as to the cost of the whole, using as a base the average cost per ton to you at present, or the best figure you have recorded. Offer a good man in charge of the whole yard force a premium for every fraction of a penny per ton he can beat this record price. Do the same with the cupola operator as to the costs which enter into his work, charging coke, iron scrap, ladle and cupola care, etc., etc. The same with the man responsible for the cleaning and chipping of the castings, and you may be surprised at the results.

Do not make a move which will weaken the men's confidence in your fairness, and in the words of the immortal Abe Lincoln, "There may be other things which your special case requires to make you happy, but, my friends, these, I reckon, will give you a good lift."

FOUNDRY ECONOMIES.

By K. Campbell.

In a recent issue reference was made to a number of saving in the factory of the National Cash Register Co., Toronto, by which resulted in \$11,400 being saved annually. The attention of the superintendent has also been given to the foundry department where a number of savings have been made.

After the brass castings came from the foundry and the gates were removed, they were brushed and afterwards dipped in an acid solution, in order to thoroughly cleanse them before they were machined. It was suggested that by using a heavier brush, the castings could be so thoroughly cleaned that the dipping process would be unnecessary. This suggestion has been tried out and works satisfactorily. As a result \$565 per annum will be saved.

Another big saving was made in the foundry by subdividing the work so that the high priced molders do nothing but mold, while the clamping of molds and other similar work is done by cheaper men.

The increase of work made it necessary to get more floor space in the foundry. This was done by substituting for the coke drying stoves, gas heated stoves which take up one quarter floor space, and also by eliminating the smoking process without hurting quality of castings and thus doing away with several smoke boxes.

* Read at A. F. A. Convention, Detroit.

The Molding Machine in the Machine Tool Foundry

Actual Examples of What is Being Done in this Field of Development—Product Improved and Cost Reduced—An Assistance to the Skilled Molder.

By John Edgar.

The high quality of castings that are now required by machine tool manufacturers has forced the foundrymen to pay particular attention to the finish of the molds in order to meet these requirements. When one takes into consideration the complexity of the modern ma-

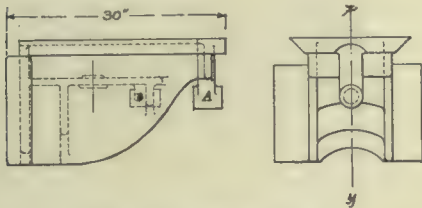

Fig. 1.—Drawing of Knee.

chine tool with its gear boxes and box-sections, we may credit the foundry with real progress in being able under these conditions to cope so successfully with their problem.

In the March, 1909, issue of Canadian Machinery we described the method of molding pulleys on the molding machine; and in this issue some more representative examples of machine tool work will be shown.

As was mentioned in the above article the greatest drawback to the production of first-class castings was the tearing of the molds in drawing the patterns. Not only in the finished product do these torn molds show up badly, they also appear to considerable disadvantage in the cost of the castings. As the use of the molding machine eliminates

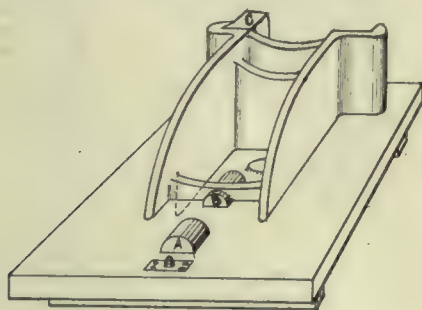

Fig. 2.—Cope Pattern Board.

these 'tears' it has a double advantage either one of which would offset any disadvantage that one may find.

One type of machine used on this class of work employs stripper plates to prevent the tearing of the molds. These stripper plates are made to conform to the shape of the pattern at the parting and the pattern is drawn

back into the former position, ready to receive another flask. During the drawing and just before it is commenced the frame is struck a few sharp blows with a rawhide hammer to free the pattern from the sand. Air vibrators are also used for this purpose, and where air is available are preferable.

This type of machine is very expensive to fit up and is only available when one pattern is to be worked continually. But in machine tool work where castings are desired in limited quantities the hand ramming roll over type of machine in which the ordinary split pattern is used is the most useful.

The reason the hand ramming feature is more desirable than the power squeezer type is due to the fact that the many pockets formed by the irregular shape of many machine tool patterns makes it difficult to obtain an evenly rammed mold. In this type of machine we have the desirable features of both hand and machine molding combined.

This is the style of machine that was used in molding the pulleys, described in

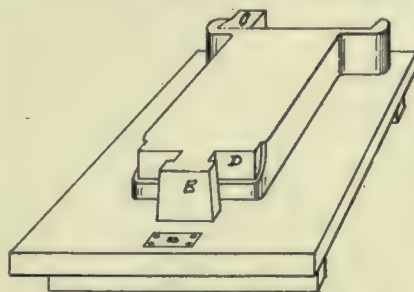

Fig. 3.—Check Pattern Board.

the March number. The operation is as follows: The pattern is attached to the board that is fastened to the roll over the frame of the machine. By means of guides the frame has a straight line drawing action, operated either by hand or air or hydraulic power. The pattern board is clamped to the rollover frame of the machine in a position such that the pattern faces upward. The flask is then set upon the board to which it is held by fixed dowels. Sand is rammed into the flask around the pattern, as in ordinary molding, the molder striking it off flush with the top of the flask. Then a bottom board is clamped to the top of the flask and pattern board so that they are held firmly during the rolling over operation, which is next in order. When the frame has been rolled over into the opposite position the clamps

are removed and the frame, carrying the pattern board with it, is raised vertically until the pattern is free from the sand. At this point the frame is rolled through them when drawn from the sand. The plate prevents any sand clinging to the pattern.

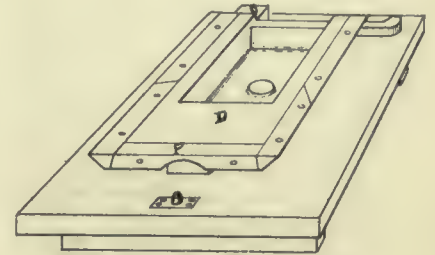

Fig. 4.—Nowel Pattern Board.

As examples of what has been done on these machines, in the way of medium heavy work, illustrations are taken of two castings that have been successfully molded on the molding machine at a great saving in time, with a considerable advantage in the matter of the appearance of the product.

Open Type Knee.

The first example is an open type knee shown in Fig. 1. This pattern was originally molded in a two part flask. In adapting it to the molding machine, a three-part mold had to be used on account of the limit in the range of the machine. The partings were made, one horizontally through the centre of the bosses A and B, on the outside, and in the inside between the boss B and the back of knee, the parting was made at the shelf. This pattern was attached to

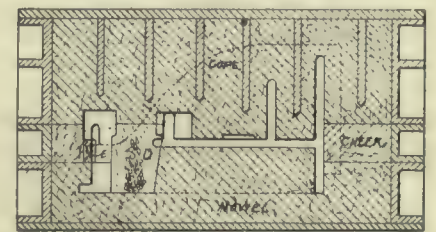

Fig. 5.—Set up of Mold for Knee.

the board along the outside parting line and the deeper parting inside was cut into the board as shown in Fig. 2 which is a perspective view of the pattern and board. The angle in the slide at the back is cored out, the print showing at c.

That part of the knee above the centre of the bosses A and B and up

to within a couple of inches of the top, where the other parting was made is shown in the view in Fig. 3. In drawing this pattern from the mold the inner boss on A and the outer one on B would interfere unless they were made loose. Loose pieces are features that must be avoided in machine molding, if possible, and in order to do so in this case a core is inserted between the two bosses, running to the board, and one is also placed

each foundryman has a way of arranging them to suit his own ideas and experience, it is not necessary to go into the details of the mold in that direction.

Much of the success in machine molding depends primarily on the pattern and unless care is taken with the draft it cannot be drawn freely from the mold. In machine molding the pattern is confined to a straight line motion vertically and cannot be shifted laterally to favor

which was for a 12" draw. So they split on the X Y centre line and molded sideways; the inside of the knee being taken in a dry sand core.

Molding Machine Leg.

Fig. 6 shows another job of molding that caused considerable trouble when made by hand. This is a machine leg with an oil reservoir inside, and a drip pan as shown. As first constructed this pattern was made to be molded upside down, the inside being cored out with a dry sand core. The depth of this mold and the effect of the core caused the casting to be very badly distorted and the walls came very much thicker than the pattern intended.

A new pattern was eventually made split on the vertical X Y axis and better results were obtained. This pattern was fitted to the pattern boards of the molding machine, as shown in Figs. 7 and 8. Fig. 7 shows the plain side of the pattern, while Fig. 8 shows the side with the projecting drip pan. This pan was the cause of some apprehension when the job was first tackled, but some little thought on the problem resulted in making the pan loose, as originally molded, which made it necessary to draw it by hand after the main part attached to the board had been drawn off. By this method it was possible to use a machine of smaller range and worked out successfully in practice. A, which is the main core, was supported in the mold on chaplets, at the bottom, as shown in Fig. 9. The core B in the pan is wired to the flask to hold it in position.

This job taxed the machine to its full capacity and the pattern could not be drawn wholly from the sand by the straight-line action of the machine, but recourse had to be made to the rolling over action as well in drawing the pat-

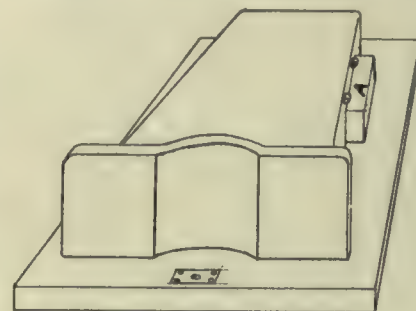

Fig. 7.—Cope Pattern Board.

under the outer boss of A for the same purpose. These cores are shown in Fig. 3 at D and E. The core D is run to the middle of the outside walls of the knee in order to preserve the rounded edge.

The rest of the mold is made up of that portion of the knee above the second parting, and the pattern and board are shown in Fig. 4. In this pattern the core D runs up flush with the top of the slide. The angles or dovetails, and also the front ledge F, are made loose, it being considered better to avoid cores that come in contact with surfaces to be planed because the tendency is to chill the iron and cause a hard gritty scale which acts injuriously on the tools. These loose pieces are held in place while ramming the sand around them by draw pins or dowels, which are removed before drawing the pattern. In order to mold the top of the shelf the board is cut out to the proper depth and the boss placed in position.

Fig. 5 shows how the three parts, match up to form the mold. The mold is poured with the face of the top slide downward, as this ensures a good clean surface free from sponginess and dirt. The dirt generally rises in the mold and any surfaces that are horizontally placed and facing downward catch it as it rises with the iron. Pouring heads and risers are not shown in this sketch as they are of the ordinary design and, as

any irregularities in draft. In fact where it is possible the draft must be of a greater degree than that used in hand molded patterns. Patterns are not as a rule given sufficient draft for easy molding and this lack of sufficient draft is the cause of much of the tearing and the waste of valuable time mending the molds, as a result.

Not only should every surface of the pattern be made with a good draft, but the core prints, where they are to be drawn from the sand and where they fit into one another should be provided with a good angle of bevel. The making of cores with right angular sides causes a great deal of trouble to the core setter, who is forced to file the cores to make them fit. Pattern makers do not seem to be able to comprehend the fact that cores are made of sand and are liable to variations. A core that has to be filed to get it into the space intended for it cannot very well be expected to match up with the rest of the mold and must necessarily result in a jog at the parting.

Referring again to Fig. 1, it may be well to mention the manner in which the larger sizes of these knees were fitted for the machine. In these sizes it was impossible to part them, so as to mold as has been described, which description refers to the smaller sizes. This was due to the limited range of the machines

tern. As the rolling over occurs at a fairly good radius from the pivot, and the pivot is so located on the machines used that the rolling over is practically equivalent to a straight draw for a couple of inches or so. By taking this into consideration a good job was event-

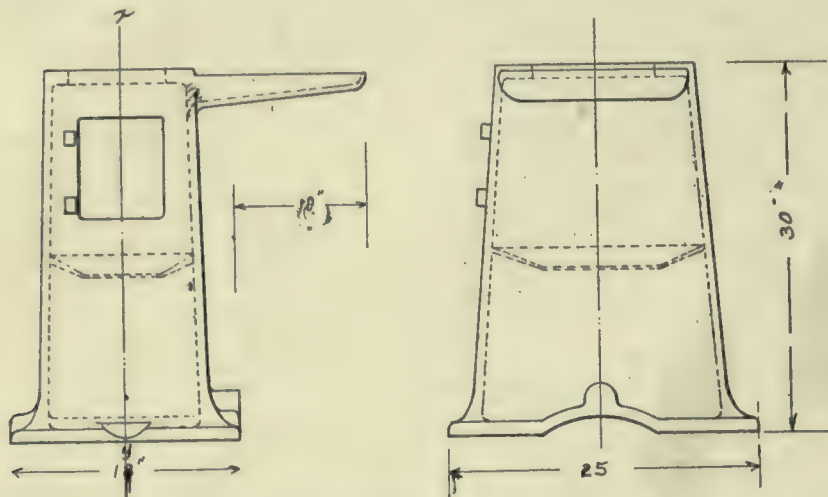

Fig. 6.—Drawing of Cabinet Leg.

ually made of an otherwise difficult one. The castings resulting—after the usual amount of experimenting—were of the highest order and were beauties compared to the hand molded product.

These two examples are only averages in the great variety that can be handled on the molding machine of the roll over type.

Many foundry masters look upon the molding machine only as a means of sub-

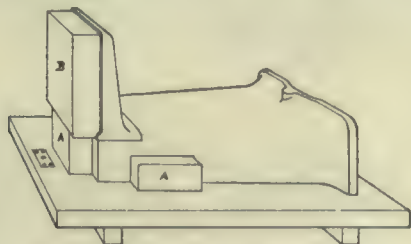

Fig. 8.—Nowel Pattern Board for Leg.

stituting cheap for skilled labor. Such a view of the matter is obviously short-sighted, for while cheap labor can be employed to a greater extent in connection with machine molding it cannot replace skilled labor exclusively. On the other hand the molder is liable also to look upon the matter short-sightedly, and to regard it as a means that will eventually deprive him of a job. Such is not the case. That a molder skilled in making the molds in the ordinary way by hand, can prove a success on the machine is only an impossibility to those that regard the advent of labor saving machinery in the old fashioned narrow manner.

The examples shown above were all handled by unskilled hands, that is, by laborers, who after a few weeks train-

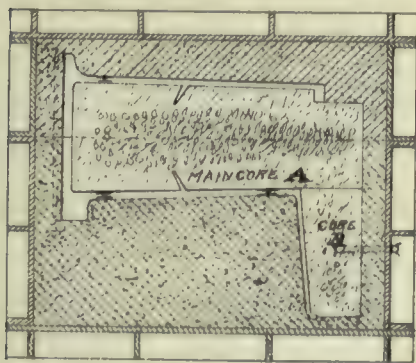

Fig. 9.—Setup of Mold for Cabinet Leg.

ing in the use of the tamper or rammer were turning out very creditable work. Their introduction into the foundry of this particular shop was forced upon the management, as even the use of the machines themselves was by trouble with the molders. Their introduction was a revelation in the possible reduction of

cost and time in the production of high grade castings. To be sure, there was a great deal of loss from bad molding and the percentage was larger than seemed necessary, but after things settled down, and the excitement of breaking in a new crew and the rush from the call for castings from the machine shop was eased up—for all this occurred during the great business boom of two years ago—the percentage of bad castings was gradually reduced so that the foundry could show, not only a great saving in both time and labor cost, but a comparatively large order for castings could be turned out in a short time. In fact the foundry—as business became nearer normal—was soon running ahead.

What results could be obtained from the combination of the molder's skill and the good points of the machine can only be surmised, but, it is evident that they must be combined in this line in the very near future.

UNITED STATES AND CANADIAN FOUNDRIES.

A census of the foundry industry of the United States and Canada made by The Foundry shows a total of 6,594 foundries on April 1, 1910, against 6,366 in 1908, a net increase of 228. A similar census in 1906 showed 6,108, so that the net increase in four years is 486. In compiling the figures each plant was regarded as a unit, though there might be several departments. Counting each foundry department as a unit—there being many cases where gray iron and brass foundries are operated by one company, sometimes with a connected malleable or steel foundry—the total for the United States and Canada is 9,158. The total number of foundries producing gray iron castings is 5,157, as compared with 5,105 in 1908 and 4,956 in 1906. The plants melting non-ferrous metals exclusively, including brass, bronze, aluminum, etc., number 1,240, against 1,096 in 1908, an increase of 144. Brass foundries operated as departments of works number 2,318, making the total number of brass foundry operations 3,558. The number of foundries making castings into which aluminum enters is found to be 1,879. The increase in malleable and steel foundries is noteworthy. The total number of malleable castings plants is now 178, of which 168 are in the United States. The total for the United States and Canada in 1908 was 153. The number of steel foundries is 265, against 211 two years ago.

HAD TO READ MACLEAN PAPERS.

J. E. Brown, manager of the wholesale department of Revillon Bros., Ltd., Edmonton, Alberta, paid a compliment

to the MacLean newspapers recently, saying that they were amongst the brightest publications of the kind that came to his desk.

"I am a great believer in trade and technical newspapers," said Mr. Brown. "Previous to my coming to Canada, I was manager of a large mercantile house in the United States. We subscribed to some 35 of the best trade newspapers of America. I read them religiously myself and I had a system whereby the whole staff did the same, a regular circulating library. Each employe was expected to read and initial each paper in turn. If I found a member of the staff neglecting this duty he was called into my office and remonstrated with. I considered those who read these newspapers made the best men and I wanted my staff to get all the education they could out of them. The best talent in the country contribute to good technical and trade newspapers and time is well spent in reading articles calculated to sharpen a man's instincts and keep him posted."

Machines last longer in one manager's factory cared for by two men who were responsible for repairs.

The color of the order card in one brass foundry indicates the grade of metal to be used in casting small parts.

A master molding machine is kept as sample in the pattern room of one factory, and all repairs on the molding machines are made in accordance with it.

Factory forms in one plant are padded at the printers. This saves much waste. By buying large quantities the extra cost of padding is negligible.

The manager of a plant consisting of several mills, has the superintendent of one plant visit the other. This man makes a report of what he sees that in his opinion might be changed to advantage. And the manager gets the advantage of a fresh point of view on the work.

A new factory telephone system, made up of nine telephones, installed at a total cost of two hundred and seventy-nine dollars, in a three-storey factory, during the first year saved enough time in the different departments to repay the company for installing the instruments.

A very successful lacquer and one easily prepared for covering brass is made by dissolving 17½ ounces of good brown shellac in one gallon of the best 95 degree alcohol, wood alcohol will not do. The brass should be clean, dry and heated when the lacquer is applied. The brass should not be so hot the lacquer will run off it. The lacquer should be cold and 3 or 4 coats applied with soft brush.—Factory.



The Large Foundry of the Aluminum Castings Co., Detroit.

Features of the World's Largest Aluminum Foundry

Layout is Arranged on the Unit System, there being Ten Units, Five of which are in Operation, Large Windows, Electric Cranes, Molding Machines, etc.

The automobile industry is responsible, to a great extent, for rapid developments in machine tools and foundry equipments.

Detroit is rapidly forging ahead as a leading foundry centre. It is now a great automobile centre. To keep pace with the growing automobile trade the Aluminum Castings Co., Detroit, have under erection the largest aluminum foundry in the world.

The foundry consists of ten units, five of which are now in service, and contains many valuable modern features. The layout of the foundry is unique, in that it is arranged on the unit system, each unit being practically a detached foundry, provided with its own core room and melting departments.

The entire plant is in charge of a superintendent, to whom the foremen of the various units are responsible. This system permits the classification of work, the light and heavy, large and small castings being each made in separate units. By this division of work the men become more efficient, and operation costs are curtailed.

During periods of limited demand the unit plan of operation permits the shutting down of any number of departments, thereby eliminating a large portion of the expense entailed in operating a large foundry on a limited output.

The entire plant, ten units, is 600x264 feet, and each unit is 60 feet wide. The melting furnaces are located in two lean-tos, 20 feet wide and 86 feet long, which are divided from each unit by a brick wall, making each melting department approximately 40 feet long. Extending through the centre of each

foundry is an industrial track which leads to a wide passageway running the length of the plant, and at right angles to the foundries and the core departments. A narrow gage track is laid through the centre of this passage, which communicates with the tracks in each of the units. This industrial railway system affords excellent transportation facilities throughout the plant, and is used for delivering sand, flasks and patterns to the various foundries, and for the shipment of the castings from these units to the cleaning department. The passage way also serves to separate the core rooms from the foundry units.

Grinding and Shipping Department.—The grinding and shipping departments are located in unit No. 1, and in the core room end are the pattern and machine shops.

The chipping is all done on one side of the shop, the pneumatic shippers taking their air from an overhead line extending the length of the building. On the opposite side is a band saw.

For cutting off gates, two motor-driven grinders are provided.

The castings, after the removal of the cores, are delivered to the department on cars operating over the industrial track system previously described.

Aluminum will be cast in the ten units, and in the additional sections to be added later the three Detroit brass foundries operated by the company will finally be consolidated.

The sand-preparing plant for the entire foundry is located in a basement extending partially under unit No. 1, the mixing machinery being located in

the basement underneath the pattern shop. A chute, covered with a grating, leads from the chipping department to the sand-preparing plant, and castings reaching the shipping department without the cores removed will be shaken out over the grating. The sand receiving track parallels the core room side of the foundry and the sand is unloaded from cars into chutes leading into the basement.

Core Department.—The core ovens are oil-fired and the fuel cost averages only from 7 to 10 cents per night for each oven. The white appearance of the cores is due to the core wash used, with which all of the cores are sprayed in place of coating them with plumbago. This gives the cored surface of the castings a very smooth finish, which is essential.

Melting Department.—The melting departments for each foundry are located in lean-tos on the end of the plant, opposite the core room. They are equipped with oil-fired, aluminum melting furnaces, and in addition, crucible melting furnaces are installed in each.

The air is delivered to the furnaces from an over-head main from the blower plant. The aluminum furnaces are simple in construction, being made of steel plate lined with fire brick. The cover handles are pivoted in the centre, which permits the covers to be swung aside when lading out the metal or charging. Each melting unit is provided with a metal storage locker, entirely enclosed with heavy wire netting, to which the melter only has access. This arrangement permits of keeping an accurate record of the metal used in each foundry unit.

INDUSTRIAL ^A_N^D CONSTRUCTION NEWS

Establishment or Enlargement of Factories, Mills, Power Plants, Etc.; Construction of Railways, Bridges, Etc.; Municipal Undertakings; Mining News.

Foundry and Machine Shop.

OTTAWA.—The Department of Agriculture have awarded the contract for the building of a quarantine steamer for the Immigration Department to the Kingston Shipbuilding Co. The steamer will be located at Grosse Island and will cost \$60,000.

WINNIPEG.—The National Transcontinental Railway Commission have awarded a number of important contracts for the workshops here. The Morgan Engineering Co., of Alliance, Ohio, secures the contract for one 140 ton electric traveling crane; Mussens, Ltd., Montreal, were awarded contracts for eleven electric (Proth) cranes; George Anderson & Co., Montreal, one five ton grey iron foundry crane, five hand power traveling cranes and 15 (Gib.) cranes, Whiting Foundry Equipment Co., Harvey, Ill., 20 (Gib) cranes and twenty foundry equipment cranes.

QUEBEC.—The Carnac-Marquis Glue Co. of this city, are making some important changes in their already well equipped factory. They are located at St. Malo and have decided to introduce electricity for their whole establishment, that is for operating purposes. The power will be supplied by the Quebec Railway Light & Power Co., and the machines by the Canadian Westinghouse Co.

ST LAMBERT, QUE.—The Monarch Electric Co. will build a manufacturing plant here providing the town council will grant exemption from taxes and also free water for twenty-one years.

WINDSOR.—The promoters of the Windsor steam laundry have abandoned their original plans and instead will start a shirt factory. The company will erect a \$40,000 plant here. Between 25 and 50 persons will be employed.

NEW TORONTO.—The Dominion Abrasive Co., being a combination of Canadian and American interests, have purchased two acres here on which is a solid brick factory from F. H. Ross & Co. They are manufacturing emery wheels.

ST. JOHN.—The Board of Trade Council, at a meeting held last month, discussed the application of James Pender, to the City Council for a fixed rate of taxation for his nail manufacturing plant for the next ten years, and heartily endorsed the idea. The treasury board of the council is to meet this week to consider the request, and it is generally believed that it will be granted. Mr. Pender in speaking of his plans, said that if the city will grant his request, he will double the capacity of his present factory. This would involve an initial expenditure of about \$50,000 or \$75,000, and would necessitate the employment of a large number of additional hands. He has definitely decided that he will not go west, as he had expected, but will stay in St. John, and devote all his energies to the promotion of trade with the Canadian West, and the far away portions of the empire.

ST. JOHN.—The contract for the erection of the new building for the New Brunswick Telephone Co., has been awarded to B. Mooney & Sons, of this city. The contract price is about \$22,000, and the building is to be ready March 1.

ST. JOHN.—Stanley E. Elkin, of the Maritime Nail Works, is one of those applying for incorporation as the Motor Car and Equipment Co., with a capital stock of \$24,000. They have begun the building of a garage, on Princess Street, and will carry on a general automobile business.

ST. LAMBERT, QUE.—The Parker Foundry Co. have purchased a large tract of land here and will erect a new foundry in the near future.

FARNHAM, QUE.—The Dominion Vault and

Safe Co., will locate here, and will employ from 100 to 400 men.

VANCOUVER.—The machinists of this city went out on strike on July 5, to enforce their demands for an eight-hour day and a minimum wage of 45 cents an hour. Their demand is in line with those of other coast cities, and some 600 machinists are affected between here and San Francisco, where the conditions demanded here exist. About 140 men are out in Vancouver, and the shops affected are the Mainland Iron Works, B.C. Marine Railways, Vancouver Engineering Works, Ross & Howard, Letson & Burpee, Terminal Iron Works, Pacific Ironworks. At New Westminster the men at the Schaake Machine Works are out to the number of 45, and their action affects about a hundred men in the works, part of the plant being shut down. They demand a reduction of working hours from 50 hours to 48 hours per week, starting at 7.30 a.m. and working until 5 o'clock, with an hour for lunch, for five days, and working from 7.30 o'clock to 1 o'clock on Saturday.

KAMLOOPS, B.C.—The contract for the new C.P.R. machine shop and roundhouse here has been awarded to McDermott and Co., Winnipeg. C.P.R. supply the steel. Estimated cost, \$250,000.

FORT WILLIAM.—Contracts for the erection of Grand Trunk Pacific roundhouse and machine shops on the Mission have been awarded to the Carter, Halls, Aldinger Co., to cost, \$100,000.

Robert Hobson, general manager of the Steel Company of Canada is authority for the statement that a majority of the stock of the Dominion Wire Mfg. Co., Montreal, had been acquired by the merger.

TORONTO.—Jules Motor Car Co., has been incorporated and will manufacture automobiles in Toronto.

WINNIPEG.—The Petrie Mfg. Co. will build a warehouse here to cost \$22,000.

MONTREAL.—The Universal Engineering and Mfg. Co., have been authorized by the Dominion Government to change their name to that of the "Universal Vacuum Cleaner Co."

TORONTO.—The Mason & Risch Piano Co. will build a six-storey building in this city.

TORONTO.—The Rice, Knight Co., Toronto, manufacturers of gasoline lighting systems, had a small loss by smoke and fire. It was covered by insurance.

OTTAWA.—The Laurentian Mica Company's premises on Bridge Street were gutted by fire on June 16. The loss is estimated at \$9,000, covered by insurance. About 175 girls are temporarily thrown out of employment.

HAMILTON.—The Canadian Shovel & Tool Co. announce that they will increase the size of their plant and install new machinery, enabling the output to be doubled.

VANCOUVER.—The Sullivan Fireproof Walls and Partition Co., of Canada, have established a factory here for the manufacture of gypsum and coke breeze fireproof bricks.

SASKATOON.—The Canadian Agricultural Motors Co., an institution which has been operating in Australia for the last few years, will erect a factory for the manufacture of gasoline engines and other motors which can be used in agricultural pursuits in this city.

Municipal Enterprises.

HULL.—Carriere & Wilson have been awarded the contract for the construction of the new sewer on Champlain Ave., for \$2,850.

OAKVILLE.—The town council will have T. A. Murray prepare plans for the sewerage disposal.

BARNABY, B. C.—The Brouse-Mitchell Co., Vancouver, have secured the contract for the construction of waterworks here.

TOFIELD.—The by-law to spend \$4,000 on preliminary work for waterworks was carried.

ESTEVAN.—Sealed tenders will be received by L. A. Duncan, secretary-treasurer, until 8 p.m., on Wednesday, August 24th, 1910, for the following works:—Contract "A"—Pipe-laying on storm sewers; contract "B"—Power house; contract "H"—Two return tubular boilers; contract "J"—High-speed steam engine; contract "K"—Electric lighting system; contract "S"—Sewer pipes. Plans and specifications may be seen at the office of the engineers, Chapman & Power, Winnipeg and Toronto, and at the town hall, Estevan.

BERLIN.—Tenders will be received by the undersigned up to August 1st, next, for a Compound Duplex Pumping Engine, capable of pumping two million imperial gallons per day, against a head of 125 pounds per square inch. A second hand pump will also be considered. For further information apply to H. Hymmen, Superintendent Berlin Waterworks.

WINDSOR.—It has been decided to purchase electric power from Niagara. The 110,000-volt line to London, Ontario, will be extended over the 108 miles separating Windsor from this city. The expense of building the line to the city limits will be paid for by the Ontario government. Windsor, which is a small town, cannot use more than 2,000 horsepower, but it has contracted to sell a large share to the city of Detroit, which is directly across the river. The power used in Detroit will thus be conducted over a distance of 220 miles from the point where it is generated.

WINNIPEG.—Sealed tenders on prescribed forms, addressed to the Chairman of the Board of Control, Winnipeg, Canada, and marked on the envelope "City of Winnipeg Electrical Distribution System, Tender for Cable," will be received at the office of the undersigned up to noon on Thursday, September 1st, 1910, for the manufacture, delivery and installation, 46,000 feet of thirteen thousand volt, three-core cable. Copies of the specifications and forms of tender may be obtained at the Power Engineer's Office Carnegie Library Building, Winnipeg. These specifications may also be examined at the offices of Messrs. Smith, Kerry and Chace, Confederation Life Building, Toronto, Ont., M. Peterson, secretary.

WINNIPEG.—The contract for supply of sewer pipe and junctions for this city has been awarded to W. F. Lee, Winnipeg, for \$20,120.25.

STEWART, B. C.—The Dominion government has granted \$20,000 towards the installation of a sewerage system here.

STETTTLER, ALTA.—The John Galt Engineering Co. have charge of the installation of the waterworks system here.

ST. BONIFACE, MAN.—A new waterworks system will be installed shortly at this place.

CHAUDIÈRE CURVE, QUE.—A. Leofred, C.E., has closed a contract with the town council at this place for a waterworks plant to cost when completed, \$250,000.

STRATHCONA, ALTA.—The contract for the sewer and water extensions at this place was awarded to Hulbert & Wilson at \$13,847.95.

VANCOUVER.—Macdougall & Co., of this city, have been awarded a contract for the construction of \$50,000 worth of sewers at Nanaimo, B.C.

LADYSMITH, B. C.—The town council have passed a by-law to raise \$25,000 to improve the waterworks system.

FERNIE, B. C.—J. J. Wood was awarded the contract for the construction of storm sewers at this place.

MONTREAL.—The Structural Steel Co., of this city, have been awarded the contract for the construction of an 80,000-gallon stand pipe for the municipality of Longueuil.

TORONTO.—The Board of Control have awarded the contract for the pipe for the 500-foot extension of the waterworks intake pipe to the Canada Foundry Co. The details of tender are: 72-inch steel riveted pipe, per foot—500-foot lot, \$19.98; 1,000-foot lot, \$19.22, 1,500-foot lot, \$19.00; branch for present intake, \$709; new intake branch, \$1,481; 3-steel flexible joints, each \$1,072.

VANCOUVER.—The waterworks branch of the Civic Works Department, is this year laying 100,000 feet of 6-inch pipe, 45,000 feet of 12-inch, 20,000 feet of 20-inch and 18,000 feet of 16-inch.

ST. JOHN.—The city council have awarded the contract for supplying 314 tons of cast iron pipe to the Stavely Coal & Iron Co., Chesterfield, Derbyshire, Eng. Their bid was as follows: 12 inch pipe, \$27.15; 10 inch, \$27.30; 8 inch, \$28.10; 6 inch, \$28.60. Others tenderers were: Camden Iron Works, Singleton, Dunn & Co., Watson Jack & Co., D. Y. Stewart & Co., Stanton Iron Works, United States Cast Iron Pipe & Foundry Co., Vroom & Arnold, T. McAvity & Sons and W. H. Thorne & Co.

PRINCE RUPERT.—S. P. McKord & Co., Victoria, have received a \$15,916 sewer construction contract for this city.

Electrical Notes.

ST. CATHARINES.—By-laws, giving the Buffalo, Niagara and Toronto Railway Co. and the Ontario Power Co. rights over city streets, were voted upon on July 29.

GRAND FALLS, N. B.—It is announced that arrangements have been completed between the Grand Falls Power Co. and Sir Wm. Van Horne and other owners of property by which the latter will take over the old company and develop power at the falls.

PRINCE ALBERT, SASK.—Goldie & McCulloch, of Galt, Ontario, obtained the contract for boilers for the electric light works here.

YORKTON, SASK.—The town council passed a resolution authorizing the preparation of a by-law to expend \$35,000 on a municipal electric light plant.

LONDON.—The Water Commissioners awarded the contract to the London Foundry Co. for 76 ornamental electric light poles at \$29 each. The Northern Electric Co., of Toronto, were given the contract for line hardware, amounting to \$1,700.

STRATHCONA.—A by-law to provide for raising \$10,000 for extension of the city's electric light and power system has been submitted to the ratepayers.

WELLAND.—The by-law to grant franchise to electric railway through the town was carried.

SEAFORD, ONT.—The town council has decided to submit a by-law to the people for the purpose of purchasing 400 horsepower electric current from the hydro-electric commission.

MOOSE JAW.—The by-law to expend \$35,000 on extension of lighting system, was carried.

STETTLE, ALTA.—This municipality is to install an electric light plant of which, it is stated, the John Galt Engineering Co. have charge.

INGERSOLL.—Mr. Ross, of the firm of Ross and Holgate, Montreal, has been engaged to prepare plans, get tenders, and generally supervise the recently-acquired plant of the Ingersoll Electric Power and Light Co.

WINNIPEG.—A power sub-station will be erected by this city, to cost \$11,400.

OTTAWA.—F. D. Monk, M.P., chairman of the Water Powers Committee of the Commission on Conservation, was here last month conferring

with Hon. Clifford Sifton. The committee is making a complete inventory of all the water powers of the Dominion and they will be classified into public and private powers, developed and undeveloped. A grant for the purpose was made at the last session of Parliament, and it is expected that the information will be very valuable, not only to the Conservation Commission, but also as affording correct statement of the total potentiality of such resources.

PORT HOPE.—J. A. Culverwell, of this city, managing director of the Central Ontario Power Co., owners of Bureleigh Falls and Buckhorn Falls, located just north of Peterboro, states that these properties are not for sale, and that his company has not joined the power merger.

COBALT.—The Mines Power Co. have taken a lease of Waitait Falls on the Mattagami river, near the Porcupine gold camp. This power is said to be one of the best in the north country.

GALT.—The contracts for the Hydro-Electric distributing station have been let to the Packard Electric Co. and the Canadian General Electric Co. for \$9,194.

INGERSOLL.—W. R. Reynolds, of St. Marys, who has been manager of the electric plant and waterworks of that town for over three years has been appointed manager of the Ingersoll electric light plant.

TORONTO.—The officers of the Toronto Electric Light Company announce that they are about to open an aggressive campaign looking towards the further doing away with the poles on the city streets. The work of making the change will commence at once in the business districts and will spread through the city as fast as the company can arrange for the work.

BROCKVILLE.—The Brockville Light and Power Department will erect a new power house adjoining the waterworks pumping station for the purpose of combining the plants.

New Companies.

The Universal Gas Co., Toronto; capital \$5,000,000; to carry on business as mechanical engineers, gas engineers and manufacturers of machinery, to manufacture and supply gas for power, light and heat. Incorporators, G. A. Bronder, New York, W. H. Pearson, A. J. Jackson, Toronto.

The Montreal Shirt and Overall Co., Montreal; capital, \$150,000; to manufacture men's boys' and ladies' garments. Incorporators, S. W. Jacobs, A. R. Hall, I. Ballon, Montreal.

The National Button Co., Montreal; capital, \$99,000; to manufacture and deal in all kinds of buttons. Incorporators, F. E. Gilman, A. W. Powell, T. C. Haynes, Montreal.

Algoma Iron Works, Sault Ste. Marie; capital, \$500,000; to manufacture and deal in iron, nickel, steel or any other ore products of the mine also to manufacture coke and charcoal. Incorporators, J. F. Taylor, T. Gibson, H. P. Barnett, Toronto.

The Universal Metals and Aluminum Solder Co., Quebec; capital, \$100,000; to manufacture and deal in solder for all metals including aluminum, and also to manufacture all kinds of metals. Incorporators, H. Dussault, J. E. Dussault, Levis, Que., and O. Turgeon, Quebec.

The Dominion Stamping Co., Walkerville; capital, \$100,000; to manufacture and deal in stamped goods of all kinds, automobile parts, stove parts and sheet metal work. Incorporators G. S. French, F. J. Armstrong, P. B. Lugster, Detroit.

The George H. King Co., Woodstock; capital, \$25,000; to purchase the business and factory owned by George H. King, to manufacture and deal in all kinds of vacuum carpet cleaners and sweepers. Incorporators, G. H. King, R. C. Campbell, J. C. Campbell, Woodstock.

The Mechanical Equipment Co., Montreal; capital, \$50,000; to carry on the business of iron founders, mechanical engineers and manufacturers of all kinds of machinery, tool makers, press founders, metal workers, boiler makers and ma-

chinery. Incorporators, S. Davis, J. Presner and J. Franklin, Montreal.

Canada Machinery Corporation, Toronto; capital, \$3,000,000; to carry on the business of manufacturers of iron and machinery iron founders, tool makers, brass founders and metal workers. Incorporators, H. Riley, E. G. McMillan and W. H. Walter, Toronto.

Planing Mill News.

WINNIPEG.—The tender of T. D. Robinson & Sons for the supply of 1,000,000 feet, B.M. lumber, at \$25,143.75, was accepted by the city council.

SPANISH RIVER, ONT.—The saw mill of Wm. Milne & Sons, was destroyed by fire. Estimated loss, \$40,000.

DURHAM, QUE.—One of the largest timber deals in the eastern townships of Quebec has been effected by the Brompton Pulp and Paper Co. acquiring the limits and sawmills of the Champoux Company, doing business in the Quebec Central district. The limits cover an area of 18,000 acres and \$200,000 has been paid down.

OWEN SOUND.—J. S. Findlay has advertised his planing mill for sale.

BENTINCK, ONT.—Edward Cawley, sawmill owner, has assigned to Henry Hunt.

Railway Development.

OTTAWA.—Construction on the new railway from Ottawa to Brockville will be begun this fall.

TORONTO.—A charter has been granted to a company, represented by J. B. Bartram, Toronto; Thos. B. Fogg, Toledo, Ohio, railway manager; G. H. Raw, and S. Hirsch, London, Eng. They will proceed shortly from Dixmouth to Guysboro and from New Glasgow to Country Harbor.

WINNIPEG.—The C.N.R. have let the contract for the construction of sixty miles of railway, between New Westminster and Chilliwack, B.C., to the Northern Construction Co., of this city.

VANCOUVER.—The contract for the construction of the first section of the Kettle River Valley Railway, the road which will link Vancouver with the Kootenays, was awarded to the engineering firm of Macdonald, Gzowski & Co., of this city.

PHOENIX.—The Canadian Pacific Railway between here and Eholt, B.C., is now the scene of great activity, the grading and laying of new track having been commenced in earnest. Over one hundred men are employed. The entire ten miles of track is being raised from eight to ten inches, the material for grading and ballasting being brought from a gravel pit, one mile west of Eholt on the Greenwood road. The old steel is being replaced by new 80-pound rails and the new work is expected to cost upwards of \$20,000.

HALIFAX.—A contract between the Nova Scotia Government and the Halifax and Eastern Railway Co. was signed recently for the building of 204 miles of railroad from Halifax to Guysboro, with a branch across the province from New Glasgow to Country Harbor, on the Atlantic seaboard. The enterprise has been promoted by J. B. Bartram, of Toronto, and the company is composed chiefly of London capitalists. The road will be completed within three years. It has subsidies from the provincial and Dominion governments of \$12,800 a mile.

EDMONTON.—The contract for the construction of the main line of the Canadian Northern Railway from here to the Yellowhead Pass has been awarded to McMillan Bros.

DUNCAN, B. C.—A branch from here to Cowichan lake will be erected by the E. & N. Railroad, to connect the \$750,000 lumber mill, which is to be erected on tidewater.

OTTAWA.—The Dominion government has decided to go ahead with the construction of the Hudson Bay railway. At the recent session an appropriation of \$300,000 for construction purposes went through, and since then the plans and specifications have been in preparation for the section of the line on which surveys were completed. Tenders are to be called for at once.

HAMILTON.—The Toronto, Niagara and Western Ry. Co. have filed with the Hamilton city clerk a revised plan of a proposed route between Burlington and Hamilton. The new plan shows the road being built on the north shore of the bay, close to the water's edge. Instead of following the shore line at the end of the bay, the Government proposes to make a short cut by building a bridge half a mile long and tunnelling under the G.T.R. tracks.

BERNE, SWITZERLAND.—The International Railway Congress, after adopting the conclusion of the several sections as reported in the federal body, adjourned on July 16, to reassemble at Berlin in 1915.

Structural Steel.

QUEBEC.—The Phoenix Bridge Co. have appealed to the Court of King's Bench, here, from the verdict recently rendered by a jury by which they were condemned to pay a victim of the Quebec bridge accident named Haley \$20,000.

TORONTO.—The Canada Foundry Co. have been awarded the contract for the superstructure of the bridge over the Saskatchewan River, for the Canadian Northern Railway.

STRATHCONA, ALTA.—A by-law to provide for the raising of \$38,000 for construction of bridge over Mill Creek ravine was submitted to the ratepayers on July 20.

HAMILTON.—Shareholders of the Hamilton Steel and Iron Co. at the annual meeting on July 6, almost unanimously ratified the terms of sale to the Canadian Steel Corporation. A. B. Mackay was the only dissenter, and he refrained from voting because he said he wanted more information. The old board was re-elected as follows, to serve until the merger takes over the company: C. H. Wilcox, president; Robert Hobson, vice-president and general manager; Geo. S. Lynch-Staunton, William Southam, C. E. Doolittle, E. B. Osler, W. D. Matthews, John Milne and H. H. Champ, directors.

TORONTO.—The contract for the superstructure of the bridge over the Saskatchewan river at La Pas, in connection with the Hudson Bay Railway has been awarded to the Canada Foundry Co. of this city.

EDMONTON.—The tenders for the west end bridge were as follows: The Algoma Steel Co., f.o.b., Edmonton, \$22,800. The company promise shipment of steel in three or four months. The Dickson Bridge Works Co., \$29,960. Walker and Barnes' tender in behalf of the Canadian Bridge Co., was: Steel delivered at site, \$24,588, erected ready for planking and paving, \$30,000. Gorman, Clancey and Grindby tendered for the Dominion Bridge Co., f.o.b. site, \$24,650; erected, \$29,240.

EDMONTON.—Tenders are called for the Canadian Pacific Railway for the high level bridge between here and Strathcona, estimated cost \$2,500,000.

Building Operations.

SOUTH VANCOUVER.—The plans and designs of three new schools for this city submitted by J. H. Bowman, architect, were accepted. The cost of the three new schools totals about \$120,000.

WOODSTOCK.—The ratepayers here will be asked to vote on an \$85,000 city hall by-law.

FORT WILLIAM.—The Bank of Commerce will build a new office building here to cost \$60,000.

MONTREAL.—The old post-office on St. James St., will be re-modelled to the extent of \$80,000.

VANCOUVER.—C. T. Perry has prepared plans for St. James Church. Estimated cost, \$100,000.

VICTORIA.—A \$125,000 addition will be made to the Empress Hotel here.

WATROUS, SASK.—Adam Reid, of this place, was awarded the contract for the erection of the Manitou Lake Sanatorium, at \$50,000.

EDMONTON.—The contract for the new hospital building here has been awarded to the Connell-Spencer Construction Co., at \$170,000.

EDMONTON.—It is stated that J. H. Rudy is preparing plans for a new theatre which will cost about \$70,000.

TORONTO.—An addition will be made to the Victoria University, here. The new building will be known as the Burwash residence, and will cost \$230,000.

WINNIPEG.—J. Johnson will build \$40,000 apartment house here.

MONTREAL.—A new building will be erected by the Notre Dame hospital authorities here.

NEW WESTMINSTER.—A horse show building will be erected for the Provincial exhibition at this place.

VANCOUVER.—H. O. Lee will build a large business block here, to cost \$100,000.

WINNIPEG.—The board of directors of the Children's Hospital, here have purchased the old Ladies' College site on which they will erect shortly a new hospital. Cost of site and proposed building, about \$80,000.

MONTREAL.—Jos. Venne, architect, is preparing plans for an extensive amphitheatre to be erected on Mount Royal, in the interests of the Eucharist Congress, to be held in this city in September next.

WINNIPEG.—Leonard Kenwick, Winnipeg, is the architect for the new St. John's Anglican Cathedral. The nave will be erected first at a cost of \$75,000.

MONTREAL.—Peter Lyall & Sons have been awarded the contract to erect on the Seminary of St. Sulpice property, here, a ten-storey office building to be, it is said, the largest in Canada and to cost \$1,000,000.

VANCOUVER.—Kelly, Douglas & Co., wholesale grocers, of Vancouver, New Westminster and Prince Rupert, will immediately commence the construction of a large new warehouse at the Grand Trunk Pacific terminal, Vancouver.

TORONTO.—The contracts for the central wing of the Toronto Western Hospital have been awarded by the Board of Governors. The Hamilton Bridge Co. will supply the steel work; Douglass Bros., the galvanized iron work, and A. M. Brown, the painting and glazing. The steam heating and plumbing has not yet been let. Cost of wing, \$50,000.

General Manufacturing Notes.

CHATHAM.—Negotiations are in progress for a merger of the four leading natural gas companies now operating in this district, these being

the Volcanic Oil & Gas Co., Leamington Oil & Gas Co., United Fuel Supply Co., and Northern Pipe Line Co. English capital is promoting the merger, which, if completed, will be followed by a big development of the resources of the gas fields, and extensions to London, St. Thomas, and probably other centres of population till now untouched.

CHATHAM.—Arrangements are under way whereby the Dominion Sugar Co., of Wallaceburg, will erect at that place a plant for the manufacture of denatured alcohol as a by-product of the sugar beet. The new factory, it is stated, will duplicate the present sugar factory and employ as many hands.

CHATHAM.—The Empire Oil Refinery, at Wallaceburg, is adding two new stills to its equipment. A plant for the manufacture of wax goods of all kinds is also being erected and equipped.

KINGSTON.—N. C. Polson & Co. will build an extension to their building here.

CALEDONIA.—The Alabastine Co. are erecting a \$50,000 plaster plant at the Caledonia gypsum mines.

TORONTO.—The Pure Gold Mfg. Co. are erecting a warehouse here, to cost \$20,000.

VANCOUVER.—T. C. Prior & Co. will build a \$22,000 warehouse here.

WINNIPEG.—The Sawyer-Massey Co., are erecting a new warehouse.

CALGARY.—Mr. Watson, ex-alderman of Calgary, states that in a few months work on a steel plant and rolling mill will be started here.

TORONTO.—The Massey-Harris Co., will build an addition to cost \$7,500.

OTTAWA.—The Beaver Co., of Buffalo, will build a Canadian branch factory here.

TORONTO.—J. L. Nichols Co. will erect a \$20,000 factory here.

LACHINE, QUE.—The Canadian Railway Signal Co. are erecting \$100,000 plant at this place.

STRATHROY.—The Strathroy Furniture Co., and Strathroy Canning Factory will both enlarge and make additions to their plants here.

MOOSE JAW.—The Gordon, Ironsides & Fares Co., meat packers, will locate their western plant here. They will commence work on the construction of their buildings in the near future.

GUELPH.—R. Gracser, a manufacturing chemist, who has large chemical works in the North of Wales, will establish a chemical works at Guelph.

Canadian National Exhibition

TORONTO

AUGUST 27th to SEPTEMBER 12th, 1910

Improved Grounds, New Buildings, International Live Stock Show,
Exhibits by all the Provinces, Magnificent Art Loan Exhibit.

BY PERMISSION OF HIS MAJESTY

BAND OF THE GRENADEER GUARDS

KING GEORGE'S HOUSEHOLD BAND

400
MUSICIANS

Model Military Camp.
Tattoo every night.
Everything new in attractions.

1,000
PERFORMERS

Wonderful Firework Spectacles.

THE NAVAL REVIEW AT SPITHEAD

BATTLE BETWEEN DREADNOUGHT AND AIRSHIP

WATCH FOR REDUCED RATES AND EXCURSIONS.

For all information write Manager, J. O. ORR, City Hall, Toronto.

JOHN J. GARTSHORE

83 Front St. W., Toronto

RAILS and SUPPLIES

New and Second-hand

For RAILWAYS, TRAMWAYS, Etc.
Old Material Bought and Sold.**OPAL GLASS TILING**

FOR WALLS OF

MACHINERY AND POWER HOUSES

Most approved material.

TORONTO PLATE GLASS IMPORTING CO'Y

PLATE AND WINDOW GLASS

135 to 143 Victoria St., - Toronto

**Oil Tempered
Steel
Springs**—for every purpose
and the best for each
use.—Special styles of
all kinds to order.**THE CLEVELAND
WIRE SPRING CO.**

Cleveland, Ohio.

STEELCRETE**EXPANDED METAL****REINFORCEMENT for CONCRETE FLOORS
and ROOFS.**The most reliable bond for all varieties
of concrete slab.

WRITE FOR HAND BOOK AND SAMPLES

Competent Engineering staff in charge
of construction.**Expanded Metal & Fireproofing Co., Limited**
100 King Street West. TORONTO

MAPLE LEAF
STITCHED COTTON DUCK
BELTING
DOMINION BELTING CO. LTD.
HAMILTON CANADA

draining the northern part of Algoma district into James Bay. From Moose Factory, which stands at the point of the Moose River's discharge into James Bay, the ore deposits are about 60 miles south. They are about 100 miles north of the National Transcontinental Railway and west of Cochrane on the Temiskaming & Northern Ontario Railway, which will eventually be extended to James Bay.

The iron ore deposits at Grand Rapids were not previously unknown. They were discovered in 1875 by Dr. Robert Bell of the Canadian Geological Survey, and were again brought to notice in 1903 as a consequence of explorations made by a party sent out by the Ontario Bureau of Mines. The bureau's report for 1904 contains a description of the deposits, whose contents are classed as of the limonite variety of ore. The ore body is very large, and the metallic iron found in some cases is as much as 60 per cent., phosphorus being present to the extent of about 0.08 per cent. Parties who have been up in the field staking claims this spring bring back very optimistic accounts of the quantity of ore in sight and the quality of it, and they incline to the opinion that the ore is brown hematite. They say that no other known ore body in Canada is to be compared with this one in economic importance. If the ore is as good and plentiful as official and private reports agree in representing it to be, the railway is almost certain to be pushed on to the place at which it is located.

Five New Mallet Engines.

The big Mallet compound engine recently constructed at the Angus shops, to aid in getting freight trains over the grades of the C.P.R. in the Far West, is reported to be doing fine work and it is stated that orders have been given to construct five similar engines at the Angus shops also for work in the West.

Will Establish Steel Works.

Mr. W. Owen, C.E., who contested Merthyr Tydvil, a Welsh borough, against Mr. J. Keir Hardie, the Labor leader, at the general election of 1900 in Great Britain, was in Vancouver recently representing a group of British capitalists who intend establishing large steel works in British Columbia for the manufacture of steel rails, angle bars, wire goods and tin plate.

Mr. Owen was sent out here to make the preliminary arrangements for the establishment of the factories mentioned. It is intended to spend no less than \$15,000,000 in the acquisition of sites, coal and ore supplies, erection of mills and installation of plant, which will be the most scientific and up to date in the world.

While here, Mr. Owen acquired 150 acres of land for a site and also concluded arrangements for the acquisition of the necessary coal and iron ore supply.

Record Car Building.

That the present year will make a new record in car building in Canada is the statement of Secretary Skelton, of the Canadian Car Works merger, who has just returned from a business visit to Amherst, N.S. Mr. Skelton said that orders had been coming in so fast that all the corporation's plants were scheduled for continuous work for some months to come, while there was every indication that more cars would be built in the Dominion this year than ever before.

The railroad prosperity, said Mr. Skelton, had compelled the railroads to give large orders for rolling stock, in addition to the large amount they were building for themselves, and big orders had been received by the company from the Canadian Pacific, G. T. P., Canadian Northern, and Grand Trunk. The majority of this work was for freight cars, mostly of the new type of steel underframe with wooden superstructure. Many of the recent orders have been turned over to the Montreal works, as the shops at Amherst are busy turning out orders for the Canadian Northern.

SPECIAL MACHINERY, Etc.**ARMSTRONG BROS.**

16 Sheppard St., Toronto

Mfrs. of **SPECIAL MACHINERY**

Patents Perfected

GEAR CUTTING, TOOLS, DIES, ETC.

Ruching and Pleating Machinery.

ERNEST SCOTT

91 BLEURY ST., - MONTREAL

Machinist and Tool-maker

Dies for sheet metal work. Stampings and light manufacturing. Special machinery designed and made to order.

The PARMENTER BULLOCH CO., Ltd.
GANANOQUE, ONT.

Iron and Copper Rivets, Iron and Copper Burrs, Curved and Tubular Rivets, Wire Nails, Copper and Steel Boat and Canoe Nails, Escutcheon Pins, Leather Shoe and Overshoe Buckles, Felloe Plates.

OWEN SOUND IRON WORKS, LIMITED**OWEN SOUND, ONT.****Cement Mill Machinery, Boiler and Steel
Tank Work of all kinds, Grey
Iron and Brass Castings****PATTERNS AND MODELS****PATTERNS
IN WOOD**

~ ALL KINDS ~

Difficult Core Work a Specialty
High Grade - Right Prices - Prompt Delivery

SATISFACTORY WORK GUARANTEED

THE HAMILTON PATTERN WORKS258 CATHERINE STREET NORTH
HAMILTON, ONT.**PATTERNS**Patterns and Models All work guaranteed.
of any design. Correspondence Solicited.**JAMES SIBLEY**

Mechanical Draughtsman and Patternmaker.

156 DUKE STREET, TORONTO
one Main, 5747.**Castings****TOUGH, STRONG, GREY
IRON CASTINGS, EASILY
MACHINED.**

Any size up to ten tons

Wm. Hamilton Co., Ltd.

PETERBORO, ONT.

BENCH POWER PRESS

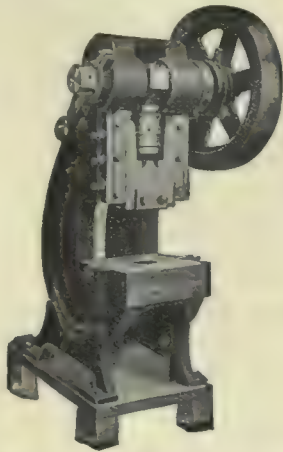

New Design

Particularly adapted for small, quick work, to take place of foot presses.

Write for Prices.

W. H. Banfield & Sons

MACHINISTS, DIE AND TOOL MAKERS
120 Adelaide Street West
TORONTO - - - CANADA

Special Taps Special Dies Special Reamers

Unless you have special appliances, you can get these tools from us better and cheaper than you can make them.

We have the equipment and the experience. Ask us for prices.

A. B. JARDINE & CO.
HESPELER, ONT.

CATALOGUES.

FRICITION CLUTCHES.—Catalogue No. 8, of the Will Clutch Co., Cleveland, Ohio, is a particularly well gotten up 54 page booklet, of very attractive form, devoted to friction clutches. The friction clutches are described and illustrated very fully, the development of the clutch from its original form being shown and the changes noted. A tabulated price list, which shows considerable care in its preparation, is also given. Reference is made to the special flange pulley construction used with the clutch. Quills for use with their clutches are illustrated in detail. At the back of the book a department called Engineering Notes, contains much useful information in power transmission, and every engineer ought to have a copy if for no other purpose than this alone.

PAPER MACHINES.—Escher Wyss & Co., Zurich, Switzerland, have issued catalogue No. 124-P, containing a complete list of the users of their paper machines. In addition, there are several photos of typical installations.

BEATERS AND EDGE-RUNNERS.—Catalogue No. 125-P.B. of the Escher Wyss & Co., Zurich, Switzerland, contains a long list of users of their beaters and edge runners. Short description of the machines are given with illustrations. Some typical installations are also shown.

REACTIONS.—Is the title of the quarterly house-organ of the Goldschmidt Thermit Company, 90 West St., New York. As it states, it is a quarterly periodical devoted to the science of aluminothermics. The second quarterly number, this year, contains 14 very instructive articles, most of which show the application of Thermit-welding to various conditions. Numerous photos of the processes are shown, together with good descriptions, forming very instructive and interesting reading matter.

MACHINE TOOLS.—George Richards & Co., Ltd., Broadheath, near Manchester, Eng., have a very convenient and expansible system for their machine tool catalogue, as it is arranged in loose-leaf form, each sheet descriptive of a different form of machine-tool. A large variety of tools are illustrated, and briefly described. Among the many are:—Side planers, turbine planers, radial drills, slot drills, key seaters, horizontal boring machines, boring and turning mills, combined turret head boring and turning machines, high speed universal facing, boring, drilling and milling machines, vertical millers, grinder for piston rods, etc., and band saws, as well as other minor machines. Quite a variety of each of these types are illustrated and the salient features described in brief form. Every machine shop man ought to have a copy.

GANG SAWS.—Two large leaf bulletins of Wickes Brothers, Saginaw, Michigan, illustrate their gangs Nos. 10 and 12, and their self-contained gangs Nos. 15-19 inclusive. Little reading matter is appended, for the cuts of the machines are made page size and are of particularly good quality, practically self-explanatory. Other publications are also issued by the company.

FANS AND MOTORS.—C. A. Vandersvell & Co., Warple Way, Acton Vale, London, W., Eng., have issued leaflets Nos. F 50-57, F 70-72, F 81-84 descriptive of their C.A.V. fans and motors, in a neat form, fastened in a detachable cover. Most of the information is arranged in tabulated form, and is therefore convenient for reference purposes. It is gotten up in handy desk form.

RECORDING INSTRUMENTS.—Bulletin No. 150, a handsome 64 page book, is the latest of the Bristol publications, and forms an illustrated index of their recording instruments for pressure, temperature and electricity, and their electric pyrometer. As the title page states, it is not a catalogue, but simply a series of illustrations of the most important Bristol instruments

"GLOBE" TIME RECORDERS



are made in Canada by expert mechanics. They are accurate, simple in construction, strong, and of good chaste appearance. They will record with absolute accuracy the arrival and departure of your employees (TO THE MINUTE), making you pay for what you get and no more. All lates and short time marked in red, regular time in green. The small cut at the top illustrates the WEEKLY MODEL, an entirely automatic recorder requiring no attention whatever during the week, as all changes, etc., occur automatically (DONE BY CLOCK WORK). The DAILY MODEL is shown in the cut at the bottom. This recorder is being used mostly in large shops, etc., where a large number of hands are employed. With the "GLOBE" TIME RECORDERS only one operation is required as against five with most others.

Inspection may be made through the glass sides of the case, but tampering with records is impossible, no danger of having soiled, torn or lost records when same are unfavorable, as is the case with all CARD CLOCKS. We are now manufacturing over 224 DIFFERENT TIME RECORDING CLOCKS, and are in a position to meet the requirements of any business. Write us about your needs and let us suggest what will best meet with your requirements. WE SOLICIT YOUR ENQUIRY.

W. A. WOOD, Manufacturer

Head Office and Factory: 40 St. George St., Montreal

Branch Offices:

19 Bleury St., Montreal 65-67 Victoria St., Toronto

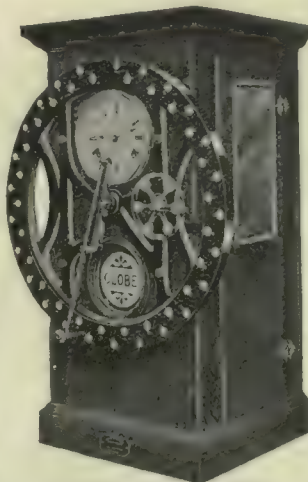

with partial explanations of the instruments and their application. It collects these types in concise form, and more detailed information can be obtained from their individual bulletins, of which they have many. An interesting feature of this bulletin is the history of the company, giving the development of the recording meter from its early stages, up to the present advanced state.

LIFTING MAGNETS.—The Cutler-Hammer Clutch Co., Milwaukee, Wisconsin, have a little eight page folder on their lifting magnets. It briefly describes their uses and possibilities, and gives a cross-sectional view, numbering and describing 18 of the parts. The pamphlet is not intended as a catalogue, but merely gives a few of the more salient features dealt with at greater length in their 48 page Lifting Magnet booklet.

WIRE ROPES AND FITTINGS FOR MINING.—W. N. Brunton and Son, Musselburgh, Scotland, who makes a specialty of every kind of wire rope, have issued this 42 page catalogue which is gotten up for pocket reference use. Notes are given on the handling and care of wire rope and on such things as uncoiling, lubrication, capping, galvanised ropes, winding ropes, and haulage on inclines. Reference is made to a special book on splicing which like this book may be had on application. Various convenient tables are given, and also notes on the "lay" of the wires for best results. Various special connections, etc., manufactured by them are also detailed.

ROLLING DRAWER CORE OVENS.—A booklet entitled a Remarkable Battery of Rolling Drawer Core Ovens, has been published by the J. D. Smith Foundry Supply Co., Foundry Engineers, Cleveland, O. It describes a large installation for the Ferro Machine and Foundry Co., Cleveland, O. These ovens are on the third floor of a building specially built for core making, with larger ovens on the second floor, with sand preparation room on ground floor. This idea of having ovens on second and third floors, and firing from first floor, is a new idea in core oven buildings. The plant is well described and fully illustrated.

FRICION HEADSTOCK AND LEVER CONTROL.—This is described in its application to the Gisholt Vertical Boring Mill, in a pamphlet issued by the Gisholt Machine Co., Madison, Wis. The mechanism has several points of particular value for this class of work, and which are explained in the pamphlet.

ROCKWELL REVERBERATORY MELTING AND REFINING FURNACES.—Are explained in Bulletin No. 10, of the W. S. Rockwell Co., 50 Church St., New York. These furnaces use either oil or gas fuel, but may be designed to use coal or coke. It is suitable for melting and refinery drosses, reducing copper and brass wire and miscellaneous scrap to ingot form, melting lead, tin, zinc, etc., in large quantities, and for melting quantities of brass or bronze for castings which are too large for the ordinary crucible furnace and which cannot be economically cast from a cupola. The description goes on to give details of construction.

GEOMETRIC CHASER OR DIE GRINDER.—is the title of a leaflet issued by the Geometric Tool Co., New Haven, Conn., describing this machine. This machine was designed for the uniform grinding of chasers or dies of no matter what form. This they claim is a necessity to insure a good thread on bolt and reasonable life to chaser. It is adapted to other grinding as well, and has a micrometer attachment for accurate work. It is also fitted with a vise.

DUNHAM VACUO-VAPOR HEATING SYSTEM.—A handsome 40 page booklet issued by the Dunham & Co., Continental Life Bldg., Toronto, goes into the construction and advantages of the Dunham System, and is worthy of

MALLEABLE IRON CASTINGS

PRATT & LETCHWORTH CO. BRANTFORD ONTARIO

ALUMINIUM

"The 20th Century Metal"

Lightest and most adaptable of the industrial metals. Fills a hundred purposes where the ordinary metal fail. Saves its cost over and over again by its lightness and easy working qualities

You can now get your Aluminium requirements promptly attended to by our clients, The British Aluminium Co., Limited, of

INGOTS, BARS, SHEETS, RODS, ANGLES, ALLOYS, NOTCHED BARS, CORNICES, WIRE, CHANNELS, ETC.

London, the largest producers in the United Kingdom.

Sole Agents for Canada: Parke & Leith, 205 Yonge Street (Bank of Toronto Building) - - - Toronto.

To-day get Bulletin "D" on the varied uses of ALUMINIUM (Parke & Leith)

JESSOP'S BEST TOOL STEEL

"ARK" High-Speed Steel

THE FAVORITE BRANDS WITH USERS OF GOOD STEEL.
A LARGE ASSORTMENT OF SIZES IN STOCK.
JESSOP'S HIGH-GRADE FILES AND RASPS.

80 Bay, St., Toronto, Ontario
Chas. L. Bailey, Agent.

Reid-Newfoundland Company
St. John's, Newfoundland.

Jas. Robertson Co., Ltd
Montreal, Quebec

Jas. Robertson Co., Ltd.,
St. John, New Brunswick

WM. JESSOP & SONS, Limited, Manufactory, SHEFFIELD, ENGLAND.

Good, Clean Castings

depend largely upon the facing used. At least, you can't get good castings with poor facings

DIXON'S FOUNDRY FACINGS

help to make the kind of castings that require least cleaning and that are free from hard spots, blow holes, etc. WRITE FOR FREE BOOKLET 223-S.

JOSEPH DIXON CRUCIBLE COMPANY
JERSEY CITY, N.J.

THE BEYER WATCHMAN'S PORTABLE CLOCK



IS TAMPER PROOF
and thoroughly reliable

Shall we send
Particulars?

G. C. BREDIN, Sales Agent
252 Dundas St. London, Canada
Record Dials furnished for all machines.

STAMPINGS

No matter how hard a stamping problem you put up to us, the chances are we can satisfy you. Many people use stampings in place of castings and find them more satisfactory and often cheaper. Send blue prints and samples and let us quote you.

The Silent Partner is an interesting little magazine. We send it free—when there's a reason

THE GLOBE MACHINE & STAMPING CO.
899 Hamilton Street, Cleveland, O.

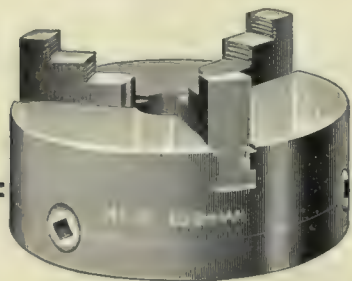

"CUSHMAN" CHUCKS

For general machinists' use.
Strong and durable and
designed for hard service.

Our catalogue shows many
styles and sizes and is sent
free.

The Cushman Chuck Co.

Hartford, Conn., U.S.A.

Established 1862

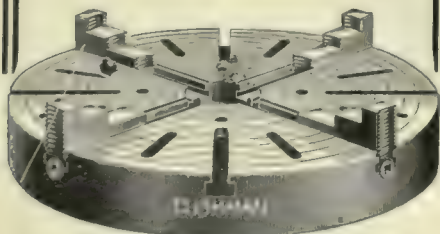

careful reading. Special reference is made to the patent Dunham Trap which is said to act quickly, have large capacity and to absolutely not pass steam. Tests are shown as well as a number of installations with letters of recommendation.

INDUSTRIAL RAILWAY.—An 80 page booklet issued by C. W. Hunt Co., West New Brighton, New York, gives a description of the Hunt Industrial Railway system with illustrations of the mechanical principles and interesting details. Numerous illustrations show the application for handling materials and saving labor.

DRIVING CHAINS.—Renald Driving Chains and their use is the subject of a 130 page catalogue issued by Hans Renald, Ltd., Manchester, and distributed by their Canadian agents Jones & Glasco, St. Nicholas Building, Montreal. The book is a useful treatise on chain drive, many applications being described and illustrated. Chain sprockets are shown and cutters for making them. How to join chains is made clear and the tools needed are shown. Shops with general chain drive, machine tool chain drive, etc., are shown with cost and production tables. The application to wood working machinery is also illustrated.

ROCKFORD MACHINE TOOLS.—The Rockford Machine Tool Co., Rockford, Ill., have issued a neat folder containing illustrated descriptions of a number of Rockford Machine Tools. These include shapers of various styles, both belt and motor driven and Rockford planers in several sizes. The special features of each machine, are pointed out in the description.

ROLL CRUSHER.—Bulletin 39 of the Jeffrey Mfg. Co., Columbus, Ohio, describes the Jeffrey roll crusher for coal, coke, salt, gypsum, etc.

FOUNDRY EQUIPMENT.—A folder from the Adams Co., Dubuque, Iowa, contains illustrated descriptions on coated paper of Farwell Squeezers Universal Molding Machines, Snap flasks, grinders, milling attachments, gear hobber, etc. The operations on the different machines are clearly described and illustrated, such subjects as "How Spur Gears are cut with a Hob," being treated in the folders.

Shelby Tubing.—"Shelby Hot Finished, Seamless Steel Tubing," is the title of a neat little booklet issued by John Mullen & Sons, Ltd., 321 James St., Montreal, who are the sole Canadian distributors of this product. This brochure describes the advent of this kind of tubing on the market, as well as giving a long list of its possible uses.

Foundry Machinery and Equipment.—Is a little 24-page booklet, No. 93, issued by the Northern Engineering Works, Detroit, Mich. To quote the booklet, it "is merely a reminder of what we make in the line of Foundry Machinery." Other catalogues are published by the firm dealing with their products more completely, which are obtainable on request.

The Coventry Noiseless Chains and Wheels.—Is the title of a very instructive 24-page catalogue, issued by the Coventry Chain Co., Ltd., Coventry, England. The development of this chain from its introduction in 1896, is dealt with, as well as a complete description of its present form and applicability to various conditions. Some hints are given for users, as well as an article on the lubrication and care. A number of common uses are cited, and convenient table arranged giving details of various sizes of chain. Mention is also given to the company's Shock Absorbing Wheel, which is worthy of considerable notice.

Jeffrey Conveying Machinery.—In a neat little 24-page brochure, which is catalogue No. 38, of the Jeffrey Mfg. Co., Columbus, Ohio, a general outline of their line of machinery and its wide range of application, is given. The catalogue consists essentially of a series of illustrations, admirably filling the intention of the firm, as it very completely shows their lines of activity. A complete list of their catalogues is given.

The Heating System.—This 12-page brochure describes the Webster Q. R. Modula-

A Constant-Speed Drive

A fundamental underlying principle of a constant-speed drive and the mechanically obtained speed changes incident thereto is convenience.

Any machine so designed as to entail the absolute stoppage of the driving pulley, as well as the machine in order to change speeds by the shifting of a tumbler gear or engagement of a positive clutch does not in any way meet the requirements of the case.

Friction back gears are, comparatively, an advantage, but the quick change so obtained is too great. Quick speed changes should have but a slight increment from one to another, in order that the surface speed of the work may be readily and properly accommodated to the capacity of the cutting tool.

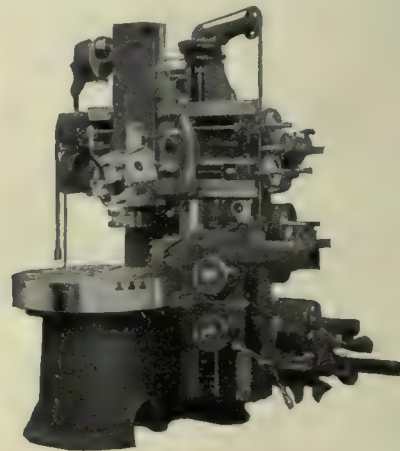

A perfect constant-speed drive is one of the many features incorporated in the VERTICAL TURRET LATHE which tend to make it such a remarkable machine for rapid production of absolutely perfect work.

This feature is only one of the many incorporated in the VERTICAL TURRET LATHE which is fully illustrated in catalog C-15, which is free for the asking.

The Bullard Machine Tool Co.
Bridgeport, Conn., U.S.A.

tion System of Factory and Office Heating, as installed by Darling Brothers, Limited, Montreal. As well as describing the system, and outlining its advantages, an actual test of its efficiency is given. Several important installations are shown, and a number of letters of recommendation given.

ROPE BLOCKS AND SHEAVES.—Anvil Brand Wire Rope Blocks and Sheaves, is a little folder issued by Mussels, Limited, Montreal. Quite a number of different types are illustrated and price lists given.

NEWTON CUPOLA.—This is catalogue No. 51 issued by the Northern Engineering Works, Detroit, Mich., containing 16 pages, describing their type of cupola, laying special stress on its advantages which they claim are rapid, continuous melting, high fuel economy, saving in wear on lining, latest design, best construction, and wide range of work. It is well written and instructive catalogue for foundrymen. The catalogue is illustrated with several line drawings and half-tones.

THOR AIR TOOLS.—This is a four page pamphlet issued by the Independent Pneumatic Tool Co., 1307 Michigan Ave., Chicago, showing the various kinds of pneumatic tools made by this firm. While not descriptive, complete data concerning each of the different kinds is given, as well as size and price. Applications of their use are also shown, giving an idea of the many uses to which air tools can be put.

NEWTON BOLT THREADING MACHINES.—A new form of die head is described in this 15 page booklet, which is catalogue No. 46 of the Newton Machine Tool Works, Philadelphia, Pa. The die head consists of four chaser blocks, each with four chasers, so that machine can be rapidly set to cut any one of four sizes of thread. Other sizes have different chaser blocks. The head is well illustrated. Four pages are devoted to illustrations of other machine tools that they manufacture.

JEFFREY SPIRAL CONVEYORS.—Booklet No. 36, published by the Jeffrey Mfg. Co., Columbus, Ohio, deals with the different types of spiral conveyors made by that firm, illustrating the same and describing their varied uses. Conveyor fittings are also included and complete price list given. The company also manufacture complete coal mine equipment and labor saving machinery for handling bulk and package material of all kinds, a complete list of catalogues for which is given in this booklet.

INSPECTING AND TESTING ENGINEERS AND CHEMISTS.—The Canadian Inspection Co., Montreal, have issued an 8 page brochure with this title. It gives a very complete list of the materials they test, and the quantities for which the tests are made. Special tests are also made by them.

INLAND GALVANIZED SHEET.—A most interesting 32 page booklet is that gotten out by the Inland Steel Co., Chicago, Ill., called The Story of an Inland Galvanized Sheet. This book first describes the circumstances that forced the firm to build their own steel mill to supply the necessary steel for the galvanized sheet that they manufactured. It then goes on to describe the process of manufacture, from the time the ore leaves the Lake Superior iron ore beds till the finished galvanized product is turned out passing through the basic open hearth process, clearly describing the various steps through which it goes, mentioning particularly what they consider are the points of superiority in their own method of manufacture. The book is very instructive, as all the various stages are dealt with so completely. It is very fully illustrated, every step being shown.

STANDARD ELECTRIC TIME SYSTEMS.—Catalogue No. 32, published by the Standard Electric Time Co., Waterbury, Conn., describes their time systems. The system consists essentially of a master clock, electrically self-winding secondary clocks, time registers, etc., and other time-keeping apparatus, for use in any large institution. This

catalogue fully describes the system in all its details. It is a book every manager ought to have when changing his shop system in any way.

OIL BURNING EQUIPMENT.—Circular No. 129, of the late Jones & Co., Inc., Pittsburgh, Pa., describes their fuel oil burning equipment for open hearth furnaces. It is an 8 page circular, large size sheet, and contains a number of illustrations of installations, as well as a couple of plans and sections of plants. Beginning with a general dissertation on the advantages of oil as a fuel for such purposes, presenting several very taking arguments in its favor, it goes on to describe the various parts of the equipment, such as the burners, reversing valve stand, ladle drying and heating burner, and the pumping, heating and regulating system. All these various details are well described and fully illustrated.

TWIST DRILLS, REAMERS AND TAPS.—The 1910 catalogue of the Morse Twist Drill and Machine Company, New Bedford, Mass., is quite a comprehensive book 5" x 7" on coated paper, containing 336 pages, describing and listing their various products, as well as a 28 page appendix, containing many useful standardized tables, and much useful data. It is a book that ought to be in the hands of every machine shop superintendent and foreman. Besides describing their usual stock of increase and constant angle twist drills, reamers, chucks, milling cutters, taps, dies, machinery, and machinists' tools, some 39 new productions are listed. These show considerable developments, with many labor-saving ideas. So many different tools are shown that even a partial list is impossible. The book serves as an excellent reference, containing so much useful information.

RECORDING THERMOMETERS.—The Bristol Company, Waterbury, Conn., have issued Bulletin No. 125, a 12 page pamphlet, descriptive of their class 1 self-contained recording thermometers, which are adapted for low and atmospheric ranges of temperature up to 150 degrees Fahrenheit. The different sizes manufactured by them are shown and described, as well as the accompanying paraphernalia. A brief description is given of the electric alarm attachment, for apprising the operator of too high or too low temperature for the desired conditions.

GRITS AND GRINDS.—The April issue of this monthly news bulletin issued to the sales force of the Norton Company, Worcester, Mass., contains several good articles relative to grinding. The first article details the similarity of operation between grinding wheel and abrasive stones, as compared to the milling cutter, showing that in principle they are the same. The article goes on further to show how the microscope and camera are useful adjuncts in leading to better grinding, illustrating the point with several photos taken under the microscope. These are of interest. Another article on the cause of checking in fine finishing machine tools, is instructive, and consists of several letters, containing the opinions of several men of authority on these lines. Other equally interesting but shorter articles are given as well as some short news items. It is a progressive little house-organ.

FIRE BRICK.—Catalogue No. 2, of the Detroit Foundry Supply Company is entitled Fire Brick and Refractory Material Catalogue. It is a 24 page booklet, descriptive of the various brands of fire-bricks marketed by this firm. It starts in by a general description of fire-brick, going from that to details of the brands, with sketches of all the different kinds. In addition to this, the last few pages contain tables and data of value to foundry men in general, the information being contained in concise and useful form.

PULVERIZERS AND CRUSHERS.—The Jeffrey Manufacturing Company, Columbus, O., have issued a 38 page catalogue No. 31-C describing the

ONE MAN can cut threads on 6-in. pipe with a "BEAVER" ADJUSTABLE DIE STOCK



No. 6, threading 1-4, 3-8, 1-2, 3-4 in. complete.
No changing of Dies or Bushings.



No. 25B, 1 in. to 2 in., R.H. complete.

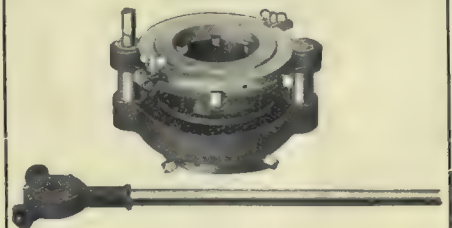

No. 60, cuts 2½, 3, 3½, 4, 4½, 5, and 6 inch pipe.

NOTE—That with the three tools shown above you can thread from 1-4 in. to 6 in. pipe. No loose parts.

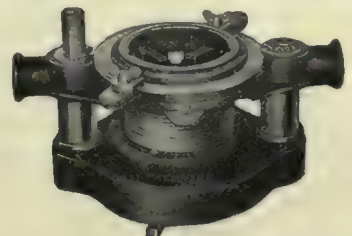

No. 41, cuts 2½, 3, 3½ and 4 in. pipe.



"WARREN" DIE STOCK
(Non-recutting dies adjustable.)
Each stock cuts two sizes. Made in four sizes
Prices \$5.00, \$5.50, \$6.00 and \$7.00.

THEY SAVE TIME AND MONEY
Write for our Illustrated List

Borden-Canadian Co.
Richmond St. East, Toronto, Ont.

Jeffrey pulverizers and crushers. The latest model of Jeffrey swing hammer pulverizer is well described and illustrated, and, judging from the list of firms operating these machines, its usefulness is unlimited, being used in all kinds of pulverizing from bark and chips to hard dolomite rock. Their crushers are also described, special significance being given to the coal, coke and salt types. The rotary crusher and the Jeffrey disintegrator are also given and in addition a complete list of catalogues published by the firm is listed, which is convenient for reference in case of different kinds of machines are required.

ELECTRIC FANS.—The Westinghouse Electric & Mfg. Co., Pittsburgh, Pa. Circular No. 1165. Shows the company's very complete line of electric fan motors for the season of 1910. These motors are designed to operate on the regular lighting circuits at the frequencies and voltages which are in general use.

ROLL CRUSHERS.—The Jeffrey Mfg. Co., Columbus, Ohio. Bulletin No. 39; size 6 x 9 in.; pages 16. Covers the Jeffrey line of crushers for coal, coke and salt. The description of these crushers is supplemented by illustrations of the different parts and tables of dimensions. Space is also given to two types of pulverizers.

FINISHING STEAM TURBINE DISKS.—Gisholt Machine Co., Madison, Wis. Loose leaf circular. Illustrates and describes the finishing of steam turbine disks on a Gisholt 42-in. vertical boring mill. The entire operation from facing the rough forging to completely finishing the disk was performed in this machine, and it is stated that the work was completed in greatly reduced time and had a very fine finish.

VERTICAL TURRET LATHE.—The Bullard Machine Tool Co., Broad Street and Railroad Avenue, Bridgeport, Conn. Pamphlet entitled "The Vertical Turret Lathe for Machining Automobile and Gas Engine Parts." Refers to its use for machining such parts as flywheels, brake drums, sprockets, etc. A number of illustrations show the different operations performed on this machine.

BORING MILLS.—The 40-page, 8 x 10-inch catalogue issued by the Gisholt Machine Co., Madison, Wis., is an excellent piece of work. The line of boring mills, ranging from 30 inches

to 84 inches in capacity, is fully described, views of details being added wherever necessary to bring out prominent features.

FAN MOTORS.—The Westinghouse Electric & Mfg. Co., Pittsburgh, Pa., has issued a 55-page, 7 x 10-inch catalogue descriptive of a complete line of fan motors, of desk, ceiling and fan types, and in a wide variety of designs.

LIFTING JACKS.—Is the title of an attractive 100-page catalogue just issued by the Joyce-Cridland Co., of Dayton, Ohio. Besides listing their complete line of jacks for all purposes, the catalogue also contains discussions of the construction and recent improvements in this line of jacks. It also discusses the relative merits of various types of jacks, such as hydraulic, lever, automatic, automatic geared, screw, telescoping, etc., for different classes of service and recommends the most suitable jack for the different lines of work. The catalogue contains complete information concerning the dimensions, weight, price, etc., of the various jacks, and should be on file with anyone who is interested in the purchase of jacks for any purpose. Copies may be had by addressing the Joyce-Cridland Co., Dayton, Ohio.

BOOK REVIEWS.

COPPER HANDBOOK.—The ninth annual edition of the Copper Handbook, edited and published by Horace J. Stevens, Houghton, Michigan, is just received. This work, which has become a standard authority on the subject for the entire globe, has, in its latest edition, 1628 octavo pages, containing considerably more than a million words, and, in addition to the miscellaneous chapters, lists and describes no less than 7,751 copper mines and copper mining companies, in all parts of the world, descriptions ranging from two or three lines in the case of companies that have died recently, to sixteen pages in the case of one of the largest mines—a mine, by the way, that employs some seven thousand men, and has paid dividends of considerably more than a hundred million dollars. The mine descriptions are the same as in the preceding volume, except that upwards of eight hundred new titles have been added, covering descriptions not

contained in any previous edition. The chapter of statistics, containing upwards of forty tables, treating of copper from almost every conceivable standpoint, has been fully revised, and brought as nearly as possible to date.

The miscellaneous chapters of the book, twenty-four in number, treat of the subject of copper from a great variety of viewpoints, including the history, chemistry, mineralogy, metallurgy and uses of the metal, and this section of the book also has chapters devoted to substitutes, alloys, brands and grades, and a copious glossary.

The plan on which the book is sold remains the same as for seven years past, the publisher sending the book by mail, fully prepaid, to any address ordered, without advance payment of any sort, and subject to approval after a week's inspection. The price is \$5.00. That this unusually liberal plan has proven successful is shown by the statement of the publisher that net losses through returned copies and defaulted payments are less than four per cent. Anyone interested in the subject of copper, as producer, consumer or investor in shares, should write to Mr. Stevens for a copy of the Copper Handbook on the unusually liberal terms noted.

"The Thermal Conductivity of Fire-Clay at High Temperatures," by J. K. Clement and W. L. Egy, issued as Bulletin No. 36 of the Engineering Experiment Station, University of Illinois, is a report of the results of experiments on the thermal conductivity of several commercial fire-clays at high temperatures. A detailed description of the instruments and methods of high temperature measurements is included. Copies of Bulletin No. 36 may be obtained gratis on application to W. F. M. Goss, Director of the Engineering Experiment Station, University of Illinois, Urbana, Illinois.

Algoma Railway Extension.

Thos. J. Drummond, President of the Lake Superior Corporation, is authority for the statement that the Algoma Railway will probably be extended 150 miles to connect with the C. P. R. Probable cost, about \$4,000,000.

FOUNDRY FACINGS SUPPLIES
&
EQUIPMENT

J. W. PAXSON CO.

MOLDING SAND
PHILADELPHIA, PA.

Thor

AIR TOOLS ARE SUPREME

MECHANICALLY
AND ECONOMICALLY.

They are easily superior to all others in power, durability, ease of handling, economy of air consumption and general efficiency. THOR TOOLS are simple in construction; they run without vibration, and little attention and repairs are necessary. ADOPTED AS THE STANDARD IN THE PRINCIPAL PLANTS THROUGHOUT THE WORLD.

SENT ON THIRTY DAYS' TRIAL—express charges paid both ways if unsatisfactory. WRITE FOR DESCRIPTIVE MATTER.

Made in 50 different sizes, covering every possible Air Tool requirement.

Exclusive Canadian Agents—H. W. PETRIE, LTD., 131 Front St. W., Toronto
Cor. St. James and Little St. Antoine Sts., Montreal; 422 Abbot St., Vancouver.

INDEPENDENT PNEUMATIC TOOL CO.

CHICAGO NEW YORK PITTSBURG SAN FRANCISCO

TRAVELERS
HOISTS

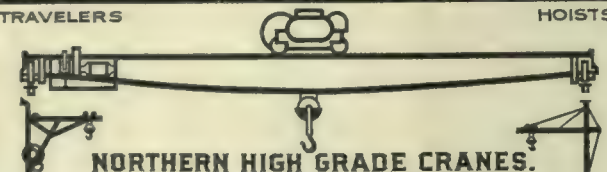

NORTHERN HIGH GRADE CRANES.
NORTHERN ENGINEERING WORKS.

COALING-HOISTS
DETROIT, MICH. U.S.A.
JIB AND PILLAR

THE BEST MELTER AND THE BEST MADE CUPOLA IS THE



NEWTON CUPOLA

LADLES TRUCKS

14 Sizes Free Catalogue

NORTHERN ENGINEERING WORKS, Detroit, Mich., U. S. A.
Canadian Department, ADVANCE MACHINE WORKS, Ltd., Walkerville, Ont.

The advertiser would like to know where you saw his advertisement—tell him.

"The Saving of Heat Units" is a Clue to Larger Profits

How a Leak of \$2,600 was Turned into a Profit—How Manufacturers Can Turn Waste into Profits by Taking Care of Condensation.

By H. L. Peiler *

Modern engineering presents to its students many fascinating features.

Civil engineering has achieved many triumphs of construction, and in its discoveries of the practical application of theory to the utilization of the special qualities of steel and concrete, has overcome so many difficulties, has raised so many and such various monuments to its own skill, that the average man is lost in admiration while contemplating the results.

Electrical engineering, while relatively an infant branch, has made such rapid and brilliant strides that we already regard as ordinary commonplace achievements that less than one generation ago aroused the wonder of the world. It is really difficult to realize how very youthful are such every-day utilities as the incandescent lamp and the telephone. Long distance transmission of currents of relatively high potentials only dates from yesterday.

In mechanical engineering, while progress has been steady, it has not been so rapid, and the advances have come in short rushes with a rest between. In recent years, we have progressed from the single cylinder engine to the compound, from the low-pressure slow-speed engine to the high-piston speed, long-stroke and quick revolution engine necessitating high pressures. Then comes the development of the turbine principle and as a crown to all of these, the successful application of the superheating of the steam. Keeping up with the development of the engine, the steam-generating plant has also progressed, and boilers with their accessories from grates, mechanical stokers, automatic feed-control and other fuel-saving attachments, make the modern boiler-room a very different proposition from that of even fifteen years ago. In another direction, we have the internal combustion engine in its various forms and many other devices for cheapening the cost of power-production and simplifying the complex problems that confront the present day manufacturer when he is contemplating his costs.

In view of all these bright and outstanding achievements in the mechanical world, it seems as if it might be a very difficult task that I have undertaken when I presume to address you on such a commonplace topic as that which has been chosen for me.

I am in the position of the gleaner of

the scriptures. Before me have gone the reapers and the binders, they occupy the whole skyline because their work is more prominent. But in their haste to show large and brilliant results, they have neglected the apparently small waste that lies scattered here and there in the furrows, so small perhaps that it has to be searched for, and yet, in the aggregate, so large that its accumulation hour after hour, day after day, and month after month, presents at the end of a whole year a sum total that is surprising.

Waste of Hot Water.

On going over a certain plant with the owner, I asked him where a particular return line led that originated in



H. L. PEILER.

a dry-room. He replied that it emptied into the drain. I asked how much water he was losing, and he stated that it could not be much and that the water was cheap. However, I managed to arouse his curiosity sufficiently to have the pipe uncovered and the water measured. To his surprise he found that a 50 gallon barrel was filled every 40 minutes and that the temperature of the water near the outlet of this large drier and while still under pressure, was 306 F. His engineer calculated for him the approximate cost, in tons of coal, of heating nearly 250,000 gallons of water from 50 F. to 300 F., and this manufacturer came to the conclusion that he was not sufficiently wealthy to continue that system, when

at relatively low cost, the same water could be returned to the boilers direct and without loss of heat-units. This plant had almost every practical device for making steam cheaply. High-class boilers, modern engines, approved equipment everywhere, including ball-bearing shafting and everything to reduce friction loss to a minimum, and yet this was only one of a series of "leaks" that were discovered during a careful investigation, and eventually he found that leaks, which cost him \$1,800 to stop, had for years previously been trickling \$2,600 annually into the drains. Everybody possible had apparently been done to make the whole plant modern and up-to-date, which is equivalent to saying "economical to operate," but the men in charge had neglected to "look into the furrows." This is only one of a series of similar incidents which I can recall in my own experience.

I am a hunter of leaks, and this saving of the heat-units in the water of condensation, while being on a superficial view only a very minor matter, is one of those smaller details of the engineering field that seems to be fated to be left to some hanger-on of the profession like myself, and it keeps me very busy gleaning what I find in the furrows. If I were permitted an attempt at a joke, even on such an apparently mirthless topic as condensation, I could say that it keeps me constantly "in hot water."

Present Day Conditions.

For purpose of comparison, it is necessary for me to state briefly the conditions that are most frequently met with in steam-using plants in this country. They are of course quite familiar to all engineers. The steam is trapped at the point of discharge at the apparatus in which it is used. The water is then usually run by gravity to some low point; gathered in an open heater, vented receiver or hot well, and after the make-up-water has been added, the boiler is fed from this central reservoir. Where the steam is used under very low pressure (0-5 lbs.) and where exhaust steam from the engines is mixed with this low-pressure live steam, the temperature of this water of condensation upon reaching the receiver is frequently under the boiling point and the addition of the cold make-up water further reduces it to a point where it can readily be handled by a good hot-water

*Of Peiler & MacKenzie, Montreal.

pump. Under these conditions, it is not uneconomical to handle the returns in this manner. But here I would like to point out that in drawing hot water from an open heater or receiver, and passing it through a pump, the temperature is still further reduced, and many engineers who have thermometers on the heater or receiver, overlook the important fact that in most cases they lose from 8 to 12 degrees between the heater and the point where the feed-water enters the boilers, and that this means a direct loss of from 2-3 to over 1 p.c. of the total fuel consumption.

However, there are very few plants that answer to this description. In nearly every industrial process in which steam is used for heating, drying or boiling, it is more economical to use higher pressure in order to obtain the greater rapidity of result from the higher temperature. Even in paper mills and the finishing departments of textile mills it is usual to find pressures of from 5 to 10 lbs. used for drying. In laundries, in breweries, in confectionery boiling, in wool and cotton drying and many other lines of work, 60, 80 and even 100 lbs. pressure are usually employed, and in all these cases the pump and receiver method is wasteful. It must be remembered that in a dry-room, for instance, on which 80 lbs. pressure is carried, the water of condensation as it leaves the outlet, and while still under pressure, has almost the same temperature as the steam from which it originates, that is to say about 320 degrees F. When this water reaches atmospheric pressure, it at once cools by expansion to the boiling point, and throws off 108 degrees of its temperature, and a considerable portion of its own bulk in the form of expansion vapor, all of which is a dead loss. It is manifest to the most inexperienced new hand, that if this water can be carried back direct to the boilers without being allowed to expand, there will be an absolute saving of the amount of coal necessary to re-heat this water by the 108 degrees that it has lost. When one recalls the fact that steam or hot water under even 5 lbs. pressure has a temperature 16 degrees, at 10 lbs. 28 degrees, at 30 lbs. 62 degrees and at 60 lbs. 95 degrees above boiling point at atmospheric pressure, and that between 10 and 12 degrees increase in the temperature of the feed-water means a theoretical saving of 1 p.c. in the fuel account, it follows as a natural consequence that it is wrong in theory as well as in practice to cool off water and then spend good money in replacing a loss of heat that can readily be retained and used over again.

Stormont Mill Installation.

If the water can be returned into the boilers above the evaporation point, at

atmospheric pressure, the gain is very much larger in proportion than if the boiler-feed is below the boiling point. The reason for this is that the working capacity of the boiler has been changed, and has been brought to a state where the boiler is more efficient in heat-units. This difference of efficiency must be also credited to this method of feeding, and the change will naturally show greater total results, than if the saving has been computed from changes due to the difference in the temperature of the feed-water alone. I give one interesting case out of a number I have met in my own experience. In the Stormont mill of the Canadian Colored Cotton Mills Co., at Cornwall, Ont., when the average temperature of the boiler-feed was 165 deg., five 80 h.p. boilers were used to do the drying and dyeing. Under the re-arrangement now in force, about 80 per cent. of the feed-water goes back direct to the boilers through return traps at 280 degrees, the make-up water at 140 degrees making the average temperature of the boiler-feed 252 deg. F. This shows a gain of 87 degrees with a theoretical saving of about 8 to 9 p.c. in fuel. In reality, two of the boilers have been shut down, the other three are more efficiently operated, and the actual saving in fuel is over 30 p.c. allowing for the fact that a portion of the dyeing plant has been removed to another mill. This was originally a receiver and pump lay-out with the make-up water running into the receiver-tank to cool the returns, and nothing was done by me, except to handle the returns independently from the make-up. The cost of making the change actually pays for itself in this plant every six months.

In many sections of Canada, and particularly throughout Central and Western Ontario, another consideration is that of the quality of the feed-water. Every engineer realizes the value of using the condensation over again, and how much it improves his general conditions to minimize the amount of fresh water that is fed into the boilers, and most of which in many places has to be paid for. And yet, for some unknown reason, I find many plants where the engineer appears to have failed to convince his owners. Only last week I was in a factory in Western Ontario, where the feed-water is so bad that the 2-inch feed pipes to the boilers are practically choked up completely every four weeks by the heavy deposit of solids from the water. In this same plant, the exhaust from two engines and four pumps is utilized for heating water for manufacturing purposes, but every drop of this valuable condensation is allowed to run into the sewers.

Enough distilled water is wasted to feed one 125 h.p. boiler practically continuously.

If it were a matter of enormous expense or engineering difficulty to save and use this water, one could understand the objection. But it is such a simple problem, and as this water is always at or near the boiling point, the saving in fuel would also pay for the cost in a reasonable time. All that is necessary is an oil-separation system, and a trap or pump that will lift this water back to the feed system.

While the attention of power users in Ontario and elsewhere at the present time is being largely attracted to electricity, this also opens up an equally large field for the steam-trap, especially the return trap. While we have our good Canadian climate to contend with, and while we need heat for boiling, drying and other purposes, so long will we require steam. Where steam is used for heating only, the return trap will operate efficiently with a much lower boiler-pressure than is required to work a pump. However, it is entirely automatic and its simplicity, lowness of operating and up-keep cost, and other advantages, make the return steam-trap in every way more desirable than a pump for boiler-feed purposes. Where the lift from the lowest point of drainage to the top of the boiler is low (say, 6 to 8 feet), a boiler-pressure of 6 to 10 lbs. is ample.

A very little experience will show that results will be obtained much lower in cost than by any other system of heating. There is no loss of heat-units between the point of drainage and the boiler. This is the important factor of saving.

Another equally important matter, and in fact one that in some cases is more important, is that of the proper trapping of steam-using machinery of every description. It is a point that has been very much neglected by the engineering profession. The steam-trap in general has been condemned by many engineers and is a cause of dissatisfaction in many factories and plants. An examination of the conditions will often show the reason. The chief reason, in my experience, is that steam-traps are seldom purchased intelligently. This may appear to be a strong statement to make, but it is an absolutely true stricture, and one which I am able to substantiate.

Causes of Trouble.

The first great cause for this, is that extremely few engineers take the trouble to find out what the actual quantity is in pounds or gallons of water that is condensed in any given process or machine. The ratio of water condensed from steam varies enormously according to the service performed by

that steam. It is ordinarily calculated that one square foot of radiation used for heating an ordinary building will condense .625 of a pound of water per hour, when the building has been heated to 68 degrees F. But this will vary according to the construction of the building, the amount of glass surface and the humidity of the air as well as its changes in a given time due to wind. Condensation in a dry-room will vary according to the moisture of the goods being dried. A mangle in a laundry will condense more steam or less, accordingly as the quantity of the goods passing over it in a given time is greater or smaller. Indirect coils where air is forced over the pipes, will show enormous differences when the air is drawn from out-of-doors and when the air is re-circulated within the building. A vacuum pan will condense steam much more rapidly than a pan in which the same liquid is boiled at atmospheric pressure. Every process shows different results, and a proper test of the quantities almost invariably shows that the ordinary methods of guess-work run from 25 p.c. to 50 p.c. too low. It is quite usual to find a steam-trap with an interior valve-opening of $\frac{1}{4}$ -inch, and actually able to discharge about 10 lbs. of water per minute with 5 lbs. pressure, placed where it has to take care of double that quantity of water, a thing that it is not possible to do. The trap floods, it refuses to do work that is against all natural laws, and in consequence the trap is blamed, and not the man who attempted to force it to do impossibilities. A certain amount of blame also attaches to the engineer, because the chances are that he probably did not by actual personal investigation, find out for himself the size of the opening through which the water had to pass. On the other hand, a certain amount of blame attaches to the makers of these traps, who fail to inform the engineering public of this most important detail in trap construction.

Ordinary so-called catalogue ratings are useless. They are usually based upon a fixed pressure of, say 50 pounds, and their drainage capacity in feet of one-inch pipe, is misleading. No allowance is made for varying conditions, and a trap that will handle a given quantity of water at 50 lbs. will do nothing like that amount at 5 or 10 lbs. pressure.

Every engineer knows that in order to obtain from steam the heat-units which he wishes to utilize, he must first condense that steam. Engineers know that in order to obtain the best results, the apparatus must be drained quickly, and most engineers know that condensation does not usually leave the apparatus in a steady stream, but that

the water nearly always comes in gulps and sudden gushes. It is this maximum condition that must be taken care of by the trap, and the most economical and useful trap is that which is a little larger than the actual average condition calls for.

With steam traps, as with every other kind of machinery, it is mistaken economy in every way to buy too small sized units. The over-loaded boiler and the over-loaded engine are expected to give poor results in the long run, and yet I think I am not in the least guilty of exaggeration when I make the statement that fully 60 p.c. of all the steam-traps in use in this country are over-loaded and expected to do work of which they are not capable. This means another direct loss in the efficiency of the apparatus being drained, and in many cases reduces the output as much as one-half.

I wish to emphasize this important feature, and it covers the two great points to be aimed at in the economical handling of condensation, namely, that, first, all steam-using machinery should be amply and quickly drained, and secondly, the water of condensation kept under pressure and returned direct to the boilers without loss of its heat-units.

Trap System.

The method of doing this is simple. A proper system of proper traps will do the work automatically. The up-keep expense is practically none, and depreciation allowance less than that of any other part of an ordinary power-plant. Return lines should be covered to retain the heat in the water; this is a practice which I always suggest and which the results justify.

It is usual in most steam-using plants to cover the supply pipe and leave the return pipes uncovered. You will tell me that the reason for covering the supply lines is to prevent excessive condensation in the line through radiation of heat through the pipe. My argument goes farther. Prevent that same radiation loss in the return. It represents just as much cool on the return side as in the supply side. If you can handle your water into your boilers under pressure as hot as you get it, why allow any unnecessary loss at either end? Pipe-covering only represents a small first cost; loss of heat by radiation represents a perpetual expense in coal.

By a proper trap I mean one of ample discharge capacity, and not a trap of the kind that requires a cooling of the water to open its valve, such as the usual expansion type. Remember that your object is to utilize as fully as possible every heat-unit contained in the water as it leaves the place of condensation. The rest is merely an applica-

tion of ordinary common sense and reasoning power. Get your condensation back above the boiling point at atmospheric pressure, and you are making money.

It is difficult to imagine what argument any owner or engineer can set up against the proofs of economy that can be submitted in favor of this method, and yet I find that many owners and engineers of plants where the old methods exist have the greatest prejudice against venturing on a change that is such a simple and reasonable one. I have made these changes in a great number of industrial establishments, and in every case the owners have expressed their regret that the change had not been made sooner.

One question has been frequently put to me, and that is: "If this thing is so simple and if the saving is so large, why has it not long ago become the general practice?" "Why is it not the rule rather than the exception?" My answer to this is that this is a young country, and that technical education was until recently almost an unknown quantity. Our conditions in the early days were peculiar. We had an apparently unlimited amount of fuel at our doors, and we were a wood-burning nation, even our railways burning the wood that was piled up everywhere, a refuse from the clearing of the land. Then we began to manufacture, and every aim was directed at increase of output. Go to many of our largest manufacturing establishments to-day, especially those that have grown with the country during the past thirty or forty years, and I can instance numbers where the original plant can be traced, now a small corner of a large factory. Around it have grown the subsequent additions and extensions, a new building here, another there, not built and located according to one preconceived plan, but simply thrown on anywhere where room or convenience dictated, to meet the temporary exigencies of our growing time. "Output" has been the moving factor.

In the meantime, cheap fuel has gone and coal must be bought. Competition has arisen in nearly every line that compels closer margin of profit. Every effort is made to procure the latest types of machinery, the most modern processes, more skilled labor. But it has only recently come to the point that every other means for cheap production having been exhausted, the manufacturer is forced to turn his attention to other methods of increasing his ever smaller margin of profit.

There is no other line left open. Wages must remain at their present high level, owing to other economic conditions. Other charges are fixed by persons whom the manufacturer cannot

inch diameter, it is only fair to state that a pin $1\frac{1}{8}$ inch in diameter can be reduced to 1-25-32 inch in diameter in $1\frac{1}{2}$ minutes by the ordinary operator. As a matter of fact, it would be to the advantage of the grinding machine if the whole pin were $1\frac{1}{8}$ inch diameter instead of having the $1\frac{1}{2}$ inch diameter depression. The wheel would then perform a uniform amount of work across the entire face and would stand up even better than it now does.

The rough grinding of the pins completes the roughing of the shaft all over and it may now be finished. The pins are first finished and then the bearings. After squaring the ends to the proper length, the shaft is complete.

The method above described applies only to shafts that require no finish on the "cheeks" and that do not have a considerable depth to the thrust shoulders. Regarding this latter feature, our experience up to date leads us to believe that it is not wise to attempt to grind with a full width wheel when the thrust shoulder, beyond the fillet proper, is more than $\frac{1}{8}$ -inch high. Oftentimes a slight increase in the fillet radius will bring the shoulder within this limit.

Besides the rapid removal of stock by using this method, there are two very important time-saving features; the first lies in the fact that the fillets are made by the wheel at one and the same time that the stock is removed from the balance of the shaft. This is possible because the wheel corners are rounded to the proper curvature by means of a simple radial truing device, which is a part of the crankshaft grinding machine.

The second time-saving feature is due to the Norton Grinding Company's patented method of spacing the work table along through a predetermined distance, and there fixing it by means of a spacing bar and locating pin, while the wheel cut is being taken. This method gives extremely accurate lengths and at the same time eliminates all need for measurement on the part of operator. In a crooked piece like a crankshaft the measuring takes as much time as the actual cutting time.

Such a shaft as the one shown should be produced by fairly good men using a plain grinder, and any good 18-inch engine lathe as follows:

Cut off ends and centre.....	6	minutes
Rough grind bearings	15	"
Turn ends	8	"
Rough grind pins	20	"
Finish grind pins	20	"
Finish grind bearings	25	"
Square ends	6	"
Total	100	"

This includes handling, wheel dressing, etc.

Calipering of Car Wheels and Axles for Mounting

The Subject was Discussed at the Recent Convention of Master Car Builders in Atlantic City, and a Number of Good Rules were Suggested.

It is important to remember that good work cannot be performed without good tools. Proper shop practice will not permit lathes and boring mills to get in bad repair. Lathe centres out of line or the V's worn may allow an axle to be turned tapered. A tapered wheel seat with the wheel bored straight cannot be expected to make a proper fit at any mounting pressure.

A very satisfactory test for lathes is to take two or three light cuts from an

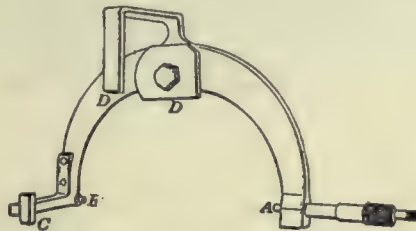

Fig. 1.—Caliper for Wheel Slats.

axle-wheel seat, say seven inches long, and measure the diameters with micrometer calipers. Good practice indicates that there should not be a variation in diameter exceeding 0.002 inch. The same attention given to lathes should be extended also to boring mills to see that they are in proper condition to turn out good work.

The general tendency has been to finish axles with too rough a wheel seat, which results from too coarse a feed. This makes only partial contact between the wheel seat and axle. While axles may hold satisfactory under these conditions, there is always an element of uncertainty, which can be eliminated by better practice. The axle, roughly turned in this way, cannot be accurately calipered, and this is the essential to good fitting and security. Furthermore, in mounting the wheel, the high ridges obtained with a roughly turned wheel seat are pushed off, principally at the outer end of the axle, reducing its diameter and making the turning of the wheel seat necessary when preparing the axle for mounting wheels at a later time. There is, also, a bad moral effect on men who, if permitted to carry out this practice, will extend it to journals as well.

It has been demonstrated that with fairly rigid lathes axles can be turned at a speed of 40 to 50 revolutions per minute, the limit of speed being the chattering of the tool rather than the cutting speed. With this high-speed run with a fine feed, an axle can be turned in about the same time as by slow speeds

and coarse feed. The higher speed results in better work without increased cost.

Having secured straight and true wheel seats and wheel bores, the next necessity is for the proper diameters necessary in secure mounting.

Micrometer calipers are necessary for several reasons. The axles and wheels can be calipered more quickly and more accurately than by machinist's calipers or snap gages. The "draw" or difference in diameter of wheel seat and bore which has been determined for a proper fit, can be secured without difficulty. The difference between diameters of wheel seat and bore of wheel expressed in thousandths of an inch, can be measured accurately, whereas with ordinary calipers it is a question of skill of the workman and with snap gages the same is true to a lesser degree.

To successfully use the ordinary trade micrometer caliper for wheels and axles, takes time and a certain amount of skill. To reduce this time and skill to the minimum, micrometer calipers have been designed and used successfully. Fig. 1 shows a caliper for wheel seats. A is an ordinary micrometer head that can be bought in the open market; B is the anvil; C is a stop set square with a line through A and B; D is a stop or limit which may be turned, so that the distance from the stop to the line from A to B shall be approximately the radius of the wheel seat. In practice, this stop D for the $5\frac{1}{2}$ x 10-inch journal axles is correct for wheel seats $6\frac{1}{2}$ inches in diameter, and is approximately correct

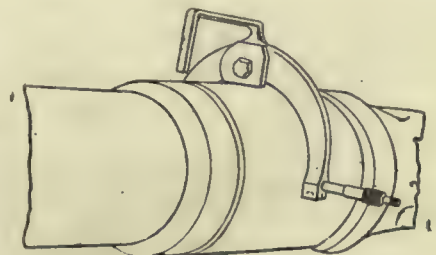

Fig. 2.—Caliper Resting on Wheel Slat.

for wheel seats from $6\frac{1}{2}$ inches to 7 inches. By turning the stop D one-quarter turn, it is suitable for 5 x 9-inch journals.

In using this caliper, it is placed over the axle, with stop D resting on the wheel seat, as shown in Fig. 2. The stop C and anvil B are then brought firm against the wheel seat. The micrometer is screwed up by a ratchet stop until the

ratchet clicks. The caliper is then removed and read. On a trial, eight axles were measured in five minutes, and twelve wheels were measured in the same space of time. Each wheel seat was measured at three points, the average taken and size chalked on the axle. The wheel seats had not been previously measured, and but few were of the same size. This is much more rapid than calipering by other means, especially for axles varying in diameter.

Fig. 3 illustrates a caliper for wheel bore. A is the micrometer head, but graduated for internal measurements; B is the anvil; C the stop set at right angles to a line from A to B; DD are right and left-hand screws, turning together by means of a link not shown in sketch.

In calipering a wheel the screws DD are roughly adjusted somewhat smaller than the bore of the wheel. The anvil B and stop C are brought against the bore and micrometer screwed out until the ratchet clicks. See Fig. 4. On a trial five wheels were calipered and size chalked on wheel in five minutes.

This method of calipering and marking each wheel seat with the points and the further calipering of the bored wheels with the sizes marked upon them permits the proper selection of wheels at wheel seats for mounting, in order to secure the pressures necessary.

As to mounting pressures, your committee recommends the following, in con-

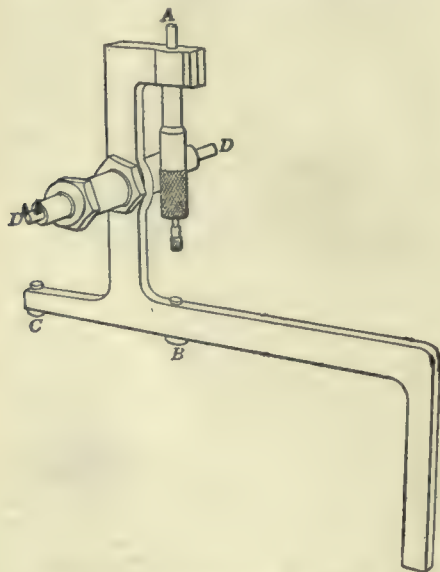

Fig. 3.—Caliper for Wheel-Bore.

junction with the character of workmanship already referred to, as being an essential in the problem.

The following general specifications, which have been quite thoroughly tested, are submitted for consideration.

Axle Wheel Fit.

Must be turned as smooth as possible with lathe tool having flat cutting edge.

Finishing cut must not be taken with lathe feed coarser than 16 pitch. Taper on axle-wheel seat for entering wheel must not exceed one-half in length and must be turned with broad, straight-faced tool, making regular taper without ridges or rings. Wheel fits to be calipered at three points, namely:

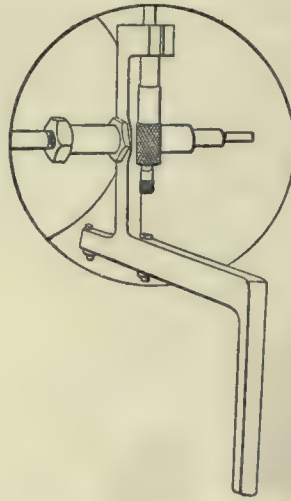

Fig. 4.—Caliper Adjusted to Wheel.

One inch from each end and middle and other points if indications to excessive variations in diameter.

Axles shall not be considered as suitable for mounting where there is a difference in diameter between any two measurements exceeding 0.003 of an inch. This, however, shall not be counted to mean that wheel seats on each end of axle are to be of one size. Each tenth axle from each lathe shall be measured for soundness. No axle varying over 0.001 of an inch when measured at two points, 90 degrees apart on circumference at equal distance from end shall be considered as suitable for mounting.

Wheels.

To be bored smooth. Finishing cut shall be made with tool or tools having a cutting face at least 3-16 of an inch wide. Feed not to exceed 8 pitch. To be bored with a rough and finishing cut. The finishing cutter when taking the finishing cut must not be cutting when roughing tool is also rough-boring, unless the finishing tool is supported independent of roughing tool, the latter to prevent spring of roughing tool being transmitted to finish tool, causing an irregular bore.

Wheels to be calipered with micrometer caliper. A wheel varying over 0.002 of an inch in any two diameters will not be considered satisfactory for mounting.

Mounting presses to be provided with recording pressure gauges. All wheels not mounted within limits given, or wheels that are forced against shoulder to be withdrawn.

One point that may be foreign to the subject should receive attention, which is lathe centres. It would be very desirable if all shops were to adopt one angle. Generally, lathe centres used for ordinary work are 60 degrees, including angle. If this were adopted for all axle work, it would result in the axles running true on centres, reducing the amount of material necessary to turn away when truing up axles that have been previously turned.

USES OF SAWDUST.

Sawdust is usually regarded as an objectionable product because it increases the danger of fire if deposited near mills or lumber piles and necessitates either cartage with accompanying expense or the construction of a "burner" and the use of conveyors or carts to transfer it from the saws.

A double economy, however, is now in process. As a result of the use of band saws instead of the old circular and gang saws, a log that, under the old system produced 8 boards, will now produce 9, a very substantial increase in product with a corresponding decrease in the amount of sawdust produced.

Owing to its chemical and mechanical properties, it has an ever increasing field of usefulness. Used as an absorbent for nitro-glycerine, it produces dynamite. Used with clay and burned, it produces a terra-cotta brick full of small cavities that, owing to its lightness and its properties as a non-conductor, makes excellent fire-proof material for partition walls. Treating it with fused caustic alkali produces oxalic acid. Treating it with sulphuric acid and fermenting the sugar so formed, produces alcohol. Mixed with a suitable binder and compressed, it can be used for making mouldings and imitation carvings; while, if mixed with Portland cement, it produces a flooring material. It is excellent packing material for fragile articles and for dangerous explosives and can be used as packing in walls to make them sound-proof and cold-proof.

William J. A. Bailey, who recently returned from a successful trip around the world representing a number of American manufacturers, is now preparing another business tour. He expects to leave this country early in the fall and will be gone about a year, visiting the leading commercial centres of the world. Mr. Bailey markets his lines in conjunction with permanent sales offices in the different countries so that this trip would no doubt be of interest to manufacturers seeking foreign trade. His address is 32 Broadway, New York City.



The Wood-Working Department at the M.A.C.

Technical Classes in Manitoba Agricultural College

The Reason Leading up to the Establishment of the Course
in Mechanical Engineering at Manitoba Agricultural College.

By L. C. Harkness

In recent years the great farming communities have looked with appreciative interest at the work being done in agricultural colleges. It was not always so. The bluff farmer is prone to believe that those excellencies of skill required in every branch of agricultural work can only be developed on the farm by the practical every-day routine of duty. The old tiller of the soil is reluctant to admit that anyone in a college can teach him regarding any ordinary farm work. But the scene is changing. Not only is the farmer sending his sons to acquire agricultural efficiency, but the old bearded sires are coming themselves.

It is not surprising that the science of grain-growing and expert stock feeding and judging was the first to attract the attention of the agriculturists. It was this branch of study that paved the way for the equally important branch of mechanical science. In Ontario the farm mechanics course of study was obviously more difficult to bring about than the same course in Manitoba. Farms were smaller, market facilities were more convenient, and the comparatively smaller land owner did not feel the urgency of iron and woodworking knowledge, or the training required to construct a building or the ability to repair a gasoline engine. Such knowledge was left quite unmolested in the hands of a few who lived in the towns and villages throughout Eastern Canada,

and who served the "less fortunate" for whatever fee the mechanic cared to levy. In the west it is different. Farmers as a rule are not so convenient to a town or even a neighbor, and often he is urged by sheer necessity to bring his own inventive genius into operation, fertile or unfertile as the case may be.

Establishment of Agricultural College.

So the establishment of an agricultural college near Winnipeg was hailed with

joy, by the great mass of intelligent agriculturists in Western Canada. In less than three years after its opening a strong foundation was laid for a fully equipped mechanical science department. At the present time, one of the finest buildings to be found on the continent, where mechanical science is taught, stands on the college farm. It is 180' x 100' in dimensions, and a three-storey structure. Prof. L. J. Smith, B.Sc., formerly of Ann Arbor, Michigan, took charge of the department in the fall of 1909, and at the outset made some important announcements regarding the future of the great work of which he is a master.

The dominant idea in carrying out the work of the department, which is designated "Agricultural Engineering," is simply to increase the efficiency of the student in the practical work on the farm. The theoretical work is not gone into to any great length during the two first years of the course, but the more highly technical work is only utilized to make the practical efficient. The course in reality covers only two years, but owing to an enlarged idea, a four years' course will be inaugurated, this year (1910), in which the third and fourth years' work will be a continuation into the more advanced stages of the previous year's work. The last two years training is designed to prepare students for pedagogical and government professions.



PROF. L. J. SMITH, B.S.

Head of the Department of Mechanics at Manitoba Agricultural College.

The complete course is divided into six subjects, namely, mechanical building, construction, draughting, carpentering, blacksmithing and sheet metal and pipe work.

The Courses.

The work under mechanics is very far reaching. It involves the study of

patched from thresher works offices or the training school to repair the much needed machine, in order that the great harvest toward which everyone looks with eager anticipation, might not be waylaid.

The study of friction and lubrication of engines and machinery is an import-

livered, and it is evident from the large registration in this course that it is enjoyed and found valuable.

Draughting.

The draughting department is one where a student acquires an adequate knowledge of how to lay out plans for any contemplated construction. He is taught to become his own architect in the erection of farm buildings. In this way a prospective farmer is enabled to "count the cost" before he enters upon what might otherwise prove to be an unwarranted scheme.

The knowledge of carpentering is perhaps the most valuable line of study in this department. Every farmer his own carpenter, is the prevailing need. The far-reaching effects of such a study is not at once perceived. It involves the care of tools; the choice in the selection of tools; the filing of saws, and then on to the practical uses of the tools in their myriad forms. How few know how to use a chisel or saw, and many less know how to match lumber and plane a stick of wood. In this study comes the invaluable training in the judgement of the strength of wood materials.

Forge Shop.

In the forge room the farmer is put to the test as to his ability in iron working. Most of the boys enjoy this rigorous discipline. It is a place not only where good welds are made, but good characters. The boy that stands by his forge and spoils an iron perhaps twenty times before he makes a proper weld is a better man when he is through than when he began.

The value of forge knowledge is manifestly of great value to the farmer. The ability to make hooks, clevises, links, staples, bolts, grab-hooks, etc., is always envied by the farmer, and this, the young son of the soil is taught to do perfectly. One needs not be very imaginative to see a mechanically trained



First Year Class in Blacksmithing and Iron Working.

construction, care and repair of farm machinery. Students are taught to operate gasoline and steam engines, and a superficial knowledge of their construction. Threshers are made a thorough study of, and indeed all training necessary for good expert threshermen, is given.

In the more advanced work of the third and fourth years the science of engine construction is studied in detail

ant factor in this course. The care and cleaning of boilers is given considerable attention, as is also the points of fuel and engine economy. The design and care of agricultural field machinery is by no means a secondary line of study, and this branch is manifestly an important one to those who follow the farming pursuit.

Building Construction.

In the second year an important course in building construction is given. Twenty lectures along the lines of plans and specifications. The construction of roof and bridge trusses; quantity and cost of material; the heating, ventilation and sanitation of buildings, are de-



Model Gasoline Engine Used for Teaching at M. A. C.

as well as the various other branches. This sort of training is considered very important at the present stage of Western Canada's agricultural development. On the distant prairie where there are thousands of acres of wheat waiting to be threshed, it is rather serious when the only threshing outfit available cannot be used, owing to some technical dilemma in its mechanism. It has often happened that experts had to be dis-

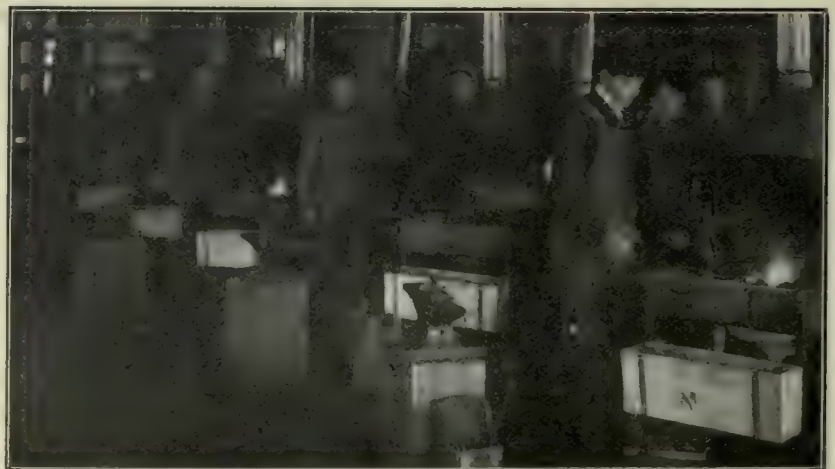

Farmers' Sons at the Forges.

boy rushing home for the vacation to build a forge beside his father's barn and work diligently until he turns out a new pair of clevises.

As civilization advances, the science of metal working and the ability to handle iron pipe will be invaluable to the farmer. Metal roofing is fast replacing the shingle, and windmills and engine pumps with pipe attachments have already replaced the "old oaken buck-

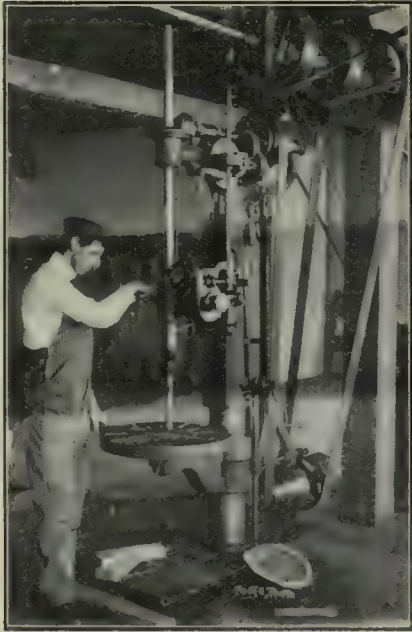

Large Drill at Manitoba Agricultural College.

et." If the young farmer is taught how to solder metal, and cut threads on pipe, he is surely quite in step with the onward march of scientific development.

WHEN TO INSTALL NEW MACHINE.

A question often asked is, "How are we to know when the proper time arrives for scrapping old machinery and installing new?" From the economic standpoint the answer may be stated as follows: It pays to scrap old machinery when the new machines to be installed will, during their useful life, make a sufficient additional profit in one way or another to pay for the cost of installing themselves and all incidental expenses.

Money is easiest made in manufacturing when machines are worked continuously, and as far as possible turning out the same objects. Other things being normal, it is a workshop axiom that the longer a machine is run, producing one article in the greatest possible numbers in a given time, the bigger will be the profit. Displacing an old machine involves checking temporarily the production of a given article or articles, with the result that the burden of expense is shifted and falls unequally on the rest of the departments. Moreover, to have to acknowledge that pending the erection

of new machinery this or that order cannot be executed is calculated to divert trade, which may cost a considerable amount of effort and trouble to regain. Many good orders have been lost through firms not being able to supply a particular article promptly.

It follows then that when changing a machine or altering the methods of producing stock articles, the new machine should be installed, if possible, before the old one is scrapped. This is not always possible. One of the features of modern life is the increasing demand for space and the growing difficulty of finding it. A machine that is one of a series working together could hardly be replaced by another fixed in some other part of the works. The point we wish to enforce in this connection is that all of these chances of loss, or possible necessity for additional outlay, must be taken into consideration when the problem of scrapping a machine or group of machines arises.

The manufacturer then, who contemplates displacing old machinery should draw up a balance sheet showing every likely item of cost and profit, and only when the credit side shows a substantial balance should he venture on a change, unless indeed he has lost, or is certainly likely to lose, his trade without the step is taken. That, however, is exceptional and outside the present argument.

On the outlay side of the balance-sheet indicated must be put down the cost of the new machine, freight, charges for packing, and the cost of fixing it. In addition to this, the probable loss during the period of change should be carefully estimated. This last may prove a serious charge, unless the manufacturer is lucky and manages to get in the new tool during a slack period. Due thought should also be given to stock in hand, because one result from a new machine will be the output of the articles either better in appearance than the old, or at a lower first cost. If the new article is smarter than the old the latter become a drug on the market, and may even have to be scrapped themselves. A safe rule in such case is to take the worst possible view of things.

On the other side of the account should be set an estimated sum likely to be realized by the sale of the old machine. It is wise not to take too rosy a view of the set-off on this count. If it is sold for old metal it may have to be dismantled and carted to the auction rooms or to the metal dealer's premises, with attendant expense at every stage.

The next point on the credit side of the balance-sheet to be estimated is the probable amount of increased profit that can be realized by the use of the new machine. Increased profit may arise in

two ways—from decreased cost of manufacture or from increased price obtainable, along with the probable sales at the increased profit. These are difficult points to decide, but the next is perhaps the hardest of all to determine—the estimation of the probable useful life of the new machine. There appears to be no rule that can be taken as a guide for this. The life of the old machine affords little or no help, because it usually represents a different period of development. It is wise not to take too rosy a view of the possible life, for modern machinery develops at a rapid rate, and what may be up-to-date this year may be too expensive to continue in use twelve months ahead. The estimate of the probable profits during each year upon the articles turned out by the new machine, multiplied by the estimated number of years, will give the total profit that may be hoped for from the use of the new machine. When this exceeds by a fairly substantial sum the amount on the debit side of the account representing the cost of installing the new machine, with all attendant losses, it should be safe to scrap the old machine.

ROYAL COMMISSION ON TECHNICAL EDUCATION.

The commission on its tour through the Maritime Provinces, has stopped at several cities gathering information. At North Sydney, N.S., where considerable progress in technical education has been made, an extended investigation was entered upon. The chief industry of the place being the coal and steel plants of the Nova Scotia Steel and Coal Co., technical education had become very much of a necessity. Several of the officials on the engineering staff were in the habit of assisting by teaching these night classes themselves. All of these officials were called upon to testify before the commission and from them many valuable suggestions towards the work of the commission were gleaned.

The Russell Machine Co., St. Catharines, who were burnt out some months ago, are now in their new factory, which is fully equipped with all the latest machinery. The firm is prepared to give estimates for all kinds of work, and will guarantee workmanship and quick delivery.

The foreman of a certain railroad boiler shop carries his requisition pad in a tin box of the dimensions of an ordinary check. Thus the blanks are kept clean, smooth and unworn at the corners. The box gives a solid writing surface for the many requisitions that must be filled out during shop hours.

The Scientific Lighting of Factories and Offices

By Recent Advances in Illumination, Better Lighting May be Had at Less Cost than Formerly, adding to the Comfort and Efficiency of Employees.

The proper lighting of factory and office is often neglected by manufacturers. With the many recent advances made in illumination it is well worth while investigating the question of illumination. In the office and in the machine shop there should be good lighting for the employees. Some Canadian factories have made installations greatly decreasing their light bill.

The new tungsten (Mazda) lamp consumes only 14 watts per rated candle power compared with 3 to 4 watts per rated candle power with the carbon filament lamp. Thus three to four times the same light with the same current consumption. Thus 16 candle power Mazda lights may be used where 16 candle power carbon filament lights were formerly used without increasing the light bill.

R. B. Basham, vice president and general manager of the Canadian Tungstolier Co., 96 King St. West, Toronto, designed a system of lighting for the offices of the Massey-Harris Co., Toronto, which is making a large saving for that company.

Fig. 1 shows a corner of one of the offices where Sunbeam Mazda lamps installed in the anti-vibratory Tungstolier, give a very even distribution. In

the Tungstolier all vibration is absorbed and there have been no burn outs though the system has been in use for some time.

Proper reflectors add to the efficiency of the system. By this means the light falls where it is needed and this is another point in favor of scientific illumination.

In making the installation the various offices were measured and from this the required amount of light was figured out. This decided the number of fixtures. The correct reflectors were then



Fig. 1.—Advertising Office, Photo Taken With Light of Mazda Lamps. Note distinctness of detail and Photos.



Fig. 2.—A Machine Shop, Showing General Illumination from 100 Watt Tungsten Lamps with Holophane Intensive Reflectors.

decided upon and the final result shows that the whole installation has been well designed and there are no shadows.

Factory Installations.

Fig. 2 is a view of a machine shop showing the general illumination from 100-watt Mazda lamps with peloplane intensive reflectors. Fig. 3 is another view of general illumination using 100-watt Mazda lamps. In the three views shown there is a great deal of vibration but in all cases it is well provided for to protect the fragile tungsten filament.

Fig. 1 clearly shows the anti-vibration tungsten which makes the use

space to be illuminated must be considered as well as the walls and special attention must be given to the reflector. Different reflectors have been designed for general illumination and for the lighting of work. Using the same reflector for both will result in lost light.

If a workman is employed at a machine the light must be focussed on his work and reflectors should be used that will deliver the proper light rays at the proper angle. This angle should be 15 to 30 degrees, or it should be focussed to within 15 degrees of the perpendicular, depending on whether it

of an emery stone is of considerable importance. The light must be placed so that not only the face of the wheel but the edges can be properly lighted. This can be done by means of a proper reflector and so throughout the whole shop, the lathe, the planer, the shaper, the miller, the boring machine, etc., can all be properly lighted if the right reflectors are used. A careful consideration of the question of factory and office lighting will result in better illumination and a saving of current.

SOUVENIR PAPER KNIFE.

An unique paper knife has been designed by the manufacturers of Shelby Steel Tubing. As it is made from a piece of the tubing it is a practical demonstration of how this material can be used. John Millen & Son, 321 St.

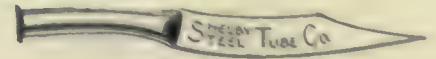

Souvenir Paper Knife.

James Street, Montreal, the Canadian agents of the Shelby Steel Tube Co., offer to send one of these paper knives to any reader of Canadian Machinery who will write for same on their business stationery. With the paper knife will be mailed some interesting literature on Shelby Steel Tubing.

NEW KIND OF STEEL INTRODUCED.

At Chester, Penn., a new kind of steel is now being manufactured under the name of "cementation steel." It is of the high carbon variety, but contains more sulphur and less manganese than ordinary tool steel. The steel is so dense that it remains unresolved under the microscope with a magnification of 1,200 to 1,600 diameters, although that of the open hearth, crucible and Bessemer steels can be resolved with a magnification of 100. Its elastic limit is said to be very high and its ultimate strength 80,000 pounds. It is intended specially for cast gears, crank shafts, connecting rods and so on. The process of manufacture takes from six to eight weeks.

CELFOR DRILL SPEED CARD.

The Celfor Tool Co., Buchanan, Mich., are mailing to machine hands on request a table of feeds and speeds for Celfor drills. This is mounted on heavy cardboard and is well suited for use in the machine shop.

John H. Tilden, for many years president and general manager of the Gurney-Tilden Co., is retiring from that position, on the re-organization of the firm.



Fig. 3. General illumination of a factory obtained from a double row of one-hundred-watt tungsten lamps, provided with special distributing reflectors and hung on short drops from the ceiling, as illustrated. Special steel reflectors, each provided with an eight-candle-power carbon lamp, direct the light at the machines.

of the tungsten filament lamp possible in factories, offices and any other place where there is a great deal of vibration. The tungsten lamp, of course, will burn practically wherever the carbon types are used, but by protecting it from jar, better results are obtained.

Importance of Reflector.

The vibration provided for, the next item in scientific illumination is the reflector. The custom of putting a light here or there irrespective of whether it gives the best light or not, is not only unscientific but it is uneconomical. The

is for general or special illumination. The point is that the light should be delivered where it is required, thus securing correct illumination with often a less consumption of electricity. In scientific illumination as much attention should be given to the reflectors and diffusion as to the light source itself.

Employers should therefore realize that a skilled workman's value as a producer is dependent on the tools he uses, as has been stated above. In the case of a machinist it means properly sharpened tools and hence the lighting

Comparison of Wearing Surfaces for Factory Floors

Relative Merits of Granolithic and Wood Top Surfaces for Factory Floors,
Abstracted from a Large Number of Enquiries among Factory Owners.

Much has been said regarding the various flooring surfaces used in fire-proof buildings, comparison usually centreing in a choice between granolithic surface and a wood top laid on concrete floor slabs. The reports of the experience of owners with granolithic finished floors have not clearly given the causes of success or failure of the particular floor under particular conditions. There is also a marked lack of information and experience concerning other wearing surfaces, which in some cases might be preferable.

In order to obtain the fullest possible testimony from engineers and manufacturers as to the relative values of granolithic and other substances for floor surfaces, the Aberthaw Construction Co., of Boston, Mass., sent letters to some two hundred engineers, machine shops, paper and textile mills, and other large establishments in the region north of Baltimore, and east of the Mississippi, asking for their opinions as to whether they considered granolithic or masonry surfaces injurious to operatives, and if so the reasons why; and whether they knew of any better floor surfacing.

One hundred and eighteen replies were received which related varied experiences with the different substances. As 68 p.c. of the replies were from machine shops we will consider those for the other establishments heard from were pretty evenly divided. Of this 68 p.c., 27 p.c. had had no experience with granolithic, 25 p.c. were in favor of it, while the larger number or 48 p.c. reported more or less unfavorably on it, from its bad effects on operatives, and its poor wearing quality. Most of the testimony regarding the wearing capacity seems to bear out the statement that a large proportion of the bad effects was due to poor workmanship in laying improperly, and that when properly laid it was satisfactory is borne out by the favorable 25 p.c.

Granolithic Floor.

Under certain conditions, however, it is clear that the granolithic floor has an unfavorable effect on the comfort, and perhaps to a small degree on the health of operatives who have to stand inactive for long periods, as for instance, in tending a machine. The real cause of workmen's complaints is undoubtedly due to the coldness, rather than the hardness of the concrete floors. This arises from the high conductivity of concrete, as compared to wood, making the former appear much colder than

the latter, so that, in cold weather when the concrete is in outward contact with the ground or cold air, it actively withdraws heat from it under surface, thereby making it cold. Besides, its high specific heat causes it to remain cold longer than its surroundings, from its inability to heat up as quickly. The effect of the rapid heat conduction on the operative is to slow the circulation, often giving rise to sore feet, where the pressure of the body comes on the ground. Lameness and stiffness of the legs are logical results in some cases. Moisture aggravates these conditions.

Two remedies for these bad effects were discovered. One of these consisted in the use of small movable gratings of wood or other material having low heat conductivity, for the workmen to stand on, and the other was the actual heating of the floor itself by means of contained steam pipes or hot-air ducts in the substance of the floor-slab. Cases have been cited where the whole place was heated by the above method. Where these devices have been introduced, no complaints from operatives are heard, conveying the fact that it was the cold that was objectionable.

The complaints regarding wear are four-fold: liability to rut under heavy trucking, presence of dust due to abrasion, difficulty of repairing floors, and finally, the trouble of attaching machines to the floor.

Trucking.

Trucking is the most serious cause of wearing, and when carried on extensively will result in considerable rutting, especially if the floor is marked into squares, as the edges break and wear back. The common, flat-thread truck wheel acts like a cutting tool at the edges and when carrying considerable weight the very hardest substances will give to it. This is aggravated when the truck is turning a corner, for a better cutting edge is then presented. It would appear to be readily remedied by slightly convexing the thread. This would decrease the wear quite considerably. Enlarging the size of the slabs tends to decrease the wear at the edges, and some we recommend doing away with the squaring altogether. Cracks will occur, and whether they are straight or otherwise matters little. The uncut floor is said to give much better wear, as well.

In paper mills, and in some other factories where heavy trucking occurs, nothing but iron or steel will bear up

under the pounding and cutting of the truck wheels. Cast iron plates and steel racks, embedded in the soft finish concrete, have been successfully used for that purpose. The steel plates are commonly made fifteen to eighteen inches square, with checkered surface, and with a flange which turns down around the edge of the plate, a hole being left in the top for the escape of air. The plate is pounded into place with a mallet, and levelled, the cement bond holding the flange securely. A cheaper, and equally satisfactory arrangement has been the embedding of racks of small flat bars, separated by thick washers and bolted together. They are set flush with the surface, and take the truck wear satisfactorily. It is inadvisable, when using plates, to bolt them down, as then the expansion of the plate, due to wear, has a tendency to buckle them up.

The trouble from dusting appears to arise wholly from faulty material and workmanship, for with these corrected, a dustless floor is quite possible. The fact that wood floors will not show dirt readily, and will, even under the worst conditions, add no grit to the situation, is a decided point in their favor. In metal-working shops, or in shops where machinery with delicate bearings is to be used very great care must be exercised in order to get an entirely satisfactory floor of cement, and because of the uncertainty of having all conditions thoroughly favorable to this, a wood-top floor is oftentimes the wisest policy. With a poor concrete floor, at the best, but a temporary relief may be obtained by the use of paint, or of boiled linseed oil which has been thinned with gasoline or naphtha so as to permeate the pores. The latter is the better way, and has the advantage of being waterproof as well if the floor is porous.

Wooden Floor.

Wooden flooring is much preferable when the item of repairs is considered because of the difficulty of bonding new cement to old. This item is, however, small as but slight repairs are required with concrete.

Wooden floors are also more advantageous when machines have to be attached, as the expense and labor of so doing is much less with wooden floors than with cement. This advantage is not so prominent as to make much difference.

A very important feature is the liability to fracture of machine parts, if allowed to fall on a cement floor, and which, if let drop on a wooden one, would merely dent the floor. If the article to be manufactured is fragile, wood top floors are preferable.

Considering the relative water-proofing qualities it can at least be said that a wood top floor receives no good from a wetting, and, as seldom any provision is made for waterproofing the concrete below, there is usually trouble with water. A granolithic floor needs to be trowelled hard to be durable, and this trowelled surface is practically waterproof, with no leaking except at joints, and at such spots as have been worn.

Cost.

As regards cost, a one-inch trowelled surface of cement finish can be put in place for about the cost of good quality maple top flooring, delivered on cars at the site of the work. The difference in cost between the top floor of cement and that of wood will be the cost of the under floor, the screeds and cinder, or other fill between the screeds, plus the cost of the extra strength in columns and girders required to carry the load of combination wood floor, which is heavier than the one-inch granolithic finish. This is partly due to the fact that, if the granolithic surface be laid when the under floor is green, the surface is made an integral portion of the floor slab taking up part of its strains, and by so doing, permitting of a lighter slab than is required for a wood top. On the other hand the wood floor and accessories form a dead load. It would therefore seem, that from the point of view of cost, the granolithic is better.

It also appears to have the advantage as regards quickness of construction, for the granolithic floor may be laid immediately, whereas the wood top must await the drying out of the floor thoroughly, as it would otherwise warp, and maybe have the rot set in.

REMARKABLE GAS BLAST FURNACE.

By Frank C. Perkins.

For hardening dies and tools as well as for annealing and other similar service a unique furnace of the type shown in the accompanying illustration is utilized to advantage, no bellows or air compressors being necessary. Gas and water only are utilized the gas consumption being about 65 cubic feet per hour. A water tank is hung seven or eight feet above the burner and a rubber tube connected between the furnace and the tank, a $\frac{1}{2}$ -inch gas hose being attached to the furnace. After lighting the oven becomes hot in about 10 minutes when it is ready for service.

It may be stated that oxygen and hydrogen gas in connection with the open flame will raise the temperature of the flame to a very high degree. Water consists of two parts, hydrogen and oxygen, if converted into steam and

superheated, thereby becoming dry, it will be a combustible vapor when fed to the flame. Air is composed of approximately four parts of nitrogen and one part of oxygen. By forcing it into the flame, as for instance, with a bellows or on a smaller scale in the Bunsen burner, the mixed elements will burn with a raised temperature. To force air into a burner has hitherto been accomplished either with a bellows or a mechanically driven compressor.

The "Revelation" gas blast is based and constructed on the above scientific principles. Broadly stated it consists of devices for generating a combustible vapor under pressure, such as steam,

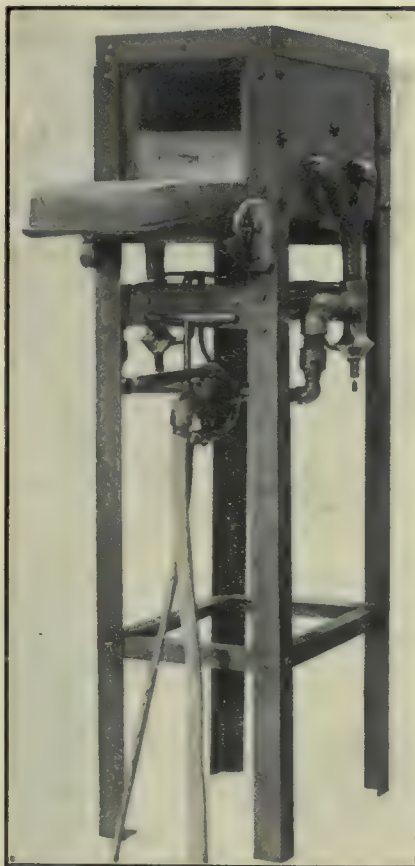

Remarkable Blast Furnace.

utilizing the vapor pressure for entraining air, thus producing a mixture of gas, vapor and air, and igniting the resulting mixture of these components, producing an intense heat by the consumption of low pressure gas fuel.

It is claimed that the construction of the "revelation" gas blast process is so simple that one cannot help wondering as the strong and sustained blast produced with the aid only of a small tank of clean water suspended about 8 feet above the appliance and connected by quarter-inch rubber hose.

It is held that the principle involved in the construction of the apparatus here illustrated is a radical departure from that of the familiar gas blasts now in use.

To a Bunsen burner is attached what may be called a steam generator, consisting of two tubes running parallel with the Bunsen. A smaller tube attached to the top of the generator serves to carry the superheater steam to an injector. Small perforations in the "Bunsen" tube keep the generator under a continuous heat sufficient to convert a fine film of water into superheated steam which is forced out of the nozzle of the injector under high pressure, thereby entraining air by suction of the steam pressure.

There are three components, viz: air, gas and steam which, being dry is converted into a gaseous fuel containing hydrogen and oxygen, and are closely mixed and issue from the burner nozzle as a powerful blast capable of melting silver, gold and copper.

PERSONAL NOTES.

W. H. Carriek, general manager of the Gurney Foundry Co., is severing his connection with that firm, to take up the position of president and general manager of the Hamilton Stove & Heater Co., which is the re-organized Gurney-Tilden Co.

C. J. White, of Toronto, is now residing in Prince Rupert, B.C., where he will represent several manufacturing firms for the sale of machinery of all kinds. Mr. White has had an extensive experience as salesman and should prove to be a good representative in the new country.

James Reid, Wilson, and K. W. Blackwell, of Montreal, have been appointed to the board of the Nova Scotia Steel Co., to fill vacancies created by the retirement of Messrs. Reford and R. E. Chambers. The retirement of the latter is said to be only temporary, due to his absence in Brazil, examining some iron ore property.

James R. Wilson, and K. W. Blackwell has joined the board of the Nova Scotia Steel & Coal Co., in the place of Robert Reford and R. E. Chambers, who resigned recently. Mr. Wilson is on the board of the Dominion Steel Corporation and a director of the Montreal Steel works. Mr. Blackwell is a practical iron and steel man, being president of the Montreal Steel works.

J. P. Fillingham, until recently assistant superintendent of the Reo Factory, Lansing, Mich., has been appointed general superintendent of the Reo Motor Car Co., St. Catharines. Mr. Fillingham, who has been for the past ten years engaged in the manufacture of automobiles designed by R. B. Olds, is a native of Canada, and received his early mechanical training in the Watrous Engine Works, Brantford.



Filing Catalogues to Secure the Greatest Benefit

One problem more or less serious ac-treated here were the result of this effort. According to the size of the business, and the systematic proclivities of the man in charge of the buying, that is under discussion in many manufacturing business-

Catalogues come in all shapes, sizes and thicknesses. Where and how to keep them for easy reference is the question. In the course of a year several hundred catalogues and price lists will probably be received from manufacturers and wholesale houses. The purchasing agent or the buyer must refer to these catalogues and price lists numerous times every day, and unless he has lots of time to spare, he must keep these catalogues on file in a convenient place, where he has only to reach out his hand and secure the catalogue wanted, without distracting his mind from his work, or in wasting time and energy fumbling through desk drawers and other places.

The basis of this catalogue filing system is the two card index forms illustrated in Fig. 1. These two forms are the index by which every catalogue and the articles listed in each catalogue can

be found. Sectional vertical filing cabinets are particularly adapted for filing catalogues, on account of the different sizes in which the drawers are made. Card index sections are in reality simply small sized vertical drawers. The card index and the vertical system of filing are both based on the same principle of filing cards or papers upright on edge, behind heavy pressboard guides.

This is illustrated in the stack of sectional cabinets shown, Fig. 2. In the top section are the index cards filed under both makers and subject guides.

In the next section which is the 6 in. x 4 in. card index section are filed small price lists, and below this is another card index section size 8 in. x 5 in. for larger price lists and small catalogues. The next section is the bill size vertical, containing three drawers for catalogues not larger than 7 in. x 9 in., and the bottom section is the letter size vertical, 25 in. deep which will take catalogues 9 in. x 11 in., and if a larger section is re-

Two card forms for indexing catalogues. The top card is a subject index card with fields for 'SUBJECT', 'NAME', 'ADDRESS', 'DR. NO.', 'DAY', 'PAGE', and 'PRICE'. The bottom card is an article index card with fields for 'ARTICLE', 'PRICE', and 'PAGE'.

ARTICLE	PRICE	PAGE
Large Coated Paper		
Small Coated Paper		
...		

Fig. 1.—Card Forms for Indexing Catalogues.

es, is how to file catalogues, so that they can be quickly and easily found when wanted.

This company went all through this trouble of filing catalogues years ago, and determined that some method must be found by which catalogues from other manufacturers, to which reference was made frequently, should be designed, and the catalogue cabinets which are illus-

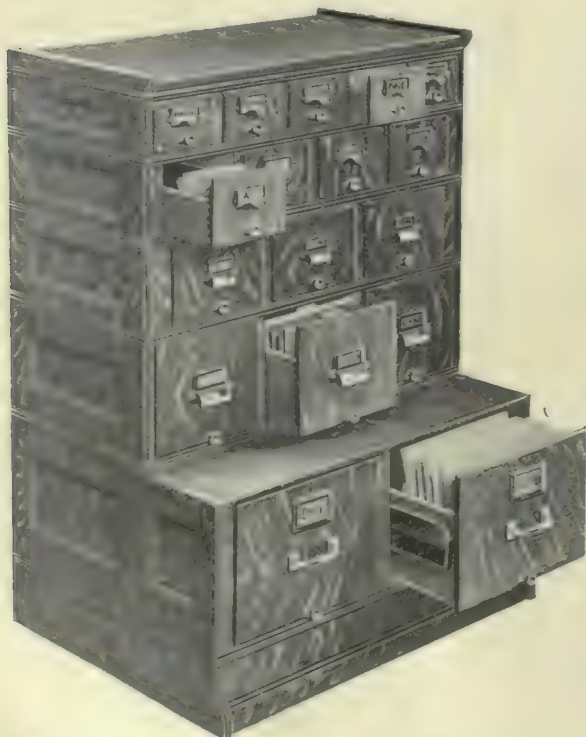

Fig. 2.—Cabinet for the First Method of Filing.

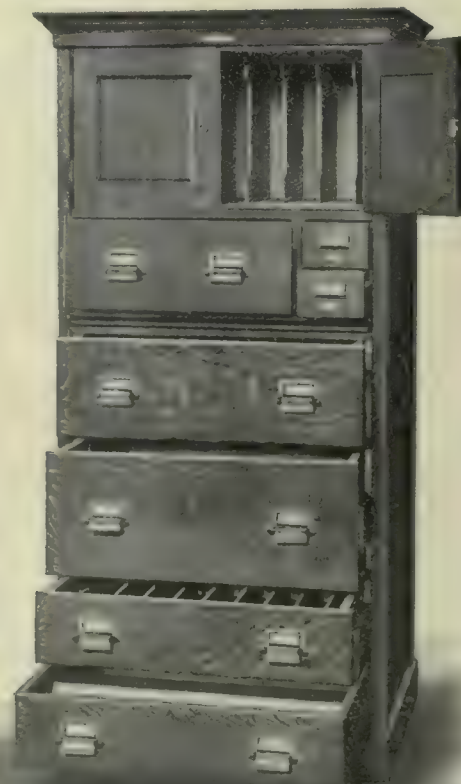

Fig. 4.—Cabinet for the Second Method of Filing.

quired the cap size vertical will take catalogues 9 in. x 15 in.

The method of filing the catalogues and price lists for quick reference is very simple. Each size of drawer is known by a letter. The 6 in. x 4 in. drawers in the stack illustrated are "A," and each drawer in the section is further subdivided with a figure, as A1, A2, A3 and A4. The next largest size drawer is "B," the next "C," and the next "D," each of which also has a supplemental figure. The guides in the drawers are numbered by tens, so that the first catalogue filed in A1 drawer will be known as A1, No. 1, and as there will be only 10 catalogues behind each guide reference is both quick and easy.

This catalogue system may be started with a single vertical drawer, and if there are only a few catalogues to be filed, a card index will not be necessary, but when the catalogues accumulate to completely fill the vertical drawer it is best to have a card index by both makers' names and articles. This index can be kept in a special card index tray, but it is better to have a card index section in the same stack, as the vertical sections.

If a large number of catalogues are to be filed, it would be wise to select filing sections with drawers of graded sizes, so that there will be no waste room. Small catalogues are more easily located and kept in good condition in small drawers than if catalogues of all sizes are filed in a large drawer.

A Second Method.

There is another method of filing catalogues which is required by many business houses. This company recog-

ning catalogues, in which the drawers were made of various depths, and each drawer was subdivided into pigeon-holes. These pigeon-holes were also made in various sizes, so that a catalogue of any size could be readily filed away.



Fig. 5.—Detail of Subdivided Drawer.

The method of indexing is similar to that explained before, each drawer of the cabinet is known by a letter, such as "A," "B," and so on. Each compartment in the cabinet is numbered beginning with one. The stalls in the cupboard are numbered, 1, 2, 3, 4, etc., and these numbers are continued throughout the cabinet, so that the last compartment in the second lowest drawer is number 164. The bottom drawer has no divisions. It is used for filing extra large books.

When a catalogue is received the size of the drawer and the compartment in

in columns provided for that purpose. These cards are filed in the two 5x3 card index drawers, behind alphabetical guides which may be supplemented by subject guides if desired.

To find all the catalogues of a certain line of goods it is a simple matter to open the index drawer by makers' names, and glance behind the alphabetical guide under which the principal part of the maker's name comes. On this card will be found the drawer letter, and compartment number where the catalogue or catalogues will be found, or if you want to turn up all the catalogues of makers of one article, such as coated paper, the cards with the names of the different makers will all be found in one place in the subject file.

Fig. 5 is a detailed view of the interior of one of the drawers in this catalogue cabinet. The numbers are stamped on the partitions above the compartments.

CHANGE OF RATE CARD.

The following card is useful for informing the proper parties about a change in rate in the machining operations of certain castings. If a new pattern is made necessitating a change in price the card is filled out similar to the one shown.

The foreman fixes the price and sends it to the superintendent for approval.

FORM 220. 2-01-10.	MACHINE	<i>Sloper</i>
NAME	<i>Engine Base</i>	No. <i>216A</i>
Make change price for	<i>Drumming Base</i>	
Above Piece from	<i>\$16</i>	per 100 to <i>\$18</i> per 100
From	19	
For these reasons, viz:	<i>New pattern</i>	
Work on above piece corresponds to work on Piece No.	<i>17A</i>	
NAME	<i>A. Frank</i>	
Foreman Dept.	<i>M</i>	Approved <i>R. O. R. Supt. Mar 1910</i>
NOTED	<i>S. Time-keeper Mar 1910</i>	<i>A. B. F. Cost-keeper Mar 1910</i>

Change of Rate Card.

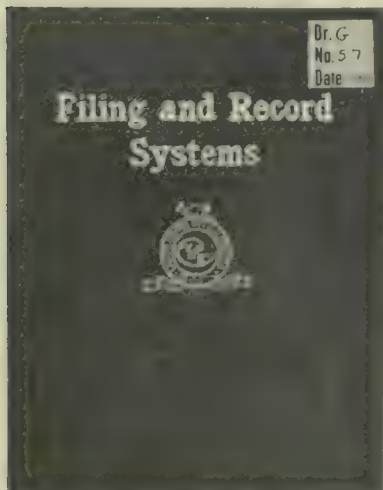

Fig. 3.—Labelled Catalogue Ready for Filing.

nized the need of a simple and practical catalogue file a great many years ago, and as vertical filing was then in its infancy a special cabinet was designed for

which it will most conveniently fit is determined, and a gummed sticker is affixed to the front cover of the catalogue. See Fig. 3. The two index cards are then written out for the catalogue, one with the subject, and the other the maker's name. See Fig. 1. The drawer number and the compartment number are placed on the maker's card in the upper right hand corner. On the subject cards the drawer number, compartment number and page number on which each article in the catalogue will be found are placed on the right hand side

If satisfactory he initials it and passes it to the time-keeper who makes a note of it passing the card to the cost department where it is filed for reference.

This card is used in machine shop, erecting shop, wood shop, foundry and in the various departments where work is done on a piece work basis.

R. B. Angus, of the Montreal Steel Works, has been appointed president of the Bank of Montreal, in place of Sir George Drummond.

MACHINE SHOP METHODS ^A_N^D DEVICES

Unique Ways of Doing Things in the Machine Shop. Readers' Opinions Concerning Shop Practice. Data for Machinists. Contributions paid for.

SLOTTING BAR.

By H. Howard.

The bar shown in the accompanying sketch was designed by the writer for a 32 inch slotting machine, which he operated for some four years in England.

1 is the bar, 6-inch in diameter, attached to the slotting machine ram; 2,

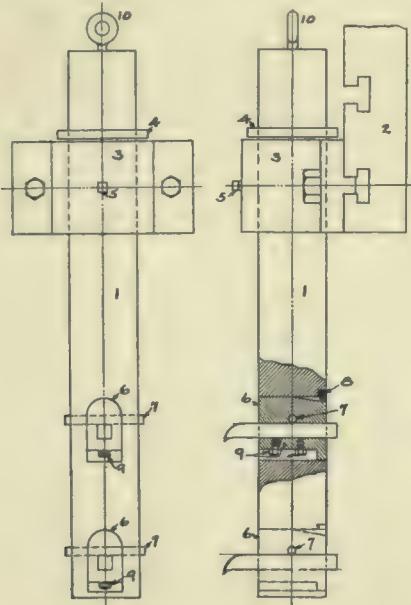

Slotting Bar.

by the bar holder; 3, the latter two being held together by two 1½-inch bolts. Adjustment of the bar was permitted by adjusting the set-screw 5, the weight of the bar being held up during the setting period by the collar 4. 6 is the tool holder held in the cut out bar by the pin 7, and capable of allowing the tool holder to turn slightly on the up-stroke, against the spring 8. The tool itself is held in the tool-holder by set screws 9, as shown, the tool being first put in its holder, and the latter slipped into the bar. An eye bolt 10, at the top of the bar, makes the removal of the bar an easy matter.

As shown, the bar has only two tools, while as originally made it had three, designed to slot a complete set of marine crank webs in one operation. The 6 webs being set up in pairs, a set of 2-inch parallels were placed between each pair, so that a complete set could be machined in one operation with the same expenditure of time as for a pair.

As the bar is round, it may be adjusted as desired to suit the work, requiring no adjustment of the machine ram which is usually difficult to move.

INSERTED TOOTH REAMERS.

The London Machine Tool Co., Hamiltion, have an especially good inserted tooth reamer that they use in their own works, one which was devised by their foreman toolmaker. Fig. 1, gives an idea of its construction.

Essentially, it consists of a machinery steel body, milled to receive inserted high speed steel blades, the latter held in position as shown, by countersunk cap screws, engaging with a notch in the

solid type, with the exception of the adjustable feature. The same rule regarding the number of blades is used. The recesses in which the blades fit, however, tapers at an angle of 10 degrees, while the cut-out for the cap screw in evidence in the solid type, is replaced by a corresponding groove, parallel with the bottom of the blade recess. This is shown in the end view of one of the blades at A. The upper end of the shell of machinery steel is threaded, small pitch, and has two knurled nuts, the inner one of which cupped at an angle of 60 degrees, and fits against the similarly fixed ends of the blades. By loosening the tightening cap screws, and turning the

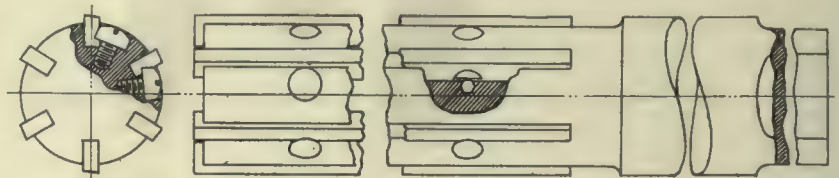

Fig. 1.—Inserted Tooth Reamers.

side of the blades. The beauty of the construction lies in the fact that standard bar stock may be used in the blades. When new, they are screwed down and ground to the desired size, which is ¼ inch larger than the body, allowing 1-16 inch clearance all around. When re-grinding becomes necessary, paper packing, or when that is not enough, tin foil, and even sheet tin may be used, as much as 1-16 inch wear being permissible before new blades are required.

A standard construction has been adapted. In sizes up to 2 inches, 6

inner knurled nut adjustment of the reamer is very readily made and locked by the outer nut, making adjustment for re-grinding an easy matter.

The principle of the construction is excellent as is evidenced by the number of reamers of this type and of the solid type, in actual service at these works.

CENTRING DEVICE FOR BORING.

The C.P.R. shops, West Toronto, use a neat little scheme for rapidly aligning a connecting-rod, or side-rod, end for re-boring.

The end of the rod is placed on parallel strips on the mill table, and the height of the overhanging end adjusted

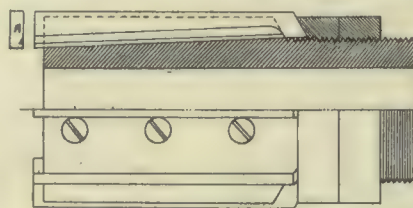
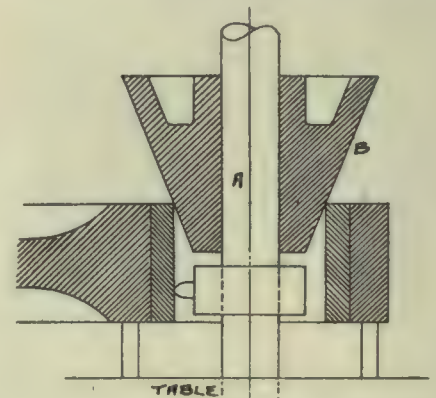

Fig. 2.—Inserted Tooth Reamer.

blades are used; while over 8 blades are required. Under 1½ inches the blade stock is ⅜" x ¼"; while over 1½ inches, it is 3-16" x ⅜". The cap screws are 10-24, their axis passing slightly to the left of the centre of the reamer, so as to clear the bottom of the blade.

Fig. 2 shows an adaption of the same principle to an adjustable shell reamer, much the same in construction as the



Centering Device for Boring.

until the rod is level, when the boring-bar is placed in position. On this boring bar A, is a tapered drum B, free to slide on it, and capable of being set in any position by a set-screw, so that when centring the job, the boring bar with tool in position need not be disturbed. This drum B is lowered into the hole and the job adjusted until it touches all around the drum, signifying that it is now located centrally. When the job may be bolted down. The drum B can then be lifted up out of the way and set, while the job is being bored.

Very rapid work can be done in this way, and while it is used on this class of work, the principle could be applied to other work equally well.

FEEDS AND SPEEDS.

No arbitrary standard of cutting speeds and feeds per revolution or per inch can be established for drills. Not only do the physical and chemical characteristics of the material being drilled affect the proper rate of drilling, but the strength and condition of the drilling machine and the shape and degree of sharpness of the drill point also have great influence; therefore, much must be left to the judgment of the mechanic. The following table, prepared by the Celfor Tool Co., Buchanan, Mich., will serve as a guide for Celfor drills under average conditions. In many cases, if the drilling machine is strong and accurate, and the drill is sharp, rates for above those given in this table may be obtained in regular practice. In tests, our men frequently attain to double and treble the rates given in this table.

The necessity for careful and frequent grinding to secure economical and satisfactory results in the use of our drills must be emphasized. The point should be reduced to proper thickness by grinding it evenly on each side, and the two cutting edges should have the proper angle, the proper clearance, and should be precisely alike; that is to say, the point of the drill should be absolutely symmetrical.

Any drill which is run too fast will burn on the corners. The maximum safe cutting speed, in general, is independent of the rate of feed, but in hard materials drills will burn at smaller feeds (at the same speed) than in soft materials. The following table is laid out for a cutting speed of 100 feet per minute in cast iron, 60 to 80 feet per minute in medium steel, and 40 to 60 feet per minute in hard steel. The torsional strength of the larger drills will permit of far greater feeds than those given in this table, but due regard has been given to the capacity and rigidity of available drilling machinery in constructing this table, the object being to give practical, rather than theoretical figures.

It is essential to keep the drill point properly shaped and sharp in order to give best results. Sharp drills economize time, power and drills, and drill better holes.

ROUNDING ENDS OF PINS.

By Herbert E. Chittenden.

Having a batch of 100,000 button-head pins to form to a nicely rounded point it was necessary to devise some

quick way for doing the work. Our chamfering machine is a home product, being made from the bed of a single-head threading machine fitted with a sliding head operated by a foot treadle and driven by a cone pulley. The head, as is seen by Fig. 1, is fitted with formed cutters, which can be ground on the end and adjusted to position by the fillister-head screws shown.

To make the cutters we saw them to length from a bar of $\frac{1}{2}$ square Novo steel, put them in the slots in the head, fasten on the steel plate (shown in section 1) by means of three 5-16 counter-sunk screws, put a piece of $\frac{1}{4}$ round

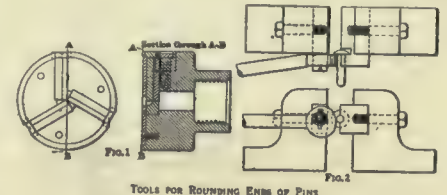

tool steel, which has been turned and fluted to the shape of the point of the finished pin, in the drill press and drill down in the blank cutters the depth required. Then we take out the cutters and shape them down their full length to the shape formed by the drill.

The vise is of the ordinary threading-machine pattern and is bolted to the bed, but can, of course, be shifted to various positions to accommodate different lengths of stock. The vise is fitted with cast-steel jaws, as shown by Fig. 2. The eccentric gripping lever is made from $\frac{1}{2}$ round tool steel and fluted similar to a pipe wrench. Any turning

DRILL SIZE	CAST IRON OF AVERAGE QUALITY			MEDIUM STEEL			HARD OR VERY TOUGH STEEL		
	R. P. M.	FEED		R. P. M.	FEED		R. P. M.	FEED	
		Inches per rev.	Inches per min.		Inches per Rev.	Inches per min.		Inches per rev.	Inches per min.
$\frac{1}{8}$	1500	.010 to .015	15 to 23	1200	.008 to .012	9 to 14	600 to 900	.006 to .008	3½ to 6
$\frac{3}{16}$	1000	.012 " .020	12 " 20	800	.008 " .012	6 " 9	400 " 600	.006 " .008	2½ " 5
$\frac{1}{4}$	750	.015 " .025	11 " 19	600	.010 " .015	6 " 9	300 " 460	.008 " .010	2 " 4½
$\frac{5}{16}$	500	.015 " .025	9 " 15	500	.010 " .015	5 " 8	220 " 360	.008 " .010	2 " 3½
$\frac{3}{8}$	500	.018 " .030	9 " 15	400	.010 " .020	4 " 7	200 " 300	.010 " .012	1½ " 3½
$\frac{7}{16}$	440	.018 " .030	8 " 13	350	.010 " .020	3 " 7	180 " 260	.010 " .012	1½ " 3½
1	380	.018 " .030	7 " 11	300	.010 " .020	3 " 6	150 " 225	.010 " .015	1½ " 3
1½	340	.020 to .030	7 to 11	270	.015 to .020	4 to 5½	140 to 200	.012 to .020	1½ to 4
1½	300	.020 " .030	6 " 9	240	.015 " .020	3½ " 5	120 " 180	.012 " .020	1½ " 3½
1½	275	.020 " .030	5½ " 8	220	.015 " .020	3 " 4½	110 " 165	.012 " .020	1½ " 3½
1½	250	.020 " .035	5 " 8	200	.015 " .020	3 " 4	100 " 150	.012 " .020	1½ " 3
1½	235	.020 " .035	5 " 8	185	.015 " .020	2½ " 3½	95 " 140	.012 " .020	1 " 2½
1½	220	.020 " .035	4½ " 7½	170	.015 " .020	2½ " 3½	90 " 130	.012 " .020	1 " 2½
1½	205	.020 " .035	4 " 7	160	.015 " .020	2½ " 3	80 " 120	.012 " .020	1 " 2½
2	190	.020 " .035	4 " 7	150	.015 " .020	2½ " 3	75 " 114	.012 " .020	1 " 2½
2½	180	.020 to .040	3½ to 7	140	.020 to .030	2½ to 4	70 to 108	.012 to .020	¾ to 2
2½	170	.020 " .040	3½ " 7	130	.020 " .030	2½ " 4	65 " 102	.012 " .020	¾ " 2
2½	165	.020 " .040	3½ " 6½	120	.020 " .030	2½ " 3½	60 " 95	.012 " .020	¾ " 2
2½	155	.020 " .040	3 " 6	115	.020 " .030	2½ " 3½	60 " 90	.012 " .020	¾ " 1½
2½	145	.020 " .040	3 " 6	110	.020 " .030	2½ " 3½	55 " 85	.012 " .020	¾ " 1½
2½	140	.020 " .040	2½ " 5½	108	.020 " .030	2 " 3½	55 " 80	.012 " .020	¾ " 1½
2½	130	.020 " .040	2½ " 5	104	.020 " .030	2 " 3	52 " 77	.012 " .020	¾ " 1½
3	125	.020 " .040	2½ " 5	100	.020 " .030	2 " 3	50 " 75	.012 " .020	¾ " 1½

of the pin serves to increase the grip of the lever. This method has proved such a success that the principle is being applied to several other jobs of a similar nature.—American Machinist.

WORM GEAR CUTTING.

In a large Canadian plant where the class of machinery manufactured requires many worm gears, a different method of production than that in common vogue is made use of.

The customary method of cutting worm gears, is to attach to a dividing head in a milling machine, and make the first cut with an approximately shaped milling cutter, and afterwards allow a hob to run loosely in the roughed blank, producing a finished gear in two operations.

The accompanying sketch shows the simple device used by this firm. A is bolted to the milling machine table, the base fitting one of the grooves in the table. Through the centre of this stand A, passes a mandrel B, on which the gear blank is placed. On the other end of this shaft or mandrel B, is a worm gear C, meshing into a worm D, on a crosswise shaft, on the end of which is a chain gear E. This chain gear is driven from another chain gear on the milling machine spindle, secured on the spindle with the hob. The combinations of gears, worms, etc., is so arranged that through the train, the gear blank is made to revolve at just the proper speed for the hob.

The casting F is bolted to A, and is so arranged as to permit of vertical displacement, making possible various combinations of worms and gears at D and

worm gear can be cut, absolutely true, for the only chance for error lies in the chain, which gives no trouble as the strain on it is practically nil. This method is used exclusively by the company before mentioned, and gives most satisfactory results.

CALIPERING A FLANGE CASTING.

By K. Campbell.

One of the simplest ways of calipering over the flange of a casting is shown in the accompanying illustration. The calipers are set at an even distance on

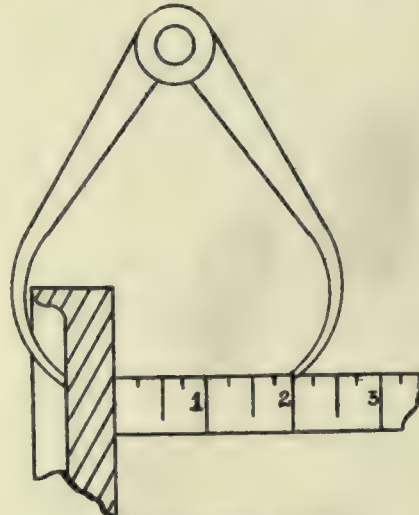

Calipering Flange Casting.

the rule, sufficient to allow the calipers to pass over the flange. In the illustration, the rule is set at two.

After carefully adjusting the calipers to 2 inches, remove the calipers over the flange and measure the opening of

JAW FOR GRIPPING WOOD.

Reference to Fig. 1 shows a peculiarly outlined surface, intended for the gripping face of a wood clutch in a wood-working machine. First impressions would seem to convey the difficulty of producing such a surface, while in reality the operation is very simple, the finishing and grooving as shown being

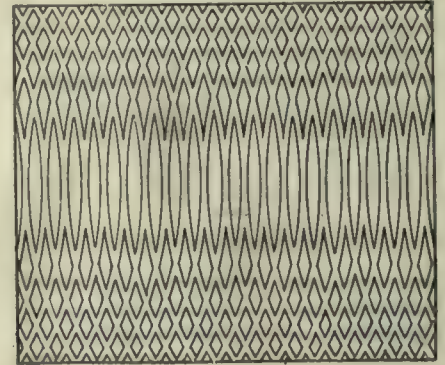

Fig. 1.—Wood Grips.

all done in one operation. The surface is covered with grooves about 1-16 in. wide by 1-32-inch deep, making a good gripping surface for the wood.

As already mentioned, the operation is simple, it being all done in a vertical miller, using an inserted tooth cutter with 16 blades and 1-6 in. feed. One of these inserted teeth is ground as shown in Fig. 2, the projection cutting the groove in the face of the plate. The outer edge of the grooving tooth, and all the other teeth do the plain finishing of the surface, while back from these cutting edges, once every revolution, a circular groove is cut every 1-6 inches, determined by the pitch. By continuing the cut across the face, so that the other side of the miller comes into the surface, the grooves in the other direc-

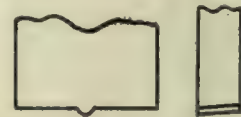
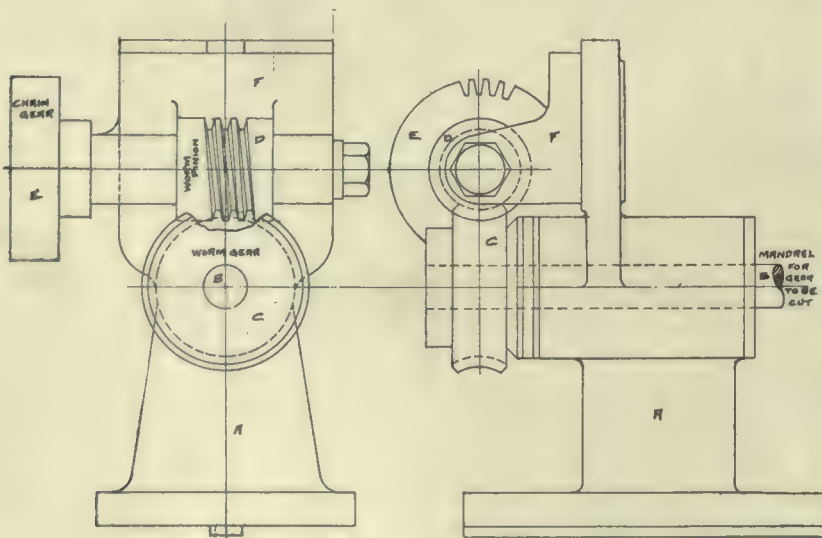

Fig. 2.—Wood Grips.

tion are formed. In order that these grooves match at the centres, as shown in Fig. 1, the projection as in Fig. 2 must be at a radius that will give a diameter in even inches or even sixths of an inch. In this case, it is an even 5 inch diameter.

This process gives a good grip at low cost, as the plain operation of machining takes nearly as long as the completed job, the two being simultaneously done, with the exception of the last little while that the back part of the cutter is merely grooving.



Worm Gear Cutting.

C, respectively, as well as different chain gear changes at E and on the spindle. By these changes, and having a suitable stock of gears, worms, etc., almost any

the calipers. By subtracting 2 from the second measurement, the actual thickness of the web of the casting is given.

CANADIAN MACHINERY

AND MANUFACTURING NEWS

A monthly newspaper devoted to machinery and manufacturing interests mechanical and electrical trades, the foundry, technical progress, construction and improvement, and to all users of power developed from steam, gas, electricity, compressed air and water in Canada.

The MacLean Publishing Co., Limited

JOHN BAYNE MACLEAN, President W. L. EDMONDS, Vice-President
 H. V. TYRRELL, Toronto Business Manager
 G. C. KEITH, M.E., B.Sc., Toronto Managing Editor
 F. C. D. WILKES, B.Sc., Montreal Associate Editor

OFFICES:

CANADA
 MONTREAL Rooms 701-702 Eastern Townships Bank Bldg
 TORONTO 143-149 University Ave. Phone Main 7324
 WINNIPEG, 511 Union Bank Building Phone 3796
 F. R. Munro
 BRITISH COLUMBIA - Vancouver Room 21, Hartney Chambers
 H. Hodgson
GREAT BRITAIN
 LONDON - 88 Fleet Street, E.C. Phone Central 12960
 E. J. Dodd

UNITED STATES
 NEW YORK - - R. B. Huestis
 1109-1111 Lawyers' Title, Insurance and Trust Building
 Phone, 1111 Cortlandt

FRANCE
 PARIS John F. Jones & Co.,
 31bis, Faubourg Montmartre, Paris, France

SWITZERLAND
 ZURICH - - Louis Woll
 Orell Fussli & Co.

Cable Address:

Macpubco, Toronto. Atabek, London, Eng.

SUBSCRIPTION RATE.

Canada, United States, \$1.00, Great Britain, Australia and other colonies 4s. 6d., per year; other countries, \$1.50. Advertising rates on request.

Subscribers who are not receiving their paper regularly will confer a favor on us by letting us know. We should be notified at once of any change in address, giving both old and new.

Vol. VI.

September, 1910

No. 9

A CRY FOR BUSINESS MEN.

The National Council of Industrial Defence of the United States are dissatisfied with the legislators at Washington. They say there is not enough practical business men among them and venture the opinion that "every thinking man who reads" must recognize that they are constantly building into the laws of the United States "restrictions that bind the hands of our manufacturers and control the decisions of our courts on questions involving the relations of capital and labor."

Our experience in Canada is not of such an extreme type. Justice is administered with equity. One reason for this may be that our judges are not dependent upon the whims of a fickle electorate for continuance in office. Prejudices may at times influence them, but ulterior motives is not one of the sins that can be laid at their door.

But when it comes to a need of more business men among those who make our laws, the conditions are much the same in this country as in the United States.

Such business men's organizations as the Canadian Manufacturers' Association find it necessary to watch very carefully when the Federal and Provincial Parliaments are in session that no legislation inimical to their interests is allowed to slip through. All this costs money.

Sir Wilfrid Laurier, the Premier, and Mr. R. L. Borden, the leader of the Opposition, have both expressed a desire to see more practical business men in the House of Commons. It is not, therefore, business men themselves alone that recognize the need.

Possibly some time in the future there will be found more successful business men who will be self-sacrificing

enough to give a due portion of their time and attention to the affairs of the state. Until then it is futile to look for much improvement in the businesslike qualities of our legislators.

SAVING HEAT UNITS.

The saving of a little hot water which formerly went to waste resulting in the saving of thousands of dollars should make superintendents and manufacturers think carefully of what the attention to seemingly minor things, means. Allowing the hot drips from a heating system to run into the drain looks like a small thing, but is it?

If a plant is located on a water front try throwing a bushel of coal into the water each day. Figure what the waste will mean in a year. You will then have an idea of the fuel that is being thrown away by hot drips being fed into the sewer. Mr. Peiler's paper in this issue gives a clear idea of what saving of waste means and it should be perused with a great deal of interest.

MAN'S HUMANITY TO MAN.

It was with pleasure that Canadian Machinery read the following announcement showing the interest of one large corporation in its men:

J. R. Booth, two thousand of whose employes were out of work for several days, owing to the closing of his big lumber mill, through the strike, has announced that every man will be paid for his lost time. A deputation of employes waited on him at one o'clock this afternoon to thank Mr. Booth, and the veteran lumberman was cheered by the entire mill staff.

TO INCREASE OUTPUT WITHOUT ENLARGING.

Sometime, perhaps, in the history comes to the manager the question of increased production. Ways and means are considered and it is often decided that the only way possible is to enlarge the plant. The next step is to secure the necessary capital. To take it from the working capital is to cripple the productive end of the business.

If foremen, superintendents or managers will look carefully over their plant they will possibly find a way of increasing production with the investment of very small capital, as other companies have done. Machinery has greatly improved, and by a few changes old machines can be made to use high-speed steel and thus increase the output.

Another way is to increase the efficiency of the men. This can be done by installing a bonus or premium system. The men make higher wages and both men and company benefit by the arrangement.

In a boiler works in Ontario, about a year ago there was little work, and a number of men were laid off. The best mechanics were kept on, though there was not much for them to do. They got into the habit of doing little and manufacturing costs went up to a high figure. Then business became brighter, men were taken on, but the costs continued to soar. After a thorough examination by the cost clerk, it was found that the men were working at a very low speed. On his recommendation boilers were manufactured for stock, putting the men on piece-work, and keeping them working at their former pace before business had been slack. This increasing the efficiency of the men had the expected result of lowering the costs to their normal amount.

There are few works in which there is not waste space. A manager looking carefully over his plant can discover

this. Then, by a little re-arranging of the machinery in the shops additional space is available.

Jigs and templates assist in the rapidity and accuracy of production. Where there are a number of duplicate parts, a carefully made jig or template will ensure rapid machining, such as drilling, etc., and if the jigs and templates are taken care of they will last for many years.

A great number of other points could be brought to the attention of the manager, such as installing new machines with greater capacity, replacing heavy cast iron with wood split pulleys, studying the question of bearings, etc. All these changes may be made without spending a cent for new buildings. There are probably many other things about a plant which will only be revealed by a critical examination. In this way the capacity of a plant may be increased from ten to forty per cent., some changes giving a greater increase of production than others.

Of course, we do not mean to say that new buildings should not be erected, nor should additions be made. We have only tried to point out how increased production may be obtained with a small investment, when the necessary capital for a new plant is not available.

THE TECHNICAL PRESS AND TECHNICAL EDUCATION.

At the present time, when the matter of technical education is one of the subjects uppermost in the minds of many, it seems an excellent opportunity to draw attention to the wonderful assistance the technical press has afforded technical education in bringing it to its present developed state.

The commission appointed by the Government has been looking into the educational matter, and on their trip so far through the Maritime Provinces, have accumulated much information, reports of which appear in the daily press. Canadian Machinery has endeavored to keep abreast of this want for further knowledge along these lines, as is instanced by a description of one of the most progressive schools in the United States—the Cleveland Technical School—given in the August number; and in this issue appears an article on the technical course at the Manitoba Agricultural College.

Coming to the point of relationship between technical education and the technical press, a very little consideration will show that the latter has been probably the most potent factor in the agitation that is being felt all over the world—for more complete education for the working man, along the lines of his daily work, rather than going to the opposite extreme of educating with the professional idea in view as has been customary till quite recently.

The technical paper in its present form is a comparatively recent innovation. Its scope is very wide, reaching representative men in every trade. As most of the articles given are not gotten up on the spur of the moment, as with the daily paper, the element of error liable to enter is eliminated to a great extent, with the result that the technical paper has gained a reputation for veracity and reliability, built up largely by the fact that most of the articles are written by experts in their line. Thus, a power has been created. Information obtained as it has been, at regular intervals, has created a desire for more complete knowledge. This is stimulated by the appearance from time to time of articles containing more than the usual amount of mathematical theory, develop-

ed to deduce some practical result. The mechanic, reading this, feels his lack of education along this line, and out goes the cry for assistance—for lessons in fundamental engineering. Some papers have attempted to meet this demand themselves, with varying degrees of success, for the majority of papers have new subscribers adding to their number constantly, so that anything like consecutive work is difficult to obtain. Still further have these attempts stimulated the desire. This is witnessed in the United States, the Mecca for technical papers, where the agitation for more technical education has been very strong, resulting in the foundation of many such schools—the Cleveland school affording an example.

From this it can be seen that the technical press has been creating this desire—unwittingly to a large extent—and this desire fortunately has taken, and is taking, action, as witnessed by the constant agitation for it in the daily press.

LIGHTING THE MACHINE SHOP.

That men should have light to work with on dark days is conceded. But why give him a candle, if for a few cents more you can save his eyesight, add to his comfort, make him more efficient, and save money on the running cost of the light?

When one considers the number of working hours in which production is dependent either wholly or in part on artificial light, it is surprising that more superintendents and manufacturers of industrial plants do not take proper interest in the subject of illumination, and the higher standard of lighting installed in some workshops.

If a workman has poor tools, poor work is a direct sequence; therefore, give him proper light with which to work. By taking care of the employes, their productive efficiency is increased. Man dislikes a gloomy room. On the other hand, he likes the cheerful effect of the brightly-lighted shop, and proprietors, superintendents and managers would do well to investigate the modern scientific system of illumination.

A GROWING REVENUE.

For the first four months of the present fiscal year Canada's revenue shows an increase of \$5,625,148 over the corresponding period of last year. For the same period the expenditure on revenue account increased by \$1,258,651, while the capital expenditure decreased by \$631,884, leaving a net betterment of over five millions.

For the four months the total revenue has been \$35,655,439, the customs receipts totaling \$23,005,748, or \$5,087,918 better than last year. The expenditure on the consolidated fund account has been \$22,044,077, and on capital account \$5,797,337. The excess of receipts over the total expenditure has been \$7,804,025. Indications point to a surplus this year of revenue over all ordinary expenditure even larger than last year's record surplus of \$22,000,000. For the month of July the revenue totalled \$9,320,586, an increase of \$883,148 over July of last year. Expenditure on consolidated fund account increased by \$1,242,290, and on capital account by \$232,380.

The net public debt of the Dominion at the end of the month was \$328,615,687.

POWER GENERATION ^A_N^D APPLICATION

For Manufacturers. Cost and Efficiency Articles Rather Than Technical.
Steam Power Plants ; Hydro Electric Development ; Producer Gas, Etc.

BELT LACING

By James E. Noble.

Wire lacing for belts is extremely good, as it has numerous advantages over other types, viz., elasticity, belt can be laced quickly, practically noiseless operation, and small cost, for considering everything, it costs less than most lacings.

In lacing with wire it is a good idea to insure the ends of the wire being

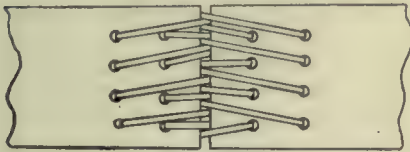

A Good Joint for Small Belts on small Pulleys at High Speeds, but All Right Anywhere.

forced into the belt, as otherwise a cut hand might result should an attempt be made to shift the belt by hand.

The ordinary rawhide lace is also good. A favorite method of lacing with rawhide is the hinge-joint; for joints of this nature have been known to run for several years without trouble. Another wrinkle, when putting up new belts, is to have a short intervening piece at the joint. After a few days operation, the belt will have attained such a slackness that the piece may be removed, and the belt will be then found to be at the correct tension.

It is said that a tension of 35 pounds per inch, exclusive of load, is quite sufficient to prevent belt slipping or creeping as it is sometimes called. A belt might run with practically no slip with a light load, and yet slip considerably with a heavy one, if the tension were not correct.

Much belt trouble is occasioned by the use of pulleys too narrow for their belts. In many cases, the pulley is exactly the same width as the belt. This should not be; the pulley should be wider than the belt whenever possible.

More caution should be exercised in the use of many of the so-called "belt dressings," which are often home-made mixtures of castor-oil and resin or some such combination. No matter how slack, dirty, greasy, wet, etc., a belt may be, use dope, appears to be the watch-word of most engineers. If the belt is large enough, and hugs the pulley closely, there should be very little slip. A simply experiment shows this. Wash and dry your hands thoroughly, and slide them along a smooth

polished surface, such as glass, and it will be noticed that the drag is considerable. A belt behaves similarly. If it is clean and large enough to carry the load, and if the tension is correct, no belt dope should be required. Of course, a little belt dressing to keep the belt soft and pliable, is essential, but it should be a dressing made by a reliable firm.

REPAIRING BOILER TUBES.

In the method of repairing boiler tubes, as done at the C.P.R. shops, West Toronto, there are several features of particular interest, which are worthy of note.

In old boilers, the tube ends sometimes become so rusted and corroded, that they must be removed, the ends cut off, and new ones welded on. As a large number of tubes require this treatment, several labor-saving devices have been improvised at the shops with the object of reducing expense, and at the same time improving the quality of the work.

In many shops where new ends are welded on, it is quite customary to merely expand the end, introduce the new piece, and weld in that position, without tapering the ends to fit each

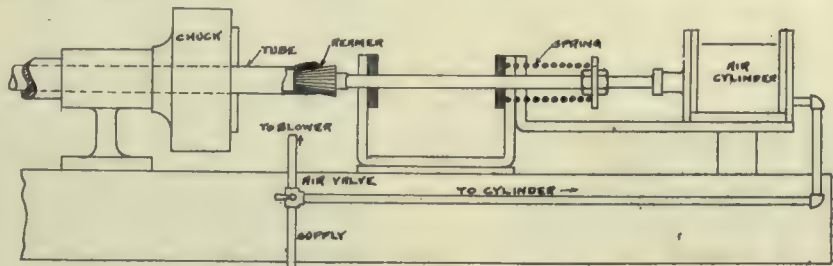

Fig. 1.—Repairing Boiler Tubes.

other. This method, owing to the sharp ends coming on the flat of the other part of the tube, always leaves a seam around the tube, which tends to weaken it, often producing fracture. The C.P.R. always ream out the end of the tube with a taper reamer to a sharp edge at the end, and the new end is tapered down similarly to fit in.

In reaming out the ends, an improvised machine, Fig. 1, is used, unique in some respects. Essentially it is a lathe, the original idea being the feed, which consists of an air cylinder which shoves forward the reamer. Air is controlled by a two-way valve, which allows air out another passage as desired to a piece of rubber hose, used to blow the chips away. When the cylinder is

released, the piston resumes its initial position again by the spring expanding. The make-shift construction of the lathe is interesting. It is formed of 2-7"x7" scantlings, on which are attached several wrought iron straps for securing the cylinder, etc. The reamer

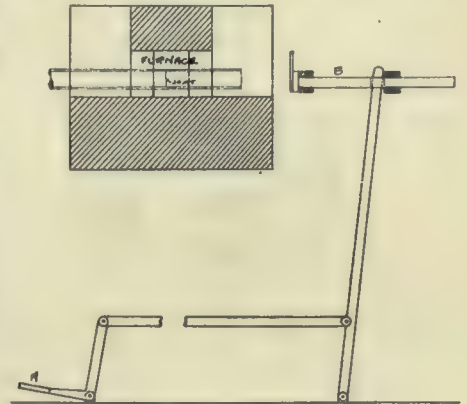

Fig. 2.—Repairing Boiler Tubes.

has a square shank which works in square holes in the cross-sectioned cross-pieces, which prevent it turning. The tubes are rapidly reamed by this method, a greater pressure being given than if fed by hand.

When ready to be welded, the two

parts are placed together, and shoved into a furnace as in Fig. 2. The heat has a tendency to loosen the pieces which were lightly placed together, so,

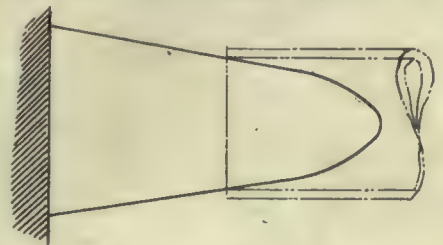

Fig. 3.—Repairing Boiler Tubes.

if removed when heated without precautions, they would probably part. A single expedient prevents this. When ready to remove, a tread A, some 4 or

5 feet back from the furnace, is pressed which slides bar B in its guides, the plate on the end striking the short piece of tube sharply, driving it further into the tube to be repaired, for the pieces are soft from the intense heat. This act in itself practically welds the pieces together, as well as doing what was originally intended, i.e. preventing the pieces falling apart before welding.

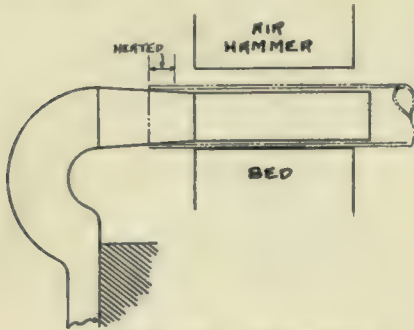

Fig. 4.—Repairing Boiler Tubes.

The welding is done under a quick-acting air hammer, the tube being slipped over a mandrel during the operation. The process insures a very nearly perfect joint, without mark, the size of the pipe being but slightly below the standard.

Before putting into the boiler the back end must be expanded slightly so as to fit the tube sheet better. Formerly, this was done as in Fig. 3, by first heating the end of the tube for about an inch, and driving the tube up on a tapered pin, by a couple of men swinging back and forth onto the pin, driving it further each swing till expanded the proper amount, a very slow job.

Fig. 4 shows the method used now for expanding the end. As before, the end is heated, but with the difference that it is now placed on a mandrel, tapered at one end, and under an air hammer. The oscillations set up in the pipe by the quick acting hammer striking the cold part, back from the heat, causes the end to swell, the operation being practically instantaneous, the blows being so rapid. The method is very much quicker and better than the old way, and the production is greatly increased.

DISINFECTION OF RAILWAY CARS.

The running of a railroad in Germany is evidently accompanied with unpleasantness, if one may judge from the accompanying photograph. The Potsdam shops, which are responsible for the proper maintenance of rolling stock, have been confronted with the difficult task of disinfecting the cars. It seems that the coaches which return from Russia are literally a-swarm with vermin. Even

after the cars had been cleaned with true Teutonic thoroughness, there was still the possibility that living disease germs might lurk in the walls and hangings. It was therefore the practice for some years to take down all the upholstery, curtains, etc., and to clean everything thoroughly. Naturally, the expense involved was heavy, and the cars were withheld from service for a considerable time. Moreover, there was also the danger of infesting the shops and other cars.

The problem seems to have been successfully solved by Julius Pintsch, who applied to the railway car a principle of disinfection which has been successfully employed on vessels. His disinfecting apparatus consists of an iron cylinder built up of cast iron annular sections, of 16 feet internal diameter. The inside length is about 72 feet. The cylinder is so stoutly constructed that it can easily support without deformation a 30-ton car.

During disinfection the air within the cylinder is considerably rarefied by a pump, and as a result the outer air exercises a pressure of about 1,900 tons on the disinfecting cylinder. Since the apparatus is heated during disinfection, allowance has to be made for expansion.

It is employed to make the closure hermetic. Huge bolts hold the closure, gasket and cylinder together. Steam is blown into the interior of the cylinder. Two hundred and fifty steam pipes line the interior of the cylinder, all receiving their supply from the main pipe. The total length of all these pipes is about 1½ miles. In order to heat the air within the cylinder quickly and uniformly, two blowers are set in motion, so that all the air is brought in contact with the heating tubes. Even during the coldest weather the temperature within the cylinder can be raised to 140 deg. F., in from one to two hours. In order to heat an entire coach to this temperature, about five hours is required. After the car has reached the proper temperature, the air is pumped out of the cylinder until a vacuum of 70 to 74 centimeters of mercury under the normal pressure is obtained. At this atmospheric pressure water will boil at 104 deg. F. Hence all moisture is evaporated from the car without injuring the parts by the excessive heat. In no other way is it possible to kill vermin effectually. The upholstery, curtains, hangings, etc., are not in the least injured.

For very special purposes the cars may be disinfected with formaldehyde

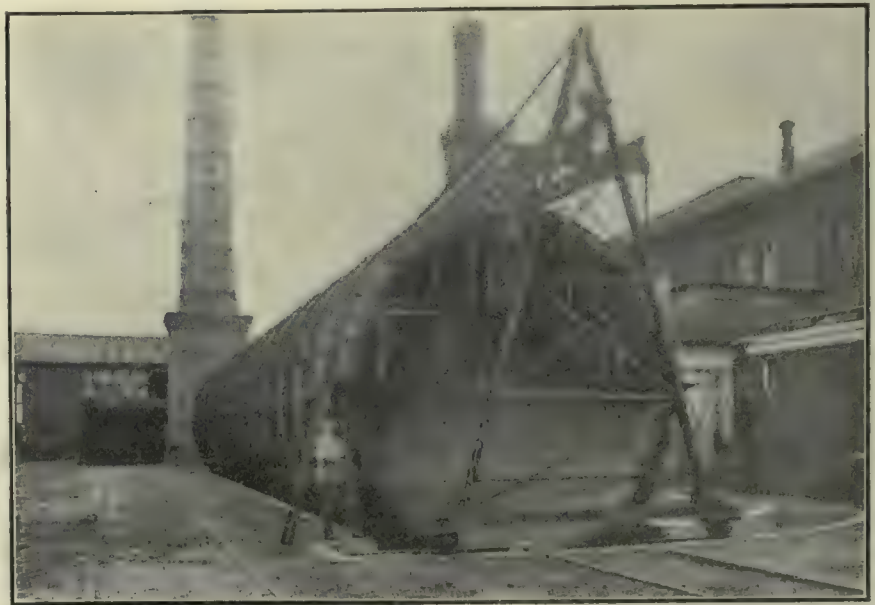

Sealing Cylinder With Two-ton Gasketed Closure Before Exhausting Air and Turning on Steam to Disinfect Car.

Hence the cylinder is mounted upon rollers, so that the apparatus can yield to an extent of about three-quarters of an inch in length, which is the amount of expansion.

Before it is run into the cylinder, all the windows and transoms of the car are opened. By means of a crane a two-ton closure is brought against the open end of the cylinder. A rubber gas-

gas. At the very first attempt, a car was thoroughly purged of vermin. To make assurance doubly sure, and to test the efficacy of this formaldehyde disinfecting method, a glass vessel full of the living insects had been purchased from a professional vermin-exterminator in Berlin. This vessel was placed in the car and covered with cotton and linen. The insects were all killed.

DEVELOPMENTS IN MACHINERY

New Machinery for Machine Shop, Foundry, Pattern Shop, Planing Mill; New Engines, Boilers, Electrical Machinery, Transmission Devices.

CINCINNATI CONE DRIVEN MILLER.

Some of the milling work in every shop is light and can therefore be done on a modern cone driven miller as fast and as accurately as on the more highly developed single pulley type of machine. It follows therefore, that the cone driven machine is the most economical one to use on such work.

There is of course a recognized field for the heavy and powerful single pulley type of machine, but this does not in any way restrict the field of usefulness of the cone driven machine.

That these facts are thoroughly appreciated by the Cincinnati Milling Machine Co. is evidenced by their having redesigned their entire line of cone driven millers. The illustrations herewith show the more important improvements that have been made. The column is very similar to the column used on their line of high power machines. It is a symmetrical box section, having straight lines and large enough to contain the entire feed drive mechanism.

The feed changes are all obtained from a single group of mechanism which is

mounted in the column at a point high above the floor, bringing all the levers within easy reach, and the index in plain sight, of the operator.

The inside of this mechanism is shown in Fig. 2. It is a single unit,

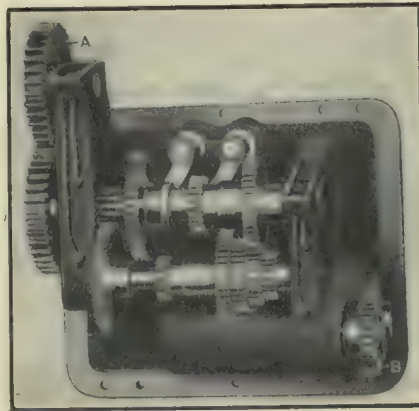

Fig. 2.—Feed Change Mechanism.

assembled complete by men who are specialists on this work and when placed in the column, it becomes an integral part of the machine. It provides 16 changes of feeds, from .007 to .300 per

revolution of cutter, and all these changes are obtained by means of the 12 gears shown between the two housings in Fig. 2.

The keynote of the entire design is simplicity coupled with handiness in operation. The drive is direct from the face gear which meshes with gear A. Power is transmitted through the change gears to the gear "B" which drives the universal joint shaft.

The outside of the box, showing the lever arrangements and the feed index, are shown in Fig. 3. All of the sixteen feed changes are obtained by the three levers shown. The position is clearly indicated by letters and figures. The feed index, mounted immediately above the levers, is of the same simple form that is used by this company on their line of high power machines. There is no chance for confusion, because the exact lever positions are plainly given below the figures representing each one of the feed rates, and all that is left for the operator to do is to move the levers to these positions.

The most striking feature of this design is the tumbler construction. This tumbler is made in the form of a cylinder of large diameter which supports the tumbler shaft and gear, and is itself supported in the frame of the feed box. This construction obviates all bending of the tumbler shaft, as well as all vibration in the tumbler.



Fig. 3.—Outside of Feed Box.

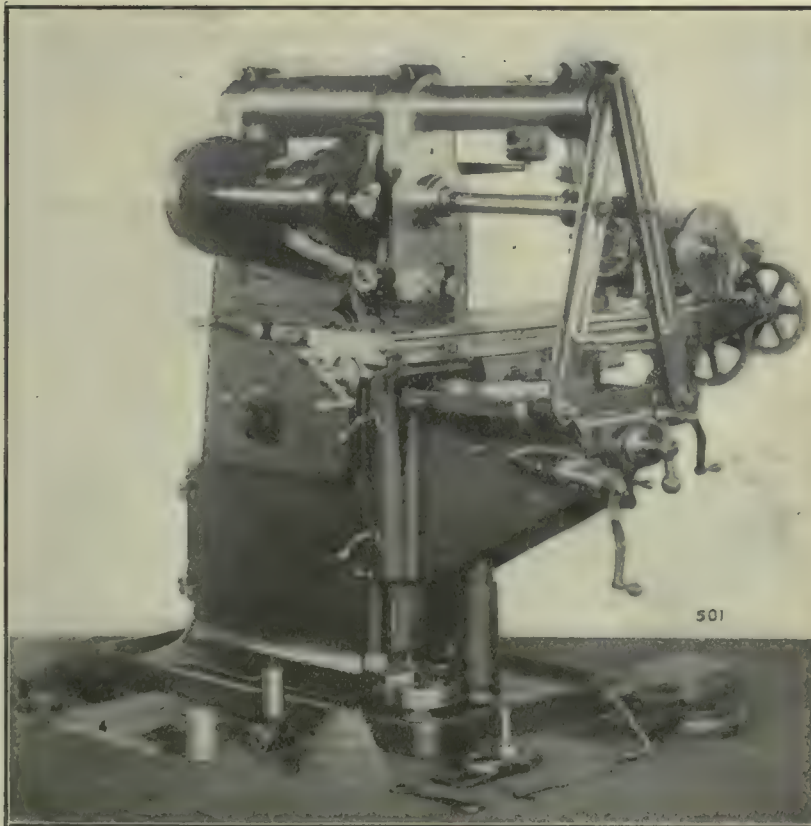

Fig. 1.—Cincinnati Cone Driven Miller.

The tumbler operating lever projects through a hole in the feed box in the usual way, but this opening is completely closed at all times by the tumbler, thus thoroughly protecting the inside mechanism from dust.

The cone driven miller is manufactured by the Cincinnati Milling Machine Co., Cincinnati.

MOTOR DRIVEN DRY GRINDER.

The accompanying picture shows an example of the extreme simplicity very often obtainable with direct motor driven machines. While the equipment possesses all the advantages inherent with the use of electricity in this class of service, its most striking features are its space economy and that it is entirely self-contained.

The equipment, with the exception of the motor, is made by the Springfield

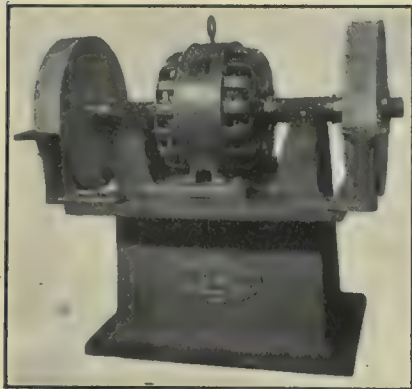

Motor Driven Dry Grinder.

Mfg. Co., Bridgeport, Conn., and is known as their "Type D-M Dry Grinder." The wheels are 24 inches in diameter by 4-inch faces and are driven by a Westinghouse CCL induction motor. The motor shaft is special, being extended at each end to carry a grinding wheel. The regular motor bearings are omitted and the shaft turns in special self-oiling bearings two inches in diameter by eight inches long. The supports for these bearings are cast solid with the grinder base.

STATIONARY DIE HEAD FOR PIPE THREADING.

The illustrations given herewith show a stationary die head for pipe threading as manufactured by the Landis Machine Co., Waynesboro, Pa., using the Landis type of die with a manually operated die head.

This head is made especially for use on pipe threading machines wherein the pipe revolves and the head remains stationary, the dies being opened and closed by hand. The head is made entirely of steel as are also the die holders. The head can be mounted on the carriage of any of the standard pipe machines and can be handled in the same manner as the other styles of heads, but has the advantage of the long life die as illustrated herewith.

The chaser for these die heads can be made to good advantage from high speed steel, as they never require to be

annealed, rehooped or retempered, and their life is much greater than that of the usual type. The sharpening of the die is taken care of by grinding on the ends of the chasers and again setting them to the correct cutting position in the holders by means of a small gauge furnished with your die head.

The heads are made in standard sizes to take work up to and including 4 in. One of the great advantages in this die for threading pipe is the fact that one set of dies will cut all the diameters coming within the same pitch. As there is but one pitch covering the sizes from 1-inch to 2-inch inclusive one set of dies covers this range. The same is true on the other pitches.

The small cut shows one of the holders used on pipe for threading where it is not necessary to cut very close to a shoulder. The clamp with which this chaser is held is what is known as their mill clamp, which besides holding the chaser rigidly protects the chaser in case the pipe splits which very frequently happens. The clamp as shown in the cut comes down over the throat of the die and is rounded out near the cutting point so as to act as a guide for rough ends, and at the same time protecting the die in such manner that the liability to breakage is very small. In cases of threading close to a shoulder, a clamp is used which comes flush with the front edge of the chaser only, thus permitting the die to run close up against the shoulder as in threading short nipples, etc.

This new type of die admits of greater cutting speeds than the hobbed type and the rake can at all times be ground to suit the quality of the material in the pipe to be threaded.

The heads are graduated for setting the dies to the different diameters to be threaded. The head is opened and closed by hand and when in the closed position the die is rigidly locked, but opens and closes freely by means of the lever.

The advantages in this head lie in the life of the dies; the higher cutting speeds that can be obtained, and the flexibility of the die to the different qualities of material to be threaded.



Holder for the Stationary Die Head.

All dies are made interchangeable and if one chaser of a set should be worn out in advance of the others this single chaser can be replaced without replacing the entire set. Dies of any one pitch will interchange on any of the die heads so long as the pitch is within the range of the head.

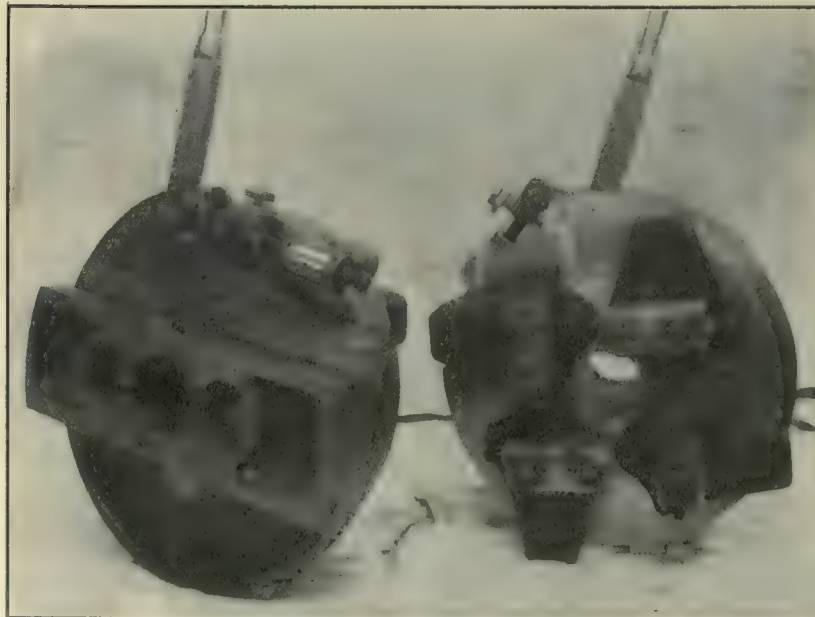

Stationary Die Head for Pipe Threading.

FOUNDRIY PRACTICE AND EQUIPMENT

Practical Articles for Canadian Foundrymen and Pattern Makers, and
News of Foundrymen's and Allied Associations. Contributions Invited.

PIPE PATTERN.

By F. S. C.

As a practical knowledge of molding is necessary to enable a patternmaker to intelligently make patterns, I am giving my reasons for stating that patterns are best made as here described.

Pipe patterns from the small gas pipe fitting to the largest iron sewer or drain pipe, are, perhaps, the most common patterns required of the patternmaker.

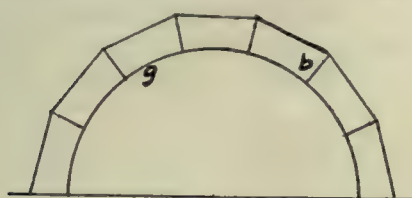

Fig. 1 a.—Pipe Patterns.

An enumeration or description of all the ways by which different pipes can be made would take too much space, so will be dispensed with in this article.

The small gas pipe fittings have been made in past years from gated brass patterns on follow boards and molding machines using cores made in multiple core boxes, where required. The more modern way of making these or any other small or moderate-sized castings in quantities, is by means of iron molds. These molds are like large core boxes, made to suit the shape of the outside of the casting required, and are hinged and locked with a convenient and rapid-locking attachment. These molds must be of sufficient thickness of iron (not less than 3 inches) to prevent it becoming hot and sticking to the casting while being



Fig. 1 b.—Pipe Patterns.

made. The gate is made to run down the parting so that when the mold is open the gate and casting required will drop out. Castings made in these molds are not chilled, because the molds are heated before receiving the iron, and the casting is dumped out before it becomes chilled, as iron does not chill until after it has become a solid casting.

In making patterns for what we might term the common sizes of pipes, that is, from 6-in. to 30-in. drain, there are a few

kinks worthy of notice. When building up a pattern with staves, as shown in Fig. 1 (a), if it is not possible to saw them with the circular saw, to the correct

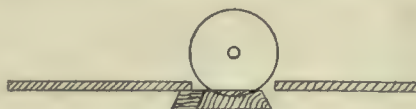

Fig. 1 h.—Pipe Patterns.

bevel necessary at b, a very convenient and rapid way is to bevel a piece of wood, as shown at c, Fig. 1, (b), and fasten the staves to it by means of pinch dogs, as shown at dd, when then can be conveniently planed off across the dotted line ef, and then reversed for the other edge. If the staves are required to be concaved at g to fit round heads or ends, a good way is to run them across the circular saw, as shown at h, Fig. 1, using a crosscut saw and having the saw guard set at an angle, as shown at i, Fig. 1.

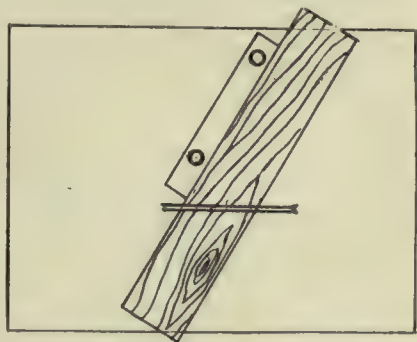

Fig. 1 i.—Pipe Patterns.

To make a strong and serviceable pipe pattern of approximately two feet diameter, it is best to make the heads of two layers of pine, crossing the grain, as shown at (a), Fig. 2. This prevents any chance of them warping out of the circular form. The flanges are best built up of two or three layers of segments and bound on the outside by 1/8-in. band iron. This prevents breakage if struck

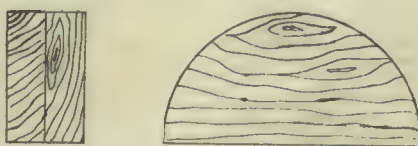

Fig. 2 a.—Pipe Patterns.

by the rammer in the foundry. The core print should be turned to leave a fillet at c, Fig. 2, which prevents the sand

breaking away when drawing the pattern, and also obviates any risk of crushing the sand into the mold when putting in the core.

A pattern for a pipe, as shown in Fig. 3, may be made in several different ways. When the diameter of the pipe is small enough to permit of being made solid without having the pattern too heavy, the branches may be joined to the main pipe if they are both of the same dia-

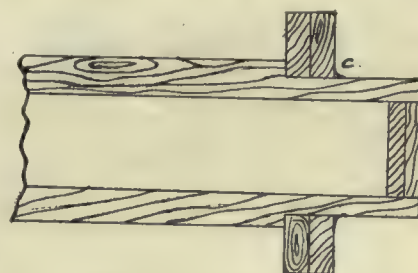

Fig. 2 b.—Pipe Patterns.

meter by sawing a piece out of the main pipe at an angle of 45 degrees, and making the branches to suit, as shown at e, Fig. 3; or, if the branch is smaller, it may be sawed by means of two pieces temporarily nailed on, as shown at d, Fig. 3, so that the branch may be hand-sawed to fit main pipe. First a piece of 1-in. stuff should be sawed to fit around branch pipe, as shown by lines between e, f, g, h, the distance from the

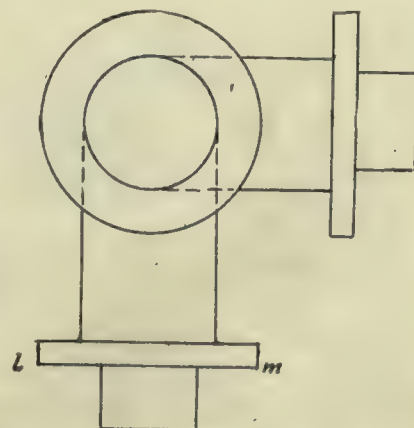

Fig. 3 a.—Pipe Patterns.

centre of pipe to the line gh being equal to the radius of the flange on other end of branch, as both will bear on the saw table when being sawed. The piece ij is sawn out, as shown at k to suit the diameter of the main pipe e, f, g, h, the lines. ij being made parallel with the line gh. These pieces being secured to

the branch, it can be sawn, using circle at k as a guide, and secured to main pipe without any further fitting.

The next point of interest is the lower branch part. The easiest way for the

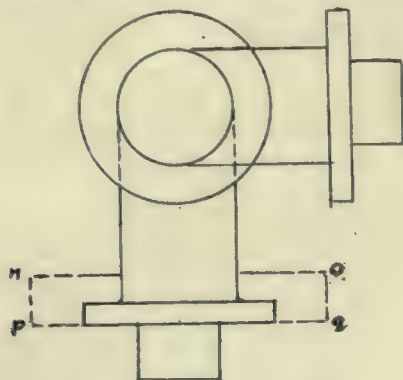

Fig. 3 b.—Pipe Patterns.

patternmaker would be to leave the flange lm loose over the core print, letting the core print act as a dowel to centre it. But when a number of castings

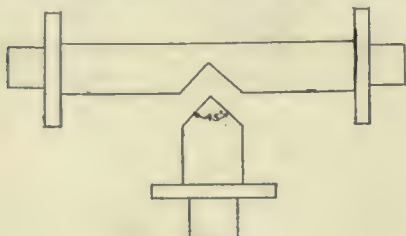

Fig. 3 c.—Pipe Patterns.

are required, the best way is to make a core box to produce a core the shape of the dotted lines between n, o, p, q. Fig. 3, (b), having the flange in, and fitting the pattern in centre, on the line no. This core is placed on the pattern, which

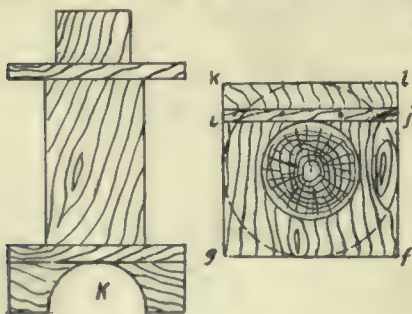

Fig. 3 d.—Pipe Patterns.

is made as if there was no flange required on it, and the green sand is rammed around, holding core in place and permitting pattern to draw as if it were a straight piece.

A very successful picnic was held a short time ago when the Gartshore-Thomson Pipe & Foundry Co., Hamilton, went to Niagara Falls, taking about 700 pleasure seekers. A tired but happy crowd arrived home that night after a most enjoyable day.

CHEMICAL STANDARDS FOR IRON CASTINGS.

By John Jermain Porter.

Cast iron is a complex alloy of six or more elements. The common elements are: Iron, carbon, silicon, sulphur, phosphorus, manganese; and the other elements sometimes present are: copper, nickel, oxygen, nitrogen, aluminum, titanium and vanadium.

Iron occurs in three allotropic forms known as alpha, beta and gamma, whose properties differ greatly. Absolutely pure iron is unsuitable for castings.

Carbon is the most important element in cast iron. It exists in many forms, all of which are included under the two heads of graphite and combined carbon.

There is still much doubt about the iron-carbon diagram. Upton's construction is the most recent, and probably nearest the truth. This diagram holds only for very slow cooling, but gives us a consistent basis of reasoning.

The total carbon is dependent upon the temperature in the blast furnace, the conditions of melting and the percentage of other metalloids.

Graphite weakens iron. The amount depends upon the per cent. of total carbon, the rate of cooling, the per cent. of silicon, the per cent. of sulphur, and the per cent. of manganese. The normal graphite limits are shown by equations.

Combined carbon hardens iron and may increase or decrease the strength. The amount depends upon the per cent. silicon, the rate of cooling, the per cent. sulphur and the per cent. manganese.

The approximate effects of carbon are shown diagrammatically.

Silicon exists in cast iron in the form of silicides. Its chief effects are through its action on the carbon.

Increasing the silicon decreases the total carbon because it replaces carbon in the molten solution.

Increasing the silicon increases the graphite because it replaces carbon in the solid solution, the displaced carbon being preprecipitated as graphite.

Iron-carbon diagrams for commercial cast irons containing 1, 2 and 3 p.c. silicon are given and explained. The theory of malleableizing and of Custer's process are explained by these diagrams.

Phosphorus exists in cast iron as the phosphide Fe-3 P which is insoluble in the solid iron-carbon solution. It forms a ternary eutectic containing 2 p.c. carbon, 6.7 p.c. phosphorus, and 91.3 p.c. iron, which has a freezing point of 1740

deg. Fahr. Phosphorus decreases the total carbon and the relationship is shown by a diagram.

The net effect of 1 p.c. phosphorus is to lower the temperature at which freezing begins 50 deg. Fahr., lower the temperature at which freezing ends 425 deg. Fahr., increases the temperature range of solidification from 50 deg. to 375 deg. Fahr.

According to Upton, the effect of phosphorus on carbon is to slightly increase graphite and decrease total carbon.

Sulphur exists in cast iron as iron sulphide and manganese sulphide.

Iron sulphide forms a eutectic with iron melting at 1780 deg. Fahr. and insoluble in the solid iron-carbon solution. It therefore forms films between the iron crystals and causes brittleness.

Manganese sulphide does not form these films and is less detrimental. Manganese has a greater affinity than iron for sulphur and with enough manganese all the sulphur will be in combination with it.

Sulphur has a greater tendency to segregate than any other constituent of cast iron. This tendency is greatest with manganese sulphide.

Sulphur tends to decrease graphite and increase combined carbon. Upton's explanation of this is given.

The presence of silicon decreases the amount of sulphur which cast iron can take up. Much sulphur reduces the total carbon, and vice versa.

Manganese may exist in cast iron as manganese sulphide or as manganese carbide. According to Upton's theory, manganese carbide does not exist but the manganese is in the form of a solid solution. This theory does not seem satisfactory.

Manganese has little effect on the melting point or composition of the iron-carbon eutectic. It strongly retards the gamma to alpha transformation and thus tends to harden iron.

Manganese can neutralize sulphur and will also remove dissolved oxide at high temperatures as in the blast furnace.

Traces of copper are common in pig iron. Its effects on cast iron are poorly understood. In steel, copper increases fluidity, hardness, and tensile strength, and decreases ductility and ease of forging. Cast iron will take up only about 5 p.c. copper and this does not affect the casting properties. Copper accentuates the red-shortness due to sulphur through the formation of the ternary Fe-Cu-S eutectic. Copper prevents a complete evolution of sulphur in iron analysis.

Small amounts of nickel occur in many pig irons. Its chief effect is to lower the gamma-alpha transformation temperature and to increase the graph-

Acid Resisting Castings

Ref.	Silicon Per cent	Sulphur Per cent	Phos. Per cent	Mang. Per cent	Comb. Carb. Per cent	Total Carb. Per cent
7	1.00	.050	.50	3.00
42	2.30	low	.20	.41	3.60
81	.80-2.00	.02-.03	.40-.60	1.00-2.00	3.00-3.50
Sug.	1.00-2.00	und. .05	und. .40	1.00-1.50	3.00-3.50

Acid Stills and Eggs—See Acid Resisting Castings.

Agricultural Machinery, Ordinary

64	2.20-2.80	und. .085	und. .70	und. .70
	2.65	.050	.81	.70	.15	3.50
	2.25	.070	.70	.80	.30	3.50
	2.10	.068	.73	.45	.47	3.42
	2.00	.089	.89	.46	.50	3.39
Sug.	2.00-2.50	.06-.08	.60-.80	.60-.80

Agricultural Machinery, Very Thin

	2.90	.050	.85	.70	.10	3.50
	2.50	.080	.65	.60	.30	3.50
Sug.	2.25-2.75	.06-.08	.70-.90	.50-.70

Air Cylinders

64	1.20-1.50	und. .09	.35-.60	.50-.80
	1.90	.074	.50	.65
	1.12	.085	.40	.70	.70	3.50
	.95	.100	.30	.90	.80	3.40
	2.00	.070	.30	.60	.40
Sug.	1.00-1.75	und. .09	.30-.50	.70-.90	3.00-3.30

Ammonia Cylinders

14	1.20-1.90	und. .095	und. .70	.60-.80
Sug.	1.00-1.75	und. .09	.30-.50	.70-.90	3.00-3.30

Annealing Boxes, Pots and Pans

171	1.20	.060	.10	.40
81	1.80	.03	.70	.60	2.90
198	1.53	.04	.33	1.08	.58	3.68
Sug.	1.40-1.60	und. .06	und. .20	.60-1.00	low

Automobile Castings

	1.80	.030	.50	.70	.60	3.50
	1.65	.076	.45	.65	.55
	2.35	.072	.60	.70	.40
Sug.	1.75-2.25	und. .08	.40-.50	.60-.80

Automobile Cylinders

19	1.65	.076	.45	.65	.55
19	2.31	.094	.50	.43	.51	3.35
19	2.70	.053	.46	.23	.44	3.02
19	2.45	.102	.72	.41	.11	3.47
19	2.59	.083	.57	.47	.41	3.35
19	2.55	.104	.82	.32	.09	3.04
19	2.98	.047	.89	.27	.14	3.19
19	2.67	.111	.73	.38	.10	3.24
19	2.30	.084	.81	.52	.59	3.35
19	1.60	.083	.54	.42	.66	3.75
19	3.26	.159	.93	.44	.03	2.87
19	1.72	.091	.58	.48	.62	2.52
19	1.67	.068	.44	.82	.62	3.91
19	1.38	.093	.62	.52	.76	3.61
19	1.47	.075	.13	.60
19	1.50	.103	.86	.43
19	1.99	.130	.65	.39	.45	3.17
19	1.89	.090	.70	.39	.77	3.34
19	2.29	.090	.83	.60	.90	4.16
Sug.	1.75-2.00	und. .08	.40-.50	.60-.80	.55-.65	3.00-3.25

Automobile Fly-wheels

	2.35	.072	.60	.70	.40
	3.10	.045	.35	.55	.27
Sug.	2.25-2.50	und. .07	.40-.50	.50-.70

Balls for Ball Mills

196	1.00	.100	.30	.50	low
Sug.	1.00-1.25	und. .08	und. .20	.60-1.00	low

Bed Plates

	2.20	.090	.55	.50
	1.32	.090	.40	.60
	1.6528	.92	.72
	1.85	.080	.60	.55	.50	3.25-3.50
	1.80-2.20	.04-.06	.45-.55	.40-.50	.40-.50	3.40-3.60
	1.65-1.85	.070	.65-.80	.60-.75	3.85
Sug.	1.25-1.75	und. .10	.30-.50	.60-.80

Binders—See Agricultural Machinery

Boiler Castings

194	2.50	und. .07	und. .20	.80-1.0
	2.25	.060	.62	.59
Sug.	2.00-2.50	und. .06	und. .20	.60-1.0

Brake Shoes

95	1.50	low	low
64	2.00-2.50	und. .15	und. .70	und. .70
57	2.00-2.50	und. .15	und. .70	und. .70
	1.40-1.80	.06-.08	.50-.80	.45-.60	.40-.65	3.50
	1.86	.183	1.93	.33	1.22	3.01
Sug.	1.40-1.60	.08-.10	.30	.50-.70	low

Car Castings, Gray Iron—See also Brake Shoes and Car Wheels

64	2.20-2.80	und. .085	und. .70	und. .70
	1.40-1.80	.06-.08	.50-.80	.45-.60	.40-.65	3.50
	2.25	.050	.60	.75	3.50
	1.75	.070	.85	.60
Sug.	1.50-2.25	und. .08	.40-.60	.60-.80

Car Wheels, Chilled

51	.50-.70	.05-.07	.35-.45	.30-.50	.50-.75	3.50
171	.58-.68	.05-.08	.25-.45	.15-.27	.63-1.0
171	.73	.080	.43	.44	1.25	4.31
171	.86	.127	.35	.49	.92	3.47
126	.70	.100	.50	.40	.60	3.50
	.58	.141	.38	.48	.90	3.63
	.57	.101	.41	.42
	.68	.188	.36	.53
	.67	.170	.38	.81	.74	3.66
	.50-.60	.08-.10	.30-.40	.45-.55	.70-.80	3.50
Sug.	.46-.70	.08-.10	.30-.40	.50-.60	.60-.80	3.50-3.70

Car Wheels, Unchilled—See Wheels

Chemical Castings—See Acid Resisting Castings

Chilled Castings

Ref.	Silicon Per cent	Sulphur Per cent	Phos. Per cent	Mang. Per cent	Comb. Carb. Per cent	Total Carb. Per cent
135	.80-1.00	.09-.11	.50	.50
197	1.20-1.40	low	low
69	1.00	.08	.40	.75	3.25
65	1.35	.117	.60	.54	.65	3.00
	.50	.200	.45	1.50	3.00	3.00
	1.20	.090	.30	.50	1.20	3.20
	1.20	.080	.30	1.25	3.50
	.75	.090	.30	.30	3.00	3.20
Sug.	.75-1.25	.08-1.0	.20-.40	.80-1.2

Chills

105	2.07	.073	.31	.48	.23	2.64
Sug.	1.75-2.25	und. .07	.20-.40	.60-1.0

Collars and Couplings for Shafting

	1.60	.040	.55	.55	.30	3.57
Sug.	1.75-2.00	und. .08	.40-.50	.60-.80

Cotton Machinery—See also Machinery Castings

	2.20-2.30	und. .09	.70	.60	.45	3.45
Sug.	2.00-2.25	und. .08	.60-.80	.60-.80

Crusher Jaws

135	.80-1.00	.09-.11	.50	.50
69	1.00	.080	.40	.75	3.25
	.50	.20	.45	1.50	3.00	3.00
Sug.	.80-1.00	.08-.10	.20-.40	.80-1.2

Cutting Tools, Chilled Cast Iron

65	1.35	.117	.60	.54	.65	3.00
Sug.	1.00-1.25	und. .08	.20-.40	.60-.80

Cylinders—See Air Cylinders, Ammonia Cylinders, Automobile Cylinders, Gas Engine Cylinders, Hydraulic Cylinders, Locomotive Cylinders, Steam Cylinders

Cylinder Bushings, Locomotive—See Locomotive Castings, Heavy

Diamond Polishing Wheels

105	2.70	.063	.30	.44	1.60	2.97
-----	------	------	-----	-----	------	------

Dies for Drop Hammers

171	1.40	.060	.10	.40
	1.40	.090	.40	.70	1.00	3.20
Sug.	1.25-1.50	und. .07	und. .20	.60-.80	low

Dynamo and Motor Frames, Bases and Spiders, Large

171	1.95	.042	.40	.39	.59	3.82
	1.90	.08	.47	.60	.64	3.79
	2.15	.070	.75	.60	.55	3.80
	2.10	.070	.55	.40	3.50
Sug.	2.00-2.50	und. .08	.50-.80	.30-.40	.20-.30	low

Dynamo and Motor Frames, Bases and Spiders, Small

171	3.19	.075	.89	.35	.06	2.95
	2.30	.070	.55	.40	3.50
	2.50	.070	.75	.60	.55	3.95
	2.10	.070	.55	.40	3.50
	2.30	.070	.55	.40	3.50
Sug.	2.50-3.00	und. .08	.50-.80	.30-.40	.20-.30	low

Eccentric Straps—See Locomotive Castings and Machinery Castings

Electrical Castings

171	3.19	.075	.89	.35	.06	2.95
171	1.95	.042	.40	.39	.59	3.82
	1.90	.080	.47	.60	.64	3.79
	2.15	.070	.75	.60	.55	3.80
	2.50	.070	.75	.60	.55	3.95
	2.10	.070	.55	.40	3.50
	2.30	.070	.55	.40	3.50
Sug.	2.00-3.00	und. .08	.50-.80	.30-.40	.20-.30	low

Engine Castings—See Bed Plates, Engine Frames, Fly-wheels, Locomotive Castings, Machinery Castings, Steam Cylinders

Engine Frames—See also Machinery Castings

ite. Its effects on the strength and ductility of cast iron are relatively unimportant.

Oxygen probably exists in cast iron and causes lack of fluidity, weakness, brittleness, unsoundness, etc.

White iron is most liable to this trouble. The variable quality of different brands of iron may be due to more or less oxygen.

Deoxidizing agents, titanium, vanadium, aluminum, manganese and silicon may be used.

Little is known regarding the effects of nitrogen on cast iron. If present in any quantity it probably causes weakness and brittleness. It exists in iron as a nitride and can be removed by means of titanium.

Aluminum is sometimes added to cast iron. A few tenths per cent. causes finer grain, freedom from blowholes, decreases the tendency to chill, decreases the hardness, increases the strength, improves the elasticity. These effects are probably due to its deoxidizing power. Large amounts of aluminum decrease fluidity and increase combined carbon.

Titanium is used as a deoxidizer. It may be added to cast iron as ferro titanium alloy in the cupola or in the ladle, or as titanium thermite in the ladle.

Dr. Moldenke's experiments show 52 p.c. increase in strength for gray iron and 18 p.c. increase for white iron which has been treated with titanium. Only .05 p.c. titanium is necessary.

Titanium does not affect hardness or shrinkage of gray iron but on white iron lessens the death of chill and makes the remaining chill much harder.

Vanadium may be added to cast iron as a ferro vanadium alloy. Dr. Moldenke's experiments indicate that small amounts greatly increase the strength of cast iron, especially of white iron. It is also thought to increase the resistance to shock.

Properties of Cast Iron.

The strength of cast iron is dependent upon nine factors: 1—p.c. graphite; 2—size of graphite flakes; 3—p.c. combined carbon; 4—size of primary crystals of solid solution, Fe-C-Si; 5—amount of dissolved oxide; 6—p.c. phosphorus; 7—p.c. sulphur; 8—p.c. silicon; 9—p.c. manganese.

The best method of reducing graphite is to reduce total carbon by the use of low carbon pig iron, by melting in the air furnace, or by the use of steel scrap in the cupola mixture. The chief difficulties in making semi-steel are, trouble with blowholes, high shrinkage, imperfect mixture of steel and iron, and absorption of carbon in the cupola.

The size of graphite flakes accounts for many cases of difference in strength

of irons of the same composition. The factors influencing the size are very poorly understood. Among them may be rate of cooling, pouring temperature, time which iron has remained in the molten state, presence of dissolved oxide, presence of steel scrap in the mixture, mixture of different brands, nature of ore from which iron is made, and treatment in the blast furnace, per cent. metalloids.

From analogy with steel combined carbon probably increases the strength of cast iron up to about 9 p.c., beyond that, decreasing it again.

Size of primary crystals of solid solution Fe-C-Si should, by analogy with steel, be important. This is uncertain.

The effect of dissolved oxide is probably important. To reduce oxide we may get the best brands of pig iron, avoid oxidizing conditions in the cupola, and use deoxidizing agents.

Phosphorus lessens strength, particularly resistance to shock. 1 p.c. produces a marked effect.

Sulphur may indirectly strengthen iron through decreasing the graphite, but is more likely to weaken it through causing blowholes and high shrinkage.

Silicon and manganese act chiefly indirectly. Silicon should be kept as low as possible and still have the necessary softness. Manganese should be high but if too high produces weakness.

Practical rules for making strong castings and a table of analysis of strong irons are given.

Of the elastic properties only toughness and elasticity are important in cast iron. The sum of these properties is given by the deflection. The factors influencing them are about the same as those influencing strength. Practical rules for obtaining the maximum toughness and elasticity and a table of very tough irons are given.

Maximum rigidity with the least sacrifice of strength and toughness is obtained through the use of manganese and combined carbon.

Hardness is due both to combined carbon and gamma solid solution. The latter explains the cases of hard cast iron which are yet low in combined carbon.

Phosphorus has only a slight hardening effect. Manganese may soften iron through its action on the sulphur, but in larger amounts will harden it. Sulphur is an energetic hardening agent. Silicon softens iron due to its action in decreasing combined carbon up to a certain point. Beyond this point it hardens, due to its direct action. The relationship between hardness and silicon is shown by a diagram.

Combined carbon is the chief hardening agent in cast iron. Gamma solid

solution is formed by rapid cooling from above 1300 deg. Fahr. and may cause hardness in some cases.

In chilled iron the factors influencing the depth and quality of the chill are, pouring temperature, and percentage of silicon, sulphur, phosphorus and total carbon.

The higher the pouring temperature the deeper the chill. A table showing the relation between the per cent. silicon and the depth of chill is given. Sulphur causes a brittle chill and is undesirable. Phosphorus injures the strength of chill and causes a sharp line between the white and gray portions. Manganese increases the hardness of the chill and its resistance to heat strains.

The grain structure and porosity depend on the size and percentage of the graphite. Practical rules for getting close grained, dense iron are given.

The term shrinkage includes contraction of the fluid mass or "shrinkage" and contraction of the solid mass or "contraction."

The mechanism of fluid contraction is not well understood. It is less the greater the amount of graphite. The tendency to form shrink holes bears little relation to chemical composition but varies in different brands of iron. A means in testing this tendency is described.

Shrinkage curves showing the manner the solid mass contracts are given. The first expansion is due to the separation of graphite. The second expansion is due to the solidification of the phosphide eutectic. The third expansion is probably due to the change of the iron from the alpha to gamma form.

Rules for obtaining minimum shrinkage are given.

The fusibility of cast iron depends primarily on combined carbon, and to a less extent, on the phosphorus. Graphite affects the melting point only in so far as it dissolves in the iron at temperatures below the melting point. A diagram and table are given showing the experimental results of Dr. Moldenke.

Fluidity is determined by per cent. silicon, per cent. phosphorus, freedom from dissolved oxide, and temperature above the freezing point. Practical rules for obtaining fluid iron are given.

The factors affecting resistance to heat are, per cent. phosphorus, sulphur and combined carbon, the density or closeness of grain.

Cast iron undergoes a permanent expansion on repeated heatings. It may increase as much as 46 p.c. by volume. The strength is decreased proportionately. A minimum temperature of 1200 deg. F. is necessary. The growth is favored by the presence of graphite and silicon. This growth is probably

Gears, Medium

Ref.	Silicon Per cent	Sulphur Per cent	Phos. Per cent	Mang. Per cent	Comb. Carb. Per cent	Total Carb. Per cent
64	1.50-2.00	und. .08	.35-.60	.50-.80
171	1.90	.060	.10	.40
	2.30	.060	.60	.60	3.75
	1.90	.100	.69	.58	3.83
Sug.	1.50-2.00	und. .09	.40-.60	.70-.90

Gears, Small

198	3.43	1.42	.90
	2.00	.100	.50	.70	3.50
Sug.	2.00-2.50	und. .08	.50-.70	.60-.80

Grate Bars

195	2.75	low	low
	2.00	.085	.35	.53
Sug.	2.00-2.50	und. .06	und. .20	.60-1.0	und. .30	low

Grinding Machinery, Chilled Castings for

Sug.	.50-.75	.15-.20	.20-.40	1.50	3.00	3.60
------	---------	---------	---------	------	------	------

Gun Carriages

171	.94	.050	.44	.31	.63	3.03
171	1.00	.050	.30	.60	1.10	2.50
Sug.	1.00-1.25	und. .06	.20-.30	.80-1.0	low

Gun Iron

171	1.34	.003	.08	1.00	.93	3.12
171	1.19	.055	.41	.42	1.13	3.18
171	1.53	.050	.29	.45	.42	3.43
171	.98	.06	.43	.43	.75	1.74
198	.3044	3.55	1.70	3.90
	1.20	.100	.30	.80	1.00	3.00
Sug.	1.00-1.25	und. .06	.20-.3080-1.0	low

Hangers for Shafting

Sug.	1.50-2.00	und. .08	.40-.50	.60-.80	3.57
------	-----------	----------	---------	---------	-------	------

Hardware, Light

198	1.8458	1.04
198	2.2074	1.10
198	2.50	1.21	1.16
	2.51	.110	.62	.41	.24	3.18
	2.70	.030	.60	.50	.40	3.60
	2.50	und. .050	.60	.70
	2.00-2.25	.050	.85	.40	3.85-4.00
Sug.	2.25-2.75	und. .08	.50-.80	.50-.70

Heat Resistant Iron

171	1.20	.060	.10	.40
171	1.67	.032	.09	.29	.43	3.87
134	2.15	.086	1.26	.41	.13	3.30
134	2.02	.070	.89	.29	.84	3.60
198	1.53	.040	.33	1.08	.58	3.68
105	2.07	.073	.31	.48	.23	2.64
81	1.80	.030	.70	.60
195	2.75	low	low
194	2.50	und. .07	und. .20	.80-1.0
	1.76	.075	.63	.79	.56	3.68
	2.00	.030	.70
Sug.	1.25-2.50	und. .06	und. .20	.60-1.00	und. .30	low

Hollow Ware

Sug.	2.25-2.75	und. .08	.50-.70	.50-.70	3.18
------	-----------	----------	---------	---------	-------	------

Housings for Rolling Mills

Sug.	1.00-1.25	und. .08	.20-.30	.80-1.0	low
------	-----------	----------	---------	---------	-------	-----

Hydraulic Cylinders, Heavy

71	1.00	.050	.30	.60	1.10	2.50
22	.90	.136	.39	.25	1.44	3.34
63	.80-1.50	.07-.11	.35-.50
	1.12	.085	.40	.70	.70	3.50
	.95	.100	.30	.90	.80	3.40
	1.15	und. .08	.50	.60	1.15
	.90-1.20	.06-.08	.30-.50	.80-1.0	.80-1.0	2.90-3.10
Sug.	.80-1.20	und. .10	.20-.40	.80-1.0	low

Hydraulic Cylinders, Medium

171	1.40	.060	.10	.40
	1.90	.074	.50	.65
	1.62	.08	.50	.60
	1.75	.070	.40	.55	.50
Sug.	1.20-1.60	und. .09	.30-.50	.70-.90	low

Ingot Molds and Stools

171	1.20	.060	.10	.40
171	1.67	.032	.09	.29	.43	3.87
Sug.	1.25-1.50	und. .06	und. .20	.60-1.0

Locomotive Castings, Heavy

57	1.40-2.00	und. .085	und. .60	und. .70
	1.25-1.50	.06-.08	.40-.60	.45-.60	.50-.70	3.50
	1.62	.098	.40	.49
Sug.	1.25-1.50	und. .08	.30-.50	.70-.90

Locomotive Castings, Light

57	1.40-2.00	und. .085	und. .60	und. .70
	1.50-2.00	.06-.08	.40-.60	.45-.60	.45-.55	3.50
Sug.	1.50-2.00	und. .08	.40-.60	.60-.80

Locomotive Cylinders

126	1.25-1.75	und. .10	und. .90
57	1.40-2.00	und. .085	und. .60	und. .70
	1.25-1.50	.06-.08	.40-.60	.45-.60	.50-.70	3.50
	1.00-1.40	und. .11	.40-.90	.40-.90
	1.41	.092	.38	.39
	1.56	.061	.45	.78
Sug.	1.00-1.50	.08-.10	.30-.50	.80-1.0

Locks and Hinges—See Hardware, Light

Machinery Castings, Heavy

Ref.	Silicon Per cent	Sulphur Per cent	Phos. Per cent	Mang. Per cent	Comb. Carb. Per cent	Total Carb. Per cent
171	1.05	.110	.54	.35	.33	2.98
178	.85	.030	.35	.92
63	.80-1.50	.030-.050	.35-.50
	.90-1.50	.09-1.2	.15-.40	.20-.80	.10-.30	2.50-2.90
	1.85	.100	.50	.60	3.50
	1.30	.090	.40	.60
	1.85	.120	.60	.45	3.40-3.55
	1.75	.100	.50	.70	.80	3.65
Sug.	1.00-1.50	und. .10	.30-.50	.80-1.0	low

Machinery Castings, Medium

171	1.83	.078	.50	.31	.43	2.93
	2.25	.080	.55	.60
	1.60	.060	.66
	2.29	.071	.66	.49
	1.60	.090	.50	.60
	2.10	.110	.67	.50	3.40-3.55
	2.25	.060	.75	.55
	2.00	.100	.75	.50	.75	3.50
	1.76	.075	.63	.79	.56	3.68
	2.00	.100	.50	.50	.50	3.60
	2.35	.075	.45	.65	.30
	1.80	.060	.80	.50	.70
	2.06	.075	.78	.47	3.45
	1.40	low	.20	.40
	2.00	.030	.70
	1.85	.08	.60	.50-60	.50	3.25-3.50
	1.50-2.10	.08-.09	.40-.80	.20-.60	.10-.40	2.60-3.20
	1.80-2.10	und. .09	.40-.90	.40-.90
Sug.	1.50-2.00	und. .08	.40-.60	.60-.80

Machinery Castings, Light

171	2.04	.044	.58	.39	.32	3.84
	2.25	.080	.70	.50	.20	3.55
	2.76	.037	1.1913	3.66
	2.49	.097	.90	.42	3.40
	2.51	.084	.62	.61	3.46
	2.50	.100	.60	.70	3.50
	3.00	.060	.65	.50	3.50
	2.40	.050	.47	.59
	2.85	.064	.67	.65
	2.52	.062	.66	.68
	3.15	.050	.70
	2.50	.100	.70	3.40-3.55
	2.20-2.80	.06-.08	.60-1.3	.20-.40	.10-.60	3.00-3.60
Sug.	2.00-2.50	und. .08	.50-.70	.50-.70

Machine Tool Castings—See Machinery Castings

Motor Frames, Bases and Spiders—See Dynamo

Molding Machines—See Machinery Castings

Mowers—See Agricultural Machinery

Niter Pots—See Acid Resisting Castings and Heat Resisting Castings

Ornamental Work

171	4.19	.080	1.24	.67	.03	2.88
	2.51	.110	.62	.41	.24	3.18
	2.2560-.90
Sug.	2.25-2.75	und. .08	.60-1.0	.50-.70

Permanent Molds

134	2.15	.086	1.26	.41	.13	3.30
134	2.02	.070	.89	.29	.84	3.60
Sug.	2.00-2.25	und. .07	.20-.40	.60-1.0

Permanent Mold Castings

93	2.00-3.00	3.00-4.00
	1.50-3.00	und. .06	und. .40

Piano Plates

197	2.00	low	.40	.60
Sug.	2.00-2.25	und. .07	.40-.60	.60-.80

Pillow Blocks

Sug.	1.50-1.75	und. .08	.40-.50	.60-.80	.30	3.50
------	-----------	----------	---------	---------	-----	------

Pipe

	2.00	.060	.60	.60
	2.00	.060	1.00	.60
Sug.	1.50-2.00	und. .10	.50-.80	.60-.80

Pipe Fittings

198	2.8841	1.10
	1.70	.058	.50	.73	1.16	4.18

iron castings, in the belief that such standards would be of great use both to the individual foundryman and to the industry as a whole.

"The information on which these should be based could, of course, be obtained by analyzing typical castings bought in the open market. This would, however, involve much trouble and expense, and will be unnecessary if foundrymen will freely donate the information for the good of the industry.

"We urge you, therefore, to act generously in giving us the data indicated below, and since composition is but one item in the successful manufacture of castings, we feel sure that in so doing there can be no possible detriment to your personal interests.

"Replies will, of course, be entirely confidential as regards the names of those giving information. There is desired the following information :

"Name or Class of Castings, Silicon, Sul., Phos., Mang., Comb. Carb., Graph. Carb., Total Carb."

To this letter about 10 per cent. of replies were received, the greater number of which contained more or less information.

Regarding the classification of castings, it is evidently impossible to consider as separate cases all the different patterns. Nor would this be desirable, since any foundry must itself class its castings into comparatively few groups which are each poured from one kind of iron. For example, a shop doing machine-tool work may make castings from several hundred patterns and will use not to exceed four mixtures of iron for all of these, probably dividing the work into light, medium and heavy castings, with possibly a special mixture for pulleys. It is thought, therefore, that a classification according to use or properties necessary is in the majority of cases desirable.

Thickness is, of course, taken into consideration, since this largely determines the percentage of silicon necessary, and it has been the aim to subdivide the various classes according to section wherever possible. In this respect the writer has endeavored to follow the definitions of the American Society for Testing Materials, who have grouped castings according to thickness as follows : (126).

"Castings having any section less than one-half of an inch thick shall be known as light castings."

"Castings in which no section is less than 2 inches thick shall be known as heavy castings."

"Medium castings are those not included in the above definitions."

It is unfortunately true that there is much lacking in this table, many important classes of castings being entirely missing, while others are inadequately represented by only one or two analyses. These deficiencies are due to the lack of available data in certain



Cores Shown at Detroit Foundrymen's Convention, Made With Peterson's Core Oil.

cases, and it is to be hoped that they may be at least partially remedied by future work.

Malleable cast iron is omitted entirely, partly because of the small amount of data obtained and partly because its manufacture is a process entirely different from those involved in the ordinary iron foundry.

Regarding arrangement, the analyses taken from published sources are preceded by a number in the first column referring to the bibliography, Part V. The last analysis under each head is preceded by the word "Sug." (abbreviated from suggested) and is the tentative standard or probable best analysis suggested by your committee. It should be clearly understood in this connection that while this is based on careful study of both theory and practice, it represents only the individual opinion of the writer, and is not necessarily infallible.

Furthermore, these suggestions are incomplete in certain other respects. The most desirable percentage of silicon, for example, will depend largely on the exact thickness of the casting and the practice followed in shaking out. These factors, being in many cases undetermined, have been allowed for by giving fairly wide limits to this element. Again, the possibilities in the use of purifying alloys have not been taken into account here, although they have been discussed in the preceding parts, and the use of steel scrap has been ignored except that the "low" total carbon specified in some cases must, as a rule, be obtained in this way. Finally in many cases, a very wide range of composition is permissible and compatible with the best results, and in such cases the question of cost will be the first element to be considered in fixing the composition.

PETERSON'S CORE OIL.

The T. J. Peterson Co., 6th floor, Security Building, Chicago, are placing their core oil on the Canadian market. This oil is used by some of the largest foundries in United States making automobile cylinder cores, radiator cores,

gasoline engine, malleable iron casting and general foundry cores.

At the Foundrymen's Convention at Detroit the T. J. Peterson Co. had an interesting exhibit of cores made by Detroit companies using their core oil. These are shown in the illustrations and show intricate cores made in the foundries of the Ideal Mfg. Co., Standard Foundry Co., E. M. F. Co., Sherwood Brass Works, and Buhl Malleable Co. The Aluminum Castings Co., who have under erection the largest aluminum foundry in the world, a description of which appeared in the August issue of this paper, are also users of Peterson's core oil. This fact will no

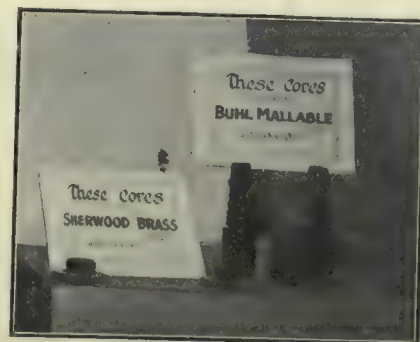

Cores Made With Peterson's Core Oil.

doubt be appreciated as aluminum castings are hard to make with core oil.

The T. J. Peterson Co. have branch offices in New York and Buffalo from which Canadian orders will be supplied. H. S. Peterson is arranging to visit Canadian foundries and will demonstrate the core oils to anyone interested. A card to the Chicago office will receive the personal attention of H. S. Peterson. As the core oil sells at considerably less than linseed oil no doubt Canadian foundrymen will be interested in this core oil.

INDUSTRIAL ^A_N^D CONSTRUCTION NEWS

Establishment or Enlargement of Factories, Mills, Power Plants, Etc.; Construction of Railways, Bridges, Etc.; Municipal Undertakings; Mining News.

Foundry and Machine Shop.

VANCOUVER.—The B. C. Electric Railway will build new carshops on the mainland to employ 1,000 hands.

BRANTFORD.—The Verity Plow Co. announce extensions for four departments of their Brantford works at a total outlay of \$60,000 for buildings and machinery. The present staff of 500 employees will be increased by 200, when the extensions are completed.

REGINA.—The contract for the new building of the Regina foundry has been let to T. Spray.

CHATHAM.—The Western Bridge & Equipment Co., contemplate building a new plant to accommodate their increased business.

VANCOUVER.—Final arrangements have been made by the Sumner Iron Works, of Everett, Wash., for the establishment of a plant at West Burnaby, where logging and other heavy machinery will be made.

WOODSTOCK.—The Canadian Linderman Machine Co., of Muskogon, capitalized at \$105,000 are locating here. The company will manufacture Dovetail glue and jointing machines for making boards out of wood scraps.

PORT DOVER.—The following new buildings will be immediately erected for the Widespread Implement Co. Planing mill (two storeys), 40 x 50 ft.; engine house, 20 x 25 ft.; foundry 34 x 37 ft.; and machine shop 37 x 50 ft.

BELLEVILLE.—The G.T.R. have commenced the construction of a roundhouse to accommodate 42 locomotives.

GALT.—R. McDougall Co. have completed an addition to their shops.

WALKERVILLE.—The Ford Motor Co., Detroit, is having plans drawn for a three-storey factory building, 60 x 100 ft., here, for the manufacture of automobiles.

SHERBROOKE.—Adolphe Lambert, Ed. Morency, A. Talbot, G. Rousseau, N. Rouleau and A. Turgeon are applying for incorporation from the Government under the name of the Robertsonville Foundry Co. The capital of the new company is \$20,000, divided in shares of \$1.00 (one dollar) each. The works of the new industry will be situated near the station of the Q.C.R.

LONDON.—Wortman and Ward, whose factory here was recently burned out, have bought four acres of land in the western part of Winnipeg, and will build a large factory there this fall. They have asked the Winnipeg City Council for a fixed assessment.

ST. CATHARINES.—In order to take care of the increasing demand throughout the Dominion for the Reo Thirty, the directors have decided to increase the capacity of the Canadian plant. Additional ground in the vicinity of the factory has been purchased and on it will be erected a modern two-storey brick building, 90 x 100 feet. Work on the erection will be begun at once. Machine tools to the value of \$20,000 have been purchased for installation in the new plant, and orders for material sufficient to build 600 four-cylinder cars have been placed. A majority of the orders for raw material are being placed with Canadian firms.

CHATHAM.—The International Harvester Co. has acquired control of the Chatham Wagon Co. by the purchase of practically the entire capital stock of the local concern, the deal being concluded last week. The Chatham Wagon

Co. was established in 1882 by Wm. Ball and the late D. R. Vanallen, has since been several times enlarged, and has a rapidly growing trade with the Northwest. Under the new regime the present plant will be very much enlarged and many new hands employed, though no definite announcement has been made as to the exact nature of extent of the proposed changes.

CHATHAM.—The Western Bridge & Equipment Co. is purchasing a 5-acre site here and will within six weeks commence the erection of a new 82 x 160 steel concrete factory. On the completion of the new factory, between 50 and 100 hands will be regularly employed.

LONDONDERRY, N.S.—The machine shop of the local plant of the Canada Iron Corporation has been destroyed by fire entailing a loss of \$15,000.

ST. JOHNS.—T. McAvity & Sons are considering the advisability of moving their foundry business west, and establishing a foundry and factory at Fort William. Representatives of the firm are going over the ground.

VANCOUVER.—Tucker & Co., Ltd., are being merged into a new concern called The Great Western Automobile Co., Ltd. The stockholders are all local.

DUNDAS.—The cotton mill property has been purchased for a new gasoline engine works. Extensive alterations are necessitated.

THREE RIVERS.—The foundry and machine shop of Bellefeuille & Frere were destroyed by fire. The loss will be about \$10,000.

FORT WILLIAM.—The G.T.P. have awarded to Carter-Halls-Aldinger Company, of Winnipeg, the contract for their roundhouse and machine shops on the Mission. The buildings will cost about \$100,000.

ST. THOMAS.—Architect N. R. Darrach has prepared plans for the additions and alterations to the Red Foundry (extension to Norseworthy Company's foundry). The plans provide for the erection of a brick building, 60 x 110 feet.

GUELPH.—Edgar Bloxham, representative of the Taylor Forbes Co., Guelph, at Paris, France, is on a visit to Canada, conferring with the principals of the company regarding export business of boilers and radiators to that country.

TORONTO.—The Canada Metal Company, have secured property in Winnipeg and expect to open a plant there in the near future.

CALGARY.—The Woodhall Metal Co., have occupied new premises in East Calgary. The building is large and spacious and fitted up with modern machines. It is the intention of the firm to extend the business and carry enamel ware and fancy hardware. The plant is possibly the largest of its kind west of Winnipeg. P. S. Woodhall is president of the company.

WELLAND.—Negotiations have been going on for some time and have just been concluded by which a million-dollar plant will be erected at Welland to employ 1,500 hands. The firm is Deere & Company, one of the largest concerns in the world, with head office at Moline, Ill. The following industries are affiliated with Deere & Company:—John Deere Plow Company, Moline Waggon Company, Marseilles Sheller Company, Velie Carriage Company and Velie Motor Company. The products of the Welland factories will be harvesters, waggons, plows,

carriages, grain drills, harrows, disc harrows and other articles. The ground has been secured and a staff of 500 men will be required to construct the buildings.

Municipal Enterprises.

MOOSE JAW.—The city council instructed City Engineer Wilson to revise plans for the sewage disposal plant, and call for tenders to be in by October 17.

LONDON.—Gartshore-Thompson Co., Hamilton, were awarded the contract for special castings for the Horton St. pumping plant, at 4½ cents a pound.

CALGARY.—By-laws have been passed to raise \$284,000 for watermains; \$30,000 sewer connections, and \$125,000 for building and equipping an addition to the electric power plant.

VANCOUVER.—The contract for the supply of sewer pipe has been awarded to the Dominion Glazed Cement Pipe Co., Vancouver, at \$70.910.

ORANGEVILLE.—The by-law to procure a system of waterworks was carried.

WINNIPEG.—It is proposed to extend the high pressure system over many of the principal thoroughfares, at a cost of \$230,858.

OUTREMONT, QUE.—The council has awarded contracts for the construction of six brick and three tile sewers at an approximate cost of \$60,000.

TORONTO.—Premier Whitney has given the mayor assurance that the proposed expenditure of \$40,000 for the extension of the intake pipe for a distance of 500 feet into the lake will receive government sanction.

CASTOR, ALTA.—A new waterworks system is to be installed at an estimated cost of \$85,000.

HALIFAX.—It is proposed to erect a reservoir for the high pressure service system.

OTTAWA.—The installation of additional street hydrants for fire protection is contemplated.

STRATHCONA.—The ratepayers voted in favor of extending its sewerage and water systems at a cost of \$48,000.

YORKTON.—The contract for the construction of sewers was awarded to N. B. McInnis, Regina.

VANCOUVER.—J. C. Kennedy was awarded the contract for the laying of the Tenth Avenue sewer, at \$48,700.

TORONTO.—The Board of Control has instructed the city engineer to report on the cost of constructing storm sewers to relieve the present system in time of flood.

ESQUIMAULT.—A committee has been appointed to gather all available data on the installation of a sewerage system.

COATICOOK.—The contract for the new reinforced concrete bridge has been let to Nomer & Winstanley.

ST. MARY'S.—The contract for the Fulton Bridge, which is to be a reinforced concrete structure, has been let to Jos. Patterson, for \$670.

VANCOUVER.—The Dominion Glazed Concrete Pipe Co. has secured the contract for pipe for sewer purposes during the coming year, the figure submitted being \$70,910. Two other tenders were submitted, these being for the clay article, one from Evans, Coleman & Evans at \$76,930.50, and the other from C. Gardiner Johnson & Co. at \$75,261.50. The contract awarded yesterday

The Ideal Friction Clutch and Cut-off Coupling

A perfectly balanced Clutch with big power for its size due to large friction surfaces and powerful lever movements

IT is easily adjusted to suit any load up to its rated h.p. and it is perfectly safe because it cannot start when out of gear. Levers and draw bolts are made of steel and do not break. It can be used with either wood or iron pulleys as desired. It is provided with either solid iron sleeve or split babbitted sleeve, interchangeable without disturbing the mechanism.

We make Castings, Engines, Boilers, Tanks, and Sheet Metal Work of all kinds, Mining and Brick Machinery.

The Berg Machinery Manufacturing Co., Limited

Bathurst and Niagara Streets, TORONTO

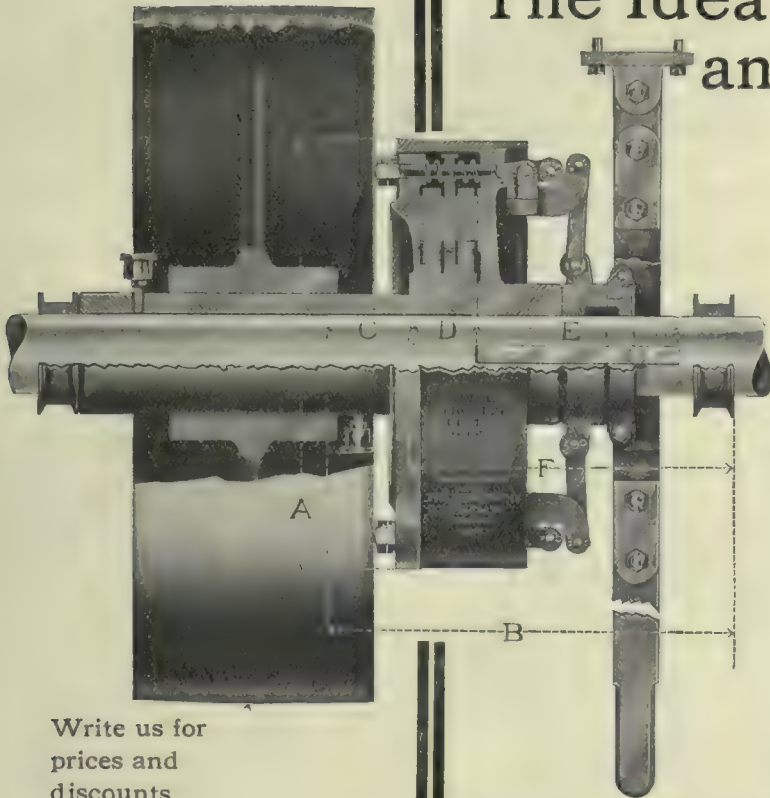

Write us for prices and discounts

5⁰⁰
A DAY

YOUR SPARE TIME!

Are you making any use of your spare time? Most everyone is willing to do a little extra congenial work if the way is made plain and the money good enough.

EARN \$5.00 A DAY!

Sounds big, eh? But it's not more than you can earn working for

BUSY MAN'S MAGAZINE

CANADA'S LEADING MONTHLY.

We want Salaried Agents in every town. Are you going to be the first in your district? We give a most liberal commission on all orders.

Subscription, \$2.00 per year. Write for details of our proposition and DO IT NOW.

Busy Man's Magazine, UNIVERSITY AVE. TORONTO

5⁰⁰
A DAY

5⁰⁰
A DAY

Don't fail to mention "Canadian Machinery" in writing to advertisers.

calls for pipe all the way from four inches in diameter upwards. On the four-inch article the price is the same as for the older clay style but above that size the city saves on every foot in the quotations submitted by the Dominion Company, the reduction running from 35 to 50 cents per foot above the 12-inch size. This latter condition is accounted for by the fact that when the clay pipe is laid over the 12-inch diameter, it has to be encased in cement, a precaution not necessary when the glazed concrete article is used.

BELLEVILLE.—The tender of the Canada Foundry Co. for an electric pump for the waterworks has been accepted. It is to be a two and three stage turbine, with capacity of 70,000 gallons per hour, driven by a motor of 115 horse-power.

TORONTO.—Additions and alterations to the high level pumping station are now open to tender.

ESTEVAN.—Tenders are being called for the electric light and sewer system, including pipe laying, power-house, boilers, engine, electrical equipment and sewers.

CHARLOTTETOWN.—Electric lighting tenders are being called for.

BRANDON.—The hospital board has decided to instal a big steam heating plant to cost from \$7,000 to \$8,000. The plant will include two seventy-five horse-power boilers.

MONTREAL.—Tenders for the new intake pipe are being called for Sept. 14 as a good section of the work must be completed before winter.

OUTLOOK, SASK.—Ratepayers carried the \$25,000 waterworks by-law.

MOOSE JAW.—The \$375,000 by-law for sewer and waterworks extensions was carried.

SWIFT CURRENT.—By-laws for sewerage, sewage disposal and water supply were carried.

LETHBRIDGE.—The by-law for the expenditure of \$148,000 on waterworks and sewers, was carried.

MEDICINE HAT.—A by-law to expend \$45,000 on waterworks extensions has been submitted to the ratepayers on Aug. 15.

COLLINGWOOD.—It is probable that a by-law will be submitted for authority to spend about \$5,000 on the increase of the water supply.

WINNIPEG.—Pavements, walks and sewers, totalling \$224,506, were passed by the council at last meeting and will be advertised for tenders.

SASKATOON.—The tender of the Robb Engineering Co., for the 250 h.p. water tube boiler, to cost \$4,756, has been accepted.

LONDON.—Tenders for the new pumping station at Springbank are to be awarded in the near future.

MONTREAL.—The matter of purchasing the plant of the Montreal Water and Power Co. is again under discussion.

MONTREAL.—An expenditure of \$250,000 is contemplated for the laying of water mains in the newly annexed wards.

MONTREAL.—Instructions have been given to have the smoke by-law observed. Smoke consumers must be installed where soft coal is used in quantities.

Electrical Notes.

PETERBOROUGH.—The capital stock of the Auburn Power Co., of Peterborough, Ltd., has been increased from \$99,000 to \$500,000.

MONTREAL.—It is stated on good authority that the Montreal Street and Canadian Power

WHITE METAL
PRESSURE DIE
 NO MACHINE WORK NECESSARY—WRITE FOR FACTS
LUMEN BEARING CO., TORONTO

BETTER RESULTS AT LOWER COST

can be secured for any class of castings by arranging your mixtures by analysis. Years of practical experience in foundry work are at your service when you consult with

The Toronto Testing Laboratory, Limited

18 SATURDAY NIGHT BUILDING, TORONTO

EXPERT FOUNDRYMEN, METALLURGISTS, CHEMISTS

TESTS OF METALS, FUELS, CORES, OILS, Etc., AT REASONABLE PRICES.

**BEST
LEATHER
BELT
MADE**

TORONTO MONTREAL WINNIPEG
ST. JOHN, N.B. VANCOUVER



The Utilization of Wood Waste by Distillation

A general consideration of the NEW INDUSTRY, including a full description of the distilling apparatus used and the principle involved, also methods of chemical control and disposal of the products, first edition illustrated by seventy-four engravings, 156 pages. This book is cloth bound, it will be sent to any address post paid on receipt of \$3.20.

MAKE SOLIDIFIED PURE MILK VACUUM DISTILLED SOLID TABLETS WITH

Industrial Alcohol Stills, 5 Gal. Tax-Free, \$135.00, pays for itself every Month. 75 to 500 Gal. Stills installed under guarantee. Alcohol Solidified, 33 samples Solid Alkaloid Cubes, 194 proof, post-paid for \$1.00.

WOOD WASTE DISTILLERIES COMPANY

Wheeling, W. Va.,

U.S.A.

High Grade Malleable Castings

of all sizes and kinds

Galt Malleable Iron Co., Limited - Galt, Ontario

JOHN J. GARTSHORE
83 Front St. W., Toronto
RAILS and SUPPLIES
New and Second-hand
For RAILWAYS, TRAMWAYS, Etc.
Old Material Bought and Sold.

OPAL GLASS TILING
FOR WALLS OF
MACHINERY AND POWER HOUSES
Most approved material.
TORONTO PLATE GLASS IMPORTING CO'Y
PLATE AND WINDOW GLASS
135 to 143 Victoria St., - Toronto



Oil Tempered Steel Springs

—for every purpose and the best for each use.

—Special styles of all kinds to order.

THE CLEVELAND WIRE SPRING CO.
Cleveland, Ohio.

STEELCRETE
EXPANDED METAL
REINFORCEMENT for CONCRETE FLOORS and ROOFS.
The most reliable bond for all varieties of concrete slab.

WRITE FOR HAND BOOK AND SAMPLES

Competent Engineering staff in charge of construction.

Expanded Metal & Fireproofing Co., Limited
100 King Street West. TORONTO

MAPLE LEAF
STITCHED COTTON DUCK
BELTING
DOMINION BELTING CO. LTD.
HAMILTON CANADA

are to be merged, as the interests friendly to this merger have secured sufficient stock to have a controlling interest amounting to forty thousand shares.

OTTAWA.—In order to supply the increasing demand the city electric plant has made an agreement with the hydro-electric commission to obtain 1,500 additional horse-power from the Ottawa and Hull Power Co., making a total of 4,000. The city will build a conduit for the high voltage wires from the power house to the distributing centre.

SHERBROOKE.—As the Sherbrooke Power and Railway Company cannot come to an arrangement with power owners on the banks of the Magog, the company has given notice of expropriation. This property is required in connection with a dam that the company propose building.

OTTAWA.—A permit has been taken out by the Ottawa Electric Co. for a brick transformer station, to cost \$18,000. The various minor departments are to be located in this building as well.

FORT FRANCES.—An assessment of \$400,000 has been placed on E. V. Backus, president of the Minnesota and Ontario Power Co., for his improvements here.

VICTORIA, B.C.—The Hinton Electric Co., Ltd., has received from the corporation of Ladysmith the contract for the supply of all electrical materials in connection with the installation of the new Tungsten street lighting system in the coal city.

LISTOWEL.—The electrical supply business of G. P. Thomas has been purchased by E. Seger.

LONG BRANCH, ONT.—One hundred horse power has been contracted for, to be supplied by the Erindale Power Co.

BELLEVILLE.—It is announced that the Healey Falls Development Co. has sold its property at Healey Falls on the Trent River, to the Seymour Electric Power Co., and that the latter company will develop the power at that point.

BRANDON.—Work on the heating system that is being installed by the Brandon Electric Light Co., is under way, and it is expected that it will be completed by Oct. 1.

SASKATOON.—Contracts have been let to the Northern Electric Co., for the supplying of wire and electrical supplies.

NIAGARA FALLS.—The plans for exporting Niagara power from Windsor to Detroit have fallen through, due to the United States law being contrary to this procedure.

PETERBOROUGH.—Tenders for the new power station at Auburn are being let by the Peterborough Radial Railway Co.

COBOURG.—A meeting of the shareholders of the old Northumberland-Durham Co. ratified the sale of the company's water powers to the Seymour Electric and Power Co., and wound up the affairs of the company. The sale price was \$250,000.

TILSONBURG.—By a vote of 324 to 61 the ratepayers endorsed the by-law providing \$25,000 to distribute hydro-electric in the municipality.

OTTAWA.—The difficulty concerning the water power along the line of the Trent Valley Canal has been settled by the Department of Railways and Canals. At dam No. 2 the power goes to the Trent Power Co., to be arranged between themselves. Five thousand horse power to be reserved for the Town of Trenton. At dam No. 1 the power is to be allotted free to the Trenton Power Co., the Trenton Electric Light and Water Co., and the town of Trenton.

New Companies.

Power Economics, Ltd., Montreal; capital \$20,000; to manufacture machinery; by H. T. Henneker, A. H. Duff, W. S. Johnson and others.

Canadian Brodesser Mfg. Co., Winnipeg; capital \$150,000; to manufacture elevators. The new company has taken over all the patents and patterns, etc., of the Brodesser Elevator Mfg.

SPECIAL MACHINERY, Etc.

ARMSTRONG BROS.
16 Sheppard St., Toronto
Mfrs. of **SPECIAL MACHINERY**
Patents Perfected
GEAR CUTTING, TOOLS, DIES, ETC.
Ruching and Pleating Machinery.

ERNEST SCOTT
91 BLEURY ST., - MONTREAL
Machinist and Tool-maker
Dies for sheet metal work. Stampings and light manufacturing. Special machinery designed and made to order.

The PARMENTER BULLOCH CO., Ltd.
GANANOQUE, ONT.
Iron and Copper Rivets, Iron and Copper Burrs Bifurcated and Tubular Rivets, Wire Nails, Copper and Steel Boat and Canoe Nails, Escutcheon Pins, Leather Shoe and Overshoe Buckles, Felloe Plates.

OWEN SOUND IRON WORKS, LIMITED
OWEN SOUND, ONT.
Cement Mill Machinery, Boiler and Steel Tank Work of all kinds, Grey Iron and Brass Castings

PATTERNS AND MODELS
PATTERNS IN WOOD
~ALL KINDS~
Difficult Core Work a Specialty
High Grade - Right Prices - Prompt Delivery
SATISFACTORY WORK GUARANTEED
THE HAMILTON PATTERN WORKS
258 CATHERINE STREET NORTH
HAMILTON, ONT.

PATTERNS
Patterns and Models All work guaranteed.
of any design. Correspondence Solicited.
JAMES SIBLEY
Mechanical Draughtsman and Patternmaker.
156 DUKE STREET, TORONTO
Phone Main, 5747.

Castings
TOUGH, STRONG, GREY
IRON CASTINGS, EASILY
MACHINED.
Any size up to ten tons
Wm. Hamilton Co., Ltd.
PETERBORO, ONT.

BENCH POWER PRESS



New Design

Particularly adapted for small, quick work, to take place of foot presses.

Write for Prices.

W. H. Banfield & Sons

MACHINISTS, DIE AND TOOL MAKERS
120 Adelaide Street West
TORONTO - - - CANADA

Special Taps Special Dies Special Reamers

Unless you have special appliances, you can get these tools from us better and cheaper than you can make them.

We have the equipment and the experience. Ask us for prices.

A. B. JARDINE & CO.
HESPELER, ONT.

Co., of Milwaukee, Wis. The president of the company is to be Montague Aldons; vice-president, V. V. Richardson; secretary-treasurer, G. Laing. These officers are all well-known western business men, and, with expert operatives, who have been brought in from the large works of the Brodessa Company, of Milwaukee, the success of the new Canadian company is assured.

The Health Canopy Bed and Mfg. Co. have been incorporated with headquarters in Ottawa to make collapsible cots and beds. The capital is \$100,000 and the incorporators, A. G. Cole, Barrett P. Dewar, Alf. Stewart, W. L. Scott and C. H. MacLaren.

Marx & Rawolle, of Canada, Montreal; to manufacture, refine and deal in glycerine, shellac, varnish and oils. Incorporators, R. C. Smith, F. H. Markey, W. W. Skinner, Montreal.

Gas Producer Co., Ltd., capital, \$1,000,000; to manufacture and deal in all kinds of apparatus for refining, heating, recovering, producing, and obtaining gas and oil of all kinds, and to manufacture, refine, treat, recover, produce, obtain, buy, sell, trade, and deal in gas and oil of all kinds. Incorporators, E. B. Ryckman, C. S. MacInnes, C. C. Robinson, E. B. Coleman and A. E. Lloyd, all of Toronto.

Canadian H. K. Porter Co., Toronto; capital, \$50,000; to manufacture and deal in locomotives, cars, trucks, machinery, tools, iron, and steel work of all kinds. Incorporators, H. K. Porter, W. E. Lincoln, W. E. Martin, Pittsburg, U.S.A.

Gareau Motor Car Co., Montreal; capital, \$300,000; to construct and manufacture automobiles, motor vehicles and all kinds of motors, engines and machines. Incorporators, J. Therrien, N. Giroux, J. A. Therrien, Montreal.

The Sheet Metal Products Company of Canada, Limited, with head office at Toronto, has been incorporated. The incorporators include W. J. and H. A. Holliday, manufacturers, and H. H. Loosemore, banker, of Toronto.

"GLOBE" TIME RECORDERS

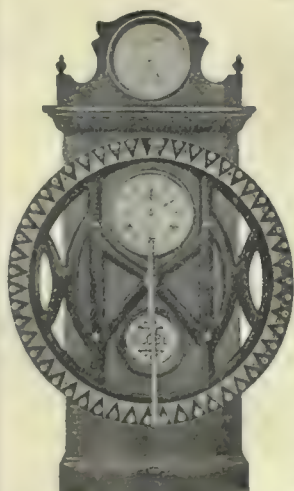

are made in Canada by expert mechanics. They are accurate, simple in construction, strong, and of good chaste appearance. They will record with absolute accuracy the arrival and departure of your employees (TO THE MINUTE), making you pay for what you get and no more. All lates and short time marked in red, regular time in green. The small cut at the top illustrates the WEEKLY MODEL, an entirely automatic recorder requiring no attention whatever during the week—as all changes, etc., occur automatically (DONE BY CLOCK WORK). The DAILY MODEL is shown in the cut at the bottom. This recorder is being used mostly in large shops, etc., where a large number of hands are employed. With the "GLOBE" TIME RECORDERS only one operation is required as against five with most others.

Inspection may be made through the glass sides of the case, but tampering with records is impossible, no danger of having soiled, torn or lost records when same are unfavorable,

as is the case with all CARD CLOCKS. We are now manufacturing over 224 DIFFERENT TIME RECORDING CLOCKS, and are in a position to meet the requirements of any business. Write us about your needs and let us suggest what will best meet with your requirements. WE SOLICIT YOUR ENQUIRY.

W. A. WOOD, Manufacturer

Head Office and Factory: 40 St. George St., Montreal

Branch Offices:

19 Bleury St., Montreal 65-67 Victoria St., Toronto



Structural Steel.

OTTAWA.—The contract for the substructure of the bridge over the Saskatchewan River at the Pas Mission has been let to Mackenzie and Mann, the contract figure being \$100,000. The contract for the superstructure of this bridge, which will constitute the first link of the Hudson Bay Railway, was let to the Canada Foundry Co.

EDMONTON.—Work on the big million-dollar high level bridge across the Saskatchewan, that is to connect Edmonton and Strathcona, the twin cities of northern Alberta, is to be commenced at once. The contract for the approaches and substructure, including all excavation, filling in and cement work, has been let by the C.P.R. to John Gunn & Sons, Winnipeg.

TORONTO.—Tenders are being called for the new steel viaduct on Queen St. E.

KAMLOOPS, B.C.—Plans have been prepared by direction of the minister of public works for the new bridge across the Thompson river at Walhachin. The work will be started this fall, and the bridge, a steel structure, will cost in the neighborhood of \$30,000.

VANCOUVER.—A by-law providing a sum of \$250,000 is being put through by North Vancouver, to defray the expenses of a bridge across the Second Narrows of Burrard Inlet. Two types of bridges are under consideration, one is to have a bascule span in the center of the Narrows and the other is to maintain the same general design, but to substitute a lift span in the centre for the bascule.

PORT ARTHUR.—The contract has been let, totalling \$30,000, for a reinforced concrete bridge over Current River, to facilitate transportation to the manufacturing district.

ST. JOHNS, QUE.—The loan of \$16,667 has been authorized for the construction of the bridge between St. Johns and Iboville across the Richelieu. Iboville is to advance half this amount.

Planing Mill News.

CRAWFORD, B.C.—The Nicola Valley Lumber Co., are to build a new mill.

NELSON, B.C.—W. H. Kreyseher, is organizing a company to rebuild his mill.

GALETTA, ONT.—The Canadian Cooperage Co. are figuring on erecting another stave and hoop plant.

LULU ISLAND.—The Barnet-McDonald mill, which was burned down last winter, will be rebuilt, probably next year.

CROFTON, B.C.—A lumber mill to cost \$750,000 is to be erected in this neighborhood as soon as a suitable site is selected. This was decided upon finally after a conference between R. Marpole, vice-president of the E. & N. railway and W. E. Marsh, representing the American Finance and Securities Co. A railway addition is to be built in conjunction.

Saw Mill News.

RIVER CHARLES, N.B.—The saw mill owned by C. I. Keith, was destroyed by fire recently with a loss of \$4,000.

RUSKIN, B.C.—The E. H. Heaps' lumber mill was destroyed by fire recently. The loss will be in the neighborhood of \$50,000. It is likely that the mill will be rebuilt.

REVELSTOKE.—The Dominion Saw Mills and Lumber, Ltd., is the title of a British Columbia corporation which is now raising \$4,000,000 on the London money market by an issue of 6 per cent. first mortgage debentures which will be secured on some 140 square miles of timber situated near Three Valley, a station on the main line of the C.P.R. a few miles to the west of Revelstoke. The authorized capital of the company is \$5,000,000.

Building Operations.

SACKVILLE.—B. C. Rayworth has commenced work on a new concrete machine shop and woodworking plant, which will be 35 x 60.

MONTREAL.—Contracts for the completion of the new C.P.R. station amounting to \$1,000,000, have been awarded to C. E. Deakin.

BATTLEFORD.—Tenders for the construction of the post office will be received until August 22, by R. C. Desrochers, assistant secretary, Department of Public Works, Ottawa.

PORT DOVER.—The Board of Education have decided to erect a new building for the use of the High and the Public school. The estimated cost is \$15,000 and it is expected that the building will be ready for occupation in about a year.

VANCOUVER.—The Electrical Construction Co., will erect a new business block to cost \$16,000.

PRINCE ALBERT.—N. H. Russell is erecting an abattoir.

TORONTO.—The Fairbanks-Morse Co., will build a warehouse.

TORONTO.—Thos West, will build a 4-storey brick factory, to cost \$15,000.

TORONTO.—Mason & Risch Co. will erect a 6-storey reinforced concrete brick and steel warehouse, at a cost of \$100,000.

ST. LAMBERT, QUE.—Application has been made from a shirt and collar manufacturing firm in Troy, N.Y., for erecting a factory to employ 400 hands.

OTTAWA.—A permit has been issued for the new factory for the Continental Bag & Paper Co. The building will be of solid brick, two storeys high, and will cost \$30,000.

FORT FRANCIS.—Peabody, Houteling & Co., Chicago, one of the largest pulp and paper manufacturing concerns in the United States, have decided to erect an immense mill here.

BERLIN.—The furniture factory of Baetz Bros. & Co. was completely destroyed by fire recently, with a loss of about \$30,000. The company will rebuild if the town will grant a loan.

SASKATOON.—The Hill Mfg. Co., whose sash and door factory was totally destroyed by fire recently, are considering rebuilding in the autumn so as to be ready for the next spring's trade.

OSHAWA.—The contract for the erection of the three-storey factory building addition for the

**MALLEABLE IRON
CASTINGS
PRATT & LETCHWORTH CO.
BRANTFORD ONTARIO**

ALUMINIUM

"The 20th Century Metal"

Lightest and most adaptable of the industrial metals. Fills a hundred purposes where the ordinary metals fail. Saves its cost over and over again by its lightness and easy working qualities

You can now get your Aluminium requirements promptly attended to by our clients, The British Aluminium Co., Limited, of London, the largest producers in the United Kingdom.

Sole Agents for Canada: Parke & Leith, 205 Yonge Street (Bank of Toronto Building) - - - Toronto.

INGOTS, BARS, SHEETS, RODS, ANGLES, ALLOYS, NOTCHED BARS, CORNICES, WIRE, CHANNELS, ETC.

To-day get Bulletin "D" on the varied uses of ALUMINIUM (Parke & Leith)

JESSOP'S BEST TOOL STEEL

"ARK" High-Speed Steel

THE FAVORITE BRANDS WITH USERS OF GOOD STEEL.
A LARGE ASSORTMENT OF SIZES IN STOCK.
JESSOP'S HIGH-GRADE FILES AND RASPS.

80 Bay St., Toronto, Ontario Jas. Robertson Co., Ltd.
Chas. L. Bailey, Agent. Montreal, Quebec

Reid-Newfoundland Company Jas. Robertson Co., Ltd,
St. John's, Newfoundland. St. John, New Brunswick

WM. JESSOP & SONS, Limited, Manufactory, SHEFFIELD, ENGLAND.

Crucibles are part of the expense of your foundry. It will pay you to be sure you're using the best.

Dixon's Crucibles

have a record of 83 years behind them. You will find them adapted to your melting.

Free booklet, 223-A, sent on request

JOSEPH DIXON CRUCIBLE COMPANY
JERSEY CITY, N.J., U.S.A.



THE BEYER WATCHMAN'S PORTABLE CLOCK



IS TAMPER PROOF and thoroughly reliable

Shall we send Particulars?

G. C. BREDIN, Sales Agent
252 Dundas St. London, Canada
Record Dials furnished for all machines.

Do Your Tumbling



in a Globe improved Tilting Tumbler and get finest results, quickest and cheapest. It is made in six sizes for all purposes for wet or dry work.

"GLOBE"
Dies and Stampings.
Special Manufacturing Contract Work.

If you want to get an interesting little magazine free, ask for "THE SIL-ENT PARTNER."

THE GLOBE MACHINE & STAMPING CO.
300 Hamilton Street, Cleveland, O.
Canadian Agent:
H. W. PETRIE, Front St. W., Toronto, Canada



"CUSHMAN" CHUCKS

For general machinists' use. Strong and durable and designed for hard service.

Our catalogue shows many styles and sizes and is sent free.

The Cushman Chuck Co.
Hartford, Conn., U.S.A.
Established 1892

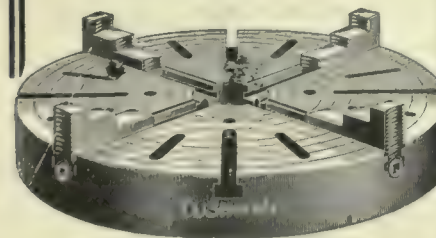

McLaughlin Carriage and Automobile Co., has been awarded to Robt. Bennet, Toronto.

NEW WESTMINSTER.—Work has been commenced on a wire nail factory which will give employment to one hundred men.

COBOURG.—The International Tool Steel Co., of Toronto, will build a plant in this town, and work on the new factory is to commence shortly. The estimated pay roll is \$25,000 a year, probably more. Tool steel will be manufactured.

Rumored Merger.

A charter is being applied for by a company under the name of the Steel and Radiator Co., Ltd., with a capital of \$5,000,000 for the avowed purpose of taking over the Expanded Metal Co., King Radiator Co., Dominion Radiator Co., all of Toronto, and the Taylor-Forbes Co., of Guelph. The promotion is in the hands of T. H. Brown, and the directorate is composed of Sir Henry Pellatt, Wallace Near, of the Page, Persey Co., Welland; M. J. O'Brien, Thos. Home, R. J. Cluff, and T. H. Brown.

The proposition is said to be to take over the Expanded Metal Co., and the King Radiator Co., first, giving them shares in the new company and then gradually absorb the other plants.

So many contradictory rumors are in circulation that nothing definite can be said.

Deere & Co., for Welland.

The Canadian plant of Deere & Co., with head works at Moline, Ill., and branch factories at numerous points in the United States, are going to build a million dollar plant at Welland and will employ upwards of 1,500 men in the manufacture of farm machinery. The firm was not granted a bonus.

Steel Corporation United Offices.

Street, Toronto, are being remodeled, and hereafter will be the Toronto offices of the Steel Corporation of Canada. The Montreal Rolling Mills' office in the Home Life building, and the Dominion Wire Co.'s office at 27 Wellington Street East, will be closed, and the staffs removed to Bay Street. No changes will be made in the representatives. Chas. G. Knott will, as usual, look after the Canada Screw Co.'s business; Jno. H. Webber, the Montreal Rolling Mills, and Thos. F. Hodgson, the Dominion Wire Co.'s. This is the first move towards amalgamation since the various companies formed their merger.

Eadie-Douglas, Ltd., Extend Agencies.

Under the management of G. M. Mulligan, formerly with Manning, Maxwell and Moore, New York, Eadie Douglas, Ltd., 12-14 University St., Montreal, with branch offices at 65 Victoria St., Toronto; 445 Main St., Winnipeg; and 81 Band St., Ottawa, have opened a mechanical and steam specialty department. The following firms are represented:—B. F. Sturtevant Co., manufacturers of fans blowers, ventilating sets, etc.; Shaw Electric Crane Co.; Platt Iron Works, manufacturers of the Smith-Vaile pumping machinery, condensers, etc.; Lenher Engineering Co., manufacturers of Taylor gravity underfeed stokers; Direct Separator Co., manufacturers of Sweet's steam and oil separators, exhaust heads, etc.; James Beggs & Co., manufacturers of Blackburn-Smith oil filter and grease extractor; Frank L. Patterson & Co., manufacturers of Berriman feed-water heaters, etc.; Linton Machine Co., manufacturers of combination feed-water heaters; Alphons Custodis Chimney Construction Co., manufacturers of radial brick and concrete machinery, and several other companies. Valves, boiler trimmings, engine room accessories, insulating specialties, etc., will also be handled.

Side Head of the Vertical Turret Lathe

A Big Factor in Reducing the Cost of Production of Many Kinds of Face Plate Work.

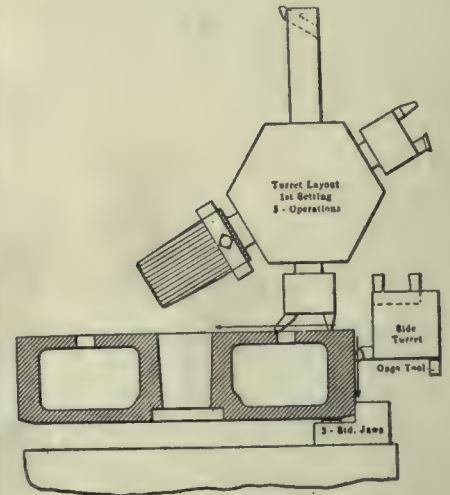

First Setting, First Operation.

Perhaps the greatest productive difference between modern and pre-modern machine tools is the doubling up or "tripling" up of cutting tools. One cut at a time is no longer sufficient to get competition-meeting results, and it was the realization of this fact that led to the designing of the Bullard Vertical Turret Lathe.

Besides the main turret head this machine has a side head which enables the operator to take simultaneous cuts on various surfaces. It does not interfere in any way with the operation of the main head.

The illustration herewith shows a job on which the Vertical Turret Lathe made a new record of 90 min.

The piece is a 27½ in. piston on which simultaneous cuts with the Side Head cut 30 minutes from the best previous time.

The Vertical Turret Lathe has two heads—a turret head and a side head—which allow two or more tools to be used at the same time.

All the tools needed for a whole series of operations are held in instant readiness.

In a word the Vertical Turret Lathe is a unique combination of the good points, the advantages of the vertical boring mill and the horizontal turret lathe.

Its vertical construction allows many a piece to be finished before it could be chucked ready for work on a horizontal turret lathe. For modern work—especially for duplicate pieces—the Bullard Vertical Turret Lathe is an innovation. It is a tool you must know about.

The entire sequence of operations on the piece shown here and other pieces is graphically illustrated in our new catalogue, which is free for the asking. Send for catalogue C-15.

The Bullard Machine Tool Co.
Bridgeport, Conn., U.S.A.

Large Order for Plows.

A contract to manufacture \$250,000 worth of plows, under the patent held by Dr. Rowntree, of Red Deer, has been awarded to the Edmonton Iron Works, of which T. J. Cornwall is the general manager. It covers a period of five years and calls for the manufacture of 1,000 plows per year. The contract will make necessary an extension of the plant on Kinistino Avenue to nearly double its present size and will mean the doubling of the present payroll. Mr. Cornwall will at once visit the east to order new equipment to the extent of \$10,000 for the manufacture of the plows.

New Works Started at Sydney.

The erection of new mills at the plant of the Dominion Iron & Steel Co., has been commenced. The area to be cleared is near the chemical company's plant and contains about 100,000 square feet of ground. The purpose of the excavation is to create a location for new or rather extended departments. When the ground has been prepared, foundations of concrete will be laid for a new machine shop and locomotive repair shop 500 by 130 feet, a foundry and blacksmith shop 500 by 130 feet, a boiler shop 250 by 130, a pattern shop and store house 300 by 60 feet, a warehouse 250 by 60 feet, and an oil house 150 by 60 feet. These buildings will be constructed of steel, and Sydney pressed brick and concrete. When these buildings are ready for occupation it is understood that the machinery at present in use will be transferred, with a large order of additional apparatus, from the original machine and other shops to the new ones. The old buildings will probably be removed to make way for new mills. The erection of a new acid house near the coke ovens department will also be shortly undertaken. This building will have twice the productive capacity.

New Car Shops for Montreal.

N. Curry, president of the Canadian Car Company, Montreal, was recently in Nova Scotia. To a reporter he said the railway development in Canada is so great that the output of cars from Canadian plants this year will exceed that of any preceding year by fifty per cent.

"During the present year," said Mr. Curry, "even if we book no further orders whatever, we have built or will build, 12,000 cars. Of this number 4,000 are already delivered. Our output, valued in money, amounts to between \$1,100,000 and \$1,200,000 per month. This statement includes all three of our plants. The orders for passenger cars have amounted to only 110. These go to the G.T.P., Canadian Northern, Temiskaming and Northern Ontario and some of the smaller roads," Mr. Curry made the announcement that his company is considering the erection in the near future, of a plant to be devoted to the building of steel passenger cars. He considers that the time will soon be reached when all cars will be constructed of steel. At present the proportion of steel utilized in the construction of cars is rather variable. In some cases the under frame is of steel, in others the top frame is of steel, but the majority of cars are composed chiefly of wood. The all-steel plant, Mr. Curry said, will be located in Montreal. It will stand close to the present plant. The surplus output of the rolling mill at Amherst is now being shipped to Montreal. This consists of bar iron and steel and malleable iron. With this outlet the Amherst shops are at present extremely busy. There are now 3,500 men on the pay roll of the three plants.

Steel Mills for B.C.

The Middlesborough Steel Strip and Hoop Co., Middlesborough, Eng., are interested in the project for establishing an iron and steel plant, including blast furnaces and rolling mills, in British Columbia. The plant is to be erected

close to deposits of magnetite at San Juan and Harris Creek, sixty miles northwest of Victoria. A sum of \$110,000 has already been spent in preliminary development work at San Juan, and there is now a shaft 300 feet down, with cross-cuts at 100-ft., 200-ft., and 300-ft. levels. High-grade magnetite has been found at the 100-ft. level, and the deposits are considered to be the largest workable on the Pacific slope.

Large Car Shops.

NEW WESTMINSTER. The British Columbia Electric Railway Co. is now considering the question of the erection of more extensive car shops at some point on the lower mainland where sufficient cars may be built to supply the growing demands of the system. It is estimated that shops giving employment to 1,000 or 1,200 men, will be required to fill the programme of car construction for the next few years which the company is now mapping out.

First Steel Craft at Winnipeg.

The first steel boat ever built on the Red River was launched yesterday. It was built for the Arctic Ice Co. by the Doty Engine Works Co. Its dimensions are as follows: Length, 70 feet; beam, 16 feet; depth, 6 feet, and its cost was \$15,000. It has 80-horse power, and is of the twin screw structure.

Copper and Brass Companies Unite.

The Booth Copper Co., of Toronto, and Wm. Coulter & Sons, brass manufacturers, Toronto, are to amalgamate, and an application will shortly be made to the Ontario Government to grant a charter to the Booth-Coulter Copper and Brass Mfg. Co., the name of the amalgamated concern. The capital will be \$1,000,000. No change will be made in the personnel of either companies for a while, at least. Coulter & Sons' brass works on George Street will be closed and the machinery transferred to the larger premises of the Booth Copper Co., on Sumach Street.

Brandon's Heating Plant.

The Brandon Electric Co. have started operations upon their heating plant. This will be the first venture of its kind in the Canadian west and will be watched with interest. The agreement between the Brandon city council and the Brandon Electric Light Co. states that the company will establish, maintain, and operate a public steam heating plant for a period of twenty years. The rates to be charged for heat, according to the agreement, will be \$1 per 1,000 pounds, on a monthly consumption up to 10,000 pounds, with a graduated reduction to any consumers using an excess of 10,000 pounds per month, according to the amount consumed; the minimum charge per month to be \$3 net.

Another Merger.

A Dominion charter has been granted to the Sheet Metal Products Co., of Canada, capitalized at \$5,000,000 with headquarters at Toronto. Considerable mystery surrounds its formation. Rumors have been prevalent for some time that the Metallic Roofing Co., Toronto, Metal Shingle & Siding Co., Preston; The Pedlar People, Oshawa, and the Galt Art Metal Co., Galt, were to be merged into one concern at the end of this year, and consequently the "Sheet Metal Products Co.," with its big capitalization has been connected with the proposed merger of metal roofing concerns. The lawyers who are the provisional directors of the company decline to give out any information, and J. O. Thorne, managing director of the Metallic Roofing Co., when asked for information stated that he was interested in learning all he could about the "Metal Products Co.," but said he could be quoted as saying that his company had no con-

ONE MAN can cut threads on 6-in. pipe with a "BEAVER" ADJUSTABLE DIE STOCK

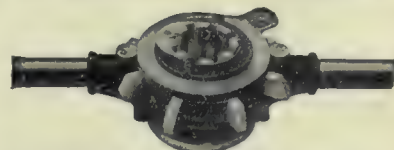

No. 6, threading 1-4, 3-8, 1-2, 3-4 in. complete.
No changing of Dies or Bushings.

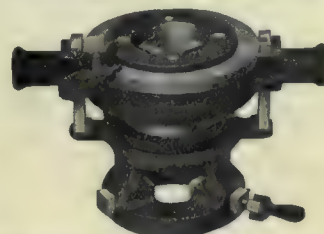

No. 25B, 1 in. to 2 in., R.H. complete.

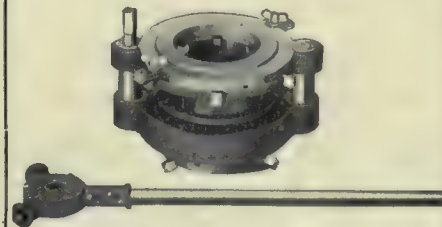

No. 60, cuts 2½, 3, 3½, 4, 4½, 5, and 6 inch pipe.

NOTE—That with the three tools shown above you can thread from 1-4 in. to 6 in. pipe. No loose parts.

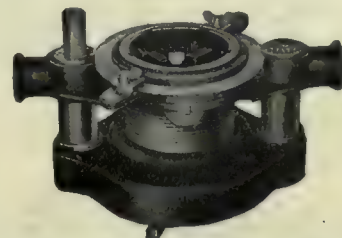

No. 41, cuts 2½, 3, 3½ and 4 in. pipe.



"WARREN" DIE STOCK

(Non-receding dies—adjustable.)

Each stock cuts two sizes. Made in four sizes.

Prices \$5.00, \$5.50, \$6.00 and \$7.00.

THEY SAVE TIME AND MONEY

Write for our Illustrated List

Borden-Canadian Co.
Richmond St. Eas', Toronto, Ont.

Test It At Our Expense

We wish to introduce the

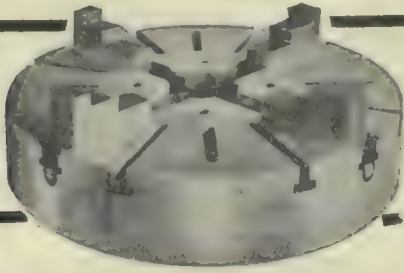

Imperial Chuck

to every shop in Canada, and if you will give an "Imperial" a fair trial, we will send YOU one at our expense and risk. Keep it thirty days, test and use it any way you can think, and if it won't answer every test you can apply, send it back at our expense.

WE know how good is the "Imperial;" won't you avail yourself of our offer?

Write us to-day.

Ker & Goodwin
Brantford, Canada

nection with the new concern. In his opinion it seemed probable that the new company was formed to take over the various stamped metal ware manufacturing plants. A. E. Kemp, of the Kemp Mfg. Co., when interviewed, was also eager for information but unable to throw any light upon the proposed "Sheet Metal Products Co."

Verity Plow Co. to Enlarge.

The following additions will be made to the Verity Plow Company's works, Brantford:

An addition to the warehouse, 200 x 60 feet, three storeys and a basement to be utilized both for warehouse and manufacturing purposes; an addition to the blacksmith department, 200 x 50 feet, one storey; an addition to the paint shop, 100 x 58 feet, one storey; the erection of a new core room, 50 x 60 feet, one storey.

The contracts for the extensions have been awarded. Eli Riddolls will build the black-

smith and paint shop, and Richards and Tindle the warehouse.

The outlay in connection with the extensions and the installation of new machinery will be \$600,000. The firm is now employing 500 men, and under the new conditions there will be room for 200 additional.

Gurney-Tilden Co., Reorganize.

A new charter taken out in the name of the Hamilton Stove and Heater Co., with a capital of \$600,000 has for its object the reorganization of the Gurney-Tilden Co. John H. Tilden, for many years president and general manager retires, and W. H. Carrick, formerly vice-president and general manager of the Gurney Foundry Co., becomes president and general manager of the new company.

The original intention of the new company was to take over the four stove foundries of Hamilton, namely: Gurney-Tilden Co., D. Moore Co., Burrow, Stewart & Milne, and Bower, Jamieson & Co., but although a couple of meetings were held, the promoters were unable to complete negotiations, and Mr. Carrick states that as far as his firm is concerned the merger is off.

Pender Nail Works Merged.

Sydney—Reports of the purchase by the Dominion Iron and Steel Co. of the Pender Nail Works, of St. John, N.B., have received confirmation from James Pender, the owner of the latter concern.

The scheme to purchase is part of the Dominion Iron and Steel Company's fight against the new Upper Canadian Steel combine, which has declared its intention of cutting into the local firm's business. The idea is to manufacture nails in the Maritime Provinces and ship right through to Western Ontario by cutting down the Company's steamers so that they can get through the locks into the Great Lakes.

Russell Machine Co.

MACHINE TOOL

AND

DIE MAKERS

First-class Workmanship

Prices Right

Estimates Furnished to the Trade

Russell Machine Co.

St. Catharines, Ont.

THE JOHNSON FRICTION CLUTCH

The Johnson Friction Clutch is so nicely balanced that it runs at any speed, high or low, without the least bit of vibration, bang, or clatter. The working parts are all completely covered so that no dirt can get at them.

By using Johnson Clutches you can use the Line Shaft direct for driving and thereby save not only in power, but in countershafts, pulleys, space and so on.

You will be interested in our "Book of Clutches that Clutch." Send for Catalog No. 5.

Canadian Agents:—CANADIAN FAIRBANKS CO.

Montreal Toronto Winnipeg Vancouver
Calgary and St. John

THE CARLYLE JOHNSON MACHINE CO. MANCHESTER CONN



Clutch with
Pulley on
Hub

Thor

AIR TOOLS ARE SUPREME

MECHANICALLY
AND ECONOMICALLY.

They are easily superior to all others in power, durability, ease of handling, economy of air consumption and general efficiency. THOR TOOLS are simple in construction; they run without vibration, and little attention and repairs are necessary. ADOPTED AS THE STANDARD IN THE PRINCIPAL PLANTS THROUGHOUT THE WORLD.

SENT ON THIRTY DAYS' TRIAL—express charges paid both ways if unsatisfactory. WRITE FOR DESCRIPTIVE MATTER.

Made in 50 different sizes, covering every possible Air Tool requirement. Exclusive Canadian Agents—H. W. PETRIE, LTD., 131 Front St. W., Toronto Cor. St. James and Little St. Antoine Sts., Montreal; 422 Abbot St., Vancouver.

INDEPENDENT PNEUMATIC TOOL CO.
CHICAGO NEW YORK PITTSBURG SAN FRANCISCO

MANGANESE BRONZE

LUMEN BEARING COMPANY, TORONTO

NORTHERN CRANES

These cranes have every recent improvement in crane practice and many exclusive features.

Bulletin Free.

All sizes and types—electric or hand.

NORTHERN ENGINEERING WORKS, Detroit, Mich., U. S. A.
or, Canadian Dept., ADVANCE MACHINE WORKS, Ltd., Walkerville, Ont.

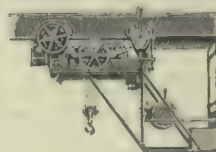

Electric Hoists Air Hoists

Overhead Trolley Tracks and
Trolley Systems

Bulletin Free.

NORTHERN ENGINEERING WORKS, Detroit, Mich., U. S. A.
or, Canadian Dept., ADVANCE MACHINE WORKS, Ltd., Walkerville, Ont.

The advertiser would like to know where you saw his advertisement—tell him.

A Number of Interesting Railroad Shop Bending Devices

Each Operation, Jig or Bending Form is Illustrated and Described, so that Railroad Mechanical Men will at Once Understand the Tools and their Operation.

By Ethan Viall.

Nearly every railroad shop possesses a number of bending devices, besides the regular bulldozer forms. For the benefit of those who are not familiar with these tools, I shall describe a number of bending devices which I have seen in various shops within the last few years.



Fig. 1.—Making Car Footholds.

All of us have seen the footholds or steps on the sides of freight cars, but few, perhaps, have ever given a thought as to how they were made. Fig. 1 illustrates clearly how the bend and twist is made on the bulldozer, at one operation.

The bending arms A-A are made like

be out of place to describe here how it is done.

Instead of being done on a bulldozer, a forging machine, of the Ajax type, is used, the punches and dials being shown in Fig. 2. Three strokes of the machine are required for the forging of each end. The first stroke leaves the rod in the shape shown at A, the second stroke as at B, the punch marked B doing the work, and the third stroke the punch C pierces the hole in the end of rod C.



Fig. 3.—Final Bend of Car Foothold.

The final bending of the end is done in the cut-off of the machine, with the punch and die shown in Fig. 3.

Another bending operation which is done on the regular bulldozer is shown in Fig. 4. The bending arms are the same shape on the inside as the loop to be formed, a piece of heavy boiler plate being riveted to the top of them to prevent the ends of the loop lifting and being bent out of shape.

Fig. 5 is another interesting device for bending a special loop. After the



Fig. 4.—Bending Operation.

This cut shows the first bend completed and the ram drawn back ready for the second stroke, which is shown finished in Fig. 7.



Fig. 5.—Bending Special Loop.

An eye bolt former is shown in Fig. 8.

The bending is done by means of a rack H, which is fastened to the ram of

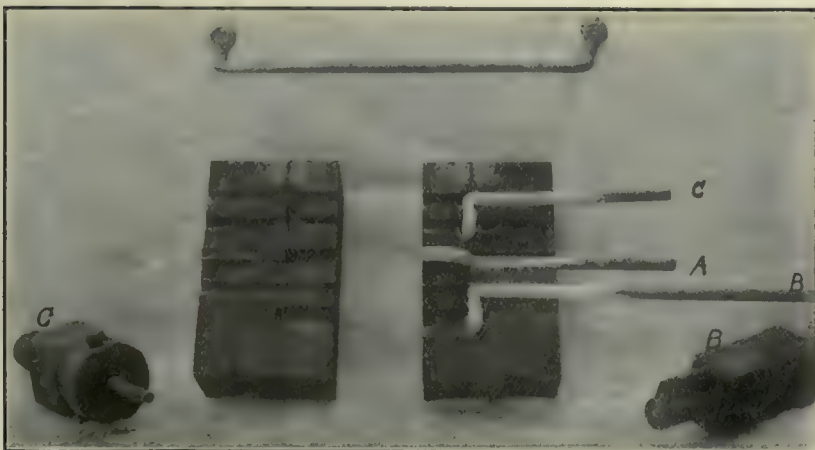

Fig. 2.—Handholds and Forms.

an inverted L on the half nearest the end, in order to give the twist. The curved guide B, is to keep the arms from lifting during the twisting operation.

While the making of the handholds, used on freight cars, is more of a forging, than a bending process, it will not

bend is made the forming punch is drawn back and the bent piece lifted off.

The forming of handles for pokers, slice bars and the like, is usually done on a pneumatic bulldozer in two strokes, the first operation being shown in Fig. 6.

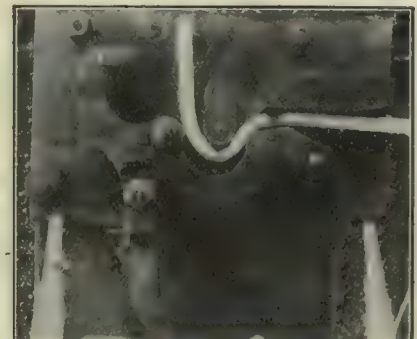

Fig. 6.—First Operation Bending Slice Bar Handle.

the bulldozer. As this rack moves forward it turns a small pinion fastened to the bottom of M, which causes the block

K to travel around, bending the end of the rod as it goes.

A quick way to bend small clevises, used on brake chains, is shown in Fig. 9.

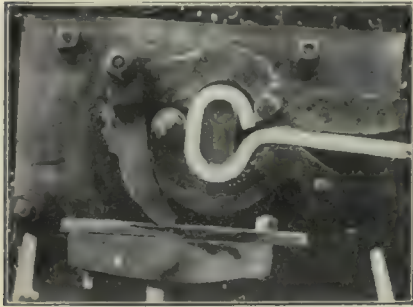

Fig. 7.—Complete Handle.

These clevises are first punched out of sheet metal in a punch press and then shoved through the loop as shown.

Some of the bent clevises are lying on the bed of the machine, at the left.

Practically the same thing in a stationary form is Fig. 11.

Fig. 12 is a portable rail bender, an eccentric at P giving the stroke, while the plunger is fed out by nut R, which has right and left threads.

Fig. 13 is a hand bender for forming



Fig. 9.—Bending Small Clevises.

S-links from iron rod up to 1/2 inch in diameter. Fig. 14 shows how it is used by setting the shank in the hardy hole of the anvil. The operator shown in this cut is Joseph Damm, blacksmith foreman of the Wabash R. R. shops.

blocks and is heavy enough to do all kinds of bending on.

An arbor press that is good for some kinds of bending as well as pressing mandrels in or out, is shown in Fig. 16.

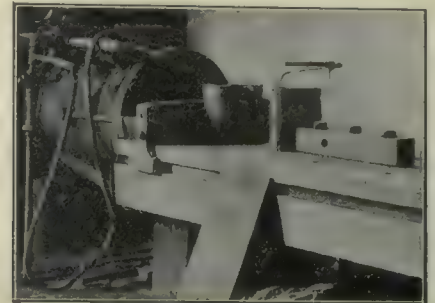

Fig. 11.—Homemade Stationary Bulldozer.

The sliding head is counterbalanced by a weight and rope, running over pulleys, fastened at B. Steel pins inserted in the holes in the sides prevent the head

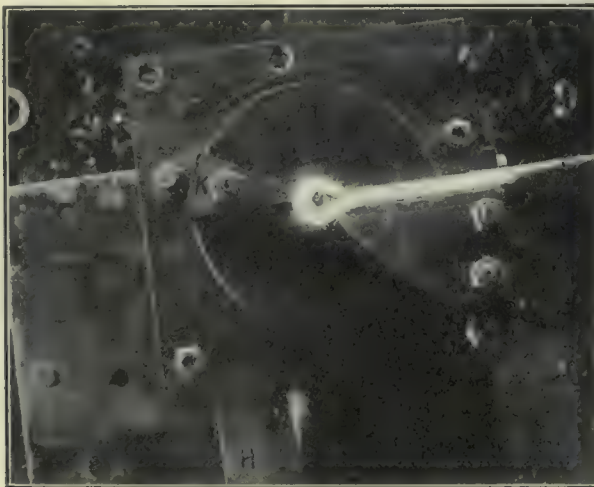

Fig. 8.—Eyeholt Former.

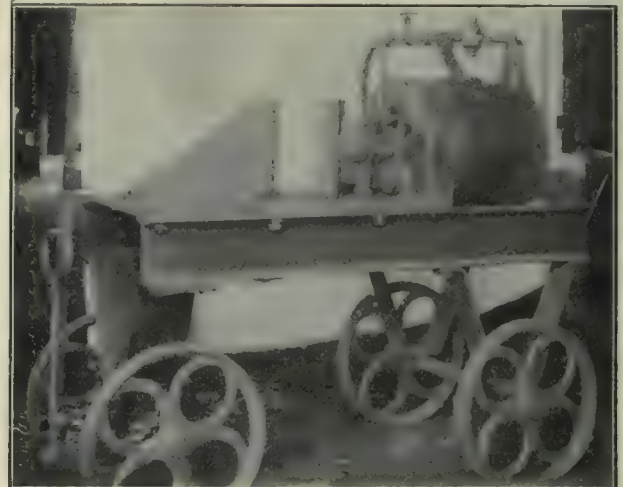

Fig. 10.—Portable Bulldozer.

One of the most convenient portable bulldozers, for bending angles or other forms, is shown in Fig. 10.

The whole affair is homemade and was built for hard usage.

Fig. 15 shows one of the best clamping anvils imaginable. It was made out of cast iron blocks and other scraps found around the shop, and may be used to hold swages, bending forms or die

rising under pressure. The lugs cast on the hand wheel allow the use of a long lever for heavy work. In order to prevent the frame of the press from being twisted out of shape on heavy work the



Fig. 12.—Portable Rail Bender.

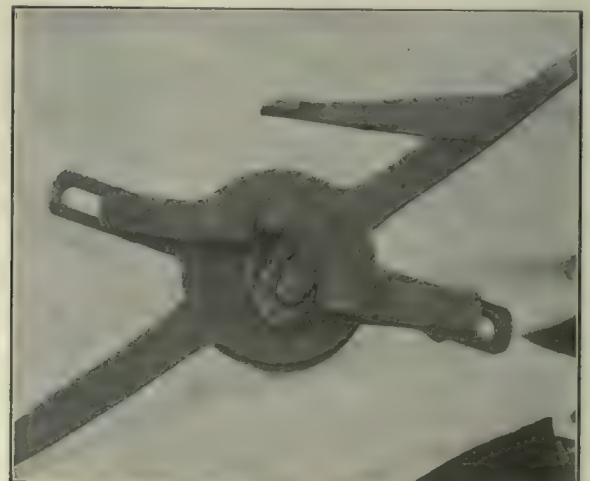

Fig. 13.—Hand Bender.

TOOLS AND FORMERS.*

By Arthur Stockall.**



Fig. 14.—Hand Bender in Use.

sides are braced at the top by heavy wooden beams. The cast iron V-form



Fig. 15.—Clamping Anvil.

is very handy for various jobs, and especially for mandrels.

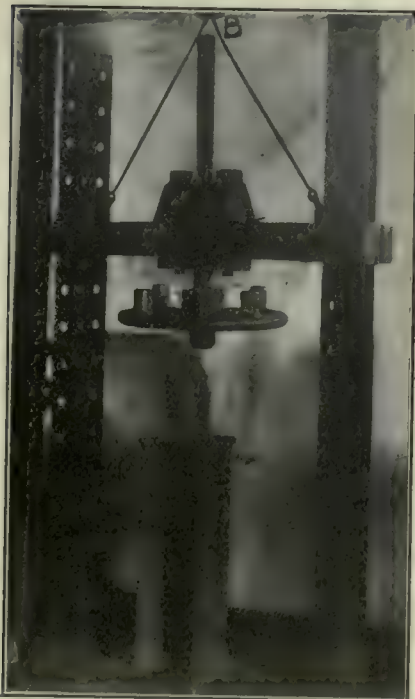

Fig. 16.—Arbor Press.

There is continually a demand for more economy in tools and speed in manufacturing, and this requires that tools and formers be constantly changed in shape so as to reduce breakage in material, cost of tools and time in making a given piece of work. Therefore, IN THE DESIGNING OF TOOLS THERE ARE THREE THINGS THAT SHOULD BE BORNE IN MIND: TO BE EASY ON MATERIAL, EASY ON TOOLS AND EASY TO HANDLE. IN THE CARRYING OUT OF THESE THINGS LIES THE TRUE SUCCESS IN HANDLING OUR WORK; for I think that it is better to have two simple tools to make one piece of work, than one complicated and expensive tool, with the danger of breaking the material in the end.

The formers for the bulldozer, I think, can be made cheaper and more conveniently with cast iron, reinforced with hardened steel at the places where friction will take place, so that instead of wearing out the casting, the steel will take the strain and when this is worn out it can be removed and a new piece put in. In other formers, or in fact wherever possible, the roller tool should be used as the best means to save material and power.

Then there is a tool that can be used to make a lot of work, such as freight car steps, carrier irons for passenger cars, glands and all such work where a double bend is required, or a good square corner is needed. I mean a tool with a hinge made so that it will move back far enough to allow the iron to be put in and far enough apart to let the ram come down to square up the crown or middle of the work, thus making a good clean square job that no one need be ashamed of.

As I said before, these tools may be made out of good clean castings reinforced with steel at wearing points and machined where necessary and by a little foresight they may be made so that one former, with a liner put in, can be used for different articles of almost the same shape, but of a different size; this will save cost of tools and cheapen production.

Use of High Speed Steel.

In all cases where cutting or punching hot material is required high speed self hardening steel is the stuff. It costs more to put it in, but does its work splendidly and it is a relief to the burdened foreman and a joy to the worker, with no more running water, no

more burning and peeling of die, or punch, or cutter, and consequent bending and breaking of tools with the machine on the hog half the time, with the toolmaker swearing and workman grumbling.

I well remember my own experience of four years ago in this line. I was punching a lot of steel follower plates. They were pretty hard and of course the usual trouble was intensified by this. If we used water to cool the tools, they split and broke, and the man wading in mud, grumbling and doing very little. I was about to give it up and fall back on the drill; but high speed steel came into my head, and off I started for the toolmaker and stated my case.

"I won't do it," he said; "it is only a waste of time and material."

"Let's try it, anyway," I said.

"I won't," he replied, and he would not, until I went to the master mechanic and got his doubtful consent, and at last the tools were made and put in, and the difficulty was gone. High speed steel is undoubtedly the stuff for this kind of work and pays 100 p.c. every time.

I used to think that mild steel was good enough for bolt headings, etc., and I tried it thoroughly, but it was not satisfactory. It would burn up in spite of all I could do. "Caseharden it," said my bolt maker. This I did, with the result that almost always the block would warp or bulge out in the middle and in grinding this out the casehardening would be all gone and my labor went for nothing. Then I heard a man say cast iron chills are fine, and cheap. I tried this and found that the blocks would chip and split in two. Chilled tools in my opinion are a waste of time; but I consider good clean cast iron tools superior to any of the other above mentioned for durability and economy. They can be put in and used with a little grinding and when used up can be sold for scrap for more than scrap soft steel. But, I think, from my experience, that self hardening or a good water tempering steel is best for this work. It costs more, but lasts longer and does better work while it does last, and for machine forgings of all sorts a good hard, tough cast steel is best.

For steam hammer tools nothing is too good. You can make an endless variety of things under them and a good material for these tools is the question. A dense grained cast steel top and bottom of about .30 carbon; for wedges a good hard soft steel is the best; for forming blocks, cast iron with a wrought iron band around it to keep it from splitting, gives a tool that will make almost anything.

* Read before Master Blacksmith's Association, Chicago.

** Foreman forge shop, I.C.R. shops, Moncton, N. B.

Keeping the Toronto Street Railway Cars in Service

Many Useful Devices are in Use which Facilitates the Work and Reduces to a Minimum the Time a Car is in the Shop for Repairs.

By Gordon C. Keith.

QUICK repair and economy are two watchwords in the shops of the Toronto Railway Co., Toronto. Many devices are in use to hasten repairs and keep the cars in service. Economical methods are followed to keep the cost of repairs down to a minimum.

Fig. 1 shows a jig for boring armature bearings. The jig has a screw (E)

types of trucks. The jig is shown by drawing in Fig. 2. In drilling the hanger, the undrilled hanger is first drilled on one end. It is then placed in the jig and the pin inserted in the hole, depending on the length required, as shown in Fig. 3. The set-screw adjusts the brake shoe hanger so that it takes the proper position when inserted in the jig.

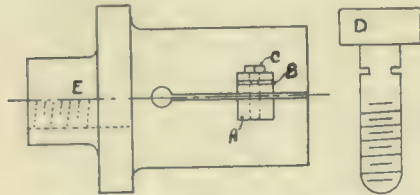

Fig. 1.—Jig for Armature Bearing.

in one end to fit the headstock of a lathe. A is a lug, one being as shown, and a solid one on the opposite side to balance it. The jig is split on one side, the split being opened up by a piece of sheet steel to remove bearing easily. C is the bolt to lock jig. It is shown enlarged at D. B is a slot in the lug for locking the

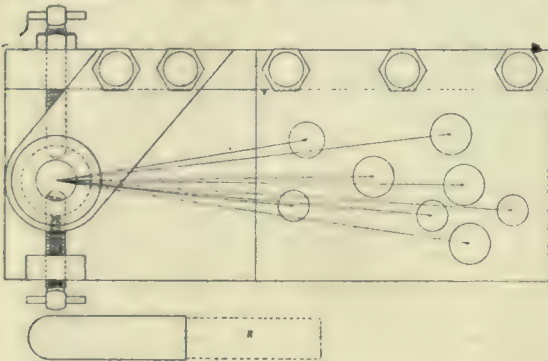

Fig. 2.—Details of Brake Shoe Jig.

bolt, keeping the bolt from working out of the jig and thus holding the bearing securely during the boring operation on the lathe.

Drilling Brake Shoe Hangers.

The jig for drilling broke shoe hangers will accommodate eight different

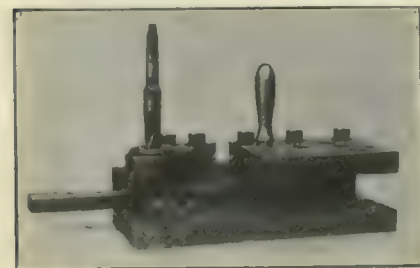

Fig. 3.—Brake Shoe Hanger Jig Complete.



Fig. 4.—Details of Brake Shoe Jig.

The drill is guided by the steel bushing B, Fig. 2, and there are three different sizes to suit the shoes for various trucks. Fig 4 shows the details of the jig with a brake shoe hanger. With this jig there are no short and long hangers, all being standard length.

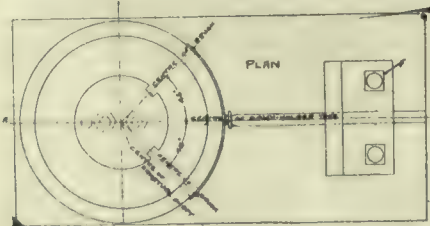
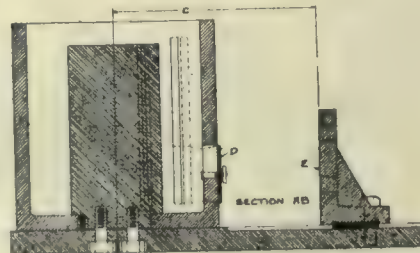
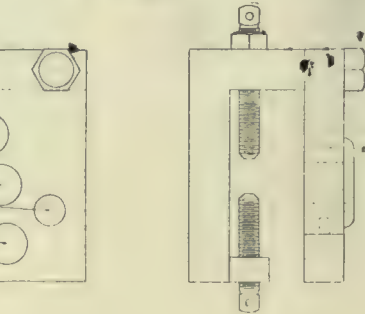

Fig. 5.—Adjusting Brush Holder of the Yoke Type.

Brush Holder Gauge.

Fig. 5 shows a gauge for adjusting brush holders of the yoke type. To the metal bedplate is bolted a cylinder, the



Fig. 6.—Side View of Gauge with Dummy Carbon.

same size as the average commutator. In the centre is a steel post about 4 ins. in diameter. It will be noted in the illustrations Fig. 5, 6 and 7, that the centre post is slotted to receive a steel dummy carbon brush, the cylinder also being slotted to allow the passage of the steel plate.

A section through the jig at AB, Fig. 5, is shown. C is the distance from centre of shaft to brush-holder base. D is guide to make carbon meet commutation square. E is an adjustable bracket bolted to the bedplate, to make allowance for the difference between centres of the different types of motors.

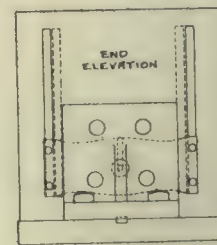

The complete brush-holder is bolted to the adjustable bracket, Fig. 7, and if correct, the dummy will pass through the carbon-holder cylinder, and pass into the slot in the centre post. The brushes are set at 45 degrees to the centre line. At F, in Fig. 5, the holes are drilled and tapped in base to suit different types, as previously mentioned, in regard to F. G is the brush templet, made the same section as the brush, but long enough to

reach through brush-holder, through the cylinder and into the inside slot, as explained above.

Protecting Machinery.

The protection of the workmen from accidents is important in keeping the staff of workmen complete. The machinery, such as drills and planers, which have open belts, are protected by an iron



Fig. 7.—Jig Complete Showing Dummy Carbons in Place. A Dummy Carbon is in Foreground.

fence. Fig 7 shows the protection around the belts and pulleys of a drill.

Machining Car Wheels.

The machining of car wheels is very important, and the master mechanic, W.



Fig. 8.—Protecting Workmen from Injury.

R. McCrea, and his foremen are kept in close touch with the work. The wheels must be pressed on the axles at a cer-

tain tonnage. Records are kept of the mechanic who has charge of the boring of each wheel and who presses them on the axle. If a wheel slips, the record shows who machined them. As each wheel is numbered, the keeping of the records is a simple matter.

When a car is in service some of the

in Fig. 10. The other side corresponds to the one shown. By means of the handle A, the rest B to which the wheel is attached is moved backward and forward similar to the tool rest of a lathe. By means of the wheel C the bracket D is raised or lowered, adjusting the grinder to the car wheel.

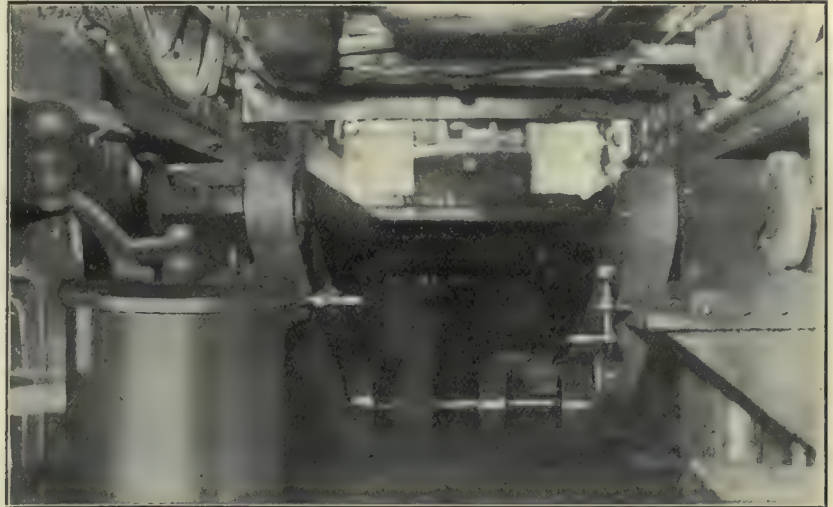

Fig. 9.—Arrangement for Grinding Flats from Wheels.

wheels often develop flats. These are removed by grinding. For this operation the arrangement of motor, shaft and grinders shown in Fig. 9 has been devised. An ordinary starting box is used for turning on the power when the wheels are lowered into position. The

Tool Room.

The tools are all in charge of one man, who is an expert tool grinder. As each tool is given out, the workman presents a brass check on which is his number. The check is hung in the place occupied by the tool and the mechanic is held responsible for its safe return. The grinding is done on a Yankee Tool Grinder



Fig. 10.—Details of Wheel Grinding Machine.

portion of the track on which the truck shown in the illustration is removable allowing the wheels to be lowered to the grinder.

Details of the arrangement are shown



Fig. 11.—Babbitt Furnace.

made by Wilmarth & Norman, Grand Rapids, Mich. The man in the tool room keeps all tools sharpened.

In the tool room are standard samples of all small pieces. These, also, are given out to workmen on presentation of check and the employe is held re-

sponsible for any sample he secures from the tool room.

Homemade dies are made to run over the thread on the end of armatures. This removes any bur without putting it into a lathe.

Melting Babbitt.

The babbitt for armature and axle bearings is melted in the pots shown in

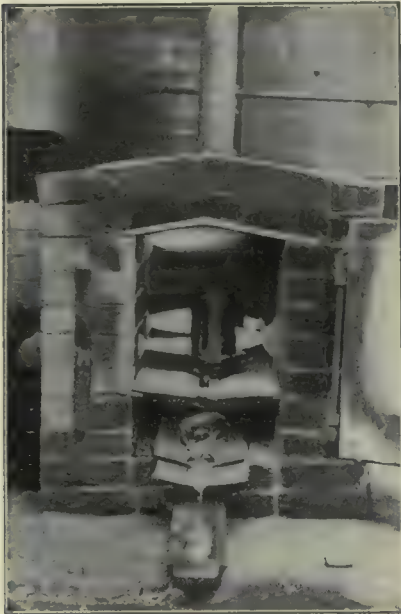

Fig. 12.—Melting Babbitt from Bearing.

Fig. 11. At X is a McCabe nozzle invented by Mr. McCabe, an employe of the Toronto Street Railway Co. Gas and air are blown through a small orifice and a very hot flame is produced, melting the babbitt in about half the time usually required.

At the right of Fig. 11 is shown the furnace in which babbitt is removed from bearings. A hood covering pots



Fig. 13.—Car Cleaning Outfit.



Fig. 14.—Painting Car Fenders.

and furnace carry away all fumes. Fig. 12 shows the interior of the melting

from armature bearings is used for axle bearings. When babbitt is melted from axle bearings it is scrapped. This is analyzed and is brought up to original form. The oven is built of firebrick. As the



Fig. 15.—Thermit Welding.

furnace. There are four burners below and one above. The babbitt melted

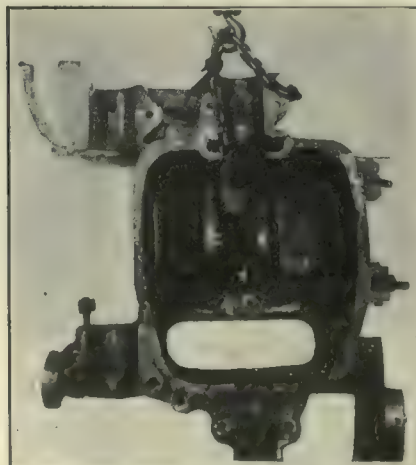

Fig. 16.—Casting Showing Weld.



Fig. 17.—Armature Repairing Stand.

firebrick melts it runs into an ingot mold. The oven is also used for soldering brass axles together, this method being much quicker than by the charcoal fire.

McCabe Cleaning System.

The Toronto Street Railway Co. uses the McCabe combined compressed air and vacuum system of cleaning. The

coupled on the same bedplate. The compressor is installed on a small car, arranged to run on the street railway system, and fitted with the necessary

Painting Car Fenders.

Car fenders are painted by means of an atomizer. The paint is blown on by compressed air; the surplus paint dripping into a paint vat below. The arrangement is shown in Fig. 14. All paint vats are covered when not in use as a precaution against fire.

Thermit Welding.

The thermit system of cast iron welding is used by the street railway company, the welding being carried on under the supervision of the master mechanic. Fig 15 shows the thermit iron running into the mold while Fig. 16 shows the repaired case.

For welding the casting is set in position in a one-piece mold, the casting being packed around with green sand and fire, provision being made for a supply of metal around the broken part, riser, etc. The heat of the thermit reaction is approximately 5400 degrees F.

Electrical Department.

Many interesting methods are used by the Toronto Street Railway Co. to make repairs to motors as quickly as possible. Fig. 17 shows a unique manner of re-

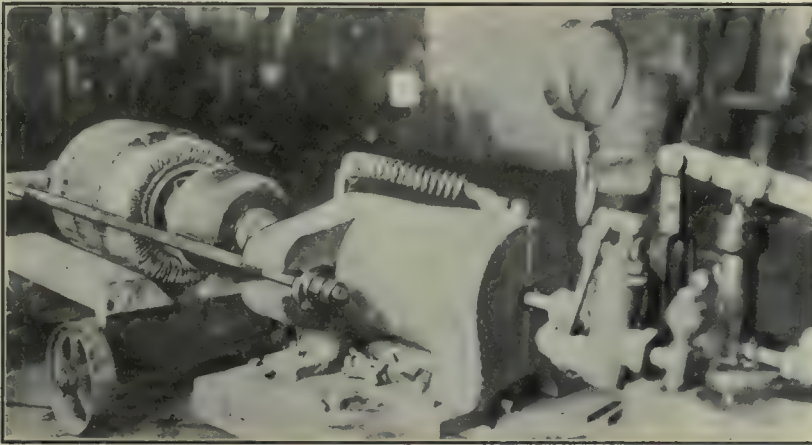

Fig. 18.—Hydraulic Press for Commutator.

air compressor is a Reavell's single stage, water-jacketed type, installed by Vandeleur & Nichols, Toronto. It is de-

signed to deliver 60 ft. free air per minute and a pressure up to 100 lbs.

electrical equipment and air receiver as shown in Fig. 13. The McCabe cleaning apparatus consists of a short pipe in which a nozzle is fixed so that it points (parallel with the

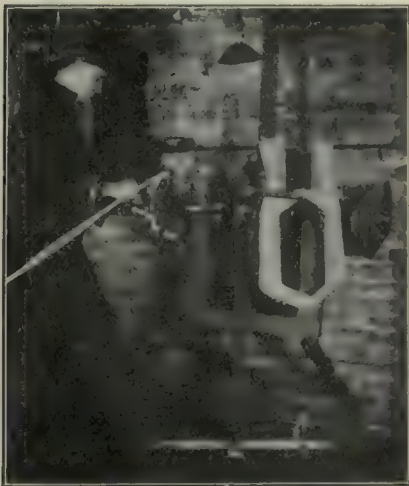

Fig. 19.—Core Winding Machine.

signed to deliver 60 ft. free air per minute and a pressure up to 100 lbs.

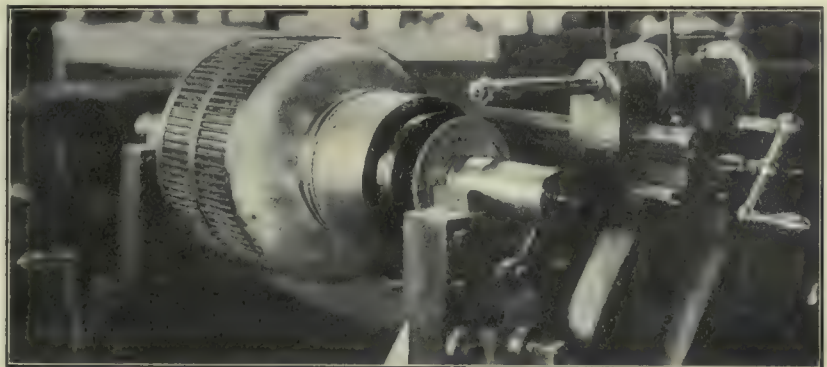

Fig. 21.—Mica Slotting Machine.

pipe) towards the discharge end. The nozzle is connected to the compressed air. The compressed air discharging out of the nozzle into the pipe, drives the air into the pipe towards the dis-

charge end, creating a vacuum at the inlet, thus causing a current of air to enter at the inlet end and pass out at the discharge end. This mechanism is known as the vacuum machine.

pairing armatures. A cast iron stand is fastened to the floor by coach screws. The armature is then stood up perpendicularly for repairing as shown in the illustration.

A hydraulic press for putting commutators on and off is shown in Fig. 18. The press is worked by hand. The illustration shows the armature in position with side rods on the hydraulic press. Fig. 19 shows a core winding machine. The man is in position for winding the cores and three are made at once. The machine is equipped with a foot brake.

The arrangement shown in Fig. 20 is a lathe attachment for slotting armatures for wire connections. The machine shown in Fig. 21 is a mica slotting machine. Since taking the photograph a further improvement has been made. Instead of milling out the slots, a cutter has been substituted and the belt done away with. By means of a lever and eccentric a groove is cut at

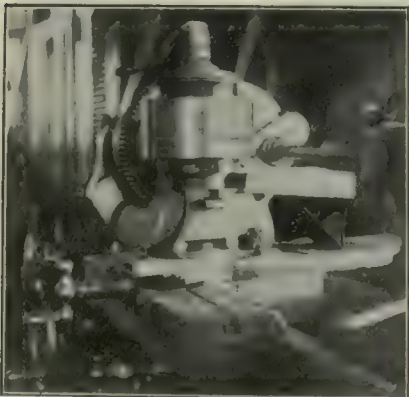

Fig. 20.—Slotting Commutator for Wire Connections.

per square in. It is driven through rawhide gearing by a Laurence Scott motor,



Fig. 22.—Taping Machine.

charge end, creating a vacuum at the inlet, thus causing a current of air to enter at the inlet end and pass out at the discharge end. This mechanism is known as the vacuum machine.

By means of a lever and eccentric a groove is cut at

one stroke. The cutter is adjustable to any size armature. The improved machine is much more efficient than the one run by the belt.

Fig. 22 shows one of the tapeing machines in operation. The machine



Fig. 23.—Small Air Presses and Tapeing Machines.

operates in the direction of the arrow, the tape being fed from the small wheel at the side. The tape is put on smoothly and quietly.

The small air presses are shown in the foreground of Fig. 23. By means of these paper is put on the coils with hot glue. Two of tapeing machines are in operation, the countershaft for them being underneath the table.

The field coils are tested by the press shown in Fig. 24 under a pressure of 5 tons. A coil is shown in position. The ram has iron wings which presses down the coil, and if there are any loose wires they will short circuit under the pressure.

wire cloth and screens have been greatly simplified and improved by them.

A recent improvement has been the addition of the large wire cloth rolls shown in the illustration. While wire cloth has the advantage over perforat-

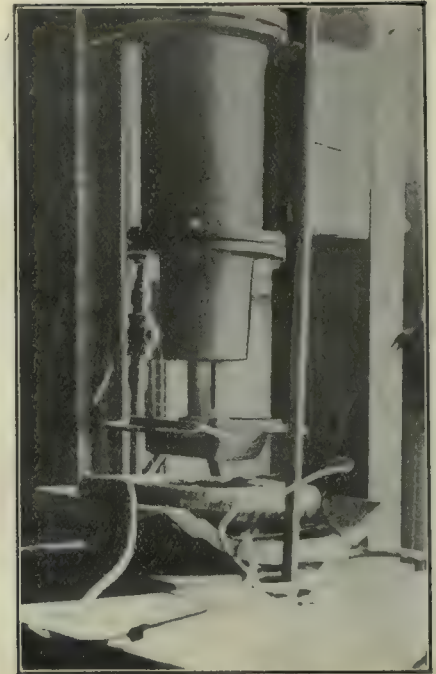

Fig. 24.—Field Coil Press.

ed metal for sieving purposes, in many cases the rough or uneven surface of the former has been a great disadvantage. This has been overcome by passing the cloth between heavy rolls to flatten the crowns of the wire. The B. Greening Wire Co. have always done a large amount of this work, and lately, finding the demand for same very largely increased, they installed rolls to take care of the demand for medium weight screens. This proved such a success that the firm were encouraged to put in heavier rolls. These rolls are now in-

stalled, and are probably the heaviest rolls to be found in any wire cloth plant on the continent.

The installation of these rolls shown in the illustration marks the completion of a wire weaving plant that is equal to that of any concern in the world making the same class of work.

WIRE CLOTH ROLLS.

The B. Greening Wire Co., Hamilton, have been steadily improving their plant and equipment. New machines have been installed from time to time and the processes of manufacturing

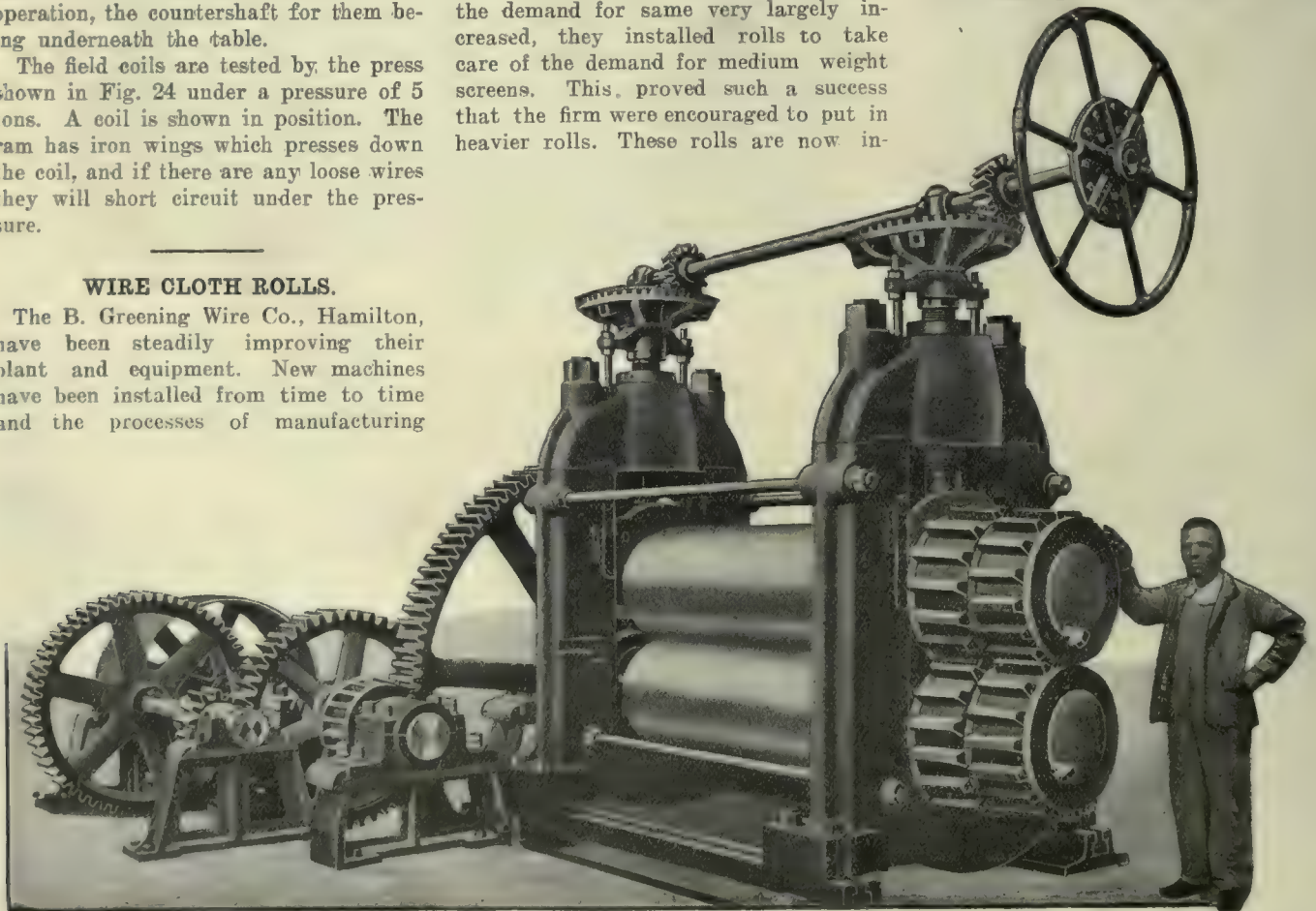

Heavy Wire Cloth Rolls Installed by the B. Greening Wire Co., Hamilton.

Devices Employed in a Small Railway Repair Shop

Some Ways and Means of Handling Work, as used in the Pere Marquette Shop, St. Thomas, which is a Small Place with limited Labor-Saving Equipment.

By Fred H. Moody, B.A.Sc.

The machine shop, devoted exclusively to repair work, has probably reached its highest stage of development in the railway world, for from the very rough usage afforded locomotives and rolling stock in general, they are constantly un-

dergoing more or less extensive repairs. It is for that reason, that in many cases these railway repair shops have reached the very highest stage of machine shop

one of the many shops throughout Canada. The Pere Marquette shops at St. Thomas afford an excellent example of the foregoing, as here rolling stock for both the Pere Marquette and Wabash

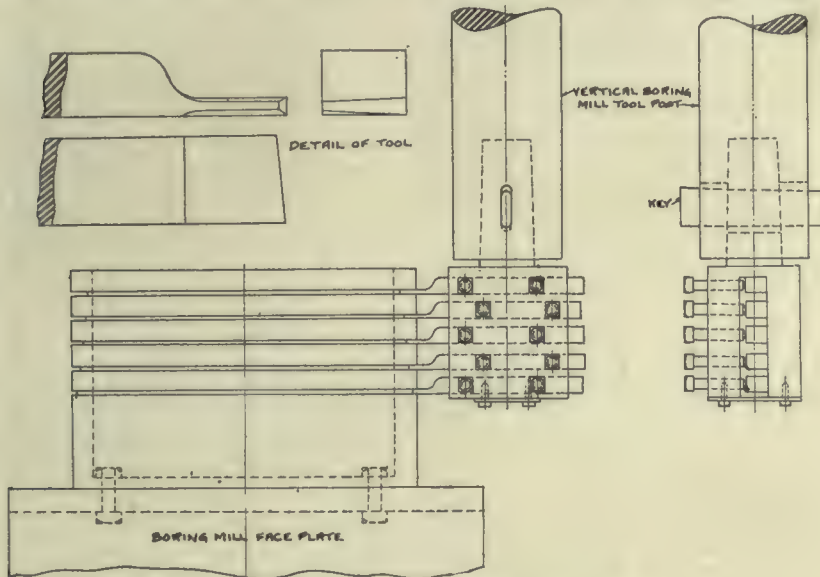

Fig. 1.—Cook Lang Tool for Cutting Piston Rings.

dergoing more or less extensive repairs. It is for that reason, that in many cases these railway repair shops have reached the very highest stage of machine shop

Railroads, is repaired. In addition, as both these lines do not do a very extensive Canadian business, the rolling stock is not as great as on many other of our

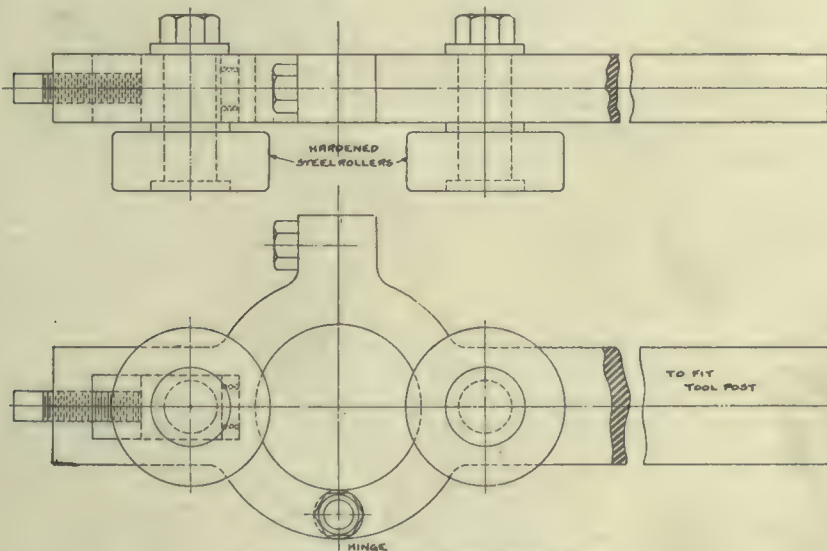

Fig. 2.—Tool for Rolling Piston Rods.

development. However, even though the very latest and most up-to-date appliances be introduced, from the very great variety of work to be handled, in making difficult repairs, each shop seems to have risen to the occasion and developed its own line of special appliances. This may be readily verified by a trip though any

lines, with the result that the shops are of only medium size. This fact makes it all the more essential that many devices be improvised to do the work. These conditions have been well met in these shops, of which Mr. Montgomery is master mechanic, and Mr. Griffiths general foreman.

Machine Shop.

This department is well equipped to meet most exigencies; yet, several neat little schemes have been devised and put into use by the foreman, S. W. Cook. Chief among these is a gang tool for finishing up piston rings expeditiously. This is shown in Fig. 1. In design, it is very simple, consisting of a fixture to be attached to the vertical boring mill tool post by a taper shank held in place by a

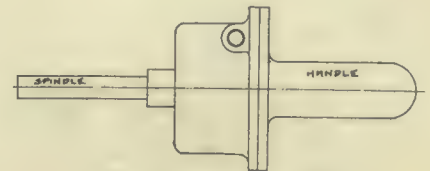

Fig. 3.—Small Air Drill.

key and therefore readily removable. From a close examination of its construction, a large variety of sizes may be handled, as the tools may be shifted as desired to give the proper width of ring. The strain of the set screws on the tools is taken up by a plate shown at the bottom of the tool. The stock piece requires no comment being of the usual type. It will be noticed that the tools are set, each one slightly back of the one above, so that while the operating cuts are simultaneous, the rings are separated one after the other. Several

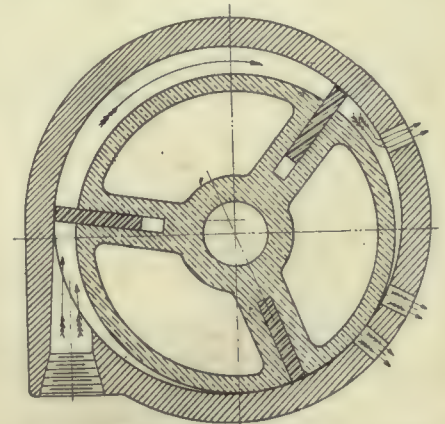

Fig. 4.—Cross Sectional View of Small Air Drill.

of these tools are in use in Detroit where it was first devised.

Fig. 2 shows a tool, which, while not new in principle, is yet new in its application. It is used for putting a finish on piston rods, after the lathe tool has done its work. As shown, it consists of two hardened steel rollers on an arm which may be attached in the tool post of any lathe. The outer part of the holder is hinged as shown, so that this

portion may be swung back and the tool placed around the piston rod in the lathe. The holder is adjusted perpendicularly to the rod, and shoved up to the shaft until the right hand roller is pressing it, and then the left hand one is tightened on the rod by the set screw shown, the whole tool being first made rigid by tightening up the hinged portion. The rod receives a mirror finish, at the same time in no way interfering with the accuracy of the previous machine work. The same type of tool, with but one roller, is used extensively

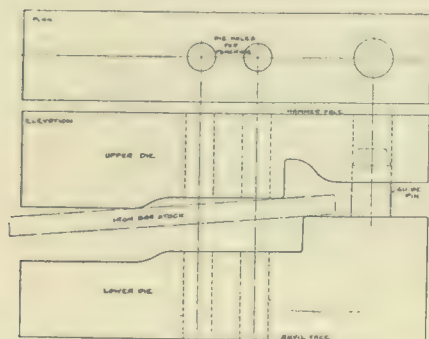

Fig. 5.—Forging the Ends of a Car Coupler Pocket.

in railway shops for finishing coach wheel journals, and similar bearings, as the surface produced is perfect.

C. Trumper, the toolmaker, has made a very neat little air drill which has been found very useful for drilling small holes. This is shown in Fig. 3, and the construction clearly shown in the cross-sectional view, Fig. 4. It operates on the same principle as that used in several recent attempts at producing a high speed rotary steam engine. The shaft is placed eccentrically leaving a space on one side. Air impinges against protruding steel blades in the brass rotor, causing it to revolve at an extremely high

the air escapes at nearly full pressure, but little allowance being made for expansion. It answers all requirements, which in this case is a more important factor than thermodynamic considerations.

As usual in such shops, there are the usual cylinder boring and crank pin turning attachment for refinishing the cylinder and crank pin without using a boring mill or lathe. The crank pin turning device is one improvised in the shops, for their own services, and is driven as usual through a train of gears, from a motor.

The Pere Marquette and Wabash use different types of babbitt piston rod packing rings, the former being made in one piece, while the latter is formed from three specially shaped pieces. These pieces, two of which are similar, are roughly made in a simple little device, an opening die, very easily operated by two levers, around a pin, slightly smaller than the piston rod. They are afterward machined to requirements.

It is customary in making thrust bearings for the locomotive drivers, to first recess the driver hub, and fit in a brass collar, made in two sections, to be placed over the shaft, and then rivet in place, and finish the face. This involves finishing both driver hub, inner face of bearing, and finally the outer face of the latter when completed. Here a different method is employed, saving much of the machine work. The axle with drivers is placed on end and an old piston ring slightly larger than the desired bearing placed loosely around the axle. The hub has previously been roughed out. A small blast furnace holding a small pot, melts sufficient brass for all requirements. This brass is poured into the recess in the hub, and flows out in the vessel formed by the rings. When hardened, the drivers are reversed, and the other end treated similarly, after which the rough brass is finished as required. This process obviates much of the machining otherwise required.

Blacksmith Shop.

Much ingenuity has been required on the part of Mr. Tanner, foreman blacksmith, for the equipment is very limited. Probably the most missed machine, is a bulldozer. The steam hammer, however, has been made to take its place very well, though with nothing like the same rapidity of production. This latter feature is not the important factor in a repair shop.

speed. The air exhausts as shown. The centrifugal force of the revolving blades, keeps them out, requiring no springs for that purpose. While, as previously mentioned, it produces considerable power, it is by no means an economical device, as

the ends bent in. A bulldozer would crimp, punch and bend the stock, one operation for each end, and then in a third operation, would double into the U shape. A somewhat similar set of dies is here used, the first set shown in Fig. 5. The stock of the requisite length, has the end heated, and placed on the lower die as shown. On top of this is placed the upper die, guided by the guide pin, and in a couple of blows

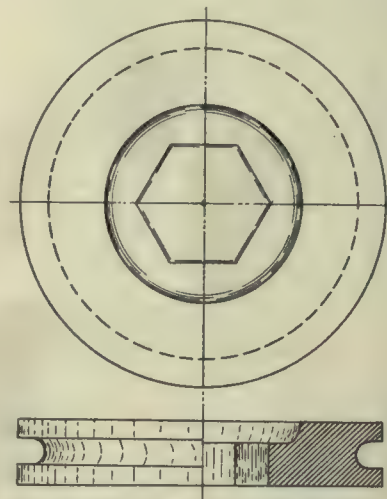

Fig. 7.—Forge Die for Crank Pin Nut.

of the hammer on top of the upper die the end is forged. Pins are next placed in the holes shown, and the bolt holes in the coupler punched through. This operation is repeated for the other end. A similar procedure is employed to bend the ends into the U shape, as shown in Fig. 6. The hammer strikes the upper die, forcing the strap down into the lower die. Careful adjustment is necessitated, as otherwise the ends would be uneven.

The absence of a drop hammer is not seriously felt, as a series of dies, somewhat similar to that in Fig. 7 are used. An ingot of iron or steel as desired, is placed in the die, and hammered under the steam hammer, to

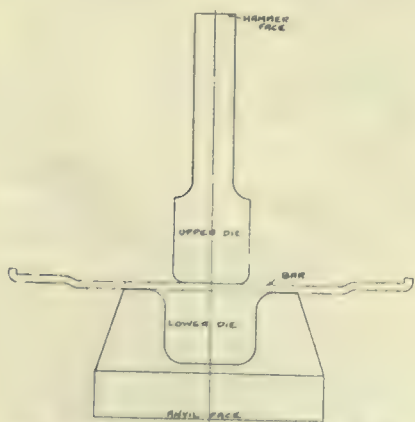

Fig. 6.—Car Coupler Pocket Being Bent.

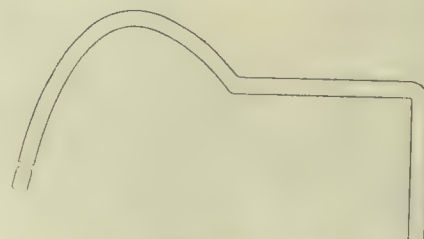

Fig. 8.—Flanging Die.

fill the die. A large variety of drop forge work is done in this way.

It is customary when flanging boiler plates, in the ordinary shop, to use cast iron dies, of the correct curve on which to do the flanging. This process is used at the Pere Marquette shops, and a large variety of dies carried in

stock, but it has been found, that for repair work, to meet all requirements, more dies than they carry would be necessitated. Fig. 8 shows the P. M. method of obviating this difficulty. A $2\frac{1}{2}'' \times 3\frac{1}{4}''$ steel bar is bent to a shape, much the same as that shown, the left end forming a series of curves of gradually increasing diameters, on the principle of the French curve used by draftsmen. This has proved a useful acquisition.

The most characteristic feature of the blacksmith shop, showing their ability to improve on conditions, is the method employed for handling frames while forging. Customarily, one crane is used, the frame revolving on a ring in a looped chain from the crane, while the lighter end of the frame is balanced with the heavier by attaching a lot of heavy weights, an inconvenient, and cumbersome operation. In the handling of the frame a small gang of men

is required. At these shops two swing cranes are made use of, the frame being slung as before described near either end. These cranes are so placed that the frame may be swung from the fire directly under the hammer, requiring a minimum of help for its manipulation. This feature has proved an inestimable boom for facilitating frame repairs.

Boiler tube repairs are made in a manner similar to that employed elsewhere.

In conclusion, the St. Thomas shops afford an excellent example of what can be done in quite a small shop. It shows how ingenuity can be used to cope with the various exigencies that arise from time to time. The expeditious manner in which the work can be handled is remarkable when it is considered that the shops only have a capacity for handling six locomotives, which is considered quite a small shop.

Joint Meeting of British Institute and the A.S.M.E.

Subjects Discussed by Mechanical Engineers of Great Britain and American Society of Mechanical Engineers at Birmingham and London.

THE Mechanical Engineers of Great Britain and the American Society of Mechanical Engineers held a joint meeting at Birmingham and London, at which a number of important subjects were treated. Two professional sessions were held at Birmingham, the first of interest to railroad men, the second to machine shop men. The third session held in London was devoted to the electrification of railroads. About 700 were in attendance at the convention and besides the professional sessions, these enjoyed trips to points of interest and to the various manufacturing plants in the vicinity of the meetings.

The first paper was on "English Running Shed Practice," by Cecil W. Paget, Derby, England. Running shed is the British term for Round House. Running Sheds in England are two types, those in which the tracks are parallel and those in which the tracks radiate from a turntable. Mr. Paget described the modern type of shear legs, used to lift a locomotive while removing its wheels. Other features described are the system of keeping stock and supplies, lighting, arrangements for washing out, methods of coaling, ash pits and water softening equipment. The account of running shed arrangements comprehensively covers inspections of locomotives and their parts, running repairs, washing out of boilers, reports on engine failures, cleaning, system in passing engines through the repair shops and assigning them to their drivers, and the study of the results from statistics of the work of the various sheds. This system is that practiced by

the Midland Railway, of which the author is the general superintendent.

Engine House Practice

F. H. Clark, Chicago, gave a paper on "The Handling of Locomotives at Terminals to Secure Continuous Operation." It refers to such features of design and equipment as are considered good practice in the United States. A typical engine house is illustrated and described, and different types of coaling stations, sand drying apparatus, water tanks, ash pits and turntables. In contradistinction to English practice, instead of shear legs to raise a locomotive while removing its wheels, it is the custom in the United States to provide drop pits by means of which wheels may be removed and replaced without jacking up the engine. Other details of the engine house construction and appointments are elaborated upon, including the building itself, the pits, heating and lighting, tool equipment, storage of materials for repairs, oil, &c., and means for washing boilers, etc.

Papers on handling locomotives at terminals were given by Frederic M. Whyte, New York, and William Forsyth, Chicago.

Handling Engines

By H. H. Vaughan, Montreal.

This paper discusses particularly the practice of pooling engines. As to whether it is desirable or not depends, in the author's opinion, on whether the engines are engaged in passenger or freight service, and in the latter case on the conditions which exist. He proceeds then to take up these two kinds

of service separately, and concludes that in passenger service pooling is objectionable under any conditions, and should be avoided if possible, and that in freight service pooling is advisable if conditions are such that engines cannot be run with assigned crews, and probably on divisions where business is so heavy that 60 engines per day or over are dispatched from the terminal. Where assigned crews can be used on engines the cost of repairs, the amount of fuel consumed and the class of service obtained will all be more satisfactory.

Second Session.

The second session was of interest to machine shop men. An abstract of the papers is here given:

High Speed Tools and Machines to Fit Them.

By H. I. Brackenbury, Newcastle-on-Tyne, England.

After briefly reviewing the history of high speed steel tools and the gradual extension of their use in the 10 years since they were first introduced, the author defines the properties that make it useful and the three general classes in which such steels may be divided:

- A, for cutting mild and medium steel.
- B, for cutting hard steel.
- C, for cutting very hard steel and for use where a sharp and lasting cutting edge is required.

With regard to the power required to remove material, it has been found that more is required for a thin wide chip than for one of double the thickness and half the width, and at high speeds less power is required than at low speeds up to a certain point. It is difficult to lay down rules for cutting speeds, as conditions are so variable and it may be more important to preserve the edge and avoid frequent sharpening than to use the highest allowable speed. The proper cutting angle for a tool is the sharpest which will not break at the edge, as the sharper it is the less power is required. As high speed steel has improved, it has been found possible to make the cutting angle more acute.

On turret lathes the highest class of high speed steel is now being used and in tools with a very sharp cutting angle. In twist drills the steel has been found particularly valuable, increasing the amount of work done in a given time three-fold as compared with tempered steel drills and reducing the frequency of grinding. Generally speaking, full advantage is not taken of the cutting powers of high speed steel.

The author advocates setting aside certain machines for roughing only. Usually old machines have enough power for finishing, and increasing their belt speed, so that they may be run with the back gear in, makes them efficient. Regarding considerations affecting the fitness of machines for the use of high speed steel, it is pointed out that more is involved than the mere ability to remove a large amount of metal in a short time, if such a demand upon it is infrequent, as such a machine is expensive for use on light work and when idle. A machine should be selected with reference of the kind of work it will have to do most of the time.

Objections to cone driven machines are mentioned, and the greater desirability of geared speed changes or var-

iable speed motor drive; also the necessity of accurately cut gears and amply strong feed mechanism. The paper concludes with a summation of the characteristics which should be possessed by machine tools using high speed steel, including roughing lathes, turret lathes, slotting machines, radial drills, milling machines and planers, and is supplemented with tables of data on high speed twist drills, turning tools, milling cutters, etc.

Discussion.

Charles Wicksteed, Kettering, England, agreed with a statement made in the paper that it is a pity more use has not been made of the arrangement fitted to the planers designed by Sir Joseph Whitworth for cutting on both strokes, and referred at greater length to the reversible tool holder, which does away with an idle stroke. Double cutting, he stated, has had a slow growth, but has certain advantages that will mean its more extended use. One use of two tools is to have the leading one cut through the scale, so that the following one enters clean metal. The situation is reversed on the return stroke. The cut is, therefore, divided between two tools. He thought that users of motor driven machine tools will come to realize the cost of power and see the desirability of eliminating an idle stroke. Still he granted the sufficiency in many kinds of work

of a planer with quick return motion; for example, where the time of setting tools for double cutting would be a loss of advantage. Both quick return and double stroke have their field of usefulness, and he was pleased that the author had called attention to the advantages of double cutting.

William Lodge, Cincinnati, Ohio, emphasized the fact that high speed in the tool equipment is not the only consideration. How to get the best results from the workmen, route the work through the shop, and kindred provisions for increasing output are equally important. He spoke further of the need of greater attention to system in manufacturing.

The discussion was followed by a paper on "Tooth Gearing," by A. B. Steven, Birmingham, England, and one on "Interchangeable Involute Gearing," by Wilfred Lewis, Philadelphia, Pa.

At the London meeting papers were read by F. W. Carter, Rugby, Eng., on the "Electrification of Suburban Railways;" by H. M. Hobart, London, on "The Cost of Electrically Propelled Suburban Trains;" by W. B. Potter, Schenectady, on "The Economies of Railway Electrification;" by L. H. Pomeroy, New York, on "The Electrification of Trunk Lines," and a paper by George Westinghouse, Pittsburg, on "The Electrification of Railways."

ing out a patent in the Dominion, would automatically secure protection of his invention for twelve months in all other subscribing countries without extra charge. Your committee, with the concurrence of the Council, recommend to the Government that steps be taken to bring Canada into the convention. Thus far, however, nothing seems to have been done.

The subject of Canada's Patent Regulations was fully discussed in the July issue of Canadian Machinery.

Technical Education.

The report of the Technical Educational Committee contained the following:—"After six long years of careful planning, persistent effort and constant agitation, all directed toward the one end, it affords your Technical Committee satisfaction to be able to report that the special task assigned them by the Montreal convention of 1904 has at length been accomplished. The committee urged on behalf of the association the immediate appointment by the Dominion Government of a commission of inquiry, with instructions first to ascertain the actual needs of the Dominion in the way of technical education and industrial training, and then to see how those needs could best be met by adapting to Canadian conditions the facilities provided in other countries. In March last the Government made public announcement of its intention to appoint the commission so earnestly desired. About the middle of July the commissioners began their work in the Maritime Provinces, and your committee are informed that it is their intention to cover Canada from the Atlantic to the Pacific. While it is the intention of your committee to prepare for the consideration of the commission a general statement on behalf of the manufacturers of Canada, they wish to take this opportunity of urging every member of the association to facilitate the inquiry to the best of his ability."

The following officers were elected for 1910-1911.

President, W. H. Rowley, Hull, Que.

Vice-President, Nathaniel Curry, Montreal.

Provincial Vice-Presidents, T. B. Rogers, B.C.; S. N. Dougal, Que.; J. P. Edwards, N.S.; T. R. Deacon, Man.; T. S. Sims, N.B.; Hon. S. L. Haszard, P.E.I.; W. H. Clarke, Alberta and Sask.

Treasurer, George Booth.

OXYGEN WELDING AND CUTTING PROCESS.

When coal is burnt in the air, the heating effect is the result of the chemical combination of the oxygen of the air with the carbon of the coal. The heat developed rises the temperature of the

Many Important Topics are Discussed Before C.M.A.

Employes' Compensation, Canada's Patent Regulations and Technical Education were Among the Subjects for Discussion---Officers for 1910-11.

Among the subjects discussed by the Canadian Manufacturers' Association were the following topics of general interest.

Workmen's Compensation.

The committee on Workmen's Compensation reported:

"There seems to be a general tendency to stiffen up legislation on the subject of workmen's compensation," says the report. "There is, of course, no denying the fact that the compensation laws as a whole are in a most unsatisfactory state, whether viewed from the standpoint of the employer or of the employee. While your committee are not in a position to bring in any recommendations, they are inclined to believe that there is a good deal of justice in the contention sometimes put forward that the artisan who works for a wage which is little more than sufficient to support his family, and who, while engaged in his regular occupation, suffers injury through no fault of his own, should be entitled to compensation of some sort without having to fight his case through the courts. They feel, therefore, that the association should be prepared to make some concessions. The

tendency, however, on the part of organized labor is to press for legislation which will carry things to the other extreme. If the matter could be compromised by relieving from all further claims for compensation those employers who insure their pay roll up to the extent of a year and a half's wages it would seem as though a solution of the difficulty could be reached, for in that event the cost of insurance could be accurately ascertained by the employer beforehand and provision made for the same, while the employee in the event of an accident would receive the compensation to which he was entitled without having to have recourse to legal process.

Canadian Patent Regulations.

"During the past year it was brought to the attention of your committee that Canada was not a member of the International Convention for the Protection of Industries. This convention, to which most nations belong, has to do with international agreements in connection with patents. For many reasons it seems desirable that Canada should subscribe to this convention, because by so doing any Canadian inventor, on tak-

inert part of the air, viz: nitrogen, as well as the temperature of the gases resulting from the combination with oxygen.

It is obvious that if pure oxygen is used instead of air, the temperature will be much higher, there being no inert as (nitrogen) to heat up. This fact is extensively used in welding by means of blowpipes in which streams of oxygen and combustible gases, hydrogen, coal gas, acetylene and gasoline are mixed and ignited at the nozzle. In the case of acetylene a temperature of above 6,000 degs. Farh. can be easily obtained, and all kinds of metals are quickly brought at the melting point and can be welded up, just like lead in the well known "lead burning" process.

Broken castings of all descriptions (cast iron steel, aluminium, etc.) without any admixture of foreign metals can be easily repaired and made as good as new, and sometimes an enormous saving is done not only in the cost of the repaired part itself, but often on account of the time saved as the repairs can be carried out quickly and saves the time necessary to go through the lengthy process of pattern making, foundry, machine shop, etc.

Besides this very important application, the oxygen welding process is being used in the making of a number of articles, water tight receptacles, pressure tanks of any sizes, tubes of large diameter, welding flanges on tubes, metallic window frames, agricultural implements, bicycles, automobile parts, such as frames, and generally speaking is advantageously use instead of riveting.

The process is so perfect that cracks and corrosions in boilers, (even marine boilers) have successfully been repaired for years, but this work requires specially trained and experienced men.

Another application of the oxygen is the cutting process. Every one knows that red hot iron will burn rapidly in pure oxygen. If a plate of steel or iron is locally heated to redness and a jet of pure oxygen is sent on the red hot spot, in similar way the iron will burn throughout. By moving the blowpipe a clean cut of any shape can be obtained. In this way a cut of one foot long can be made in a $\frac{1}{2}$ inch boiler plate in less than one minute.

The heating flame can be easily produced by means of oxygen and other gases, but the use of oxygen and gasoline enables to have an ideal portable outfit and is the most economical.

By this process, an iron fence which was situated on the Place d'Armes, Montreal, was removed. It was first tried to saw the iron bars, but each cut required

at least $\frac{1}{2}$ hour with two men, whereas by the oxygen process each bar was cut in less than two minutes.

This process is used also for the removal of the Quebec bridge debris; as another example we may also mention that it is intended to be used for the removal of a penstock 12 inches diameter and 20 feet long for a Quebec power company.

A liquid air plant for the production

of oxygen by the process of the Society "L'Air Liquide" of Paris, France will soon be erected in Montreal.

The matter is now in the hands of Mr. R. J. Levy, 3 Monique St., Montreal, who has a demonstration plant at the above address, and who is one of the inventors of this process. It is intended to form a company to take up the manufacture in every province of the Dominion.

Canada Steel Co. Decides to Locate in Hamilton

Large Steel Mill, Machine Shop, etc., to be Erected for the Manufacture of Steel Shapes, Agricultural Shapes; W. M. Currie, Managing Director.

The Canada Steel Co. have decided to locate in Hamilton where they will spend \$400,000 on a large plant and give employment to 300 men. The works will be located on the west side of Sherman Ave., opposite the Atkins' Saw Works.

The Canada Steel Co. was granted a charter by the Ontario Government in May last, while about the middle of June

He is also a director of the Black Lake Asbestos Co., and prominently identified with many important industrial propositions.

Mr. Bertram was formerly president of the Bertram Shipbuilding Co., and at present is the head of the Collins' Inlet Lumber Co. He is also connected with several other large business undertakings.

Mr. Currie, who will be the manager, was formerly the chief inspecting engineer of the Hamilton Steel & Iron Co., and has been a resident of Hamilton for several years. Mr. Malone is of the firm of Malone & Malone, solicitors, Toronto, and Mr. Morrow is the assistant manager of the Central Canada Loan & Savings Co. In addition to these gentlemen the shareholders include some very wealthy men of Toronto and Montreal.

It is the intention of the company to begin work at once on the erection of its plant. The first building to be erected will be the steel mill. This will be a structure of iron concrete and corrugated iron, 250x70 feet. In addition to this, there will be machine shops, stock shed, etc., and an office building. The plant has been designed by one of the largest engineering firms in Pittsburg.

The Products.

The company will roll entirely from old scrap rails. These rails will be bought from railway companies all over the country. The process used is to break them up into the required lengths, after which they are heated and passed through rolls which split them into three pieces—the head, web and flange—and finish them simultaneously into different articles, such as bedstead angles, light structural angles, agricultural shapes of all kinds, concrete bars, light plow beams and sleigh shoes. It will be the only mill of its kind in Canada, and many of the articles rolled, such as angles, have never yet been manufactured in this country. The plant will be operated by electric power, special machinery having been designed for that purpose.



W. M. CURRIE.

Managing Director of Canada Steel Co., Limited.

the steel merger changed its name from the "Canadian Steel Corporation" to the Steel Company of Canada. To avoid confusion as a result of the similarity in names the Canada Steel Co. recently offered to change its name to the Colonial Steel Co. if the Steel Company of Canada would pay the cost of a new charter. The offer was not accepted, however.

The directors of the Canada Steel Co. are F. W. Baillie, Toronto, president; R. M. Bertram, Toronto, vice-president; W. M. Currie, Hamilton, managing director; A. L. Malone, Toronto; G. A. Morrow, Toronto.

Mr. Baillie is a member of the financial firm of Baillie, Wood & Croft.

dicated in drawing Fig. 3 and illustration Fig. 4, the principle of the operation being the removing of a very small section of the tube instead of forcing the tube apart with the bevel wheel cutter as in the usual practice.

It will be noted that Fig. 1 shows the cutter inserted in tube A to be cut, 11 being the body of cutter which holds the cutter in place in tube and 10 a spindle

rotating the saw arbor, it will now automatically feed the saw circumferentially around the tube and finish the cut.

After one end of a tube has been cut there should be a round block of wood a little less in diameter than inside of tube, inserted in the end cut to support the tube while the other end is being cut, which will protect the cutter from any damage by the tube dropping down.

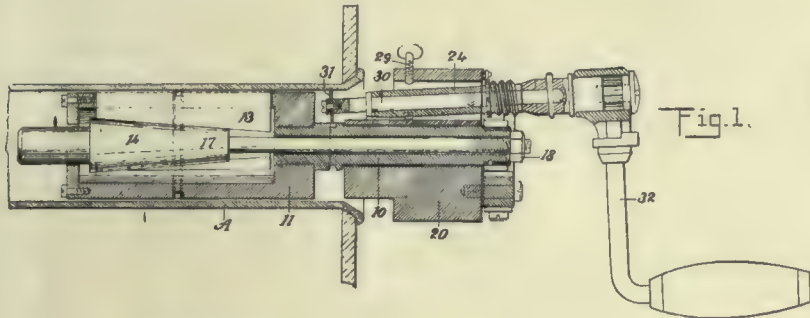
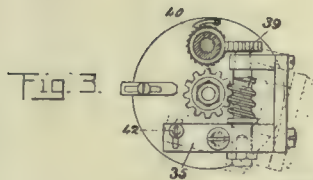

Fig. 1.



Details of Hand Tube Cutter.

attached thereto upon which the cutter head 20, carrying the saw, rotates.

It will be seen that 24 is a sleeve, pivoted at its outer end, carrying the saw arbor 30 and the saw 31 is a small metal slitting saw which cuts the tube. On account of the cutting action of the saw on the tube, the cut being from the outside to the inside leaves the tube with no burr on the outside and does not expand the tube—which will permit the tube being withdrawn through the hole in which it was expanded.

It may be stated that in using the cutter the saw must be down even with outside diameter of body. Then the cutter is inserted in tube so the saw will cut the tube the distance inside the head required. The nut on end of spindle is then screwed up which will clamp the cutter rigidly in tube by means of the conical block and clamping plate. The thumb-screw 42, noted in drawing Fig. 3, is then loosened, the frame 35 which carries worm wheel 39 is swinging out of mesh with 40, after which the thumb screw 42 is tightened.

The cutter is rotated by means of ratchet handle and while so doing the wing nut on side of head is turned to right until the sleeve which carries saw arbor comes in compact with screw on top of head, which will have fed the saw up through the tube.

By turning the thumb screw 29 down on the sleeve, it will hold the sleeve rigid, and the frame 35 is swinging so that worm wheel 39 and 40 mesh. By

after both ends of the tube are cut the small pieces of tube are removed and tube can be drawn through the hole.

USEFUL DIE HOLDER.

By K. Campbell.

I had to use a certain size die very often, and as others wanted to use the stock; I fitted up the die holder in the accompanying illustration. I took two

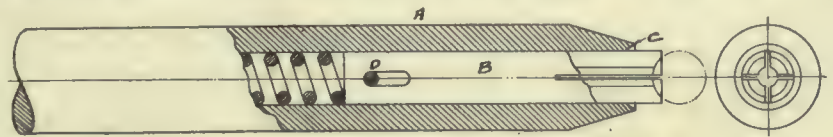

Ball Bearing Set.

pieces of iron AA, and bent them at about an angle of 45 degrees, as shown.

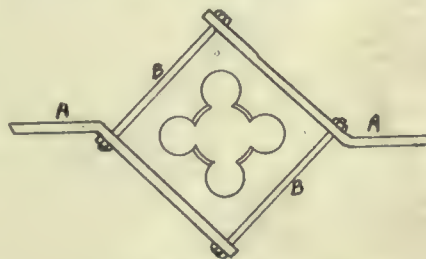

Useful Die Holder.

I drilled the iron for bolts and put them in as shown at BB.

The die is held securely, and is always ready for use. Smaller sizes could

be used by using shorter bolts, but I find it convenient to use the home-made die holder on the one die, keeping it ready for immediate use.

BALL-BEARING SET.

For thrust bearings the London Machine Tool Co., Hamilton, use ball bearing plates. These plates are of brass about three-quarter the thickness of the ball diameter, with straight holes, slightly larger than the balls, drilled through. In these holes, the method of setting, in vogue until recently, was to use a pointed chisel, and burr the edges of the drilled hole at four points, on each side, thus retaining the ball, at the same time allowing free play.

A better setting is obtained by the use of the simple little tool shown in the cut. The barrel A should be of cast steel, bored with a hole the same size as the ball to be set. In this hole is a short rod, B, of the same diameter, which is free to move a short distance by a cross pin D in a slot. The lower end of this rod is centrally cupped approximately to the same radius as the ball, and the end split for a short distance. The upper end bears against a coiled spring, which keeps the rod B always extending beyond the lower end of the barrel, about 1/8-inch. The lower end of the barrel has an annular chisel edge, C, at a diameter about 1-16 in. greater than the ball.

The operation is as follows: The rod B being centrally cupped, centres on the ball when placed on it in the thrust plate, so that the rim C is at a constant distance from the edge of the thrust plate hole when the barrel A is pressed down. A slight blow on the

top will spread the metal, forming a burr inside the hole, which, when repeated on the opposite side of the plate, effectively holds the ball in place, at the same time permitting free motion in its socket.

It is claimed that by this method the production is increased four or five times, at the same time insuring a much better job than was possible by the old method. A very neat appearance is presented to the finished job.

The road to success is not short, and it is not easy, but it certainly is well worth traveling.

A good executive is a man who can get the thing done without hollering himself blue in the face.

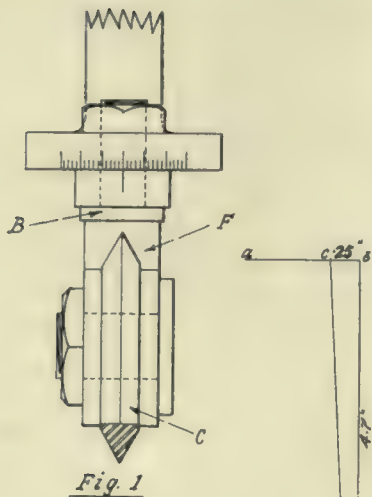

Fig. 1

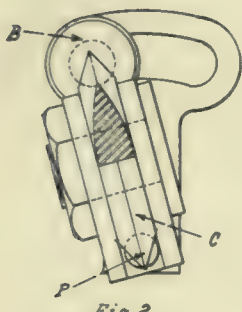

Fig. 2

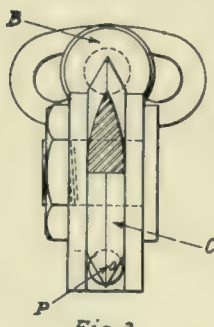

Fig. 3



Fig. 5

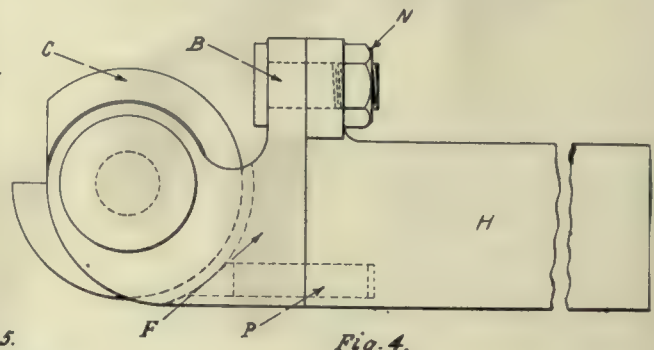

Fig. 4

Thread Cutting Tool.

The "pitch" of a propeller is the distance in which any point in a blade, describing a helix will travel in the direction of the axis during one revolution, the point being assumed to move around the axis. The pitch of a propeller with a uniform pitch is equal to the distance a propeller will advance during one revolution, provided there is no slip. In a case of this kind, the term "pitch" is analogous to the term "pitch of the thread" of an ordinary single-threaded screw.

The following rules are given by Seaton and Rounthwaite for ordinary cases:

THREAD CUTTING TOOL.

By J. H. R., Hamilton.

The accompanying sketch shows a handy tool-holder for cutting threads in the lathe with a single pointed tool.

It is well known that in cutting screw threads on the lathe the clearance of the cutting tool must be ground to an angle corresponding to the angle of the screw to be cut. When there are a number of different threads to be cut having different pitch, and also different angles of advance, several tools are necessary, or as is generally the case, the tool is ground each time to suit the thread being cut.

The device here shown is to overcome to some extent, the usual method of grinding the clearance, or to replace several tools formally used.

In place of the cutter C being held in a solid holder, it is held in a separate fork F, which is secured to the holder H by the bolt B.

Fig. 3 shows the cutter in a vertical position. When cutting a thread, the nut N is released and the fork F revolved on pin P to give the desired cutting angle to the cutter C.

Fig. 2 shows the cutter at an angle of 15 deg. (the limit of inclination in either direction). To determine the angle of inclination, Fig. 5, draw a horizontal line ab, from point a drop a vertical line bo, lay off the circumference of the bolt on the vertical line at bo, and on the line ab lay off the pitch

b c; connect oc. Then boc is the angle of inclination.

Example: Pitch cb equals .25"
Dia. equals 1.5"

Circumference bo=1.05"×3.1416=4.7"

To find the angle:—
side opposite cb .25

Tangent=—————
side adjacent bo 4.7

=.05319.

From a table of trigonometric functions: Tangent boc equals .05319 equals tangent 3.05 degs. equals angle on inclination.

As this solution is somewhat theoretical and might not be understood by some of the readers a more simple method is here given. Proceed as in Fig. 5. With a radius or Fig. 3 describe the arc xy Fig. 5. Then the fork F must be revolved until the centre lines of the graduations are separated by the distance xy.

CORRESPONDENCE.

Comments on articles appearing in Canadian Machinery will be cheerfully welcomed and letters containing useful ideas will be paid for.

Information regarding manufacturers of various lines, with their addresses will be supplied either through these columns or by letter, on request. Address letters to Canadian Machinery, 143-149 University Ave, Toronto.—Editor.

Propeller Wheel.

Give the correct rule to find pitch of a propeller wheel.—Ontario Subscriber.

$$P = \text{pitch of propeller in feet} = \frac{10133S}{R}$$

$$R (100-x)$$

in which S= speed in knots, R= revolutions per minute, and x= percentage of apparent slip.

$$112.6S$$

$$\text{For a slip of 10 per cent, pitch} = \frac{R}{112.6}$$

Another formula for pitch, given in Seaton's Marine Engineering is

$$C \ 3 \ | \ I.H.P.$$

$$P = \frac{C}{R} \sqrt{\frac{I.H.P.}{D^2}}$$

ordinary vessels, and 660 for slow speed cargo vessels with full lines.—Editor.

Addresses of Correspondents.

A number of questions have been asked without giving the name of the correspondent and his address. There have also been several articles for the "Methods and Devices" Department without the names of the contributors. The names should always be given though not necessarily for publication.—Editor.

Keying Locomotive Eccentrics.

We are running British locomotives and I find that those of the most modern type have the eccentric keyed in a different position to those of the older type. Those of the modern type are keyed almost parallel to the arm of the big end and those of the older type are keyed just the opposite. Can anyone say why?—Jos. Arthur.

POWER GENERATION ^A_N^D APPLICATION

For Manufacturers. Cost and Efficiency Articles Rather Than Technical.
Steam Power Plants ; Hydro Electric Development ; Producer Gas, Etc.

CARE OF PNEUMATIC TOOLS.*

By J. H. Simons.**

It is doubtful if any piece of machinery pays a greater profit on its investment or cost than a pneumatic hammer or a pneumatic drill kept in good working condition, yet it is equally doubtful if there is any piece of high speed machinery so much abused by neglect to properly clean, oil and renew worn parts, which condition retards the full admission of air to all the parts, interfering with free movement, and rapidly cuts down the efficiency and capacity of the tools. Pneumatic tools, like all other high class machinery, must receive proper care and lubrication to give the best results. One of the most important factors connected with their proper care is to keep them clean and well lubricated. All pneumatic tool companies should proportion and construct their pneumatic tools in such a way that none of the parts will break from actual service unless some part is defective and escapes the different inspectors' notice at the factory, which is liable to happen once in a great while in the most up-to-date and best regulated plant in the world, but if a wood boring drill, or a metal drill, is improperly applied ; that is, used on other work than for which it was designed and built, or overloaded by forcing it beyond its rated capacity, something may happen. For instance, if a drill is constructed to drill 1½ in. holes and is used for drilling 2 in. or 2½ in. holes, then that something may happen.

It is reasonable, to expect, and it is a fact, that in pneumatic tools, as in all other high-speed machines, the rapidly moving parts will wear in time—the pistons, ball races, balls, throttle valves, etc., in pneumatic drills, and the throttle levers, bushings, valves, pistons and cylinders on pneumatic hammers, and when the wear is sufficient to prevent the full and free admission of air, or the escape of air by leakage past a worn part, it reduces the efficiency of the tools, and the part, or parts, should be removed. If this is done the machines will maintain their efficiency indefinitely.

Needs Lubrication.

The greatest abuse, therefore, to which pneumatic tools can be subjected

is the failure to properly clean and lubricate them. An almost universal feeling seems to predominate on the part of operators that a pneumatic tool should run and develop its full power so long as all the parts are held together, without any regard to cleaning, oiling or tightening up. The cleaning and oiling of pneumatic tools should not be delayed until they stop working on account of dirt, rust or gummed oil. **THEY SHOULD BE THOROUGHLY CLEANED WITH KEROSENE OR BENZINE ONCE EVERY TWENTY-FOUR HOURS**, as the air taken into the compressor generally contains some grit or dust. It is almost impossible to prevent this foreign matter entering the working parts of the tool, thus causing the parts to become clogged and rendering the tool inoperative. A good plan in such cases is to thoroughly clean by pouring benzine or kerosene freely into the throttle handle. This dislodges all foreign matter and cuts the thick oil, which can be removed by blowing the air under pressure through the tool, then lubricate in like manner with a good quality of light body oil. Sewing machine oil or a winter strained lard oil is very good. Heavy oils should never be used on pneumatic hammers or piston drills, as they cause the tool to work very sluggishly, with consequent loss of power. However, heavier oils should be used on the rotary type of drills.

When Not in Use.

When pneumatic tools are not in use it is a very good plan to keep them immersed in kerosene. They should be suspended so that the dirt and foreign matter will settle to the bottom of the vessel and then be thoroughly blown out and well lubricated before being put into operation, as kerosene leaves them dry. It will well repay any user of pneumatic tools to keep the inside of pneumatic tools as clean and well-oiled as a sportsman would his gun. We advocate, especially where the air is usually laden with foreign matter, the use of strainers on the tool and filters in the pipe line, arranged so that they can be readily taken apart and cleaned. A good form of pipe line filter is two cast flanged pieces properly tapped and threaded to fit the pipe line, bolted together, with a piece of gauze or fine mesh wire screen between. This can be made in any railroad shop. There are also sundry makes of automatic oilers for pneumatic tools, which are placed in

the hose line a short distance from the tool, and which can be refilled at any time without disconnecting the tool from the hose line. They are made in sizes to supply oil for from six to eight hours without refilling.

Use Proper Pistons.

Another abuse, especially with regard to pneumatic riveting hammers, is a rapidly increasing tendency on the part of operators, particularly where the hammers are used in construction of steel cars and in structural steel shops, **TO USE PISTONS SHORTER THAN THOSE ADOPTED BY THE MAKERS AS STANDARD, THIS IS THE MOST FLAGRANT ABUSE TO WHICH A RIVETING HAMMER CAN BE SUBJECTED**, and I cannot too strongly condemn this practice. The riveting hammers are designed with parts properly proportioned to meet the requirements of the various classes of work to which these tools are adapted. Workmen have discovered that a shorter piston than the one furnished with the hammer increases the number of blows per minute and for a time facilitates their work.

They usually make these pistons by grinding down a broken standard piston, thus removing the hardening in a large degree, and leaving the striking part softer than it should be. These short pistons have a tendency to crumble, and the broken parts cut the inner casing of the cylinder, and if it is not damaged beyond repair from this cause it is only a question of a short time when the cylinder will crack or the handle will be broken.

When cracked cylinders, broken handles and rivet sets are experienced hammer should be carefully examined to ascertain whether or not the workman has substituted a short piston and this can only be done when the hammer is in service, as it has been found that the workmen carry the short pistons with them and make the exchange after taking the hammer out of the tool room, replacing the proper piston when returning the hammer at the close of the day.

In some of the large manufacturing plants hammers have been discovered working with a short stub of a piston not more than two inches in length, ground conical on the striking end, and the managers of these plants have issued instructions making it an offense punishable by discharge where such

* Read before Railway Tool Foremen's Association.

** Of Ingersoll-Rand Co., Toronto.

conditions are found. One of our largest industrial organizations, operating some eight or ten plants, inaugurated about a year ago a system for keeping a thorough inspection and record of pneumatic tools from the day of purchase until they had become obsolete or worn out. A record is kept of every item of repair made to a tool and a report is filed showing why the repairs are made necessary, that is, whether from abuse, lack of care, bad hose, natural wear and tear, or accident. The mechanical engineer in charge recently informed me that in looking over the report for first six months he was greatly surprised to find that about 30 per cent. of the causes of repairs could be directly attributed to neglect in cleaning and oiling and about 15 per cent. to the use of inferior hose.

Importance of Air Pressure.

Another important factor to be considered in the getting of the very best results out of pneumatic tools is the air pressure. We have found after a very careful and painstaking investigation that, so far as the air pressure is concerned, ONE SHOULD HAVE BETWEEN 90 AND 100 POUNDS OF AIR TO GET THE BEST RESULTS. THE CANADIAN GOVERNMENT WILL NOT ACCEPT STEAM TIGHT RIVETS DRIVEN WITH PNEUMATIC HAMMERS UNLESS THESE HAMMERS ARE OPERATED BY 110 POUNDS AIR PRESSURE. All pneumatic tools can be operated on less pressure, but you will find, as I say that 90 to 100 pounds of pressure will give the best results.

Suggestions.

In conclusion allow me to offer A FEW SUGGESTIONS APPLYING TO ALL MAKES OF PNEUMATIC TOOLS, WHICH, IF FOLLOWED, WILL INSURE YOU MORE AND BETTER WORK FROM YOUR EQUIPMENT and will obviate delays and annoyances and minimize the expense of maintenance.

First, see that the tools are well cleaned and oiled before putting them in operation.

See that the pipe lines are thoroughly blown out before connecting the tool.

Use the best quality of air hose. It is cheaper and more satisfactory in the long run.

See that your pipe lines are provided with filters or that strainers are used with the tools, preferably both.

With drills, adjust the ball-bearings, where they are provided, so as to take up the lost motion, and be sure that they are firmly held by the lock nuts to prevent working loose or tightening up and binding when in use.

With your pneumatic hammers be sure that the handle is always on tight,

as the tools may be seriously injured by allowing this to work loose. This controls the joint between the handle in valve box and is of great importance.

See that the operators hold their riveting and chipping hammers firmly against the work. If the die or chisel is allowed to play in and out of the hammer while in operation it will seriously damage the tool. Every blow should be delivered on the die or chisel and not on the forward end of the bridge of the cylinder in chipping hammers. With riveting hammers, which have no bridge in the cylinder, it often means the loss of the die and piston by being shot out of the tool. Besides, in structural work it makes it dangerous to pedestrians in streets and thoroughfares below. There is no way of protecting against injuries of this nature except by care on the part of the operator.

See that the chisel and rivet sets fit properly in the nozzles and are of proper length, otherwise there is an opportunity for loss of power and injury to the tool.

LENGTH OF BELT.

By S. H. W. Sackville.

A simple method of finding the required length of belt for open-running

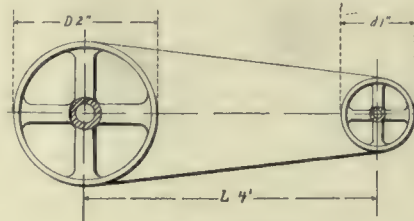

Length of Belt.

pulleys not in position can be approximately obtained thus, where:

D=dia. of the large pulley in ins.

d=dia. of the small pulley in ins.

L=distance between shafts in ins.

B=length of belt in ins.

Dd

$B=3\frac{1}{4}(-)+2L=12.875$ ins., or $12\frac{7}{8}$

ins.

STEAM CONSUMPTION OF COMPRESSORS.

Suppose that a compressor is required to compress 500 cu. ft. of free air a minute, delivering to a receiver at 100 lb. gage. A two-stage machine of that capacity will require approximately 92 i.h.p. to perform the work. Now, while the best straight line compressors are furnished with Meyer valves, they are usually set by the operator to cut off constantly at about three quarter stroke, and with such setting they will require on an average 45 lb. of steam per horse power hour, while Corliss

duplex machines with cross compound steam cylinders will do the work with 15 lb. of steam or less. There is not only thus a saving of two-thirds of the coal consumption, but also a corresponding reduction of boiler plant, and the labor and other cost of its operation.—Compressed Air Magazine.

OBITUARY.

General regret is expressed at the death of Miss Dorothy Hobson, daughter of Robert Hobson, general manager of The Steel Company of Canada, Hamilton. Her death was the result of an unfortunate automobile accident.

Hugh McCulloch, Sr., president of the Goldie & McCulloch Co., Galt, Ontario, died on Saturday, September 3. Mr. McCulloch was born in Scotland in 1826, and was in his 84th year. He came to this country when a boy, and had been a resident of Galt, since 1850. He started work for James Crombie in 1851 and in 1859, with the late John Goldie, they purchased from James Crombie the Duffries foundry, a small institution employing 22 men. At first general foundry work was done, but as the business grew the firm went into the manufacture of boilers, engines, flour and sawmill machinery and wood-working machinery. Thirty-one years ago, the firm went into the manufacturing of safes and vaults, in which department great success was achieved. The advancement of the trade led to a joint stock company being formed in 1891. In 1896 Mr. Goldie died, and his son, A. B. Goldie, took his place, and is to-day manager of the works. He is survived by two sons and one daughter, Hugh McCulloch, Jr., vice-president, and R. O. McCulloch, secretary-treasurer of the firm, and Mrs. Shearson, of New York, and one brother, George, of Souris, Man.

George Archibald Bain, superintendent and a director of the Bain Wagon Works, died recently. The Bain Wagon Works were established in 1882 by George A. and his brother, John A. Bain.

PERSONAL

E. Crabtree, for many years a machinery representative of H. W. Petrie, Ltd., Toronto, leaves on Oct. 14 for England, on a business trip for the purpose of appointing agents for machine tools, etc., and for companies desiring foreign connections. He will also secure additional agencies for the H. W. Petrie Company.

Wm. Brown, for some years connected with the Canada Iron Corporation at Londonderry, lately as manager of the steel plant, has severed his connection, and is succeeded by Leo G. Smith, formerly of the Bucyrus Steel Castings Co., Bucyrus, Ohio, and recently superintendent under Mr. Smith.



SAVING CENTS.

By R. Ewart Cleaton.*

There is an old English saying, "Look after the pence, and the pounds will look after themselves," and this as surely applies to cents and dollars, as to any other currency. The following little items will tend to effect econo-

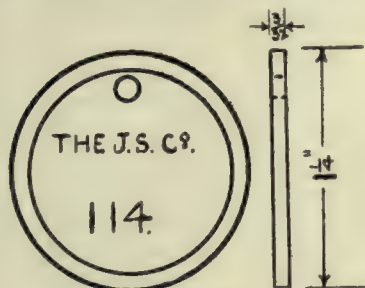

Fig. 1.—Saving Cents.

mies, which although perhaps not noticeable in a direct manner, will be very evident by the increased output, and efficiency, occasioned thereby. Doubtless there are many up-to-date plants where these ideas are in operation at present, but there are plenty of others where there is great need for improvement.

When a shop is run on the piecework or standard time system, a great deal of bad feeling and unnecessary irritation is caused if the men are obliged to wait about for work, between jobs, or for the necessary tools to perform that work. THIS CAN BE AVOIDED BY HAVING AN EFFICIENT ROUTING SYSTEM, AND A WELL EQUIPPED TOOL STORES, TO WHICH ARE ADDED DRAWING AND JIG STORES.

As the former has been dealt with to a great extent of late, I will confine myself to the three latter.

These should be situated in a central and accessible position; articles should be issued only in exchange for a brass check (Fig. 1) with the name of the person and the number of the workman stamped upon it; a list of the names, and numbers of the workmen being kept by the storekeeper, the tools, jigs, and drawings, already issued, can be easily located. In the case of small tools, gauges and drills, which are kept

in sub-divided drawers, the checks are put into the division from which the article has been removed, whilst for those tools kept on shelves or racks, a black painted board or series of boards are used; these have a number of hooks, on which the checks are hung, underneath the name and size of the tool, which are either painted on permanently, or temporarily written in with chalk. Jigs should be treated in a like manner, although in the case of large and heavy ones, it is preferable, when they are used by only one special machine, to leave them in some convenient place nearby, when not in use.

ALL JIGS SHOULD BE STAMPED WITH THE DRAWING AND PART NUMBER OF THE ARTICLE FOR WHICH THEY ARE INTENDED.

Drawings should be of standard sizes, and mounted on heavy cardboard, which, although pliable, will not buckle or crack.

The life of a drawing is lengthened by applying a coat of varnish or shellac, the latter is preferable as varnish is liable to become sticky.

As it is usual to place all parts destined for a similar purpose under the same group number, this, together with the number of the drawing, should be stencilled on the top back left hand corner, in large black letters on a white background, Fig. 2. If the drawings are then kept in their respective groups, and numerically arranged to stand on end in racks, it is a very easy matter

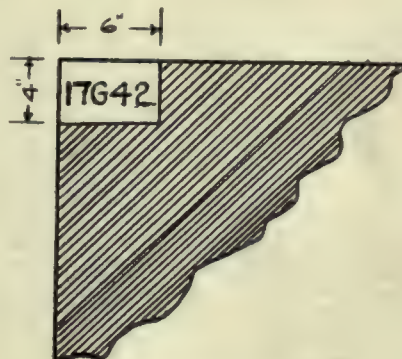

Fig. 2.—Saving Cents.

to quickly find the required one, after having ascertained by referring to the board that it is not already issued.

These matters may appear insignificant in themselves, but when taken as parts of a system will be found to be instrumental in saving innumerable cents (the dollars will look after themselves!) when the time saved by the storekeeper in issuing, and that of the user of the articles, is taken into consideration.

In order to turn out good work, accurate tools, such as calipers, squares, feelers, etc., are necessary, and to encourage and stimulate the possession of these by the workmen, an offer of a discount on the catalogue price will be found to be efficacious. This can be done without cost to the management, by the tool room foreman obtaining the shop agency for any well-known firm of small tool manufacturers; the tools can then be supplied to the employe at the cost at which they are obtained from the makers. The latter will usually be willing to furnish a showcase containing an assortment of the tools made by them, which can be hung in a prominent place, in order that any intending purchaser may see exactly what he is ordering.

IN CONCLUSION, I WOULD LAY STRESS ON THE ADVANTAGE OF KEEPING THE STORES SPICK AND SPAN, AND THE TOOLS IN GOOD CONDITION, AND FREE FROM RUST OR DUST, which will not only have the effect of conveying a good impression to visitors passing through the works, but will also cause the employes to whom the issue is made to return the article for which he is responsible, whilst it is out on his check, in a condition similar to that in which it was given out, allowances of course being made for wear and tear.

ROUTING SYSTEM.

By F. H. M.

The system in use by the McLaughlin Carriage Co., Oshawa, for following up the various parts that enter into the make-up of an automobile, buggy, or cutter, is one that might readily be adapted to the sorting of machine parts that are made in large quantities.

While the system is not exactly new, being somewhat similar to a couple of other systems in use on factories pro-

* Of the piece work and shop methods department, C.P.R. Angus shops, Montreal.

CANADIAN MACHINERY

AND MANUFACTURING NEWS

A monthly newspaper devoted to machinery and manufacturing interests mechanical and electrical trades, the foundry, technical progress, construction and improvement, and to all users of power developed from steam, gas, electricity, compressed air and water in Canada.

The MacLean Publishing Co., Limited

JOHN BAYNE MACLEAN, President W. L. EDMONDS, Vice-President
 H. V. TYRRELL, Toronto Business Manager
 G. C. KEITH, M.E., B.Sc., Toronto Managing Editor
 FRED H. MOODY, B.A. Sc., Toronto Associate Editor

OFFICES:

CANADA

MONTREAL Rooms 701-702 Eastern

TOWNSHIPS Bank Bldg

TORONTO 143-149 University Ave.

Phone Main 7324

WINNIPEG, 511 Union Bank Building

Phone 3726

BRITISH COLUMBIA - Vancouver

H. Hodgson,

Room 21, Hartney Chambers

GREAT BRITAIN

LONDON - 88 Fleet Street, E.C.

Phone Central 12960

E. J. Dodd

UNITED STATES

NEW YORK - R. B. Huostis

1109-1111 Lawyers' Title, Insurance and Trust Building

Phone, 1111 Cortlandt

FRANCE

PARIS John F. Jones & Co.,

31bis, Faubourg Montmartre,

Paris, France

SWITZERLAND

ZURICH - Louis Woll

Orell Fussli & Co.

Cable Address:

Macpubco, Toronto.

Atabek, London, Eng.

SUBSCRIPTION RATE.

Canada, United States, \$1.00, Great Britain, Australia and other colonies 4s. 6d., per year; other countries, \$1.50. Advertising rates on request.

Subscribers who are not receiving their paper regularly will confer a favor on us by letting us know. We should be notified at once of any change in address, giving both old and new.

Vol. VI.

October, 1910

No. 10

THIS love of one's work is at the root of all success. The proportion of successes to failures in business life is in a very decided minority, and if we reckon the partial failures and the milk-and-water successes, the ratio dwindles. Success to a marked degree can only be obtained by the man who is really in love with his work. It is not sufficient to be content or fairly well satisfied with the returns of one's work, or to make just enough effort to keep out of trouble. Big dividends will never be made or big businesses built up if one regards work as a necessary evil, something to be endured and forgotten at the earliest possible moment or when the shutters are down. Show me the man who is really in love with his work, his business, his profession—his *job*—and you will point to the man who is bound to rise to success by reason of his enthusiasm, his vitality, his imagination, and his breadth.—George H. Frost, in the *Organizer*.

WORKMEN'S COMPENSATION

For a number of years Canadian Machinery has carried on a campaign for the protection of machinery and thus the elimination of a large number of industrial accidents. We recognize that accidents will happen, and, unfortunately, they are often attended by loss of life or limbs. If an employer was generous he made a position for the maimed workmen or provided for the widow and family. Sometimes the workman or his family made use of the courts but as companies with large capital at their back could appeal decisions and carry cases beyond the means

of workmen, the final decision inevitably resulted in favor of the company.

In view of the above, therefore, it is gratifying to note that the Canadian Manufacturers' Association is taking cognizance of the workmen's claim for consideration and are trying to find a remedy for the conditions that now surround workmen. The Association suggests that

"If the matter could be compromised by relieving from all further claims for compensation those employers who insure their pay roll up to the extent of a year and a half's wages, it would seem as though a solution of the difficulty could be reached that would be satisfactory to both sides, for in that event the cost of insurance could be accurately ascertained by the employer beforehand, and provision made for the same, while the employee in the event of an accident would receive the compensation to which he was entitled without having to have recourse to legal process. This arrangement, of course, presupposes that the employee would insure himself for an amount equal to that carried for him by the employer, so that in the event of fatality his family would receive the equivalent of three years' wages, which is generally conceded to be about right."

No doubt if an arrangement can be arrived at, it will help to remove any hard feelings existing between capital and labor on this account. A voluntary system of compensation might work satisfactorily in certain cases but in others, it would require the strong arm of the law to enforce workmen's rights. The question is one that could be dealt with by either the Provincial Governments or the Labor Department of the Dominion Government, to advantage.

ARE WE OVERDOING THE MERGER IDEA?

Canada will get no good from an undue development of the merging tendency. The last few years, and especially the last few months, have witnessed a remarkable increase in the number of industrial consolidations. Most of them will undoubtedly work to Canada's advantage but some of them are destined to have careers that will bring no particular credit upon this country. This does not imply that there will be failures of these amalgamations, but the progress of many of them is unquestionably to be very tedious and many shareholders both at home and abroad will be long disappointed before they begin to receive the returns expected.

There is of course nothing wrong with the merger principle. Important economies in managements, freight charges, selling costs and the like are usually achieved by the properly conceived and executed merger. The trouble at the present time is that in some cases it has been taken advantage of by certain promoters who are bringing industries together in a way and on terms which are utterly unjustified. The interests that bring about the consolidation sometimes have only their own profits in consideration. This leads to entirely too high prices being paid to the merging organizations, the new company becomes loaded up with capital obligations which for many years cannot be made to represent real assets. The Dominion has everything to gain from consolidations of its industrial interests which will enable them to meet the rapidly-growing needs at home and to compete vigorously for the business to be had abroad. It cannot afford, however, to mortgage its manufacturing and trade future through the multiplication of amalgamations for which there is no economic justification.

THE DOMINION'S FINANCIAL POSITION

The statement of the condition of the Dominion's finances as at August 31st, 1910, appeared in the Canada Gazette of September 10th. The loan accounts show a pleasing decrease of almost \$18,000,000, in Funded Debt Payable in London, and of over \$7,000,000 in temporary loans, as compared with Aug. 1909. The large volume of business being done in the country is reflected by a \$11,000,000, or a 14 p.c. increase in Dominion notes in circulation, while the Bank Circulation Redemption Fund also reflects the same condition with an increase of some \$200,000 over the corresponding period. The same tendency, as for a long time back, is shown in the position of the Government Savings Banks, which show a further decrease of almost \$1,000,000 in a total of \$58,000,000, as compared with August a year ago. It is evident that the public are becoming more and more aware of the fact that it is better policy to place their deposits with the chartered banks where the funds are available for the general commercial uses of the community. Miscellaneous and banking accounts are practically double last year's figures, which makes the gross debt practically \$1,000,000 larger than a year ago, the total now being \$472,141,823.88. On the Assets side, Sinking Funds are corresponding to the smaller Funded Debt, also very much lower than in August, 1909. The figures are respectively \$15,200,000 and \$39,200,000. The month just closed shows a decrease in total net debt of \$1,270,000, the present net indebtedness of the Dominion being \$327,345,552.16, or some \$46 per capita.

The much larger volume of trade of the country is indicated by the Customs receipts, which for the month were \$6,500,000, as against \$5,300,000 last August, the total to August 31st being \$29,566,000, against \$23,283,000 for the first eight months of 1909. Excise duties are also about 25 p.c. higher this month, while in Public Works expenditure practically a similar increase is shown over a year ago. Capital Expenditure on Public Works, including railways and canals was for the month \$3,200,000, or a total for the year to date of \$8,500,000. These are in contrast with \$2,450,000 for last August and \$7,300,000 for the year to August 31st, 1909.

The total revenue for the month just passed is \$10,174,930 or \$1,705,082 more than for the same month in 1909, while the expenditure for the month is \$66,000 less than last year. For the year to date the total revenue has been \$45,830,370, against \$38,500,000 last year, while the expenditure to September 1st this year is \$27,546,017, which is only \$1,192,838 more than for the same period last year and \$18,284,353 less than the revenue.

SCIENCE AND INDUSTRY

At the British Association meeting, held recently at Sheffield, a paper was read by Mr. R. Blair, M.A., B.Sc. (Education Officer, London County Council) on "The Neglect of Science by Commerce and Industry," in which he brought forth several unsolved problems, the result of twenty-five years of research.

Mr. Blair contended that our locomotive engines are not designed or constructed upon scientific and economic principles; and that the "rule-of-thumb" positively prevails in that industry almost as much as in any other, to the danger of the general travelling public.

The "rule-of-thumb" methods are usually an evolution of some other methods previously used, no employe having the desire to work out for himself from a scientific standpoint the rules applicable to a particular case. Other unsolved or neglected problems were also presented by

Mr. Blair which should receive the attention of manufacturers:

"The co-efficient of friction between the driving wheels and the rails being known, I do not think there is a living locomotive engineer or professor who can graphically and correctly determine the limit of an angle of repose of the driving wheel of an engine with, and without, trailing wheels.

"The scientific world has hitherto failed to produce a text-book showing how to determine the mechanical effect of the draw-bar pull upon the wheel-base of an engine and how it affects tractive efficiency.

"The vast industry of carriage and wagon building has not one practical or scientific man who knows how to graphically and scientifically suspend a vehicle upon its wheel-base. Although every builder knows full well that one vehicle runs much easier than another of the same weight, differently suspended, yet no one seems to know how to resolve and explain the responsible forces.

"The automobile—I do not know of the existence of any engineer who knows how to determine the limit of the angle of repose of the driving wheels of an automobile on different conditions of roads and grades, etc."

A remedy is suggested which, it is hoped, will increase the knowledge of forces, etc. "Teachers of elementary mechanics should begin to interest their young students by a clear and simple explanation of the mechanical and physiological forces which are brought into play in all their pranks and sports, for, when they become informed of all the forces which they themselves are exerting they will proceed to practical experiments, devising and constructing all manner of things according to their own views and abilities."

A good method for removing rust from steel is to first rub the object with sweet oil, and then after a day or two, rub it with finely powdered unslacked lime until the rust disappears. Then give it again a coating of oil with a woolen cloth, and put it in a dry place.

If a punch, reamer or other tool is to be hardened, and the color resulting from that process is undesirable, it may be removed by the following simple method: After the part is hardened, dip it into a glass filled with muriatic acid and allow it to remain for five seconds; then plunge it into a pail of water. In this way the polish of the steel will return and the temper will not be affected. This method is much quicker than obtaining a polish by the use of emery cloth.—Machinery.

The following recipe for a non-shrinking alloy was recently published in the Metal Industry: Tin, 50 pounds, and zinc 50 pounds, gives a tough, hard metal that runs well. It is improved by the addition of 2 pounds of bismuth. By the use of heavy sprues, and by pouring cold, the slightest shrinkage may be largely overcome.

According to a paper read before the Pittsburg Foundrymen's Association, large patterns made of concrete reinforced with wire have been successfully used in a foundry at Niagara Falls, N.Y. The cost of these patterns is very much less than that of ordinary wooden patterns.

According to the Brass World, an aluminum alloy containing an average of 96 per cent. aluminum, 2.5 per cent. copper, 0.75 per cent. manganese and 0.75 per cent. silver can be rolled and drawn and is then much stronger than pure aluminum. The rolling may be done either hot or cold.

DEVELOPMENTS IN MACHINERY

New Machinery for Machine Shop, Foundry, Pattern Shop, Planing Mill; New Engines, Boilers, Electrical Machinery, Transmission Devices.

DART HAMMER MOLD.

Every mechanical man knows how necessary a soft metal hammer is when working on particular work, and with the Dart hammer mold he can easily make his own hammer at practically no cost and avoid the risk of using a make-shift. The Dart hammer mold is of iron, with skillet attached, and molds a 3-lb hammer solidly to the handle. It is one of the handiest kind of tools to have in the machine shop.

The opening in the mold for the handle is the size of a half-inch gas pipe, which is best to use, as it is light and places the weight of hammer where it does the most good, although solid handles may be used if desired. Split one end of the pipe and spread it a little; it gives the metal a better hold; then plug the pipe at the split end, so as to prevent metal from flowing through the handle; something solid is the best, as it saves



Dart Mold for 3lb. Soft Metal Hammer.

doing again when a new head is molded on, for the same handle can be used repeatedly.

Place the handle in mold; clamping the mold on it with the little ring by tightening the set screw on top down snug.

Everything is now ready for the melting. When the metal is hot enough, slowly run it into the mold; do this by using the handle to tilt the mold. The little air-hole at side of run tells when the hammer is filled.

Do not let the mold proper be hotter than is absolutely necessary, as it will take longer for the hammer to cool. Under fair conditions a minute's time is all that is required.

This handy device is manufactured by the Dart Union Co., 93 Niagara Street, Toronto.

PORTABLE LIMESTONE PULVERIZER.

The accompanying illustration shows the mechanical features of a Jeffrey

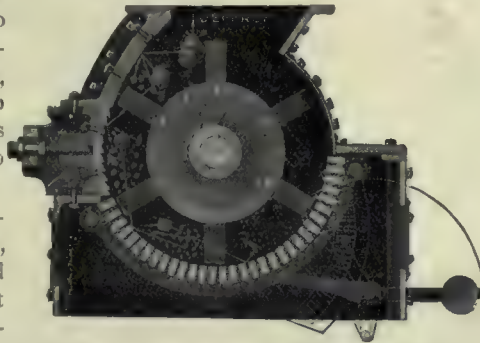

Fig. 2.—Inside View of Jeffrey Pulverizer.

portable limestone pulverizer. Fig. 1 shows the pulverizer complete, the interior mechanism being shown in Fig. 2. This machine has a capacity for re-

ducing one ton of limestone per hour, $\frac{1}{8}$ inch and finer. It is belt driven and connected to a small 15 h.p. gasoline

engine. It is manufactured by the Jeffrey Mfg. Co., Columbus, Ohio.

PORTABLE CRANK PIN TURNER.

The Schweinebraten Portable Crank Pin Turning Machine Co., Birmingham, Ala., are placing on the market a portable crankpin turner, shown in the illustration. The machine can be adjusted to any pin. Those being made now have the main bearing chased out

to suit a $2\frac{1}{2}$ x8 thread gudgeon screw, but by a reducer or extension the machine can be fitted to any pin.

The machine consists of three parts, and fits tight against the end of the



Portable Crank Pin Turner.

crank pin. It will finish a crank pin in $1\frac{1}{2}$ hours. As shown it is driven by a pneumatic drill. The total weight of turner is 80 lbs.

PRACTICAL ENGINEERS' POCKET BOOK.

The Magnolia Metal Co., 225 St. Ambrosie St., Montreal, have issued a special Magnolia Edition of the practical engineers' pocket book issued by the Technical Publishing Co., London. The book contains 680 pages and treats on over 2,000 engineering and mechanical subjects. It would be impossible in small space to give an idea of the subjects treated by this book, but such subjects as machinery and tools of all descriptions are taken up including gauges, power equipment, machine shop equipment, steels, power generation and transmission, water wheels, patents, refrigeration, lubrication, grinding, springs, rules

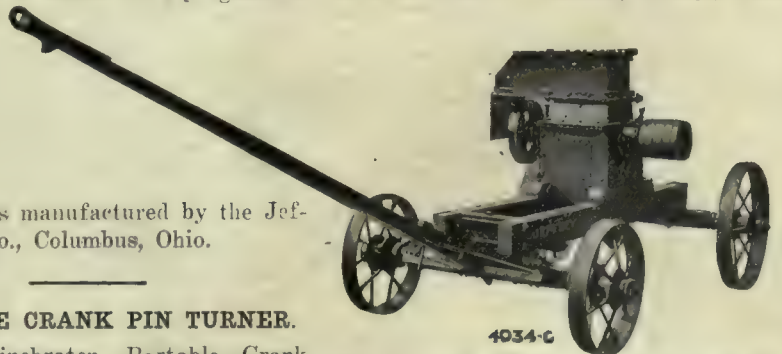

Fig. 1.—Jeffrey Portable Limestone Pulverizer.

for work, etc. A small charge of 40 cents is made, on receipt of which the book will be mailed postpaid to any address.

Recent Advances Made in Herbert Machinery

Some Methods Followed in the Alfred Herbert Shops, and Recent Improvements made in the Design of their Machine Tools.

The firm of Alfred Herbert, Ltd., was established in 1888 at Coventry, the business first engaged in being the building of light machine tools for the cycle industry. The firm now employ 1,500 men manufacturing a line of labor saving machine tools, including turret lathes, automatic screw machines, horizontal and vertical milling machines, etc.

The work is carried through on a strictly repetition system, the greatest possible use being made of jigs and fixtures. Owing to the large number of different sizes and types of machines

machines is then put in hand. The order for this batch goes to the stores, together with a complete list of parts, this latter being supplied by the drawing office. The stores then issue orders for the necessary raw material and issue same to the various departments in the works.

The piece work prices for every operation on every particular part are fixed by the piece work office, and are entered on process cards which are handed to the stores from the piece work office. The stores then issue the necessary piece work tickets, and inspection

keeper has a book containing particulars of these stock parts with instructions as to the maximum and minimum number that are to be in stock at any one time. When his stock is getting low he sends an order into the works for the maximum number which is sufficient to enable the work to be done by the most economical method, usually on automatic screw machines.

Inspection continues during the process of erection, and when the machines are completed they are finally inspected for alignment and finish and are then handed over to the testing department, which is under the control of the selling department.

A large part of the firm's business consists in supplying machines equipped with tools and fixtures for producing specified work to sample, or drawing.

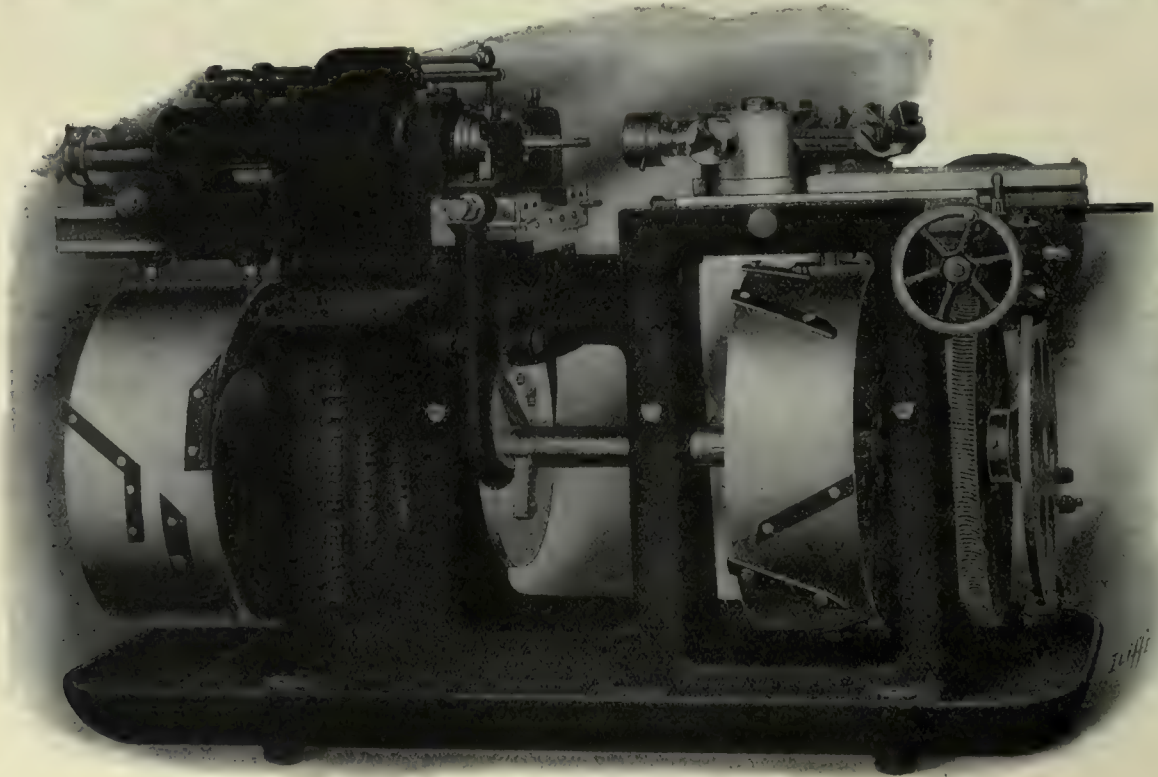

Fig. 1.—Automatic Screw Machine.

which are built, it is necessary to put them in hand in batches of from 12 to 24, according to the size of the machines, this in order to ensure the different batches being repeated at fairly frequent intervals.

Piece work is employed on all operations except the final testing of the machines, and a very thorough system of fixing prices, and keeping track of the work in the shop is followed.

Testing.

When a new machine is designed, the first one is built and tested in an experimental department, which is entirely separate from the rest of the works. After a very thorough series of tests, any necessary alterations are made to the design, and a batch of the

takes place at the finish of every operation, the workman being credited with the amount of work passed by the inspectors. The stores obtain from the foremen a date of completion of their department's work on the batch in question, and from these dates, a date for delivery of the complete machine is made out.

When all the machining is finished the parts are issued to the erectors together with such components as are carried in stock independent of batch orders for machines. These components represent articles which are common to a number of machines such as handles, collars, screws, lock-nuts, etc. These are known as stock parts, and are made to the storekeeper's order. The store-

orders being accepted for such machines and outfits on condition that a guaranteed time or production should be fulfilled in the customer's presence before delivery, and such guarantees are carried out in the testing department above mentioned.

Special Screw Machines.

Fig. 1 shows an automatic screw machine of which the firm build eleven different sizes. They also make special machines for the production of copper stays for locomotives, condenser ferrules for marine condensers and double ended screwed studs.

In 1907 it was found necessary to build a works at Edgwick about three miles from Coventry, where is situated the foundry. These works are devoted to

the building of horizontal and vertical milling machines.

Fig. 2 shows the Herbert plain horizontal miller, which is built in three

respectively. It will be noticed that the design is compact and gives evidence of great power and rigidity. Two ratios of back gearing are employed,

ensuring efficient belt contact. The test out which the largest of the three plain millers must fulfill is as follows :
Material..... Cast Iron

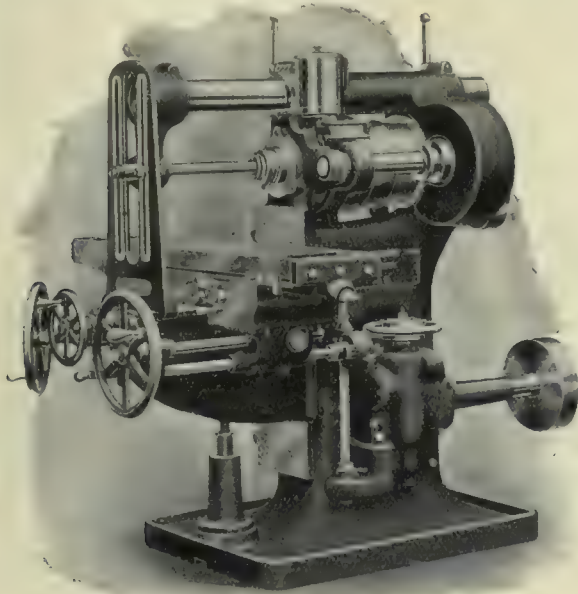

Fig. 2.—Herbert Plain Miller.

sizes having automatic longitudinal feed to table of 28-in., 34-in. and 42-in.

which enables the small step of the cone pulley to be kept large in diameter,

Hardness..... 238 Brinell
Width of cut 5-in.
Depth of cut 5-16 in.
Feed per minute..... 12 in.
Metal removed per minute, 18.7 cub. ins.

It will be noticed that the feed motion is driven by a single pulley. This may be either belted up to the spindle of the machine or driven direct from the countershaft. Messrs. Herbert strongly recommend the latter as it makes the feed of the table entirely independent of the feed of the spindle. The rate of feed is altered by simply rotating the hand wheel seen on the feed bracket. To this hand wheel is attached a dial on which are marked the different rates of feed in inches per minute when driven from the countershaft, or in inches per revolution when driven from the spindle. To obtain any desired feed, therefore, it is merely necessary to rotate the dial until that feed comes opposite a fixed pointer. This is believed to be the simplest feed changing mechanism on the market, and is applied to all Herbert's machines.

New Milling Machine.

Fig. 3 shows a recent design of vertical milling machine having a capacity of 48-in.x18-in.x26-in. This machine has constant speed drive through single pulley which by means of gearing running in oil, gives 16 speeds to the spindle. Automatic motion is provided to the longitudinal and cross movement of table, vertical feed of spindle head and rotary motion of circular table, all these feeds being reversible and controlled by the dial feed motion described above. The circular table can be

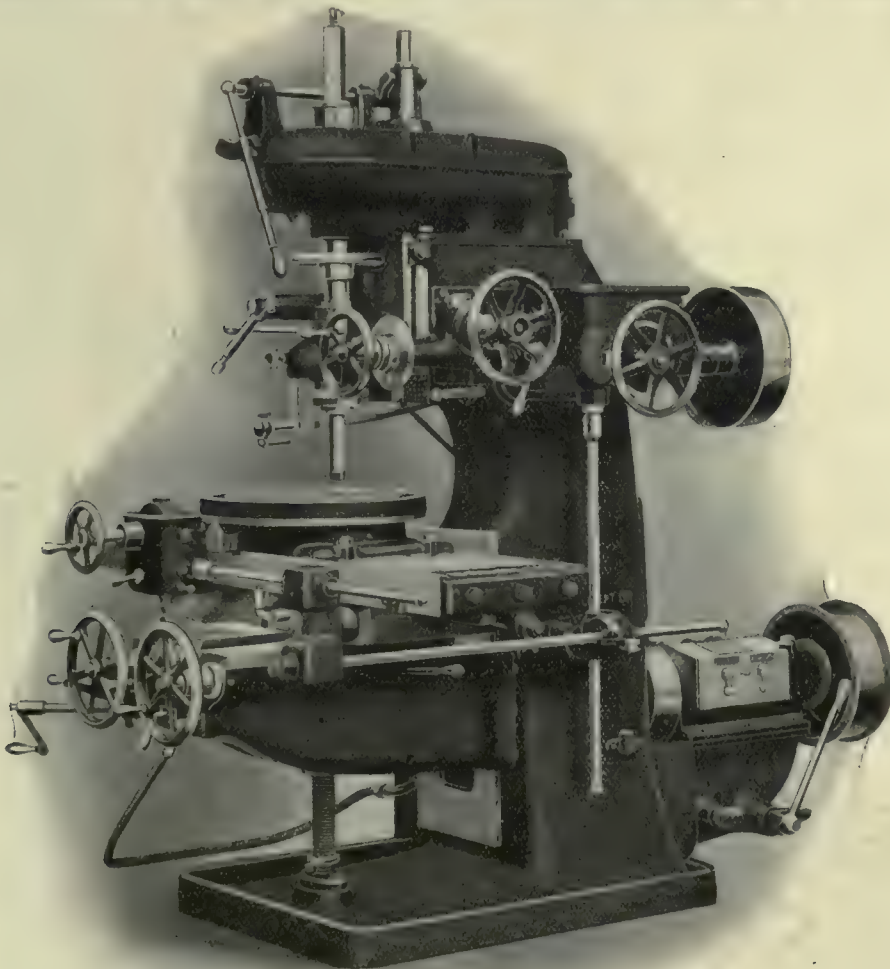

Fig. 3.—Recent Design of Vertical Milling Machine.

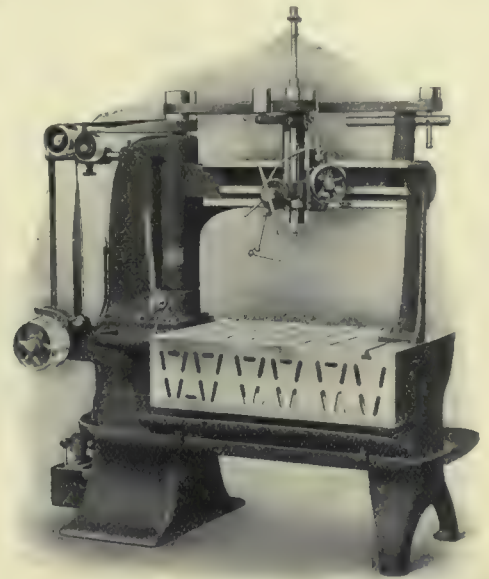

Fig. 4.—Ball Bearing Radical Radial Drilling Machine.

very quickly detached if it is desired to use the main table for long work.

Fig. 4 shows Herbert's patent ball bearing radial drilling machine, designed for drilling holes up to 1-inch diameter. The spindle, countershaft, and all idler pulleys run on single-track, dust-proof, oil-tight, ball bearings, and the spindle may therefore be run at very high speeds without wear or heating. No lubrication is necessary as the bearings will run for twelve months without attention. Owing to the high speeds that can be obtained, it is possible to run small drills made of high speed steel at their most efficient speed, which is not possible on the machines of the ordinary type. The advantage of the radial arm will be appreciated, as it enables large work to be bolted to

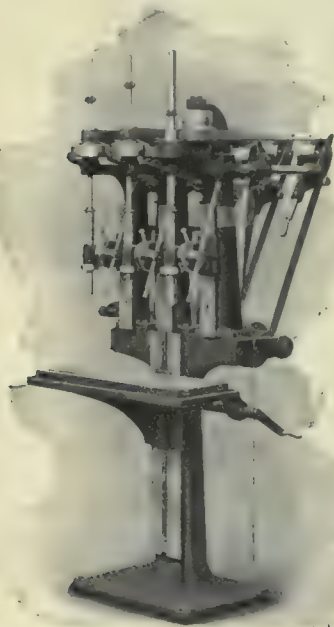

Fig. 5.—Ball Bearing Drilling Machine.

the table, and holes drilled in any part. It is found in practice that this type of machine will handle a large proportion of the work usually done on the ordinary geared radial drilling machine, and do it considerably cheaper.

Fig. 5 shows the upright type of Herbert's ball bearing drilling machine, which is built with one, two, three or four spindles. Any of the machines can also be fitted with a special geared spindle, as shown by the illustration, the advantage of the latter being that without sacrificing any of the advantages of the ball bearing construction, it enables holes up to 2-inch to be bored; tapping up to $\frac{3}{4}$ -inch Whitworth can be done, and bosses can be conveniently faced. Fitted to multiple spindle drills, the geared spindle makes the machine capable of dealing with a much larger variety of work than is usual with this type of drill.

Fig. 6 shows Herbert's 9-inch centre capstan lathe for chucking work. This

machine has a 3 $\frac{3}{8}$ -inch hole through the spindle, automatic feed to the capstan of 18 inches, and a saddle having automatic sliding and surfacing feeds. The machine is fitted with a patent chasing motion by means of which internal or external threads can be rapidly cut by means of a chasing tool.

This type of machine is employed for the finishing of castings, forgings, or blanks sawn from the bar, and is large-

can be mounted on an adjustable base behind the machine as shown by the illustration. The turret is hexagonal, and has the various tools attached to its faces.

The patent roller steady turner is shown in more detail in Fig. 8. It will be observed that the cutter is of simple form, which can be ground up from a rectangular bar of steel without forging or machining, and is therefore very

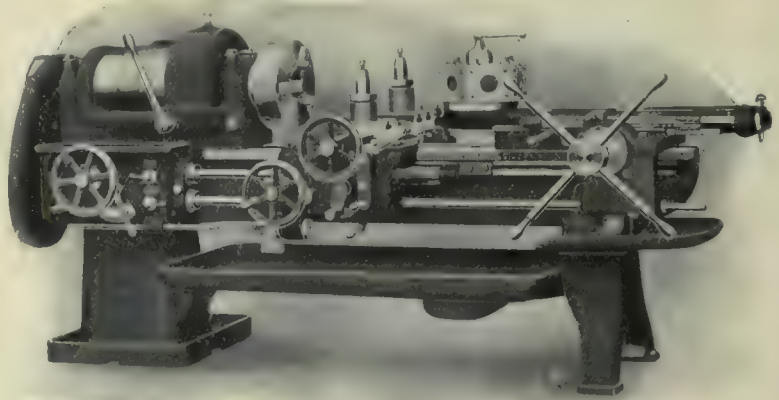

Fig. 6.—Centre Capstan Lathe for Chucking Work.

ly used on gear blanks, bushes, sleeves, pistons, and similar work found in petrol motors. There are nine rates of automatic feed to the sliding and surfacing motion in the saddle, and eighteen rates of automatic feed to the capstan, any desired feed being obtained instantly by rotating the hand wheel seen on feed box. This makes the machine suitable for a great variety of work. The drive is through extra large

cheap to make and maintain. The cutter is carried in a steel holder which is advanced or withdrawn from the work by means of the handles shown, the position of the cutter being controlled by means of a stop screw. This stop is very sensitive in its action, and enables the cutter to be withdrawn and returned to its exact position any number of times. The rollers, which take the pressure off the cut are carried on

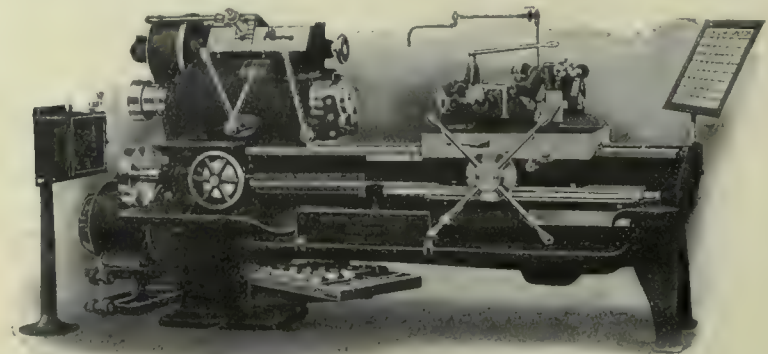

Fig. 7.—Hexagon Turret Lathe.

cone pulley and double gearing operated by friction clutches.

Bar Working Turret Lathe.

One of the machines to which Herberts have devoted considerable attention is the bar working turret lathe. Fig. 7 shows the 2 $\frac{1}{4}$ -inch x 30-inch patent hexagon turret lathe. The machine is fitted with constant speed drive through single pulley, giving 16 speeds to the spindle in either direction. This makes it very convenient for driving, as any type of constant speed motor

pins supported on each side, which is absolutely essential when heavy work is to be done, the pressure of the cut tending to keep the roller firmly on the work, and obviate any tendency to cant. The rollers with their slides can be quickly withdrawn from the work and returned to the exact position previously occupied.

With this patent roller steady turner the limit of output is with the cutter itself, the following being a recorded test:

Reducing a mild steel black bar of 30 ton steel from 1½-in. to ¾-in. diameter at one cut.

Revs. per minute 470
Feed in inches per minute 23½ in.
Lbs. of metal removed per min. 8.8

The automatic turning machine, by means of which detached pieces such as

chines engaged in finishing gear blanks, wheel naves, back and front hubs, differential boxes, brake drums, and similar work. Several machines are attended to by one operator so that the labor cost of the product is naturally very low. The machines are automatic in all the operations except in the

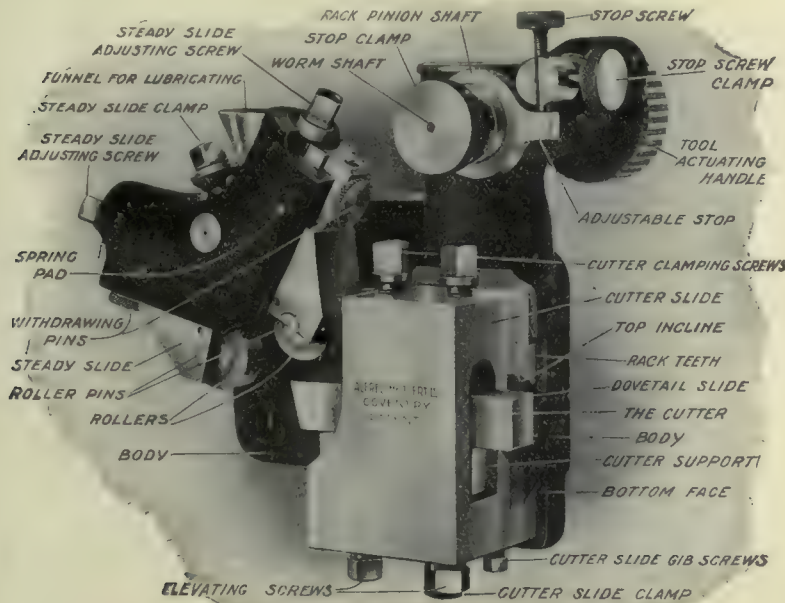

Fig. 8.—Roller Steady Turner.

castings and forgings may be machined in the most economical manner has recently received a considerable amount of attention on the part of Alfred Herbert. At Daimler Co.'s works at Coventry, where the new Silent Knight Engine is now being produced in large quantities, are twelve of Alfred Herbert's No. 6 automatic turning ma-

chines, which is done by hand in the usual manner. The machine is then started up and performs its cycle of operations and stops. The operator then removes the finished work from the chuck, replaces it with a fresh casting or forging and starts the machine up as before.

Catalogues

Babbitt Metals—Is the title of a small vest-pocket sized 4-page booklet gotten out by Factory Products, Toronto, and gives a short description of the nine different babbitt metals that they handle, as well as giving their varied uses. Among the kinds listed, users should be in a position to select a suitable metal.

Geometric Die Head—"Geometric Screw Cutting Die Head, Self-Opening and Adjustable Style D," is the title of a neat 16-page brochure issued by The Geometric Tool Co., New Haven, Conn., descriptive of this small tool. The construction is dealt with in detail and its use exemplified.

Coal Punchers—Form No. 5002 from the Ingersoll-Rand Co., New York, is a 24 page pamphlet descriptive of the New Ingersoll Coal Punchers, showing it in detail, and illustrating its operation in service.

Core Drills—The Davis Calyx Diamondless Core Drill is described at length in Form No. 9001, issued by the Ingersoll-Rand Co., New York. The pamphlet, which contains 48 pages gives many illustrations of the uses to which

this drill can be put, and shows the results in several cases.

Dart Unions—Under the significant title "Dart Unions; What They Are, and What They Do," the Dart Union Co., Toronto, have just issued a small eight-page booklet descriptive of these unions. Their essential points are: an all bronze ball joint; heavy iron thread ends; and neat finished castings and full threads. Dart unions are made in both screwed (or nut) and flange types, and may be used on steam, water, gas or air pipes. The ball-shaped seats make a perfect joint either in or out of line; the bronze face prevents corrosion and rust; their heavy construction adds length of life; and the Dart has all the advantages of the all-bronze union with the additional strength of iron ends. Dart unions claim the advantages of saving in upkeep cost; elimination of trouble in making joints; assurance of tight joints, allowing joints to be made innumerable times without expense; and also allow the joints as well as the pipes to be covered. Every Dart union and flange is guaranteed. Several colored illustrations of both screwed and flanged unions give a good idea of what these goods are like.

Fire Brick and Refractory Material—In catalogue No. 2, issued by the Detroit Foundry Supply Co., Detroit, its line of fire brick and refractory material for foundry use is illustrated and described. Numerous valuable tables are included which will aid the foundryman in lining his cupola, and tables of temperatures, weights, etc., are all given.

Smooth-On Instruction Book—The Smooth-On Mfg. Co., Jersey City, N. J., has issued the ninth edition of its instruction book, which is replete with information regarding the use of Smooth-On products. This book contains 96 pages, is well illustrated, and many views are shown of the application of iron cements, sheet packings, etc., made by this concern.

Horizontal Boring Machines—Webster & Bennett, Ltd., Coventry, England, devote section E of their Modern Machine Tool catalogue series, to this kind of machine, describing and briefly enumerating the principal points of a large number. It is a 16-page booklet, and numerous types of horizontal boring and milling machines are shown.

Book Reviews

Work, Wages, and Profit and Their Influence on the cost of Living—By H. S. Gantt, published by the Engineering Magazine, New York; size 5x7½ ins.; pages 194; illustrations 2; bound in cloth, price \$2.

This book, written by an authority who has been connected with advanced work in labor management, deals with the possibilities of increasing production by scientifically training the workmen. Until within a few years, the mechanic was necessarily the source and conservator of all industrial knowledge, and on him, therefore vested the responsibility for training workmen. With the advent of the scientifically educated engineer, capable of substituting a scientific solution of problems for the empirical solution accepted by the mechanic, the responsibility of training workers naturally shifts to the shoulders of the engineer. If he accepts this responsibility, and bases training on the results of scientific investigation, the efficiency of the workman can be so greatly increased that the manufacturer can afford to give those that take advantage of this training, such compensation as will secure their hearty and continuous co-operation, thus making permanent advance toward the solution of the labor problem. The foregoing, is in substance the basis of the book. Most of the information contained is from various addresses delivered by the author before scientific bodies, and also from a series of articles published early this year in the Engineering Magazine. Dealing first with the application of the scientific method to the labor problem, the author proceeds to a discourse on the utilization of labor. Compensation of workmen is next discussed, dealing with day work, piece work, and task work with a bonus. Training workmen in habits of industry and co-operation and fixing these habits, is dealt with at length, with a final chapter on profits and their influence on the cost of living. To managers, superintendents, and foremen who are interested in business building, this book ought to be of especial interest.

FOUNDRIY PRACTICE AND EQUIPMENT

Practical Articles for Canadian Foundrymen and Pattern Makers, and
News of Foundrymen's and Allied Associations. Contributions Invited.

IRON CASTINGS: DEFECTS AND REMEDIES.*

By Robert Job.**

To many consumers an iron casting is an iron casting, and little thought or attention is given to its quality, apart from a general surface examination, to see whether it appears to be sound and if it is clean and of the desired dimensions.

In some cases, the casting must be machined prior to use, and the serious



Fig. 1.—

defect may develop that the iron is so hard as to turn the edge of the tool, or make the work of machining so slow that labor costs are high. If the casting cannot be machined, it must be rejected and delay occurs in getting replacement; and even when it can be slowly machined and finally gets into service, difficulty soon begins, for a casting of this type, though having a high tensile strength, is unfortunately brittle and fragile under impact, and, as a consequence, failure is apt to occur after a short service.

The cause of such hardness is generally excess either of sulphur or of manganese, due to defective quality of the cupola charge, that is to say, of the pig iron, or scrap, or coke, one or all. In some cases also the silicon is too low for the character of the casting. Sometimes, too, the moulding sand has been improperly tempered and the iron has been chilled, or, again, perhaps a poor grade or an excessive proportion of scrap has been used in the charge.

From this brief statement it will be evident that "hard iron" is not by any means a result of any one cause, but may be due to many widely differing conditions.

In order to find the proper remedy, the cause of the difficulty must, of course, be determined. Often an analysis of the iron will tell the story, or

again, in some cases the physical condition of the casting will give the clue by pretense and appearance of blow-holes, shrinkage-cracks and other characteristic defects.

If the hardness is caused by excess of sulphur or by otherwise incorrect composition, the inference is that proper care has not been used in the selection of the material, and purchase should be made under carefully arranged specifications, fixing the proportion of silicon, phosphorus, sulphur, and carbon to accord with the properties desired in the castings. For instance, if tough, strong easily machined iron is desired, the silicon, sulphur, phosphorus, and manganese should be limited and the quality of the coke should be carefully investigated in order to hold down the proportions of sulphur and of ash, for obviously it is a sheer waste of time and money to pay great attention to the quality of the pig iron and then accept and use shipments of coke which may contain thirty times as much sulphur as is present in ever a poor grade of pig iron. Under such conditions nothing but hard castings may be expected.

Sponge Iron.

Porous, spongy iron is another source of annoyance and loss to the consumer. Frequently a great deal of work will

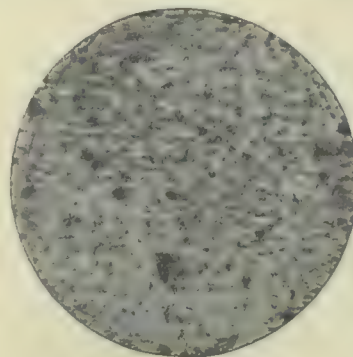

Fig. 2.—

be put upon a casting in the machine shop, only to have a large cavity finally develop, rendering the casting unsafe for the service intended. In such case, replacement must be made by the foundry, but the labor is lost and the delay which occurs in replacement often causes great inconvenience. Frequently the surface of the casting shows no indication of this defective condition.

Porosity is frequently due to blow-holes in the iron, as for instance, when gas has been trapped in the casting owing to failure to provide proper vents. In some cases, the iron may not have been fluid enough when poured into the mold, and in consequence, the

small bubbles of gas could not escape before solidification occurred, and an unsound, honey-combed casting is the result.

Every foundryman knows well the importance of "hot iron"—that is to say, iron which is at such a high temperature when poured into the ladle it is almost as fluid as water. Such iron fills the molds thoroughly, and many of the foundry troubles which otherwise are apt to result are avoided. To secure it, one must pay special attention to the cupola charge. A sufficient proportion of coke must be used, and its quality must be carefully regulated. The proportion of sulphur and of ash must be low, and dust and small pieces which would tend to check the draught and thus prevent free-burning must be absent. A sufficient air pressure must be maintained, and the cupola practice so regulated that a quick melt will be secured. Other things being equal, the shorter the time in the cupola, the better the chance to get good castings.

Shrinkage Holes.

Shrinkage holes or cracks are apt to occur with hard, high sulphur iron, and this condition due simply to the fact that iron of this character contracts to a much greater extent than does a softer iron containing a large proportion of graphitic carbon. Shrinkage holes are a fruitful cause of failure, and they are particularly objectionable owing to the fact that they frequently do not appear upon the surface, and hence the weakness may not be suspected until failure occurs. The remedy for such condition, obviously, is to keep at a minimum the proportion of sulphur in each constituent of the foundry charge, and take proper precautions to keep the iron soft.

Typical Defects.

Defects of castings are, unfortunately, of so many varieties that any attempt



Fig. 3.—

to cover the subject even in a brief description, would weary your patience, and I have, therefore, confined myself to

* Read before Canadian Railway Club, Montreal.

** Vice-Pres. Milton Hersey Co., Montreal.

a few of the typical cases which are seen all too often in service. "Strong as iron" is an axiom, but frequently the appearance of the metal belies the truth. As an instance of this, we have in mind, a heavy, massive cast iron base weighing many tons which supported a large shop tool. After a short service cracks began to develop, necessitating the removal of the tool and the replacement of the base.

A careful investigation was made to determine the cause of failure and it was found that the proportion of phosphorus and of silicon in the iron were excessive, causing the metal to be exceedingly weak, and hence resulting in fracture. High phosphorus is particularly objectionable when the casting is subjected to impact, as for instance, in wheel-centres, cylinders, columns, etc., and unluckily for the consumer such iron can generally be obtained at a considerably lower cost than can a stronger, tougher, grade, and consequently, unless each shipment is systematically tested before use the better quality cannot be expected. Many cases have come under our observation in which wheel-centres and cylinders containing about one per cent. of phosphorus have cracked after a service of only a few weeks,

or even days, while with the phosphorus reduced to about one-half of one per cent. and with the other elements properly proportioned the castings would give good service for years under the same conditions.

In cylinders, radiators, and other castings, a very close texture is essential in order to avoid leakage. Often there is little or no indication to the eye that holes exist in the iron, and yet under test the pressure gauge falls, showing that the iron is porous. Such character may be due to the presence of slag and oxide in the casting, or, in other words, the continuity of the iron may be broken up by fine particles of foreign matter. This condition may be caused by over-blowing the iron in the cupola, or it may result from the impurities in the scrap, and in order to remove it thorough deoxidation is essential.

From what has been said, it will be readily understood that radical differences exist in the structure of the metal of castings, and within recent years great strides have been taken in the development and microscopic study of the characteristic forms, and it has become possible to identify many causes of diffi-

culty by the appearance of polished or etched sections cut from the castings. As examples, we will, in closing, throw upon the screen a few photo-micrographs, the originals being magnified fifty diameters—showing typical forms which may make or mar the service. All of the sections were cut from the sides of automobile cylinders where the metal was about one-quarter inch thick. The metal is polished, but not etched.

Figure 1 shows a very open structure with large areas of graphite. A structure of this kind is relatively weak, and not well adapted to withstand impacts.

In Figure 2 the iron is porous and contains considerable oxidized metal, a consequence of defective foundry practice.

In Figure 3 the metal as a whole has a close texture, and is strong and well adapted for the service intended. The iron is largely free from slag and oxides and the graphite, although present in even larger proportion than in Figure 1, is distributed in fine lines throughout the metal, greatly increasing the strength. The analysis of this iron showed that the constituents had been carefully selected, and its structure proves that correct methods of foundry practice have been used.

A Young President of a Large Malleable Industry

The Smith's Falls Malleable Castings Company Elect New Officers—Description of their Plant, Including their New Foundry.

With the rapid industrial growth of Canada the younger men are coming to the front and assuming the positions of responsibility and trust formerly occupied by those more advanced in years. This was demonstrated at the recent annual meeting of the Smith's Falls Malleable Castings Co., Smith's Falls, when Ebenezer Theodore Frost, second son of W. H. Frost, was elected president and treasurer.

E. Theodore Frost, who succeeds his father, who now occupies the position of vice-president and general manager, has been connected with the company

for several years. He received his education at the Smith's Falls public and high schools, but soon left these institutions to obtain his education in the broader field of life's experience.

He spent some time in the banking business and afterwards entered the office of the Malleable Co. He worked diligently at the business until he was familiar with every detail including the buying and selling. Thus at twenty-five he has qualified himself for the controlling of a large institution employing between three and four hundred men. E. T. Frost is also a director and treasurer

of the Smith's Falls Electric Power Co.

Thirty-two years ago W. H. Frost and Charles Jones conceived the idea that they could find a good demand for malleable castings if a suitable place could be procured. They started with a capital of \$2,500 in a small brick building 30x60 ft., situated on the water front. At first they employed one molder in addition to themselves and built a one ton oven. They were then ready for business.

Their first order was for 75 cents, but others came quickly, and they were compelled to erect larger buildings. For



No. 1 Plant of Smith's Falls Malleable Castings Co.

this purpose they bought in the surrounding land along the river front until they have in that part of the town about 2½ acres almost completely housed in.

In 1903 the company was incorporat-



EBENEZER THEODORE FROST.

President and Treasurer of the Smith's Falls Malleable Castings Co.

ed, but was still in control of W. H. Frost until this year when E. T. Frost was elected president.

Plant No. 1.

The larger plant is situated on the the Rideau River and is connected to the C.P.R. by a siding. This plant consists of one large building 360x90 ft.

a core room 40x60 ft., sand sheds, etc.

In the annealing room are two double annealing oven with a capacity of 160 tons, 2 single of 40 tons, and 3 single of 20 tons capacity. In the foundry are two 15 ton air blast furnaces. The

left of the illustration is at the power plant, the centre at the annealing ovens and the one at the left is at the foundry furnace.

Officers.

At the recent annual meeting the fol-



W. H. FROST.

Vice-Pres. and General Manager S. F. Malleable Castings Co.



J. EDWIN FROST.

Secretary S. F. Malleable Castings Co.

total capacity of the No. 1 plant is 5,000 tons per year.

In the power plant is a 75 h.p. E. Leonard engine. The coal supply is brought by water from Sodus Point. The coal is mined at Westmoreland, Pa., and 4,000 tons are required annually.

Plant No. 2.

The illustration shows the No. 2 plant which is almost wholly devoted to railroad work, the specialty of the company being railroad castings though large quantities of automobile and agricultural castings are also turned out.

The No. 2 plant, located on a ten-acre plot in the north end of the town, is L-shaped, all the departments being under one roof. The main wing is 91x220 and contains the annealing room and foundry, core room, etc., while the other wing 91x70 ft, contains the shipping room, power plant, etc.

Coal is brought from Westmoreland by rail and a C.P.R. siding facilitates the receiving of supplies and shipping of castings. Over 2,000 tons coal are required yearly at the No. 2 plant.

In the power plant is a 60 h.p. Inglis engine which drives 8 tumbling barrels, suction fan, blower, and wood-working lathe. Chapman double ball bearings have been installed throughout.

The capacity of the No. 2 plant is 3,000 tons per year. The furnace has a 15-ton capacity and there are two 40-ton annealing ovens. The stack at the

following officers were elected :

Ebenezer Theodore Frost, President and Treasurer.

William H. Frost, Vice-President and General Manager.

J. Edwin Frost, Secretary.

Directors—E. T. Frost, W. H. Frost, B. H. Frost, J. E. Frost and Henry Kirkland.



H. H. KIRKLAND.

General Supt. S. F. Malleable Castings Co.

in which is housed the annealing room, rumbling room, shipping room and power plant; a foundry and pattern shop 250x60 ft. with a wing 125x60 ft.,



BURTON H. FROST.

Director S. F. Malleable Castings Co.

The general superintendent is Henry Kirkland. The assistant superintendent is Walter Stewart, who is in charge of the No. 2 plant.

Improvements Contemplated.

In order to make conditions better for the men in No. 1 plant, a heat ex-

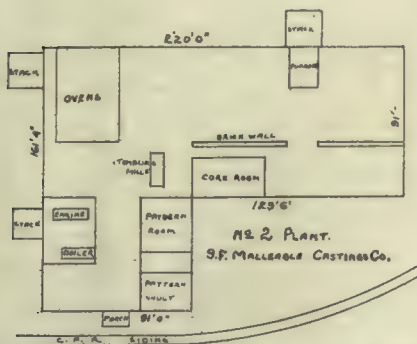

No. 2 Plant of Smith's Falls Malleable Castings Co.

hauster will be installed. Waste heat from the furnace will be used to heat the building in winter and the heat and gases will be exhausted to atmosphere in the summer.

The offices of the company are at No. 1 plant. A convenient site has been purchased at the corner of Water and Bay Sts., and large new offices will be erected. Other improvements include a complete new power plant. Eleven additional acres have been purchased on the river front about a mile east of No. 1 plant and it is expected that a large new industry will soon be erected on this situation.

RUPERT G. BRUCE CO.

On another page appears an adv. of a new firm just organized in Canada with headquarters at Toronto, of particular interest to the foundry and electro-plating trades. The manager, Rupert G. Bruce, who has been associated with Frederic B. Stevens, organized this firm to manufacture in Canada a lot of material that up to the present time has been imported exclusively from the United States and England.

The new organization has taken out a charter under the name of Rupert G. Bruce Co., Limited, and have located their factory at 96-98 Queen St. East, with a large warehouse for raw materials at the head of Macdonell Ave. on the C. P. R.

They will manufacture foundry supplies, also electro-platers' supplies, buffing compositions and cotton buffs.

Their superintendent is a man of very wide experience, having been in this line for the last 25 years in the different parts of the United States.

The directors of the new firm are Charles S. Murray, of the W. A. Murray Co., and R. L. Kleiser of the Albert Kleiser Co., Frank C. Foy, of the New York Central Railway, and Rupert G. Bruce.



No. 1 Plant S. F. Malleable Castings Co., Showing Molding shop and Annealing Room.

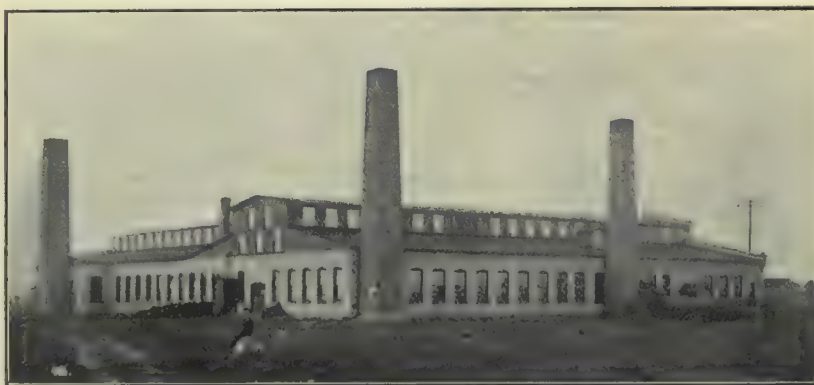

Plant No. 2 Showing New Foundry of Smith's Falls Malleable Castings Co.

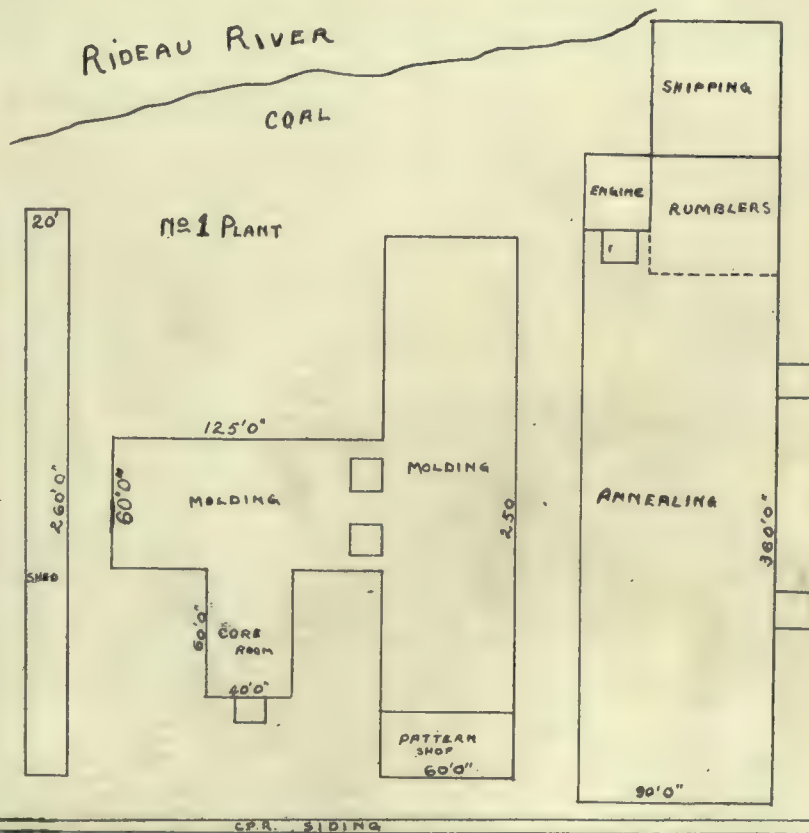

Plant No. 1.—Smith's Falls Malleable Castings Co.

INDUSTRIAL ^A_N^D CONSTRUCTION NEWS

Establishment or Enlargement of Factories, Mills, Power Plants, Etc.; Construction of Railways, Bridges, Etc.; Municipal Undertakings; Mining News.

Foundry and Machine Shop.

WELLAND.—United Motors, Ltd., will build an automobile factory in the township of Crowland. The directors of this concern are Frederick Sager, Detroit; E. A. English, Toronto; W. L. Adams, Niagara Falls; and L. C. Raymond, and B. J. McCormick, of Welland. The capitalization is \$200,000. The construction of the proposed works will be commenced at an early date.

MONTREAL.—A. H. Huff, sales manager, J. L. Waldie, secretary-treasurer, and F. Moseley, superintendent of the pipe mill of the Montreal Rolling Mills, have resigned, and will establish a rolling mill to manufacture iron pipe.

MEDICINE HAT.—The Alberta Iron Rolling Mills will erect a \$100,000 plant.

OTTAWA.—A. W. Henderson, of Bruton, Somerset, Eng., has secured a site on McKay Street, 100 x 155 feet, as the location for his patent saw factory.

PRINCE RUPERT.—The Grand Trunk Pacific Railway Co. will erect at Prince Rupert a dry dock with a lifting capacity of 20,000 tons at a cost of \$1,500,000, and a marine depot at a cost of \$200,000.

COLLINGWOOD.—Major J. A. Currie intends to establish a screw and bolt factory here. A two-storey mill building will be erected at once, and \$50,000 will be expended on plant and machinery. From 80 to 100 men will be employed when the works are in operation.

HAMILTON.—The Hamilton Bridge Works Co. have taken out a permit for the erection of an addition to their factory here, to cost \$10,000.

ORILLIA.—The contract for the office and main building of the Canada Smelting & Refining Company's plant, has been awarded to E. Webb.

PORT HOPE.—The International Tool Steel Co. have definitely decided to locate at Port Hope, and will at once commence the erection of four buildings. Fifty men will be employed at the start and \$35,000 will be expended on machinery and plant. Twenty furnaces will be installed at first, to be increased to fifty later on.

SAULT STE. MARIE.—The directors of the Lake Superior Corporation have decided to expend the sum of \$12,000,000 during the present year on extensions to the steel plant, railway construction, as well as on the company's mines and forests.

ST. BONIFACE.—The C.N.R. is reported to have completed arrangements with the Council of the city of St. Boniface, Man., for extensive improvements there within the next two years, including a large roundhouse, storehouses, coal warehouses, freight sheds, the union depot to be shared with the G.T.P., and a new traffic bridge to be built across the Red River from Winnipeg. The total improvements will cost over \$1,000,000, and the company has signed a bond guaranteeing the completion of the work within two years.

HAMILTON.—The Canadian Westinghouse Co., Hamilton, has arranged for another addition to its plant, and will build a brick and reinforced concrete extension to its detail building, and a fire hall at a cost of \$22,000.

LONDON.—The Willys-Overland Co., Toledo, O., automobile manufacturers, will establish a Canadian branch at London, having secured a factory building on Dundas St., which is being remodelled in accordance with its plans.

PETERBORO.—The Lundy Shovel & Tool Co. will locate a new plant here.

WATFORD, ONT.—The Andrews Wire & Iron Co. will erect a plant here.

MIDLAND.—Fire broke out in the foundry of the Midland Engine Works Co., recently, damag-

ing the south side of the building and contents. The loss is estimated at \$12,000, with an insurance of \$10,000.

CAMPBELLTON, N.B.—The I.C.R. Board of Management has decided on the plans for extensive new railway buildings to replace those destroyed by the fire of last July. The total cost will be about \$200,000.

TORONTO.—The C. A. Dunham Co., Marshalltown, Iowa, with offices in the Continental Life Bldg., propose erecting a plant here for the manufacture of heating and power plant specialties. The building will be 40 x 80 ft. and will cost \$11,000.

SMITH'S FALLS.—Negotiations are being carried on to consolidate the malleable casting industries in Smith's Falls, St. Catharines, Galt, Brantford and Walkerville.

LONDON.—Geo White & Sons expect to be in their new plant this month. The machine shops are 350 x 142 ft., shipping room is 250 ft. square, the separator dept. 200 x 100 and the office 120 x 40. Hydro-electric power will be used. The shops are located on the C.P.R. and G.T.R.

LONDON.—The C.P.R. has purchased the land between Quebec and Elias Sts. and will erect a new roundhouse and machine shop. The roundhouse will accommodate 25 locomotives, and modern coal chutes, ash pits, etc., will be erected. The machine shop will be up-to-date in every respect.

BELLEVILLE.—The roundhouse which is being erected by the Grand Trunk here is the second largest on the system, having stalls for 42 locomotives. It is of concrete, and a quarter of a mile in circumference. The walls are 19 feet high, 22 inches thick at bottom, and nine inches at the top. The roof is of steel, covered with asbestos. A new machine shop, 50 by 200 feet; office and storeroom, 30 by 80 feet, are also being erected. The work, on which 350 men are employed, was begun on August 10, and is expected to be completed by Nov. 1.

MONTREAL.—Plans and specifications for the new building to be erected for the National Acme Mfg. Co., Ontario Street east, may be seen in the office of Mr. E. L. Baugh, 107 St. James Street.

WALKERVILLE.—The general contract for the 3-storey, 80 by 90 feet, factory for the Ford Motor Car Co., has been awarded to Wells & Gray Co., Toronto; cost \$21,000. Albert Kahn & E. Wilby, Detroit, Mich., architects.

PRESTON, ONT.—Clare Bros. & Co. intend to enlarge their factory considerably, the adjoining property having been purchased. Work may not start until next spring.

PRESTON.—A by-law to give certain privileges to Bartz Bros., formerly of Galt, will be submitted to the ratepayers on October 10th. A large factory will be erected.

NEW WESTMINSTER.—Work has been started on the wire nail factory, to be erected for G. W. Laidlaw, formerly of Hamilton, Ont. It is being built about a half a mile below the Lulu Island bridge, inside the city limits. About one hundred men will be employed. Wire nails and fencing will be manufactured at present, but a galvanizing plant will probably be added next year.

CALEDONIA.—The Paris Plaster Co. are spending \$50,000 on their works.

BERLIN.—A new industry, the Dominion Shoe & Slipper Co. is locating here.

WELLAND.—The Hamilton Tube Co., which came from Pittsburg to Hamilton two years

ago, and manufactures butt joint, welded and structural tubing, have decided to locate here.

HAMILTON.—The Hamilton Bridge Works Co. announce the purchase of ten acres of land in the manufacturers' annex, for an open air stock yard. A ten-ton traveling crane will be built and switches from the G.T.R. and T.H. & B. run in. The plant will cost \$10,000, and if the company's business warrants it, an extension of the west end plant will be built there.

MONTREAL.—Two prominent English firms will shortly locate branches here. The George Anderson Co., manufacturers of cranes and stove machinery, will build a large factory at once, and expect to occupy it by May 1. They also expect to build shops in some western Ontario town. The second concern is the Cleveland Bridge & Engineering Co., of Darlington, England, which will locate shops here.

VANCOUVER.—A. D. McRae, of the Canadian Northern, announced to-day that car building shops for the entire system with 5,000 men employed will be erected at Port Mann.

ST. JOHN, N.B.—George McAvity, president of T. McAvity & Sons, Ltd., said that his firm would establish a large iron or brass foundry in Port Arthur, Ont., to take care of the firm's western business. It is also probable that they will establish a branch of the large St. John works in Montreal.

WALLACEBURG.—The Wallaceburg Brass Works, which has been carrying on business in the town hall property for the past four years, intends erecting a permanent factory in the near future, provided the town gives some concessions. The concern now employs 60 hands and will require 100 when the new factory is completed. The board of trade has recommended that the company be granted a fixed assessment of \$5,000 for ten years for school taxes, exemption from other rates, and if a town waterworks is established, free water for the same period. A by-law to this effect will be submitted to the electors in January.

KINGSTON.—The organization has been completed for the Hawthorn Silver Iron Mines to develop iron ores around the K. & P. R. The company has 20,000 acres, will ship ore and manufacture pig iron. A plant with a capacity of 2,000 tons will be built.

LONDON.—The McClary Mfg. have taken out a permit for a one-storey concrete building on Adelaide Street, to cost \$5,000.

The Cleveland Bridge and Engineering Co., of Darlington, Eng., are considering the erection of a large plant here in the near future.

GUELPH.—The Gilson Mfg. Co. has commenced work on the erection of an addition, 100 x 60, doubling the size of its present plant.

CHATHAM.—The International Harvester Co., Chicago, have secured control of the Chatham Wagon Co., and intend to extend the plant considerably.

MONTREAL.—The general contract for the erection of the extensive shops of the Street Railway Co. has been awarded to J. B. Pauze & Co.

WINNIPEG.—The C.N.R. have a permit to construct coach shops in the west yard, at \$42,000. The contract has been let to the Carter-Halls-Aldinger Co.

EDISON, ALTA.—The contract for the construction of roundhouses, machine shops, and passenger station here, the first divisional point on the G.T.P. west of Edmonton, has been awarded to the May Construction Co., at a price approximating \$75,000. Work is to be commenced at once on the new buildings.

Municipal Undertakings.

WINNIPEG.—The City Council last night let the contract for forty-six thousand feet of cable for the power plant transmission to the Canadian-British Insulated Cable Co., of Montreal. The price was \$51,500.

TORONTO.—The F. H. McGuigan Construction Company, of Toronto was awarded the contract for the construction of the Queen Street East high level bridge at \$193,000.

PRINCE ALBERT.—A by-law will be voted on to expend \$12,000 for a filtration plant.

VERDUN, QUE.—The town council will extend its water dyke, at an expenditure of \$200,000.

SOURIS.—The J. L. White Co., of Sioux Falls, S.D., will install a waterworks system.

MEDICINE HAT.—Proposes replacing all wood pipes by iron pipes in its waterworks and sewerage systems.

ST. CATHARINES.—Engineer Kennedy has submitted a report for the improvement and extension of the waterworks at a cost of \$52,000.

FERNIE.—A by-law will be submitted to raise \$27,000 for the construction of a sanitary sewer east of Crow's Nest Southern Railway.

MONTREAL.—Tenders addressed to L. N. Senecal, secretary, Montreal Board of Commissioners, will be received for steel pipe, dredging work and concrete pier in connection with the new intake for the waterworks.

MEDICINE HAT, ALTA.—The ratepayers have approved by-laws to raise \$50,000 for the installation of an electrical plant, \$45,000 for waterworks extension and \$18,500 for industrial sites.

DAUPHIN, MAN.—The contract for putting in the waterworks and sewerage system was awarded to Flanagan & Murphy. The cost of the system will be \$250,000. Wood pipe will be used for the gravity system, which is nine miles from the Riding mountains to the town.

Orillia.—At a recent meeting of the council it was decided to spend immediately \$10,000 in improving the power plant. A by-law will be submitted to the ratepayers asking them to authorize the expenditure. The installation of a new unit and greater wheel capacity must, however, follow within a year or two, and this will entail a probable expenditure of from \$25,000 to \$30,000.

MEDICINE HAT, ALTA.—The city recently invited tenders for two d.c. gas-engine-driven 125 k.w. alternating current units for the power plant. The following bids were received:—Gorman, Clancy, Grindley, generator, \$5,675; Canada Foundry Co., engine and generators, \$21,050; Canadian Fairbanks Co., engine \$13,922, generators, \$5,903; National Meter Co., engines, \$13,495, generators, \$6,500; Turner, Fricke, Pittsburg, engines, \$16,706.80, generators, \$7,851; Chapman, Walker, Co., engines, \$17,060, generators, \$5,630; Drummond, McCall & Co., engines, \$13,500; E. Leonard & Sons, engines, \$13,974, generators, \$11,100; Kilmer, Pullen & Burnham (1) engines, \$14,500, generators \$8,776, (2) engines, \$17,500, generators, \$8,776; Siemens Bros., (1) engines, \$14,500, generators, \$4,255, (2) engines, \$17,500, generators, \$4,255; Allis-Chalmers-Bullock, Ltd., engines and generators, \$24,215; Canadian Westinghouse Co., engines, \$20,600, generators, \$5,690; Canadian Boving Co., (1) engines, \$14,500, generators, \$4,255, (2) engines, \$17,500, generators, \$4,255; Vandeleur & Nichols, (1) engines, \$14,500, generators, \$3,050, (2) engines, \$17,500, generators, \$3,200.

REGINA, SASK.—Six money by-laws, authorizing the issue of debentures totalling \$196,000, were carried recently. The money will be distributed in the following improvements:—Pavements, \$132,000; fire protection, \$16,000; sewer and waterworks extension, \$20,000; sidewalks, \$59,000.

OTTAWA.—The cost of the scheme to get the city water from McGregor's Lake, in the Gatineau District, some 12 miles north of the city, is placed at approximately \$2,000,000. The by-law for this may be submitted to the ratepayers at the next election.

WHITE METAL
PRESSURE DIE
NO MACHINE WORK NECESSARY—WRITE FOR FACTS
LUMEN BEARING CO., TORONTO

BETTER RESULTS AT LOWER COST

can be secured for any class of castings by arranging your mixtures by analysis. Years of practical experience in foundry work are at your service when you consult with

The Toronto Testing Laboratory, Limited

18 SATURDAY NIGHT BUILDING, TORONTO

EXPERT FOUNDRYMEN, METALLURGISTS, CHEMISTS

TESTS OF METALS, FUELS, CORES, OILS, Etc., AT REASONABLE PRICES.

**BEST
LEATHER
BELT
MADE**

TORONTO MONTREAL WINNIPEG
St. JOHN, N.B. VANCOUVER

Simplified Stills for Industrial Alcohol

We are builders of portable stills. We build and install plants large or small. 5 to 500 gallons, and we solicit trade of those who fully recognize the value of safety. Our FOOL PROOF SAFETY STILL is a still that an unskilled laborer can operate after one day's instruction. This is our small 5-gallon still.

We have features in our SIMPLIFIED STILLS that place them far ahead of other stills for speed, efficiency, simplicity in setting up, and cheapness of operation in the production of industrial alcohol from shavings, old or green sawdust, and vegetable waste, at a cost of from 8 to 12 cents per gallon.

Brought down to dollars and cents, a 5-gallon tax-free still, capacity 20 to 25 gallons daily, 26 days in a month, at say 20 gallons a day—520 gallons, price 50c. per gallon, = \$260.00. Less cost of labor, fuel and material, say 12c. per gallon, or \$62.40. Net monthly profit, \$197.60. This is the way the 5-gallon still figures out. The cost of the 5 gallon tax-free still complete and ready to set up is \$135.00. Freight prepaid if cash accompanies order.

If the said 5-gallon Tax-free Still fails to produce alcohol at a cost of 12c. per gallon or less, we will cheerfully return to you the money paid us.

75 to 100 gallon plants, installed under guarantee, cost \$950.00, payable as follows: \$500.00 with order and \$450.00 in sixty days.

One ton of corn at the price of 40c. per bushel will cost \$14.25; coal cost, labor, etc., to convert one ton of corn into alcohol will cost \$6.40; total, \$20.68, less value of slop of \$11.60 per ton of corn, making net cost of material \$9.08 per ton. One ton of corn will yield 98 gallons of 188 degree alcohol at a cost of \$9.08, or \$0.0916 per gallon. This is from official statistics.

Do you know that there is a trust in stills? We know we can save you money and seek to prove it. Won't you kindly consider our proposition when we SHOW YOU IN DOLLARS AND CENTS just what our stills will do for you? May we hear from you to-day—now?

Yours very truly,

THE WOOD WASTE DISTILLERIES CO. Inc., 1204 McColloch St., Wheeling, W. Va.

Side Head of the Vertical Turret Lathe

A Big Factor in Reducing the Cost of Production of Many Kinds of Face Plate Work.

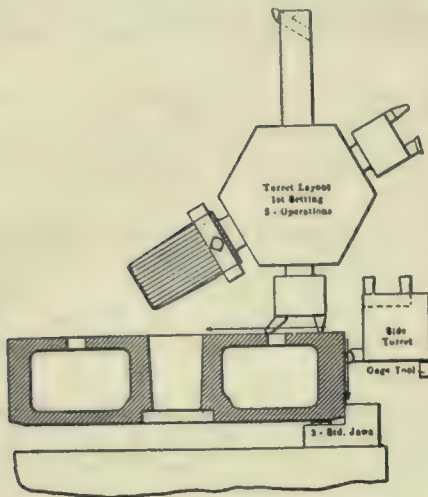

First Setting, First Operation.

Perhaps the greatest productive difference between modern and pre-modern machine tools is the doubling up or "tripling" up of cutting tools. One cut at a time is no longer sufficient to get competition-meeting results, and it was the realization of this fact that led to the designing of the Bullard Vertical Turret Lathe.

Besides the main turret head this machine has a side head which enables the operator to take simultaneous cuts on various surfaces. It does not interfere in any way with the operation of the main head.

The illustration herewith shows a job on which the Vertical Turret Lathe made a new record of 90 min.

The piece is a 27½ in. piston on which simultaneous cuts with the Side Head cut 30 minutes from the best previous time.

The Vertical Turret Lathe has two heads—a turret head and a side head—which allow two or more tools to be used at the same time.

All the tools needed for a whole series of operations are held in instant readiness.

In a word the Vertical Turret Lathe is a unique combination of the good points, the advantages of the vertical boring mill and the horizontal turret lathe.

Its vertical construction allows many a piece to be finished before it could be chucked ready for work on a horizontal turret lathe. For modern work—especially for duplicate pieces—the Bullard Vertical Turret Lathe is an innovation. It is a tool you must know about.

The entire sequence of operations on the piece shown here and other pieces is graphically illustrated in our new catalogue, which is free for the asking. Send for catalogue C-15.

The Bullard Machine Tool Co.
Bridgeport, Conn., U.S.A.

WELLAND.—The ratepayers will again vote on a by-law for waterworks extensions. The total net of the proposed scheme is \$52,000, and include the following items: Plunger pumps, etc., \$41,000; waterwheels, \$2,300; cast iron pipe, \$9,100. Wm. Kennedy, Jr., is the consulting engineer.

NEW WESTMINSTER.—The Municipal Construction Co., Vancouver, has secured the contract for laying the new steel main to Coquitlam Lake which will supply water here and to the municipality of Richmond. The 25 inch pipe line will be fourteen miles in length and is calculated to discharge 250,000 gallons of water every 24 hours. There is already a 14 inch main tapping the lake connecting with two reservoirs in the city, the high level one being at an elevation of 410 feet, and the low level one at 250 feet. The tender price for hauling and laying the new line is 125,000, and the total cost to the city \$360,000.

Electrical Notes.

ST. THOMAS.—At the meeting of the council, Alderman Price and Alderman Chant were authorized to continue the negotiations with Port Stanley in regard to the furnishing of that municipality with power.

STELLARTON, N.S.—The Acadia Coal Co., Stellarton, N.S., are contemplating the installation of a 2,200 kilowatt electric plant at what is known as the Allan Shaft in Stellarton, to be used in driving their machinery and for general lifting purposes. Should the plan mature this will prove the largest electric plant east of Halifax.

ST. THOMAS.—The tender of the Canadian General Electric Co. for supplying new transformers and purchasing 132 old ones for the local hydro-electric distributing plant was accepted, it being the most favorable of three others. The amount involved is about \$15,000.

PORT CREDIT.—William Stewart has secured the contract for the erection of the transformer station of the Hydro-Electric Power Commission. The contract price is \$14,000.

OTTAWA.—The civic commission has awarded the following contracts for the new conduit from the power station in Hull to the distributing station on Laurier Avenue: For transformers, Canadian General Electric Co., \$12,000; cable, British Insulated Cable Co., Montreal, \$16,246; conduit pipe, Eadie-Douglas Co., \$2,704; man-hole covers, J. B. Maclaren, Ottawa, 2½ cents per pound for cast iron, and \$35 per ton for rails.

BERLIN.—The formal test at the Hydro-Electric Commission's transformer station made recently was satisfactory. The town is the first in Canada to have its streets illuminated with electric power generated at Niagara Falls and conveyed over the municipality owned and operated transmission lines. The power comes here at from 110,000 to 130,000 volts to the transformer station, where it is stepped down to 13,200 volts, to the town's plant where it is again transformed to suit local conditions—550 volts for street railway purposes and 500 for the street arc lights.

MONTREAL.—A second power station of the Shawinigan Water and Power Co. will be situated near the present generating plant at Shawinigan Falls, on the St. Maurice river, about 85 miles from Montreal, and will be designed for a capacity of 75,000 horsepower, as against 55,000 horse power in the case of the existing station. The company's transmission lines, which are of aluminum carried on wooden poles, exceed a total of 400 miles. For transmission to Montreal the current, which is generated at 2,200 volts, is transformed up to 50,000 volts; 3,000 horsepower is supplied to the Montreal Street railways, and 15,000 horsepower to the Montreal Light, Heat and Power Co. The Shawinigan company supply 25,000 horsepower of water power—undeveloped—to the Northern Aluminium Co., and 14,000 horsepower of water power to the Belgo-Canadian Pulp and Paper Co.

JOHN J. GARTSHORE
83 Front St. W., Toronto

RAILS and SUPPLIES
New and Second-hand
For RAILWAYS, TRAMWAYS, Etc.
Old Material Bought and Sold.

OPAL GLASS TILING
FOR WALLS OF
MACHINERY AND POWER HOUSES
Most approved material.
TORONTO PLATE GLASS IMPORTING CO'Y
PLATE AND WINDOW GLASS
135 to 143 Victoria St., - Toronto



**Oil Tempered
Steel
Springs**

—for every purpose
and the best for each
use.

—Special styles of
all kinds to order.

**THE CLEVELAND
WIRE SPRING CO.**
Cleveland, Ohio.

**STEELGRETE
EXPANDED METAL**

**REINFORCEMENT FOR CONCRETE FLOORS
and ROOFS.**

The most reliable bond for all varieties
of concrete slab.

WRITE FOR HAND BOOK AND SAMPLES

Competent Engineering staff in charge
of construction.

Expanded Metal & Fireproofing Co., Limited
100 King Street West, TORONTO

**MAPLE LEAF
STITCHED COTTON DUCK
BELTING**
DOMINION BELTING CO. LTD.
HAMILTON CANADA

New Companies.

British Columbia Portland Cement Co., Princeton, B.C.; capital, \$500,000; to manufacture cement. Incorporators, R. P. McLennan, Vancouver; L. W. Shatford, Hedley, and Reuben Cross, Spokane, Wash.

The Dorchester Peat Co., London; capital, \$75,000; to manufacture peat fuel. Incorporators, John McWilliams, J. M. McEvoy, London, and Jas. McLean, Dorchester.

The Dominion Stove and Foundry Co., Penetanguishene; capital, \$250,000; to establish a foundry for manufacturing stoves of every description, furnaces, boilers and other heating apparatus. Incorporation has been granted by the Ontario Government. The provisional directors are Chas. Beck, D. A. Lahey, C. E. Wright, Chas. McGibbon and Dr. P. A. McDonald, all of Penetang.

Edward Partington Pulp and Paper Co., St. John; capital, \$950,000. The company will control the A. Cushing and company sawmills as well as the present large pulp mill.

Canadian Materials Co., Montreal; capital, \$50,000, to manufacture railway supplies and general supplies of every class. Incorporators, Pearl Robert Diamond, Thomas Allen Hays.

The Modern Power Co., Winnipeg; capital \$25,000. Directors, William Lloyd Williams, and Victor Clark Parker, both of Winnipeg.

Winnipeg Steel Culvert Co., Winnipeg; capital, \$60,000. Directors, Percy S. Joel, Cecil L. Hamilton, and Roy T. Picard.

The Ivel Motor Co., Winnipeg; capital \$300,000. Incorporators, James S. Stewart and Edmund L. Taylor.

Canadian Railway Materials Co., Montreal; capital \$50,000. Incorporators, Pearl R. Diamond, Wm. P. Robertson and Darley Burley-Smith, all of Montreal.

Montreal Hydro-Electric Co., Ltd., Montreal; capital, \$10,000,000; to carry on the business of an electric light, heat and power company in all its branches.

Wilson Auto Co., Ltd., Montreal, capital, \$50,000; to manufacture steam and other engines, agricultural implements, boiler makers, and conveyances of every description, iron founders, electro platers. Incorporators, Louis Athanase, and Henry Johnson Elliott.

Building Operations.

MONTREAL.—Canada Sugar Refining Co., a factory on St. Patrick Street, \$18,000; Piper Light & Heat Co., an establishment on St. Remi Street, St. Henri, \$18,000, and Jas. Robertson, a factory on Shannon Street, \$5,500, are industrial permits granted recently.

TORONTO.—Ideal Woman's Wear Co., alterations to factory, 662 and 664 King Street W., \$15,000, and the Robert Simpson Co., wagon, storage and harness shop, Dalhousie Street, \$53,000, are recent factory permits granted.

MONTREAL.—The Canadian Rubber Co. will erect a five-storey steel and concrete building as an addition to their plant.

MONTREAL.—The Catholic School Board have taken out a permit for the erection of a new school on Visitation Street, to cost \$105,000.

CALGARY.—\$61,000 will be spent for new exhibition buildings.

SASKATOON.—The proposed hospital extensions will cost about \$108,000.

LETHBRIDGE.—The ratepayers passed a by-law to spend \$75,000 to build another new school.

SUMAS, B.C.—A large brewing company is soon to commence the erection of a \$150,000 brewery.

HALIFAX.—The Halifax Cold Storage Co. have awarded a contract for erection of a new warehouse building on Lower Water Street, to L. B. Fader, and H. R. Silver & Co. They are also having a storehouse erected on Upper Water Street.

Castings

**TOUGH, STRONG, GREY
IRON CASTINGS, EASILY
MACHINED.**

Any size up to ten tons

Wm. Hamilton Co., Ltd.
PETERBORO, ONT.

Russell Machine Co.
MACHINE TOOL
AND
DIE MAKERS

First-class Workmanship

Prices Right

Estimates Furnished to the Trade

Russell Machine Co.
St. Catharines, Ont.

In making Pipe connections always use

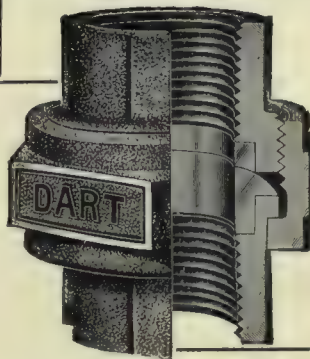
**Dart Unions**

No packing required. As shown in the cut, the two sections of a Dart Union are brought together in the form of a ball joint. Each section is bronze seated. So that Dart Unions make a Bronze-to-Bronze Ball Joint that simply cannot leak. Joints can be made with great speed, even if pipes are out of alignment.

YOUR DEALER SHOULD
SELL THEM. ASK HIM.

Dart Union Co., Limited

93-97 Niagara Street, TORONTO, ONT.

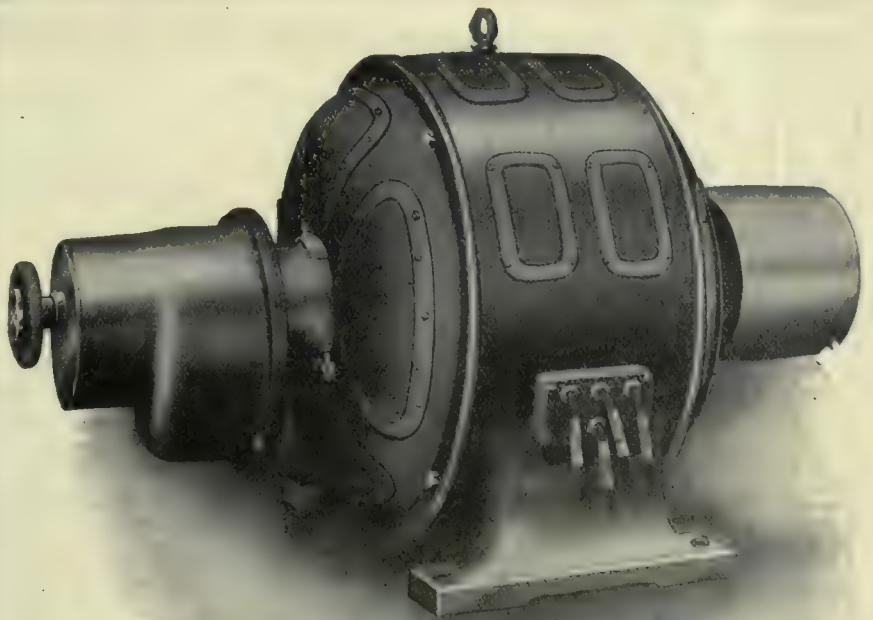

BRUCE PEEBLES' Standard Protected Type

La Cour Converters

A.C. and D.C. Motors and Dynamos

Turbo Generators

Sole
Canadian Agents

VANDELEUR & NICHOLS Dineen Building
TORONTO

MALLEABLE IRON CASTINGS

PRATT & LETCHWORTH CO.

BRANTFORD ONTARIO

ALUMINIUM

"The 20th Century Metal"

Lightest and most adaptable of the industrial metals. Fills a hundred purposes where the ordinary metals fail. Saves its cost over and over again by its lightness and easy working qualities

You can now get your Aluminium requirements promptly attended to by our clients, The British Aluminium Co., Limited, of

INGOTS, BARS, SHEETS, RODS, ANGLES, ALLOYS, NOTCHED BARS, CORNICES, WIRE, CHANNELS, ETC.

London, the largest producers in the United Kingdom.

Sole Agents for Canada: Parke & Leith, 205 Yonge Street (Bank of Toronto Building) - - - Toronto.

To-day get Bulletin "D" on the varied uses of ALUMINIUM (Parke & Leith)

JESSOP'S Best Tool Steel

"ARK" High-Speed Steel

THE FAVORITE BRANDS WITH USERS OF GOOD STEEL.
A LARGE ASSORTMENT OF SIZES IN STOCK.
JESSOP'S HIGH-GRADE FILES AND RASPS.

80 Bay St., Toronto, Ontario
Chas. L. Bailey, Agent.

Reid-Newfoundland Company
St. John's, Newfoundland.

Jas. Robertson Co., Ltd.
Montreal, Quebec

Jas. Robertson Co., Ltd.,
St. John, New Brunswick

WM. JESSOP & SONS, Limited, Manufactory, SHEFFIELD, ENGLAND.

LUBRICATION AND SUPERHEAT

The greater use of superheated steam is making modern lubrication more difficult. You no doubt realize this yourself. In the event of trouble, however, we want to suggest to you

DIXON'S FLAKE GRAPHITE

which, unlike oil or grease, is entirely unaffected by any degree of superheat.

Engineers from all over the country write and tell us that Dixon's Flake Graphite solves their lubrication troubles experienced with superheated steam.

We would be glad to send you free trial sample by No., 223-C.

JOSEPH DIXON CRUCIBLE CO.

JERSEY CITY, N.J.

CALGARY.—The excavation for the new \$100,000 I.O.O.F. building, has been commenced.

TORONTO.—The Nasmith Co., will erect a two-storey factory here, to cost \$60,000.

WINNIPEG.—Stobart & Sons have secured a permit to erect a factory to cost \$45,000.

BROCKVILLE.—The Canada Carriage Co. is erecting a building at a cost of \$10,000, for the manufacture of automobiles.

MONTREAL.—Messrs. Jas. Robertson & Co., are erecting a factory building on Shannon St.

MONTREAL.—Messrs. H. L. Piper & Co., are erecting a three storey factory building on St. Remi Street.

NEW WESTMINSTER.—The B. C. Packers' Association of Vancouver, are contemplating the erection of a \$40,000 addition to their plant here.

Planing Mill News.

ALBERNI, B.C.—The recently formed merger of four of the largest lumber companies in this province, known as the Canadian Pacific Lumber Co. (capital, \$5,000,000), it is stated, will erect at New Alberni a large mill upon the completion of the E. & N. Railway extension from Nanaimo. The following companies are included: Canadian Pacific Lumber Co., of Port Moody, the Barkley Sound Cedar Co., of Port Alberni, the Anglo-American Lumber Co., Vancouver, and the Gibbons Lumber Mills, Arrow Lakes.

MONTREAL.—Fire broke out in the planing mills of H. Mathieu & Co., 14 St. Charles Borromeo Street, recently. The loss was not heavy.

OWEN SOUND.—The McDonald-Rowland Lumber Co. have recently purchased the sawmill and equipment in the town of Gore Bay, Manitoulin Island, formerly owned by Mr. Brett.

ST. JOHN, N.B.—The Cushing sawmill property has been purchased by the Edward Partington Pulp & Paper Co. H. W. Schofield is secretary-treasurer of the purchasing concern. The mill will be used in connection with their pulp manufacturing business.

MONTREAL.—Hodgson's Lumber Mill and 400,000 feet of lumber were burned at Como on the Ottawa River yesterday, causing a loss of \$50,000, with only \$20,000 insurance.

VANCOUVER.—An important timber deal is reported from Prince Rupert, the vendor being A. F. Sutherland, of Vancouver, who has sold to a syndicate of British and Canadian capitalists headed by W. Gamble, barrister, of Ottawa, ninety-three timber limits for \$490,000. The timber is on the Naas and Kitsumkalum rivers, and is said to be of excellent quality, comprising red cedar, spruce, larch and pine of high grade. It is presumed that the new company intends to take advantage of the opening up of Northern British Columbia, by erecting a sawmill in the vicinity of Prince Rupert.

POWELL RIVER, B.C.—M. J. Scanlan, of the Brooks-Scanlon Lumber Co., of Minneapolis, states that the plant of the Powell River Paper Co., at Powell River, will be completed, and in operation by July 1 next. Invested in the enterprise will be about two million dollars, and the payroll of the company will be about \$500,000 per year. The buildings are being made of reinforced concrete, and about one thousand men are engaged in construction work at the present time. Newspaper and wrapping paper will be the first products of the company, but later the finest grades for commercial use will be produced. The market of the company will be in the Orient, Australia, New Zealand and along the Pacific Coast of this continent.

TRENTON.—The cooperage mills here were destroyed by fire on the 8th inst. Loss, \$15,000.

COMO, QUE.—Hodgson's lumber mill and 400,000 feet of lumber were destroyed by fire on the 14th inst. Loss, \$50,000.

GRANBY, QUE.—The sash and door factory owned by M. Bruneau was destroyed by fire on the 18th inst. Loss about \$50,000.

NEW WESTMINSTER.—The Walsh Sash & Door Factory are planning the erection of a large factory, with a capacity of 1,000 feet per

SPECIAL MACHINERY, Etc.

ARMSTRONG BROS.

16 Sheppard St., Toronto
Mfrs. of SPECIAL MACHINERY
Patents Perfected
GEAR CUTTING, TOOLS, DIES, ETC.
Ruching and Pleating Machinery.

ERNEST SCOTT

91 BLEURY ST., - MONTREAL

Machinist and Tool-maker

Dies for sheet metal work. Stampings and light manufacturing. Special machinery designed and made to order.

**The PARMENTER BULLOCH CO., Ltd.
GANANOQUE, ONT.**

Iron and Copper Rivets, Iron and Copper Burrs Bifurcated and Tubular Rivets, Wire Nails, Copper and Steel Boat and Canoe Nails, Escutcheon Pins, Leather Shoe and Overshoe Buckles, Fellow Plates.

OWEN SOUND IRON WORKS, LIMITED

OWEN SOUND, ONT.

Cement Mill Machinery, Boiler and Steel Tank Work of all kinds, Grey Iron and Brass Castings

PATTERNS AND MODELS

**PATTERNS
IN WOOD**

~ ALL KINDS ~

Difficult Core Work a Specialty
High Grade - Right Prices - Prompt Delivery
SATISFACTORY WORK GUARANTEED

THE HAMILTON PATTERN WORKS
258 CATHERINE STREET NORTH
HAMILTON, ONT.

PATTERNS
FOR

ALL KINDS OF MACHINE
WORK MADE IN
WOOD, BRASS
WHITE METAL OR IRON

by the very highest class of skilled mechanics.

Only the highest grade of material used in our work. We can handle your pattern work to your complete satisfaction.

Let us quote prices.

TORONTO PATTERN WORKS
87 Jarvis St., Toronto, Canada

day. A small sawmill will be operated in connection.

AYLMER, P.Q.—Bailey's lumber mill was destroyed by fire last month at a loss of \$10,000. The cause of the fire is attributed to incendiarism.

BLACKVILLE, N.B.—McLaggan Bros.' sawmill was destroyed by fire last month. The mill was equipped with rotary, shingle and lath machines, and the loss is estimated at about \$10,000, with no insurance.

GRACEFIELD, P.Q.—Messrs. Campbell & Stearns have purchased the limit belonging to Charles Lowe, and have started building operations on a sawmill at that town, which will cost in the neighborhood of \$35,000.

WOODSTOCK.—The Canadian Lumberman Machine Co., a branch of an industry established at Muskegon, Mich., capitalized at \$105,000, has decided to locate here. It will manufacture dovetail, glue and jointing machines for making scrap ends of lumber into full-sized boards. The machines cost about \$4,000 each.

SAULT STE. MARIE.—Recent incorporations include the Stone Lumber Co., Limited, with a capital of \$100,000. The incorporators include John A. McPhail and S. G. Stoné, both of Sault Ste. Marie, Ont.

FORT FRANCES.—The Fort Frances Lumber Company's sawmill, together with three cars of lumber, was destroyed by fire last month at an estimated loss of \$60,000. The fire is attributed to a spark from a locomotive.

BERTHIER, QUE.—Fire caused \$30,000 loss to Mr. J. D. Chenard's saw mills.

Trade Notes.

HAMILTON.—The London Machine Tool Co., Hamilton, have received the following orders for the Western Drydock Co.: 5-60" punch, 2-48" shears, 1-60" x 60" planer and 1-18' x 10" lathe, all motor driven.

GALT.—The Goldie-McCulloch Co. report the following large order for the new Springfield shors of the G.T.P., at Winnipeg:—3-750 h.p. cross compound Corliss engines, to be direct-connected to 500 k.w. generators; 1-375 h.p. single cylinder Corliss to be direct-connected to 1-250 k.w. generator; and 1-225 h.p. engine, to be direct-connected to a 150 k.w. generator, all of these to run at 150 r.p.m. For the 75 k.w. exciters, 2-11 x 12 side crank Ideal engines are being supplied. In addition, they have an order from the town of Weyburn, Sask., for the new municipal electric plant including 1-15 x 30 x 30 cross compound Corliss, to be direct-connected to 1-250 k.w. generator, and 10 and 17 x 15 condenser. In addition there is the piping and steel smoke stack.

MONTREAL.—The British Insulated Cable Co. have recently closed two very large orders, one with the city of Ottawa and the other with the City of Winnipeg, for the entire supply of transmission cable in connection with their municipal systems.

MONTREAL.—In the construction of the new Windsor Station it was necessary to provide for the safe and rapid transfer of both passengers and baggage from floor to floor. As the building will be 200 ft. or more high and of immense area, this meant the installation of a large number of elevators, and the C.P.R. has just awarded the contract to the John McDougall Caledonian Iron Works, and they will be built in Montreal. They include eight passenger, two baggage and one kitchen or freight elevator and constitute the largest single elevator contract ever awarded in Canada. These eleven elevators will be of the hydraulic plunger type. In the early history of the elevator business it was considered that plunger elevators, though highly desirable in many respects, were impracticable for lofty buildings. The elevators were designed by Thure Larsen, of Worcester, Mass., formerly chief engineer of the Plunger Elevator Co. and afterwards of the Standard Plunger Elevator Co.

**ONE MAN
can cut threads on 6-in. pipe with a
"BEAVER"
ADJUSTABLE DIE STOCK**



No. 6, threading 1-4, 3-8, 1-2, 3-4 in. complete. No changing of Dies or Bushings.



No. 25B, 1 in. to 2 in., R.H. complete.

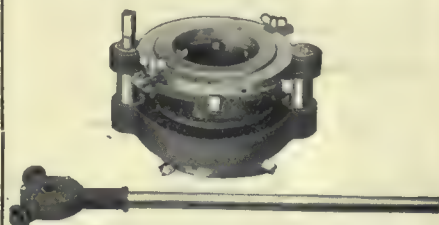

No. 60, cuts 2½, 3, 3½, 4, 4½, 5, and 6 inch pipe

NOTE—That with the three tools shown above you can thread from 1-4 in. to 6 in. pipe. No loose parts.



No. 41, cuts 2½, 3, 3½ and 4 in. pipe.



"WARREN" DIE STOCK

(Non-receding dies—adjustable.)

Each stock cuts two sizes. Made in four sizes.

Prices \$5.00, \$5.50, \$6.00 and \$7.00.

THEY SAVE TIME AND MONEY

Write for our Illustrated List

Borden-Canadian Co.
Richmond St. East, Toronto, Ont.

When writing advertisers kindly mention having seen the advertisement in this paper.

THE BEYER WATCHMAN'S PORTABLE CLOCK

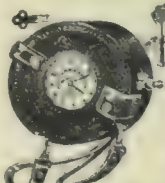

IS TAMPER PROOF and thoroughly reliable

Shall we send Particulars?

G. C. BREDIN, Sales Agent
252 Dundas St. London, Canada
Record Dials furnished for all machines.

STAMPINGS Special Manufacturing to Order

No matter how hard a stamping problem you put up to us, the chances are we can satisfy you. Many people use stampings in place of castings and find them more satisfactory and often cheaper. Send blue prints and samples and let us quote you.

The Silent Partner is an interesting little magazine. We send it free—when there's a reason

THE GLOBE MACHINE & STAMPING CO.
899 Hamilton Street, Cleveland, O.

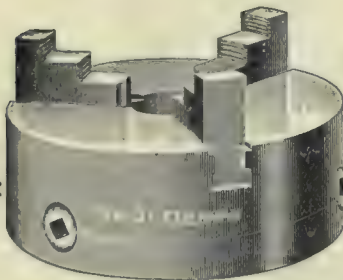

"CUSHMAN" CHUCKS

For general machinists' use. Strong and durable and designed for hard service.

Our catalogue shows many styles and sizes and is sent free.

The Cushman Chuck Co.
Hartford, Conn., U.S.A.
Established 1862



The John McDougall Caledonian Iron Works Co., Limited, have made arrangements with Mr. Larsen for the exclusive use of his patents and inventions in Canada, and he is now at the Windsor Hotel preparing plans.

DRUMMONDVILLE, P.Q.—Joseph A. Gosselin has received patent papers for a steam engine slide valve through Marion & Marion, patent attorneys, Montreal.

HAMILTON.—The Smart-Turner Machine Co., Ltd., report the following recent pump orders: E. Long Mfg. Co., Orillia; T. J. McOutcheon, Dunnville; James Cornhill, Chatham; Randolph McDonald Co., Norwood; Evans Co., Sudbury; Monarch Knitting Co., Dunnville; Mr. Nairn, Bartonville, Ont.; St. Joseph's Convent, Toronto; Niagara Trand Spray Co., Burlington, Ont.; Great Lakes Dredging Co., Port Arthur; Ontario Iron and Steel Co., Welland; and S. C. Allen, Alliston, Ont. The pumps are of various kinds.

MONTREAL.—The Jeffrey Mfg. Co., office and works, corner Cote and Lagachetiere Streets, Montreal, also having a Toronto office formerly in the Dineen Bldg., 8 Temperance Street, has removed the Toronto office to more commodious quarters at 174 King Street East. Mr. H. W. Scott, mechanical engineer, formerly connected with the home office of this company in Columbus, O., is now in charge of the Montreal office and works. The Jeffrey Mfg. Co. are an old established concern, making a specialty of elevating and conveying apparatus for handling all kinds of materials in lumber camps, mines, quarries, as well as conveying apparatus for handling materials from the docks, loading to vessels. New machinery has been installed at the Montreal works for more economical production. This company also has nearly 100 branch offices situated in the leading commercial centres all over the world.

POWELL RIVER.—The Powell River Paper Co. have awarded a contract to the John McDougall Caledonian Iron Works Co., Montreal, for 11 Worthington Centrifugal pumps varying in size from 3 inches to 12 inches at the discharge outlet. Two of these pumps, each having a capacity of 4,200 gallons per minute and driven by electric motors, will carry ground wood stock from the grinders to the screens. Two others, having a capacity of 4,000 gallons per minute each, and direct connected to water wheels, will carry ground wood stock to deckers. The remaining pumps will be used in connection with bearers and digesters and for boiler feed and general purposes. These 11 pumps will have an aggregate capacity of 37,000,000 gallons daily, which is nearly equal to that of the city of Montreal water department, and will be built in the works of the company on William St. The Powell River Paper Co. is backed chiefly by Minneapolis capitalists, and the mill is now being erected on the Powell River, a few miles from Vancouver, B.C.

Standard Engineering Co. Secure Large Contract.

The Provincial Steel Co., Cobourg, are making considerable enlargements to their rail mill and will install a new rail mill and a continuous steel heating furnace with a daily capacity of 100 tons of rails and other shapes. The contract for this equipment has been placed with the Standard Engineering Co., 47 Wellington St. East, Toronto.

Large New Cedar Mill.

The Western Canadian Lumber Co. is starting to erect a new mill exclusively for cedar, just east of its present big plant at Millside, New Westminster. This large company, which has recently been formed, has at its head such well-

known financial men as Col. Davidson, A. D. McRae, Wm. Mackenzie, D. D. Mann and Edward Swift. The new plant will cost about \$300,000, and will have a capacity of 75,000 feet every ten hours. The planing mill, which is part of the new project, will have a capacity of 1,000 doors per day. Three hundred new hands will be employed, and it is expected that the planing mill and sash and door factory will be in operation within three months, and the cedar mill will be ready early next season.

Large Industry for Welland.

Negotiations have been concluded by which a million-dollar plant will be erected at Welland to employ 1,500 hands, by Deere & Co., Moline, Ill. The products of the Welland factories will be harvesters, waggons, plows, carriages, grain drills, harrows, disc harrows and other articles. The company will be granted no bonus, but have been promised a few concessions in respect to electric street railway, water, drainage, water service, etc. The capital of the company is \$40,000,000. Their plant at Moline is the largest of its kind in the world, employing 7,000 hands and shipping 50,000 carloads of machinery yearly.

Activity at Port Mann, B. C.

The officials of the C.N.R. are busy marking the boundaries of their new terminal townsite, Port Mann, on the Fraser River, opposite New Westminster. A wharf is to be constructed immediately where material for railway construction can be unloaded. The officials of the railway state that it is the intention of the company to offer every inducement to manufacturers, elevators and industrial enterprises generally, to locate at this point.

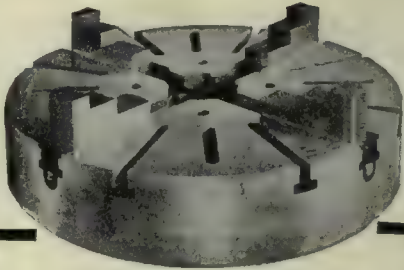

A UNIQUE OFFER!

We have not the slightest doubt in our own minds about the superiority of the

Imperial Chuck

and to introduce it to your shop, we are prepared to send you one—all charges paid—which you can use for 30 days. If it does not do all we claim for it, send it back AT OUR EXPENSE. But we know no test is too severe for the IMPERIAL CHUCK. Made in Canada.

SEND FOR CATALOGUE TODAY

Ker & Goodwin
Brantford, Canada

Expect to Install Elevators?



Jeffrey Bucket Elevators can be adapted to meet all practical conditions. They are the most dependable elevators built for handling coal, stone, ores, gravel, etc. They are moderate in first cost and require less for up-keep than any other elevator made.

Write for Catalog V8r and state your requirements.

The Jeffrey Mfg. Co.

Montreal Office and Works : Cor. Cote & LaSalle St.

Toronto Office : 174 King Street East

Main Office and Works : Columbus, Ohio.

Branch offices in all the leading commercial centres of the world.

BROWNING
 Locomotive Cranes
 Wrecking Cranes
 Lifting Magnets
 Automatic Buckets



Browning Double Truck Locomotive Crane with Lift Magnet unloading scrap iron from gondola car. We make complete installation of this kind. The cranes are also fitted to use an Automatic Bucket Steam Shovel, and Pile Driver attachments.

Write us for full particulars.

The Browning Engineering Co.
 Cleveland, : : Ohio



In some factories one of the greatest difficulties has been the bearings. It costs money to babbitt a bearing. The cost of re-babbiting is ten times the cost of the metal; therefore, every engineer and superintendent should use the best

**HARRIS
 HEAVY PRESSURE
 BEARING METAL**

will give perfect results on general machine bearings.

The Canada Metal Co.
 LIMITED
 TORONTO

Babbitt Metal Specialists

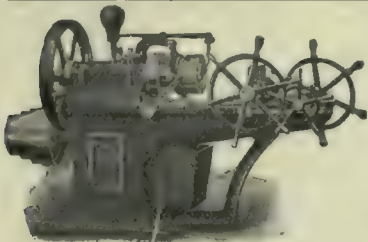

NEW AND UP-TO-DATE
BOLT AND NUT MACHINERY

INCLUDING
 Bolt Cutters, Nut Tappers, Bolt Headers, Upsetting and Forging Machines, Wire Nail and Spike Machines and Bulldozers.

Send for Catalogue M.
NATIONAL MACHINERY CO., Tiffin, Ohio, U.S.A.
 Canadian Agents: H. W. PETRIE, Toronto, Ont. WILLIAMS & WILSON, Montreal, Que.

High Grade Malleable Castings

of all sizes and kinds

Galt Malleable Iron Co., Limited - Galt, Ontario

Special Taps Special Dies Special Reamers

Unless you have special appliances, you can get these tools from us better and cheaper than you can make them.

We have the equipment and the experience. Ask us for prices.

A. B. JARDINE & CO.
HESPELER, ONT.

BENCH POWER PRESS

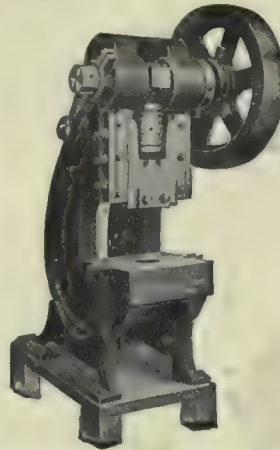

New Design

Particularly adapted for small, quick work, to take place of foot presses.

Write for Prices.

W. H. Banfield & Sons

MACHINISTS, DIE AND TOOL MAKERS
120 Adelaide Street West
TORONTO - - - CANADA

FILING CATALOGUES.

The article on "Filing Catalogues to Secure the Greatest Benefit," in the Business Management department of the September issue, was written for Canadian Machinery by Adam Smith, of the Office Specialty Co., Toronto, a specialist in factory filing systems.

LONDON MACHINE TOOL CO. ENLARGING

The London Machine Tool Co., Hamilton, have decided to increase the capacity of their plant by the installation of a number of special machines. Among the new machines, orders have been placed for special and standard high grade tools for the manufacture of interchangeable parts on standard machine tools. In connection with the extensions, the services of C. H. Overkamp, formerly of the Triumph Mfg. Co., and American Tool Works, have been secured as works manager.

Mr. Overkamp is familiar with the Canadian field. Recently he visited the works of the London Machine Tool Co., Hamilton, and was so impressed with prospects for business in Canada that he decided to throw in his lot with the above company. He is confident that Canada has a great future before it, and predicts that Canadian tool builders will, in the near future specialize in certain lines of manufacture.

C. H. Anderson, for the past five years with the Hans Renold Co. has joined the staff of John Millen & Sons, Montreal, to look after their sales for the Coventry Chain Co.

John W. Gerell, manager of the Toronto shipyards, which have been bought by the Polson Iron Works, Toronto, has accepted the position of manager of the Polson Iron Works.

Charles F. Kenworthy, until recently with the Engineering Department of the American Brass Co., and formerly of the Kenworthy Engineering Co., has been engaged by the Rockwell Furnace Co., to represent them in the New England States and Canada. Mr. Kenworthy has devoted his entire time for the past eighteen years to the design and construction of furnaces and fuel apparatus, and brings with him a large acquaintance among the builders and users of this line.

The British government has appointed Leonard P. Morgan, assistant smelter and refiner of the United States mint at Philadelphia to take charge of the new refinery at the Ottawa branch of the royal mint. Mr. Morgan must become a British subject.

"GLOBE" TIME RECORDERS



are made in Canada by expert mechanics. They are accurate, simple in construction, strong, and of good chaste appearance. They will record with absolute accuracy the arrival and departure of your employees (TO THE MINUTE), making you pay for what you get and no more. All lates and short time marked in red, regular time in green. The small cut at the top illustrates the WEEKLY MODEL, an entirely automatic recorder requiring no attention whatever during the week, as all changes, etc., occur automatically (DONE BY CLOCK WORK). The DAILY MODEL is shown in the cut at the bottom. This recorder is being used mostly in large shops, etc., where a large number of hands are employed. With the "GLOBE" TIME RECORDERS only one operation is required as against five with most others.

Inspection may be made through the glass sides of the case, but tampering with records is impossible, no danger of having soiled, torn or lost records when same are unfavorable, as is the case with all CARD CLOCKS. We are now manufacturing over 224 DIFFERENT TIME RECORDING CLOCKS, and are in a position to meet the requirements of any business. Write us about your needs and let us suggest what will best meet with your requirements. WE SOLICIT YOUR ENQUIRY.

able, as is the case with all CARD CLOCKS. We are now manufacturing over 224 DIFFERENT TIME RECORDING CLOCKS, and are in a position to meet the requirements of any business. Write us about your needs and let us suggest what will best meet with your requirements. WE SOLICIT YOUR ENQUIRY.

W. A. WOOD, Manufacturer

Head Office and Factory: 40 St. George St., Montreal

Branch Offices:

19 Bleury St., Montreal 65-67 Victoria St., Toronto

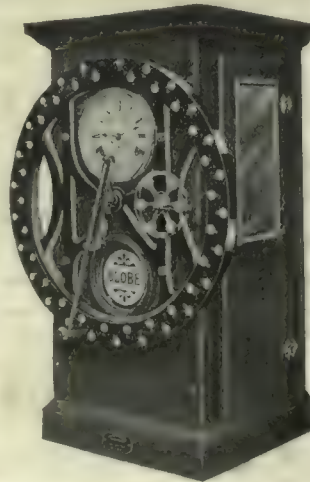



Fig. 1.—No. 1 of Panoramic View Showing Store Room.

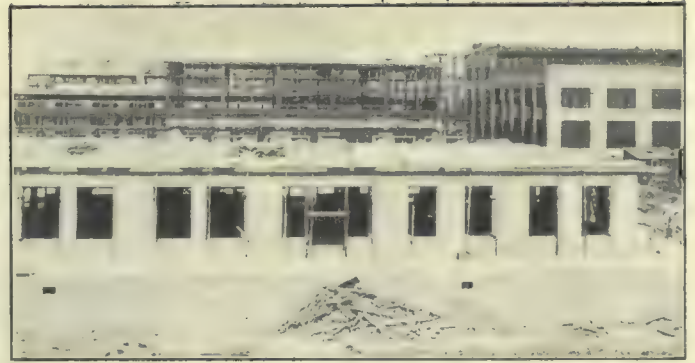

Fig. 2.—No. 2 of a Panoramic View Showing East End Stores with Pattern and Car Shops in Background.

Mammoth Railway Shops of the Grand Trunk Pacific

Buildings to House Car Construction, and Locomotive Repair Equipment Nearing Completion—Layout of Plant, the Floor Space of which is Seventeen Acres.

By L. C. Harkness.

THE mammoth railway shops of the Transcona, about four miles from G. T. P., which are located at Winnipeg, are rapidly nearing completion. The first concrete was poured on July 14, 1909, and since that date, about 500 men including foremen, iron workers, concrete workers, and carpenters have been working on the elaborate details of the plans. The railway has acquired a piece of territory one half mile wide, and two miles long, on which the shops are being erected, and the total floor space of the shops which are already planned will total seventeen acres.

The entire construction is designed to care for the general repair of 1,800 miles of railway. Neither locomotives or cars will be built at Transcona, but the equipment will be such as to make it possible to manufacture certain parts. This will mean that the shops will be a very important industrial centre, and it is for this reason that the buildings are all planned on a large scale and with provision for 100 per cent. extension, if necessary. The structural material also

is of the very best available, and has been erected with the greatest care possible to ensure a long period of permanent service. With the exception of these buildings, namely, the storehouse, oilhouse, and stores platform, all buildings are of steel construction, with self-supporting steel frames, concrete foundations, and concrete walls up to the windows; the super-structural masonry being of brick. The buildings mentioned are altogether of re-inforced concrete and brick construction. The equipment and power used in all the shops will also be the most complete and efficient that can be secured and when the whole is completed one of the greatest machine shops on the Continent will be in operation.

Buildings.

The total number of buildings in the shops is eighteen and the names with dimensions are as follows:

Locomotive, machine and erecting shop, 170 x 612 feet x 47 feet high. Boiler tank shop, 185 x 210 feet x 47 feet high. Stores and scrap shop, 40 x 220 feet, x 47 feet high. Forge shop, 100 x 260

feet, x 47 feet high. Grey iron foundry, 130 x 200 feet, x 47 feet high. Power house, 110 x 150, x 49 feet high. Cleaning room, 48 x 80 feet, x 25 feet high. Locomotive carpenter and pattern shop, 70 x 100 x 42 feet high. Stores, 60 x 200, x 18 feet high. Wheel foundry, 92 x 135 feet. Engine house, 170 feet radius, 1,068 feet circumference. Freight car shop, 200 x 600 feet. Paint shop, 100 x 325 feet. Coach shop, 125 x 250 feet. Planing mill, 100 by 300 feet. Lumber shop, 60 x 115 feet. Dry kiln, 40 x 50 feet.

Departments.

The entire plant is divided into three departments namely, locomotive shops, car shops, and the power house. These are not given distinct locations, but are built according to the convenience of power distribution, and trackage facilities. To this end the general plan of the shops is systematically arranged on either side of the spacious midway which runs north and south across the entire property. The various buildings are served by a series of standard gauge service tracks branching off from the



Fig. 3.—No. 3 of Panoramic View Showing Locomotive and Machine shop.

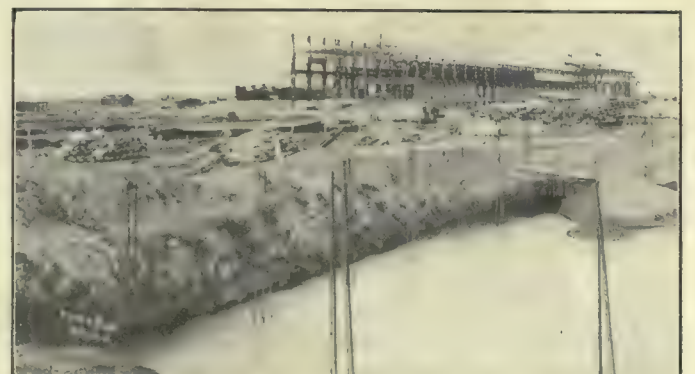
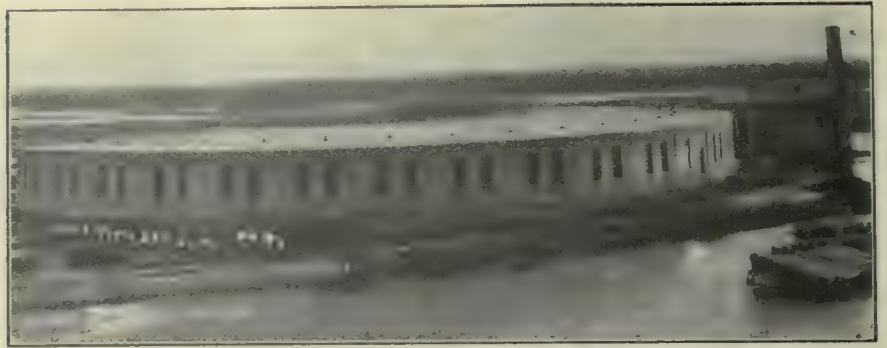

Fig. 4.—Steel Frame of Locomotive Shop.

yard tracks at the south and the communication between the buildings is obtained by narrow gauge tracks, and an overhead travelling crane which runs the full length of the midway.

Illumination.

The interior illumination will be provided by Cooper-Hewett lamps and all the buildings will be heated by direct and indirect radiators installed by Cotter Bros., Winnipeg. High and low pressure steams, water, compressed air, and drinking water will be throughout the various buildings with numerous outlets. Oil will be distributed under pressure from the storage tanks to the furnaces in the boiler shop, while an accumulator provides pressure for operating the various hydraulic machines. The electric travelling cranes through-



The Roundhouse in Connection with G.T.P. Shops.

bedded in bituminous concrete is used in most of the shops.

Locomotive Shop.

The locomotive, machine and erecting shops consist of three bays each 612 ft. long and respectively 70, 60 and 40 ft. wide. The 70 ft. bay is designed for 25 engine pits. Spanning the 70 ft. bay is a 120-ton crane for handling locomotives and under it is a 10-ton crane for general work. Two 10-ton cranes span the 60 ft. bay in which will be installed the heavy machine tools and also the flue department.

The lighter machines will be installed in the 40 ft. bay where the work on bolts, side rods, links, etc., will be accomplished. At the east end is the riveting tower served by a twenty-ton crane. Overhead in the 40 ft. bay is a balcony running the whole length of the bay on which are located the heating equipment, lockers, brass department, etc.

The boiler shop is laid out in four departments, which are equipped respectively with a 20, 30, 10 and 5-ton electric travelling cranes. The 10-ton crane is in a 50 foot bay devoted to heavy machinery which is driven by both individual and group motors. In the forge shop the machinery is all driven by three 40 H.P. motors carried on wall

brackets. A motor driven blower furnishes the necessary blast for the furnaces through underground and overhead piping. The steam to the hammers and exhaust return the oil, and hydraulic piping are carried in concrete ducts through the shop and to the various machines. The spring department is in one end of the forge shop and handles the spring work for both cars and locomotives.

The frog and track shop is designed to handle repairs for all frogs, switches and interlocking plants. It is spanned by a 10-ton crane, and is equipped with saws, light hammers, drills, planes, etc., also two groups of small machines driven from line shafts for the lighter rod and bolt work.

The Foundry.

The Grey Iron Foundry which will supply both the locomotives and car departments, is 130 ft. x 200 ft. with a cleaning room annex 60 ft. x 80 ft. and is equipped with five cranes of various capacities. There is also a 5-ton auxiliary hoist for handling light material, and several small job cranes for handling flasks. The scale room for weighing charges is in this shop, and loaded cars after weighing are taken by a pneumatic elevator to the charging room, where they are handled by pneumatic charging machines. The charging floor is of steel plate with a transfer table and storage tracks. In addition to other ordinary machinery in this building,



G.T.P. Power House Where 4,000 H.P. is Generated and Chimney 200 ft. High.

out the plant are equipped with alternating current motors and are operated directly from the three-phase circuits. A wide wooden floor spiked to sleepers

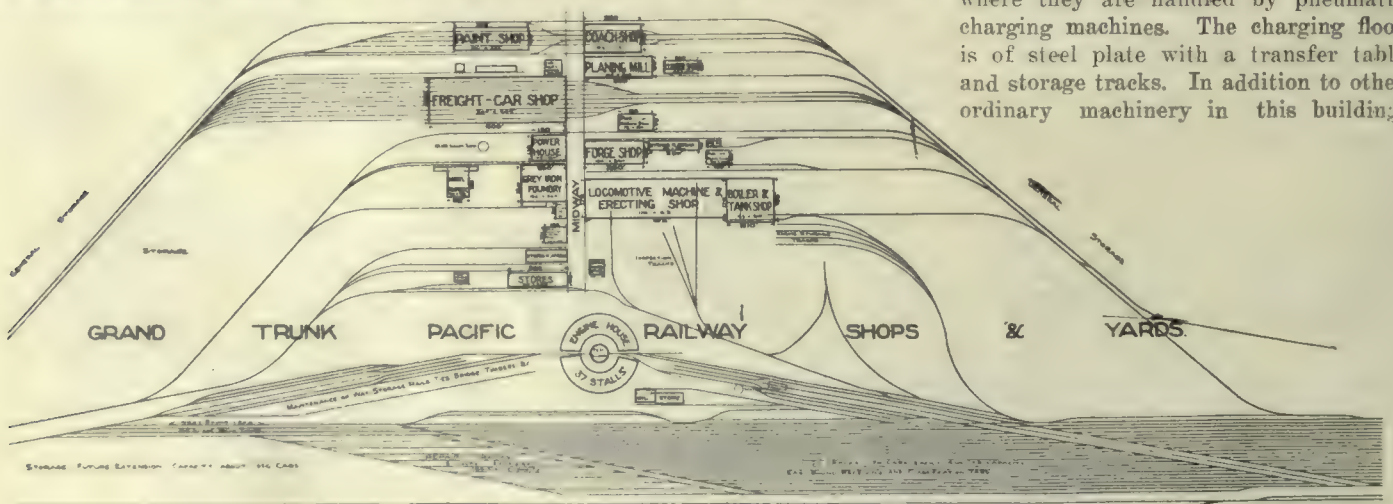

Plan of the G.T.P. Ry Shops and Yards, Transcona.

there will be a brake-shoe, and a gravity molding machine installed on the mold-floor.

On the south side of the building is the brass foundry equipped with brass furnaces. There is an equipment of tumblers, grinders, etc., in the annex to the main building.

Car Department.

In the car department the coach repair shop is the largest building, having accommodation for twelve standard coaches and a 16 foot balcony extends along both sides. The north balcony is devoted to cabinet work and is equipped with light tools such as scroll and band saws, lathes, drills, etc., all being driven from a line shaft. The south balcony is devoted to upholstering, transmitting and finishing and is equipped with a small brass shop, containing lathes, planes, drills, tow buffing machines and a lacquer oven. On the main floor is the wood working machine and nickel department.

The freight car shops are also large and can accommodate 108 freight cars.

material can be run in and unloaded at the machines. One side of the building is devoted to mill work and the machines are to be managed so that the material goes through without doubling back.

The wheel foundry is laid out on the straight line floor principle with four floors of 25 wheels each, giving a capacity of 100 wheels a per day. The wheel and machine shop proper is equipped with a 10-ton crane, wheel boring mills, axle lathes, wheel press, wheel lathes, and tire furnaces for the wheel work, and for car shop machine work there will be arch bar drills, lathes, planes, drills, grinders, etc.

Power House.

The power house is equipped with ten water tube boilers in units of about 400

generators one driven by a simple engine, the other by a motor. There are two exciter units driven by a simple engine, and a 1,500 cu. ft. capacity Corliss engine, driven by air compressor.

The details of the construction were prepared under the supervision of Frank A. Walker, M.B., who is also supervising the entire construction. The general constructors are Hanley, Quinlan and Robertson. The steel construction was in charge of P. T. Farelly, most of the steel being secured from the Manitoba Bridge and Iron Co., Winnipeg. The total cost of the construction and equipment of the shop in the neighborhood of \$3,000,000, and when in operation will employ about 3,000 men. It is expected that the entire plant will be

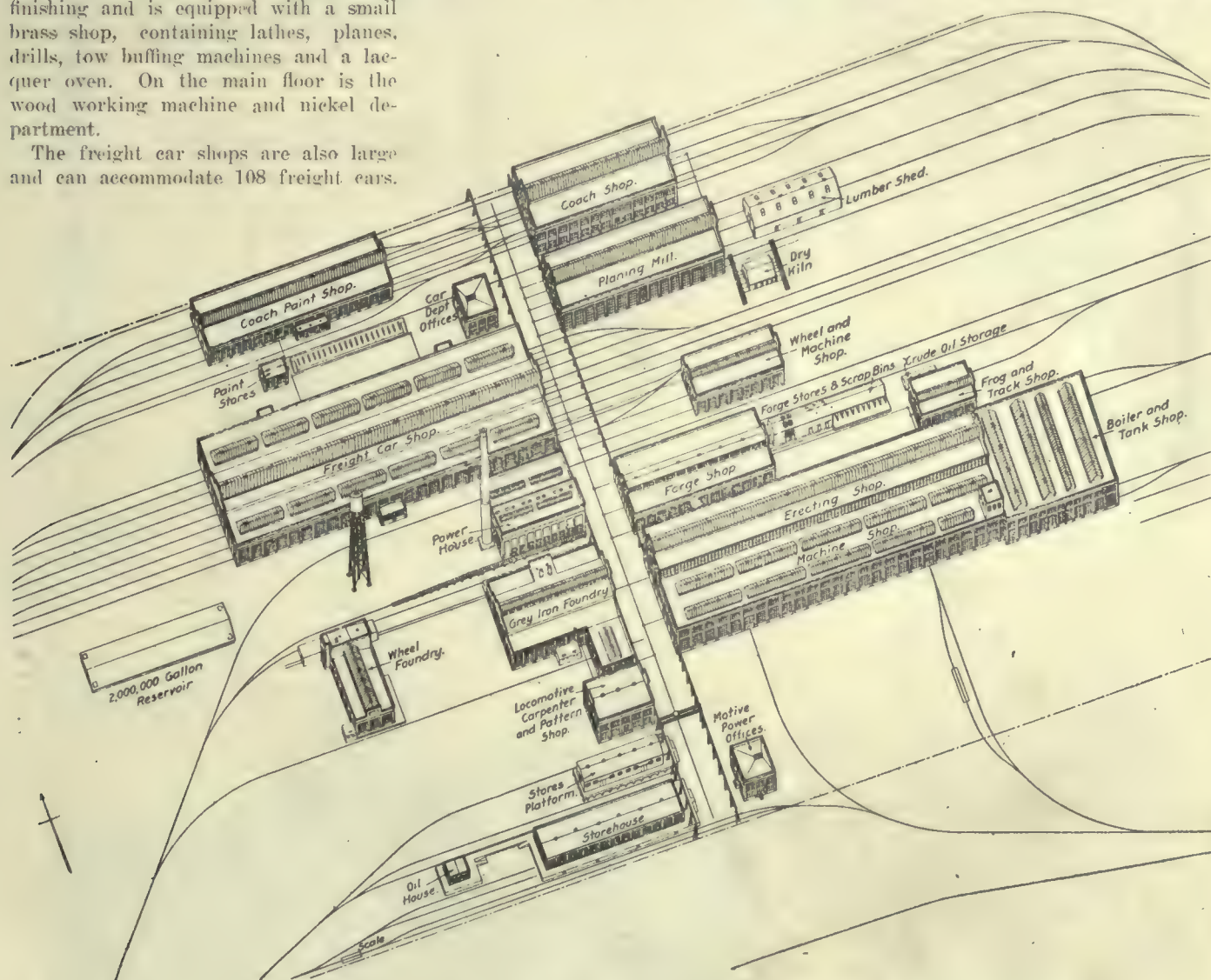

G.T.P. Shops, Transcona, Near Winnipeg.

A 20-ton crane 65 feet long at a height of 30 feet handles the heavy material in this building. The large crane is also equipped with a 5-ton auxiliary. The planing mill is placed so that cars of

h.p. each. There are three 500 k.w. a.e. generators, driven by direct connected cross compound Corliss engines, one 250 k.w., a.e. generator driven by a simple engine, and two 150 k.w., d.e.

ready for operation by May 1, 1911, at any rate the railway construction work and transportation will have progressed to such an extent as to require the use of the shops by that time.

Mechanical Features of St. Andrew's Dam and Locks

First Structure of its Kind in the Western Hemisphere,
Employing Several Interesting Mechanisms in its Operation.

The St. Andrew's dam has been erected at St. Andrew's Rapids on the Red River, Manitoba. The structure retains a head of 21 ft. and 800 ft. in length. A feature of the dam is that it can be put in place in the spring and removed in the fall. The type of dam is known

after the gradual lowering of the head of water. This is done by gradually rolling up the curtains.

Curtains.

The curtains each consist of 50 wooden laths 7 ft. 7 ins. x 3 ins. and a thick-

Copper links connect the laths and are designed, and are machined with great care. The copper is composed of 88 parts copper, 10 parts tin and 2 parts zinc. The tensile strength of the links is 20,000 lbs. per sq. in. The pins connecting the links are phosphor bronze with an ultimate tensile strength of 140,000 lbs.

The curtains have for their base a rolling cast iron shoe of the form of an archimedean spiral, and they are rolled

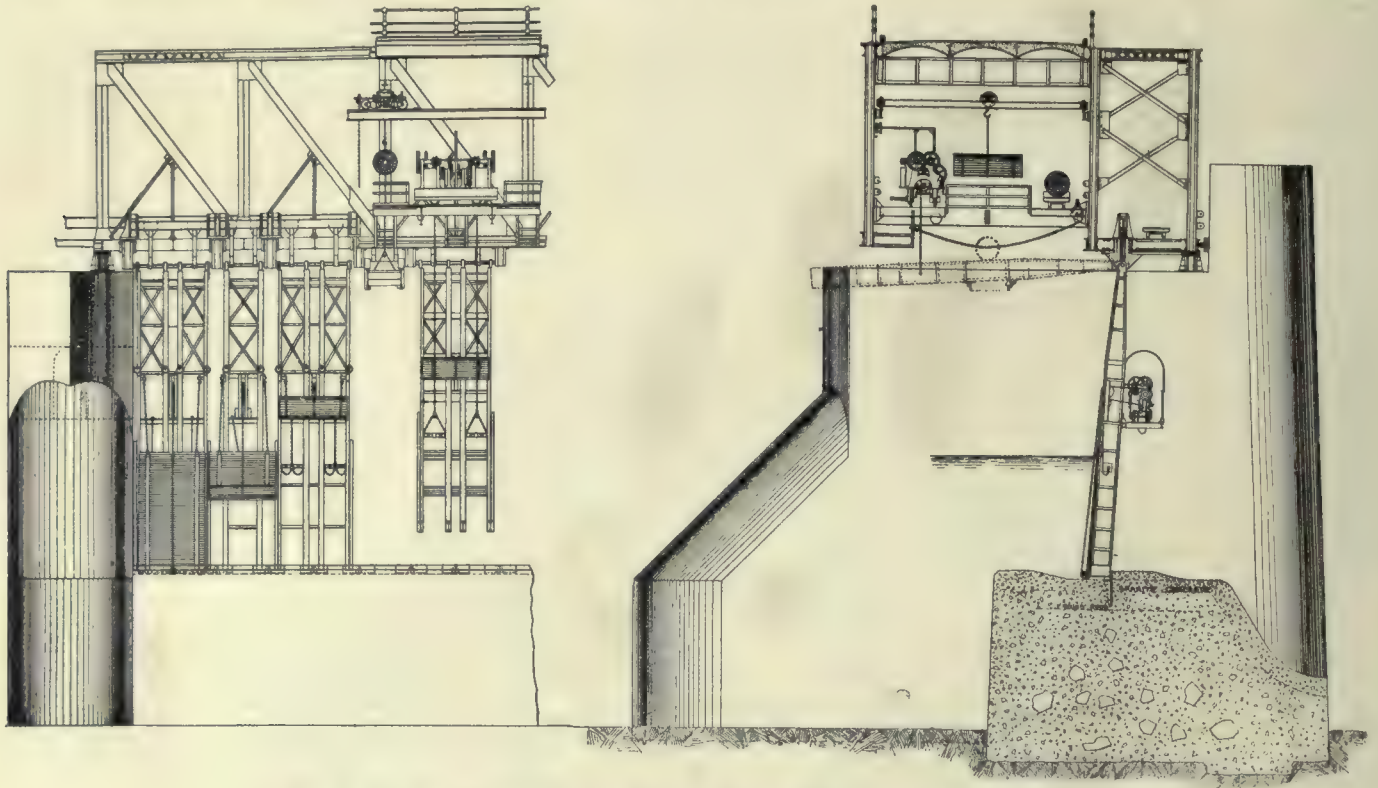

Fig. 1.—St. Andrew's Rapids Movable Dam Showing the Mechanical Features.

as the Camere Curtain Dam and is the first to be constructed in the western hemisphere. There are only two other similar dams in the world, these being operated by the French Government on the Seine River, France.

At the St. Andrew's Rapids the Red River is about 800 ft. across. At this point heavy concrete piers have been placed in the river 133 ft. 8 ins. centres. Running between those piers and embodied with them is a heavy concrete submerged dam, extending 7 feet 6 inches above extreme low water, its top providing a seat for the castings carrying the foot of the curtain frame girders.

The supporting framework of the dam consists of a series of steel truss bridges resting on these piers. Fig. 1 shows the normal position of the dam during the summer months. Each truss span supports 46 curtain frames and 15 sets of curtains. At the end of the season of navigation and before the ice forms, both curtains and frames are removed,

ness of 1 21-32 to 3 5-32 ins. Lath No. 1 is designed to accommodate the casting carrying the links and attachments for the supporting chains.

by means of a travelling windless. The curtains have any lateral travel limited by guides on the supporting frames.

The lock is situated at the west side



Fig. 2.—View of Dam With Curtain Frames Raised, Also Upper End of Lock Chamber.

of the dam. The lock chamber is 215 feet long between hollow quoins 45 feet wide and with walls 34 feet in height above the lower sill. The walls have a total length of 290 feet, including wing walls.

At the upper end the lock is fitted with a pair of gates 28 feet long and 37 feet high from bottom of gate to floor of foot bridge. The lower gates are 28 feet long and 23 feet high from bottom of gate to floor of foot bridge.

The filling and emptying valves are located above and below each set of lock gates and are automatic cylindrical valves, adapted from the Fontaine cylindrical valve used in France. These valves are of special interest inasmuch as the working parts are not subject to pressure due to head and the valve will

be therefore easy to manipulate under the maximum head of 21 feet.

Machinery Equipment.

The control of the frames and curtains by means of travelling electric cranes, operated from the service floor of the bridge is the leading mechanical feature of the structure. There are four steel tracks running the entire length of the dam, on which may be run the cranes, which control the frames, and which may be used to effect necessary repairs in the future.

Four cranes are employed for hoisting the curtain frames. Two are each equipped with a 20 h.p. and a 2 h.p. C. G. E. motor. The two smaller cranes are equipped with 10 h.p. motors but are moved by hand. There are three cranes for handling the curtains, each

equipped with a 2 h.p. motor. There are also six travelling overhead cranes, four 4-ton over the working floor of the dam, one 2-ton in the repair shop and one 2-ton crane in the dynamo room.

Repair Shop.

The building is 90 ft. x 40 ft. and houses the boiler and engine rooms. In the boiler room is one C. G. E. boiler with 735 sq. ft. heating surface and a Champion forge. In the engine room is a Robb-Armstrong engine direct connected to a 40 k.w., 250 volt., direct current generator, one motor generator set, 60 h.p. motor and 40 k.w. generator, 2,080 volts, and switchboard.

In the repair shop is a specially designed saw for cutting laths, rip saw, 12 in. molder, planing a lath complete in one operation, and one wood boring machine.

The Use and Advantages of Steel Balls in Machinery

The Increased Use of Steel Balls in Bearings has Resulted in the Elimination of a Large Amount of Friction and the Consequent Saving of Power.

THE application of steel balls to many different bearings is resulting in a great saving of power. In order that the possible benefits may be obtained the steel balls must be absolutely alike. In their manufacture a variation of one ten thousandth part of an inch is sufficient to reject it. In the manufacture of Hoffman steel balls a Newall measuring machine, Fig. 1, is used in keeping gauges standard. In gauging, the ball and gauge are immersed in a thin oil, such as paraffin, and are allowed to remain there until both are the same temperature.

For light loads such as are met with in cycle construction, steel balls stand well between conical cups and cones of the usual type, but for the loads that have to be carried in the usual run of engineering and automobile work, it is essential that the balls are supported in races having two points of contact with the ball only, which points of contact must be directly in line with the load, that is to say, for journal bearings at right angles to the axis, and for thrusts parallel with the axis. Where both journal and side thrust have to be provided for, separate rows of balls should be provided. All ball races should be accurately ground and polished. Highly polished steel balls are extremely susceptible to rust if exposed to a damp atmosphere. It is, therefore, of great importance to see that they are stored in a dry place, are handled as little as possible in as-

sembling, and are thoroughly well greased as soon as they are put into the bearing.

Fig. 2 shows a very good application of ball journals and double thrust washers to a typical gear box. The short driving shaft has, first of all, a journal bearing with a parallel hole, slipped on to it, then the double thrust bearing, which has previously been properly adjusted and locked upon its sleeve, then a small journal bearing, and the outer sleeve which is used to clamp the thrust bearing in position.

A nut screwed on the shaft at the end then firmly clamps and locks all these bearings in position. The propeller shaft is mounted in a very similar way. It, however, has a small journal bearing at one end of it, which should be a tight press fit on the shaft, and locked in position by means of a screw in the end of the shaft, the head of which projects over it. This bearing should be a sliding fit in the enlarged end of the short driving shaft.

The two shafts are then dropped into the bottom half of the gear box, the top

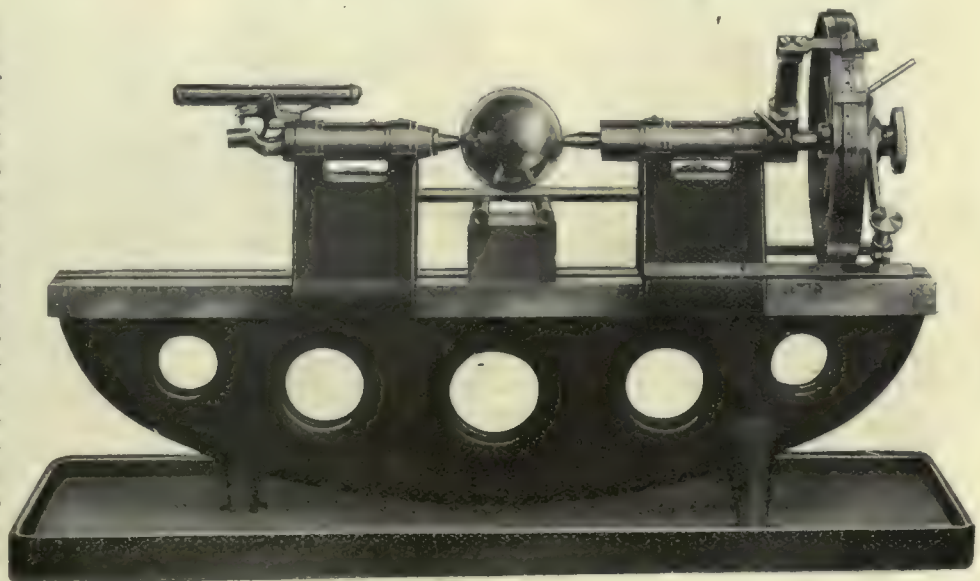

Fig. 1.—Newall Measuring Machine.

half put on, and the end caps, which carry leather dust washers, serewed home, clamping the centre races of the double thrust washer in position against the gear case. It is important to see that the faces of the gear case against which the centre races of the double

touring cars, however, it is found sufficient if two hardened steel plugs are inserted at each end of the gear case, which abut against hardened steel plugs in the end of the shaft. In both cases the outer ball races should be a sliding fit in the housing.

only prevent dirt and moisture getting into the bearings, but also help to retain the grease in the bearing.

In cases such as a worm gear driving a single acting pump, or where the load is constantly being thrown on and off by means of clutches, or varies in amount, if only a single thrust bearing be used, the spring in the framework and gear when the load is released is generally enough to allow the balls to get out of contact with their races, and consequently permits them and their races to drop slightly out of their true position of concentricity and to be violently forced home when the load comes on again. This is very detrimental to single thrust bearings, and they cannot be expected to withstand such shocks and jars. By the use of a double ball thrust bearing the shaft is held firmly in both directions, and all shocks and jars from the above cause are prevented, not only in the ball bearing itself, but also in the worm and other gear in connection therewith. The life of the latter is therefore very much increased, and a smooth running gear is the result. Where the end thrust of a long screw, such as is used in planing machines, or of a worm, has to be taken in both directions, two single thrust bearings, one at each end, should not be used, as the variation in the length of shaft, due to heating or other causes, often puts an enormous overload on the bearings, and when the shaft is again at its normal length, admits of a certain amount of slack, allowing shocks and jars, which, for the reasons stated are very detrimental.

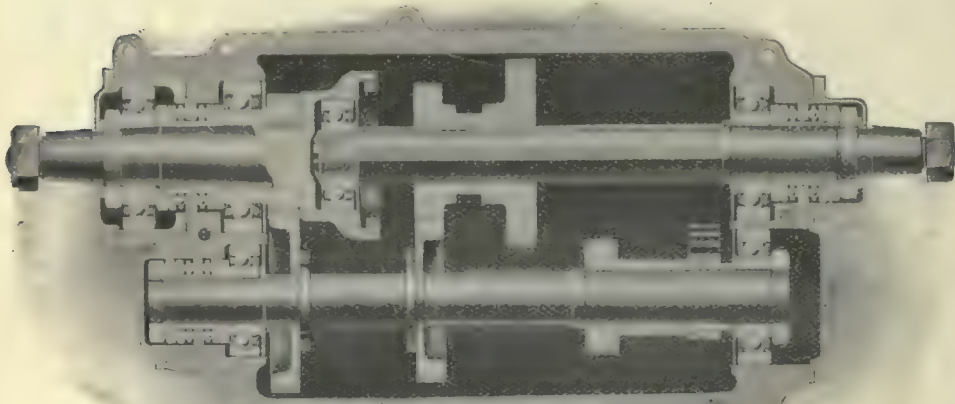

Fig. 2.—Application to Gear Box of a Motor Car.

thrust bearings fit are perfectly true, and at right angles to the axis of the shaft. The countershaft is also shown mounted with a double thrust washer. This is an absolute necessity in the case of heavy cars, such as motor 'busses, lorries, etc., and in all commercial cars where the duty is high. For lighter

Thrust Bearings.

Fig. 3 shows the application of steel balls to hanger for line shafting. Fig. 4 shows a single ball thrust bearing. To prevent access of grit, dirt, and moisture to the bearing, it has been found the most suitable method is to employ two leather dust washers side by side, one turned inwards and the other outwards, the loose edges of which

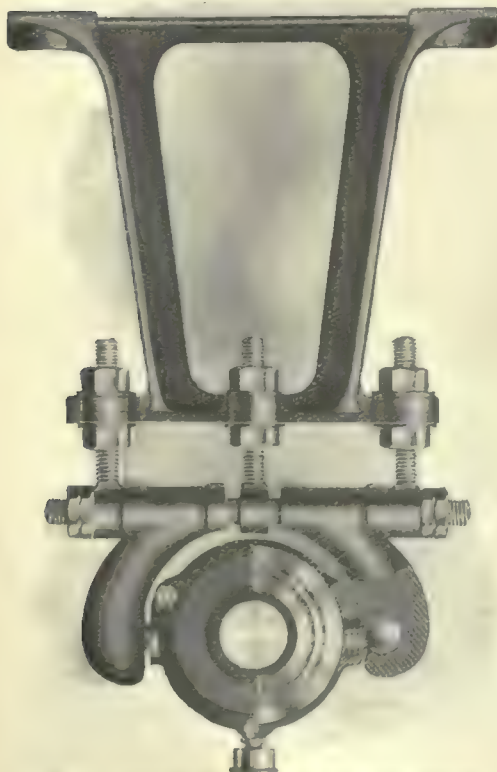

Fig. 3.—Application to Hanger for Line Shafting.

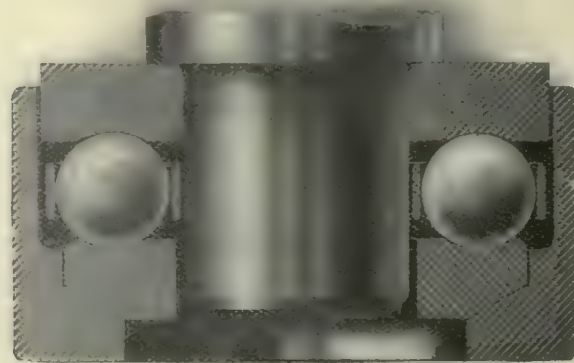

Fig. 4.—Hoffman Single Ball Thrust Bearing.

rest upon the shaft. A piece of felt butting against the shaft is not so good, as it does not give to the shaft as these leather washers do. These washers not

Ball bearings have been successfully applied to electrical machinery, machine tools, pivots of cranes, turntables, fans, etc. They are used for carrying loads

of from 1 to 500,000 lbs., and at speeds from 1 revolution to 30,000 revolutions per minute.

is about half as large again as the largest diameter of the vertical portion of the knuckle. The end of the bar is first

in the dies under the drop hammer. The stock projects from C, and a $\frac{3}{4}$ inch flash space all around the die allows for the usual expansion. When roughed down still further, forming a considerable flash, it is hot-trimmed under a

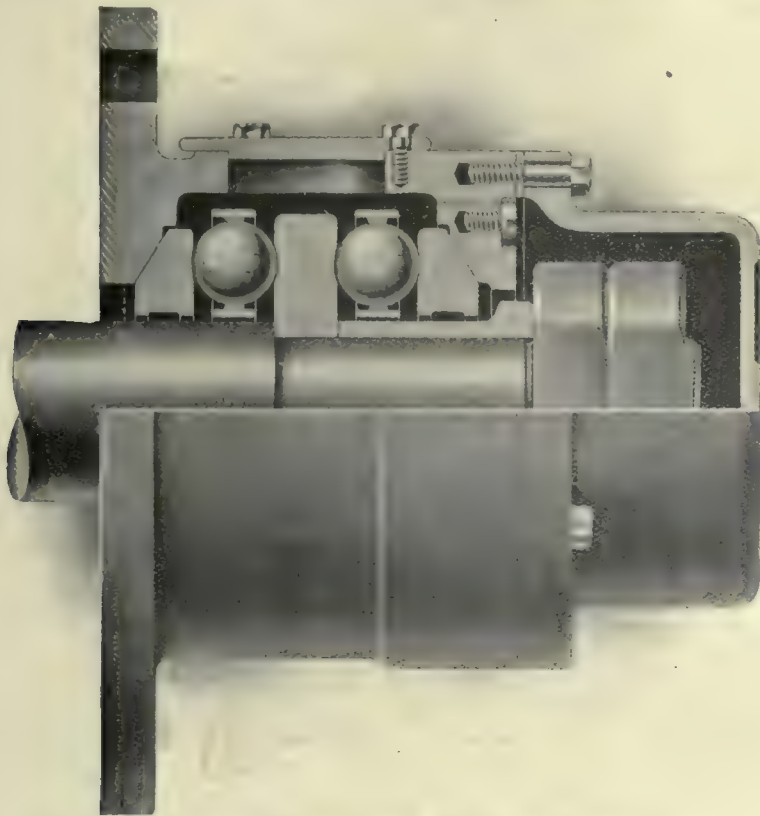
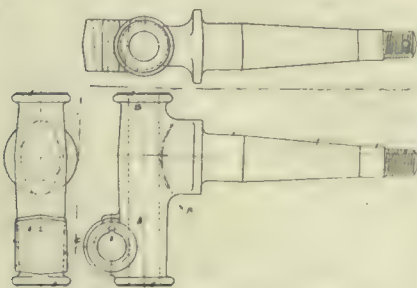

Fig. 5.—Hoffman Double Ball Thrust Bearing.

The illustrations show applications of Hoffman Steel Balls, John Millen & Son, 321 St. James St., Montreal, being the Canadian agents.

DROP FORGINGS.

The illustration shows two interesting pieces of drop forging work, as done by the Canada Cycle and Motor Co., West Toronto, in their automobile factory.



Automobile Steering Knuckle.

Nothing of an intricate nature, such as the front automobile axles, which are drop-forgings, is attempted, but merely the smaller details, examples of which are given herewith.

Of the two pieces, the steering knuckle is the more interesting from its irregular shape. The stock bar is 2 1/4 inches round, heat-treated carbon steel, which

swaged under one side of the drop hammer on a plain anvil, to conform approximately to the axle taper and size. Succeeding this operation, the bar, thus tapered and attenuated, is bent approximately right angles, in a roughly form-

couple of cast iron dies, cast to shape. The forging is then completed under the hammer in the dies. All this is done at one heat.

The lamp bracket form a somewhat different piece of work to produce. The stock bar, which is 1 1/2 x 1, is first split down the necessary distance to give the two prongs, by first cutting, and then bending the two arms away from each other and perpendicularly to the larger

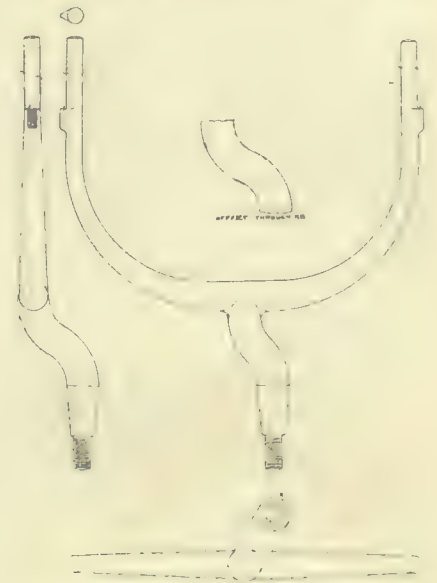

Automobile Lamp Bracket.

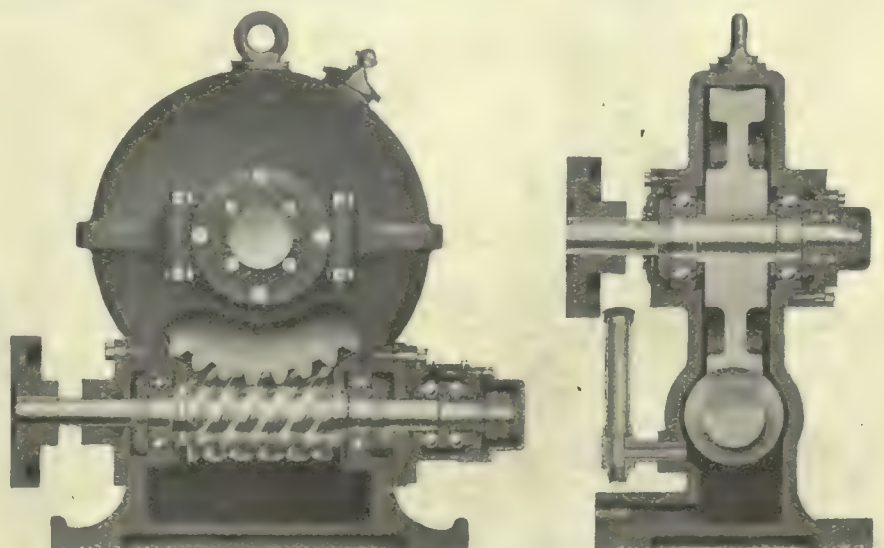

Fig. 6.—Application of Hoffman Double Ball Bearings to Worm Gear.

ed die at the side of the main die block. This same die, which strikes from direction A, forces the metal up to form the top projection B, so that the stock is roughly in shape, and can next be placed

face of the flat piece. The manner in which the cutting dies operate, leaves the projecting arms in nearly the required shape. The piece, then put under the dies, is formed as shown.

Speeds and Feeds for Gear Cutting; and Grinding Data *

Useful Data on Rates of Feeds and Speeds for Cutting Steel and Cast Iron Gears—
Desirable Limits for Grinding, Shrinking, Forcing and Running Fits.

By Luther D. Burlingame. **

The data sheet, Fig. 1, gives data for commercial work in cutting 16-pitch cast-iron gears with ordinary carbon-steel cutters, high-speed steel cutters, and with and without an air blast. The gears cut when these records were made are all gears that passed inspection and were put into use. The last gear of each group cut before sharpening the cutter was preserved, also samples of chips from each cut.

It will be noted that the use of the air blast adds materially to the rate of production, as will be seen by comparing the feed in inches per minute of Nos. 1 and 3, where a gain of nearly 70 per cent. is made when using the air blast with carbon cutters, and by comparing Nos. 2 and 4, where a gain of 40 per cent. is made when using the air blast with high-speed cutters.

The high-speed steel cutters with the air blast give an increase of production of almost 4 to 1 over the carbon cutters without the air blast. In cutting cast-

iron gears of coarser pitches the gain is in about the same proportion. Even under the fastest cuts the gear teeth show surprisingly little tendency to break out at the back, although cut without being supported.

Fig. 2 shows the matter of applying the air blast. A Sturtevant blower was used, the air being supplied from a tube $1\frac{1}{4}$ inches diameter at a pressure of about $1\frac{1}{2}$ ounces per square inch, this being sufficient to cool the cutter and keep the chips cleared away.

Cutting Steel Gears.

The following records are of commercial work done in the gear department of the Brown & Sharpe Mfg. Co. In the first example three finishing cutters were used in a gang, finishing three teeth at once. In the second, better results were obtained by using a stocking and finishing cutter together than by using two finishing cutters. The data for these examples are as follows:

(a) Gears of steel castings, 70,000 pounds tensile strength, 3 pitch, 5 inches face, 67 teeth; cutter, 6 inches diameter, $1\frac{3}{4}$ inches hole, 52 revolutions per minute, 81 feet surface speed per minute, 2 9-16 inches feed per minute; feed,

0.049 inch per revolution of cutters. The three cutters cut three gears in 67 minutes each, without sharpening the cutters which were than in good condition and could have cut several gears more.

(b) Gears of steel castings, very hard, 3 pitch, 5 inches face, 51 teeth; the cutters, 6 inches diameter, $1\frac{3}{4}$ inches hole, 28.61 revolutions per minute, 45 feet surface speed per minute, 1 3-16 inches feed per minute; feed, 0.042 per revolution of cutters; cutting time, 5 $\frac{1}{2}$ hours. Oil was used as a lubricant.

The roughing cutter used in the second example was a new design of stepped stocking cutter shown in Fig. 3.

Roughing Out Gear Teeth.

The following record was made with the new design of stocking cutter in roughing out gear teeth:

Gear blanks of machinery steel, 65,000 pounds tensile strength, $4\frac{1}{2}$ inches diameter, 6 inches face; cutter, 3-pitch stocking, $5\frac{1}{4}$ inches diameter, $1\frac{1}{2}$ inches hole, 90 revolutions per minute, 124 feet cutting speed per minute, 7 inches feed per minute; feed, 0.078 inch per revolution of cutter. Cut 15 teeth, 0.749 inch deep; total number of inches cut, 90.

* Presented at joint meeting of British Institution and American Society of Mechanical Engineers.

** Chief draftsman, Brown & Sharpe Manufacturing Co.

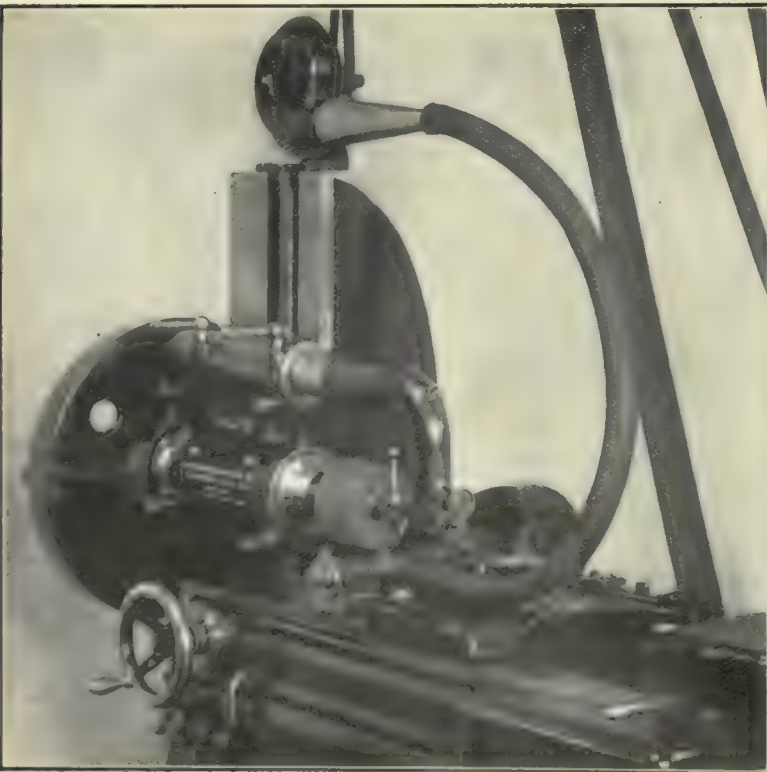

Fig. 2.—No. 3 Brown & Sharpe Automatic Gear Cutting Machine with Blower Attachment.

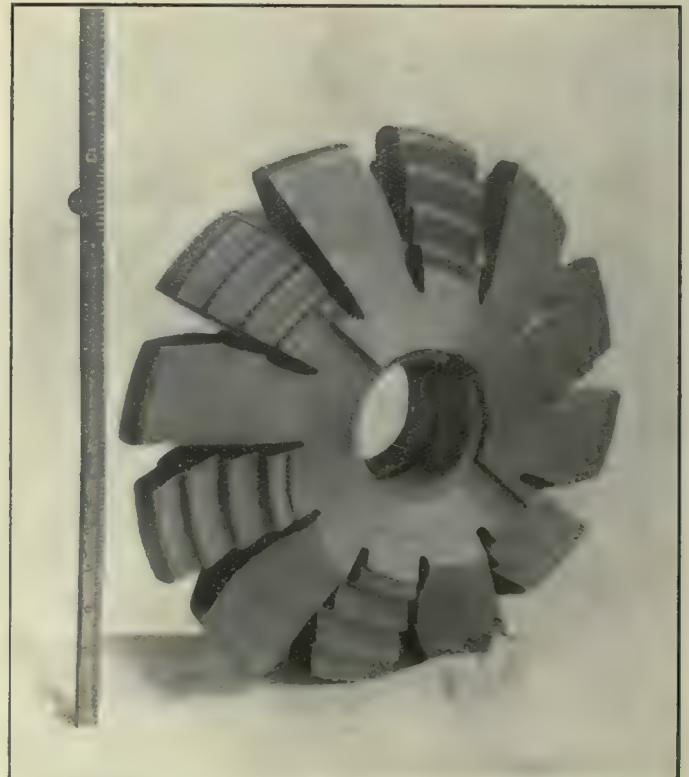

Fig. 3.—12-in. Diam. Stepped Stocking Cutter.

To Increase Output and Decrease Production Cost

Possible Economies where Large Numbers of Duplicate Parts are to be Machined. Some Examples of Work that is being done on Automatic Machinery.

Canadian industries are growing to such an extent that they find they have to turn out a great amount of duplicate work. In a number of industries automatic and semi-automatic machines have been installed, these greatly increasing the output, producing the small duplicate parts at a low cost. Among the machines found in Canadian industries are the Potter & Johnson, Cleveland Automatic, National Acme, Jones & Lamson, Brown & Sharpe and Fellows' gear shapers, etc. These are used in the manufacture of small screws, the many small parts used in the construction of an automobile, agricultural implements, etc., cream separators and a number of other lines manufactured in Canada.

A few months ago the manufacture of the Magnet Cream Separator, was described in Canadian Machinery. This Separator is made by the Petrie Mfg. Co., Hamilton, Ont., and a number of automatic machines are used in turning out the parts such as gears, bar

work, etc., these cutting the cost of machine work.

Among the machines used by the Petrie Mfg. Co. are one Fellows' gear shaper and two of Brown & Sharpe's five Cleveland automatics, three Potter & Johnson's turret lathes, six Jones & Lamson turret lathes.

In the illustration No. 1 are two examples of bar work machines on the Cleveland automatics. There are twenty shapes, the time required for each depending on the amount of machine work. The time required to set up the machine for one of these shapes is three-quarters of an hour.

No. 2 shows a steel forging which is made on a Potter & Johnson automatic. Nine operations are performed on this forging with two settings. One man looks after the three Potter & Johnson machines.

Machining Gears.

The other two of these machines work on gears, the two styles Nos. 3 and 4 being made. On each style there are

seven operations performed at one setting of the tools. The following are the operations: bored and reamed, faced on both sides of rim, faced on the periphery, faced on both sides of hub. Forty gears are turned out per day, the tools being ground once in three weeks. The time required to set up the machines for gear blanks is two hours.

The gears are cut on the Fellows' gear shapers and on the two Brown & Sharpe's. All the work is very accurate as the gears of the separator run at 7,500 revolutions per minute.

Many Shapes Automatically Machined.

No. 5 is an automobile main driving pinion machined in two operations on a Fay automatic. One man can attend two lathes and turn out 60 pieces per day. The work is held in the lathe centres. In the first operation the back tool roughs back end of teeth, the carriage turns diameters shown between dimension lines A, and finish turns back end of teeth. In the second operation the back tool turns face of teeth, the carriage turns diameters shown between dimension lines B, and turns front end of teeth.

No. 6 shows a 3/4 inch valve machined on a Prentice automatic. The taper

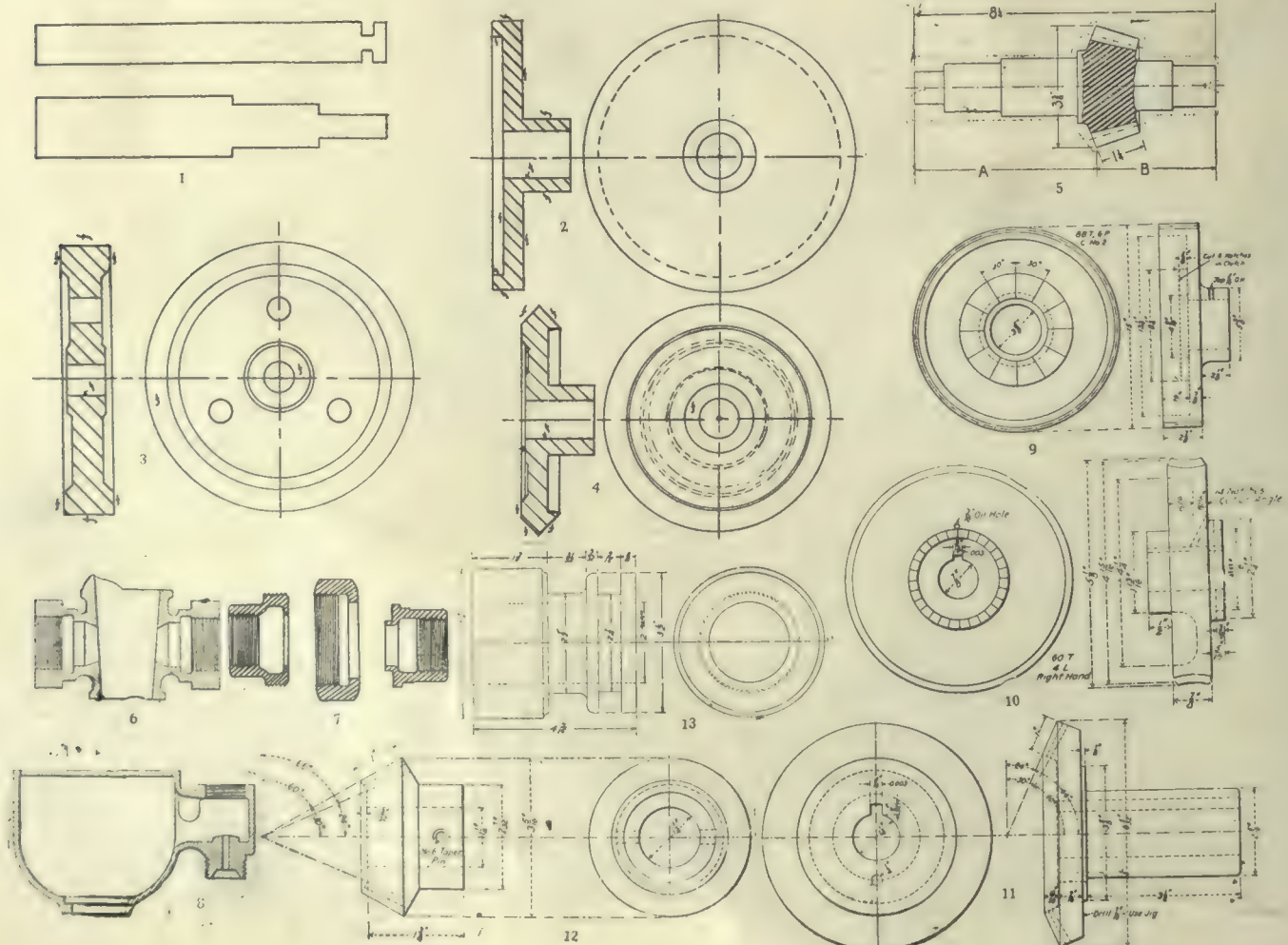

hole was rough and finish bored, 240 pieces per hour. The two pipe ends were bored, faced and tapped simultaneously in a double head machine, 280 pieces per hour.

No. 7 and 8 are also pieces machined on Prentice automatics. No. 7 is a $\frac{1}{2}$ inch union swivel, nut and screw of malleable iron; 150 ends or 50 complete unions, without the threads are machined per hour.

No. 8 is a carburetor bowl, $\frac{1}{2}$ inch size made of bronze and is finished in two settings in a six spindle double-head machine. At first setting large end of bowl is bored, faced and seated; small end is bored and faced. At second setting the regulator end is turned, faced, drilled and threaded outside; bored, faced and tapped inside. The production is 100 complete pieces (all four ends per hour).

The clutch gear, No. 9, is machined on a Davis automatic. The hole is bored and reamed, and the clutch is turned on the inside as well as the outside, the time required per piece being from 45 to 50 minutes.

A $5\frac{1}{2}$ inch worm wheel is shown in No. 10 as also are Nos. 11 and 12. No. 10 is finished in one setting. The wheels are machined in lots of 200 and require an average of 20 to 25 minutes each.

No. 12 is a cast iron bevel gear, the time required in large lots being 25 minutes. No. 13 is a bevel pinion and requires about 15 minutes per piece.

The steel spool for an automobile clutch, Fig. 13, was machined on a Gridley automatic turret. It is chrome-nickel steel and was finished in 28 minutes.

Advantages.

The chief advantage of the automatic or semi-automatic is the increased production at low working cost. In the case of automatic machinery, one operator can look after as many as twelve machines depending altogether on the nature of the work.

In some cases an automatic can be used for two or three months during the year and save sufficient to more than offset its rest from service during the other months. This is the case at the Canada Cycle & Motor Co. where a large number of automatics are in use. A National-Aeme is used for some special work which keeps it in service about half the working year. Its use for this work has been found to pay overhead charges and yield a large profit.

Of course there must be a certain amount of duplicate work to make the automatic pay for itself. Otherwise a great deal of time would be spent in

changing tools and cams, making it much cheaper to produce the work in some other manner or purchase them.

In connection with this article on automatics and semi-automatics, it is

interesting to note that the National-Aeme Mfg. Co. have established a branch in Montreal for the manufacture of their automatic screw machines, cams, tools, etc.

English Practice in Machining Crank Shaft Webs

Manner in which English Methods Differ from those in this Country ;
Machining Crank Webs, showing Operations and Special Appliances

By Horace Howard.

The methods and tools described in this article are the best in use on the north-east coast of England, and are not taken from only one shop, but represent practice in some half a dozen shops, and are a combination of special methods therein used.

The webs for triple crank shafts come from the rolling mills in rough oblong slabs of an average size of 4 x 2 x 8 inches. They are first faced on the planer, where the special tool shown in Fig. 1, does the work. 22 are the tool-holders pivoted at 33. A spiral spring behind the holder keeps them in position. With a double tool like this it is essential that the planer run at the same speed each way. This proves economical both in saving time, and lessening the wear and tear on the machine from the absence of the quick return motion.

After planing the web is scribed as shown in Fig. 2 from steel templates

kept for that purpose, and it is then sent to the band saw to be sawn around the outer edge.

The sawing operation is very interesting, and is shown by Fig. 3, which is a rough sketch of a band saw operating on a web. C is a 1 inch thick plate covering the right half of the table and projecting beyond it, on which are 1 inch steel balls B, in rough steel rings E, made from pipe, to prevent their escape.

On placing ready for sawing, a small wooden wedge A, is tapped in taking the strain off of the steel ball at that corner. The self-acting gear will feed the web into the saw. As the cut must be circular, only short straight cuts can be taken after which the web must be reset. Two to three inches straight cuts can be taken. The plate C is placed on the table to prevent the balls from falling into the slots. It should be of the same length as the table and about half

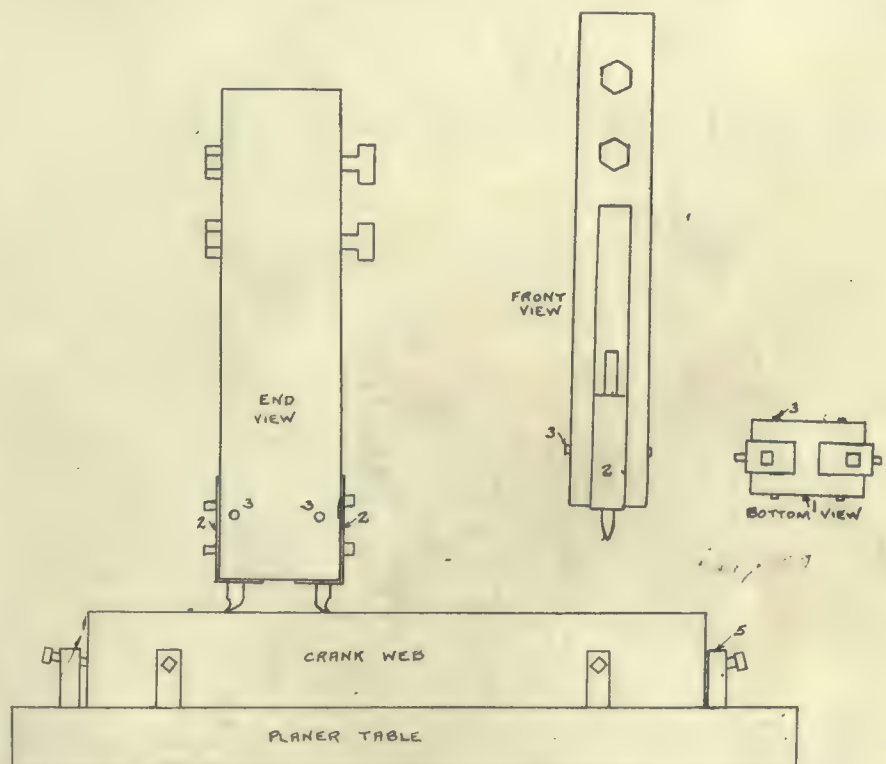

Fig. 1.—Planer Operation on Crank Web.

as wide again, and held down by two countersunk bolts D placed in the first slot as shown.

The two holes FF, Fig. 2 are made in the drill-press for aligning the webs when machining pairs later on.

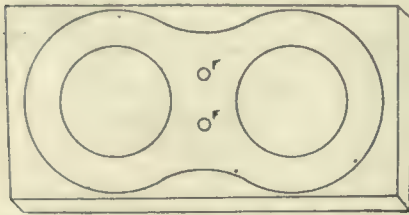

Fig. 2.—Web Scribed Ready for the Band Saw.

Fig. 4 shows the boring or ripping tool used to remove the web centres. G is the boring machine spindle; I, the tool block in which are two oblong holes to hold tools KK, and packing pieces JJ, which are for placing tools at various diameters. In setting the tools K, great care should be taken to set perpendicularly, and to give them the drag shown at L. If the tools were placed in tool block without this drag, they will always have a tendency to dig into the material, owing to the length of tool standing out, but, with drag, the tendency to dig is entirely obviated. It will be noticed that one is a round nose, and the other square, the round nose removing the centre, and the square nose the corners of the cut. Half the cut is made from each side, the web being turned over for the latter part of the operation.

This method is a double labor saver

as it not only cuts the hole for shaft in crank web more expeditiously than by drilling, and then boring it in the usual way, but it saves forging, as these round

placed on the slotter table in pairs, pins F aligning each pair. The oblong false table R is placed on slotter, which is marked by a tool mark to ascertain if it is central, and then bolted down by bolts T, of which there are four. This false

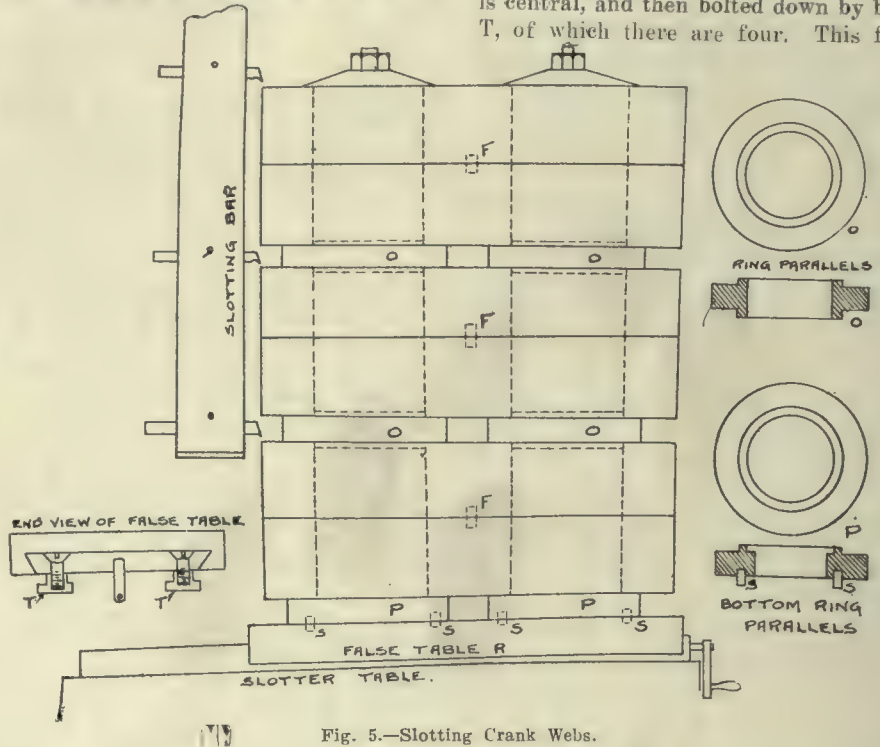

Fig. 5.—Slotting Crank Webs.

pieces as ripped out, are taken to the lathe to be bored and threaded, and then milled hexagon for piston rod nuts, or taken to the saw to be cut into three or four washers, thereby saving labor and material.

The next operation is slotting, shown in Fig. 5. The full set of six webs are

table is drilled to receive pins S, in ring parallels, at the top of which is a spigot the same size in diameter as the web bore. The first pair of webs are placed in parallels, then the ring parallels placed between these and the second pair of webs, and so on with the third pair the whole being bolted to the false table by two bolts as shown. By using

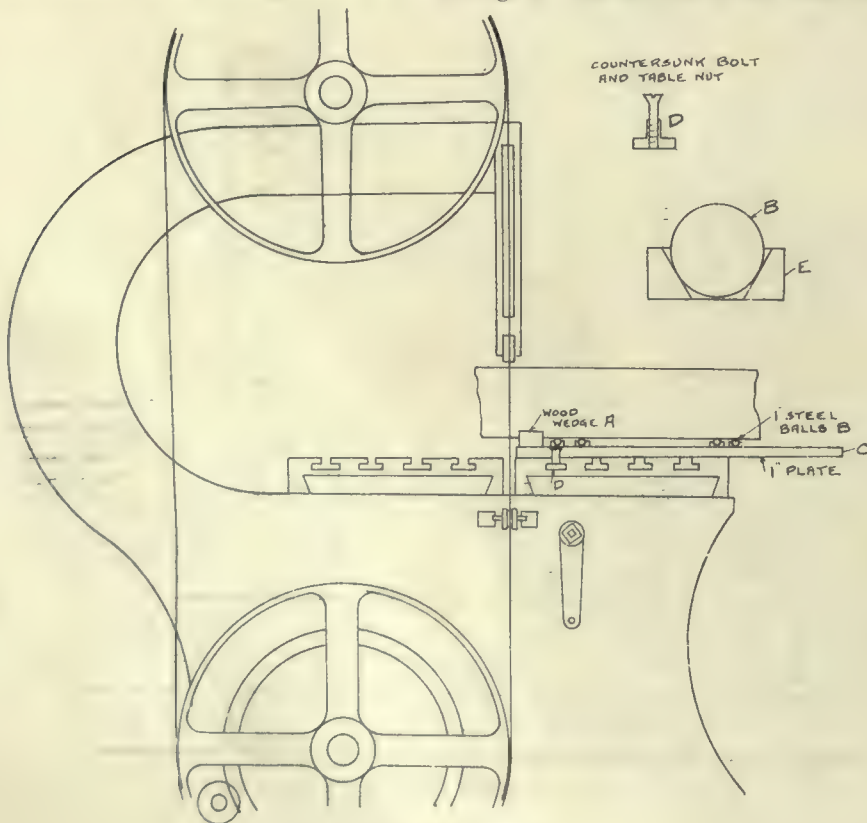

Fig. 3.—Band Saw Operation.

COUNTERSUNK BOLT AND TABLE NUT

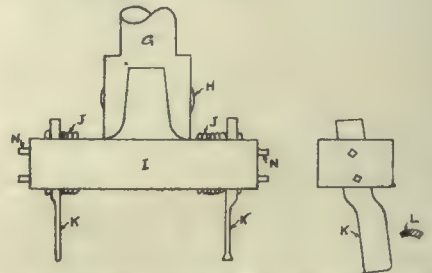

Fig. 4.—Boring or Ripping Tool for Crank Webs.

these parallels with a spigot the size of bore in web, the webs require no setting but merely placing in position. After slotting the first end, it is only necessary to crank the table over for the other end. When both ends are slotted, the whole is moved over and set for the concave radius, in machining which the false table proves of value.

After slotting the webs are removed in pairs to a double horizontal borer to be finished to gauge size, an operation that requires no comment.

MACHINE SHOP METHODS ^A_D DEVICES

Unique Ways of Doing Things in the Machine Shop. Readers' Opinions Concerning Shop Practice. Data for Machinists. Contributions paid for.

CENTRING DEVICE.

By George Ringer.

The accompanying illustration shows a simple centring device that can be used on a lathe for drilling holes in a shaft or jig post.

The device has a V-shaped groove at an angle of 90 degrees. The length is immaterial and can be made to suit the work. A length of ten or twelve inches would be a convenience. The shank is

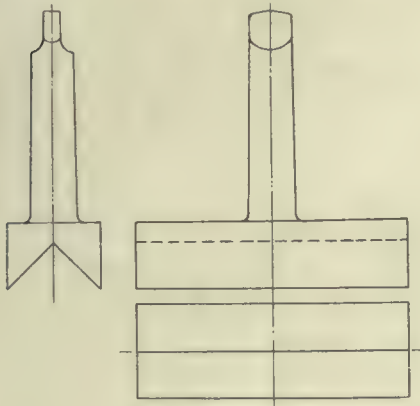

Centring Device.

tapered to fit the tail stock. The jig must be made with utmost care so that the bottom of the V will centre on the head of the lathe.

To centre the shaft, place it in the V-slot, run the tail stock up to the face plate. The shaft will then be centred on the plate and can be clamped in place. For a short shaft the device must be shorter than the shaft to allow the shaft to be clamped to the face plate while the device holds it in position.

PRACTICAL METHOD OF OBTAINING PITCH OF PROPELLER.

By R. Ewart Cleaton.

There are numerous formulae for obtaining the pitch of a propeller which can be used when the various factors forming them are known quantities, but it is often necessary to have the information before the vessel has undergone her trials, and the following method has been found to be quick, and sufficiently accurate for practical purposes. The apparatus required is in no way complicated, is inexpensive to make, whilst the necessary calculations are extremely simple.

Referring to the sketch, the boss A from which the shaft B projects, is bolted to a wall or supporting column, in any convenient manner, and upon this

the propeller is mounted; having a slight taper it will accommodate any size of propeller within certain limits, although the fit must be fairly good to prevent slipping.

The propeller being in place, the quadrant C and the arm D are slid on to the shaft B, and held in position by the set-screws, as shown.

The quadrant forms part (approximately one-third) of a circle which is divided into 100 parts.

The arm D is also divided into equal distances along its length and has attached to it, a sliding socket E, in which, in turn, moves a hardwood batten F, provided with a brass pointer. On the latter there is a movable stop G.

The method of procedure is as follows:

The propeller having been set in such a way that the center lines of the quadrant C, and one blade approximately coincide, the quadrant is then bolted at a distance from the forward edge of the blade, about equal to two-thirds the length of the pointer F, and the arm D is brought hard up against it.

The arm D is then set at such an angle that the pointer touches the blade one inch from the extremity of the after edge and the edge of the arm should then be exactly opposite one of the divisions on the quadrant; should it be between two of the divisions, the quadrant is moved around until a division coincides. The

quadrant is then taken, in order to ascertain how many divisions, or 1-100ths of a turn have been passed through.

It will now be seen, that owing to the advance in the blade the pointer has been pushed backwards, and the stop G no longer rests against the socket E.

The distance moved by G will then be the same fraction of the pitch, as the number of graduations passed through on the quadrant are of 100.

Hence $d : P :: g : 100$ where d=Distance between E and G in feet or parts of a foot.

P=Pitch of propeller in feet.

g=No. of graduation on quadrant passed through.

$d \times 100$

$\therefore P = \frac{d \times 100}{g}$

g

These operations are repeated at different heights of the blade, by moving the socket up or down on D, an equal distance each time, and the pitch is finally obtained by taking the average of the resultant readings. The other blades are pitched in the same manner, the propeller being swung round until the next blade is in position.

A simple method of finding the area of a blade, is to lay a sheet of brown paper over it, and by tapping round the edges with a hammer, cut out a template the exact size and shape. The area is then

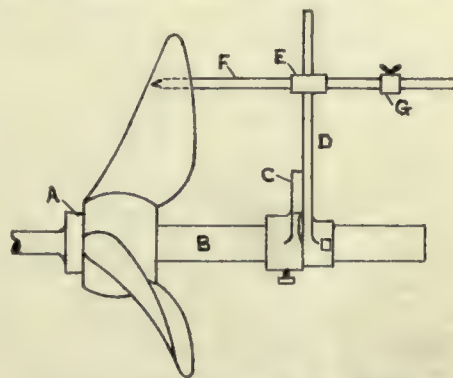

Practical Method of Obtaining Pitch of Propeller.

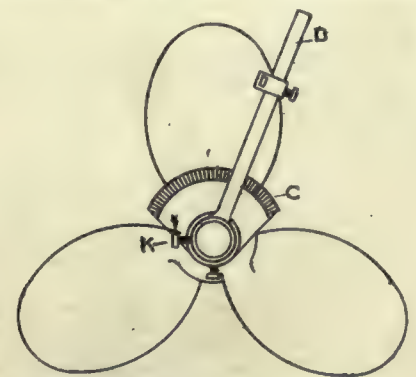

stop G is next brought up and clamped against the socket E, and the position of the arm on the quadrant is then noted; this completes the first operation. The arm is next loosened on the shaft by unscrewing the setscrew K, and swung round to the other edge of the blade, until the pointer is at a distance from the latter approximately equal to that in the first operation, and the edge of D coincides with one of the divisions on the quad-

rant found by dividing the template into an equal number of parts, by the use of an unequal number of ordinates, and applying Simpson's Rule.

$$a = \frac{y}{3} (E \times 48 \times 2m)$$

Where a=Area in square inches.

y=Distance between ordinates.

E=Sum of the extreme ordinates.

S=Sum of the even ordinates.

=Sum of the odd ordinates.

*Late of John I. Thornycroft & Co., Southampton, Eng.

RULE FOR LATHE GEAR CHANGES.

By W. Oelschlager.

In calculating the change gears of a screw cutting lathe, the rule to be given, is intended to teach the beginner how to use the gears as supplied with a lathe, and for general use where tables

4 threads on lead screw $\times 5 = 20$ tooth gear.

10 threads to be cut $\times 5 = 50$ tooth gear.

The 20 tooth gear is placed on the stud, and the 50 tooth gear on the lead screw, as per sketch No. 1.

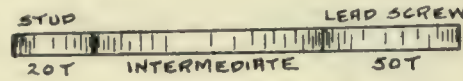
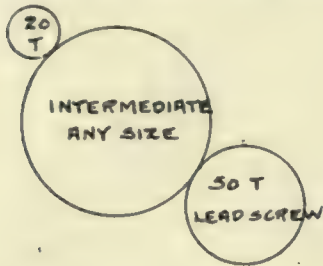

No. 1.

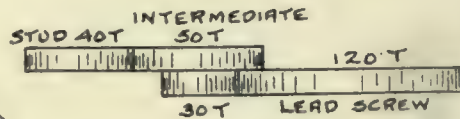
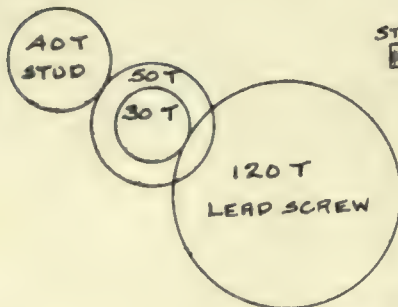

No. 2.

Lathe Gear Changes.

either never existed, or have been lost. It is the simplest and easiest rule in print, to remember.

Consider first simple gearing, proceeding as follows:—Multiply both the number of threads per inch in the lead screw and the thread to be cut, respectively by the ratio of the gears belonging to the lathe. The product of the first is the number of the gear to be placed on the stud, and the product of the latter, that to be placed on the lead screw. The intermediate gear may be anything, as it merely acts as a distance piece.

Now consider a lathe with a coarse 2 pitch lathe screw, and it is desired to cut the same number of threads as in the former example, viz.: 10 per inch. It is unlikely that there will be a large enough gear. Proceed as before, by multiplying the pitches of the lead screw and article to be threaded, respectively by the lathe gear ratio.

2 threads in lead screw $\times 20 = 40$ tooth gear.

10 thread to be cut $\times 20 = 200$ tooth gear.

If no 200 tooth gear exists, proceed as follows: For the first driven, take

any gear for the second driver, and multiply into the ratio 4, just determined. Thus, assuming a 30 gear, the second driven would be $30 \times 4 = 120$, the gear to be put on the lead screw, with the other gears as shown in sketch No. 2.

Take another example. Let the lead have pitch 4, and the screw to be cut 32. The simple gears would then be 20 and 160. Select any gear for first driven, say a 60, and divide into 160, i. e.,

$\frac{160}{60} = 2 \frac{2}{3}$. Then select any gear for

60 second driver, say a 30, and multiply by $2 \frac{2}{3}$, giving $30 \times 2 \frac{2}{3} = 80$. Therefore, the arrangement would be 20 into 60, and 30 into 80.

PARALLEL BORING ON LATHE.

By J. H. R., Hamilton.

The accompanying sketch shows an attachment placed on a lathe for boring two or more cylinders in the one casting at practically one setting, having their axis parallel with one another. The compound rest is removed from the cross slide S, and the attachment placed on and secured with bolts similar to the compound rest.

The tapered block A is planed to an angle so as to bring the centre line of the cylinders as near as possible to a horizontal position. Any error of adjustment in vertical setting can be taken up by moving block B along block B' with the screw E; the nut N being secured to table block B. By the use of the graduations the table can be moved to any desired angle in the horizontal plane.

By the use of small centre heads (similar to those on a milling machine) and other jigs many small jobs often met with in a small repair shop can be successfully handled.

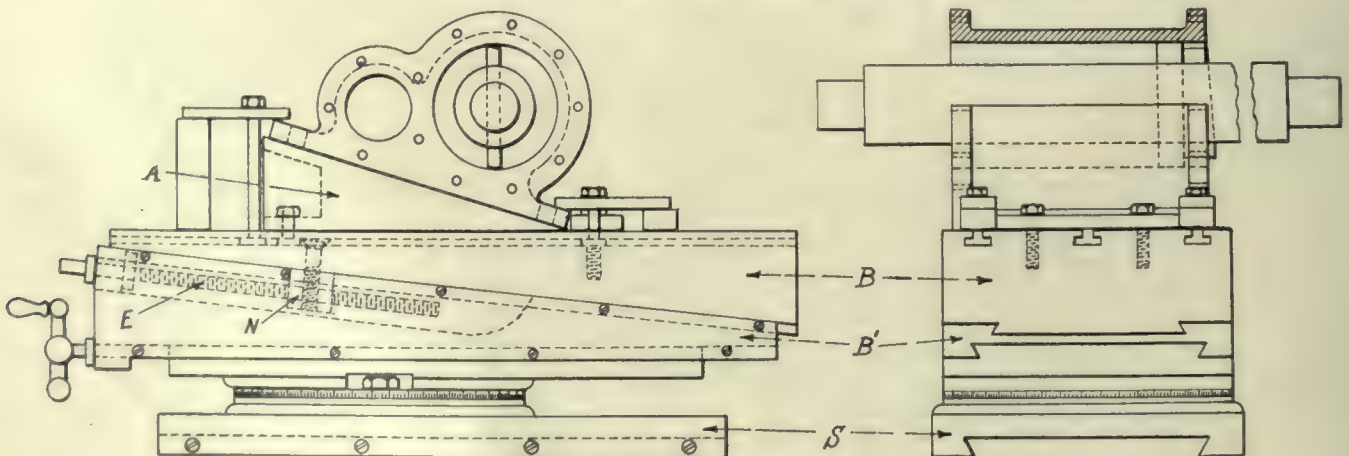

Parallel Boring on a Lathe.

Example.—Let it be required to find the proper gears to cut 10 threads per inch on a lathe having a lead screw pitch of 4, and change gear ratio 5.

any gear, say a 50. Dividing 200 by 50 this — gives a ratio of 4. Then select

By fitting the lower block B' directly to the saddle in place of slide S, the attachment could be made much heavier for larger work.

BALL BEARING COUNTER.

Ball-bearings, while presenting very few difficulties in counting, when in large numbers, take a lot of time, if counted in the usual method by hand. Being smooth and slippery they have a great tendency to drop from your hands, spoiling the count.

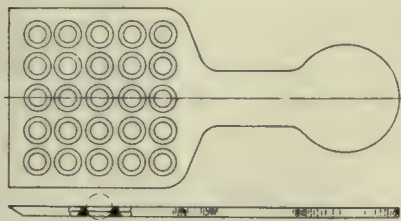

Ball-Bearing Counter.

The London Machine Tool Co., Hamilton, use a large number in their thrust bearings. As necessity is the mother of invention, one of the men devised this simple little device, by which they can be counted very expeditiously. The counter is a soft steel plate, riddled with countersunk holes, located as closely together as practicable. When scooped into a dish of balls, the holes become filled, one in each. While the surplus run off, the holes being of such a depth that no good resting place is provided for the surplus balls. As there are 25 holes, each scoop means 25 balls, so by counting the dips, a rapid count is made, as well as making the operation easier for the mechanic, as nothing is so monotonous as a long slow count such as is necessitated by the usual method.

Different sized counters are provided for the various sized balls, as the holes are made but slightly larger than the balls for clearance.

Brass would be a preferable material for the counter as no damage to the balls could possibly result.

REMOVING CAST IRON CHIPS.

By M. E. D.

I was watching a mechanic instal an engine recently, and saw him make good use of a magnetized pocket knife. The

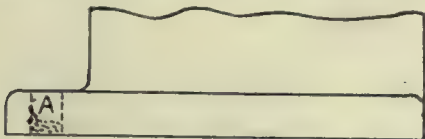

Removing Cast Iron Chips.

little kink may be used conveniently by other mechanics or engineers, when there is a blind hole to be drilled and tapped.

In reaming out the hole as shown in sketch, the chips of iron collected at A. Without stopping for explanations the mechanic drew his pocket knife, which had previously been magnetized, from

his pocket, and quickly removed the chips from the hole.

As it is an easy matter to have a knife magnetized, this fact can be made of general use. For instance in drilling the holes for the stud bolts for engine bearing the kink could be used very conveniently.

JIG FOR ACCURATELY BABBITTING BEARINGS.

A large Canadian wood working machine company manufacture a grinding machine for sharpening cutter heads, etc., and which has an adjustable table much the same as a vertical miller, with the exception that the shaft rises and falls in front of the shaft instead of at right angles as in a miller.

To be correct, the shaft must be parallel to the face of the adjustable table and also to the face on which the table rises and falls. Thus, the shaft must be

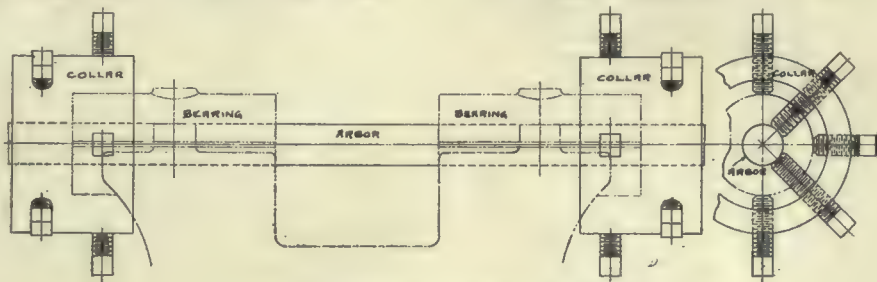

Jig for Automatically Babbitting Bearings.

adjusted correctly in two planes. This would be a simple matter if the bearings were bored in a mill, but as they are of babbitt, with no machining, the babbitting arbor must be set to correspond to the final position of the shaft. This is accomplished as shown in the cut, by attaching collars to the outer ends of the bearings with set screws, and adjusting the arbor with another set of set-screws. Adjustment into any desired position can be made, the extent of the adjustment being determined by a surface gauge on the table, and also on the table slide. It is a very useful appliance, and might be adapted to other work equally well.

REBORING CYLINDERS.

Barkey Bros., Stouffville, are frequently called upon to re bore traction engine

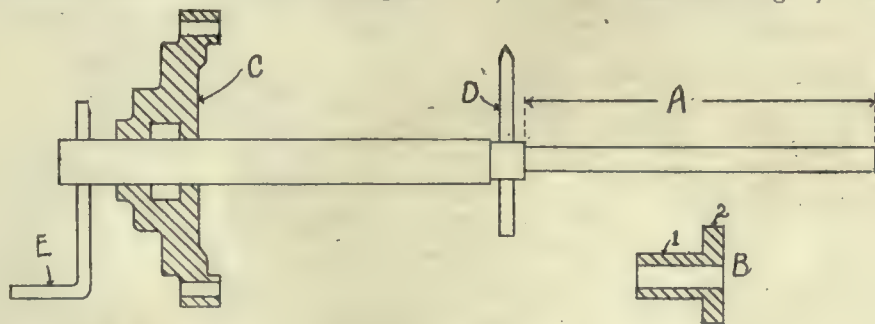

Cylinder Boring Bar.

cylinders, and as it was a big job to remove the cylinders to machine them in a lathe, a cylinder boring bar was designed which greatly facilitated the work. By using it, it is not necessary to remove the cylinders from the boiler, and a cylinder can be bored and the engine made again ready for service in three hours.

Referring to the drawing, A is the feed screw threaded at 44 threads to the inch. This runs in the casting B which is threaded the same. At 1, this casting is turned the size of the piston rod, while at 2 it is turned the size of the packing gland. When it is inserted into the piston rod end of the cylinder, the stuffing box is crowded on.

The casting C slips on the rod, fits closely, and is bolted to the cylinder head, taking the place of the cylinder

head. The tool is fastened at D, a straight tool being used for the main body of the cylinder, and an offset tool for recessing the ends of the cylinder. E is the operating handle.

HEADING TOOL.

For the large Bucyrus shovels that they make, the Canada Foundry Co., Toronto, require many feet of heavy chain such as is shown in Fig. 1, which is made of standard pieces cut from 3/4 inch x 2 inch wrought iron flat bar. The pins are from 3/8 inch iron bar stock.

These pins are cut the requisite length; and then riveted over with an ordinary machinist's hammer which, of course, gives a very rough finish.

To finish up in better shape, a special tool, such as is shown in Fig. 2, is em-

ployed. This consists essentially of a steel body containing steel rollers on a pin. The body fits the spindle of a drill, so the work can be put on the drill table. The steel rollers which are hardened are pressed down on the roughly riveted pin, and thus smooth the surface down by rolling. Pressure is exerted from the drill feed mechanism. As the rollers turn in opposite directions, a thin brass washer is inserted between

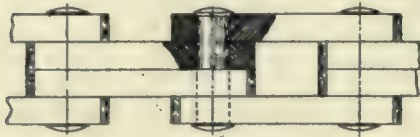

Fig. 1.—Dredge Chain.

them. All the pressure is upward and outward and to prevent undue friction from the latter balls in ball races on either side are used. The pin on which the rollers turn is hardened to take up the wear.

The tool is put together by first filling one ball race, then introducing the corresponding rollers, turn over, fill the other race, introduce the other roller, and next place in washer, finally putting through the centre pin.

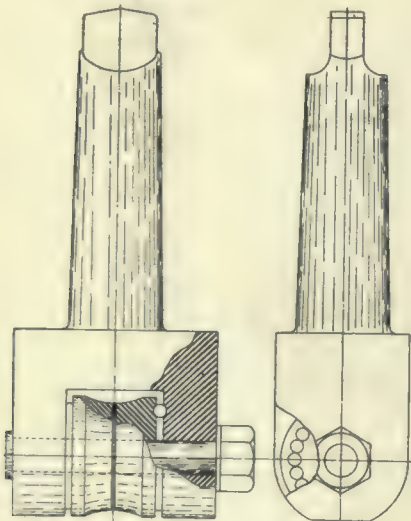

Fig. 2.—Heading Tool.

Results from the use of this tool are excellent, but the wear and tear on the drill, is very great, causing the spindle to run hot most of the time.

PNEUMATIC TOOLHOLDER.

The C. P. R. have successfully applied a pneumatic tool to Bertram lathes for turning car and truck wheels. In turning wheel tires it is necessary to change the tools three times for each tire and two men were required to operate the tools. With the tool shown, one man can operate them, the necessary champing and setting be accomplished almost simultaneously.

The toolholder shown was used on a 36 in. lathe. Forty pounds air pressure, in connection with the levers in the toolholder, holds the tools rigidly. High

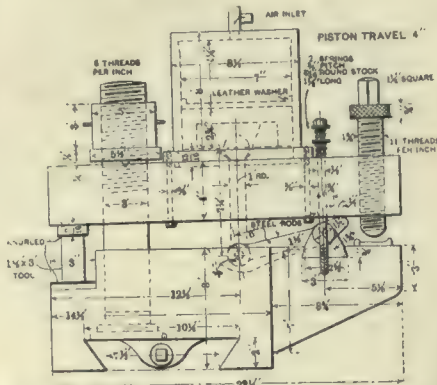

Pneumatic Toolholder for Bertram Car Wheel Lathe.

speed steel tools 3 x 1 1/2 in. were used and a surface speed of 17 ft. per min. with a cut 1/2 in. deep and 1/2 in. feed per revolution.

PROTECTED ROLLER BEARING.

Sheldons, Ltd., of Galt, have an especially good brick car, metal construction throughout, as shown in Fig. 1. The major part of the car is composed of standard steel shapes.

The journals form the most interesting feature, for not only are they rol-



Fig. 1.—Steel Brick Car.

ler bearing, but they are so constructed as to be protected from the dust, which is so injurious to machinery around brick plants.

From Fig. 2, it will be seen that the journal consists of a large cast iron shell, secured to the running gear of the truck by bolts, within which is a chilled cast iron bearing, which holds the rollers for the shaft. On the shaft is a

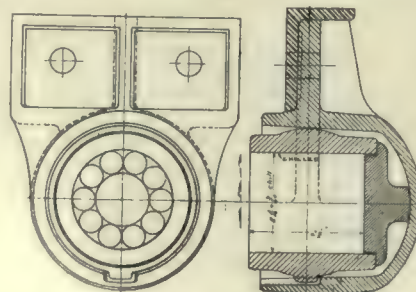

Fig. 2.—Protected Journal of Brick Truck.

collar, flush with the chilled cast iron ring, thus completely closing the rollers from dirt and grit in a very effective manner.

HANDY HOOK.

By F. J. Deegan.

A handy quick action hook is here shown, and is an idea that should be found very useful. The writer devised it for hanging up time check boards.

The device consists of a weight A, on the end of an arm B, the latter pinned at C. A stop block D prevents this rod B dropping back too far, keeping it level. Any object to be suspended is placed in slot E, first lifting A so that

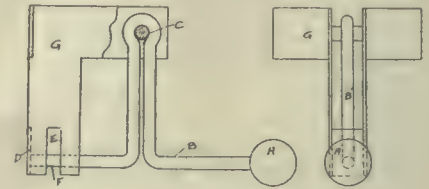

Handy Hook.

pin F may be inserted in the article. Weight A must be sufficient to more than counterbalance the weight of the suspended article. The bracket G for holding the device can be made of almost any material.

ADJUSTABLE PISTON VALVE RING.

The engine at the McLachlin Mills, Arnprior, has a piston valve, made by the engineer, Geo. H. Johnson, which is worthy of notice, from the fact that precautions have been taken to look after the natural wear.

The piston valve, a section of half of which is shown in the cut, consists of

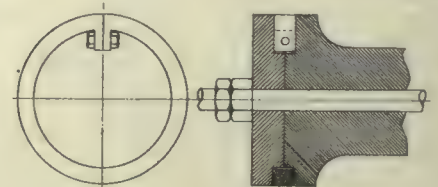

Piston Valve Ring.

three sections—the body and two end pieces, the latter, with the main body, forming the annular grooves for the piston valve rings. This ring is unique in construction, as shown by the end view, as it consists of a single piece, bolted together at the top, the bolt flange fitting into a similar recess in the piston valve.

The idea of the split and bolted construction is, that the ring, after becoming slightly worn, may have paper or tin shims placed in the cut, and clamped in position, the ring then assuming a practically circular form again. Satisfactory operation seems to have resulted from its use.

DEVELOPMENTS IN MACHINERY

New Machinery for Machine Shop, Foundry, Pattern Shop, Planing Mill; New Engines, Boilers, Electrical Machinery, Transmission Devices.

GARVIN MILLING MACHINES.

About two years ago the Garvin No. 14 vertical milling machine was described in Canadian Machinery, but several recent improvements on this miller, as well as some of their others will be of interest to our readers. The improved No. 14 miller is shown in Fig. 1.

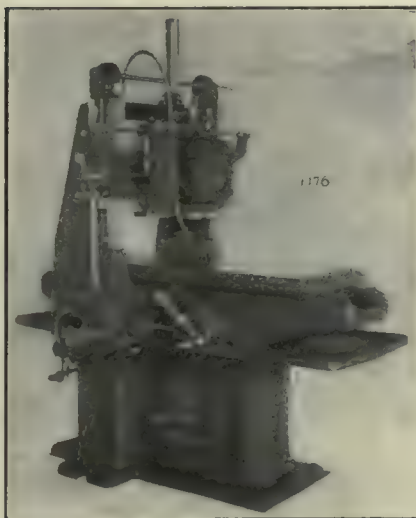

Fig. 1.—No. 14 Garvin Milling Machine.

The standard rotary feed box used by the Garvin Machine Co. on their milling machines, has been adapted to the requirements of the No. 14 vertical spindle milling machine. This gives twelve changes in geometrical progression, with the addition of a reverse, so as to change the direction of the feed. This feed box carries both direct to the head on the rail, or to the table feed. Should the feed for one need to be different than the other, the quick turning of the crank while the machine is in operation will bring the desired feed into play. The table and rail feed are automatic in both directions. The automatic trip to both is of a character, in which the feed is thrown out a trifle before the positive stop is reached, so that there can be absolutely no breaking down of the feed works by carelessness in setting trips.

The change of back-gearing in the spindle head is now made by one lever, throwing the gear through as in automobile practice. There are three positions for this lever; two for the back-gearing ratio and one neutral, and when in this neutral position the universal joint drive shown on the back-gear shaft can

be disengaged and attached direct to the spindle, giving high speed without gearing.

On the No. 1½ has been added a motor mount shown in Fig. 2. The feature of this is to have a mount that can be attached to a machine in stock, thus avoiding the expense and delay in covering the motor drive requirements.

The motor can be mounted, as shown in Fig. 2, or on a bracket at the rear of the machine—preferably the latter, as it makes the entire outfit portable. The impression that the power of the machine is deficient on account of the short center distance between cone pulleys, is erroneous. The high speed, narrow belt drives on to a two speed cone, which back-gears to the main cone through a double back-gear system, giving eight changes each of speed by belt or gears, totaling sixteen changes of speed. Both overhead cone pulleys run on a stationary shaft stud, that is made hollow to allow of supplying the lubricant from grease cups at both ends. This shaft is keyed to the eccentrics, one of which has a segment worm gear under control of a crank. This scheme is used to give the proper tension to the belt, allowing of easing it off for shifting purposes. No other lock is necessary to retain the belt tension. It is this point of belt tension that keeps the machine up to high productive ability. The feed from the spindle to the rotary feed change box is by chain, and other points of the machine have been clearly set forth in our columns in the year past.

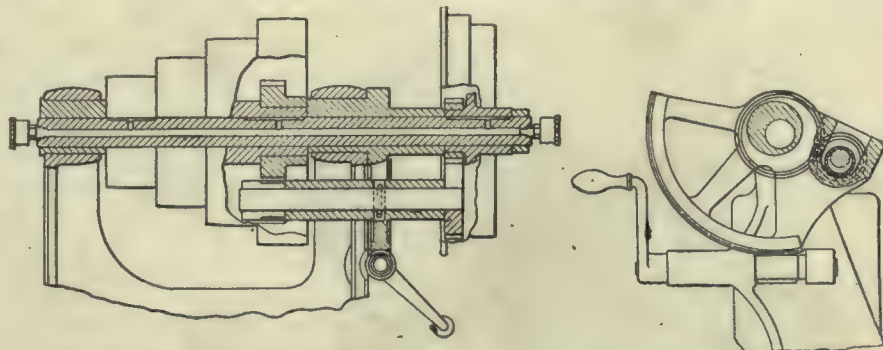

Fig. 3.—Detail of Drive and Belt Lightener, Garvin No. 1½ Milling Machine.

The weight of this machine is 2,450 lbs.

The attachment shown in Fig. 4 was designed for general work in milling pieces that require a quartering index. The illustration shows the attachment holding what is known as a lathers'

hatchet, where the head is grooved at right-angles, producing a checkered face. It is also adapted for squaring shanks of taps, reamers, bolts, studs, and similar work.

As shown for milling hatchets, the work is inserted into the fixture, under the height gauge. It is a four division index fixture, locking by means of a belt. After the hatchet is put under the

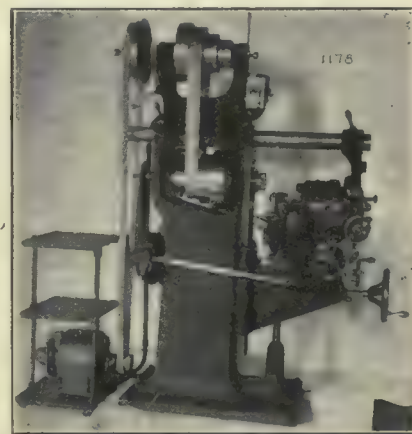

Fig. 2.—No. 1½ Universal Milling Machine Motor Mount.

gauge, and clamped by means of a binder, it is revolved one-quarter of a revolution, and passed under the cutters. After having passed once, it is revolved another quarter of a turn, and passed under the other cutter, these two passes completing the squaring operation. Once the fixture is loaded with four hatchets, each passage completes an operation.

For squaring shanks of taps, reamers, etc., the half-bushings for holding the work are interchangeable and quickly removed; and in all cases, it will be noticed that the cut is against the fixture, the clamp just holding the work



Fig. 4.—Attachment for Milling Pieces Requiring Quartering Index.

into the bush. The index ring is of large diameter, and the locking bolt is a long well-fitted bolt, operated by the handle on top of fixture. The entire fixture swivels on a standard that has a fit to the extreme top. The rotating casting fits over this standard in such a way that chip troubles are entirely eliminated.

The attachment is shown on a No. 21 back geared milling machine. The weight of the fixture is 125 pounds; and it is of such design as will easily go onto any medium sized milling machine.

These milling machines are manufactured by the Garvin Machine Co., Spring and Varick Sts., New York.

TRIPLE GEARED SHAPER.

The accompanying illustration shows a new 26 inch triple geared shaper. The ram of the shaper is driven by two rack gears of large diameter, and the rack is cut from the solid steel bar. The teeth in the rack are staggered, thereby avoiding the excessive jarring at each end of the stroke, and giving an even pushing strain on both gears. The use of two gears permits the passing of bars through an opening in the top of



Steptoe Shaper.

the column for key-seating, which cannot be done where only one large gear is used.

The plate for shifting the belt has eccentric slots so arranged, that one belt is shifted before the other, thereby avoiding excessive squealing.

The head can be very quickly loosened and swiveled to any angle by pushing the lever at the back of the head, and can again be instantly fastened by pulling the lever toward the operator.

The shifter dogs are placed on top of the ram in a very convenient position, and thereby permits a ram of larger and stronger dimensions.

The table support is provided with a roller, which slides on a plane surface under the table, and can be very quickly adjusted by means of the lever shown.

This machine is geared at the rate of about 42:1, and is made to take very heavy cuts with high speed steel. The column, ram and base are very heavily ribbed and braced, and all bearings are made very heavy.

The vise has a graduated swivel base, which is turned at any angle of thirty degrees, so that it can be easily read by the operator. The upper jaw of the vise grips firmly around the lower jaw, thereby preventing the upper jaw from raising when the work is being tightened in the vise. Two additional clamping bolts are provided which project through the upper jaw of the vise, and which can be fastened where extreme accuracy is necessary, as these bolts will overcome the tendency of the upper jaw to raise when the work is being clamped.

This shaper is manufactured by the John Steptoe Shaper Co., Cincinnati, Ohio.

NEW DRIVE FOR FLAT TWIST DRILL.

The questions connected with using and driving twist drills, forged or twisted from flat bars of high speed steel, are probably receiving more attention from mechanics at the present time than any others connected with the use of tools. Although attempts to solve the problem of drive have been numerous—more or less complicated chucks have been designed to hold and drive the rough end of the flat bar of steel; the shank ends of the bars have been spirally twisted and machined to form taper shanks fitting regular taper sockets; more or less cumbersome taper shanks have been soldered or riveted to the shank ends of the flat twist drills—none of these methods has seemed to settle the matter beyond the possibility of further question.

The Cleveland Twist Drill Co., of Cleveland, Ohio, have recently applied for patents on a new device for driving

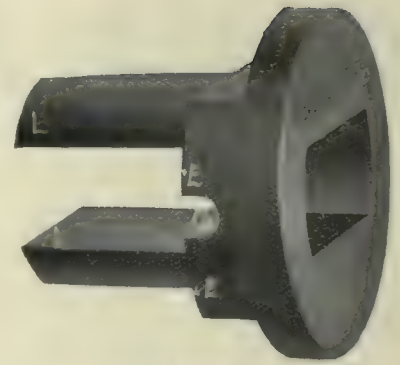

Fig. 1.—Hard Service Drill Socket.

flat taper shanks that are tapered both on the flat sides and round edges. These shanks are regularly furnished on this company's "Paragon" flat twist drills, and are driven by sleeves or sockets in-

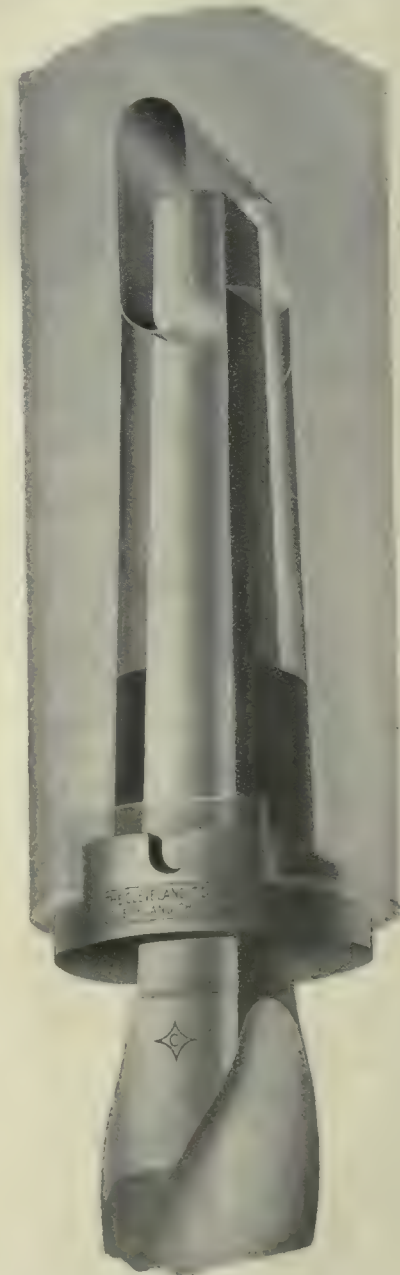

Fig. 2.—Shank, Collet and Spindle in Combination.

ternally equipped with flat taper holes accurately fitting the shanks and externally tapered to fit standard taper sockets or spindles. In the case of large diameter flat twist drills having No. 6 shanks this drive was found to have certain disadvantages, as it made necessary the use of cumbersome extension reducing sockets to adapt the large shanks to the drill press spindles which seldom have a taper hole larger than No. 6. To overcome this difficulty, as well as to provide additional driving strength, is the two-fold object of the new device.

To this end both the No. 5 and No. 6 "Paragon" blanks have been redesigned the same length as regular taper shanks, the taper on the round edges being regular Morse taper as formerly. When therefore this modified shank is inserted directly in the spindle the upper end of the shank is received and driven by the flat slot in the spindle just as is the tang of an ordinary taper shank drill. This alone would constitute a strong and practical drive but for the lack of support the shank would have on its two flat sides at the lower end of the spindle. To provide against the resultant possibilities of vibration and wear between the shank and spindle, and to furnish a powerful additional drive at the lower end of the shank where its cross section area is greatest, a new and original type of socket, called the "Paragon" collet, has been evolved.

As shown in Fig. 1 the collet consists of two lugs (L,L) projecting upward from a flattened disc, through which is cut a rectangular hole to receive the "Paragon" shank. The lugs have rounded outside surfaces ground to standard taper and flat inner surfaces tapered to fit the flat taper shank. The groove (g) is provided to receive the point of a drift key in case the collet should stick in the spindle. When the

collet is on the shank the combination is practically an interchangeable taper shank with unusually long tang.

Fig. 2 shows the shank collet, and spindle, in combination. The additional drive is provided by means of an extension (E) projecting (upward—in the case of vertical drilling) from the circular base of the collet. This projection mortises into a slot cut across the end of the spindle conforming to the standard slots now being put in the spindles of heavy duty drill presses by several well known manufacturers. That this tongue-and-groove drive at the large end of the shank is very much stronger than any drive on the tang could possibly be, is made evident by a single glance at the figure. The collets without this extension will fit any spindle or socket, and will be furnished to those whose spindles are not fitted with slots, when this requirement is plainly specified, but they will, of course, not have the additional driving strength otherwise afforded. With the extension they make what would seem to be an almost ideally perfect drive for the large sizes of flat twist drills.

"HARD SERVICE" DRILLS AND REAMERS.

The illustration presented herewith shows one type of "Hard Service" electrically operated Drills, manufactured by the Electrical Department of The Van Dorn & Dutton Co., of Cleveland, Ohio.

This company, in view of the extensive adoption of electricity for power and

lighting, early realized the demand for portable electrical tools that would stand the abuse of rough handling which machines of this character usually receive in the hands of inexperienced workmen. In response to this demand they brought out the first types of "Hard Service" drills and reamers. In detail these from time to time have been improved as the opportunity was afforded. Final simplicity, of course, is only reached by a process of elimination.

"Hard Service" machines are now built in six sizes, scope 0 to 2 in., and may be had for direct current either 110 or 220 volts.

A four pole straight series motor entirely form wound which is in reality a miniature railway type motor, designed to stand up under the varying loads and overloads which are bound to obtain, is employed. A feature worthy of notice is the large commutator which is proportioned three bars to each of the armature coils, which are composed of three single coils. This ample commutator service distributes the current so evenly that there is no sparking even under extreme load. The use of this construction insures the maximum production from the drill operator.

In view of the increased demand in Canada for an efficient tool of this kind, The Van Dorn & Dutton Co. have recently selected as their Canadian Representative, Mr. R. E. T. Pringle, located at Eastern Townships Bank Bldg., Montreal, P.Q..

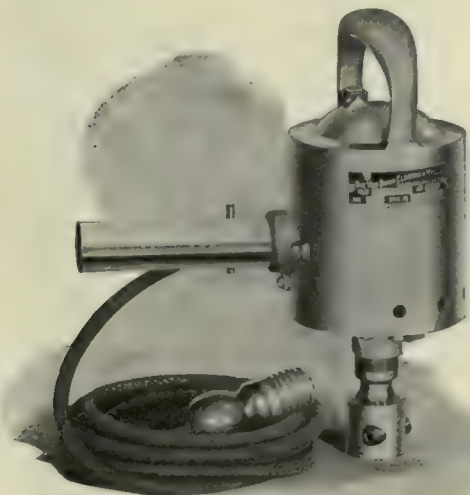

Hard Service Drill.



Hard Service Drill.

CANADIAN MACHINERY

AND MANUFACTURING NEWS

A monthly newspaper devoted to machinery and manufacturing interests mechanical and electrical trades, the foundry, technical progress, construction and improvement, and to all users of power developed from steam, gas, electricity, compressed air and water in Canada.

The MacLean Publishing Co., Limited

JOHN BAYNE MACLEAN, President W. L. EDMONDS, Vice-President
 H. V. TYRRELL, Toronto - Business Manager
 G. C. KEITH, M.E., B.Sc., Toronto - Managing Editor
 F. H. MOODY, B.A. Sc., Toronto - Associate Editor

OFFICES:

CANADA

MONTREAL Rooms 701-702 Eastern Townships Bank Bldg

TORONTO 143-149 University Ave. Phone Main 7324

WINNIPEG, 511 Union Bank Building Phone 3728

BRITISH COLUMBIA - Vancouver
 H. Hodgson,
 Room 21, Hartney Chambers

GREAT BRITAIN

LONDON - 88 Fleet Street, E.C. Phone Central 12960 E. J. Dodd

UNITED STATES

NEW YORK - R. B. Huestis
 1109-1111 Lawyers' Title, Insurance and Trust Building
 Phone, 1111 Cortlandt

FRANCE

PARIS John F. Jones & Co.,
 31bis, Faubourg Montmartre,
 Paris, France

Cable Address:

Macpubco, Toronto. Atabek, London, Eng.

SUBSCRIPTION RATE.

Canada, United States, \$1.00. Great Britain, Australia and other colonies 4s. 6d., per year; other countries, \$1.50. Advertising rates on request.

Subscribers who are not receiving their paper regularly will confer a favor on us by letting us know. We should be notified at once of any change in address, giving both old and new.

Vol. VI.

November, 1910

No. 11

ROOSEVELT'S RULE.

It is not the *critic* who counts—not the man who points out how the strong man stumbles, or where the doer of deeds could have done them better. The credit *belongs to the man who is actually in the arena, whose face is marred by dust and sweat and blood; who strives valiantly; who errs and comes short again and again, because there is no effort without error and shortcoming, but who does actually strive to do the deeds; who knows the great enthusiasm, the great devotions; who spends himself in a worthy cause; who at the best knows in the end the triumph of high achievement and who at the worst, if he fails, at least fails while daring greatly, so that his place shall never be with those cold and timid souls who know neither victory nor defeat.*—*Theodore Roosevelt.*

A SUBTLE FORM OF DISHONESTY.

From time to time there is in evidence a peculiar form of dishonesty which is the more dangerous in that it does not involve an indictable offence. This particular breach of probity consists in accepting a salary for filling one position while surreptitiously using a part of the time which should be devoted to the interests of the one employer to do work for and receive payment from another. A case in point is brought to mind by the newspaper notices respecting the firm of C. D. Sheldon. This man was accustomed to employ as stool-pigeons, men in responsible positions in various businesses, from government departmental employes in Ottawa, it is said, to men in financial institutions in various financial centres. It

is entirely unnecessary to comment upon the ethics of the tempter. The serious question is with respect to the lack of business honor which permits a man to sell his whole time to an employer, accepting a substantial yearly salary for same and then to steal part of this time for the purpose of increasing his income.

Where a man can, without lessening his value to his employer, devote his evenings to extra work, one cannot take exception to this method. The point in question involves a form of dishonesty which is often practiced by men whose integrity so far as actual cash or even finer points of honesty are concerned, is unexceptional. Cases of this sort come up more often than is generally realized and it is indeed time that steps were taken to protect an employer against petty and sometimes serious thefts of this sort, as against the more overt forms which involve the actual handling of cash. The government at Ottawa is endeavoring to prevent it, but the law is not yet of sufficient breadth to cover the ground.

A divided attention means lessened power of concentration and the opportunities of taking off a few minutes, or hours, of course increases with the responsibility of an employe's position. Should a man realize that by thus dividing his time and attention he is seriously lessening his earning power and consequently his value to his employer, selfish reasons alone would doubtless prevent much of such action.

THE BOSS WANTS TO KNOW.

If the boss wants to know, can you show him? If you are offered an advancement can you say you are ready. Are you taking advantage of the available opportunities? You can sit down on a stool and say you haven't the advantage of Technical Schools like the German or United States' mechanical men, that there was no apprenticeship system in the shop where you worked, etc. Do you think that will have any weight with the boss?

Are you reading your technical paper? Are you reading technical books on work which you are interested? Are you putting down on paper what you see in the shop, thus familiarizing yourself with shop methods? Are you trying to do a little more than you are paid for, or a little less? Ask yourself the question—"If the boss wants to know, can I show him?" Resolve to answer yes.

REPLACING OLD TOOLS WITH NEW ONES.

With the present developments in high speed steels and machine tools to use them, there is a greater output possible in great number of cases with machine tools of recent design than those of a few years ago. No doubt many plants are making money using less efficient and far from modern machinery. The product of a plant such as this, may have an excellent reputation and be in a class by itself. The output may be easily sold, the proprietors being content with large sales and small profits. It must tax the genius of the superintendent and foremen almost to the limit at times in some shops to keep the balance on the right side of the books. An observer cannot help but see how much more profitable it would be if the obsolete machinery were replaced by that of recent design.

If the management take the trouble to investigate where there is a large leak they will often find, that, by installing a modern machine, designed for the work it is to do, the machine will pay for itself in a few months. This has been revealed by fires, where old established plants have been wiped out and a new plant equipped with the latest design machinery erected.

It has been demonstrated in certain cases that the installation of a simple machine has reduced the cost very materially to even one-half or one-quarter of the previous cost. It has disillusioned the manager installing the machine of the idea of keeping in service a worn-out machine in cutting down costs. It will pay to make a comparative study of the capacities of the two machines, the old and the new. In this way it will be found which is the more economical and whether it will pay to retain the old machine or install a new one.

WASTEFUL ECONOMY

It is possible to be wasteful even in economy. A certain firm was some time ago persuaded to employ a system of accountancy which was guaranteed to prevent dishonesty on the part of employees. After due consideration the system was adopted and two additional men employed at a salary of \$700 a year.

At the end of the year it was found that one item amounting to \$5.75 had been saved. In other words they had spent \$1400 to save \$5.75.

System is necessary but system that saves at the spigot and wastes at the bung hole is an evil. It is system gone mad.

System is designed to economize and facilitate, not to waste and hinder.

THE RECIPE BOOK.

An alloy of 95 per cent. of copper and 5 per cent. of aluminum is the nearest imitation of pure gold of any of the known alloys.

According to the Foundry, the proper proportions of a copper alloy for soldering irons, copper hammers and all copper castings which do not require high electric conductivity, are obtained by mixing 96 pounds of copper and 4 pounds of zinc. Two tablespoonsful of salt should be added to the copper when first charged. The zinc should be added after the copper is melted. The mixture is thoroughly stirred and the metal is allowed to superheat for a few minutes before being cast.

An ingenious process of finishing high-speed gears has been proposed, its theory being that low spots in mating gears will be built up as the gears are run together. The method proposed is to electroplate the teeth with copper while running them in a suitable plating tank. The process is the direct opposite of the wearing-down process which, as every gear expert knows, is not conducive to the best results.—Machinery.

Experiments have now demonstrated the fact that the cause of the rapid rusting of steel and iron in the form of sheets, wire rods or tubing, is caused by the presence of impurities. By the elimination of manganese and other foreign elements in the iron, it has been found that it will withstand corrosion to a far greater degree.

The best lubricant for lathe and grinder centers is a mixture of powdered red lead (oxide of lead) and lard oil. When using this lubricant, if the oil dries out the centers do not cut, but simply take on a high polish. This mixture also works well for thread cutting, and a much smoother thread can be cut in tool steel than with plain lard oil.

In a parsimoniously conducted shop, the management refused to furnish lard oil for cutting purposes. The men discovered an efficacious substitute in the machinery oil that had been through the line-shaft bearings. The old oil which was removed from the drip cups proved an excellent lubricant for threading, etc.

To make a wax for metal patternmakers' use: Rosin, 11 part; beeswax, 1 part; plaster of Paris, $1\frac{1}{2}$ parts. Heat the wax and rosin and stir in the plaster of Paris, then add lampblack to make the desired color. Apply this wax with a heated knife. After taking an impression of a casting with plaster of Paris, by pouring molasses water around the edges, the plaster will be loosened so that the cast can be removed without injuring it. The molasses water will cause the plaster to stick to itself and not the pattern.—Scientific American.

The following formula will be found very handy for coloring brass a deep blue: Copper carbonate, 6.4 ounces; ammonia hydrate, 3,200 cubic centimeters; water, 1,600 cubic centimeters. The brass parts must be cleaned and freed from all grease. A good way to clean them is to dip them in gasoline. When clean, dip the brass into the solution, and let it remain therein about ten minutes. Then take it out of the bath and rinse in clear water. The brass will have a deep blue color, which will not tarnish or rub off.

Cast nickel-bronze gears are, according to Castings, employed in certain cases in which cast-iron gears have not the necessary strength and toughness, and cast-steel gears are unsatisfactory on account of their lack of uniformity. The alloy for these gears consists of 86 per cent of copper, 10 per cent. of tin, 3 per cent. of nickel, and 1 per cent. of 5 per cent. phosphor-tin. The nickel is melted with about 25 per cent. of the copper, after which the rest of the copper is added. Then the tin is added, and finally the phosphor-tin, the mixture being well stirred.

This lubricates the rams and valves and prevents packing from becoming hard:

Secure a clean, empty barrel. Into the empty barrel place 5 pounds sal soda (the addition of 5 or 10 gallons of hot water will readily dissolve the soda), then fill the barrel half full of water, agitating same, so that the soda and water will be thoroughly mixed and dissolved. When done, and not before, add 3 gallons of mineral lard oil. This mixture will turn white, resembling milk; then fill balance of barrel with water, mix well, and the solution is ready for charging the hydraulic system.—American Machinist.

In a paper presented before the American Society for Testing Materials, dealing with cupro-nickel steel, it is noted that alloys carrying from 5 to 20 per cent. copper, which without nickel would be extremely hard and brittle become, by the addition of nickel in proportion of 20 to 50 per cent., highly ductile and easily machineable.

To anneal steel having hard and soft spots, remove the scale, and heat slowly and evenly to a little above a dark red. Immerse in fresh water until almost cool. Heat immediately to a dark red and anneal in the usual way.

POWER GENERATION ^A_N^D APPLICATION

For Manufacturers. Cost and Efficiency Articles Rather Than Technical.
Steam Power Plants ; Hydro Electric Development ; Producer Gas, Etc.

What the Hydro-Electric Means to the Power User

Turning on the Power at Berlin, October 10, Marks the Beginning of Government Distribution of Power in Ontario--Power Equipment Exhibition at Berlin.

THE celebration at Berlin on October 11 marked the beginning of government distribution in Ontario. Among those present were Hon. A. Beck, chairman of the Hydro-Electric Power Commission; General Green president of the Ontario Power Co.; and F. H. McGuigan who had the construction contract.

The following municipalities have contracted for power in Western Ontario: Windsor, 15,000; Toronto, 10,000; London, 5,000; Guelph 2,500; St. Thomas, 1,500; Woodstock, 1,200; Galt, 1,200; Hamilton, Stratford and Berlin, each 1,000; Waterloo, 685; Preston, 600; St. Marys, Paris, Ingersoll, Brampton and Tillsonburg, each 500; Hespeler, 400; Mitchell and Seaforth, 300; New Hamburg, 250; Norwich, 150; and Sebringville 100.

Niagara Transmission Station.

The Hydro-Electric Power Commission have built the necessary transmission station at Niagara Falls for the distribution of this power. This transformer house is about half a mile back from the transmitting station of the Ontario Power Co., from whom all their power is obtained. The building measures approximately 45 ft. by 184 ft., and, as at present constructed, will accommodate half the contemplated final installation. This necessitated the erection of slightly over half the projected building, as the controlling end is complete, with one wing built north from it. A similar wing is to be built at some future date. The present building will accommodate 36,000 k.w.

Power is transmitted at 12,000 volt from the Ontario Power Co.'s transmitting station, through a tunnel, through oil switches in the basement, from which it is led to 3 banks of three 3,000 k.w. transformers delta connected on the low, and star connected on the high. These transformers raise the voltage to 63,000 volts across each phase, and as this high side is star connected, a line voltage of 110,000 volts is produced.

The centre of the distributing system is at Dundas seven miles from Hamilton. The total length at present installed is 290 miles.

Five districts will be served with hydro-electric power by the Hydro-Electric Power Commission. In addition to Western Ontario, there are Port Arthur in the north-west; Ottawa in the east; Prescott and Morrisburg in the east, and Belleville, Port Hope, Trenton, Napance and Kingston in the central district.

"Cheap Power."

This has been the result of the campaign for cheap power in Ontario. Power will be supplied at cost to the various

municipalities. A favorable manufacturing region of about 18,000 miles has been created in Western Ontario.

Exhibits at Berlin.

At the "turning on of the Niagara Power" at Berlin, were a number of exhibits of electrical machinery and supplies, the companies exhibiting being Chapman Double Ball Bearing Co., Canadian General Electric Co., Factory Products Co., G. C. Royce, Death & Watson, Holman Electric Sign Co., Federal Engineering & Supply Co., A. H. W. Joiner, Simplex Co., and Northern Electric & Mfg. Co., Toronto; Onward Mfg. Co., Berlin; and Canadian Tungsten Lamp Co., and Canadian Westinghouse Co., Hamilton.

Clutches Reduce Power Consumed in Machine Shop

By Using Clutches, Belts not Under Load Remain Idle, Loose Pulleys not being Necessary---They Reduce Consumption of Power, as Departments can be Disconnected when not in Use---Other Advantages.

MANUFACTURERS and their superintendents, master mechanics, and foremen, are finding that clutches result in a great many cases in a large saving of power. When not under load, the belts remain idle, and eliminate the continual stretch and contraction of belts while travelling around loose pulleys and their drivers.

They greatly reduce the consumption of power, as machines or departments can be disconnected when not in use, or shut down for repairs, without interfering with other parts of the plant.

They enable shafting or machines to be instantly stopped in case of accidents, and reduce the risk of accidents, by enabling all equipment not in use to remain idle, thereby improving the conditions of employes, and so assisting the employer to secure the most valuable help.

They enable motors and gas or gasoline engines to pick up their speed before the application of the load.

Lost Energy.

One of the important items of overhead expense in connection with every manufacturing establishment, is the annual power bill, and a large percentage of power is often expended on useless or lost energy.

Many machines consume more power in themselves than in the actual work they do, and these machines are not always provided with even loose pulleys. The friction between the loose pulleys

and the shaft consumes power, and belts, as they pass around the loose pulleys and their drivers, consume more power. The resistance of the air to the rotation of the pulley arms consumes a much



85 h.p. Clutch Made by Positive Clutch and Pulley Works, Toronto.

larger amount, and lastly the power consumed to overcome the friction between the shaft and the bearings is approximately 10 per cent. of the total con-

sumption. A manager would probably be astonished at the total of these items, and the cost of a clutch to disconnect that entire department from the main shaft would appear as a very small fraction of that grand total.

Again referring to the idle department; the loose pulley sleeves wear away and must be renewed, while the combined weight of shafting, pulleys, belts and belt tension shorten the life of the bearings. These repairs and renewals cost money for both labor and material, and very often necessitate shutting down the entire plant until they are completed. Then again all this running equipment requires lubrication whether in use or not. These are important matters, and the saving which would be effected in the upkeep and maintenance of plant is well worth the price of a clutch or two.

Positive Clutch.

The clutch shown in the illustration is one recently shipped to W. J. Baldwin, Aurora. It is an 85 h.p., running at 100 r.p.m. A similar one has been installed at the works of the Gendron Mfg. Co., Toronto. The gas engine is allowed to pick up its speed before the load is applied through the clutch.

The "Positive" clutch is a combined jaw and friction clutch. The load is gradually picked up by friction, the jaw giving a positive drive under load. The jaws are so constructed that in movement they are free from sliding contact and bear only when engaged, which also enables them to be freely withdrawn. When it is desired to disengage the clutch, the frictions take the load from the jaws before they commence to disengage. By means of springs the frictions and jaws are prevented from engaging or disengaging except by the use of the operating lever, while at the same time the springs are arranged to operate the jaws when the clutch is being engaged and disengaged. All parts of this clutch which run on the shaft are provided with permanent graphite lubrication. The pulley sleeves are made to standard diameters to correspond with the standard bores of pulleys and all parts made interchangeable, which enables a pulley clutch or clutch coupling to be converted into the other, or used on different sizes of shafts.

CUTTING BELT LACES.

By A. D. Scott.

Here is a little kink on splitting belt laces from the hide, or cutting a narrow lace from a wide one. In the sketch AA represent the jaws of a vise. B is a piece of board with knife blade C firmly driven in at a distance from the vise jaw equal to the width of lace required. D is the lace being cut.

The end of the hide, or lace, is first cut for three or four inches, as at E, then placed over the knife blade as shown, and pulled in the direction of the arrow, while the edge of the lace is

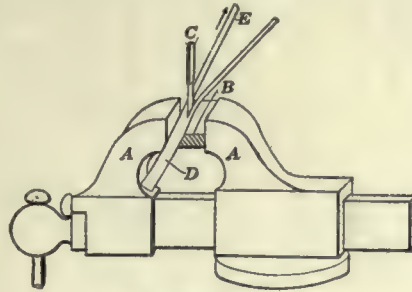

Cutting Belt Laces.

guided along the vise jaw. It, of course, requires two persons to do this.

Anyone who uses the lace-cutting device which slips over the fore-finger, and when in use nearly disjoints that member, will find this knife a real blessing.—American Machinist.

SIZE OF PIPE.

By W. Oelschlager.

An easy method to ascertain the size pipe required to unite two pipes into one, so that the one shall have the same

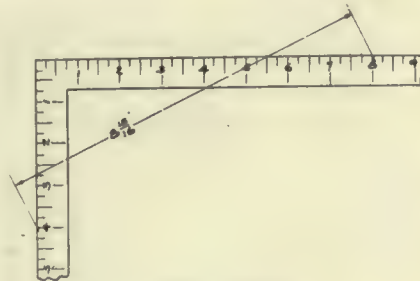

Size of Pipe.

area as the two. Say it is desired to unite a 4-inch and an 8 inch, take an ordinary carpenters' square, measure diagonally across with a rule from the 4 inch mark on the one blade to the 8 inch mark on the other blade, which will be about 8 1/2 to 9 inch pipe.

SAVING ELECTRICITY.

Tungsten lamps are coming to the front because they save electricity. In appearance, their only difference from the ordinary carbon filament incandescent lamp is that the filament is constructed of tungsten instead of carbon. But in actual use, it has been proved that they use only about one-third as much current as a carbon lamp to produce a light of the same illuminating power. True, their first cost is greater (approximately three times as much), but this is counterbalanced by the saving in current effected. They have one weak point, however. That is the ease with which the delicate

tungsten filament is broken. On this account great care has to be exercised in installing them, and it is for this reason, too, that they cannot be economically used as portable lamps. Yet, when carefully handled, they have a long lease of life. In England, where they are used much more extensively than here, it is quite common for them to last 3,000 hours, and one instance is on record where a tungsten lamp burned continuously for over 15,000 hours. Even when allowance is made for more frequent breakage, the tungsten lamp shows a saving over the carbon of about fifty per cent. That is an economy not to be despised and points to the much greater use for stationary lighting purposes.

BRAZING WITH KEROSENE.

By Frank C. Perkins.

The construction and method of operation of a kerosene oil torch designed for light brazing, wiping joints and similar heating operations may be noted in operation in the accompanying illustration. This portable blow torch is very efficient, producing an intense clear flame. It will be seen that the burner



Brazing a Cup Joint With Kerosene Lamp.

is mounted directly on top of the tank and was designed for the use of kerosene oil as a fuel.

The pump is fitted inside of the tank and the flame may easily be regulated. This torch is said to be more suitable for general shop work than the gasoline device and has an oil consumption of 1/2 pint per hour, with a capacity for 4 hours' service. A similar torch of a capacity of one gallon for greater heating service, has an oil consumption of three pints per hour.



Essentials of Success in Machine Tool Advertising

Selecting Mediums, Getting Inside the Shop, Filling Space, and Answering the "Whys"—A Careful Consideration of Machine Tool Advertising.

By T. S. Bentley *

It has been said that however good an article may be, three things are essential to secure its success, viz., 1st, Advertise, 2nd, **Advertise**, 3rd, **ADVERTISE**.

This forms a good example of the old proverb "there is many a true word spoken in jest." The words sound flippantly epigrammatical, but they embody a truth that has been proved times without number, and which must never be lost sight of by those who would secure and retain a leading place in any line of trade.

The subject of advertising is so vast and complex that whole books might be written about it without exhausting all its manifold phases. Such a treatise would be too elaborate to appeal to the ordinary advertiser, and its circulation would be very limited; nevertheless, a few practical remarks on this subject, addressed to the manufacturer and specially referring to the class of goods in which he is interested, may well prove both timely and suggestive.

The makers of machinery—and more particularly of machine tools—form such an important manufacturing class as to have literature all its own, with subdivisions which circulate for the most part in comparatively distinct and well-defined circles. This fact has an important bearing on the question under discussion, as it produces conditions entirely different from those which apply to general advertising in ordinary periodicals, or the daily press.

It will therefore be well to consider carefully some of the more important aspects of machine tool advertising, with a view to securing the best possible return for the money expended.

Selecting the Mediums

There are many considerations which influence, to a greater or less degree,

* Of Charles Churchill & Co., Ltd., London, in *Selling Magazine*.

the selection of the advertising medium that shall be employed; and it is of the most vital importance that their true relative value should be clearly recognized. Comparative cost is sure to weigh heavily in such deliberations—it is a matter which cannot be ignored—but it must not be allowed to overshadow other things which are really more essential to the advertiser's interests. It should never be forgotten that, whatever may be the case in other connections, in

is the cheapest," and the apparently cheap is in reality "dear at any price."

Having decided to select one of the best—and, therefore, most costly—advertising mediums, the question arises as to which of the leading journals shall have the preference.

Naturally, one with a large circulation will be favored (and this point is always made the most of by the advertising managers of the various journals;) but the essential thing is not the mere number of copies issued, but the number carefully read by those who are likely to purchase the tools offered. A paper with a large circulation among manufacturers and employers of labor, therefore, fulfills one of the essential conditions; but this is not all.

Getting Inside the Shop.

It must be borne in mind that there are many men in factories and workshops who, while never likely to be purchasers of machinery themselves, have a very considerable influence as to which of a number of competing makes shall be chosen for installation in the shops with which they happen to be connected. A journal which is not only popular in the office, but is also diligently studied by the workers in the shop is, therefore, of double value as an advertising medium. The number of publications which fulfill both of these conditions is so limited that the decision should be an extremely simple affair.

When the choice has been made and the space booked, the next thing is to study how to make the best use of it, so as to secure the maximum result from the outlay involved. Naturally, the conditions vary in every case, and each must be considered individually and on its merits. The kind of tools to be pushed; whether a single specialty or a line including some amount of variety; whether the goods offered are such as to call for a continuous demand from such as use them, or things which are bought once for all and seldom require to be duplicated in ordinary cases. All these things must be considered in the advertising.

The first object of an advertisement is to arrest attention. Unless it catches the eye readily, it will reach only a portion of those at whom it is aimed, and

THROW ON THE LIGHT

YOUR business principles may be right; your goods the best; your service to customers faultless

BUT THE PUBLIC HAS GOT TO KNOW

Keep always your talking points before the public. Get in the glare of favorable publicity. Make known the merits of your proposition.

Success comes by focusing the diverging rays of public opinion—centering buyers' choice on what you have to offer.

Make your ability, your commodity, your service **KNOWN**.

THROW ON THE LIGHT

the matter of advertising it is pretty certain to be the patrons of the bargain counter who are ultimately "sold." "The real worth of anything," says the proverb, "is just as much as it will bring;" and in the long run this dictum will be found to be very near the mark. Certainly, in the matter of payment for advertising space, the price charged generally bears a close relationship to the true value of its potential results. Thus it will be found that in this more than in almost anything else, "the best

FOUNDRY PRACTICE AND EQUIPMENT

Practical Articles for Canadian Foundrymen and Pattern Makers, and
News of Foundrymen's and Allied Associations. Contributions Invited.

HAND WHEEL PATTERN.

By H. J. McCaslin.

While visiting a neighboring pattern shop recently, a 15-inch dished hand wheel pattern, similar to that shown in

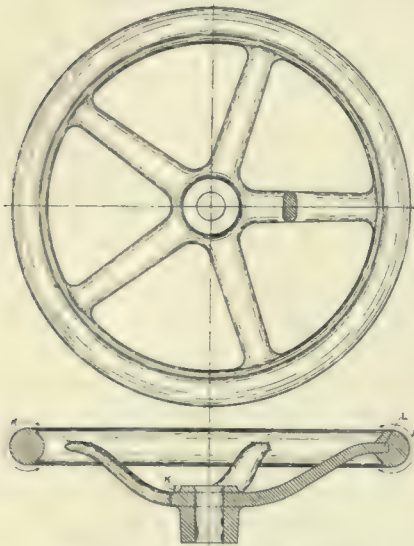

Fig. 1.—Handy Wheel Pattern.

Fig. 1, and which had just been completed, was noticed. In answer to an inquiry as to the length of time the job required, I was informed that 22 hours were expended in its completion. Remarking that I thought the time was a little excessive, attention was called to the manner in which the rim was glued

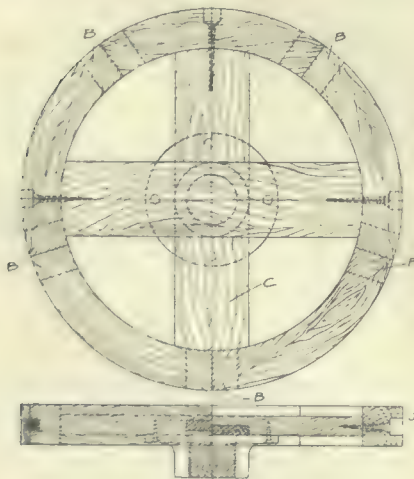

Fig. 2.—Handy Wheel Pattern.

up in three courses of segments, and the arms built in during this operation, and the time it took in completing the contour of the rim between the arms, that could not be turned.

Now, the man who put up the job was evidently a clean workman and put that much time upon the pattern, but did the job justify an expense of about \$8.25?

The incident left that impression that should a similar job come my way (which did sooner than was expected), it would not take as long a time to deliver the casting to the assemblers.

Cutting the Time.

My calculations did not go amiss, for a total of 17 hours was required in delivery and placing the wheel upon the shaft.

Nine hours were consumed in making the pattern, three hours in getting it through the foundry, and five hours facing and boring the butt and turning and polishing that portion of the rim shown at A, and smoothing up the arms.

This was not a break-down, or break-neck job to see what could be done, or by how much the other fellow could be beaten.

The job went through in the usual way, but with a little judgment and forethought in the making of the pattern, the before mentioned results were obtained, without any exertion.

As we made the pattern in 13 hours less than the case quoted an inscription as to how the job was handled might interest some of your readers.

Procedure.

First the rim was glued up, there being five arms and a similar number of segments. These segments were made the usual way and fitted together. Their abutting ends were then passed over the rip saw and scarfed for the insertion of a 1"x1½" tongue, as shown at B, Fig. 2.

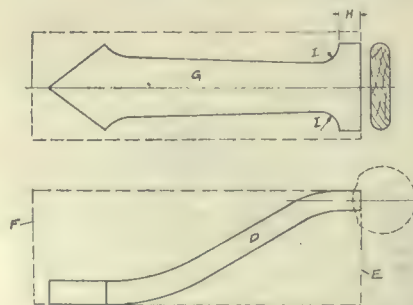

Fig. 3.—Handy Wheel Pattern.

The cross C shown in Fig. 2, was next roughly checked and glued together and put aside to dry, when the arms and hub next received our attention.

A full size plan and radial section of an arm and the rim, was next laid out upon ½" stock, which was subsequently cut out and used as a templet for laying out of the shape of the arms upon two faces of the blocks shown in Fig. 3. The elevation lines D, Fig. 3 of the arms were first sawed out, the sawed off material E and F lightly braded back in place, and the plan G of arm sawed out, leaving about a ½ inch tenent, as shown at H, for securing the arm into the rim.

With the exception of the filet I, the arms were rounded over and the cope and drag hub turned and the turning of the rim followed in order. The cross was carefully marked from the rim material, and so sawed that it would snugly enter the inner diameter of segments, in which position it was glued and a screw inserted from the outside, as shown at J, Fig. 2.

The advantage of using a cross in this way is that it permits the turning of practically the entire contour of rim without rechucking. For when the finished surface of rim has been extended from the front to the back of the cross the screws through the rim were removed and the turning continued by cutting into the cross. But before doing so, about ¼-inch of the rim contour between two arms of the cross was completed with the aid of a knife and templet. It will be readily seen that this finished section of rim, acted as a guide eliminating the stopping of the lathe to try a templet.

Now by following this pass or completed surface and alternately turning a little from one side and then the other, the rim was practically completed and separated from the cross.

Mortises were then marked off and cut into the rim as shown at L, Fig. 1, to receive the arm, by boring holes and cutting away between.

With that portion of hub shown at K blocked up to suit the disk of arm, the rim was centrally located about it and braded down.

The arms were then fitted into place one at a time, being glued into the rim and also together at the centre.

The last arm acting somewhat as a key to secure the spider in place.

The balance of the hub was next attached the fillets I worked into the rim and our job was ready to be varnished.

CLEANING MOLDS.

The accompanying sketch shows a simple device used in the steel foundry of the Ontario Iron and Steel Co., Welland, for blowing out dust, etc., from deep molds, which cannot be very well reached by the ordinary molding tools, owing to inaccessibility.

The device consists of three pieces of $\frac{3}{4}$ inch pipe, united by the T connection shown at C. The end A is connected to an air supply, and the ends B and D are left open. The arm ACB forms the handle, and the arm CD projects into the mold.

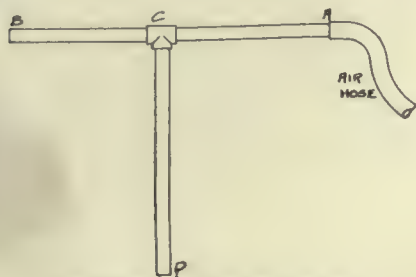

Apparatus for Cleaning Molds.

Either a blast or a suction can be created at D by proper manipulation at B. If air be allowed from A into the piping, it will rush across, through C and out B, creating a vacuum at D, the extent of which depends on the pressure at A, which is controlled by a valve. This will lift ordinary dust and small particles through D, and eject them at B. To remove particles in the mold by a blast, placing the hand over end B, diverts the flow of air, and sends it out D instead of B. The intensity depends on the extent of closure at B.

PREPARING CORE SAND

A new process of preparing core sand with a liquid binder has been developed by Jacob S. Robeson, of the Robeson Process Co., manufacturer of glutrin, Grand Mere, P. Q., and Au Sable Forks N.Y. Core sand mixtures, as generally prepared, lack uniformity and to effect a more intimate mixture of the liquid binding agent with the sand, the apparatus shown in the accompanying illustration is used. It will be noted that A is a sand drying chamber, fitted with a spout discharging into a hopper, from which it is delivered through a funnel-shaped spout to a rotary screen, B, which sifts the sand. This screen is so located that the liquid binder, in a finely divided state, may be discharged against and through the material as it leaves the screen. The tank containing the liquid binder is illustrated at C, and is provided with a pipe which delivers the binder to a discharge pipe connected with a blower. The discharge pipe has a flaring nozzle, E, through which the liquid binder, under the de-

sired pressure, is discharged in a fine stream or atomized condition, in a substantially horizontal plane, against and through the falling sand as it is delivered by the screen. Instead of a blower, steam may be delivered to the discharge pipe from a steam boiler, D, which is indicated by dotted lines.

The spraying of the liquid binder in a finely divided condition, either under air or steam pressure, results in such an intimate admixture of the binder with the sand that a smaller amount of the binder is required than in ordinary practice, and in addition, better results are obtained. Every grain of sand receives a coating of the binder, and the mechanical bond produced by this treatment of the sand is greater than that produced by adding the binder in the old way, and the saving in the amount

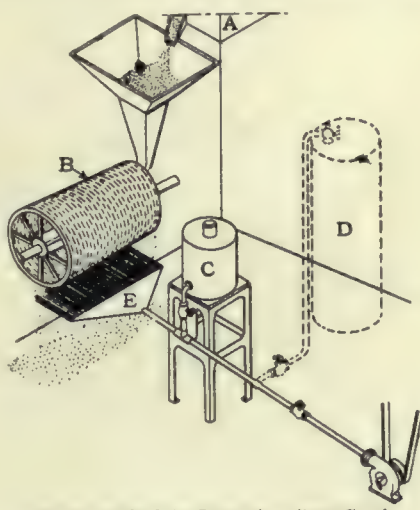

Apparatus Used in Preparing Core Sand.

of binder required approximates 30 per cent. Furthermore, a greater quantity of old sand may be used with such a mixture. While compressed air is preferred as the means for separating the binder and for mixing it with the sand, it may be possible, under some conditions, to use the binder in a denser state and to employ steam, under pressure, as the means of discharging it against the sand. This steam will carry such a content of water as will provide a given quantity of binder with an amount of moisture equal to that supplied in bulk, when compressed air is employed as the medium for discharging the binder against the sand. The difficulty, however, of determining this water content of the steam, and the danger of adding from such steam an excess of moisture which would seriously affect the adhesive quality of the binding agent, and consequently the character of the core, has led the inventor to prefer the use of compressed air. In most foundries both air and steam are accessible, and under the most favorable conditions, steam might be employed. The patent granted Mr.

Robeson not only covers the process as relating to the preparation of material for the manufacture of cores, but also for the manufacture of briquettes from coal, or other fuel, iron or other ores, etc.

IMPROVED EMERGENCY CUPOLA.

George Green & Co., foundry engineers, of Keighley, Yorkshire, England, have introduced a small cupola for melting from 1 to 10 cwts. of iron per hour. This cupola has already been taken up by a considerable number of foundrymen who desired to commence iron-founding in a small way, or wished to have at hand a small cupola which will cope at little expense with small heats of iron varying from 1 to 10 cwts. Ordinary foundry coke is used for fuel, and the furnace will produce molten iron at the spout about ten minutes after setting on the blast. The "emergency" cupola is very useful for test mixtures, and also for engineers who carry out repairs.

Mine managers will find it a great convenience in the event of a breakdown in machinery which needs immediate repair, in order to avoid disturbance of work and consequent loss. A mine is often situated a long distance from a foundry, and in such cases the "emergency" cupola is of special value, as it provides at small cost, coupled with

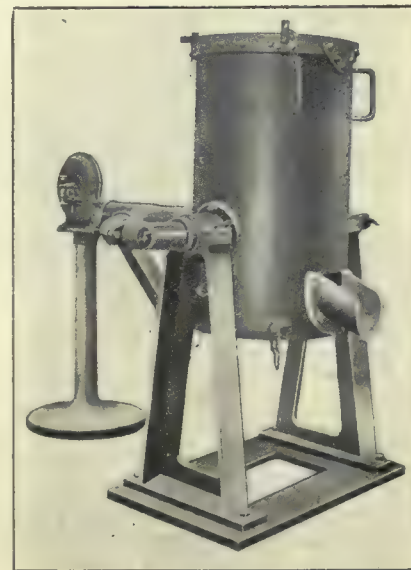

Improved Emergency Cupola.

great efficiency, the means wherewith to make a casting for repair work on the spot, without delay. The Taquah Mining and Exploration Co., Ltd., of West Africa are amongst the users of this cupola.

IMPROPER GATING OF COPPER CASTINGS.

We are making copper castings by the use of silicon-copper, and cannot get them clean, as dirt shows when the scale is machined off. We use ingot cop-

per, with two per cent. of silicon-copper and pour the metal hot. The castings are quite heavy.—Inquirer.

The dirt is caused by improper gating, and the fact that there is scale on the castings shows they are being poured too hot. Copper containing silicon is very fluid and does not need to be poured as hot as when zinc is used. It is very similar in casting properties to alloys containing aluminum, and has to enter the mold with extreme quietness to avoid the formation of dross. As we do not know the shape of your castings, it is difficult to advise as to how they should be gated. The following rules, however, can be applied in all cases: The metal should enter the mold at the lowest possible point and should always rise, never drop. The gate at which it enters can be quite small, the heavy portions of the casting being fed by risers, and sometimes the latter will have to be placed directly on the castings, as in the case of steel. A flat heavy slab, for instance, should have the mold steeply inclined, the metal being poured in at the lowest end, so that it gently rolls up hill and into a heavy riser, which feeds the casting and receives any dirt. Never gate such castings with two or more gates in such a manner that the streams of metal impinge. Therefore, change your method of gating and pour the metal cooler.—Foundry.

SPECIMENS WANTED FOR RESEARCH.

Knowledge of the true cause of globules in gas cavities, solidly encased shot iron, hard streaks or spots in castings, and white iron inside of gray or soft iron, is greatly required. The theories and suppositions of the past do not satisfactorily explain causes, nor tender positive remedies. A collection of samples containing the above defects accompanied with the following details of conditions, to enable a thorough investigation of the subject, which should prove of much value in assisting to obtain more accurate information than exists, are solicited by Thos. D. West, 10,511 Pasadena avenue, Cleveland, Ohio. Samples of defects and information requested as below will be gladly received from foreign countries as well as the United States up to the end of this year.

In forwarding any specimens information is desired upon the following points as far as practicable:

First, character of the pig and scrap, fuel and any flux used in melting the mixture, also state if anything unusual occurred or was observed during the heat. Grade of the iron produced in being soft, medium or hard, or better still an analysis of the casting.

Second, a rough sketch of the castings showing its form and thickness of the

different sections as far as feasible, also marking the location of the sample that is forwarded.

Third, whether the mold was green-sand, skin-dried, dry-sand or loam, and a description of the gating and pouring.

Fourth, whether the metal at the time of being tapped, as well as being poured into the mold, was "hot," medium or "dull," and any other information as far as convenient that might be thought of value in assisting an intelligent modern research of the subject.

The results of this investigation will be given to the trade through the medium of a paper to some one of our foundry or engineering societies.

PRACTICAL USE OF ABRASIVE WHEELS IN FOUNDRIES.*

The principal factor in the successful adoption of an abrasive wheel is a knowledge of the practical operating conditions under which these wheels should run for economical results.

The first essential in the successful adoption of a grinding equipment of any size is the disposition on the part of the management making the installation to operate under conditions to produce practical results.

Safety Collars.

The method of controlling the factor of safety to the operator should be determined, whether by safety collars, which are tapered if possible on the concave side $\frac{3}{4}$ inch to the foot, so that the wheels may be tapered convexly accordingly. In this case, where the nature of the work will permit, the maximum amount of wheel exposed beyond the edge, or rim, of these collars should be 2 inches and the collars changed as the wheels wear; or by the use of substantial hoods in cases where it is necessary to use wheels with straight sides, owing to the nature of the work to be ground, or by the use of both hoods and collars. Wherever possible, the general results will be more satisfactory, when the safety collars are used. If a wheel breaks in service, these collars, which should be at least $\frac{3}{4}$ -inch thick and made from cast steel for wheels 24 inches in diameter, will hold the pieces together.

Grinding Stands.

After determining the size of the wheel, it is necessary to have machines solidly set on good foundations with a heavy spindle in long bearings that can be kept well-lubricated, having all vibration eliminated when carrying the load of the wheels with the additional weight of the heaviest safety collars that are to be used. For a 24x2-inch wheel, with

* Abstract of a paper presented at the October meeting of the Pittsburg Foundrymen's Association.

these safety collars, the spindle should be at least $2\frac{1}{4}$ inches between the flanges where the wheel is mounted, and for 24-inch wheels heavier than this, the spindle should be at least $2\frac{1}{2}$ inches diameter and the bearings not less than 12 inches long. This applies to floor stands for foundry practice, especially where the work is of a heavy nature. In addition to this, in all steel foundries, excepting crucible plants where nothing but very small castings are made, and many malleable iron foundries where there is sufficient work of a heavy nature, the most economical machines that can be installed are swinging frame grinders. These machines should be driven with flat belts, having a spindle at least 2 inches in diameter, for carrying 18, 20 or 24 inches wheels. The wheel spindle should be driven by at least a 4-inch double belt.

Power.

After investing in this equipment, ample power for driving these machines should be provided to keep the wheel operating under the proper speed, while it is at its highest pressure of service. On the floor stand, operating two 24-inch wheels, where two men are working, 10 horse-power should be provided, and on a swing frame grinder, operating one 20-inch wheel, 2 or $2\frac{1}{2}$ inches face, if driven by belt power, the countershaft should be driven by a 6-inch belt. In operating one of these machines, with a motor connected to the countershaft, which must drive the belt and absorb the friction necessary, not less than a $7\frac{1}{2}$ horse-power motor should be used, preferably 10 horse-power; but where the motor is mounted on a bracket at the elbow of this machine, the belt being connected direct from the motor pulley to the pulley on the wheel head, a $7\frac{1}{2}$ horse-power motor is ample, and in some cases 5 horse-power has proven entirely satisfactory.

Operating Speeds.

To the adoption of the safety collar is accountable economical operating conditions more than to any other factor, in that it has enabled the adoption of speeds which bring results with safety. The practical safe limit for running abrasive wheels with straight sides is 5,000 feet per minute peripheral speed, and even then it is quite hazardous unless these wheels are carefully protected with hoods. With the safety collars properly used, one can operate more safely at 6,500 feet per minute peripheral speed than to operate the straight wheels at 5,000 feet, with the additional advantage of an increased output. Those operating in accordance with these suggestions will secure the highest degree of efficiency obtainable in foundry work, and the writer's experience has been that 6,500

feet has proven to be the most economical speed at which to run.

Cup Wheels.

The use of cup wheels, sometimes called tub wheels, should, at all times, be avoided. They are the most dangerous of abrasive wheels and in their stead, where it is necessary to do face grinding, a good substantial chuck should be used, with a cylinder wheel which has no back. It is apparent that a cup or tub wheel, which, for instance, may be 12 inches in diameter, 6 inches high, with 2 inches, or more, thickness of rim and a back 1 or 1½ inches thick, that the centrifugal strain of this heavy rim pulling on lighter binding point, compels the running of these wheels very slow to keep within any reasonable lines of safety. Were this made without the back, and the cylinder completely surrounded with an adjustable chuck whereby the wheel can be fed forward as worn, a higher speed might be maintained with perfect safety. A cup wheel should not be run more than 3,500 or 3,800 peripheral feet per minute, depending on the thickness of the rim, whereas a ring wheel may be run approximately 5,000 feet per minute.

PATTERNMAKER'S SAWING CLEAT.

By K. Campbell.

Sometimes a pattern maker does not find it convenient to use a vise. In some



Patternmaker's Sawing Cleat.

cases a pair of patternmaker's sawing cleats will be found very handy. The cleats can be made of any convenient size and consist of one board on which are blocks, one at each end on opposite side of the board.

At the foundry of the Fort Wayne Electric Works rain water in a closed piping system is circulated through the water jackets of the air compressors by a plunger pump driven from the compressor shaft, replacing a constant flow of city water. The circulation starts when the compressor starts and stops when it is shut down. Tubular automobile radiators keep the water cool.

As a matter of cold fact, pending patent applications are the only valid excuse for withholding from publication the description of anything new. When there is no element of this kind involved a manufacturer's attempt at secrecy almost always indicates either that he is pitifully small-minded and conceited or that he is afraid to submit his designs to the critical consideration of the engineering public.—Power and the Engineer.

MODERN SAFE & VAULT PLANT.

The Dominion Safe & Vault Co. have located at Farnham, P. Q., where they will manufacture the Herring-Hall Marvin safes and vaults. This is a branch of the Herring-Hall Marvin Safe Co., Hamilton, Ohio, a company established 75 years ago.

It was originally intended to erect a plant especially adapted to the manufacture of safes, but the company finally decided to take over the C. P. R. shops at Farnham, Que. These shops formerly employed 450 men. Owing, however, to the desire of the railroad company to centralize their various repair shops in one large shop at Montreal, the Farnham shops were no longer necessary, and they were vacated accordingly.

The plant is equipped with complete power plant. There is a 150 H. P. Corliss engine, a small engine and generator

issue of \$100,000 to accomplish this. It will take about one year for them to be in a position to deliver power.

The accompanying illustrations show layout of the plant, which will be given over to the manufacture of fireproof safes and vault doors, burglar proof safes and vault linings, and such other goods as can be manufactured in conjunction therewith. The designs and styles will be those of the Herring-Hall Marvin Safe Co., of Hamilton, Ohio.

The arrangement of the building is especially suited to the needs of the Safe Co., and will take care of a considerably larger output than is at present contemplated.

The shops are all well lighted, and everything is provided necessary for the comfort of the men. The machine shop is 200 feet long by 66 feet wide, and in this shop the various angles, plates and castings entering into the construc-



Plant of Dominion Safe and Vault Co., Farnham.

for lighting, air compressor, line shafts, heating apparatus, air lines and fire protective apparatus. The C. P. R. tracks pass through all of the buildings, and the Central Vermont touches the property line on the south side, and will put in a siding free of expense, giving direct connections with the two largest railroad systems in Canada—the Central Vermont being a subsidiary company to the Grand Trunk.

A contract has been entered into with Farnham, whereby they agree to give exemption from taxation, with the exception of school taxes, free water, and electrical power delivered on the secondary side of the transformers at \$20 per H. P. per year for 24 hour power, with a minimum of 75 H. P., and with a maximum of 400 H. P. In order to do this it will be necessary for them to develop the water power on the Yamaska River, and they have authorized a bond

tion of the safes, will be machined. The blacksmith shop is a building 105 feet long by 65 feet wide, containing all the necessary forges and furnaces, and here will be made the solid hand welded angle hoops which are a feature of the Dominion Safe & Vault Co.'s Safe. The forging and welding of the various parts of vault linings and burglar proof safes will also be taken care of in this shop. The paint shop is an exceptionally fine building, with sky lights and large windows, and here the final work of finishing the safes will be done. The erecting and fitting of the interior of safe cabinets will be done in the mill, 115 by 64. Directly in the rear of this shop is the dry kiln and lumber sheds, where the oak and other lumber used will be prepared and stored. The lock dept., where the most skilled labor is required, is situated in rear of the office. Combination safety deposit box locks and the num-

erous other locks required in the manufacture of safes and vault doors, will be made and fitted here.

A contract has been entered into with the Canadian Fairbanks Co., Limited, of Montreal, St. John, N.B., Toronto, Winnipeg, Saskatoon, Calgary and Vancouver, whereby they will sell the entire output of the factory.

Following is a statement of the organization of the company:

Incorporated under Dominion charter, February 21st, 1910., capital \$525,000.00. President, Henry J. Fuller; vice-presid-

In general machine shop work the carborundum file assists in quick production, consistent with good workmanship. It is made in a convenient size and shape, and of just the proper grit to be efficient in all around work. The Carborundum File is manufactured by The Carborundum Co., Niagara Falls, N. Y.

TRAVELLING MACHINE SHOP.

The value of a travelling machine shop in the railroad service can hardly be es-

engine is also connected through a friction clutch and chain gear to the wheels, which enables the car to move under its own power at about 12 miles per hour.

NEW USES FOR BOLT HEADER.

The uses to which the bolt header can be put, are varied, judging from the articles produced on this machine, which in many cases is revolutionizing forg-

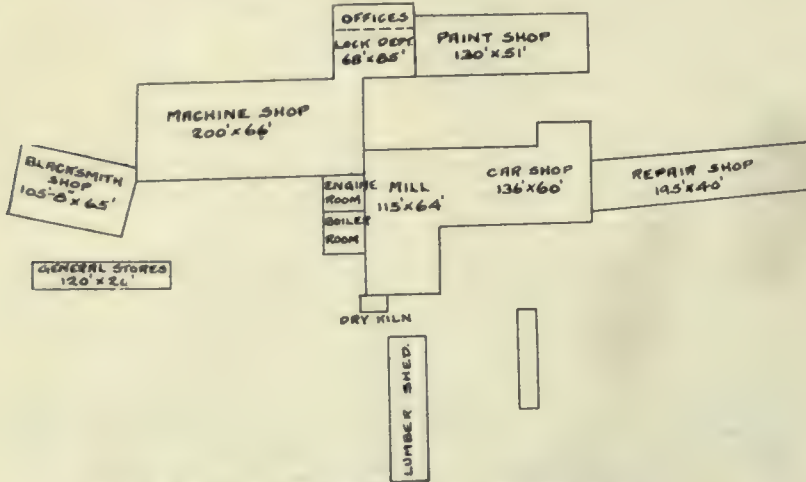

Plant of Dominion Safe and Vault Co., Farnham, P. Q.

ent, A. W. Wheatley; sec-treas., C. W. Baker, C.A.; Works Manager, M. H. Pursell. Directors: Wm. McMaster, C. W. Colby, F. W. Gilman, Thornton Davidson, C. U. Carpenter, A. W. Wheatley, H. J. Fuller

CARBORUNDUM FILE.

The Carborundum file is a solid block of carborundum, 13 inches long, 1 1/2 inches wide, and 1 1/2 inches thick. One end is rounded, and the other fitted with a durable wooden handle. For filing castings, or soft metals, it does the work very quickly; for touching up case hard-



Carbonundum File.

timated. Several of them have been made use of in connection with construction work on the G.T.P. railway. Ordinarily box cars are used, equipped with lathe, drill, grindstone and sometimes a shaper. The power is furnished by 6 h.p. Fairbanks' gasoline engines, belted to a line shaft.

The advantage of having these cars in making light repairs is readily seen. Were it not possible to make repairs in this manner, hundreds of miles would have to be travelled at times to keep the construction equipment and locomotives in repair.

ened parts and removing the scale from the harder metals, it is very efficient. The Carborundum file removes material which would otherwise remain on the casting.

Carborundum is one of the hardest and sharpest of abrasive materials. Every little grit or grain in the carborundum file is as hard, and as sharp as a diamond, and they cut fast, without allowing the file to fill or glaze.

A similar travelling repair shop is used on the North Coast Ry., between Spokane and Seattle, Wash. This is a self propelled car in which the following equipment has been installed: one 23 in. engine lathe, one 16 in. shaper, one 1 1/2 in. bolt cutter, one 6 in. pipe threading machine, one 22 in. vertical drill press, and one emery wheel.

The tools are driven by a 12 h.p. Fairbanks-Morse gasoline engine. The



Fig. 1.—Valve Rocker for Small Pumps.

ing work. Two applications of the machine to articles previously made in a different manner, recently came under the writer's notice and are worthy of note. The new bolt header forging takes the place of a casting in one case, and of a drop-forging in the other. Both instances were observed at the Canada Foundry Co., Toronto, the idea of doing the work in this manner being due to Mr. Loach, general foreman of the machine shop.

Fig. 1 shows a valve rocker arm for a small feed pump, which was previously made of cast iron, but great difficulty was experienced in obtaining castings of this size free from sand holes, with the result that they frequently failed at the shoulder of the crank arm and shaft. As feedpumpbuilding is one of the C. F. Co.'s specialties, large quantities of the rockers are required, so the idea occurred of making dies for the bolt heading machine and making them of wrought iron, which was tried and adapted. An exactly similar method to that followed in bolt heading is used. The red hot stock is first cut off the correct length by the movable cross die, which ear-

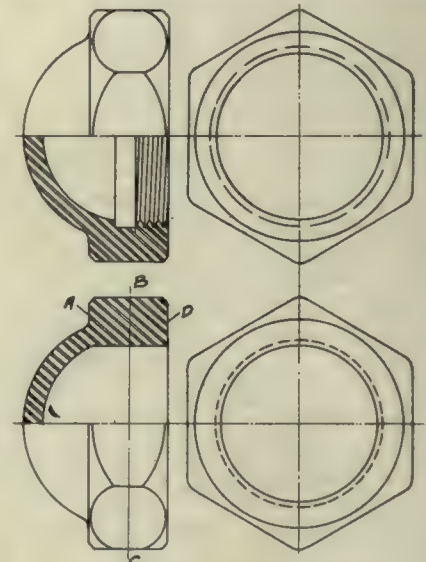

Fig. 2.—Flexible Staybolt Nuts.

ries this stock over against the stationary die. The next move is from the lengthwise die, on the end of which is a die the shape of the rocker end, and which compresses the hot stock to fill the corresponding cavity in the stationary and moving crosswise dies. The operation leaves a very slight flash along the edge A, but other than that no finishing of the non-rubbing parts is necessary, so perfect is the resulting work. Upwards of 2,000 can be turned out in a ten-hour day.

The flexible stay bolt nut shown in Fig. 2, is another piece of work slightly more complicated than the rocker, which is made in the bolt header. The upper figure shows the nut finished and the lower as it comes from the header. Formerly, as before mentioned, these were made by drop forging, which left a rough line about half way up the hexagon, where the flash is trimmed, so the hexagon surfaces were not flat.

Several special dies are required for this operation in the header. First, a flat red hot bar, which passes from side to side through the machine, has a hexagon blank punched out by a die, hollowed out to conform in shape with the rounded top of the nut. This die, bearing against the flat blank, bears only on the outer rim A, and shoves the blank up against the outer of a double die, this latter die being hexagon, of the same cross section as the finished nuts through BC. Thus the lower side of the nut bears against the annular face D. The first die bearing on A and holding the blank up against D, remains stationary, while the inner of the double die which has a rounded end, shoves the metal into the cupped end of the first die, forming the hollow of the nut. The nut is then completed, the operation being repeated for the second nut. Upwards of 3,000 can be manufactured per day by this method, and so successfully has it been in operation, that the Flannery Nut Co., a firm in the United States, specializing in this line, are making over all their machinery to make the nuts this way instead of by drop forging.

STOCKBRIDGE 16 INCH SHAPER.

The 16 inch back geared Stockbridge patented two-piece crank shaper shown is for tool work and productive shop work. This shaper contains some new features designed to add materially to its productive capacity.

Among these is the column ways on which the cross rail slides. The method of attaching cross rail to column is new to shaper practice, though long employed in milling machine design.

With this construction one gib is cast solid with the cross rail, besides adding to stiffness, it prevents possibility of rail tipping away from the column when the adjusting gib, which is on the working side of shaper, is loosened. With this construction no time is lost in going around machine to tighten and loosen binder bolts, everytime the cross rail is lowered or raised. By simply tightening gib binder screws, on working side of shaper, cross rail is locked to column, the construction being just the same as on a milling machine.

The rocker arm is of special design. Slide ribs are cored U-shape making an exceptionally strong construction. The slot in the rocker arm is of unusual depth and width to provide ample surface for crank block.

From the dimensions given it will be noted that this machine is particularly heavy and of unusual capacity for a 16 inch machine. It has been designed to meet all the requirements of a manufacturing tool, requiring strength and accuracy.

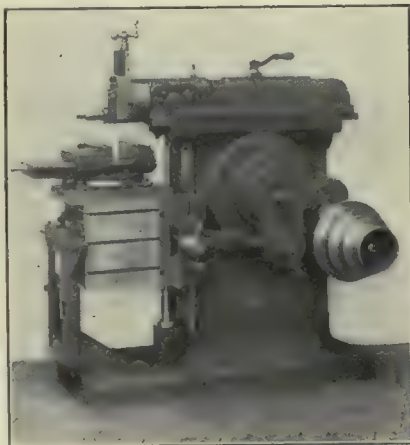

Stockbridge 16-in. Shaper.

Actual length of stroke, $16\frac{1}{2}$ inches. Vertical travel of table, $14\frac{3}{4}$ inches. Horizontal travel of table, 23 inches. Minimum distance of ram to table, $2\frac{1}{2}$ inches. Maximum distance from ram to table, 17 inches. Feed to head, $6\frac{1}{2}$ inches. Top of table, $14\frac{3}{4}$ inches x $13\frac{1}{2}$ inches. Sides of table, $14\frac{3}{4}$ inches x $13\frac{3}{4}$ inches. Ram bearing in table, 30 inches. Length of ram in column, 36 inches. Width of ram in column, $10\frac{1}{4}$ inches. Poppit takes tool, $\frac{5}{8}$ inch x $1\frac{1}{4}$ inches. Takes shaft for keyseating, $2\frac{1}{4}$ inches. Vise opens, 12 inches. Size of Vise jaws, 12 inches x $2\frac{1}{2}$ inches. Tight and loose pulleys on countershaft, 14 inches x $3\frac{1}{2}$ inches. Speed of countershaft for cast iron, 300 revolutions. Fin. Wt. of machine, 2,850 lbs.

These shapers are manufactured by the Stockbridge Machine Co., Worcester, Mass.

FACTORY FIRES.

The Witness, of Montreal, recently published suggestions on fighting fires in large structures, which is of excellent value. It suggests the designing of a card outlining the buildings, each building to have such a card located in a known place for the benefit of the firemen. This card would show at a glance the location of trap doors, elevator shafts, stairways, heavy materials, valuable stock, dangerous or explosive stock, safes or vaults, gas cocks, electric switches, engine or power plants, and all other information needed in fighting a fire in the building. It would enable the salvage corps to do quick and intelligent work, and would enable the fire fighters to direct their efforts more intelligently, without having to search for the information—a difficult thing to do with a structure full of stifling smoke.

The card should be revised whenever there was a change in the position of the stock or fixtures, and in any event should be corrected twice a year. Several copies of the card should be provided, one to be left at some place in the building, one to the department of building inspection and one to the factory inspector, in cases of factories. Variations of the plan could be worked out to fit different structures, but the plan has the nucleus of a valuable suggestion.

UTILIZATION OF SCRAP.

There is in Cleveland a concern that makes a business of blanking metal for other firms that do stamping. Now anybody who knows anything about the stamping business knows that there are hundreds of jobs a year which leave scrap from which many other stampings could be made—if the firm happened to get the order for the smaller pieces. But it may not get such an order for months and to store the scrap from the first job until the second comes, would cost more than buying new sheets for the second. But suppose somebody could make a business that did nothing but blank, suppose somebody could go to a lot of other stamping concerns and get their blanking work? The variety of pieces for which many concerns had orders would be such that the blanking concern could often use scrap twice or three times. The Cleveland man who started the blanking business got the idea by simply asking himself, "Why cannot better use be made of scrap steel than selling for scrap?"—Silent Partner.

The great thing is to make a start, even if you start on the wrong road.

Progress is doing a little better today than we did yesterday.

INDUSTRIAL ^A_N^D CONSTRUCTION NEWS

Establishment or Enlargement of Factories, Mills, Power Plants, Etc.; Construction of Railways, Bridges, Etc.; Municipal Undertakings; Mining News.

Foundry and Machine Shop.

COLLINGWOOD, ONT.—An agreement satisfactory to the Board of Trade has been submitted by representatives of the New Iron & Steel Co. which proposes to establish works for the manufacture of wrought iron directly from the ore by a new process. The agreement must next be adopted by the town council and after that ratified and financially provided for by the rate-payers.

BRANTFORD.—Brantford city council has granted fixed assessments for a term of ten years to the Ham and Nott, Crown Electric, and Brantford Emery Wheel Co.

OTTAWA.—The Ottawa Car Co. secured permit for factory, Albert Street, \$10,000.

PARRY SOUND.—The C.N.R. will establish a repair plant and shops at Parry Sound.

AMHERST, N.S.—The carriage factory of S. Fillmore, Southampton, 20 miles from here, was destroyed by fire on the 11th inst. Estimated loss \$35,000.

OTTAWA.—Publicity Commissioner, H. W. Baker, announces that three industries are about to locate in Ottawa. There will be an automobile factory, a structural steel works, and a factory for the manufacture of fibre boards out of sawmill waste.

OSHAWA.—Steam Fittings, Ltd., have under construction a new shipping room 180 x 250 ft. The old shipping room will be used as a tapping room.

LONDON.—Geo. White & Sons are equipping their new shops complete with Chapman double ball bearings.

TORONTO.—The Chapman Double Ball Bearing Co. have secured an order for 369 of 2 15-16 inch. double ball bearings for the N.T.R. shops at Transcona near Winnipeg. The shipment is to be made in December.

MONTREAL.—A report has been current in one or two trade newspapers that Geo. Anderson & Co., manufacturers of stone cutting machinery, Carnoustie, Scotland, are about to erect a factory in Montreal. Mr. Clark, their Canadian manager, speaking to Canadian Machinery stated that the rumor was news to him. The firm already have a small plant there and it is true are contemplating the erection of a larger factory in Canada, but Mr. Clark states that they will undoubtedly locate in some more Western point such as Winnipeg or Port Arthur.

WELLAND.—The Canadian-Billings & Spencer Co. intend enlarging their machine shop at an early date.

WINDSOR.—The Penberthy Injector Co., Detroit, is preparing to build a large addition to its Windsor plant.

MONTREAL.—It has been stated to Canadian Machinery by a reputable manufacturer, of Montreal, that there is a good opening in that city for a manufacturer of dies for punching brass, metal, etc. He claims that a lot of this business goes over to die manufacturers in the United States from machinists who have not the facilities for making satisfactory dies for their own use.

HAMILTON.—A deal for the merging of the Baynes Carriage Co., this city, the American Road Machines Co., of Canada, located at Goderich, and a group of Detroit automobile men was completed recently. The merger will be known as the Acme Motor, Carriage and Machinery Co., capitalized at \$1,000,000. The chief business of the company will be to manufacture autos and the present site of the Baynes Carriage Co. is to be utilized for the erection of a large factory. It is understood that the plant at Goderich will be abandoned.

PETERBORO.—The Peterboro Lock Mfg. Co. has been granted a fixed assessment of \$25,000 for ten years. The company is spending \$40,000 in improvements, and 40 additional employes have been added this year.

SYDNEY, N.S.—The Dominion Iron & Steel Corporation are calling for tenders for the construction of the following additions to their plant:—Boiler house, machine shops, foundry, warehouse, oil house, carpenter shop, repair shop and finishing mill. Cement, brick and structural steel are the materials to be used.

WINNIPEG.—The Canada Metal Co. will establish a plant in this city. They have purchased the present premises of the Ontario Wind Engine & Pump Co. for \$26,000. The latter Co. will erect a new building.

VICTORIA, B.C.—Commencing Nov. 7th examinations for the position of inspector of steam boilers and machinery will be held at the parliament buildings this city.

SASKATOON.—The J. I. Case Co., of Racine, Wis., will build a large warehouse in Saskatoon this fall.

WINNIPEG.—The Otis-Fensom Elevator Co. proposes to erect a machine shop in Winnipeg for manufacturing and adjusting elevator parts.

HAMILTON.—The Dowsell Co., Hamilton, which manufactures wringers, washing machines and kindred articles, has changed its name to the Cummer-Dowsell Co. and increased its capital stock from \$75,000 to \$250,000. Extensions of its plant are projected.

DUNDAS, ONT.—The Chapman Engine & Mfg. Co. has received incorporation under Ontario laws, the capital stock being \$200,000, and the head office being at Dundas, Ont. It will manufacture engines and machinery.

TROUT MILLS, ONT.—The reduction and smelting works at Trout Mills, Ont., which have been closed down of late, are shortly to become active under new auspices.

TORONTO.—The Toronto yards of the Canadian Shipbuilding Co. have been taken over by the John Inglis Co., which will make use of them in connection with its machine and engine works in their vicinity.

TORONTO.—The Steel & Radiation Co., of Canada, with a capital stock of \$5,000,000, is announced as the latest Canadian merger in the steel and iron group. Two Toronto companies are named—the King Radiator Co. and the Expanded Metal & Fireproofing Co.—among those to be embraced. The works of these two concerns, in which nearly 300 men are employed, will be enlarged.

MONTREAL.—The Quebec government will give a grant of \$15,000 towards the construction of an iron bridge over the Chaudiere river to cost \$33,000.

MEDICINE HAT, ALTA.—The McDermid Co., contractors, of Winnipeg, have erected a new machine shop adjoining the C.P.R. roundhouse. The building, which is 82 ft. x 70 ft., is of brick on a concrete foundation and will be equipped with the most up-to-date machinery.

MEDICINE HAT.—E. C. Darche and W. R. Penland are conducting the garage and repair shop formerly owned by G. M. Johnson. Besides the automobile livery and repair shop they will be agents for the leading cars, featuring the McLaughlin-Bulck, E.M.F., and Winton makes.

WINNIPEG.—Sealed tenders have been asked for by the Transcontinental Railway Commissioners at Ottawa, for the centrifugal pump and motors required for the sewage pump house at the Winnipeg shops.

WINNIPEG.—The roof, most of the machinery and a considerable part of the building of the Western Iron Works were damaged by fire recently.

LONDON.—The name of the Scott Machine Co. has been changed to the London Gas Power Co.

TORONTO.—Edward Gurney, president of the Gurney Foundry Co., Toronto, tendered a complimentary dinner to W. H. Carrick, president and general manager of the Hamilton Stove & Heater Co., Hamilton, at the National Club, Toronto, on Friday, Oct. 7, in appreciation of his 38 years' service with the Gurney Foundry Co.

LAKE SUPERIOR JUNCTION, ONT.—Sealed tenders have been asked for by the Transcontinental Railway Commissioners at Ottawa, for machinery required for a roundhouse at Lake Superior Junction.

REGINA.—The Burrige Cooper Co., of Winnipeg, dealers in gasoline engines, pulleys, shafting and machinery of all kinds, will open a Saskatchewan agency in Regina where they have purchased warehouses.

HALIFAX.—The Silliker Car Works have been sold to a group of financial men in Halifax, Amherst and St. John, headed by J. R. Douglas and J. R. Lamy. The industry will be carried on as formerly with the addition of a steel underframe department.

GUELPH.—The Loudon Machinery Co. were awarded the gold medal at St. John, N.B., for the best exhibit of farm hardware.

WOODSTOCK.—The Tobin Arms Mfg. Co. has purchased the plant, patents, tools, materials, manufactured products and other assets of the Caldwell Bit and Tool Co., Port Rowan, Ont. Extensions are being made by the Tobin Co. in their present factory to accommodate the new plant.

MONTREAL.—Nathaniel Curry, president of the Canada Car and Foundry Co., has been elected to the directorate of the Travelers' Life Assurance Co., of Canada. Mr. Curry is also a director of the Bank of Nova Scotia.

Electrical Notes.

QUEBEC.—The Shawinigan Water & Power Co., at Shawinigan Falls, on the St. Maurice River, Quebec, is about to increase its power producing capacity by 75,000 h.p. This involves the cutting of a section out of the side of the intake canal 1,000 ft. long, and the erecting of a concrete and steel bulkhead at an angle of 60 degrees to the existing bulkhead. From this extension five steel penstocks, each having a capacity of 15,000 h.p., will be carried to the power house to be erected on the lower level, to which there will be a head of 150 ft. The power house is to contain five units, consisting of turbine water wheels directly connected to an electrical generator.

TORONTO.—Tenders are invited for the purchase of the plant, raw material, real estate, etc., of the Reeder Electrical & Mfg. Co., 15 Saunderson Avenue.

LONDON.—Mackenzie & Mann are stated, on good authority, to be taking steps for the acquiring of the London Street Ry., and also the London & Lake Erie Traction Co.

QUESNET, B.C.—Local interests are agitating for an electric light system and power plant.

WINNIPEG.—Plans are being prepared for the central power sub-station. The building will cost about \$60,000 and the work will be let this fall. It is to be completed by June 1911.

MONTREAL.—The acceptance of a 10-year contract with the Montreal Light, Heat & Power Co. for street lighting has been recommended to the city council.

BENCH POWER PRESS

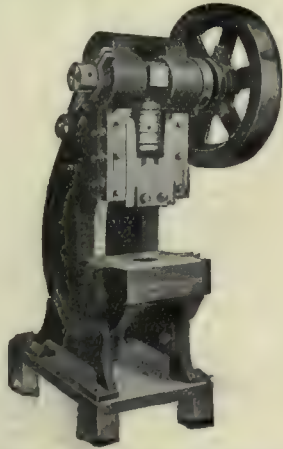

New Design

Particularly adapted for small, quick work, to take place of foot presses.

Write for Prices.

W. H. Banfield & Sons

MACHINISTS, DIE AND TOOL MAKERS
120 Adelaide Street West
TORONTO - - - CANADA

"GLOBE" TIME RECORDERS



are made in Canada by expert mechanics. They are accurate, simple in construction, strong, and of good chaste appearance. They will record with absolute accuracy the arrival and departure of your employees (TO THE MINUTE), making you pay for what you get and no more. All late and short time marked in red, regular time in green. The small cut at the top illustrates the WEEKLY MODEL, an entirely automatic recorder requiring no attention whatever during the week, as all changes, etc., occur automatically (DONE BY CLOCK WORK). The DAILY MODEL is shown in the cut at the bottom. This recorder is being used mostly in large shops, etc., where a large number of hands are employed. With the "GLOBE" TIME RECORDERS only one operation is required as against five with most others.

Inspection may be made through the glass sides of the case, but tampering with records is impossible, no danger of having soiled, torn or lost records when same are unfavorable, as is the case with all CARD CLOCKS. We are now manufacturing over 224 DIFFERENT TIME RECORDING CLOCKS, and are in a position to meet the requirements of any business. Write us about your needs and let us suggest what will best meet with your requirements. WE SOLICIT YOUR ENQUIRY.

W. A. WOOD, Manufacturer

Head Office and Factory: 40 St. George St., Montreal

Branch Offices:
19 Bleury St., Montreal 65-67 Victoria St., Toronto



Barr Combined Drilling and Tapping Machines Do Save Money

It would pay you to sell your separate drilling and tapping machines and get a Barr Combined Machine that will do the work of both better and quicker.

A Barr Combined Drilling and Tapping Machine saves time, labor and floor space

No. 51 weighs 550 pounds, drills up to 3/4-inch holes and taps up to 1/2-inch holes in cast iron.

No. 11 weighs 275 pounds, drills up to 9-16 inch holes, and taps up to 7-16 inch holes in cast iron.

We can give you power feed, lever feed, and tappers in any combination to suit your requirements on machines having from two to six and seven spindles.

AGENT WANTED

FOR WESTERN CANADA

An Energetic Selling Agent can make good money selling Barr Machines in the Western Ontario and Western Canada Territory. Hundreds of shops should be using these machines and will use them when shown their absolute supremacy.

Write me for full particulars.

H. G. BARR

Worcester, Mass., U.S.A.

Williams & Wilson, Montreal
Agents for Eastern Canada

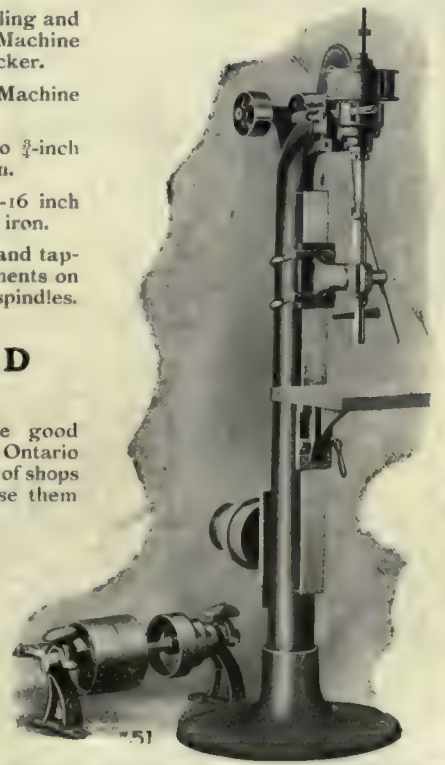

Don't fail to mention "Canadian Machinery" in writing to advertisers.

Special Taps Special Dies Special Reamers

Unless you have special appliances, you can get these tools from us better and cheaper than you can make them.

We have the equipment and the experience. Ask us for prices.

A. B. JARDINE & CO.
HESPELER, ONT.

STEELCRETE EXPANDED METAL

REINFORCEMENT for CONCRETE FLOORS
and ROOFS.

The most reliable bond for all varieties
of concrete slab.

WRITE FOR HAND BOOK AND SAMPLES

Competent Engineering staff in charge
of construction.

Expanded Metal & Fireproofing Co., Limited
100 King Street West. TORONTO

MAPLE LEAF
STITCHED COTTON DUCK
BELTING
DOMINION BELTING CO. LTD.
HAMILTON CANADA

MONTREAL.—The proposed merger of the Montreal Light, Heat & Power Co. and the street railway system is expected to effect economies in management and a concentration of interest which will be beneficial to the general public.

DUNSMUIR, B.C.—The Canadian Collieries is making preliminary surveys near Comox, B.C., for a large hydro-electric plant on the Puntledge river. It is estimated that 50,000 horsepower can be developed, which will be used to furnish power for a system of compressed air haulage in the mines for operating machinery in various plants and for operating a 14-mile railroad connecting the Comox coal fields with Union bay.

PRINCE ALBERT.—C. H. Mitchell, Toronto, has been authorized by the town to prepare plans for city power developments at Lacelle Falls. It is planned to develop 10,000 horsepower at a cost of \$1,000,000.

TORONTO.—The tenders of Chapman & Walker Co., storage batteries, \$2,870; Canadian General Electric Co., transformers, \$15,800; Lancashire Dynamo & Motor Co., motor generator sets, \$2,262, were accepted by the Board of Control for the Hydro Electric department.

KINGSTON.—The Seymour Power Co. offer to supply Kingston with electric energy at \$25 per horse power.

GALT.—The municipality has asked for tenders for debentures to cover the cost of a plant to distribute Hydro-Electric power in the town; the cost is \$66,000.

BROCKVILLE.—Construction work for power plants on the American side of the St. Lawrence river is to be commenced and it is expected the Canadian government will investigate to ascertain if the flow and levels of the river on the Canadian side will be materially affected.

CHESTERVILLE, ONT.—A by-law has been passed providing for the establishment of an electric light system.

JOHN J. GARTSHORE

83 Front St. W., Toronto

RAILS and SUPPLIES

New and Second-hand

For RAILWAYS, TRAMWAYS, Etc.
Old Material Bought and Sold.

OPAL GLASS TILING

FOR WALLS OF

MACHINERY AND POWER HOUSES

Most approved material.

TORONTO PLATE GLASS IMPORTING CO'Y

PLATE AND WINDOW GLASS

135 to 143 Victoria St., - Toronto

Boilers

HORIZONTAL OR VERTICAL, any size and any pressure. Marine Boilers too. Ask for our Catalogue.

Wm. Hamilton Co., Ltd.
PETERBORO, ONT.

Russell Machine Co.
MACHINE TOOL
AND
DIE MAKERS

First-class Workmanship

Prices Right

Estimates Furnished to the Trade

Russell Machine Co.
St. Catharines, Ont.

In making Pipe connections always use

Dart Unions

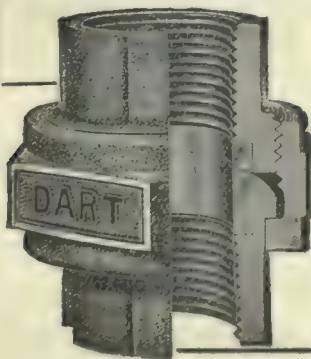

No packing required. As shown in the cut, the two sections of a Dart Union are brought together in the form of a ball joint. Each section is bronze seated. So that Dart Unions make a Bronze-to-Bronze Ball Joint that simply cannot leak. Joints can be made with great speed, even if pipes are out of alignment.

YOUR DEALER SHOULD
SELL THEM. ASK HIM.

Dart Union Co., Limited

93-97 Niagara Street, TORONTO, ONT.

Oil Tempered Steel Springs

—for every purpose
and the best for each
use.

—Special styles of
all kinds to order.

**THE CLEVELAND
WIRE SPRING CO.**

Cleveland, Ohio.

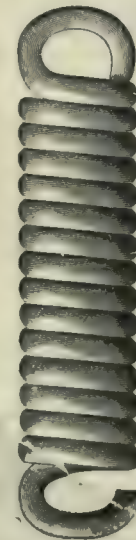

VICTORIA, B.C.—The immense electrical generating plant at Jordan River is being completed by the Vancouver Island Power Co. Of a total expenditure of \$600,000 to date only a small proportion has been for machinery.

COLLINGWOOD.—The material for an up-to-date power house is now at the yards of the Collingwood Shipbuilding Co. The plant throughout is run by electric energy and the new equipment will provide power to thrice the present capacity. A producer gas plant may be installed.

NIAGARA FALLS, ONT.—It is reported that the Symmes Construction Co., of this place, will shortly commence work on a power plant at Sandy Falls, Myosoni river, in the Porcupine district, the plant to develop from 6,000 to 8,000 h.p.

COMOX, B.C.—Surveys are being completed for the big power plant to be erected by the Canadian Collieries on the Puntledge river in the centre of the Comox coal field. About a year will be occupied in completing the work and the cost will be in the neighborhood of \$1,000,000.

VANCOUVER.—Law & Von Dohlen are organizing a company to manufacture the Grey Automatic Electric Water Heater. The capital stock is \$150,000. Other electric utilities will also be manufactured.

WATROUS, SASK.—The municipality proposes to instal an electric lighting system and a car line.

Municipal Undertakings.

MOOSE JAW, SASK.—On Nov. 5th, the city offers for sale by auction at the power house a second hand well-boring plant. Terms cash, subject to a reserve bid.

WINNIPEG.—The hospital committee will submit two by-laws at the civic elections, one for \$400,000 for the General Hospital, and one for \$400,000 for the Municipal Hospital.

MONTMAGNY, QUE.—Tenders will be received until the 1st of December by the municipality for the erection of an iron bridge over the Riviere du Sud.

MONTREAL.—Plans for the new power station at the drop off power are being prepared. This new plant will generate an extra amount of power equal to that now furnished the city, viz., 3,000 h.p.

MONTREAL.—The contract for the new aqueduct intake at Point St. Charles has been awarded by the Board of Control, to Lemoine & Son, and L. A. Desy; the price is \$155,500. The work will be rushed this season.

MONTREAL.—Plans and specifications for the remodelling of the emergency hospital are being prepared, same to include new drainage, plumbing and heating.

PRINCE ALBERT, SASK.—Plans are being prepared and contracts will be let next May for the erection of a 10,000 h.p. plant at Leslie Falls. Cost to be \$1,000,000.

WINNIPEG.—The tender of the Canada Iron Corporation for the supply of 10,000 feet of six-inch water main was accepted by the board of control. The price is \$57.50 per ton, which is much lower than that quoted in the next lowest tender.

PRINCE ALBERT.—The tenders for the filtration-plant were as follows: One at \$14,000, another at \$11,000, and Wm. Knox's tender at \$6,985 (accepted.)

RIGGAR, SASK.—\$15,000 will be expended on waterworks and fire protection.

CALGARY.—Tenders will be received by W. D. Spence, city clerk, up to November 7th, for the erection of steel bridges, one across the Elbow river at 12th Avenue and the other across the Elbow river at Second Street East. Also for supplying to the city rails, cars, equipment and overhead material for extensions to the municipal street railways.

NEW LISKEARD, ONT.—A waterworks extension by-law was carried here last month.

NANAIMO, B.C.—Sewers costing about \$70,000 will be installed by the municipality.

WHITE METAL
PRESSURE DIE
NO MACHINE WORK NECESSARY—WRITE FOR FACTS
LUMEN BEARING CO., TORONTO

BETTER RESULTS AT LOWER COST
can be secured for any class of castings by arranging your mixtures by analysis. Years of practical experience in foundry work are at your service when you consult with
The Toronto Testing Laboratory, Limited
18 SATURDAY NIGHT BUILDING, TORONTO
EXPERT FOUNDRYMEN, METALLURGISTS, CHEMISTS
TESTS OF METALS, FUELS, CORES, OILS, Etc., AT REASONABLE PRICES.

**BEST
LEATHER
BELT
MADE**

TORONTO MONTREAL WINNIPEG
St. JOHN, N.B. VANCOUVER



ESTABLISH A MODERN TAX-FREE ALCOHOL DISTILLERY

We have a Good Proposition for Motor Mfrs.

Having exported our Stills in large amounts for many years, and already having several far Eastern agencies we are now open to establish additional agencies and invite correspondence to that end, looking after our old customers and prospective buyers by special successful demonstrative methods for making Alcohol, Apple Jack, Aguardiente, Mescal, Tegulla, Peach Brandy, Whiskey, etc. Most modern and simple. All sizes, 5 to 500 gallons daily capacity distilling apparatus.

ARE YOU LOOKING FOR information relating to INDUSTRIAL or DENATURED ALCOHOL DISTILLING APPARATUS and the amazing possibilities of the utilization of waste farm products and wood waste by superheated steam distillation, the distilling apparatus as used by us; the principle involved, also the methods of chemical control and disposal of the product and by-products? We will gladly say to you:

Denatured Alcohol to-day is of the greatest untold benefit to the American motor people. It opens an absolutely new field for investment for progressive paper pulp and chemical fibre mills, paint, varnish, soap and candle makers, gardeners, farms and garbage plants, saw-mills, lumbermen and canneries. The Automobiles and the Navies of the world clamor for this new tax-free cheaper industrial alcohol. May we expect some encouragement from the more patriotic pioneers for this new American Industry? The field is new and profitable, and you can practically have the business your own way by starting now. We are makers of an apparatus for the production of this denatured or industrial alcohol; we build and install plants—large or small. The initial cost of a plant is small; the financial risk—if any—is trifling. The equipment is such that it can be added to at any time without disturbing the original installation.

Address
THE WOOD WASTE DISTILLERIES CO., Inc.
WHEELING, W. VA., U.S.A.

MALLEABLE IRON CASTINGS

PRATT & LETCHWORTH CO. BRANTFORD ONTARIO

The British Aluminium Co., Limited LONDON, - ENGLAND

Beg to announce THE OPENING on
October fifteenth, 1910, of their new

Canadian Headquarters, at 24 Adelaide St. W., Toronto

in charge of

MESSRS. PARKE & LEITH, General Agents for Canada

A Large Stock of Aluminium in all the Commercial Forms will
be kept—Wholesale and Retail.

JESSOP'S Best Tool Steel "ARK" High-Speed Steel

THE FAVORITE BRANDS WITH USERS OF GOOD STEEL.
A LARGE ASSORTMENT OF SIZES IN STOCK.
JESSOP'S HIGH-GRADE FILES AND RASPS.

80 Bay St., Toronto, Ontario
Chas. L. Bailey, Agent.

Reid-Newfoundland Company
St. John's, Newfoundland.

WM. JESSOP & SONS, Limited, Manufactory, SHEFFIELD, ENGLAND.

Jas. Robertson Co., Ltd.
Montreal, Quebec

Jas. Robertson Co., Ltd.,
St. John, New Brunswick



Crucibles are part of the expense of your foundry. It will pay you to be sure you're using the best.

Dixon's Crucibles

have a record of 83 years behind them. You will find them adapted to your melting.

Free booklet, 223-A, sent on request

JOSEPH DIXON CRUCIBLE COMPANY
JERSEY CITY, N.J., U.S.A.

GLEICHEN, ALTA.—R. B. Owens, the provincial health officer, has been consulted regarding a new waterworks system.

OAKVILLE, ONT.—By-laws have been passed issuing debentures for \$20,000 with which to extend the present waterworks system.

OTTAWA.—It has been recommended that the city purchase an incinerator plant of the Heenan-Proude type. The estimated cost is \$34,000.

GUELPH.—The money and the franchise by-laws in connection with the People's Railway were carried on Sept. 26th. The contract calls for completion of the entire system by July 1912 when radial connection will be maintained between Guelph, Berlin, Elora, Fergus, Arthur, Hespeler and Puslinch Lake.

BRANDON.—The work of laying the mains for the new steam heating plant at the Electric Light Co.'s central station is completed as prescribed in the contract. Connecting the service to the different buildings is being rushed; there are 65 blocks to connect with the heating plant. Everything has worked perfectly and the system commenced operation last month.

FORT WILLIAM.—Among a large number of public improvements submitted to the vote of the ratepayers on Sept. 21st, the following will be carried out:—Extension of waterworks, improving fire halls and cemetery, erecting a new police station, building a swimming pool and improving the streets. Proposed improvements to the city hall and the giving of a gas franchise were voted down.

PENTICTON, B.C.—Having purchased the irrigation system from the Pentiction Water Supply Co., Pentiction will install a complete domestic water, electric light and power system. The municipal engineer has been requested to prepare a preliminary report upon the cost of installation.

ROLEAU, SASK.—A loan of \$45,000, with which to install a water works system, is being negotiated by the municipality.

NORTH BUXTON, ONT.—The municipality is in the market for a new pump house, a wheel, a boiler and an engine.

DAUPHIN, MAN.—Work has been commenced on the contract for 13 miles of waterworks mains and 13 miles of sewers in this town. The work is to be completed within two years at a cost of \$350,000. J. J. Flanagan, of Fort William, is the contractor.

General Manufacturing News.

HAMILTON.—Charles Reed & Sons, manufacturers of paper boxes on a large scale in Hamilton, Ont., have bought a site in Winnipeg. They will build a warehouse there next year at a proposed cost of \$300,000.

QUEBEC.—It is expected that Dominion Government will have constructed at the Davies dock at Quebec this winter a vessel to be used as a transport between Quebec and Levis in connection with the N.T.R. This is to serve in the interim between the completion of the railroad and the completion of the bridge. The cost is to be between \$300,000 and \$400,000.

KINGSTON.—Coward's Boat Works have been very busy this season, 308 boats having been built there since the beginning of the year. Contracts have just been secured for 20 family launches for a Toronto engine company and for several boats for private parties.

DUNCAN, B.C.—North Cowichan will install an electric plant, the necessary by-law having been carried. The electricity will be generated by steam power.

BERLIN.—Baetz Bros. & Co. have commenced building their new furniture factory. The Wonder Furniture Co. are erecting a large addition to their plant.

THREE RIVERS.—The contract for the pulp mill of the Union Bag & Paper Co., at Cap de la Magdaleine, Three Rivers, P.Q., Canada, has been awarded to Frank B. Gilbreth, No. 60 Broadway, New York. George F. Hardy, No. 309 Broadway, New York, is the engineer.

SIMCOE, ONT.—The Penman Mfg. Company, whose product is knitted goods, proposes to add to its existing Canadian factories one in Simcoe, Ont.

SPECIAL MACHINERY, Etc.

ARMSTRONG BROS.

18 Sheppard St., Toronto
Mfrs. of **SPECIAL MACHINERY**
Patents Perfected
GEAR CUTTING, TOOLS, DIES, ETC.
Ruching and Pleating Machinery.

ERNEST SCOTT

91 BLEURY ST., - MONTREAL
Machinist and Tool-maker
Dies for sheet metal work. Stampings and
light manufacturing. Special machinery
designed and made to order.

The PARMENTER BULLOCH CO., Ltd.
GANANOQUE, ONT.

Iron and Copper Rivets, Iron and Copper Burrs
Bifurcated and Tubular Rivets, Wire Nails,
Copper and Steel Boat and Canoe Nails,
Cacutcheon Pins, Leather Shoe and Overshoe
Buckles, Fellos Plates.

OWEN SOUND IRON WORKS, LIMITED
OWEN SOUND, ONT.

Cement Mill Machinery, Boiler and Steel
Tank Work of all kinds, Grey
Iron and Brass Castings

PATTERNS AND MODELS

**PATTERNS
IN WOOD**

~ ALL KINDS ~

Difficult Core Work a Specialty
High Grade - Right Prices - Prompt Delivery
SATISFACTORY WORK GUARANTEED

THE HAMILTON PATTERN WORKS
258 CATHERINE STREET NORTH
HAMILTON, ONT.

PATTERNS

FOR
ALL KINDS OF MACHINE
WORK MADE IN
WOOD, BRASS
WHITE METAL OR IRON

by the very highest class of skilled
mechanics.

Only the highest grade of material
used in our work. We can handle
your pattern work to your complete
satisfaction.

Let us quote prices.

TORONTO PATTERN WORKS
87 Jarvis St. Toronto, Canada

When writing advertisers kindly men-
tion having seen the advertisement in
this paper.

LONDON.—J. K. and D. H. McDerimid, of this
city, have purchased the plant of the C. R.
Somerville Paper Box Co.

BRANTFORD.—The Ham & Nott Co., of this
city, will take over the Niagara Bedstead Co.,
of Buffalo, and locate it in the new building to
be erected near their present factory.

FORT WILLIAM.—The Seaman-Kent Co., ma-
nufacturers of hardwood flooring and finishings,
commenced operations in their new plant here
on Sept. 23rd.

GODERICH, ONT.—The building, plant and
stock of the Goderich Organ Co. was destroyed
by fire. Estimated loss, \$100,000. Local manager,
A. Saunders. It is stated the mill will be re-
built at once.

NANAIMO, B.C.—The Red Cliff Brick and Tile
Co. has been incorporated for the purpose of
erecting a brick-making plant with a capacity
of 40,000 daily.

EASTERN ONTARIO.—The Hawthorne Silver
& Iron Mines, an American company, will de-
velop the iron ore deposits in the counties of
Lanark and Frontenac.

CHICOUTIMI, P.Q.—The Canada Paper and
Pulp Co., recently granted a federal charter,
propose establishing a giant plant for the ma-
nufacture of a paper, pulp and carbide on the
Saguenay river, near Lake St. John. The op-
portunities for obtaining water power at that
point are held to be excellent.

NELSON, B.C.—The establishment of a zinc
smelter is being considered. A representative of
French's Complex Ore Reduction Co. was here
and formed a favorable opinion of the location.

SYDNEY.—Following a conference with the
president and secretary of the Dominion Tar and
Chemical Co., manager Walsh announced that
new machinery will be installed to handle the
increased output. The present force of fifty men
will be augmented fifty per cent.

ST. JOHN, N.B.—The Wilson Box Co. have
converted the plant of the Dunn Pork Packing
Co., which they purchased, into a box factory
and will employ fifty men. The Box Co. have
also bought the Crawford sawmill at Westfield
and will operate it in connection with their St.
John factory. The officials of this new com-
pany are—T. H. Estabrooks, Pres.; Stanley
E. Elkin, vice-pres.; W. I. Fenton and John
Galey, directors; Alex. Wilson, managing direc-
tor.

PORT ARTHUR.—The Port Arthur Wagon Co.,
a new concern, has taken over the Speight
Wagon Co., of Markham, which will, when the
new factory is erected at Port Arthur, be re-
moved there.

Planing Mill News.

VICTORIA, B.C.—Iowa people who hold a tim-
ber tract at the mouth of the Skeena river may
build a mill. To report on the situation, A. C.
Voss, of Cedar Rapids, made a trip recently to
look over the ground.

EVANS CREEK, B.C.—Mr. G. C. Poulin, of
St. Johns, Que., is opening the lumber mill at
Evans Creek, B.C.

ESPRIT, QUE.—Guertin & Fils, saw mill pro-
prietors, Grand St., Esprit, Que., are reported
to have assigned.

PARRSBORO, N.S.—O. J. O'Brien, lumber
manufacturer, of Noel, N.S., has sold his sta-
tionary mill and about 1,200 acres of timber
lands at Noel, to McDonald Bros., of Parrsboro.

ORFORD, QUE.—Fire at the Dougherty Mill,
Orford, Que., recently resulted in the total de-
struction of the mill, which was owned by the
Fletcher Lumber Co. The loss will be over \$10,-
000.

STRATHROY, ONT.—The Strathroy Furniture
Co. are erecting a drying kiln. The new build-
ing will have a capacity for drying 500,000 feet
of lumber.

NORTH BAY.—The council received a commu-
nication from J. Darrell, chairman of the Indus-
trial Committee of the Board of Trade, asking
the council to take action in regard to the pro-
position of D. A. Leach, of Sunbridge, who of-

ONE MAN
can cut threads on 6-in. pipe with a
“BEAVER”
ADJUSTABLE DIE STOCK



No. 6, threading 1-4, 3-8, 1-2, 3-4 in. complete.
No changing of Dies or Bushings.



No. 25B, 1 in. to 2 in., R.H. complete.

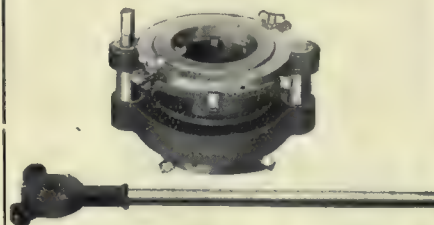

No. 60, cuts 2 1/2, 3, 3 1/2, 4, 4 1/2, 5, and 6 inch pipe

NOTE—That with the three tools
shown above you can thread from
1-4 in. to 6 in. pipe. No loose parts.

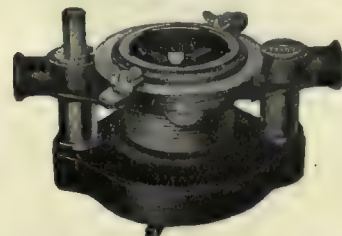

No. 41, cuts 2 1/2, 3, 3 1/2 and 4 in. pipe.



“WARREN” DIE STOCK

(Non-receding dies - adjustable.)

Each stock cuts two sizes. Made in four sizes.

Prices \$5.00, \$5.50, \$6.00 and \$7.00.

THEY SAVE TIME AND MONEY
Write for our Illustrated List

Borden-Canadian Co.
Richmond St. East, Toronto, Ont.

WANTED

The Services of a Representative in Canada

to look after our old customers and prospective buyers of our Modern, Simple, Tax-free Industrial Alcohol Distilling Apparatus, by special successful demonstrative methods for making Alcohol, Apple Jack, Aguardiente, Mescal, Tequila, Peach Brandy, Whiskey, Solidified Alcohol in Cubes, Etc., also Denatured Alcohol. Most modern, simple, 5 Gal. Still and all sizes to 500 Gal. Daily Capacities. Good Salary and Commission. Address with three references.

THE WOOD WASTE DISTILLERIES CO., Inc.
Wheeling, W. Va., U.S.A.

Do Your Tumbling

In a Globe improved Tilting Tumbler and get finest results quickest and cheapest. It is made in six sizes for all purposes for wet or dry work.



"GLOBE"

Dies Stampings.
Special Manufacturing Contract Work.

If you want to get an interesting little magazine free, ask for "THE SILVER ENT PARTNER."

THE GLOBE MACHINE & STAMPING CO.

899 Hamilton Street, Cleveland, O.

Canadian Agent:

H. W. PETRIE, Front St. W., Toronto, Canada

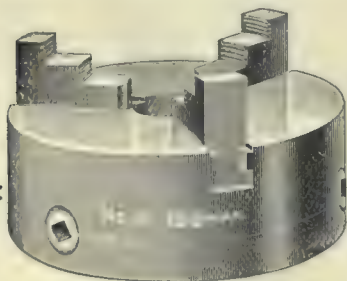

"CUSHMAN" CHUCKS

For general machinists' use. Strong and durable and designed for hard service.

Our catalogue shows many styles and sizes and is sent free.

The Cushman Chuck Co.

Hartford, Conn., U.S.A.

Established 1882

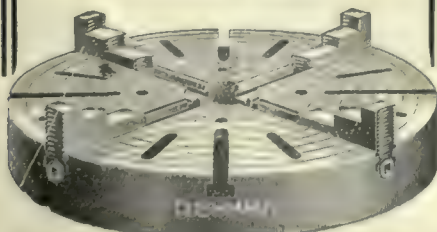

ers to establish veneer plant, basket factory, sawmill, stove and hoop mill. Estimated cost, about \$25,000.

NEEPAWA, MAN.—A match factory is to be erected here, to employ 25 hands. Construction will begin at once. Business men of Neepawa have subscribed \$40,000 of the capital. The names of the promoters have not yet been made public.

SOLDEN, B.C.—The wreckage of the Columbia River Lumber Company's mill at Golden, B.C., which was destroyed by fire in July last, has been cleared away and rebuilding commenced. It is expected that the new mill—which is to be second to none in the mountain country—will be ready to commence cutting when the season opens next spring.

CLAYBURN, B.C.—The Maple Grove Lumber Company's saw mill near Clayburn, B.C., has been destroyed by fire, the plant being a total loss. The loss will be about \$10,000, with very little insurance. The capacity of the mill was about 10,000 feet.

PRINCE ALBERT.—The Shell River Lumber Co. is building a mill at the west end of Prince Albert, Sask. It will have a capacity of between 30,000 and 40,000 ft. per day.

NEW WESTMINSTER, B.C.—The Lincoln Sawmill Co., of Langley Prairie, has secured one of the largest lumber cutting contracts ever given

out in the province. It has undertaken to cut and dress 30,000,000 feet of lumber for Michigan capitalists, owners of valuable timber land.

ROCHE POINT, B.C.—The Imperial Car, Shipbuilding and Drydock Co. will erect and operate a sawmill here with a capacity of 100,000 feet per day.

CANFORD, B.C.—A sawmill with a daily capacity of 40,000 feet, and modern machinery is to be erected here; estimated cost \$25,000.

VICTORIA, B.C.—D. E. Smith, manager Jordan River Lumber Co., has announced the intention of the company to erect a sawmill in the early spring. A site has not yet been chosen.

NEW LISKEARD, ONT.—C. B. Matthews will build a mill. Recently a by-law to grant Mr. Matthews assistance was defeated.

MASSET, B.C.—Negotiations for the erection of a mill here are well under way. Victoria capital is identified with his enterprise.

EASTVIEW, ONT.—W. Leger will enlarge the planing mill he recently purchased here.

TRENTON.—Gill & Fortune are erecting a new planing mill in connection with their large lumber yards. A building 35 x 75 ft. is completed and machinery installed. All pulleys and shafting are underground, leaving the full floor space for machinery and work.

Let Us Make It

and save you the duty. We have skilled mechanics and a modern and completely equipped metal manufacturing plant, Automatic Screw Machines, Lathes, Drill Presses, Punch Presses, Power Shears, Plating and Polishing. We can make ANYTHING in metal and save you money. Send samples and get prices.

Dominion Telephone Mfg. Co., Ltd.
WATERFORD, ONT.

USE BASSITE

AS A SUBSTITUTE FOR TIN IN YOUR BRASS CASTINGS. WHY? BECAUSE BASSITE MAKES CASTINGS STRONGER, CLEANER, TIGHTER, SMOOTHER AND DENSER THAN IS POSSIBLE WITH TIN.

Does this difference in cost appeal to you?

Tin	at 36c per lb.,	quantity one ton,	\$720.00
Bassite "22c"	" " " " " "	" " " "	440.00

Actual saving in cost per ton, \$280.00

Let us ship you 100 pounds on approval. No pay, unless satisfactory.

MAKE A HIT WITH YOUR BALANCE SHEET AND ORDER NOW.

The Bassite Smelting & Mfg. Co.,
Incorporated
Cincinnati and Milford, Ohio

Building Notes.

BRANTFORD, ONT.—The Verity Plow Co., have let contracts for additions to its works costing \$60,000. The Penman Mfg. Co., of the same city, will commence shortly upon additions to its works to cost \$80,000. It will employ 400 additional hands.

TORONTO, ONT.—The Norcross Bros. Co. has been awarded the contract for the construction of the head office building of the Bank of Toronto. The cost will be about \$1,000,000.

LEVIS, QUE.—Plans have been filed with the Public Works Department of the Dominion Government for the \$4,000,000 dry dock and ship repairing plant here.

WINNIPEG, MAN.—Wood, Vallance & Co., wholesale hardware dealers, Hamilton, have purchased a site for a building in Winnipeg, the price being \$115,000.

SASKATOON, SASK.—The new warehouse of the Canadian Fairbanks Co. is almost ready for use. Plans are being prepared for a new 4 storey building 50 x 90 ft. to house Fairbanks-Morse manufactured goods and to include a machine shop for the repair of motors and machinery.

REGINA, SASK.—The Sawyer-Massey Co. is establishing western headquarters in Regina and work on their \$40,000 warehouse has been commenced. The concrete work is to be finished this fall and construction will proceed early next spring.

REGINA, SASK.—Plans for the erection of two large buildings, in connection with the Saskatchewan Methodist College, to cost \$250,000, have been approved.

HAMILTON, ONT.—The Canadian Westinghouse Co. will build an \$18,000 addition to their factory.

The Canada Steel Co. will locate their plant on the west side of Sherman Ave., at an estimated expenditure of \$400,000.

HAMILTON, ONT.—A. Hewitt, of Grimsby, is said to be contemplating the erection of a large modern hotel at Main and Hughson Streets.

VANCOUVER.—The B.C. Telephone Co. will erect a \$50,000 branch exchange for the accommodation of business in Mt. Pleasant district.

VICTORIA, B.C.—A new building to supplement the Royal Jubilee Hospital is being considered.

SASKATOON.—The Gray Carriage Mfg. Co., and the Campbell Fanning Mill Co., of Chatham, Ont., will erect one of the largest and most up-to-date distributing warehouses in Western Canada. The cost will be about \$50,000.

NELSON, B.C.—\$150,000 is the price at which W. Sharp & Son secured the contract for the erection of a C.P.R. summer hotel at Balfour, Kootenay Lake, 20 miles from Nelson.

WOODSTOCK, ONT.—The Linderman Dovetail Glue Jointing Co., and the Fibreboard Folding Package Co., are to erect buildings in Woodstock.

New Companies.

The Western Steel & Iron Co., Winnipeg; capital, \$300,000. Incorporated by leading business men of Winnipeg.

Clinton Motor Car Co., Clinton, Ont.; same directorate as Canadian Flax Mills, but interest taken by Toronto capitalists.

Joliette Steel and Iron Foundry, Joliette, Que., capital, \$250,000; to manufacture steel, iron, brass and aluminum products. Incorporators, S. Vessot, A. Durand and E. Hebert, all of Joliette. 6

National-Acme Mfg. Co.

The National-Acme Mfg. Co., Cleveland, Ohio, has commenced the erection of its new plant in Montreal, and has about completed the building of a four-storey addition to its Cleveland plant, 40 x 185 ft. This latter will be used for store and stock rooms, case hardening department, etc., and will enable the company to make considerable rearrangement of its present plant.

SIMONDS
(SI-MONDS)

Hack Saw Blades

For both Hand and Power Machine Use.

Steel blades for cutting steel. Hard, tough, even-tempered blades. Buy a gross of Simonds Hack Saw Blades today for trial, or write for quantity prices and discounts.

Simonds Canada Saw Co., Limited
MONTREAL, QUE.
St. John, N.B. Vancouver, B.C.
In the United States, Simonds Mfg. Co.



Try It—Before You Buy

We have such absolute confidence in the all-round superiority of the



Imperial Chuck

that to introduce it to your shop we will send you one, all charges paid, for 30 DAYS' FREE TRIAL.

Use it, test it any way you can think of, and if it won't do all we claim for it, send it back at our expense. But you are sure to join the company of delighted "IMPERIAL" users.

Write for Catalogue and Prices.

MADE IN CANADA

Ker & Goodwin
Brantford, Canada

STRENGTH AND POWER



21-INCH STEEL CHUCK

The S. E. Horton Machine Co.'s New Four Jaw Independent Chuck is not only the strongest, the most powerful, but the most durable lathe chuck of its class. Extra strong screws, large bearing surfaces, wider jaws and a careful distribution of metal are features of the improved design which count largely in effective service. We make a full list of sizes, and for exceptionally severe conditions steel castings can be furnished for the larger chucks.

Our New Pattern Face Plate Jaws have a wider range and better attachment facilities than any others.



WRITE FOR THE SPECIAL FOLDER.

The S. E. Horton Machine Company
WINDSOR LOCKS, CONN.
(NOT THE E. HORTON & SON CO.)

Practically no new machinery equipment will be required. The company reports that it is still well filled with orders and that its plant is running at full capacity. They report that prospects for Canadian business are very bright, a large number of their automatics having been installed in Canada.

Norton Company's Canadian Plant.

The Norton Co., Worcester, Mass., manufacturers of grinding wheels made from aluminum have opened a small factory at Chippewa, for the manufacture of carbide of silicon abrasives. The plant will probably be the nucleus of a Canadian industry to supply the Canadian trade. The main plant is at Worcester, Mass., where grinding wheels, oil stones, sharpening stones in great variety, glass cutting wheels, razor hones, etc., are made. Besides the abrasive plant the Norton Co. have operated an electric furnace at Niagara Falls, N.Y., the material being shipped from there to Niagara. In keeping with the growth of the company and the establishment of a small Canadian plant, it is of interest to note that a European plant has been put into operation at Wesseling, near Cologne, Germany.

Nova Scotia Steel Co. Absorb Harris Forge Co.

The Harris Forge Co., Ltd., which has carried on a large business at New Glasgow, N.S., has been absorbed by the Nova Scotia Steel & Coal Co., New Glasgow.

C. P. R. London Shops.

The C.P.R. has purchased a great deal of property in the north end of London. The houses are being removed and contractors are already at work on the many improvements.

To Manufacture Automobiles in Hamilton.

Publicity Commissioner Mullins announces that another big industry has been secured for Hamilton. It is the Acme Motor, Carriage & Machinery Co., and will be capitalized at \$1,000,000 to manufacture automobiles, taxicabs, carriages and road machinery. The new concern is a merger of the Baynes Carriage Co., of Hamilton, and the American Good Roads Machinery Co., of Goderich, and some Detroit automobile men, and the plant of the Baynes Co. will be greatly enlarged and the products made in Hamilton. They will specialize on a car that will likely be known as the Canada-30. The work of building the additions to the factory will be gone on with at once. The Baynes works will be extended in order that the bodies may be built in the factory. The new concern will employ about 150 hands, and the proposed directors are: S. Jones Phillips, Kennet Square, Pa.; F. W. Woods and R. F. Mancill, of Goderich, representing the American Road Machinery Co.; M. W. Best and D. P. Perry, Detroit, representing the automobile interests, and W. Southam, H. N. Kittson and P. D. Crerar, K.C., representing the Baynes Carriage Co.

New Industry for Medicine Hat.

The Alberta Iron Rolling Mills Co. has been organized at Calgary with the intention of supplying the Alberta trade. The capitalization is \$1,000,000 of which \$100,000 will be spent in erect-

ing buildings, \$10,000 in machinery and \$80,000 in plant.

\$10,000,000 Pulp Mill at Soo.

The prospects are bright for the establishment at Sault Ste. Marie of a ten million dollar pulp mill by a syndicate of American newspaper proprietors, including owners in Chicago and San Francisco. The Hearst interests, it is understood, are among the chief backers, and they may make a deal for the present mill of the Lake Superior Corporation.

New M. S. R. Shops.

Work has been started on the new construction and repair shop for the Montreal Street Railway Co. The works will be situated at Youville, north of the Villeray district. They are to be used for the construction and repair of street cars. The new works will be of large dimensions, the roof space alone of the main building having an extent of 115,000 square feet, in addition to which there are other erections with several miles of tracks.

The stores department situated to the west of the main building, will measure 148 feet by 55 feet, and the fact of its being cut off from the main part of the building will be of inestimable advantage in the case of fire.

The shop's outfit will include every up-to-date appliance and all modern equipment. The buildings will be of Laprairie brick and Montreal limestone. The general lines to be followed in the construction are plain, solid and fire proof.

Duponts Invade Canada.

VANCOUVER.—A \$10,000,000 merger of all the powder companies in Canada, with the exception of the Giant Powder Company, branch factory at Telegraph Bay, has just been effected. This deal marks the advent of the Dupont interests into Canada. It is understood that the interests of the Nobels and the Duponts in the holding company will be equal.

Duckworth-Boyer Co.

Aurelien Boyer, vice-president of the Duckworth-Boyer Engineering & Inspection Co., Montreal, has been named a director of l'Ecole Polytechnique, the applied science branch of Laval University. Mr. Boyer, whose grandfather, by the way, was the first superintendent of Education for Lower Canada, has always taken a good deal of interest in the cause of education. He will represent on the Board the graduates of the above named school, which shows the esteem in which this distinguished member of the profession is held by his confreres. It is interesting to note that the Duckworth-Boyer Engineering & Inspection Co., are the inspecting Engineers for the steel work entering into the construction of such large buildings as the New Windsor Street Station Extension, the Place Viger Station Extension, the Dominion Express Co.'s New Building in Montreal and the New Bank of Montreal Building in Winnipeg, Man.

Manufacturing Tool Steel.

The Canada Forge Co., Welland, manufacturers of iron and steel forgings, announce that they have taken up the manufacture of tool steel in addition to their regular line of forgings. High grade tool steel for every purpose will be produced by them.

Western Canada's Commercial Development.

Canada, commercially considered, is making rapid progress. Roughly speaking, the East manufactures and the West consumes. The farms of Western Canada are producing a gross income of \$250,000,000 annually and the men who make the farms produce this large sum of money, are free spenders of their income. They buy heavily of all lines of manufactured goods from farm machinery down to wearing apparel and nearly all of these goods are brought in from Eastern Canada, Great Britain and the United States. This producing and purchasing power of the West was strongly impressed upon the two hundred manufacturers from Eastern Canada who recently passed through the western provinces on their way to the annual convention of the Manufacturers' Association at the coast. They saw the great progress the west is making and the great opportunities the country offers for large increase of a traffic which is already enormous and highly profitable.

In the West, cities and towns are bidding for new enterprises by the establishment of municipal leagues and bureaus through which advertising campaigns are being vigorously pursued. Winnipeg, Manitoba, is an example of what can be accomplished by united efforts of this nature. Four years ago that city formed an official institution composed of representatives of several business bodies, headed by the city council, Board of Trade, Bankers' Association, etc., entitled the Winnipeg Development and Industrial Bureau. It is a perfect organization, that now has representatives of sixteen business bodies on its Board of Directors, having 8,700 affiliated members, 425 of whom are business firms who contribute to its financial requirements. These firms pay annual membership fees of \$20 and every year they appoint a delegation to wait upon the city council and ask for a sum they deem to be essential outside of members' contributions, to carry on the work of advertising for the current year. They get it too. In 1906, the city grant was \$1,500; in 1907, it \$3,000; in 1908, \$6,000; in 1909, \$10,000, and in 1910, \$25,000.

In welcoming the Canadian Manufacturers' Association to Winnipeg on September 13th, Mayor W. S. Evans in his remarks, directed attention to the growing importance of Winnipeg as a manufacturing city. Mayor Evans pointed out that in 1900 the value of the manufactures produced in Winnipeg was \$8,686,000. In 1905, it reached \$18,983,248 and, according to a census taken by the Civic Bureau, the annual output has now reached \$38,500,000. 14,000 hands are now employed who receive a monthly wage exceeding \$750,000, and \$20,000,000 is invested in industrial enterprises. Mayor Evans pointed out to the four hundred guests at this banquet, that there was room and opportunity for all, as the wholesale houses of Winnipeg handled in addition to the local manufactured output a total of over \$100,000,000 of goods made elsewhere during the year. Winnipeg has under construction one of the largest and best equipped power plants on the continent that will cost, when completed, \$3,500,000. The Dominion Government has in the past month officially opened St. Andrews Locks on the Red River, thus placing Winnipeg in direct water communication with Lake Winnipeg.

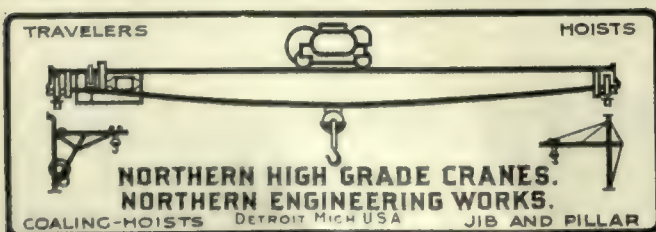

Canadian Department, ADVANCE MACHINE WORKS, Ltd., Walkerville, Ont.

THE BEST MELTER AND THE BEST MADE CUPOLA IS THE



LADLES

**NEWTON
CUPOLA**

TRUCKS

14 sizes Free Catalogue

NORTHERN ENGINEERING WORKS, Detroit, Mich., U. S. A.
Canadian Department, ADVANCE MACHINE WORKS, Ltd., Walkerville, Ont.

High Speed Steel; Its Treatment in Modern Practice

By J. J. Duguid *

The efficiency of the Machine Shop has Been Greatly Increased by the Introduction of High-Speed Steel. Mr. Duguid, in a Paper Read Before the Central Railway and Engineering Club, Toronto, Gives a Summary of Recent Advances in Machine Shop Practice due to Progressive Shops Adopting High-speed Steel. He Also Gives Valuable Pointers in Regard to Grinding, Forging, etc., Which, if Followed, Will Give Excellent Results and Greatly Increase the Present Output of Many Machine Shops.

I AM not going into the subject of high speed steel technically, but will give you my observations through using this steel and also what I have read about it. High speed steel got its name

done in them, they are therefore not carrying a heavy enough cut, neither can they be run to proper speed, and about 50 p.c. of the steel efficiency is all you are getting under these condi-

and some of these the most ridiculous. I believe if there was a uniform system in every shop for the grinding of tools (such as some shops have adopted) that it greatly increases the life of the steel also the efficiency.

3. The different speeds and size of cuts on uniform work and material. This is one of the most serious defects in the use of high speed steel or in fact any steel.

4. The use of belting not of proper tightness and belts that are worn out. I think you will agree with me that a great many manufacturers will use a belt until it all falls to pieces, although it may be decreasing the output of their high speed steel by 50 p.c. All belting that is driving machine tools should be adjusted with spring clamps as shown with sketch, so as to ensure proper tension and driving power.

5. The over hang of tools in tool rest causing excessive chattering and consequently breaking of tools.

6. The use of dull tools also the want of re-forging. The use of dull tools causes excessive heating destroy-

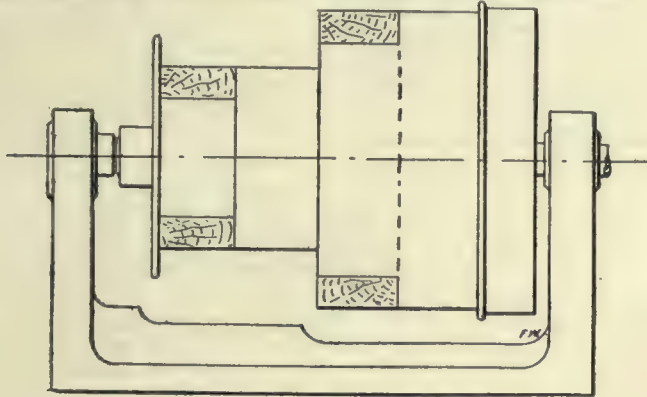

Fig. 1.—

no doubt from the fact that when it was first introduced the only way to get the increased efficiency of it was to run the machines at a high speed, as the old style machines were not built to carry heavy cuts, the driving belts and cones being too narrow to transmit the necessary power, and it was found if you increased these, as was done in some cases, as shown in Fig. 1, the other parts of the machine gave out under the strain. These parts then being strengthened up it was then found that the whole machine frame was not rigid enough and caused the tools to break on account of the vibration, and in the face of these facts all that could be done was to carry about the same size cuts with the high-speed steel as with old carbon steel, but speed up the machines. It was at this point that the manufacturers of machine tools saw the necessity of building more powerful and rigid machines, and to them should be given as much credit for increased output of machines as the high speed steel manufacturers. Although the great majority of machine shops are using high speed steel at the present time, I venture to say that very few of them are getting over 45 p.c. of the total efficiency of the steel, principally for the following reasons:

1. The great number of old out of date machines and heavy work being

tions. There are conditions, however, that old machines can be used to good advantage with the high speed steel

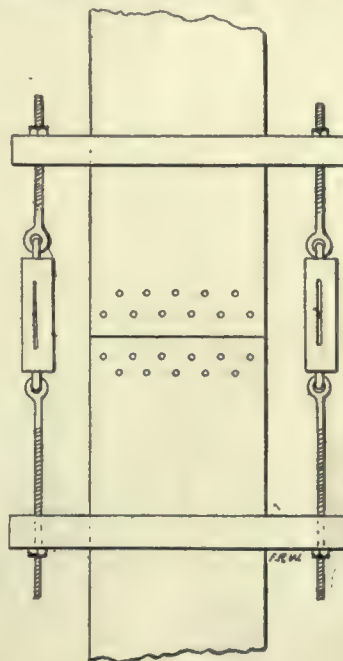

Fig. 2.—

and that is on repair work such as skimming up old piston rods, valve rods, etc.

2. The different shape of tools on uniform work. Workmen will grind machine tools about the same as ladies choose their hats, which is every shape

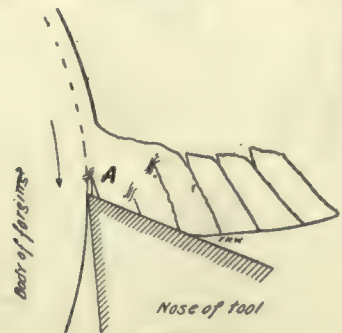

Fig. 3.—

ing them and also a great loss on account of the extra power required to drive the machine.

7. The want of proper supply of cooling water used, thereby allowing the tool to become overheated and fail.

8. The want of variable speed enough on the machines to suit the different diameters of work.

9. The use of too light tools on heavy work.

Now these are some reasons why we are not getting nearly the full efficiency from high speed steel, which must be quite apparent to those of us con-

* General Foreman, G.T.R., Toronto.

nected with machine shops, and are all defects that can be remedied with proper supervision. I will now try to describe to you the action of a tool and its wear in cutting metal. A great many of us imagine that it is the sharp edge of the tool the same as a razor that is doing the work, such however, is not the case.

Fig. 3 is an enlarged view of the action of a tool in cutting a chip from a forging at its proper speed, and it is therefore plain that in all roughing cuts the chip is torn away from the forging rather than removed by the action of cutting. The familiar

lip surface, ever presses against the metal. The clearance surface, as its name implies, is never allowed to touch the forging. Thus "cutting" with a metal cutting tool consists in pressing, tearing, or shearing the metal away with the lip surface of the "wedge" only under pressure, while in the case of the axe and other kinds of cutting both wedge surfaces are constantly under pressure. The enlarged view of the chip, tool and forging, shown in Fig. 3 represents with fair accuracy the relative proportions which the shaving cut from a forging of mild steel finally assumes with relation to the original

machines will not handle the heavy cuts of high speed steel. The cause of these variations in pressure is the making of the chip in sections. It would appear

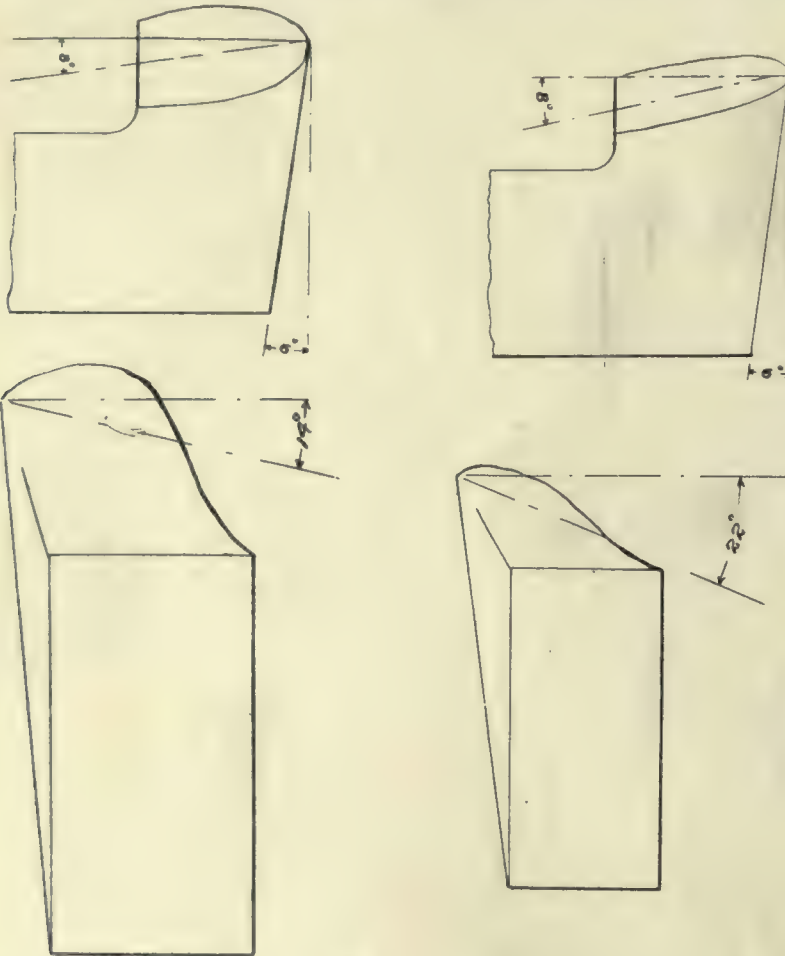

Fig. 4.

action of cutting, as exemplified by an axe or knife removing a chip from a piece of wood, for instance, consists in forcing a sharp wedge (i.e. one whose flanks form an acute angle) into the substance to be cut. Both flanks of the wedge press constantly upon the wood, one flank bearing against the main body of the piece, while the other forces or wedges the chip or shaving away. While a metal cutting tool looks like a wedge, its cutting edge being formed by the intersection of the "lip surface" and "clearance surface" or flank of the tool its action is far different from that of the wedge. Only one surface of a metal cutting tool, the

thickness of the layer of metal which the tool is about to remove. Now some of you may think this theory is all wrong, because you have noted that the cutting you have taken off a forging was of the same size as the depth of cut and the feed you used, but that only shows that you were not using a heavy enough feed and not running at a proper speed.

In experiments made to show the pressure of the chip on the tool cutting a chip of uniform size, that the pressure varied with the waive like regularity and that the smallest pressure was about two-thirds the maximum pressure and this is the reason that old light

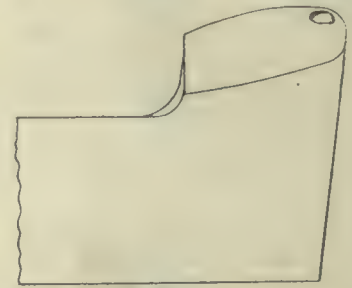

Fig. 5.—

that the chip is torn off from the forging at a point above the cutting edge of the tool, and this tearing off action leaves the forging in all cases more or less jagged or irregular at the exact spot where the chip is pulled away from the forging, as shown to the left of A. An instant later the line of the cutting edge, or more correctly speaking, the portion of the lip surface immediately adjoining the cutting edge, comes in contact with these slight irregularities left on the forging owing to the tear-

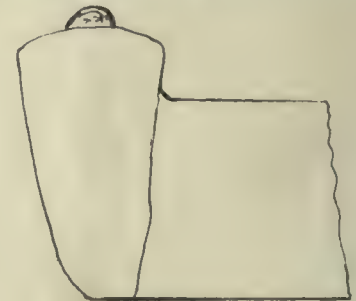

Fig. 6.—

ing action, and shears those lumps off, so as to leave the receding flank of the forging comparatively smooth. The cutting edge of the tool is continually in action, scraping or shearing off or rubbing away these small irregularities left on the forging, yet that portion of the lip surface close to the cutting edge constantly receives much less pressure from the chip than the same surface receives at a slight distance away from the cutting edge. This allows the tool to run at higher cutting speeds than would be possible if the cutting edge



Fig. 7.—

received the same pressure as does the lip surface close to it.

There are many things which indicate this tearing action of the tool. For

example, it is an everyday occurrence to see cutting tools which have been running close to their maximum speeds and which have under cut for a considerable length of time, guttered out at a little distance back of the cutting edge, as shown in Fig. 5. The wear in this spot indicates that the pressure of the chip has been most severe at a lit-



Fig. 8.—

tle distance back from the edge. Still another manner in which in many cases the tearing action of the tool is indicated is illustrated in Fig. 6, in which a small mass of metal is shown to be stuck fast to the lip surface of the tool after it has completed its work and been removed from the lathe. Then broken off, however, and carefully examined, this mass will be found to consist of a great number of small particles which have been cut or scraped off the forging, as above described, by the cutting edge of the tool. They are then pressed down into a dense little pile of compacted particles of steel or dust stuck together and to the lip surface of the tool almost as if they had been welded. In the case of the modern high speed tools, when this little mass of dust or particles is removed from the upper surface of the tool, the cutting edge will in most cases be found to be about as sharp as ever, and the lip surface adjacent to it when closely exam-

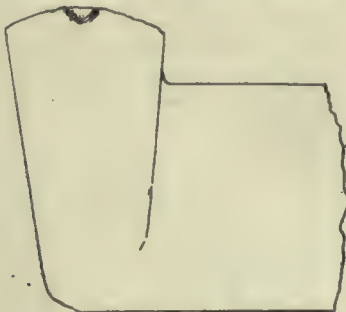

Fig. 9.—

ined will show in many cases the scratches left by the emery wheel from the original grinding of the tool.

With roughing tools made of old-fashioned tempered steel, and which have been speeded close to their "standard speeds" in most cases after removing this "dust pile" from the lip sur-

face the cutting edge of the tool will be found to be distinctly rounded over. And in cases where the tool has been cutting a very thick shaving, the edge will be found to be very greatly rounded over, as shown in the enlarged view of the nose of a tool in Fig. 7.

With carbon steel tempered tools at standard speeds the cutting edge begins to be injured almost as soon as the tool starts to work, and is entirely rounded over and worn away before the tool finally gives out, but the tool works well in spite of its cutting edge being damaged. While with high speed tools at standard speeds, the cutting edge remains in almost perfect condition until just before the tool, gives out, when even a very slight damage at one spot on the cutting edge will usually cause the tool to be ruined in very few revolutions.

Carbon tempered tools and also, to a considerable extent, the old-fashioned

is next to and constantly rubs against the cold body of the forging, and is materially cooled by this contact.

Whether the lip surface be ground away at high speeds or at slower speeds, the nose of the tool is generally "ruined" in a very short time after the cutting edge has been so damaged that it fails to scrape off smoothly even at one small spot the rough projections which have been left on the body of the forging by tearing away the chip. The moment the body of the forging begins to rub against the clearance flank of one of these high-speed tools at or just below the cutting edge, even at one small place, the friction at this point generates so high a heat as to soften the tool very rapidly. After a comparatively few revolutions, the cutting edge and the flank of the tool beneath it will be completely rubbed and melted away, as shown in Fig. 8. A tool

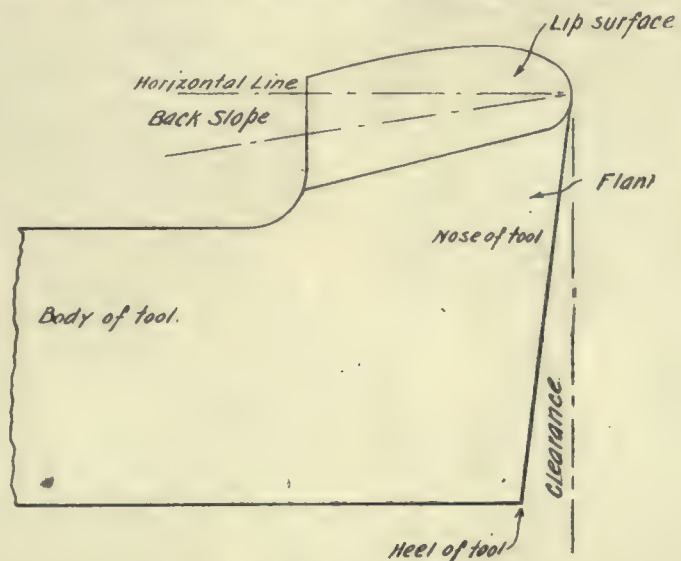

Fig. 10.—

self-hardening tools such as Mushet, when run at their "standard" speeds, pass through the following characteristic phases as they progress toward the point at which they are finally ruined "Rounding of the cutting edge," "mounting of the steel upon the lip," and the "rubbing away beneath the cutting edge." Long before the tool is ruined the fine particles of steel or dust scraped off by the cutting edge, begin to weld or stick to the lip of the tool and mount upon it sometimes from 1-16 inch to 1/4-inch in height, as shown in Fig. 6. As stated above, in the case of modern high speed tools the damage caused to the tool through the action of cutting is confined almost entirely to the lip surface of the tool. Doubtless also the metal right at the cutting edge of the tool remains harder than it is directly under the centre of pressure of the chip, because the cutting edge

which was still in "fair" condition when removed from the lathe, although showing some slight signs of ruining, is shown in Fig. 9. The above characteristic of holding their cutting edges in practically perfect condition while running at economical speeds up to the ruining point is a valuable property of the high-speed tools, since it insures a good finish, and the maintenance throughout the cut of the proper size of the work, without the constant watchfulness required on the part of the operator in the case of old slow-speed tools with their rounded and otherwise injured cutting edges, which when run at economical speeds were likely at any minute to damage the finish of the work.

But when one of these high-speed tools is nearing its ruining point, a very trifling nick or break in the line of the cutting edge will be at once noticed by

its making a very small but continuous scratch, projecting ridge, or bright streak, on the forging, that is, upon that part of the forging from which the spiral line of the chip has just been re-

Heavy cuts and heavy feeds have become specially necessary because superintendents of shops have found it more economical to reduce forging to size by the heavy modern tools and high-speed

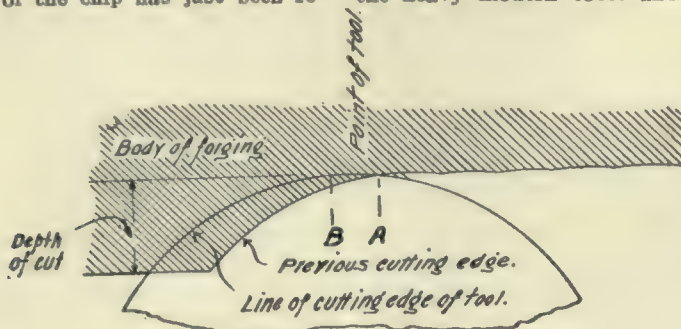

Fig. 11.—

moved, thus warning the operator of the impending break down of the tool.

Proper Speed to Run High-Speed Steel.

There can be no uniform standard for the speed for the reason that even on the same class of material there is a wide variation in the speed that it can be economically worked and then again a forging of large dimensions can be cut at a greater number of feet per minute than a small one on account of its capacity for carrying of the heat generated, and the tool is not cutting on the same point on the circumference so often on account of the larger diameter. A cutting speed which will cause

steel, that under the hammers in the forge shop, and are therefore having much more material to remove than they formerly did.

The following are some tests I have made from time to time with high-speed steel:

1st. Locomotive driving axle, speed, 75 feet per minute; reduction in diameter, 1.5-1.6 in.; feed, 3-16.

2nd. Old locomotive steel tyres, two tools; depth of cut, $\frac{1}{2}$ -in.; feed, 5-16-in.; speed, 28 feet per minute; metal removed, 155 lbs. in 12 minutes.

3rd. Six pair of old and two pair new 63-in. locomotive driving tyres turned in 5 hours 50 minutes; average time, 43.75 minutes each; average cutting time, 35.87 minutes each pair; speed from 14 to 21 feet per minute; 5-16 feed; depth of cut, $\frac{3}{8}$ -in.

4th. Forged steel shaft, 16 in. diameter, 13 feet long; feed, $\frac{3}{8}$ -in.; depth of cut, 1 1-16-in.; speed, 50 feet per minute; the tool took this cut entire length with one slight grinding.

Now, I do not pretend to say that this is the average cutting speed for high-speed steel, but only to show how much high-speed steel will do.

Regarding the shape of turning tools, you will note in this paper that I have only referred to standard roughing tools. The shape of tools is of just as much importance as the material they are made of, and must have the following requirements:

1st. To have the work true and sufficiently smooth.

2nd. To remove the metal in the shortest possible time.

3rd. To do the largest amount of work with the lowest cost of grinding and forging.

4th. To be adapted to the largest variety of work.

5th. To remove the metal with the lowest horse-power.

6th. It must be shaped to have the point as strong as possible and cutting edge supported.

One difficulty in practice is to have always a supply of sharp tools for the machinist, and it is better to have a few shapes and plenty of tools, than to have many shapes and not enough of any one kind. These should be ground to templates, if they must be done by hand; but an automatic tool grinder will pay even in a moderate-sized shop.

Fig. 10 represents a good standard roughing tool, and note that the lip surface is raised above the body of the tool; this is to increase the life of the tool before being reformed and also to reduce the grinding to a minimum.

Curved Cutting Edge Best.

The curved-edge cutting tool is best for roughing in all cases, for the reason that it removes a shaving which varies in its thickness at all points, and that the part of the cutting edge which finishes the cut is removing so little metal that it remains sharp even though most of the cutting edge has been worn or broken away. The effect of this is shown in Fig. 11. This indicates that the accuracy and finish of the work depend on that part of the edge from A to point B remaining sharp and uninjured.

The curved face, as you will note on Fig. 11, also puts the heaviest part of

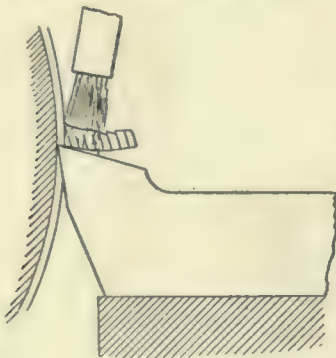

Fig. 12.—

a given tool to be ruined at the end of 80 minutes is about 20 p.c. slower than the cutting speed of the same tool if it were to last 20 minutes. On the whole it is not economical to run roughing tools at a cutting speed so slow as to cause them to last for more than one and one-half hours without being re-ground, this, of course, refers to working on ordinary machinery steel.

High speed can be used on forgings up to 110 feet per minute, but only on short cuts and light feeds on such work as bolts, pins, etc., but when working on heavy rigid forgings that require heavy reduction to bring them to desired size it is more economical to increase the feed to the limit of the machine capacity and reduce the feed to suit, as you will find that by reducing the speed 25 p.c. the feed can be increased 50 p.c.

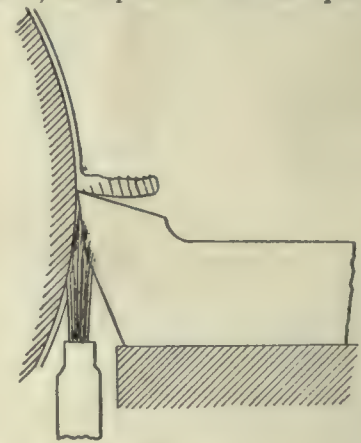

Fig. 13.—

the cutting back from the point, and where the tool is heavy and can carry off the generated heat. Standard tools should have a clearance angle of 6 degrees for all classes of material, and a back slope of 8 degrees for all material, and a side slope of 14 degrees for cast iron and hard steel, and 22 degrees for medium and soft steel.

The lip angle is determined by making it just blunt enough to stand the cut without crumbling or spalling. A sharp side slope is better than a sharp back slope, because the tool can be ground more often without weakening it, the chips run off better, the strain is more on the base of the tool and it is easier to feed.

It may seem strange that the lip angle for cutting cast iron is not as keen as

for the softer steels, but the highest cutting speeds, with equal depths of cut and feed, can be obtained by using the angles given. The thickness of the shaving has the most important effect on the cutting speed, much more so than the depth of the feed. This is the reason for the advantage of the large curve on the cutting edge, as this decreases the thickness of the shaving, as can be seen in Fig. 15.

The clearance angle of any tool is the most important and if it is more than 6 degrees it will not properly support the cutting edge, which will break and cause a fracture of the tool.

Grinding of High Speed Tools.

I believe more tools are ruined by careless grinding than by any other means, and it is a peculiar fact that

A heavy stream of water should be thrown directly on the chip as shown in Fig. 12 and not up the chip as in Fig. 13. even though this might seem the correct way. Experience has shown that throwing it on the chip takes away the heat fastest. A guide to the amount of water to be used is that three gallons a minute is right for tools 2 x 2½ inches, and less for smaller tools. The gain in efficiency by the use of water is given as:

40 per cent. with modern high-speed tools.

30 per cent. with old-style self-hardening tools.

20 per cent. with carbon-tempered tools.

16 per cent. in cutting cast iron.

In some shops various cutting compounds or lubricants (as they are called) are used on lathes and planers, but

paper, and it must be remembered that the shape not only increases the life of the tools and is easier on the machine, but there is also a marked difference in the power required.

Forging.

For forging high-speed steel an ordinary forge fire will serve, though, indeed, better results may be expected if better apparatus is used. The principal thing is to secure the required heat, and to keep air currents away from the tool in heating. For small tools of the simpler sort, good results are sometimes obtained from an ordinary open fire. The result is, however, much more likely to be satisfactory if a sort of a hood is built over the fire. This serves to prevent the radiation of heat and the circulation of air currents, and is a necessity in heating tools of any size. It also makes it easier to bring up the heat gradually, and to apply it uniformly on all sides of the tool, so that the heat penetrates uniformly. This is an important point. Unless the mass of steel to be wrought is uniformly hot throughout, it will work unevenly in forging, with the result that internal strains are set up, which may ruin the tool when it is put at work, if not before. Though the heating is to proceed gradually, in the sense that it must be regular, it may go on quite rapidly. In fact, it should be done as rapidly as may be without burning projecting edges or corners. Unless this is done the heat soaks up into the neck or shank, and when hardening takes place this important part of the tool loses some of its toughness.

The Right Heat.

However, the fire must not be too hot, for in that case the outside is likely to be burned before the interior is thoroughly heated. In any event there is a likelihood that the toolsmith may be deceived into thinking the whole mass properly heated when in fact only the outside is hot enough for forging. If the interior has not reached a bright red heat, or 1400 degrees F., it is not ready for hammering. Of course it is impossible to know the condition of the interior, except through its behavior under the hammer after removal from the fire, and it is largely a matter of experience to determine the proper time during which a tool is to be heated.

Heating for Hardening.

The extent to which the heating is to be carried for hardening may vary within narrow limits, just short of melting point. The steel will then be at a dazzling white, and just beginning to flux. Some brands reach this point somewhat short of the extreme white color. Where this is the case, care must be

Continued on Page 41.

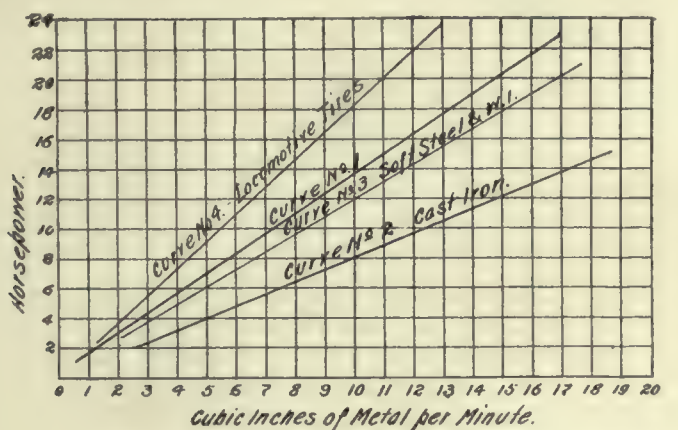

CHART OF HORSE-POWER REQUIRED TO REMOVE METAL

FIG. 14.

which high speed tools can be run at a high temperature in work without injury.

They are easily destroyed on an emery wheel, and if the tool is pressed firmly against the wheel and allowed to heat up you will find small cracks started in the steel. In a great many shops high speed tools are ground on a dry wheel, but I think this is a mistake, and again when a wet wheel is used there is not a sufficient amount of water used. Experience has shown that not less than four gallons of water per minute should be used. Automatic grinders should be used for heavy grinding on all high speed tools, as the pressure on the wheel is uniform and the shape of the tools are kept uniform, and much better results will be obtained in turning out work.

Use of water on Material where Turning.

Water used on a high speed steel increases its capacity in every case and the gain practically the same for all qualities of steel, and for removing thin or thick chips. With high speed tools a gain is made by using water on cast iron, contrary to most beliefs.

there is no extra efficiency using this material on an engine lathe or planer, any further than it does not rust the machine. However, these compounds give first-class results on drills, screw-cutting machines and turret lathes, but with these you require both a cooling and lubricating mixture, whereas, on ordinary turning all that is required is cooling.

Horse-power Required Using High-Speed Steel.

With the advent of high-speed steel the power required to drive the machines to their maximum increased enormously, for example:

- a 12-in. lathe increased from 1 to 4 horse-power.
- a 30-in. lathe increased from 5 to 20 horse-power.
- a 72-in. lathe increased from 15 to 50 horse-power.

and in a test made with a 72-in. lathe with a cut 1½-in. drip and ¼-in. feed and 30 feet per minute, required 75 h.p.

Fig. 14 shows the horse-power required to remove metal with roughing tools of the shape mentioned previously in this

A Day's Ramble Through the M.C.R. Shops at St. Thomas

By Fred. H. Moody

Every Shop has its Ways and Means of Meeting Exigencies That Arise in the Shape of Unusual or New Jobs, but the Railway Repair Shop has an Exceptionally Large Number of Such Special Tools. The M. C. R. Shops, Under the Direction of an able Staff of Men, have Developed Numerous Special Methods and Devices, a Number of Which Were Picked up by the Writer in a Recent Trip Through the Shops, and are Here Given with Some Detail, as They Will Doubtless Prove Beneficial to Machinists, in General, in Developing Initiative for Undertaking New Jobs.

PART I.

The railway repair shop usually proves to be a store house of excellent ideas of doing work, for, from the class of work to be done many special operations are made, necessitating special tools and machinery. The saying that "necessity is the mother of invention" applies very forcibly in such shops, for when necessity arises, the tools essential to the work, are usually forth-

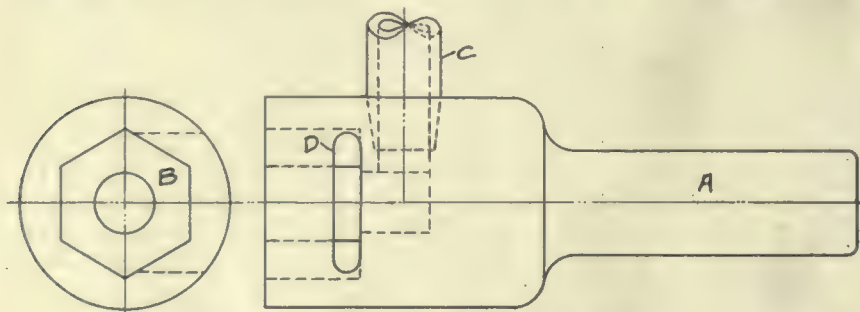

Fig. 1.—Self-cleaning Nut Holder for Turret Lathe.

coming. The Michigan Central repair shops afford an exceptionally good example for tools of all kinds abound, the majority of them showing much ingenuity.

Machine Shop.

The machine shop invariably has a number of special methods, and this shop proves to be no exception. Fig. 1 shows a nut holder for use in tapping nuts on the turret lathe—brass nuts in particular. The special feature is that it is self-cleaning. The shank A is held in the turret head, and the nut in recess B. A blast of air is admitted by a valve to gripe C, which blows into the holder removing the chips. The intensity of the blast can be so regulated as to keep the holder always clean with no interfering chips or cuttings. The chips and blast are let out through side passage D during the tapping operation.

The turret-lathe has developed a number of special tools in these shops, Fig. 2 being representative of one class of such. As can be seen, it is a forming tool for boring and turning the nipple A, the only other operation required being the bevelling of the end by the cutting-off tool. In form, it is like a hollow mill with an inserted formed tool to do the internal work. The tool

consists of a tool steel body B, of which the shank C is held in the turret head. The mill is bored out to the external size of the finished nipple A at D, the face of it finishing the shoulder E. An inserted tool F, ground like a flat drill to correspond to the two internal diameters, bores as desired, this tool being set as desired by set screw G, bearing on the shank of the tool. The whole mill can be dissembled for

the approximate size shown. The reamer is turned to the finished tap, and and threaded with a type of worm thread, with a pitch of three. The valve stem is first drilled, and then this rough reamer inserted, all these operations being done on the turret lathe. Each of these teeth presents a separate cutting tool to the work reducing it very rapidly, in fact, as heavy a feed may be used as with the drill. After this roughing operation, the usual finishing reamer is employed.

Separating a tapered pin connection, such as that shown in Fig. 4, usually presents considerable difficulty, as the taper key used to hold the two parts A and B together, forces the two parts together very tightly. The following method is employed to separate them: After the removal of the key two pieces shaped like C and D are inserted. C is cut out at the centre, and D has a central projection as shown. The wedge E when driven down, forces outward on the projection of D and loosens the two parts, which can then be removed. This is much preferable to the customary method of loosening by tapping on the outer shell, the latter method also mars the work.

Many and divers are the bolt hole facing tools in use, but the one employed at these shops, is second to none. While it is not new in principle,

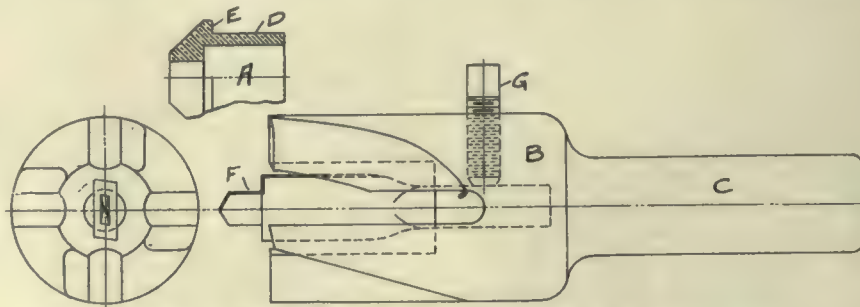

Fig. 2.—Hollow Mill for Making Nipples on the Turret Lathe.

in other mills of larger size. This plan has been developed to a considerable extent.

Fig. 3 shows an excellent form of roughing reamer used for roughing out the valve stem connection shown at A, Fig. 4. Referring to Fig. 3 it can be seen that the reamer is formed from round stock flattened and tapered to

it is so seldom seen, that it is worthy of description. The general construction, feed, and other details, are so well understood, that a description is unnecessary. The interesting feature lies in the cutter A, which is turned up, and the teeth milled out from a high speed steel block. In place of being keyed in the usual manner, the centre

hole is bored flat on one side, and the bar itself flattened to correspond. This acts as the drive for the cutting tool. Being made of high speed steel, it

light in construction, 1 inch cuts with 1-16 inch feed can be taken on cast iron locomotive wedges.

A convenient vise for planing thin

supported. The cast iron body A, which swings between lathe centres, has the two screws BB passing radially through the centre. The brass is set in on this, and the end set screws CC tightened down loosely, holding the brass against the collar D of the jig. The brass is then centralized in the usual manner by adjusting screws BB, and tapping the brass from side to side, when the screws C are tightened down and the brass machined. The principal feature of the jig, is the ready manner in which the second and succeeding brasses of a set may be chucked. After the first, B and B are correctly set so the simple side adjustment is all that

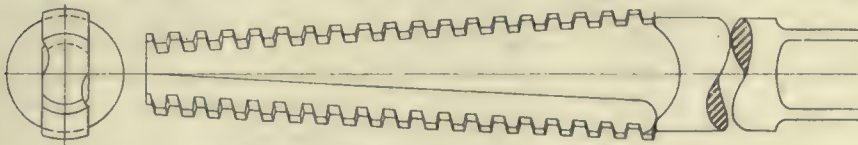

Fig. 3.—Rough Reamer for Turret Lathe.

stands a good deal of abuse in the shape of being roughly used on the hard skin of the casting. It is principally used for facing the bolt holes in the locomotive saddle, i.e., the connection between the cylinder and boiler.

Where similar wedges must be produced in sets, a simple method of setting them up must needs be employed, if rapid and accurate work is to be expected. The jig shown in Fig. 6 meets these requirements admirably. They operate in pairs. Essentially, they con-

strips is shown in Fig. 7, and is employed for planing the thin valve pieces used in locomotive balanced D slide valves. The jig consists of a body A, on the top of which the work is secur-

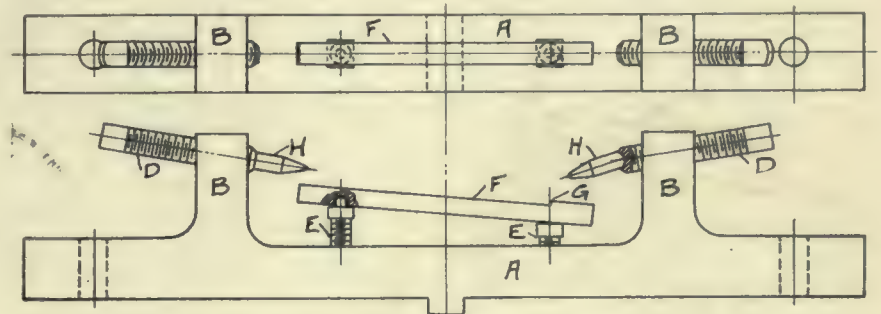

Fig. 6.—Planer for Planing Wedges and Slippers.

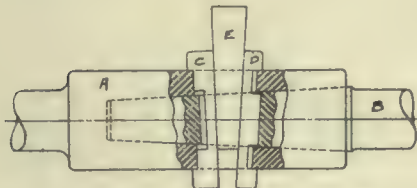

Fig. 4.—Removing Valve Steam from Valve Rod.

sist of a steel forging A with a projection to fit the planer slot, and two lugs BB through which are the set screws DD. In the base, are the two screws EE with pin tops, which fit into holes in a strip F. In use, the screws EE are so adjusted as to give the proper taper to the shoe to be planed. The shoe is inserted into the jig, and is shoved against the shoulder which lines up the work. To hold the work more securely than it would be possible with the use of set screws alone, intermediate pins HH are used, which are of hardened steel pointed at the end which touches the work, and round to fit the set screw at the other end. They can be set at any angle to bring a considerable downward pressure

ed. The body has a groove B, to fit the planer to which it is bolted. Two stationary projections CC of thin bar iron align the work, and it is held on the other side against these projections

is necessary, the brass swinging on the tips of screws BB. The whole is driven through the double lug E, by dogs on the lathe face plate.

Fig. 9 is from a data sheet gotten

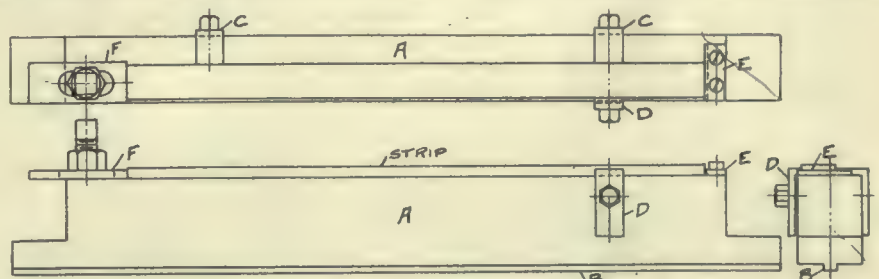

Fig. 7.—Planer Vise for Valve Strips.

by the piece D which is tightened down on the strip. The stop E is a hardened steel strip knife edged against the strip being planed. It is held at the other end by piece F, which has a bolt slot.

out by the apprentice department. Each of the different shops of the New York Central lines, gets out several such each year. This one, while not exactly new, has never been seen by the writer in this form, and ought to prove of value in determining the nature of a ferro metal when no other means is at hand.



Fig. 5.—Bolt Hole Facing Tool.

on the work. To set up, the left set screw D is screwed up with its intermediate pin, against the work, shoving the wedge over to shoulder G. The other set screw D is then tightened down on the work. The shoulder G aligns it perfectly. While apparently

The bolt is tightened down loosely and then F is tapped up tight when the bolt is tightened down securely. It is thus held firmly from all sides.

A handy jig for turning locomotive brasses is shown in Fig. 8, the broken lines indicating the way in which it is

For testing boilers with hydraulic pressure, a handy pump has been rigged up, utilizing old parts. The pump itself has a 3-inch plunger, and the power end consists of an old 8-inch air cylinder. Using the slip air pressure on this produces an extremely high hydraulic pressure for the boiler, the latter being regulated at will by the air pressure.

On the boring mill, in place of the usual type of movable chucks, they have special chucks made from steel forg-

ings, and which will therefore stand the great strain put upon them, when holding heavy steel locomotive tires. Each

bar, as the hole in the cutter, Fig. 2, is central, making the cutter reversible. As new ends are often required on the

body B of the jig, is held in the adjustable arm of the grinder, which can be set for 70 degrees, the angle of the cut—a tapered pin in hole A, the cutter being held against the back shoulder. The

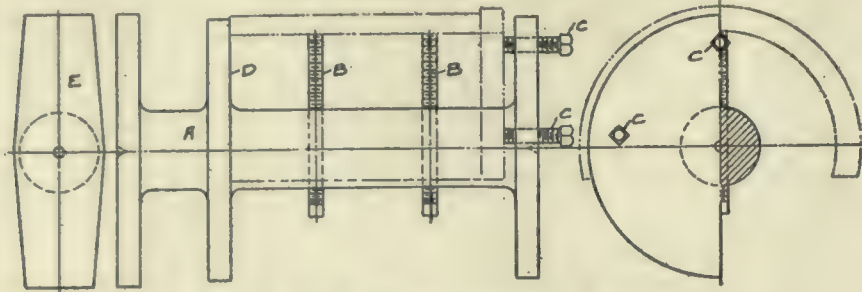

Fig. 8.—Jig for Turning Locomotive Brasses.

chuck has a dowel hole, which corresponds at different points on the boring mill table, with similar holes. The

cutter bar, from the fact that the old ones twist off or become broken, etc., a jig is used, which makes central

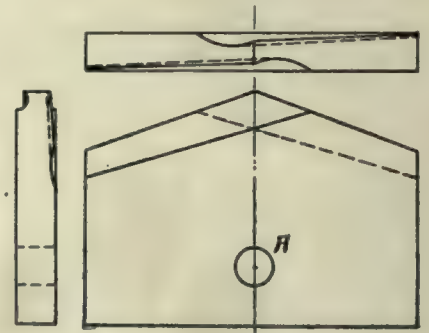

Fig. 2.—A Good Cutter Bar.

ter. D is an arm that extends from end to end through the jig body, and holds the cutter. C and C are two holes on the same circle, 180 degrees apart. After setting for, and grinding one face of the cutter, the spring pin E may be pulled up, and the arm D containing the



Fig. 9.—Spark Test.

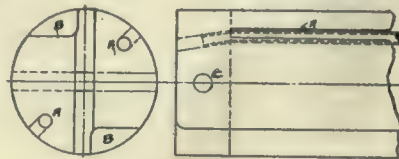

Fig. 1.—A Good Cutter Bar.

drilling very easy. This jig is shown in Fig. 3. The bar is shoved in from the left, in a bush if required, the end slot going up against the cross-piece, so that the hole C in Fig. 1, is always the same distance from the bottom of the groove. No trouble is thus experienced in reproducing ends for any size as a range of bushes are always on hand.

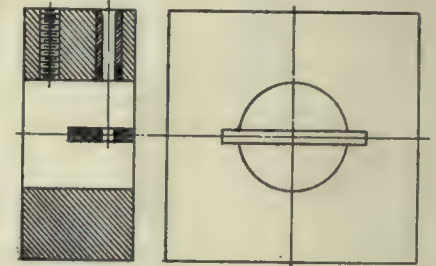

Fig. 3.—A Good Cutter Bar.

The particular feature about the cutter-bar is the cutter, shown in Fig. 2, which is made standard in every way and is formed of high speed steel. A special jig to take any size cutter is used to drill the hole A centrally and the same standard distance from the back adaptable to any size, the cutter is tap-

swung 180 degrees so that the pin E is in the diametrically opposite hole, so that the cutter can be ground exactly the same as the other face. Similarly the grinder table can be set for the sides micrometer measurements. Thus any cutter will fit either way into a cutter

dowels being used, relieves the tightening bolts from any strain, and prevents slipping of the chuck on the table.

GOOD CUTTER BAR.

Fig. 1 shows the tip of an excellent cutter bar used in the shops of the London Machine Tool Co., Hamilton, the cutter for which is shown in Fig. 2. In operation the bar is usually attached to a support on the carriage of the lathe, and centred by a steady rest, the carriage feeding it forward into the work. A steady stream of water is forced onto the cut at all times by two imbedded brass tubes AA, down the side of the cutter bar, which is 1/8 inch smaller than the bore. This heavy stream of water, keeps the tool cool, and at the same time drives out the chips through the longitudinal cut-outs BB.

The pin C is absolutely central in the

as with the bar. Then in another jig, erod and the lip cut by a 2-pitch stocking miller in both sides by reversal. It will be noticed that the lip becomes deeper towards the centre, caused by the special design of the jig. Its special feature is its flexibility for machining any sized cutter.

After tempering, the blades are sharpened in a Gisholt grinder, the special jig shown in Fig. 4, being used. The cutter is held in the left hand groove by

bar. But, to insure against any possible which can be symmetrically ground to error, the parts are all numbered to fit one way.

The whole cutter-bar, cutter, and necessary jigs, reflect credit on the designer, as they are adapted to a wide range of work. The standard features of the bar and cutter, which make them mutually interchangeable is a very prominent and noteworthy feature.

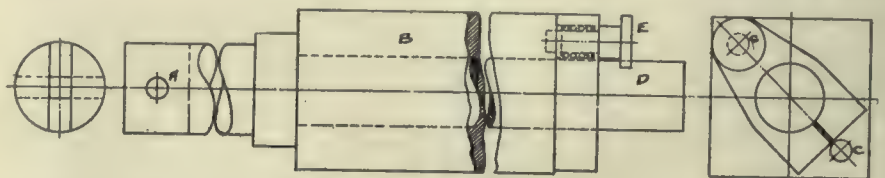

Fig. 4.—A Good Cutter Bar.

HIGH SPEED STEEL.

Continued From Page 37.

taken that sharp edges and angles of the tool are not melted down. As in forging, it is necessary to see that the heating proceeds uniformly, and reaches through the entire mass of metal.

The Air Blast.

As most of the high speed steels harden by mere exposure to air, little apparatus is absolutely required in addition to the heating furnace; and some very good results have been obtained with none at all. The hardness of the steel depends considerably, however, on

the rapidity of the cooling,, therefore mere exposure to the air and slow cooling is not always satisfactory — for many purposes, indeed, it is very unsatisfactory. Most makers recommend the air blast for hardening. As this furnishes a continuous supply of good air in rapid motion, the result is generally good.

Since part of the latent heat in the air is extracted in the process of compression, compressed air is better for the purpose than that from a blower. The convenience and simplicity of this agent, when available, recommends itself.

The Different Uses of High Speed Steel.

When high speed steel was first introduced users were of the opinion that it was only fit for roughing tools. This was a fact at that time as the edges of the tools would not keep sharp enough for the finer classes of tools. However, since that time the manufacturer of high-speed tools have improved it so that at the present time it can be used, and is used, for milling cutters, reamers, cold saws, and, in fact, all machine shop tools, with good success, and a great increase of efficiency over carbon steel, and at the present time it is also used for the very finest of tools, even razors.

Machining a 12,000 h.p. Generator at the Canada Foundry

The Contract Between the Ontario Hydro-Electric Commission and the Ontario Power Co. at Niagara Falls has Necessitated the Making of Three 12,000-h.p. Generators, the Contract for These Being Secured by the C. G. E. The Machine Work on These Large Machines is Being Done at the Canada Foundry, Toronto. As Many Large Jobs are Now Being Done in Canadian Shops, the Machining and Handling of These Large Generator Frames Cannot Help but be of Interest.

THE Ontario Power Co., Niagara Falls, in order to supply the power required by the Hydro-Electric Power Commission, have placed a contract with the Canadian General Electric Co., Toronto, for three new units of 12,000 h.p. These are 3-phase, 25 cycle, 12,000 volts and will run at 187½ r.p.m.

The machining of these three large generators was done at the Canada Foundry, Toronto, under the supervision of Mr. Loach, general foreman. An idea of the size may be gained by reference to the accompanying illustration.

Setting on Planer.

The first operation was to plane the jointing surfaces of the two parts of the frame. The joint line was set up parallel, but on account of the large diameter of the hubs, it would not pass through the housings. One end, was, therefore, planed first, then it was turned and reset against an angle plate and other end finished to angle plate, giving a perfect line.

Slotter and Drilling.

After the planing it was taken to a locomotive frame slotter and slotted for the 1½ in. keyway on both sides, the two keyways being done at once.

It was then drilled on two drills at once. There are four 2 in. holes on each end for 2 in. turned and fitted bolts with case-hardened heads. The two parts were then assembled in a wheel pit and the keys fitted.

The bore of the frame is 14 ft. It was machined to size on an 18 ft. boring mill. This is a 20 ft. 4-inch job, and

was done on the 18 ft. mill by running the housing back, taking off small parts and erecting parallel strips on table of boring mill extending out to take in the job. The mill is a back geared powerful mill driven on face plate built by John Bertram & Sons Co., Dundas. The mill operated successfully under the load of 38,040 lbs.

After boring, which had to be done to

within .001 in., to keep air space in generator accurate to give high efficiency, it was put on a planer and the legs that set on the base were accurately planed. This was done by setting up to the centre line of bore as in many cases a casting has to be moved from plane centre of casting. In this method a correct height from base for bearing is obtained.

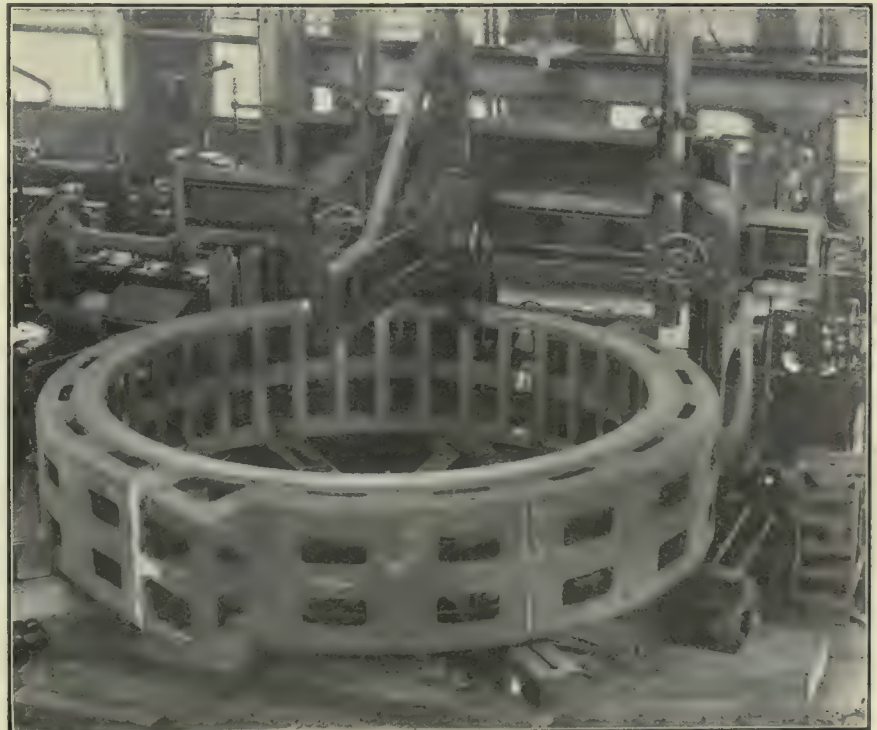

Machining 12,000 h.p. Generator Frame at Canada Foundry, Toronto.

Dec 10 p42

Lake Superior Corporation and Subsidiary Companies

Large Additions are Being Made to the Various Interests of the Lake Superior Corporation, Which Will Make it One of the Largest Steel Plants in America. Altogether 7,840 Men are Given Employment at the Present Time. Last Year was a Record Year With the Company, but 1911 Will, no Doubt, Show Increases. The Enlarging of This Industry Shows the Satisfactory Outlook for the Canadian Steel and Iron Trade.

THE Lake Superior Corporation is undergoing a period of prosperity which necessitates many large additions to the plants. Among those affected are: Dominion Tar and Chemical Co., tar distilling plant; shingle and keg factory in connection with the Algoma Steel Co.; Soo saw mills; Bi-product coke oven plant; Docks, coal, rail and ore; Algoma Central Railway; Algoma Steel Co., blast furnaces; Gas washing plant; Gas Engine Power Plant; Open Hearth Department; Bessemer Department; Blooming Mill; Rail Mill; Finishing Mill; Merchant Mill; Algoma Iron Works; Sault Ste. Marie Pulp & Paper Co., and Lake Superior Power Co.

Tar Distilling Plant.

The plant of the Dominion Tar &

Chemical Co. is under construction. This plant will employ 50 men to start with and will manufacture out of the coke oven tar, hard pitch for briqueting purposes, creosote for the preservation of timber and light oils.

Shingle and Keg Factory.

The Algoma Steel Co. have nearly completed a factory for the manufacture of shingles, kegs and boxes to be used in shipping material such as spikes, bolts, nuts, and other steel products of the new Merchant Mills. This plant was formerly a hardwood veneer plant and is being converted into the above.

Soo Saw Mill.

The Soo Saw Mill has a capacity of 250,000 ft. per day, 40,000 shingles per day, 35,000 pickets per day and 60,000

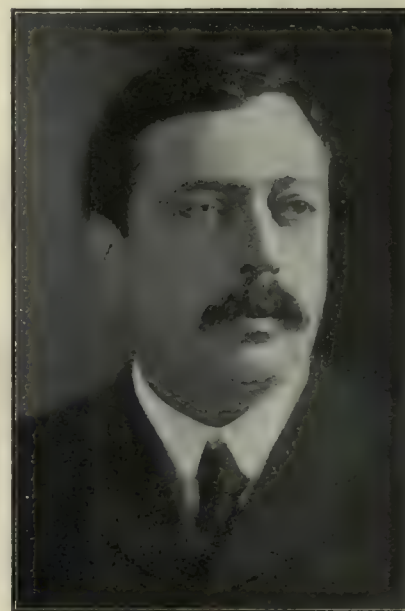

T. J. DRUMMOND,
President Lake Superior Corporation.

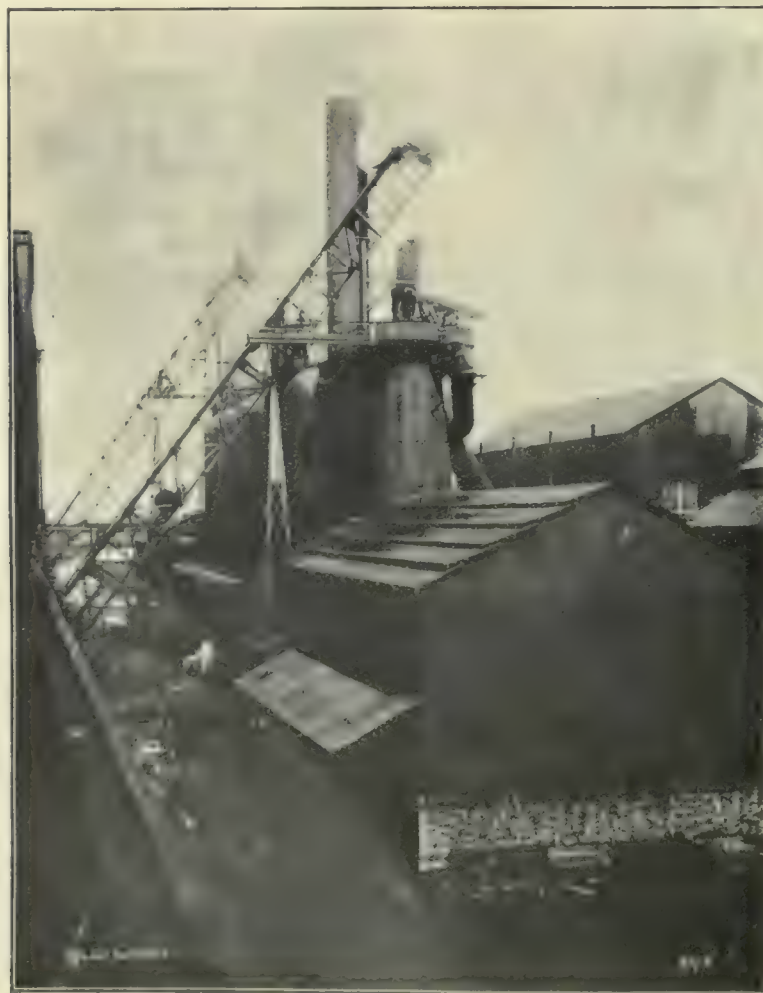

Blast Furnace Plant, Lake Superior Corporation, Sault Ste. Marie.

laths per day giving employment to 180 men. There is now 10,000,000 ft of lumber on hand, all sold, being shipped as fast as seasoned. The mill is operated from March 1 to Dec. 1, the season's cut being 26,000,000 ft. Logs are cut on Algoma Central grant lands and brought to the Soo by Algoma Central Ry. and by water.

By-product Coke Oven Plant.

This plant is under construction and will employ 125 men. There will be 110 Koppers type ovens installed by H. Koppers, Essen, Germany. The size of the ovens is 37 ft. long, 19 ft. wide and 10 ft. high, each charge being 12.75 tons of coal. The yield per oven is 76 per cent. or 9.69 coke per oven, the time required being 21 hours. The total capacity of the plant is 1100 tons per day of 24 hours, blast furnace coke, 505,000 tons coal per annum being required.

The coal used is gas coking coal from Cannelton, West Virginia. The company has acquired 6,000 acres of coal lands in West Virginia from the Cannelton Coal & Coke Co. and are now operating them.

One of the bi-products will be 27,000 tons of tar per year, to be used by the Dominion Tar & Chemical Co. The 5400 tons sulphate of ammonia per year will be sold in the general markets and the 7,500,000 ft. surplus gas



Crusher Plant and Shafts, Helen Mine, Michipicoten.



Helen Mine, Michipicoten. The Mines are Connected by Railway with Michipicoten Harbor on Lake Superior, a Distance of $11\frac{1}{2}$ Miles.
About 3,500 tons are Loaded Into the Boats in two Hours.

per 24 hours will be used in the Steel Plant for heating furnaces, soaking pits and fuel. The coke from these ovens will be used direct in the blast furnaces of the Algoma Steel Co. and handled in special cars by electric locomotives to the blast furnace tracks.

New Dock.

A coal dock of 900 ft. is under construction and it will be equipped with two unloading machines with a capacity of 600 tons of coal per hour from vessels. The total coal to be handled over this dock during season of navigation, May 1 to Nov. 30, is 650,000 tons. The coal storage is 1,400 ft. by 300 ft. for

The commercial dock is used by the Algoma Central Ry. for handling all classes of commercial business, including coal for outside industries and different commodities from package freight boats.

Blast Furnaces.

Blast furnaces Nos. 1 and 2 of the Algoma Steel Co. have a capacity of 250 tons per day. The stacks are 80 ft. high and 10 ft. 6 in. in hearth. They are now producing Bessemer Iron which is taken direct to the Bessemer Converter and used in the form of hot metal. There are four steam blowing engines with 44 in. steam cylinders and 74 in. blowing tubs. These engines are

each, total horse power in building being 17,600. Four of these engines have blowing tubs for blowing the three blast furnaces, and the other four are direct connected with 1,500 k.w. generators for supplying electric power to the new Merchant Mills, docks, and for the Blooming Mill motor.

Open Hearth Department.

Three 40-ton open hearth steel furnaces are in operation, producing 280 tons steel per day. Three additional furnaces of same capacity are under construction and will be in operation early next year.

These furnaces are charged with basic pig iron and scrap which is converted

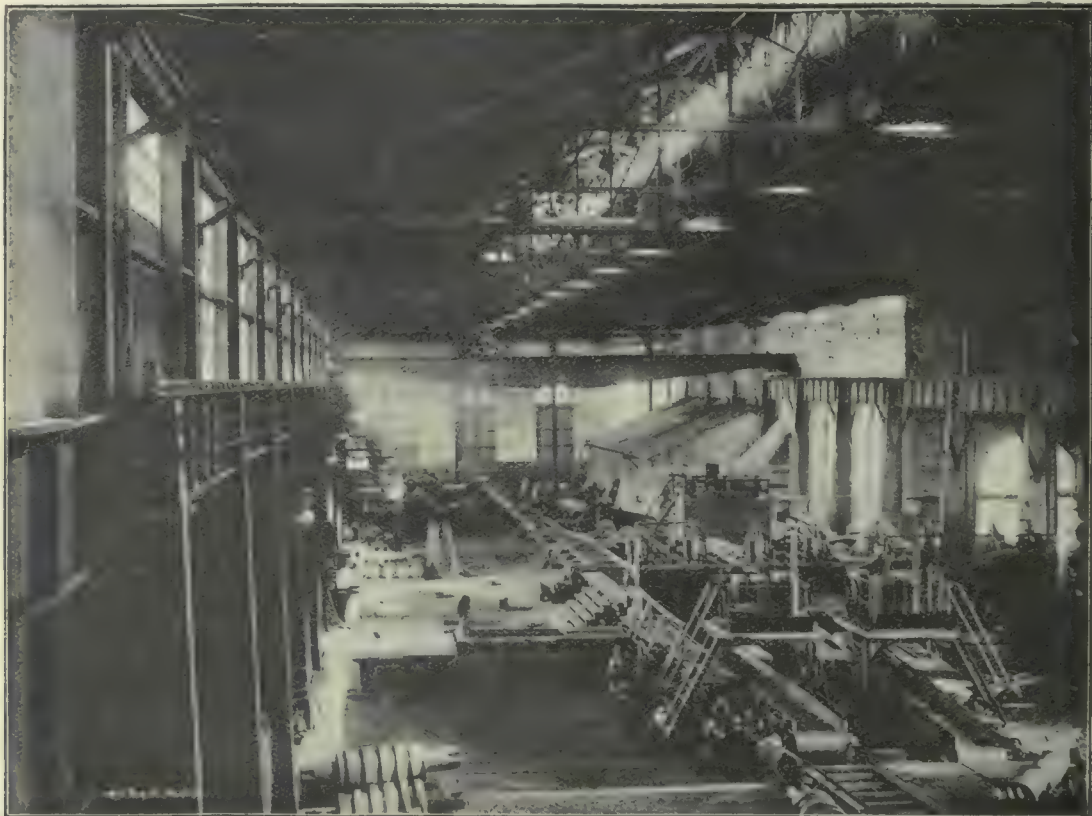

Interior of Rail Mill, Lake Superior Corporation, Sault Ste. Marie.

storage of winter supply of coal for coke ovens.

The rail dock, for loading rails and steel products into vessels for water shipment, is 450 feet.

The old ore dock is 900 ft. To this is being added 705 ft. making a total of 1605 ft. It is equipped with three ore bridges with 4-ton buckets, handling ore from vessels to docks and from docks to furnaces, the ore handled per year being 650,000 tons.

The total dock frontage is 2,955 ft., all deep water admitting the largest freight boats. Most of the ore and rails and a large portion of the coal is handled by the company's boats. All the docks employ 250 men.

to be replaced by the gas blowing engines now under construction.

The new blast furnace No. 3 will have a capacity of 450 tons per day with a stack 96 ft. high. The three blast furnaces will employ 250 men.

Gas Washing Plant.

Under construction is a plant for washing blast furnace gas by scrubbing with water to purify the gas for use in gas engines. In this connection a new pumping plant for water supply is being put in with a capacity of 30,000,000 gallons of water in 24 hours.

Gas Engine Power Plant.

The gas engine power plant has eight Allis-Chalmers gas engines of 2200 h.p.

into steel by high heat secured from the use of producer gas. The heat in these furnaces average about eight hours. Steel is poured into ingots and taken to soaking pits.

Bessemer Department.

Two 4-ton converters make from 175 to 200 heats per day. The average is 800 tons Bessemer steel in 24 hours. In these converters the hot iron from the blast furnaces, is used and converted into steel by the blast. These heats average about nine minutes and the steel is determined by color test. The steel is poured into ingots and taken to soaking pits to get uniform heat before rolling.

Bessemer and Open Hearth Blooming Mill.

The steel ingots are taken from soaking pits and are rolled into blooms with 18 passes. The capacity of the mill is 1,200 tons per day. A 4,000 k.w., d.c. motor is being installed to operate this mill. The motor equipment will be in operation in Jan., 1911.

The blooms are cut at shears in lengths according to the weight of rail to be rolled. The blooms are then placed in reheating furnaces by electric charging machines to get even heat in the steel before rolling into rails.

The blooms are taken from heating furnaces and carried to rail mill by tables and passed through three stands of rolls, 11 passes in all to finished rail. The sections rolled are 56 to 100 lbs. per yard. Hot saw cuts rail to length 33 ft. before passing to cooling beds.

Rails after cooling are straightened, drilled, and loaded on cars. They are all tested to see that the section is perfect and not over $\frac{1}{4}$ -in. variation allowed in lengths. Part of the product is shipped out by rail and part taken to docks on cars and loaded on vessels for shipment. The total number of men employed in the steel plant is 1,500.

The Merchant Mills include one 18 in. mill and one 12 in. mill. The product will consist of all shapes and sizes of steel from $\frac{3}{8}$ in. rounds to 8 in. beams and channels and 6 in. angles, also spikes, bolts and nuts, all railway fastenings and tie plates. The 18-in. mill will be operated with a 1,500 h.p. motor and the 12 in. by a 900 h.p. motor. Tables will all be electrically operated. This plant will give employment to 200 men.

The foundry produces 20 tons iron castings per day. The machine shops are equipped for both heavy and light work, and does work for outside companies in addition to repair work and renewals for the different subsidiary companies. They employ 150 men.

The Sault Ste. Marie Pulp & Paper Co. produce 100 tons pulp per day from spruce wood cut in the company's wood operations. Water power is used by vertical turbines connected with pulp grinders. Steam dryers produce pulp 98 per cent. dry. About 150 men are employed.

Water power is used by the Lake Superior Power Co., through six penstocks to generate electric power for street railways. Tagona Water & Light Co., city use and power for different industries.

Other Interests.

In addition to these industries at Sault Ste. Marie, the Corporation owns and operates the International Transit

Co. with $3\frac{1}{2}$ miles of track and 8-minute service electric cars; also the ferry between the two Soo's, having two large ferry boats, and the Trans-St. Marie's Traction Co. at Sault Ste. Marie. Mich., with 7 miles of track.

The Algoma Commercial Co. owns and operates car shops located on the line of the Algoma Central Railway with modern car manufacturing machinery, and an output capacity of 5 cars per day.

All industries at Sault Ste. Marie are located on the tracks of the Terminal Railway, which is owned and operated by the Algoma Central Railway.

The Algoma Central Railway is now operating 70 miles north of Sault Ste. Marie, and has 26 miles in operation from Michipicoten Harbor north, with 140 miles under construction, which will be completed by the latter part of 1911 giving a connection through from Sault Ste. Marie and Michipicoten to the Canadian Pacific.

The company owns and operates the Helen Iron Mine, located on the Algoma Central Railway, 11 miles north of Michipicoten Harbor, which produces 200,000 tons of high grade iron ore per year, and started shipping this year at the rate of 50,000 tons of 44 p.c. sulphur iron pyrites. This is the largest producing iron mine in Canada. The ore is all hauled to a modern dock at Michipicoten Harbor, having twelve loading pockets, and capacity of handling 1,000 tons of ore per hour from cars to vessel. In addition to Helen Mine, in this territory the company is now opening up the Maggie Mine, which has been proven by drilling to be a very large deposit of Bessemer ore. A large force of prospectors and six diamond drills are kept at work constantly in prospecting and testing iron properties.

PETRIE LEVEL.

The accompanying illustration is a full size reproduction of a level that is being sent to those interested by the H. W. Petrie Co., Front St., Toronto. It is a very useful instrument and is



H. W. Petrie Level.

accurate in construction. Readers of Canadian Machinery, writing to H. W. Petrie on their company's letterhead and mentioning Canadian Machinery, will be supplied with one of these useful levels gratis.

C. P. R. OFFICIALS' CONVENTION.

Matters of importance pertaining to the welfare of the C.P.R., the discussions being principally in connection with motive power and rolling stock, was the business discussed by the leading officials of the mechanical department of that company at the fourth annual convention which was held in Fort William recently.

Fifteen officials, including superintendents of locomotive power, master mechanics, assistant master mechanics, superintendents of shops and mechanical engineers, representing the C. P. R. system from coast to coast attended. The convention is held in Fort William annually the second week in November and at Montreal early in the spring.

New ideas as to the construction of locomotives for speed and safety, and also for the construction of passenger coaches, for the maximum of comfort are discussed. Those attending the convention in Fort William are H. H. Vaughan, of Montreal, assistant to the vice-president, who is the chairman; C. H. Temple, of Winnipeg, assistant superintendent of motive power on western lines; L. R. Johnston, Montreal, assistant superintendent of motive power on eastern lines; J. B. Elliott, Montreal, master mechanic of the eastern division; C. R. Ord, Me-Adam, master mechanic of the Atlantic division; J. Mills, Toronto, master mechanic of the Ontario division; A. Dixon, Toronto, superintendent of shops; G. Reid, North Bay, master mechanic of the Lake Superior division; R. Preston, Winnipeg, master mechanic of the Manitoba division; W. Woodhouse, Winnipeg, superintendent of shops; J. Frith, Winnipeg, mechanical engineer; G. Evans, Montreal, mechanical engineer; S. Phipps, Vancouver, master mechanic of the Pacific division; R. Pyne, Calgary, master mechanic; A. T. Short, Moose Jaw, master mechanic of Saskatchewan division.

PNEUMATIC TOOLHOLDER.

On page 48 of the November issue of Canadian Machinery is a description of a pneumatic toolholder used on Bertram

wheel lathes. This clamp was designed by W. Peterson of the C.P.R. shops, Montreal, who has taken out Canadian and United States patents. This patent, No. 128267, has been assigned to John Bertram & Sons Co., Dundas.

MACHINE SHOP METHODS ^A_N^D DEVICES

Unique Ways of Doing Things in the Machine Shop. Readers' Opinions Concerning Shop Practice. Data for Machinists. Contributions paid for.

PITCH OF PROPELLERS.

By H. J. McCaslin.

It occurred to the writer, after reading with much interest Mr. Cleaton's article, Practical Method of Obtaining Pitch of Propellers, appearing on page 45, November issue of Canadian Machinery, that he, as well as other readers of your publication might, perhaps, be interested in a simple and inexpensive device employed extensively along the Great Lakes.

The outfit is shown in Fig. 1, and con-

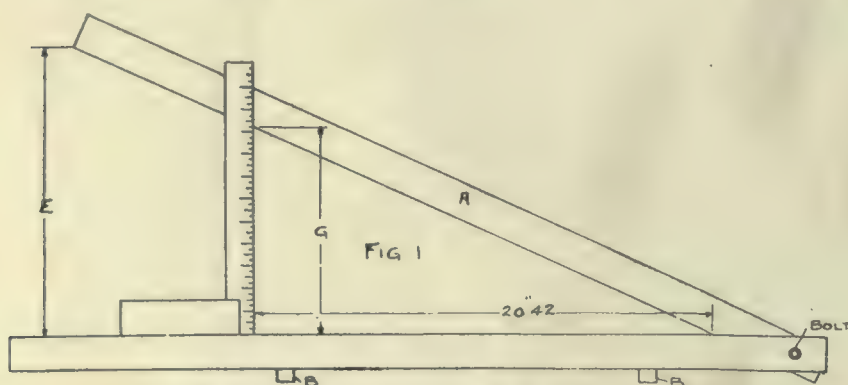

Fig. 1.—Measuring Pitch of Propellor.

sists of 3 in. parallel pieces about 36 in. long, 2 in. wide and $\frac{3}{4}$ in. thick, and 2 little blocks about $\frac{3}{4}$ in. square. Two of the pieces are fastened together with a bolt or screw, in the form of an angle, as shown, this arrangement permitting the adjustment of the leg A while try-

To obtain this variation, the distance E can be measured after each adjustment of the angle to the various blades, and then the leg A set midway between the two extremes for making the calculations.

The distance F which is the horizontal

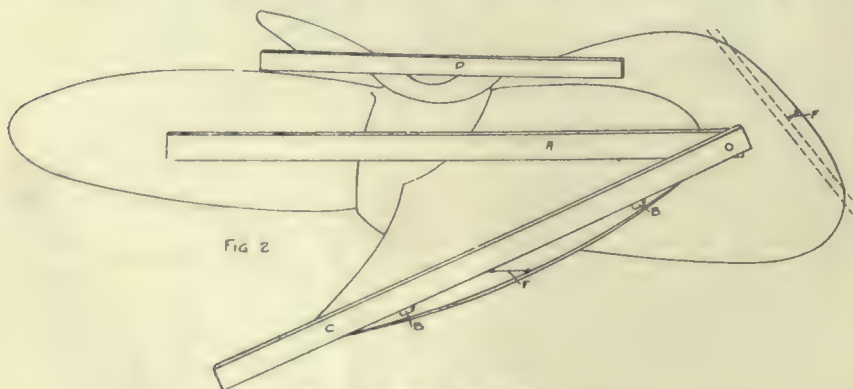

Fig. 2.—Pitch of Propellor.

ing for the angle of pitch. The two little $\frac{3}{4}$ in. square blocks B are bradded to the lower leg C in about the position shown, and are intended for bearing joints, as the edge of this leg would not rest evenly upon the curved surface of the blade. Fig. 2 shows the manner in which the device is applied. The piece D is placed across the hub parallel with the angle which is set near the tip of the blade. Now by sighting over the upper

edge of the leg A of the angle, the leg is adjusted until it lies in the same plane as that of the upper edge of the piece D. This operation is identical to sighting over two parallels to detect the wind or twist in a board or surface, only in this case the leg of the angle is adjusted to suite the variation. Distortion is very apt to appear in the different blades of a propeller and it is advisable to try each one and then take the different average of any difference, which may be found.

upon which the pitch is taken would be 6 feet 6 inches and this diameter would have a circumferential length of 20.42 feet. Now by applying the scale of 1 inch=1 foot, we lay off 20.42 inches upon the upper edge of the lower leg of angle as shown in Fig. 1 and apply a square as shown, and measure the perpendicular distance G. This distance G is equivalent to the pitch of the propeller to a 1 inch=1 foot scale and it would be $9\frac{1}{4}$ inches in this instance which would be equal to 9 foot 3 inches, the pitch of the propeller.

The reason for the above method arises from the fact that a true screw or helix is formed by a right angle triangle wrapped around a cylinder, the base of said triangle will equal the circumference of the screw, the perpendicular will equal the pitch, and the hypotenuse will equal the length of the winding thread or helix.

MACHINING WATER WHEEL GATES.

It is principally with the boring of the pivot holes shown at A, Figs. 1 and 2, that this article has to deal, rather than with the general machining of the gates.

Consider first the small gate shown in Fig. 1. It measures 11 ins. from tip to tip, and is 12 ins. in width, with two 3 in. bosses B, one on either edge of the gate. The core of hole A is often off centre. Preliminary to boring this hole, the two sides are planed the proper width. Then, for the boring operation, an angle plate is bolted to the face plate of the lathe, the proper distance off centre, so that when the gate is resting at points C and D, the centre of hole A is in line with the lathe centre. Alignment in the other direction is quickly made by bringing the outer edge at D, up to a line previously marked on the angle plate. The gate is then forced against the face plate on its finished edge, and bolted there, and the one boss bored with a small inside boring tool, and reamed, in that position. The other boss, which must be aligned perfectly with this first one before being bored, has this feature expeditiously done, by putting a centre in the lathe head, with a shank the size of the reamed finished hole. This aligns the gate perfectly by shoving up into position, when the boring and reaming operations are repeated.

The larger gate shown in Fig. 2, presents more interesting operations. Its dimensions are 21 ins. from tip to tip, and 25 ins. wide, with the boss B pass-

distance between the angle and tip of blade is next measured and we are ready to calculate the pitch of the propeller. For an example, let it be assumed that the propeller to be measured is 6 feet 8 inches diameter with a pitch of 9 feet 3 inches, the latter dimension, of course, being the one to be found. Since the propeller is 6 feet 8 inches diameter and the angle is placed 1 inch from the tip of the blade as shown at F, the diameter

ing from side to side, with the exception of a 1 3/8 in. cut-out at the centre. This cut-out is the ending place of the machining operations from each side. As before, the sides are planed parallel. The gate is then bolted onto the lathe carriage, the whole being shoved up against the face plate first for squaring up. The bottom is jacked up to give the



Fig. 1.—Small Water Wheel Gate.

proper alignment. Now the difficulty is to have the two parts of the cross boss B bored perfectly in line, and the operation would be very difficult unless the whole operation were done at one setting, as re-setting perfectly correctly would be difficult. For the purpose of boring completely at one setting, a special boring bar is employed, of the shell reamer type. Now, if the whole operation had been done right through, a bar twice the width of the gate would be required, with the reamer at the centre of this bar, the whole suspended between lathe centres. If the whole is cored off centre, this will make the bar chatter, and ream the hole incorrectly. This is overcome in the following manner: A shorter bar is used, with the reamer quite near one end—just far enough in that it will completely bore one end of the divided boss. As the reamer is near either centre, it is quite solid. When one end is completed, the whole bar is removed, and placed in the machine, end for end, and the direction of rotation of the lathe reversed. This completes the other half of the boss, the

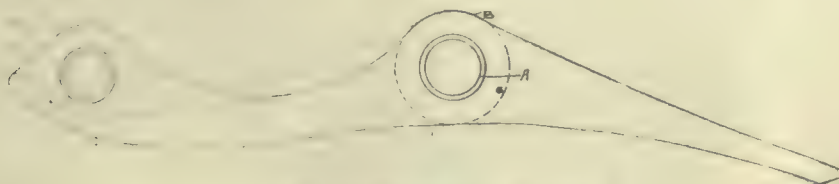

Fig. 2.—Large Water Wheel Gate.

cutter being held rigidly. By these means, a perfectly true hole is expeditiously made.

AUTOMATICALLY MACHINING BLOWER IMPELLERS.

The illustration shows an attachment recently built by the Rockford Machine Tool Company, Rockford, Illinois, for one of their customers, to be used in connection with a 16" Rockford shaper, for automatically machining the impellers for exhausters used with vacuum cleaning machines. A finished part is shown on the base of the shaper, and

an impeller will also be seen in the machine set up ready for operation.

The fixture will be understood by referring to the cut, and consists of a head bearing, carrying a hollow spindle with work driver and masterplate on the

irregular parts without sharp corners and will reproduce any shape that can be rotated against the roller.

TURNING LONG BARS.

It quite frequently happens, in a small shop that a long bar must be turned—

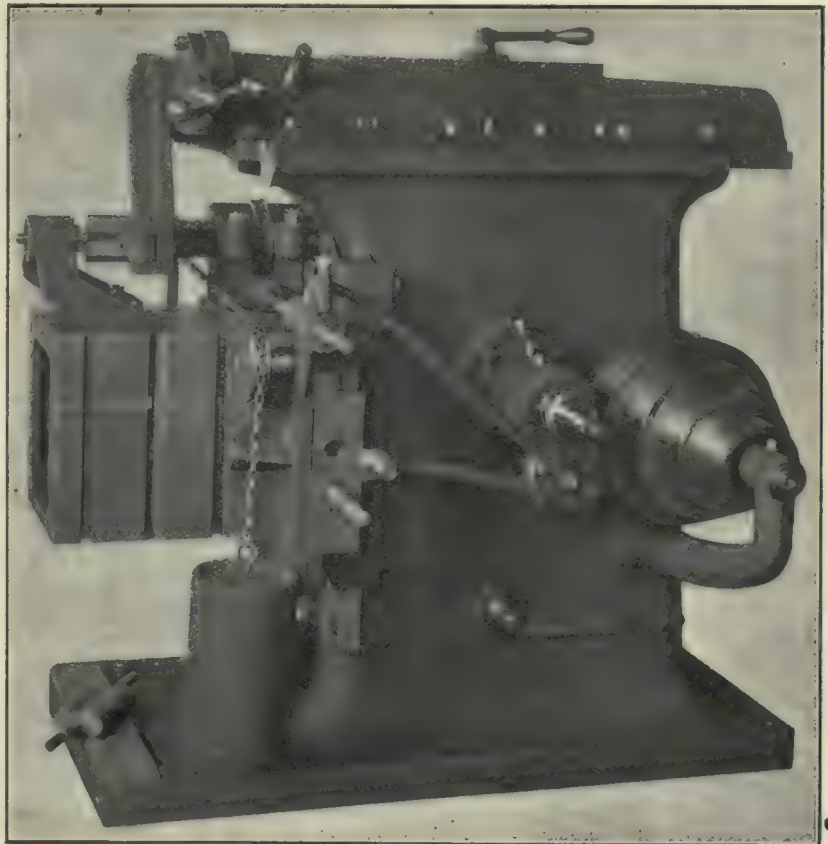

Attachment on 16" Shaper for Automatically Machining Blower Impellers.

inner end, which is of the exact form of the work to be produced. The crossfeed screw of the machine is removed, leaving the saddle with work table free to move on the cross rail slide. The master

a bar often too long for any lathe in the shop to handle. To send it to some larger shop would involve considerable extra expense which perhaps would not be warranted.

Wm. Kennedy & Sons, Owen Sound, overcome this difficulty very simply. They had in their shops two long, low-swing lathes, neither one of which is long enough to handle some of their work. They have found it convenient for that reason, to place these two lathes end for end, aligning them correctly, in every plane, so that the tool of one lathe can take up the work where the other lathe leaves off, continuing the work, and doing it as perfectly as in a large lathe, capable of handling such large work.

DRILLING PROPELLER BLADES.

This device, used by Wm. Kennedy & Sons, Owen Sound, while designed especially for drilling the bolt holes in the hubs of propeller blades, may be applied to such an operation on any piece that has lathe centres.

The post shown is bolted to the drill base table, and has dowels in it to insure the exactness of its location when

cam is held against the roller by the weight and the worm is fitted with a sliding key to the feed shaft, allowing the table to move back and forth as the work rotates. The stud carrying the roller is mounted on a casting which is clamped in a fixed position to the vertical slide of the shaper column. The cutting tool used is round and of the same diameter as the roller. The fixture has been found to be very satisfactory, finishing the impellers very rapidly and with a very high degree of accuracy. It will be seen that it can be used for machining cams, or other

being re-set. The movable arm is keyed, allowing only of vertical motion. In the drill table is screwed a stationary

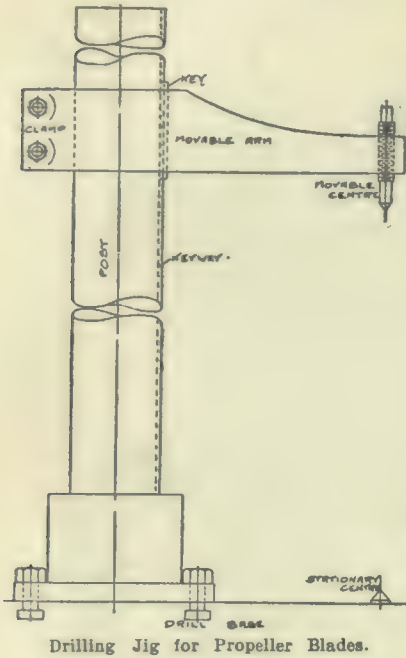

As before mentioned, this may be used for any piece having centres. Another use to which it is put is to make it serve the purpose of a clamp. The stationary centre is removed, and the movable centre screwed down on the article to be held, clamping it to the drill table securely.

In the form shown, it will take propeller blades up to three feet long. For larger sizes, it can be moved to a new location on the drill table overhanging the pit, in which is another stationary centre, directly below this new location of the post. Long blades can be handled by these means.

TO REMOVE RUST.

By E. Lambert.

Numerous methods of removing rust are in use, some of them good and others of little value. One remedy, both simple and effective, is a mixture of machine oil and emery powder. The use of coal oil is apt to do more harm than good as a rust eradicator: it removes but the rough top coating and glosses over where the process of erosion has begun.

JIG FOR IRREGULAR TURNING.

By J.H.R., Hamilton.

The accompanying sketch shows an attachment to be used on a lathe for turning or boring sections of circles where it is impossible to use a continuous cut, as the slots in cam plates or circular parts in irregular work, and other similar work.

Fig. 1 shows a front elevation of the attachment and Fig. 2 an end view of

the same. On the lathe face plate F is secured a crank plate C, the pin of which is removed from the centre of lathe spindle the required distance so as to give the stroke necessary for the surface being turned. Extending from the rear of the frame of the jig J is the arm A which carried the bell-crank B and also a quadrant on the side which carries a train of gears, to be used when the surface being turned exceeds about one-third of the circumference. The jig spindle is threaded on the end S, similar to the lathe spindle to receive the chuck or face plates belonging to the lathe. To operate, place the jig on the lathe shears and secure in position by the bolt B. Loosen the nut N on jig spindle and remove pin P allowing the spindle to revolve free. Secure the work W in the desired position in the ordinary way, and determine the stroke necessary for the desired operation. The collar O has a number of holes around its face to allow for adjustment; the pin P is placed in the nearest hole and further adjustment is made by lengthening or shortening the connecting rods, or shifting the crank plate C. Where the surface exceeds about one-third of the circumference, the train of gears can be used giving the desired travel to the face plate on which the work is secured.

Fig. 3 shows a skeleton sketch of the motion when using the bell-crank B and crank lever L. A cam plate (cam being about 1-6 of a revolution) is shown in position on the face plate F. The heavy lines show the position of the movable

centre, directly below the adjustable centre in the movable arm. The article to be drilled is set on the lower centre, the drilling jig placed on the top of the hub, and clamped there, and the adjustable centre tightened down. The article, a propeller blade, is thus held perpendicularly on its centres, causing the hub to be horizontal. The radial drill arm can then be swung over, and the holes drilled.

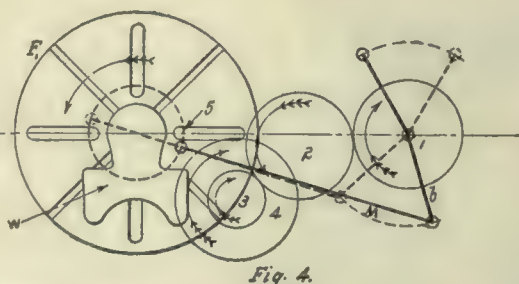
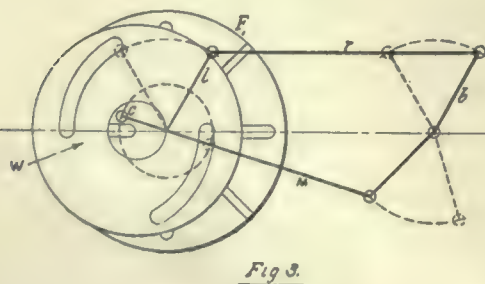
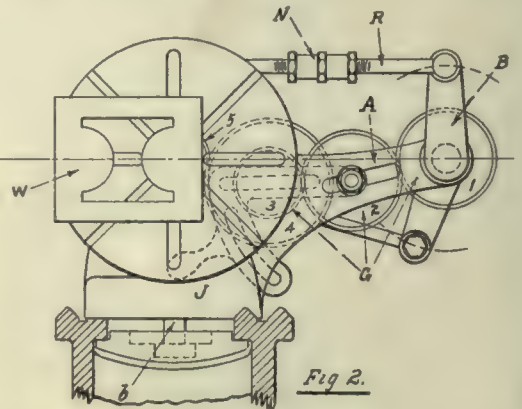
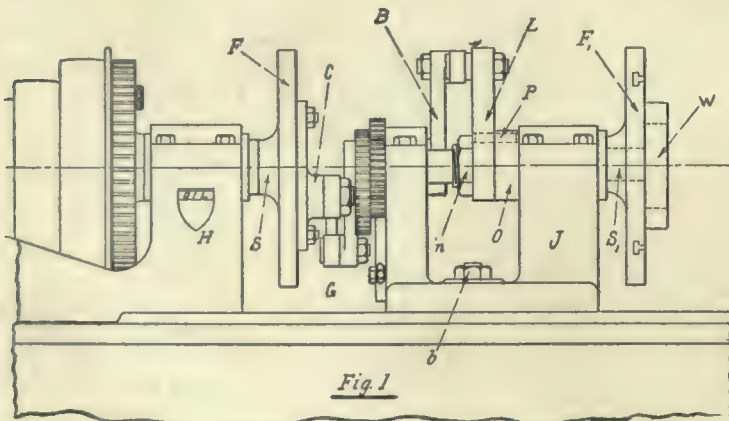

Jig for Irregular Turning.

parts at the beginning of the stroke, and the dotted lines show the other extreme position.

Fig. 4 shows a skeleton sketch of the motion when the train of gears are being used. The portion to be machined is (roughly figured) about 220 degrees of the circumference. With crank C in the former position the ratio of motion must be

$$\frac{220}{360} : \frac{1}{6} \text{ or } \frac{11}{18} : \frac{1}{6}$$

Take a 72 gear for jig spindle:

$$X = \text{gear on bell-crank}$$

$$\text{then } X : 72 :: \frac{11}{18} : \frac{1}{6}$$

$$\text{or } X = \frac{72 \times 11}{18 \times 6} = 264$$

There being no gear of 264 teeth, we must compound the train. Take 3 as a divider then:—

$264 \div 3 = 88$ for the gear on the bell-crank the compound gears 3 and 4 must be in the ratio of 1 : 3 or 30 : 90: then the gears necessary are:

- 1=88
- 2=any intermediate gear.
- 3=30.
- 4=90.
- 5=72.

$$\text{Proof: } \frac{88 \times 90}{30 \times 72} \text{ should equal } \frac{11}{6} \text{ or } \frac{11}{6}$$

$$\frac{88 \times 90}{30 \times 72} \times \frac{1}{6} \times \frac{18}{11} = 0$$

If the necessary gears are not obtainable, select the next nearest and adjust for stroke by shifting the crank C.

The pin P must be removed and nut N relieved when gears are being used; and quadrant lowered when lever L is being used.

WRENCH FOR WING NUTS.

By K. Campbell.

I was working in an agricultural shop at one time and one of my jobs in the early days was to put the caps on the oil boxes or bearings on disc harrows. These bearings were cast iron with chilled ball races. An oil reservoir kept the bearing lubricated. A little waste was put in the reservoir and the cap fastened on with a wing nut.

The screw often had scale on it or was rough from molding sand as it was placed in the mould and was thus fastened securely. The nuts had to be put on by hand and it was rather hard on the fingers. I often used to use a monkey wrench until one of the machinists told me of a wrench he had seen

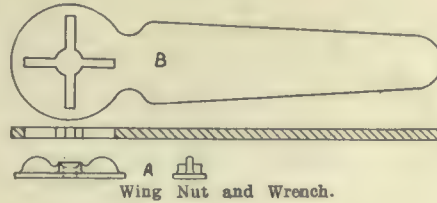

used for this purpose. I therefore made one, similar to that in the sketch, out of a piece of flat stock I picked up in the shop. The device worked excellently and I was able to screw on the wing nuts much quicker than before. In the illustration A shows the wing nut and B the wrench.

SIMPLE BROACHER.

The knitting machine made by the Harley-Kay Co., Georgetown, Ont., has

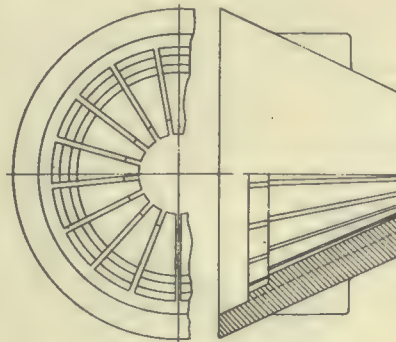

Fig. 1.—Knitting Machine Part.

a tapered part, shown in Fig. 1, which, as can be seen, is a conical shell, with slots on the inner surface in which the needles work. The simple machine shown in Fig. 2, which was devised and made by the firm, does the work very satisfactorily.

It is in reality a simple broacher, operating much the same as the standard machine. A is the broaching bar with cutter inserted in its lower face. This is given motion from the crank to the left, and is guided as shown. The work is held in the part B, which may be adjusted about pin C, and tightened in that position by Bolt D. Thus any taper can be slotted. Up and down motion is provided for by the part E, which can slide up and down in ways, and is adjusted by set screws at the top. The work is held in this chuck by the collar F, screwed down on it. Collar G has radial holes, evenly spaced, each collar containing three sets. A pin attached to E engages in these holes successfully as desired. Having sets of these collars, any circular division can be made by the use of the proper collar. The collar shown has a 34 hole collar to give 17 slots in the piece being machined.

CRANE SIGNAL.

One of the difficulties of overhead cranes in machine shops is often the waste time signalling the crane operator. When a man wants the crane he waves his arms, shouts or whistles, disturbing other workmen, or walks along the shop to give instructions to the operator, wasting a great deal of time.

The Lodge & Shipley Machine Tool Co., Cincinnati, have a shop 680 feet long and to facilitate the handling of materials by their two overhead cranes, have installed a system of signal lamps. Switches are placed at convenient intervals along the sides of the centre bay, each controlling a red lamp hung from the ceiling directly over that portion of the floor. These lamps are all connected in parallel with the regular incandescent shop lighting system, although each is turned on and off by its own switch. When an erecting hand needs the crane he throws the switch nearest him, which lights the lamp over that portion of the floor. If not already engaged the crane operator runs at once to the spot. If his

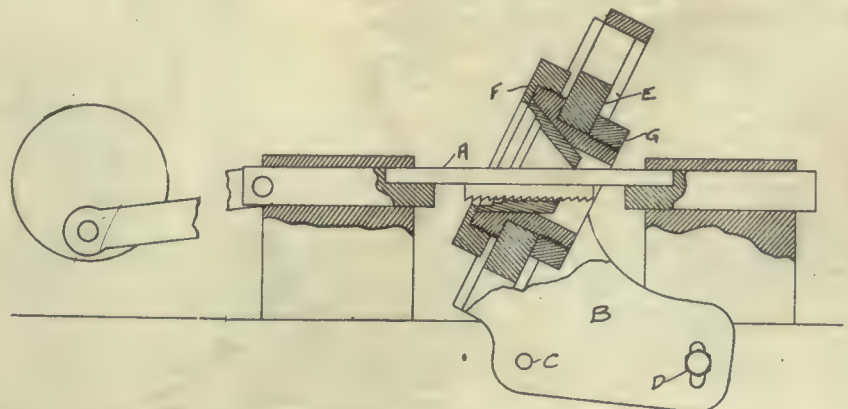
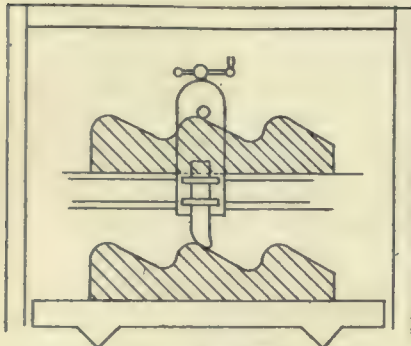

Fig. 2.—Broaching Machine for Slotting Knitting Machine Part.

crane is engaged at that moment he goes as soon as he is free. In either case the light remains burning until the crane reaches that point, when it is turned off.

PLANING SHAPES.

The accompanying illustration shows how a company planed a number of special plates for which it had a contract. The plates had to be absolutely accurate, and in order to machine them



Planing Shapes.

a jig plate was made from a $\frac{3}{8}$ inch sheet steel. This was fastened on the cross rail. They then ratcheted a slide in the head, and fitted a pin in it. As the head was fed across the job, the slide with the pin was fed up and down on the jig, making a particularly fine job.

60 IN. WHEEL VS. 18 IN. LATHE.

Some time ago, D. MacKenzie, Guelph, had the job presented to him of boring and facing the hub of a 60-in. flywheel. As he has nothing greater than a long 18-in. swing lathe in his shop he was in a quandary as to how to undertake the task, but finally overcame the difficulty in the following manner.

A long shaft was put in this lathe, just long enough to overhang at the end. At this far end, a pillar block was built up on the lathe, to support the shaft, it being thought that the steady-rest would not be sufficiently rigid for such a heavy job. The overhanging end of this shaft had previously been threaded to take the lathe chuck, which was then attached, and the flywheel chucked in this position. A small lathe from another part of the shop, and which was light enough to be portable, was brought up to the flywheel, and placed in line with the other lathe for boring the hub and then placed cross wise with the lathe for facing the hub. A good job resulted from this operation, and a trip to Galt saved, as the latter course would have been necessary otherwise.

REPAIRING LOCOMOTIVE BOILER.

By K. Campbell.

In round house practice and in boiler repair shops there are a number of special handy tools required to facilitate the work. In a paper read before a joint meeting of the British Institu-

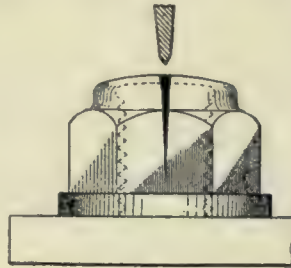

Fig. 1.—

tion and American Society of Mechanical Engineers, a paper was given in which a number of special tools were described.

To remove main steam pipes and steam chest covers from smokeboxes it is often necessary to split the nuts down vertically in the manner shown in Fig. 1, as they are apt to get "burnt" or corroded on the studs.

If the studs are broken, they will require to be drilled out carefully, and new studs put in, screwed to a tight fit. For removing and screwing in studs, a stud setter is an almost indispensable tool, though with skill and care two ordinary nuts tightly locked may be utilized for the purpose.

It is at times, when in a confined position, a difficult task to cut an iron nut from a stud without damaging the thread, and this often means the renewal of the stud. On the other hand, a few small screw die nuts of different sizes will assist in jobs of this description and are useful for running down studs and bolts which have been damaged or when they prove too tight a fit for new nuts. A good method of making die nuts is to get a square bar of good tool steel nicely softened and have it faced and cut off in a lathe to a suitable thickness. Four small holes are drilled to act as cutting edges, as shown in Fig. 2; but before drilling the

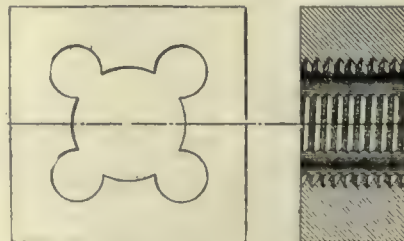

Fig. 2.—

larger centre hole to tapping size these smaller holes must be plugged with pieces of soft iron. The drill will then be enabled to run true, and the plugs

furthermore assist the tap to cut a good thread to the proper size. After tapping the thread, the soft iron plugs can be removed, and the cutting edges formed on the thread be finished off with a smooth file. These little appliances are almost indispensable in a round house or repair shop, for in taking off cylinder covers in a hurry, as often is needful, the stud threads are frequently damaged, and a die nut can be requisitioned to remedy the defect. Also, in taking down big-ends for examination it is a common occurrence to bulge the thread in knocking out the bolt; in such a case, a die nut is used to recut the thread before the nut can be replaced.

Drilling out broken studs on boiler mountings and fittings placed in a position not accessible for the ordinary ratchet brace drill post and tackle makes a demand upon the fitter for a special tool. In Fig. 3 is shown a small drill post that can be used to drill out broken studs ranging from $\frac{3}{8}$ -in. to $\frac{1}{2}$ -in. The foot of the post is well drilled out

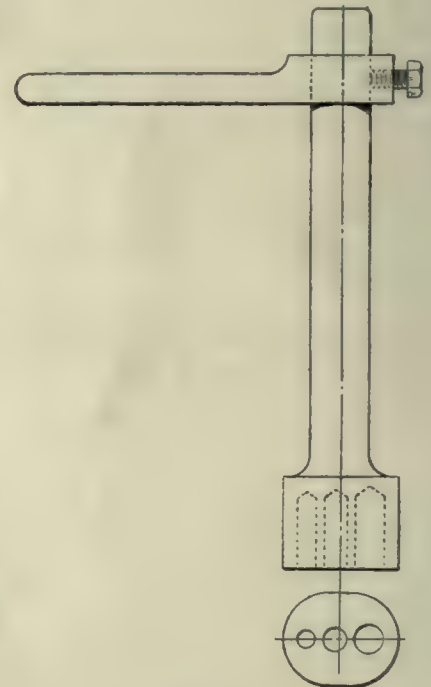

Fig. 3.—

to enable it to be attached to seatings where studs are standing $\frac{1}{4}$ -inch, $\frac{3}{8}$ -in. and $\frac{1}{2}$ -inch high on the boiler face plate, and the arm can be attached in any position to suit the convenience of the operator. A tool of this type has been found especially handy and useful in drilling out broken studs in Gresham's face-plate injectors, which are attached to face plates in a vertical position. One great advantage is the small space occupied by the base of the post; the appliance is also very light and suitable for packing in the fitter's tool bag.

DEVELOPMENTS IN MACHINERY

New Machinery for Machine Shop, Foundry, Pattern Shop, Planing Mill; New Engines, Boilers, Electrical Machinery, Transmission Devices.

POWER HACK SAW MACHINE.

The Massachusetts Saw Works, Chicopee, Mass., manufacturers of "Victor" hack saw blades, frames, machines, etc., have recently added to their line a new hack saw machine. This machine, which is illustrated herewith, is known as the No. 6 M.S.W. Hack Saw Machine. In the construction of this machine, each part has been made high grade in every particular—it is built like a machine tool, with a capacity for cutting 6 inch stock. It is unusually rigid and strong, the frame being braced from two directions, which elimin-



Power Hack Saw Machine.

ates all side play and vibration, and assures a straight cut.

An adjustable stop is provided so that cuts can be made to any desired depth. The machine stops automatically and does not require any attention after cut is started. There is also a rest for the piece being cut off, which



Fig. 3.

prevents the blades from getting broken, when the piece falls.

This machine has a very steady, even forward stroke, and a quick return stroke. There is a patent lift that can be adjusted to raise the blade 1-1000 to $\frac{1}{8}$ of an inch from the work on the return stroke, which saves wear on teeth and greatly increases the life of the blade, a feature which very soon results in a saving of hack saw blades sufficient to cover the cost of the machine.

BORING MILL AND LATHE TOOLS.

Figs. 1 and 2 show left and right hand tools for use on a boring mill. These tools have a shank $1\frac{1}{2}$ inches deep. The cutter in this tool is 1 inch triangular steel.

Figs. 3 and 4 show tools for general lathe and shaper work. The cutter is inserted in the centre of the holder and can be used either right or left, or the point ground to any shape the same as a square cutter. The V-shaped seat is a steel bushing pressed into the holder and can be renewed if it should become worn. This is to overcome the tendency of the constant pressure on the end of the cutter point to wear the seat down in the front end causing the cutters to break off.

The holders, including set screw and bushing, are made of tool steel, and hardened. These tool holders are manufactured by the G. R. Lang Co., Meadville, Pa.

FARWELL GEAR HOBBLER.

The Farwell Gear Hobbler, made by the Adams Co., Dubuque, Iowa, is designed for work up to 24 in. a cutting 12 in. face. The head has a long bearing upon the housing, the spindle has no unnecessary overhang, has adjustable bronze bearings of ample size and length, and is rigidly secured to the saddle. The compact and rigid design

of the spindle support has been a feature of the Farwell Gear Hobber.

On account of handling coarse pitches, this new tool is provided with a slide in the saddle that carries the hob, making

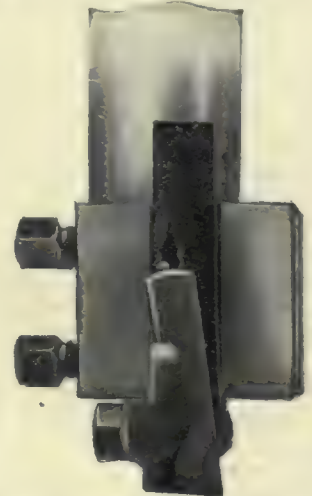

Fig. 1.—Left Hand Tool Holder.

it possible to adjust the hob spindle longitudinally, bringing any tooth exactly central with the work arbor. This

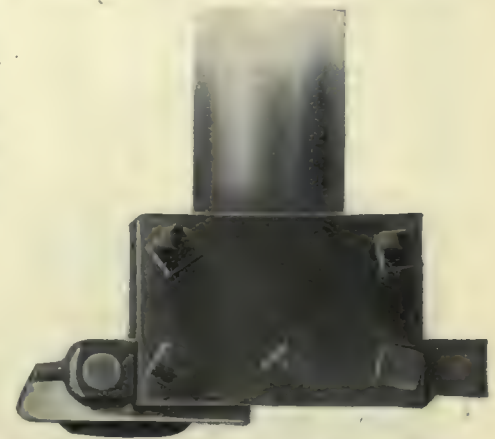

Fig. 2.—Right Hand Tool Holder for Boring Mills.

is quite important in obtaining perfect gears in coarse pitches, but does not require attention on fine pitches, as the difference in position of two succeeding teeth is not sufficient to be noticeable in the gears.

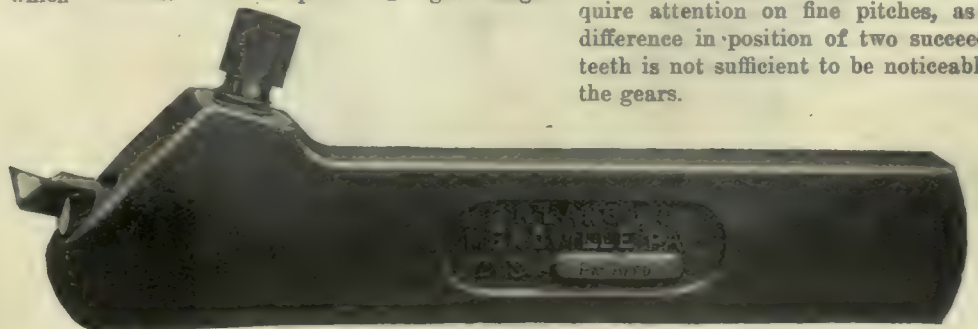

Fig. 4.—Lathe and Shaper Tool Holder.

This longitudinal movement of the spindle head permits also the shifting of the hob to a new cutting position without resorting to moving the hob or the arbor. Several shifts may be made, bringing sharp cutting parts of the hob into action before it is necessary to grind the hob.

The head has an automatic trip to stop the downward feed and is also equipped with a power mechanism for raising the head after the cut is finished. The head, of course, returns but once for each stack of gears, and on the small machine this operation is performed by hand. There are two extra feeds, making ten, all of which are obtained in the gear box. The horizontal feed mechanism for cutting worm wheels is incorporated in the design of the machine, and is also the special support for upper end of arbor. This arbor support is only necessary when gears must be swung on centres, for wide face gears or in cutting a stack of gears of small diameter. A more rigid support can be secured in other cases by the use of face plates or supporting rings which rest upon the table and support the blanks immediately below the rim.

The spindle is driven by a bevel gear, as this is necessitated by the coarser pitches tilting the hob to a greater angle than belt drive would allow. This angle and the tooth depth are set with a hardened steel gauge.

All important bearings have bronze bushings and the spindle and arbor bearings may be adjusted by simply loosening a lock ring and tightening an adjusting ring nut.

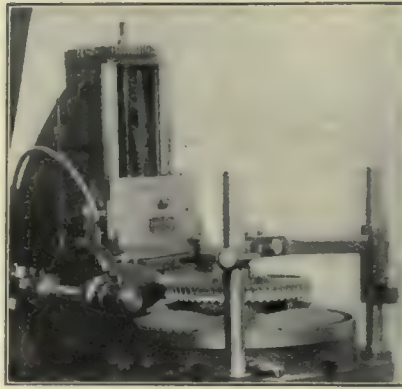

Farwell Gear Hobber, Cutting Worm Gear.



Farwell Gear Hobber Cutting Pinion.

The design of the base and column of this machine is exceptionally rigid, one casting forming both, as well as the knee below the table and an oil pan

around the machine. The weight of the machine is over 2,000 lbs.

A large tank to hold lubricant is enclosed in the base, and ample passages through the hub are provided to conduct the lubricant from the table back to the tank. The lubricant pump is gear driven and has means for regulating the flow of lubricant.

All gears are provided with shields, as is also the universal joint shaft.

PUNCHING AND REAMING BOILER PLATE.

At the recent annual convention of the American Boiler Manufacturers' Association held in Chicago, the following question was given for discussion:

"There seems to be a very wide range in engineers' ideas of what amount of metal is necessary to be taken out after a hole is punched in a plate. To remove all doubt as to the possibility of a fracture from that operation an answer to the following is suggested: Is a hole enlarged 1-8 or 1-16 in. all around sufficient? Is a hole enlarged $\frac{1}{4}$ or $\frac{1}{8}$ in. all around sufficient? Is a hole enlarged 3-8 or 3-16 in. all around sufficient?"

In answering the question John J. Main, of the Polson Iron Works, Toronto, referred to tests made in England some 18 or 20 years ago as to the difference between punching and reaming a hole or drilling it, which established that a $\frac{3}{4}$ in. hole would require to be punched $\frac{1}{2}$ in. in diameter in order to make it equal to a drilled hole, and a punched hole $\frac{3}{4}$ in. in diameter would not stand within 20 per cent. as much as a drilled hole; but in a reamed hole, taking out 1-8 in. all around would eliminate all the damaged part of the plate, and it would then stand just as good a physical test as the drilled hole would. Any practical man, however, will admit that it depends largely upon the condition of the punch and the die. These must be absolutely sharp and clean cutting.

BOUNTIES ON IRON AND STEEL.

The following companies participated in the bounties paid by the Dominion Government on iron and steel in the fiscal year ended March 31, 1910:

Algoma Steel Co.	\$ 318,814
Dominion Iron & Steel Co. ...	1,029,503
Nova Scotia Steel & Coal Co. ...	97,345
Hamilton Iron & Steel Co....	238,408
Lake Superior Iron & Steel Corporation ...	54,628
Ontario Iron & Steel Co.	4,463
Canada Iron Corporation	41,146
Atikokan Iron Co.	15,099
Standard Chemical Co.	10,120

Total bounties paid\$1,808,533

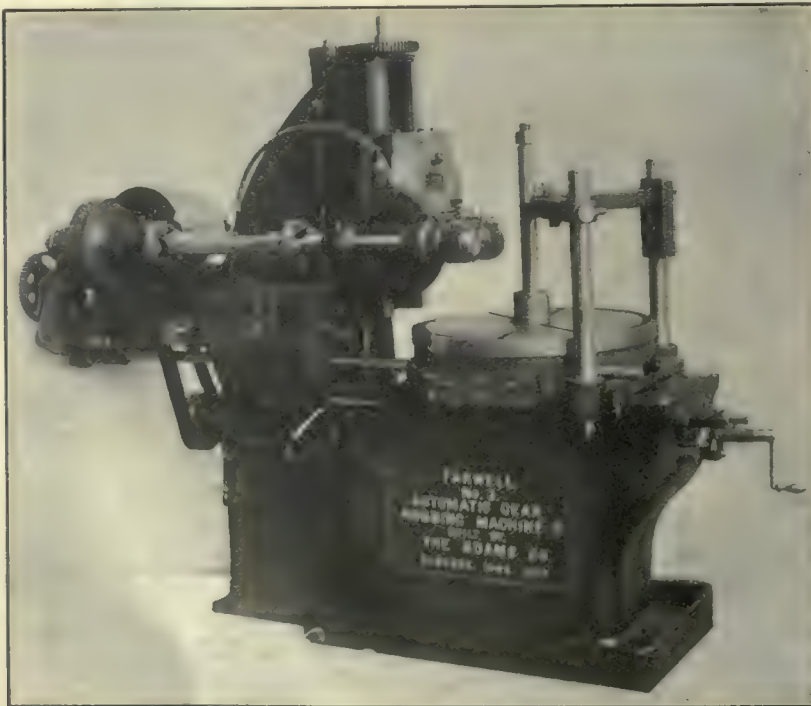

Farwell Gear Hobber.

POWER GENERATION ^A_N^D APPLICATION

For Manufacturers. Cost and Efficiency Articles Rather Than Technical.
Steam Power Plants ; Hydro Electric Development ; Producer Gas, Etc.

ONEIDA STEEL PULLEY

All-steel pulleys, made by Oneida Steel Pulley Co., Oneida, N.Y., with offices at 32-36 South Clinton St., Chicago, are being placed on the Canadian market. The pulleys are light, strong and serviceable. Their system of construction allows a great range of sizes and styles of steel pulleys. They make pulleys from 6-in. to 126-in. in diameter, with 2-in. to 40-in. face to fit any standard-size shaft from 1-in. to 8-in. in diameter. Besides the regular belt pulleys, they can make such specialties as conveyor drums, elevator, head, tail and tripper pulleys, flanged pulleys, cork insert pulleys, and flanged pulleys for axle dynamos, used in car lighting service.

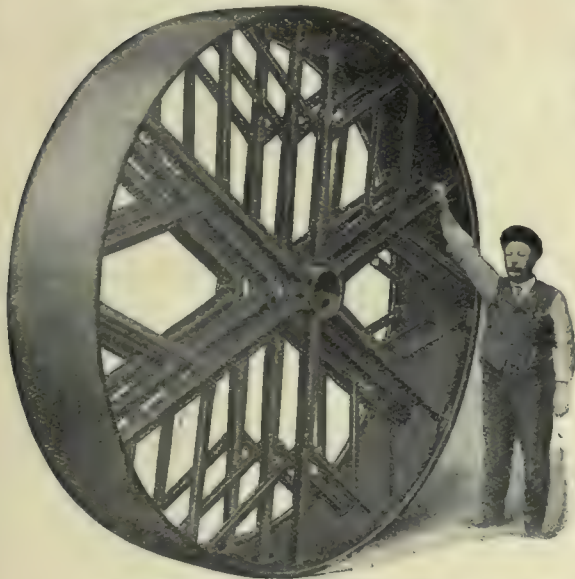

Showing the Construction of the "ONEIDA" With Spiders for Wide Faces.

The system of construction used by the Oneida Steel Pulley Co. is very unique—one of the most prominent features is the fish-plate system of arm to rim fastening, on pulleys above 20-in. in diameter. This fish-plate makes a broad bearing for the arm, and it answers the purpose of a double-thick rim with no superfluous weight.

They also insert extra sets of arms or spiders in wide-faced pulleys, to afford support across every 8 inches of the entire width of the pulleys—for instance, a pulley with a 24-in. face has three spiders, while a 40-in. face pulley has five spiders.

It is not necessary to use key-ways or set-screws to fasten the "Oneida" pulley to the shaft—the hub is so con-

structed that it grips the shaft securely without danger of slipping. A system of interchangeable cast iron bushing is also used. This allows the pulley to be used on several different sizes of shafting, by merely inserting the correct bushing.

The illustration shows the construction of the Oneida all-steel pulley, with spiders for wide faces.

IMPROVEMENT IN SLIDE RULE.

By Carl J. Printz.

The slide-rule is such an old reliable tool that few, in this busy day of ours, will care to read an article under that heading. The old saying that "Rome was not built in a day" applies here.

The heading of this article is not quite correct as the improvement is not in the rule itself, but in one of its fittings, that is on the so-called indicator or rider.

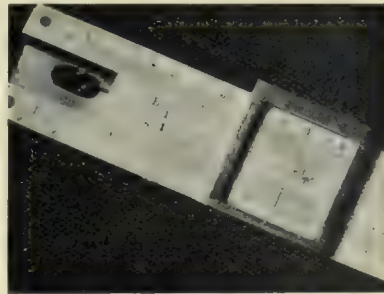

Fig. 1.—Old Style Indicator.

Fig. 1 shows the common indicator, consisting of an aluminum or brass frame, into which is fitted a glass plate with the indicator line. As the slide-rule seems to have a tendency for "flying" from the draughting board to the floor, the result is generally disastrous.

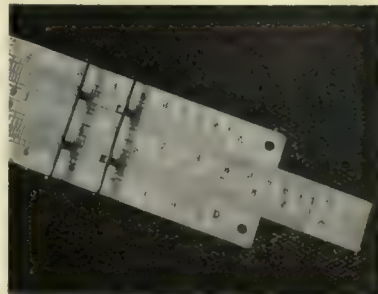

Fig. 2.—Improved Indicator.

This, however, is not the main objection to the glass-aluminum framed indicator. What bothers the user many times more, is the constant covering up

of the figures on the logarithmic scales by the wide frames.

Fig. 2 shows an improved indicator, patented in the United States, but which for certain reasons is not yet on the market. Any engineer in the habit of using a slide-rule, will readily see the advantages. There is no glass to break, and, on account of the wire framing being out from the graduations, the figures are always visible. The index lines are on the celluloid covered cross-bars, and a much closer reading can be made.

It is to be hoped that somebody will take up the manufacture of this article in the near future. It is not patented to break, and, on account of the will in Canada.

FINDING CENTRE OF CIRCLE.

By K. Campbell.

To find the centre of a circle, place a square on the circumference of the

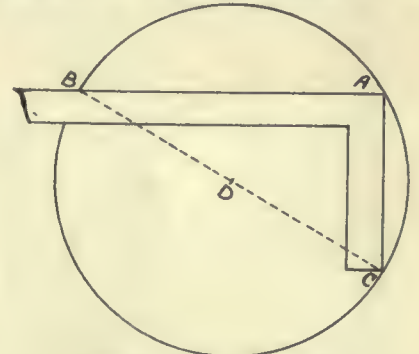

Finding Centre of Circle.

circle, as shown at A, B and C. Draw a line as the dotted line BC and bisect it at D. Then D is the centre of the circle.

REMOVING INK FROM TRACING LINEN.

Much difficulty in removing ink lines from tracing linen has been experienced from time to time by draftsmen and mechanical men generally. No instrument will satisfactorily remove them and no aqueous solution will remove the ink. In fact water in any form is harmful to tracing linen, as every draftsman knows to his sorrow.

If lines are to be removed from tracing linen, it can be done easily by rubbing the tracing linen with a cloth moistened with a solution of gum camphor in alcohol. This may not remove the lines altogether but they will be left so thin and faint that a slight application of a soft rubber will entirely erase them. This method does not harm the tracing linen to any extent.



FILING DATA.

By Jno. A. Bradley.

I have often read with much interest in various Trade and Technical papers, methods for keeping track of data, and reading matter appearing therein of special interest to the individual reader. A system which I have found to require the least labor to maintain and to show instantly where any article to

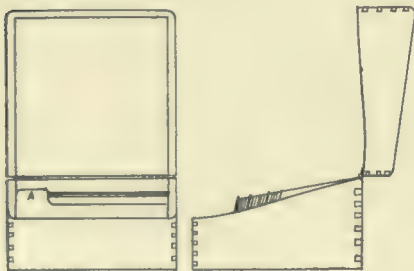

Fig. 1.—Filing Data.

which this system has been applied may be found, is as follows:

Obtain from any stationery store a card index box, measuring 5½ inches long by 3 inches wide, as shown in Fig. 1, containing cards and index.

When the paper for the current month is received, all the articles are read, or only those which are of interest. After having read an article, the heading under which it is desired to be entered in

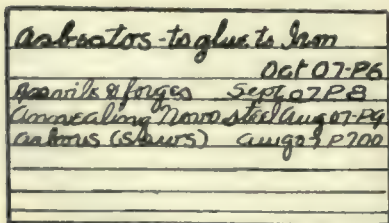

Fig. 2.—Filing Data.

the index, is written above the regular title, or the regular title may be entered depending upon the nature of the article.

The various headings are then entered under their regular or selected titles on the cards, giving the month, year and page in which the various articles appeared. See Fig. 2.

The paper is then filed according to the month, and when it is desired to

make use of any of these articles, or if you are seeking information upon a subject, the file will show instantly where it is to be found.

It will be found an excellent plan to have the papers bound, six or twelve to a binding, according to the size of the paper. This may be done from seventy cents per binding up. The necessity of preserving obsolete advertisements which form the greater part of most papers, is then eliminated, and these papers when bound make ornamental and valuable additions to the library.

SHOP BLACKBOARDS.

In the shops of Lodge & Shipley Machine Tool Co., Cincinnati, blackboards are used for posting shop order numbers for the information of the assembling force. There is a shop order number for every job entering the factory. A blackboard 18 x 24 in. in size is hung above each lathe which is in course of construction on the assembling floor, just as soon as the bed is placed for the first operation. On this board are chalked the size of the lathe, its order number, the special attachments, if any, and the completion date.

The data on the blackboard serves to keep prominently before each man the information necessary for his particular work. For example, those who align the headstocks know that they must complete their part of the work two weeks before the date chalked on the board. If a tool room lathe is to be fitted with a relieving attachment as an extra, it is plainly shown in black and white.

The same information is also given on the shop order tag which is wired to the lathe. The blackboard is merely an added convenience and timesaver, so that a workman, even if a few yards away, can get at a glance the important particulars of the job.

ORGANIZATION CHART.

By F. H. M.

Organization is the keynote of all modern business. To put it in the words of Mr. Barton, general manager of The Niagara Falls Power Co., and its allied interests, "We CONSIDER THAT ANY

COMPANY THAT IS NOT WELL ORGANIZED WILL SOONER OR LATER COME TO GRIEF; AND ANY ORGANIZATION SCHEME THAT CANNOT BE TABULATED IS NOT WORTH HAVING." The company indeed carries out this principle, the accompanying diagram being the tabulated scheme of their organization.

Under the one management are four companies, The Niagara Falls Power Co., Canadian Niagara Power Co., Niagara Junction Railway Co., and the Niagara Development Co. The diagram as shown is practically self-explanatory. Following the diagram down from the Board of Directors, Vice-President, the authority for each of the minor satellites is shown. Under the general manager, come the production department.

The greatest part of the combination includes the power houses, of which there are two: one on either side of the line, both under the one superintendent, who has an assistant at each plant. Each assistant has his own staff of operators, as shown. An apparent overlapping of authority occurs in connection with the electrical and mechanical assistants to the superintendent. These two men report to the assistant superintendents, thus introducing double authority apparently, but, as the assistant superintendents are in daily consultation with the superintendent, this overlapping does not actually exist. A similar condition exists with regard to the chief lineman and his staff.

Another feature of the diagram stands out as worthy of note. After most of the names appear numbers. In connection with the chiefs, these numbers have reference to the number in the staff under that particular official, e.g. the general manager has a staff of 293. The numbers following the workmen have reference to the number of that kind of workmen there are, e.g. looking at the column at the lower left corner, there are three electricians in charge at Power House No. 1, six assistant electricians. The same follows out for the rest of the officials.

If every large company would follow out a scheme somewhat the same as this one shown, much confusion would be

The Scheduling of Locomotive Repair Work on the C.P.R.

The C. P. R. have Worked out a Method of Handling Engines in the Shops by Which the date of Delivery is at Once Known. The Routing System, Described in Industrial Engineering, Shows that the System Produces Results, Both in Efficiency and Financially. By it the Various Departments are Tied Together, the Work is Now Done Better and More Cheaply, for There is no Waste Time. There is a Decreased Overhead Expense on Each Engine, and an Estimated Saving of \$65,000 per Year.

THE Canadian Pacific Railway has adopted at its Angus shops in Montreal, a system of scheduling locomotive repairs, so that it can be definitely determined in advance just when an engine sent into the shop for repairs can be placed back in service. It has done more than this, for incidentally in scheduling the engine through the shop, it has eliminated friction between departments by squarely placing the responsibility for delays; it has definitely assigned to each department a task, to be done on a certain day, and has issued instructions as to how this task can best be performed in the shortest possible time; it has thereby reduced the cost of repairs; it has shortened the time that an engine is out of commission, thereby saving to the road the loss it would otherwise sustain due to the loss of the engine's services; in short, it has raised the efficiency of the entire plant a measurable degree.

Locomotive repairs are a perplexing problem on all railroads. The time that an engine is in the shop represents a dead loss to the road. While it is desirable to cut this time down to the lowest possible limit, it is yet necessary to make the repairs in such a manner that the intervals between trips to the shop shall be as long as possible. Consequently, any means which will enable the most complete overhauling to be done in the shortest time, is the most efficient. Due to the fact that many separate departments are involved in locomotive repairs, delays in putting the engine back on the road are liable to occur, and the responsibility cannot always be clearly placed. Inasmuch as the erecting shop must receive from the various departments, such as the boiler shop, foundry, machine shop, and stores, the various parts of the engine in a certain sequence, a delay in one department, which is required to have its part placed on the engine at an early date, will nullify all the good work of every other department, and may delay the completion of the engine for a considerable period. The Canadian Pacific suffered from these repair troubles like every other railroad, and a couple of years ago engaged the services of Mr. H. L. Gantt to supervise the reorganization of the Angus shops. This reorganization, while as yet un-

completed, has already progressed to a point where there is a marked improvement in the conduct of the locomotive department.

Routing the Work.

THE SYSTEM IN USE TIES TOGETHER ABSOLUTELY THE VARIOUS DEPARTMENTS CONCERNED. When an engine comes into the shop, it is known in advance what must be done on it, and the date on which it must be delivered back to the operating department. Before a stroke of work is done, every operation that must be gone through is determined, and not only that, but who shall have charge of that operation, and when it shall be completed. THE WORK IS LAID OUT SO THAT THE MAN RESPONSIBLE FOR THE SCHEDULING OF AN ENGINE THROUGH THE SHOP CAN TELL, LITERALLY, AT A GLANCE JUST WHERE EACH PIECE IS, WHEN IT WENT THERE, AND WHEN IT WILL BE DELIVERED TO THE ERECTING SHOP. He can also tell when each portion of the engine will be assembled, when it will be tested under steam, and when it will be delivered to the road for service. He can, almost instantly, tell when a piece is delayed in any department, and can take the steps to remedy the delay, such as a re-schedule, or whatever remedy is best suited to the needs of the case. He renders daily to the superintendent a report showing the condition of work in the shops, and that official is able from these reports, with a minimum of effort, to place responsibility where it belongs. All this has been accomplished with a comparatively small amount of clerical labor.

Delivery.

The entire scheme hinges on the date on which an engine must be delivered back to the road. Two classes of repairs are made, those involving a complete overhauling of the engine and scheduled to be made in 18 days, and those which are less complete, these being scheduled to require 14 days. It was found that, in order for the locomotive to be delivered to the road in the time specified, the erecting shop must receive the various parts, such as frames, boiler wheels, valve gear, etc., in just the sequence that they were needed, and just at the time they were needed. As

it requires time to make these various parts, it would not do to wait until the engine was stripped before ordering them. Consequently, the engine is carefully inspected in advance, and a full list of the repairs necessary is sent to the schedule clerk, whose duty it then is to order the new pieces required, and to advise the shops of the work they will have to do and when they will be required to deliver it.

There are, of course, many different blanks and forms involved, although these are less in number than might be expected. It would cause confusion, and would not particularly help the description of the system to take these forms up in detail and explain the particular function and arrangement of each. We will content ourselves with a discussion of the general principles of the system in use. The forms would, in any case, have to be varied to suit the conditions under which they might be used, but the principles will apply to similar work everywhere.

Let us assume therefore the the schedule clerk has received from the inspector the list of repairs necessary on a given engine. He also knows whether it is to have 18 or 14 days in the shop. This determines the final date of the schedule for that engine and all other dates are fixed to conform to it.

The schedule man classifies the repair operations according to the shops in which they are to be done. They are classified first in a general way, such as motion work, wheels, boiler work, etc.

The date on which each class of work is required by the erecting shop is noted opposite it, and the order is transmitted to the department concerned. In many cases it is only necessary to give the order for the part, and the date on which it is required. The job may be a standard one, with which the shop foreman is thoroughly familiar, and no further instructions are necessary. Other jobs, however, are more complicated, and require the services of several machines in the shop. The various machine jobs, perhaps, must be done in a certain sequence. In such cases the various operations are scheduled in detail for the benefit of the shop foreman. Take, for instance, a crosshead.

It must be planed, bored, babbitted, fitted and assembled, and inspected. The schedule man notes the day on which each of these jobs must be done in order that it will be ready when the erecting shop wants it. He does not endeavor to tell the shop foreman the particular machine to use, that being left to the judgment of the foreman.

The schedule clerk has in his office a large board, ruled into columns, and having 31 lines, one for each day of the month. Each column is headed with the name of a certain class of repair work, the classes being grouped together under the shop in which they are performed. When a job is scheduled for a given day, the engine number is entered on the line for that day, and in the column for the class of work to which the job belongs. Thus, by following along a given line, every piece of work due on that day is exhibited, and also the amount of work of each class that is scheduled. Knowing the capacity of the shop for each kind of work, the schedule clerk is enabled by means of this board to avoid overloading a department with one class of work on a given day and thereby throwing awry the schedule of other departments.

Schedule Sheet.

The sheet on which the detail schedule for each class of work is laid out, such as the motion schedule, is ruled in a similar manner to the schedule sheet above described—that is, with horizontal lines for each day, and with columns for each part to be furnished. When laying out the schedule, a symbol is entered in the proper space, to show the particular operation that shall be done on a given part on a given day. For instance, if a crosshead was to be babbitted on the 14th of the month, the letters Bb would be entered in red ink in the crosshead column on the 14th line. When the work is done the letters Bb are entered in black in the crosshead column and opposite the date on which the work is done. Thus, when a job is on time, the red and black symbols appear in the same space in the schedule sheet. It is thus easy, if a report on any engine is called for, to tell exactly where delays occurred, and of what duration they were.

Schedule Report.

Every day the schedule man makes out a typewritten report for the superintendent and shop foremen, showing the work scheduled to be completed on each engine during the day. To this list are added those jobs which were scheduled for previous days, but which are one or more days late. A letter X is placed opposite each of these delayed jobs, one X for each day that the job is delayed, together with the reason for

the delay. This has an effect on the various foremen not exactly contemplated at first, but which tends nevertheless to keep them up to schedule. A string of Xs after a job, together with the statement, say, "Waiting on castings," appearing day after day makes it apparent to every foreman in the shop that the foundry is holding up the locomotive, and incidentally delaying the work of all the other foremen. The constant reappearance of the statement until the piece is out of the shop, has a better effect in getting the piece rushed through than would the most severe "jacking-up" the superintendent could give. A man at fault dislikes exceeding publicity, but under the scheme in use in the Angus shops the greater the fault the greater the publicity. It further prevents placing responsibility for errors on the wrong man. The machine shop foreman is not censured when he does not deliver a certain part to the erecting shop on the scheduled date, if the report shows that the castings were not delivered to him when due. Instead, the censure is passed on to where it belongs, namely, the foundry.

While the principal work that has already been done at the Angus shops is the arranging of these schedules, a start has been made on a further systematizing of the work. To schedule the work through the machine and other departments with a knowledge that it will be finished at the time appointed, involves a knowledge of the time required for each operation and the certainty that the operation will be done in that time. This led to an investigation of the machine operations, with scientific time-studies, and the making of instruction cards embodying the results of these time-studies. The instruction cards are issued to the various foremen, and if they are unable to do the work in accordance with the time given in them, the man who made the time-study is ready to demonstrate to the foremen the exact method to follow in order to meet the schedule. These time-studies have resulted in standardizing many of the operations, and have materially cut down the time required for them. When a job is finally standardized, the instruction card is printed in a permanent form, with a sketch of the job on it. It is then used not only in the Angus shops, but in all the shops of the Canadian Pacific. The work, therefore, is larger than appears on the surface, since it affects not only one shop, but the entire system.

The by-products of the work which has been done are, in a measure, of as much importance as the work itself. The morale of the force has been improved to a great extent. The erecting shop foreman stated that his work was so

much lightened that he was able to give his entire attention to his men, and consequently to do better and quicker work. His attention was not distracted by the necessity of having continually to prod the other departments for material. The parts came to him in the order that he needed them and he was able to keep his men busy all the time on the work for which they were best fitted. In the other departments it was the same. The foremen know each day exactly what is expected of them. They are able to concentrate their entire attention on the work for that day, secure in the knowledge that the work of to-morrow is to be provided for them without any effort or worry on their part. The consequence is better and more accurate work.

Financial Benefit.

To the road itself, the benefit has been great. LEAVING ASIDE THE IMMENSE BENEFIT RESULTING FROM BEING ABLE TO KNOW WITH CERTAINTY THAT IT CAN HAVE ENGINES ON THE DAY PROMISED, THE FINANCIAL CONSIDERATION INVOLVED MAKES THE WORK DONE WELL WORTH WHILE. NOT ONLY IS THE WORK DONE BETTER AND MORE CHEAPLY. The road gains the services of the engines in a shorter time than was formerly possible, and the money end of this is no small item. There is in the erecting shop pit capacity for about 32 locomotives. The services of an engine may be valued to the road roughly at \$100 per day. If but a single day is saved in the time each locomotive is in the shop, the money represented amounts to \$3,200 each 18 days, or approximately \$65,000 per year, to say nothing of the decreased overhead expense on each engine.

It must be borne in mind as yet no attempt has been made to reorganize the shops so that they operate from start to finish on the principles of scientific management. This is a task which, in shops of the magnitude of the Angus shops, would consume a great deal of time. All that has been done is to even up the operating efficiency of the various departments so that they work together. The departments which before were run at a low efficiency have been improved so that they are now in harmony with the rest of the shop. The standard has been, heretofore, the most efficient department. When all have been brought to this standard, the next step will be to raise the efficiency of the shop as a whole. Although the work is far from complete, the results already achieved warrant the belief that in the end the Angus shops will represent the best practice in locomotive work to be found throughout the world.

CANADIAN MACHINERY

AND MANUFACTURING NEWS

A monthly newspaper devoted to machinery and manufacturing interests mechanical and electrical trades, the foundry, technical progress, construction and improvement, and to all uses of power developed from steam, gas, electricity, compressed air and water in Canada.

The MacLean Publishing Co., Limited

JOHN BAYNE MACLEAN, *President* W. L. EDMONDS, *Vice-President*
 H. V. TYRRELL, Toronto Business Manager
 G. C. KEITH, M.E., B.Sc., Toronto Managing Editor

OFFICES:

CANADA

MONTREAL Rooms 701-702 Eastern
Townships Bank Bldg

TORONTO 143-149 University Ave.
Phone Main 7324

WINNIPEG, 511 Union Bank Building
Phone 3728

BRITISH COLUMBIA - Vancouver
H. Hodgson,
Room 21, Hartney Chambers

GREAT BRITAIN

LONDON - 88 Fleet Street, E.C.
Phone Central 12960
E. J. Dodd

UNITED STATES

NEW YORK - R. B. Huestis
115 Broadway
Telephone 2282 Cortlandt

FRANCE

PARIS John F. Jones & Co.,
31bis, Faubourg Montmartre,
Paris, France

Cable Address:

Macpubco, Toronto. Atabek, London, Eng.

SUBSCRIPTION RATE.

Canada, United States, \$1.00. Great Britain, Australia and other colonies 4s. 6d., per year; other countries, \$1.50. Advertising rates on request.

Subscribers who are not receiving their paper regularly will confer a favor on us by letting us know. We should be notified at once of any change in address, giving both old and new.

Vol. VI.

December, 1910

No. 12

HIGH SPEED STEELS.

In this issue is an article on High Speed Steels by J. J. Duguid, general foreman of the G.T.R., Toronto. High speed steel has a cutting capacity which has led to carbon steel being entirely replaced by it in progressive machine shops. The introduction of it has resulted in a complete change in machine tool design, speeds and feeds have been changed and the machines made more rigid to withstand the heavy cuts possible with high speed steel tools.

Mr. Duguid gives a review of the progress made since the advent of high speed steel, but points out that greater results are possible. He states, "I believe more tools are ruined by careless grinding than by any other means." This can only mean that proper grinding methods should be followed if the full capacity of machine tools is to be obtained. To overcome the difficulty the tools should be ground on wet wheels and automatic grinders for heavy grinding. The pressure on the wheel is then kept uniform, the shape of the tools is kept uniform and much better results are obtained turning out work. The points brought out by Mr. Duguid should be perused carefully by mechanical men generally.

HUMANITY OF CORPORATIONS.

It is with pleasure that we note from time to time the recognition of the services of employes, by corporations. From the recent action of the Canadian Manufacturers' Association and the steps being taken by other associations, we can see that the following item

which a daily paper has termed "A Novel Incident," will be more common among Canadian employers.

"The announcement is made that the funds subscribed in aid of the Hull sufferers who were victims of the disastrous explosion last May, will be returned to the donors. The refund is made possible by the action of the explosives company, which settled all claims arising out of the disaster. The situation is unique in Canadian annals, if not in America. Actions speak louder than the most vociferous protestations and the explosives people have certainly demonstrated their position in regard to the unfortunate occurrence in a straightforward and upright as well as practical fashion."

Some time ago a workman was injured at the works of the Hamilton Steel & Iron Co., and this corporation dealt so generously with the employe that Judge Teetzel said he was surprised at the generosity of this company. Recently during the G.T.R. strike, two thousand employes of J. R. Booth, Ottawa, were thrown out of employment for several days, but were paid their wages in full. Whether or not, these corporations were legally responsible, they are to be commended for their liberality and promptness in dealing with their employes.

CREDIT TO WHOM CREDIT IS DUE.

From time to time valuable improvements are made in the output of shops and factories. Often the men at the machine or the men at the bench are the ones responsible for the advancement made in the design and construction of the product. Very seldom, however, is the credit given to those who deserve it. It is therefore gratifying to note in the anniversary number of "Grits and Grinds," a monthly bulletin issued by the Norton Grinding Co., Worcester, the following paragraph from Charles H. Norton:

"In looking back over the ten years just passed, I want to express the appreciation the Norton Co. and Norton Grinding Co., feel for the help the Norton machine and methods have received from foremen and workmen. Such a large measure of loyal help is worthy of comment, and out of it has come many of our best proved theories and best production.

"CUT TIME BETWEEN CUTS."

"To cut costs, cut the time between cuts," is the way E. P. Bullard president of the Bullard Machine Tool Co., Bridgeport, Conn., sums up the problem of reducing shop costs. As an example of the inefficiency resulting from not cutting time between cuts, he pointed out that in a prominent shop, after a difficult piece of work had been finished on a boring mill, it was necessary to wait from 10 a.m. to 3 p.m. before a new forging was available, the machine in the meantime lying idle. He also pointed out that a great deal of time is wasted in boring mill operations in adjusting the machines to the exact size required by the work and stated that considerable time can be saved on machines equipped with micro-

meter dials which permit instant and accurate adjustment.

Mr. Bullard also pointed out the grave importance of the problem of lubrication, stating that from 80 to 90 per cent. of the repairs required on machine tools are made necessary through lack of proper lubrication.

Not only the builders of machine tools, but also employers and employes should consider carefully these questions which are of mutual benefit. A careful study of the problems will no doubt result in advances being made in the care of machine tools and production from same.

SAFETY OF HUMAN LIFE.

Manufacturers are becoming alive to the fact that maximum production is obtained when the shops are kept running at full capacity. This cannot be done when employes are subjected to accidents due to unguarded machinery. With the conservation of human life in view the American Museum of Safety has been opened in New York. A collection has been made of safety appliances ranging from a safety gas cock for kitchen stoves to a miner's helmet for rescue work, and from a portable fire escape to a protection for bursting fly wheels. In addition there are large collections of photographs of protected machines and of workmen using them, and an embryonic library containing selections from the already voluminous literature of the problems. The exhibition has a home for the present in the Engineering Building, No. 29 West Thirty-ninth Street. It is hoped that eventually the museum will develop to such an extent that a commodious structure will be necessary for its own occupancy.

The museum does not confine itself to safety devices for use in the mechanical arts, but rather takes the broader field of "the conservation of human life." With this idea a section has been devoted to problems of sanitation. Dust, ventilation, the lessening of noise, sewage disposal and heating are among the subjects covered. In the particular application to factory accidents the slogan of the museum is "Prevention is a benefaction, compensation an apology."

In the industrial countries of Europe compensation for accidents and enforcement of preventive methods have been very generally subjects for legislation and for governmental interference. In Canada these matters have been left to the individual and are being worked out in that way through the demands of the workmen and their organizations that men at work shall be protected and through the recognition by employers themselves that in the long run prevention of accidents pays.

Opinion has been given by members of the engineering profession that one-half the accidents are preventable. According to them, a conservative estimate of the number of annual accidents which result fatally or in partial or total incapacity for work is 500,000. Reckoning the wage earning capacity of the average workman at \$500 a year—making no allowance for the professional men, railroad presidents, industrialists and other high salaried officials who are injured or killed in the railways, mines,

building trades and other occupations—there is a social and economic loss of \$250,000,000 a year.

Museums of safety have been established in Berlin, Paris, Vienna, Budapest, Milan, Munich, Stockholm, Zurich, Amsterdam and Moscow, all of which are supported by the State, except Vienna.

The one opened in New York cannot help but be of interest to Canadians. The occurrence of accidents has brought out a desire to prevent them and such men as Judge Gary of the United States Steel Corporation, Mr. Crawford, president of the Tennessee Coal, Iron and Ry. Co. and many others are behind the scheme. The officers of the Museum of Safety are: Philip T. Dodge, president; Charles Kirchoff, late editor Iron Age, vice-president; T. Commerford Martin, formerly editor of "Electrical World," Frederick R. Hutton and Dr. N. E. Ditman, chairmen of committees; William J. Moran, counsel, and William H. Tolman, director. One of the planes is the organization of committees of safety in the factories, workshops and other industrial establishments. Laboratories for experimental purposes will also be opened. The object is a worthy one deserving every support.

CANCELLATION OF ORDERS.

The manufacturers of machine tools have been suffering from cancellations of orders at the option of the user. To receive a cancellation for a machine when it is ready to be shipped is a hardship to the builder, that users will no doubt recognize. At the ninth annual convention of the National Machine Tool Builders' Association held recently in New York, the recommendation of C. Walter Wood of the Cincinnati Milling Machine Co., chairman of the committee which investigated this subject, that there be printed on the quotation lists and acceptances of orders, a clause denying the privilege of cancellation for any other reason than the failure of the builder to fulfill his part of the contract, was unanimously adopted. It was pointed out that the cancellation feature had become an abusive custom and had produced a spirit of speculation among the users of machine tools, so that many builders and dealers had reached the point where they would individually take a stand against this practice unless it were done by the association. It is expected that the dealers will follow the manufacturers in this action, and that the effort to stamp out the cancellation abuse will become general.

The purchase of coal on the basis of its heat content is of the same utility as a definite understanding regarding the quality of any other commodity of commerce or industry.

Each new belt should be fully treated with some approved form of belt dressing. The old-fashioned dressing, perhaps the best, also the most costly, is neatsfoot oil, but the rules for applying this substance are the same as for applying modern belt dressing, which is to spread a little of the dressing on the belt and let it soak in. Don't put on much at a time; some people smother a belt with dressing, the belt slips and it usually requires two men to keep the belt on the pulleys until the dressing is absorbed. To avoid this, put on a little dressing at a time and do it often. If the belt is new and you wish to stuff it quickly, apply the dressing liberally at night, just at shutting-down time, and the dressing will be absorbed and the belt ready for service in the morning.—American Machinist.

FOUNDRY PRACTICE AND EQUIPMENT

Practical Articles for Canadian Foundrymen and Pattern Makers, and
News of Foundrymen's and Allied Associations. Contributions Invited.

NEW MONARCH APPLIANCES.

THE Monarch Engineering & Mfg. Co., manufacturers of the "Steele-Harvey" tilting, oil-burning crucible furnace and a large number of other oil burning furnaces and similar appliances, have recently placed on the market some new oil burning appliances that are worthy of the attention of every metal manufacturer. These appliances are herewith illustrated.

Core-Oven Utilizing Waste Heat.

A novel combination of melting furnace and core-oven, in which the waste heat of the furnace is utilized in heating the core-oven, has been constructed. This furnace combination is in Figs. 1 and 2. The furnace shown is the improved Steele-Harvey type and in which metal is melted in crucibles by means of

which the metal can be poured from the furnace, and then into the molds. Some foundrymen use a ladle and others a crucible. For large quantities, the ladle will probably be found cheaper as there is less danger of breakage. The Monarch Engineering & Mfg. Co., of Baltimore,

Md., have constructed a new form of ladle heater for use in drying the ladle or crucible used with a tilting furnace. The heater is shown in Fig. 3. The ladle or crucible is placed under it and the oil flame lighted. A large slab of fire brick over it prevents the escape of heat



Fig. 2.—Rear View of Furnace and Core Oven

oil or gas. Either kind of fuel may be used. In melting, there is always a large amount of heat wasted and it occurred to the company to utilize the waste for heating a core-oven. The result is the combination shown in Figs. 1 and 2. The well known core-oven manufactured by them and which has given so much satisfaction is used with the furnace.

It will readily be appreciated that such a combination means great economy. The cores may be dried without any cost whatever as the waste heat from the melting furnace only is employed for the baking.

Ladle Heater.

In pouring from tilting furnaces, it is necessary to use a ladle or crucible into

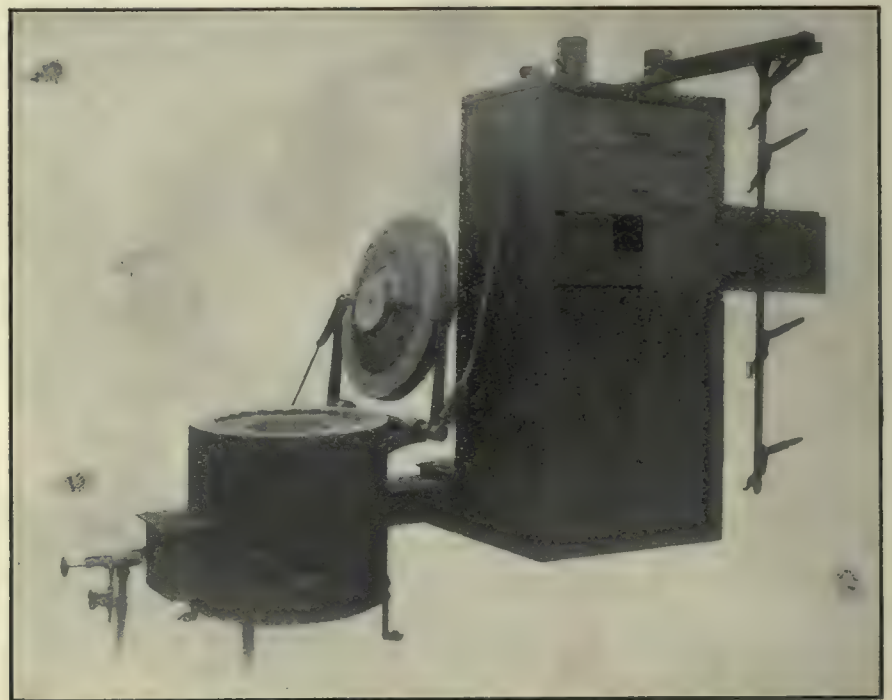

Fig. 1.—Steele Harvey Melting Furnace in Which the Waste Heat is Utilized for Heating a Core Oven.



Fig. 3.—New Form of Ladle Heater Recently Placed on the Market by the Monarch Engineering and Manufacturing Co.

to the burner. The drying takes place rapidly and effectively. A feature of the heater is that the ladle or crucible may be heated to a high temperature and not simply dried as it has been found that much better results may be obtained when it is heated quite hot. The metal from the furnace then does chill when poured into it, and there is little danger from the loss of small or thin castings from cold metal. It has been found that many brass founders



Fig. 4.—Heater Without Ladle.

making small castings, and who have had the idea that a tilting furnace could not be used, have discovered that the fault lay in not having the ladle hot enough when the metal was poured into it. By the use of this ladle heater, however, it is possible to have as hot metal for pouring into the molds as though it were melted in small crucibles direct.

WHEEL COST A SMALL ITEM.

In many grinding operations the wheel wear (the first cost) is a mighty small item of expense when compared with the actual cost of operation, in which we must figure the horsepower consumed, labor, machine investment and the production.

In order to obtain a fair idea of the "cost of wheel," an accurate record was kept of a grinding operation on a 10 x 72-inch Norton plain machine. The work was grinding 35-point carbon open-hearth machinery-steel shafts from the black stock, taking off 1-16 of an inch, reducing from 1½ inch diameter to 1 5-16 inch. A 15 x 2-inch, 24-L alundum wheel was used and in 10 hours' work it showed but 0.270 inch wear. The wheel was trued once at the start and once at the end of six hours. Work speed, 25 feet a minute; wheel speed, 6,100 feet a minute; table reverse, 12 feet a minute. That means a wheel cost of but a very few cents a week.

It is not good policy, therefore, when endeavoring to reach maximum grinding

economy to let the purchase price of a grinding wheel stand in the way of a larger production. Instead of thinking too much about "wheel cost," due consideration should be given to the other factors of cost—labor, which must be figured at from 60 cents to \$1 an hour; the horsepower consumed in grinding; the production necessary to make the grinding-machine investment a profitable one and the many advantages of rapid production. These are the factors that must be weighed carefully when purchasing grinding wheels. Compare them with the "wheel cost."

Economy consists in getting the right wheel for the work and operating it under the most favorable conditions, and the original cost of the wheel in most cases is too small an item to take into consideration.—Grits and Grinds.

NEW ANTI-FRICTION ALLOY.

A new alloy for use as an anti-friction metal has been patented by Joseph R. Stratton of Moncton, New Brunswick. He claims that a zinc base alloy has several advantages in it and particularly as the melting point is sufficiently high to prevent the running out when a bearing containing it heats. He recommends the following proportions:

Zinc	25 lbs.
Lead	3 lbs.
Tin	1½ lbs.
Copper	½ lb.
Antimony	3 oz.

When calculated in percentages, the mixture works out as follows:

Zinc	82.0 p.c.
Lead	9.8 p.c.
Tin	5.8 p.c.
Copper	1.7 p.c.
Antimony	0.7 p.c.

The alloy is recommended by the inventor for railroad and similar heavy work.

John O'Brien has resigned as night superintendent of the Mahoning Valley Works of the Republic Iron & Steel Co. at Youngstown, Ohio, to become superintendent of the Manitoba Rolling Mills, Winnipeg.

Frank Forsyth recently resigned the position of mechanical superintendent at the works of the Lundy Shovel & Tool Co., Peterborough. He is succeeded by Peter H. F. Spies, late mechanical engineer with Siemens, London, England. Mr. Spies will be assisted by W. Jones, late foreman shovel maker with Henry Mills, Victoria Shovel Works, Worcester, England.

H. J. McCaslin, who is a frequent contributor to Canadian Machinery, has resigned his position with the Wellman, Seaver, Morgan Co., where he was head of the pattern department for ten years,

to become instructor in pattern making at the Cleveland Technical High School. The employes of the above company presented him with a watch and fob when leaving.

N.T.R. SHOP EQUIPMENT.

The firms successfully tendering for the equipment of the N.T.R. Shops at Transeona, near Winnipeg, are as follows:—

Machine Tools.

In addition to the Bertram tools, the Canadian Fairbanks Co., Montreal, secured the following orders:

One 24 inch Norton grinder; one 14 inch McDougall bolt lathe with taper attachment; three 16 in. by 6 ft. McDougall engine lathe with taper attachment; one 18 in. Gardner disc grinder; One 14 in. McDougall lathe with taper attachment; two 18 in. by 8 ft. McDougall standard engine lathe with taper attachment; one 22 in. by 10 ft. McDougall lathe with taper attachment; two "Royal" 4 in. power hack saws; one Whitton revolving centering machine, capacity ¼ in. to 4 in.; one 14 in. by 5 ft. McDougall bolt lathe with taper attachment; One Morse drill grinder No. 2; one 2 in. Acme single head bolt cutter; one 2 in. Acme triple head bolt cutter; one Bridgeport guide bar grinder; one McDougall 18 in. by 6 ft. engine lathe; one 16 in. Dresses Monitor lathe with taper attachment; one Warner & Swasey grinder; one No. 3 Blount grinder; three Norton double emery grinders with wheels 14 in. by 2½ in.; one 3 in. flue expander; one McGrath flue welder and swedger; fourteen 14 lb. sledges; one Fairbanks' 200 lb. strap hammer with crane; one Fairbanks' 125 lb. strap hammer with crane; One McDougall 14 in. by 5 ft. bolt lathe; two 400 lb. anvils; two 14 lb. cross pein blacksmiths' sledge hammers; one set of Blacksmiths' miscellaneous tools; two Mummert, Wolfe & Dixon combined grind stones and oil stones; fifteen 5 in. self-adjusting bench vises; fifteen 6 in. self-adjusting bench vises, all sivel type; sixty 6 in. box vises; eighteen Fairbanks' railway trucks; twenty-five Tommy bars; ten chisel bars; eighteen 10 lb. cross pein sledges; eight 14 lb. cross pein sledges; twenty-eight sets of box vises; twenty-five ratchet drills; two surface blocks, 6 by 9 ft.; four oil burners.

The Holden Co., 354 St. James St., Montreal received orders for the following:—

17 pneumatic drills, "Little Giant" size 'OR' medium, reversible, for all ordinary drilling and reaming; 5 heavy pneumatic drills, size 'ER' reversible, for heavy reaming and tapping; 15 medium pneumatic chipping hammers, No. 2, new Boyer, hexagon tool nose; 6 heavy pneumatic chipping hammers No. 1, new Boyer, hexagon tool nose; for very heavy chipping and light rivetting; 3 heavy pneumatic riveters, new Boyer,

No. 80, 8 in. stroke; 12 "Little Giant" flue expanders, assorted sizes; 3 new Boyer long holders-on; 1 12 in. Chicago compression rivetter. All complete with necessary hose, chisel blanks, rivet sets, twist drills, etc. These tools are all of Chicago Pneumatic Tool Company's manufacture.

The Morton Manufacturing Co., Muskegon Heights, Mich., will supply the following machines:

1 60 in. stroke Morton draw-cut cylinder planer with full equipment; 1 32 in. special railroad shaper for planing locomotive axle boxes, with full equipment; 1 30 in. and 2 26 in. stroke draw-cut shapers, with attachments for railroad shops.

All of the above machines to be motor driven.

Joseph T. Ryerson & Son, Chicago, will supply the following:

1 Gisholt tool grinder; 1 12 ft. Ryerson flanging clamp; 1 Ryerson universal cold saw; 1 pipe-machine; 1 Ryerson combined hot saw and expander; 1 Ryerson automatic safe end cutting-off machine; 1 Ryerson motor driven flue-cleaning machine; 1 Lennox rotary bevel shear; 1 Lennox rotary splitting shear; 2 high speed cutting-off saws; 1 600 ton hydraulic wheel press; 1 200-ton hydraulic wheel press; 2 3 in. by 8 ft. hydraulic pumps, high pressure; 1 60 in. throat, hydraulic punch; 1 560 ton, 4-column hydraulic forging press; 1 12 in. by 15 in. accumulator; 1 18 in. by 6 in. gap rivetter; 1 130 ton hydraulic bulldozer; 1 170 ton hydraulic shear; 1 hydraulic bar shear; 1 60 ton hydraulic squeezer; 1 hydraulic spring bander; 1 deep throated punch, capacity 3 in. hole in 2 in. plate; 1 Hydraulic band remover; 4 Ryerson steam hammers, also miscellaneous equipment of smaller machines.

Other successful tenders for machine tools were:—John Bertram & Sons Co., W. H. Foster Co., A. B. Jardine, London Machine Tool Co., Mussen's, Rudel-Yeates Machinery Co., A. R. Williams Machinery Co., Williams & Wilson.

Canadian Westinghouse will supply motors for motor drive.

Laurie & Lamb will supply three Belliss & Morecom two stage, two crank air compressors, capable of taking in 660 cu. ft. of free air per minute and delivering same at a final pressure of 80 to 120 lbs. per sq. in. The compressors will be direct connected to Lancashire Dynamo & Motor Co.'s motors, 150 h.p. 550 volts, 60 cycles, 3 phase. These compressors are of the Belliss vertical high speed type such as have been supplied to most of the principal mines in South Africa and other parts of the world.

Francis Hyde & Co., Montreal, are furnishing the following equipment:—

Grey Iron Foundry Equipment.

1 Blast pipe and gates for cupolas; 1 No. 11 Sturtevant blower; 1 40 h.p. A. C. Motor for above blower, blower platform; 1 pneumatic elevator; 1 5 h.p.

A. C. Motor; 2 Motor driven emery grinders; 1 25 h.p. A. C. motor; 2 chipper's benches, 3x12 ft.; 1 core oven 12x12 ft. by 9 ft.; 2 core ovens, 7 ft. by 12 ft. by 9 ft.; 1 portable core oven; 6 water tanks, 18 in. by 18 in. by 36 in.; 8 molding tubs; 12 molders tools for bench work; 6 molders tools for floor work, all complete as specified; 50 molder's shovels; 50 riddles, 1/2 in. mesh; 50 riddles, 1/4 in. mesh; 25 gal. iron water buckets; 25 rammers; 50 soft brushes.

Brass Foundry Equipment.

3 brass furnaces, 26 in. inside diameter, complete with linings, etc; brass furnaces, 32 in. inside diameter, complete with linings, etc; 1 steel stack, complete; floor grates, complete as specified; 1 pair crucible tongs for No. 35 crucible; 1 pair crucible tongs for No. 50 crucible; 1 pair crucible tongs for No. 60 crucible; 1 pair crucible tongs for No. 80 crucible; 1 pair crucible tongs for No. 100 crucible; 1 pair crucible tongs for No. 150 crucible; 1 shank for No. 35 crucible; 1 shank for No. 50 crucible; 1 shank for No. 60 crucible; 1 shank for No. 80 crucible; 1 shank for No. 100 crucible; 1 shank for No. 150 crucible; 1 portable core oven, complete; 1 core maker's bench, 3 ft. wide, 12 ft. long; 1 chipper's bench, 3 ft. wide, 12 ft. long; 1 band saw, complete; 1 sprue cutter, complete; 1 10 h.p. A. C. motor, complete; 1 grinder, complete; 4 molding tubs, complete; 1 moulding machine, complete; cold rolled steel shafting, 2 15-16 diameter; safety flanged couplings for 2 15-16 in. shaft; 24 in. drop hangers, complete self-oiling type; erecting and lining up main line pulleys; structural steel frame work, motor brackets, etc., including painting, erecting, complete.

Furnaces and Forges.

1 single McCaslin forge; 1 open type forge; 1 furnace for boiler flanging work; 1 annealing furnace, 8 ft. by 12 ft.—6 ft. inside; 1 tire furnace for tires up to 96 in. diameter; 2 coke forges; 2 coppersmith's forges; 1 flange forge; 13 double McCaslin forges, 48 in. by 48 in. hearth; 1 single McCaslin forge, for spring work; 1 single open frame forge for frame work; 1 bolt furnace, 9 in. by 37 1/2 in. for bolt forging machine; 1 forging machine furnace, 20 in. by 40 in. for 3 1/2 in. forging machine; 1 bulldozer furnace, 3 ft. by 9 ft., for arch bars, etc.; 1 axle furnace, 4 ft. 11 in. by 7 ft. 11 in., for axles, etc.; 1 furnace, 2 ft. 10 in. by 4 ft. 4 in., for 3,500 lb. hammer; 1 furnace, 2 ft. by 5 ft., for spring tapering rolls; 1 double furnace, 5 ft. 6 in. by 8 ft., for spring setting and case hardening; 1 furnace, 2 ft. by 5 ft., for nibber and trimmer; 1 furnace, 2 ft. by 7 ft., for spring setting; 1 furnace, 4 ft. by 4 ft., for spring band work; 1 porter bar furnace, 2 ft. by 4 ft., for bar work; 1 double McCaslin forge, 48 in. by 48 in. hearths; 1 bulldozer furnace, 2 ft. by 6 ft.

Foundry equipment is also being supplied by Whiting Foundry Equipment Co., Harvey, Ill.

Cranes.

The order placed with Geo. Anderson & Co., Montreal, is as follows:—

1 5-ton electric travelling crane, 57 ft. 2 in. span, for grey iron foundry; 1 10-ton hand power travelling crane, 57 ft., 1.5 in. span, for power house; One 5-ton hand power overhead travelling crane, 35 ft., 2 in. span, for stores platform; 3 1-ton hand power travelling cranes, 26 ft., 10.5 in. span, for grey iron foundry; 4 electric underbraced swing cranes, for grey iron foundry and yard; 11 pillar swing cranes for the forge shop.

Others supplying cranes are Morgan Engineering Co., and Mussen's.

The Manitoba Bridge & Iron Works, Winnipeg secured orders for shafting, hangers and structural steel framework.

The belting order was placed with D. K. McLaren. The industrial tracks and turntables will be supplied by the Whiting Foundry Equipment Co.

Lockers were shipped in November by the Dennis Wire & Iron Works Co., London. They are double tier style, 12 by 12 by 42. They are made entirely of cold rolled flat patent leveled steel sheets. The doors are expanded metal with angle steel frames with steel reinforcing platform for top and bottom.

Power House.

John Inglis Co. supplied Erie City water-tube boilers, air compressors and pumps. John McDougall Caledonia Iron Works supplied pumps.

The C. G. E., Toronto, supplied 3 engine type, 3-phase-500 K.W.-600 volt generators, 150 r.p.m.; 1 engine type, 3-phase-250 K.W.-600 volt generators, 150 r.p.m.; 1 engine type D.C. generator, 150 K.W., 250 volts, 225 r.p.m.; 2 D. C. exciters, 125 volts, 275 r.p.m.; 1 Motor generator set, 225 H.P. capacity.

The Robb Engineering Co., Amherst, N.S., were awarded contract for one 3,000 h.p. Hoppes feed water heater.

The following engines are being built by the Goldie & McCullough Co., Galt: Three 21-in. and 34-in. by 30-in. 750 I.H. P. cross-compound, heavy duty non-condensing corliss engines, each direct connected to one 500 K.W., three phase, 60 cycle generator, speed 150 R.P.M.; one 18 in. by 30 in. 375 I.H.P. heavy duty, simple non-condensing corliss engine, direct connected to one 250 K.W., three phase, 60 cycle generator, speed 150 R.P.M.; one 14 in. by 30 in. 225 I.H.P. heavy duty simple non-condensing corliss engine, direct connected to one 150 K.W. direct current generator, speed 150 R.P.M.; two 11 in. by 12 in. (exciter) side crank, non-condensing ideal engines, direct connected to 75 K.W., D.C. generators, speed 275 R.P.M., 115 H.P. each.

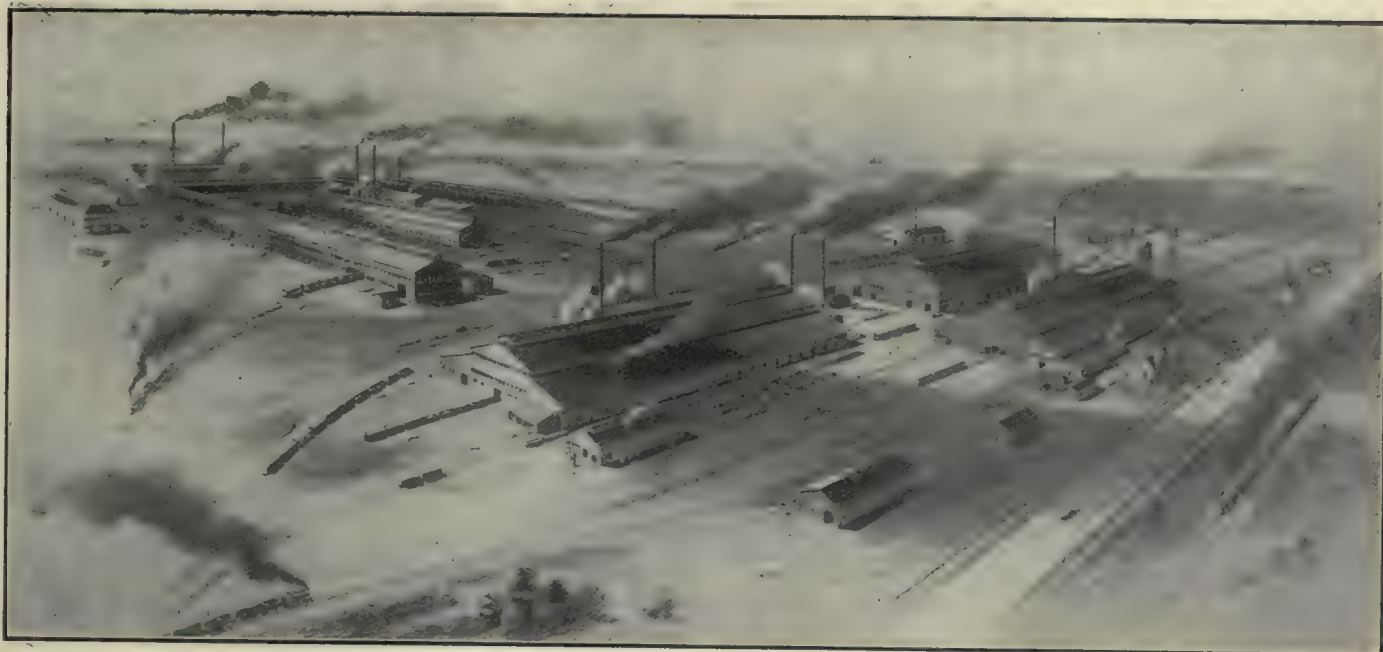

View of the Plants of the Ontario Iron and Steel Co., and the Page-Hersey Iron Tube and Lead Co., Welland.

The Large Steel Foundry and Pipe Mill at Welland

Under One Management, There are Two Large Industries at Welland—the Ontario Iron & Steel Co., and the Page-Hersey Iron Tube & Lead Co.—Both Large Concerns Producing Iron and Steel Products. The Steel Plant has Been in Operation for Some Time, While the Pipe Mill was Opened Quite Recently. Both These Plants are so Well Equipped and Modern in Every Particular That a Brief Description is Interesting and Instructive.

THE steel plant of the Ontario Iron and Steel Co., Welland, has the largest, most extensive, and probably the best equipped steel foundry in Canada, producing a very large output each year. The plant is capable of handling almost any size of work, and have successfully made intricate castings weighing upwards of 27,000 pounds—such articles as generator frames, turbine runners, etc.

The steel foundry is housed in the large building to the right in the half-tone, and is conveniently arranged throughout. It is 250 ft. long by 180 ft. wide. The small building in the immediate foreground is the pattern storage building, a building 100 ft. long by 50 ft. wide, but which is much too small to accommodate conveniently all the patterns they have accumulated. Additions are therefore contemplated. The smaller building to the right which is 100 ft. by 34 ft., is the pattern shop, where the majority of the patterns are made. The equipment is of the best to produce high class work.

Back of the steel foundry, is the open-hearth ingot shop, where open-hearth steel ingots are produced. The building is of the usual light corrugated galvanized construction, so generally used for such work, and measures 200 ft. by 100 ft. The furnaces are ranged along the back wall, with the ingot pit directly before it, and the stripping floor in front of that again. Convenience has been the keynote of the whole construc-

tion, which has been carried on throughout the whole plant by A. M. Moseley, works manager, who installed the whole plant of both concerns.

To the left of the ingot shop is the rolling-mill, a building 300 ft. long by 100 ft. wide, in which are two sets of rolls, actuated by a large induction motor. A large variety of bar stock and re-inforcing bars are made, as well as angles up to 2 inches in size.

In front of this building is the rail joint mill, a 100 by 40 ft. building devoted to the production of this particular class of work.

Pipe Works.

The series of buildings back of these buildings just described, belong to the Page-Hersey Iron Tube and Lead Co., which, as before mentioned are under the same management as the Ontario Iron and Steel Co. The building in the far distance is one that the prophetic eye of the artist portrayed, as are also the two smaller buildings to the left in the illustration. They are additions that are to be erected in the very near future, for the capacity of the pipe mill is already taxed.

At the end of the long shop, extending to the right, is the pipe rolling mill, where the rough skelp passes through the various operations that finally turn out as pipe. It is a building 180 ft. long and 100 ft. wide.

The long building before-mentioned, contains pipe threading department, and

the pipe storage. The nearer third of the building is not completed as yet, as the company is still quite young. It is a building 50 ft. wide, with the finishing section 140 ft. long, and the storage of a similar length.

On the right, projecting this way from the rolling mill, is the coupling department and machine shop, the building being 180 ft. long by 50 ft. wide. An extensive machine shop is necessary to repair the many breaks occurring in such heavy machinery subjected to considerable strains.

To the right of this building may be seen a long crane way, 300 ft. long, running into the far end of the rolling mill. It extends over the whole length of the skelp storage yard, and is used for carrying the latter into the rolling mill.

At the far end of the rolling mill is another lightly constructed building where the producers are located. While national gas is plentiful, producer gas has been found to be superior. Three large producers are in service.

Transportation facilities are excellent. In the immediate foreground, is to be seen the main line of the Canada Southern division of the Michigan Central. Numerous switches and tracks reach every part of the yard. The same set of tracks lead to a small industrial line running to the Welland Canal, seen in the distance. In every way, the plant is thus ideally located.

INDUSTRIAL ^A_N^D CONSTRUCTION NEWS

Establishment or Enlargement of Factories, Mills, Power Plants, Etc.; Construction of Railways, Bridges, Etc.; Municipal Undertakings; Mining News.

Foundry and Machine Shop.

SYDNEY—An agreement between the Dominion Steel Co. and Alexander Cross & Sons will result in the latter erecting grinding machinery to deal with the Steel Co.'s production of basic slag. This means a large expenditure in buildings and machinery and the employment of a considerable staff of men.

HUMBERSTONE—The foundry and automobile supply store of T. E. Reeb & Sons, here, was destroyed by fire on Nov. 23. The loss is \$15,000 and insurance \$4,000.

CHELMSFORD—Anthracite coal of the best quality has been found here and experts say that the whole valley in which the town is situated is underlaid with coal. A company has been formed and the coal will be marketed in a short time.

HUNTSVILLE, ONT.—The Huntsville Engine Works Co. has assigned.

CALGARY—The Ottawa Furnace Co. will erect a plant here for the manufacture of furnaces, ranges, etc.

SOUTHAMPTON, N.S.—The carriage factory of S. Fillmore, was destroyed by fire. Loss, \$35,000.

EDMONTON—Edmonton will spend \$500,000 for new waterworks and pumping machinery.

BOSTON MILLS, ONT.—The flour mills of H. Braeken & Son, were destroyed by fire. Loss, \$15,000.

SELLWOOD, ONT.—The Moose Mountain Mining Co. have decided to erect a new refining plant on their property here. With this new addition it is estimated that a total of 2,500 tons of finish iron will be turned out daily. Mackenzie & Mann are prominent in the management of the company.

PORT ARTHUR, ONT.—A large foundry will be erected at Port Arthur to manufacture cast-iron pipes and car wheels. This is in conjunction with the Atikokan blast furnace. Five hundred thousand dollars will be expended in the project and as this will make a very much larger demand for the pig iron of the present plant, which is of 200 tons capacity and 100 coke ovens, the extension of the blast furnace is already under serious consideration.

SUALT STE MARIE—On Nov. 12 the blast furnaces of the Lake Superior Corporation turned out 680 tons of Bessemer iron. The former record for one day was 576 tons. The average output for the last month was 652 tons per day.

PORT HOPE—The Judicial Committee of the Privy Council in England, which is the court of last resort in the British Empire, has decided in favor of the Standard Ideal Co., Port Hope, Ont., in the litigation between that company and the Standard Sanitary Mfg. Co., Pittsburgh, Pa. The matter at issue was the use of the word "Standard" in the Port Hope company's name. In the Canadian courts the case was decided in favor of the Pittsburgh company. The Standard Ideal Co. will now, it is said, increase its manufacturing capacity. It has already under construction at plant No. 2 a building that is to cost about \$100,000.

PORT ARTHUR—It is announced that the Atikokan Iron Co.'s furnace here will be kept in operation all winter.

OTTAWA—The Schwab Boiler Heating Co. has been incorporated under Dominion laws, with a capital of \$100,000, the head office to be at Ottawa.

NEEPAWA, Man.—The Match Factory Co., whose building operations here have begun is to put in a large amount of machinery.

ORILLIA—Proposals have been made to the National Hardware Co., to remove its lock works from that town, but the company has practically decided to enlarge the Orillia plant rather than build entirely new works elsewhere.

FORT WILLIAM—Lumby-Stenhouse, Ltd., is building a foundry and machine shop here to cost \$40,000.

PORT DOVER, ONT.—The Widespread Implementation Co. is putting up buildings. Its planing mills are nearly ready for the machinery, and the foundry building is progressing rapidly.

FORT WILLIAM—The Superior Rolling Mills Co., of Fort William, recently organized to establish a plant at that city, has been merged with the Steel Co., of Canada. J. Orr Callaghan, of the Steel Co., states that plans are in preparation for the plant on a considerably larger scale than that contemplated by the Superior Rolling Mills Co.

WINDSOR—The Winkley Co. will establish a Canadian branch at Windsor, for the manufacture of brass goods, at a cost of about \$15,000.

YORKTON, SASK.—The Birrell Motor Plow Co., of Winnipeg, may establish a branch factory here at a cost of \$50,000.

HAMILTON—The Canadian Steel Co. obtained a permit on Oct. 21 for the first of its new buildings to be erected here. The structure will be a 1-storey frame and corrugated iron mill building 210 x 70 feet.

TORONTO—Fire damaged the plant of the Wilkinson Plow Works to the extent of several thousand dollars on Nov. 8. The molding shop was destroyed together with scores of patterns.

MEDICINE HAT—A by-law was carried on Oct. 17th granting a site and a \$10,000 gas well to the Alberta Iron Roller Mills Co. Work on the buildings has commenced.

FERGUS, ONT.—Fergus may grant Beatty Bros., manufacturers of agricultural implements, a loan of \$25,000 for 15 years, without interest, and a fixed assessment of \$5,000, exclusive of school taxes.

MONCTON—A proposition is on foot to move the Whelpley Skate concern from Greenwich, King's County, to Moncton, N.B. The council of Moncton has fixed the taxes on the industry at \$1.00 a year for ten years, and promises free water. Moncton men are subscribing stock.

TORONTO—H. Disston & Sons are to erect a one storey addition to their Canadian saw-making plant on Fraser Avenue, to cost \$6,000.

SARNIA—The Sutherland Fence Co., of this place, are building a new factory, 150 by 100 ft., capable of handling a large output of woven wire fence.

AMHERST, N.S.—The Amherst Malleable Co. is extending its premises by an addition in which it is expected 150 men will be employed.

ST. BONIFACE, MAN.—The Winnipeg Ceiling and Roofing Co. is building a \$60,000 plant at St. Boniface.

GANANOQUE—Fire was the cause of from \$150,000 to \$175,000 loss to the Ontario Wheel Co.'s works here on Nov. 3rd. Insurance will be rebuilt as Gananoque has guaranteed the company exemption from taxation for ten years.

MORRISBURG—The tack factory will increase the number of machines used from twenty-five to fifty. A steam heating plant is being installed.

GUELPH—The property of the Grundy Stove Co. has been purchased by James Fowler, of Toronto, who will commence operations shortly.

TORONTO—The Canadian Autopress Co. have purchased a factory at the corner of Eastern and Carlaw Avenues, this city, and will build an addition.

GUELPH—A proposition has been accepted by this city from Mr. Phillips, of Detroit, re the establishing of a plant for the manufacture of automobiles. The company will occupy the old Morlock factory for three years at a nominal rental of \$1 and for the remaining seven years of a ten year lease at \$600 per year.

WINNIPEG—The Winnipeg Wire and Iron Works have registered a partnership between Chas. E. Hammersley and Geo. A. Pepper.

TORONTO—The King Radiator Co. is making extensive additions to its plant.

WALKERVILLE—The Penherthy Injector Co. is extending its plant.

OTTAWA—Negotiations are being carried on with Detroit capitalists regarding the establishment of an automobile factory here.

TORONTO—The Ontario Wind Engine & Pump Co. is building a new \$6,000 boiler house. The company reports having received large orders for railroad tanks.

TORONTO—The Dayton Scale Co., of Dayton, Ohio, will establish a branch factory in Toronto. A site with 200 feet frontage on Campbell Ave. has been purchased.

VANCOUVER—An engineering works to cost \$5,000,000 is to be established near this city. The proposition is being looked after by Lincoln Chandler, of Birmingham, England, who is connected with the British Empire Bridge Works in that city, and is secretary of the Metropolitan Amalgamated Railway Carriage and Wagon Co., of Saltley.

TORONTO—Permits were issued during the week of Oct. 22-31 for the erection of a 3-storey brick automobile factory for the Elder Carriage Works to cost \$12,000; a 4-storey brick warehouse for the Consolidated Optical Co. at \$45,000; a 3-storey brick factory for the National Electric Heating Co. at \$14,000; a brick car storage for the Toronto Ry. Co., at \$14,500.

KAMLOOPS, B.C.—A smelter, of the reverberatory type, is to be established here by the interests operating the Iron Mask properties.

KINGSTON—The locomotive works here have received an order from the C.P.R. for eight additional engines, making 18 now under contract.

YARMOUTH, N.S.—The Burrell-Johnson Iron Co. are fitting four steamers with boilers and machinery.

WOODSTOCK—The Maximilian Machine Co., of Buffalo, will erect a Canadian branch factory here for the manufacture of pneumatic rivetting machines. \$100,000 will be expended.

GALT—A second storey is being added to the plant of the Galt Motor Co. The addition will be of brick and used for the manufacture of two cycle engines.

LACHINE, QUE.—The Canadian Tube & Iron Co., of Ottawa, are contemplating the erection of a large plant here.

SARNIA—An offer has been received from a party in Houston, Texas, to start a gas engine factory. The offer is conditional upon a free site and exemption from taxation.

MONTREAL—It is officially announced that the amount to be expended by the Canadian Pacific Railway on improvements in connection with the Place Viger new passenger and freight terminals and freight shed is \$3,000,000.

PORT ARTHUR—The steamship Beaverton brought a cargo of machinery to Port Arthur a few days ago for the Western Dry Dock & Shipbuilding Co.'s plant.

ST. BONIFACE, MAN.—The Rice Malting Co. will buy engines and elevators for its new \$250,000 brewery.

117278

Author Vol. 6, 1910

Author

Title Canadian Machinery

Title

UNIVERSITY OF TORONTO
LIBRARY

Do not
remove
the card
from this
Pocket.

Acme Library Card Pocket
Under Pat. "Ref. Index File."
Made by LIBRARY BUREAU

